



American Gourmet Smoker, BBQ and Grill

Product Guide Model 10201595

Tools needed for assembly:

- Phillips Screwdriver
- Flat Head Screwdriver
- Two adjustable wrenches
- Hammer

IMPORTANT: Fill out the product record information below.

Serial Number _____
Date Purchased _____

Estimated Assembly Time: 1 Hour



FOR OUTDOOR USE ONLY

⚠ CAUTION:

Read and follow all safety statements, assembly instructions, and use and care directions before attempting to assemble and cook.

INSTALLER/ASSEMBLER:

Leave this manual with consumer.

CONSUMER:

Keep this manual for future reference.

⚠ WARNING:

CARBON MONOXIDE HAZARD

Burning charcoal inside can kill you. It gives off carbon monoxide, which has no odor. NEVER burn charcoal inside homes, vehicles, or tents.

The following are trademarks registered by W.C. Bradley Co. in the U.S. Patent and Trademark Office: Caldera®; Charcoal2Go®; Char-Broil®; America's Legendary Barbeque Company®; American Gourmet®; Bandera®; Brush Hawg®; CB 940®; Char-Diamonds®; Char-Broil Charcoal/Gas®; Everybody Grills®; Everybody Outside®; FastStart®; Grill 2 Go®; Grill 2 Go® Express®; Grill Lovers®; Infrared Grilling That's All About U®; Keepers of the Flame®; New Braunfels Smoker Company®; Patio Bistro®; Patio Caddie®; Patio Kitchen®; Pro-Sear®; RED®; Quantum®; Santa Fe®; Sear and Grill®; Sierra®; Signature Series®; Sure2Burn®; The Big Easy®; Trentino®; U®; Wild West Tradition®; and the following marks:



AUTO-CLEAN™

The following are trademarks of W.C. Bradley Co.: Advantage Series™; Auto-Clean™; Chef Tested™; Commercial Series™; Designer Series™; Diamond Flame™; Double Chef™; Fireball™; Firenzy™; FlavorMaster™; Front Avenue™; Grill 2 Go® Advantage™; Hog and Yard Bird™; H2O Smoker™; Infrared. Grilling's Juicy Little Secret™; Incredible Taste. Infallible Results™; Infrared Inside™; Insure™; Let's Grill Something Together™; Lev-Alert™; Longhorn™; Magneto™; Precision Flame™; Quick2Burn™; QuickSet™; Ready When You Are™; Season, Set, And Savor™; Sizzle On The Grill™; Signature Series™; SureFire™; The Minute Grill™; Torchfork™; Universal Grill Parts™; You Bring the Party™ TFC™ is a trademark of Tec Infrared Grills.

Protected under one or more of the following U.S. Patents: 5,421,319; 5,458,309; 5,579,755; 5,996,573; 6,135,104; 6,279,566; 6,331,108; 6,484,900; 6,526,876; 6,595,197; 6,640,799; 6,640,803; 6,729,873; 6,739,473; 6,749,424; 6,792,935; 6,951,213; 7,047,590; 7,516,693; D364,535; D372,637; D373,701; D377,735; D383,035; D397,910; D405,643; D406,005; D406,009; D413,043; D413,229; D414,982; D415,388; D416,164; D416,441; D417,587; D417,588; D422,516; D423,274; D423,876; D428,303; D430,772; D435,396; D436,004; D438,059; D438,060; D438,427; D439,110; D442,505; D443,179; D443,354; D443,464; D447,384; D447,385; D447,909; D448,610; D448,614; D448,615; D448,616; D448,975; D449,492; D450,544; D451,759; D454,028; D454,031; D455,205; D455,206; D456,202; D456,222; D456,223; D457,789; D458,520; D458,760; D458,802; D459,088; D459,148; D459,149; D459,161; D459,163; D459,586; D459,943; D460,312; D460,313; D460,318; D461,359; D465,123; D465,693; D466,307; D466,439; D466,752; D473,414; D474,371; D477,498; D477,501; D477,504; D477,506; D477,746; D478,471; D478,472; D480,914; D491,410; D494,009; D494,413; D498,523; D500,359; D504,048; D530,098; D535,000; Canada: D97,504; D99,355; D102,037; D104,200; D108,377; 2,315,567; France: D010,231; D010,422; D010,590; D010,849; 1,089,646; South Korea: 384,565; United Kingdom: 2,099,402. Other Patents Pending. © 2009 W.C. Bradley Company

If you have questions or need assistance during assembly, please call 1-800-241-7548. To insure your satisfaction and for follow-up service, register your appliance online at www.charbroil.com/register

TABLE OF CONTENTS

Product Record Information	1
Safety Symbols	2
Preparing to use your Grill	3
Smoker Maintenance	3
Cooking Tips	4-5
Limited Warranty	6
Parts List/ Parts Diagram	7
Assembly	8-13
Hardware List	14
Registration Card	16

This instruction manual contains important information necessary for the proper assembly and safe use of the appliance.

Follow all warnings and instructions when using the appliance.

Safety Symbols

The symbols and boxes shown below explain what each heading means. Read and follow all of the messages found throughout the manual.



DANGER

DANGER: Indicates an imminently hazardous situation which, if not avoided, will result in death or serious injury.



WARNING

WARNING: Indicates an potentially hazardous situation which, if not avoided, could result in death or serious injury.



CAUTION

CAUTION: Indicates a potentially hazardous situation or unsafe practice which, if not avoided, may result in minor or moderate injury.



WARNING

FAILURE TO READ AND FOLLOW INSTRUCTIONS FOR LIGHTING CHARCOAL MAY RESULT IN SERIOUS PERSONAL INJURY AND OR PROPERTY DAMAGE.



WARNING

- Most surfaces on this unit are hot when in use. Use extreme caution. Keep others away from unit. Always wear protective clothing to prevent injury.
- Keep children and pets away.
- Do not move this unit during operation.
- Never substitute gasoline, kerosene or alcohol for charcoal starter. In some states, the use of charcoal starter is prohibited by law. In this case, paraffin-based starter cubes can be substituted for charcoal starter. Never use charcoal starter fluid with an electric starter.



WARNING

CALIFORNIA PROPOSITION 65

1. Combustible by-products produced when using this product contains chemicals known to the State of California to cause cancer, birth defects, or other reproductive harm.
2. This product contains chemicals, including lead and lead compounds, known to the State of California to cause cancer, birth defects or other reproductive harm.

Wash your hands after handling this product.



WARNING

All surfaces can be hot during use. Use protection as required to prevent burning.

Do not use this unit on or near combustible surfaces or structures such as wood decks, dry leaves or grass, vinyl or wood siding, etc.

SEE OWNERS MANUAL FOR IMPORTANT SAFETY INFORMATION.



CAUTION

For residential use only. Do not use for commercial cooking.

Preparing and Using Your American Gourmet Smoker

Before cooking with your American Gourmet Smoker, the following steps should be closely followed to both cure the finish and season the interior steel. Failure to properly follow these steps may damage the finish and/or impart metallic flavors to your first foods.

1. Brush all interior surfaces including grills and grates with vegetable cooking oil.
2. Build a small fire on the fire grate, being sure not to lay coals against the walls.
3. Close door. (Position butterfly damper and smokestack damper approximately at one quarter open.) This burn should be sustained for at least two hours, the longer the better. Then, begin increasing temperature by opening the butterfly damper and smokestack damper half-way and adding more charcoal. Your American Gourmet Smoker is now ready for use.

Rust can appear on the inside of your smoker. Maintaining a light coat of vegetable oil on interior surfaces will aid in the protection of your unit. Exterior surfaces of smoker may need occasional touch up. We recommend the use of a commercially available black high temperature spray paint. NEVER PAINT THE INTERIOR OF THE UNIT !

GRILLING

Wood is recommended, however charcoal or a combination of both may be used as the fuel source for grilling, with the fuel source placed and ignited on the fire grate. Do not build too large of a fire. We recommend starting a fire with no more than 2 pounds of charcoal (approximately 20 briquettes). After allowing the fire to burn down, place the cooking grates in the smoker. Failure to read and follow instructions for lighting charcoal may result in serious personal injury and/or property damage.

SMOKING AND SLOW COOKING

If using the American Gourmet Smoker as a smoker or slow cooker, remove the cooking grill from the firebox and build your fire on top of the fire grate in the firebox. Either charcoal or wood may be used, but wood is the recommended fuel for its rate of burn and the flavor it imparts to the food being cooked. Most seasoned hardwoods are good for smoking such as hickory, mesquite, pecan, oak, and many other fruit woods. The firebox will accommodate most split fireplace size logs (16"). Bark should be avoided or burned off first as it contains a high acid content and imparts an acrid flavor.

After allowing the fire to burn down, close the doors and control the temperature and smoke with the dampers located on the firebox and atop the smokestack. Smoke is contained within the chambers, which will reduce burn while imparting more smoke flavor. Do not operate the Smoker with temperatures exceeding 450 degrees in the smoker chamber. Place the food in the smoker chamber and monitor the temperature. Cooking and smoking are taking place using indirect heat. There is no need to worry about a grease fire flare-up ruining the food. Do not place food within 6" of the opening from the firebox into the smoker chamber. A general rule of thumb for cooking is about 1 hour per pound for smoking large cuts of meat. Refer to a cook book for specific cuts of meats. Limit the number of times you open the smoker chamber door as this will allow heat to escape and extend the cooking time.

Grilling with Wood Chips/Wood Chunks

For a more robust smoke flavor while using charcoal briquettes or lump charcoal, try adding wood chips or several wood chunks to the fire. Wood chunks are available in a variety of natural flavors, and can be used alone or in addition to charcoal. As a general rule, any hardwood that bears a fruit or nut is suitable for cooking. However, different woods have very different tastes. Experiment with different woods to determine your personal favorite, and always use well-seasoned wood. Green or fresh-cut wood can turn food black, and tastes bitter.

Our Recommendations:

Chicken - Alder, Apple, Hickory, Mesquite, Sassafras

Beef - Hickory, Mesquite, Oak, Grapevines

Pork - Fruitwoods, Hickory, Oak, Sassafras

Lamb - Fruitwoods, Mesquite

Veal - Fruitwoods, Grapevines

Seafood - Alder, Mesquite, Sassafras, Grapevines

Vegetables – Mesquite

USDA Recommended	
Internal Cooking Temperatures	
Ground Meat	
Beef, Pork, Veal, Lamb.....	160°F
Turkey, Chicken.....	165°F
Fresh Beef, Veal, Lamb	
Medium Rare.....	145°F
Medium.....	160°F
Well Done.....	170°F
Poultry	
Chicken & Turkey, whole.....	165°F
Poultry Parts.....	165°F
Duck & Goose.....	165°F
Fresh Pork	
Medium.....	160°F
Well Done.....	170°F

COOKING TIPS

Building Your Fire





- 1.) Stack charcoal briquettes or wood into a pyramid-shaped pile on top of the charcoal grate or ash pan. We recommend using 2 pounds (approximately 20 briquettes) to start your fire.
- 2.) If using lighter fluid, saturate the charcoal briquettes with lighter fluid and let it soak in for approximately 5 minutes. If using a chimney starter, electric starter, or other type of fire starter, light your fire according to the manufacturer's instructions.
- 3.) After allowing the lighter fluid to properly soak in, light the pile of briquettes in several locations to ensure an even burn. ***Always light the fire with the grill lid open.*** Leave lid open until briquettes are fully lit. Failure to do this could trap fumes from charcoal lighter fluid in grill and may result in a flash fire when lid is opened.
- 4.) Never add charcoal lighter fluid to hot or warm coals as flashbacks may occur causing injury.
- 5.) You are ready to begin cooking when the pile of briquettes ashes over and produces a red glow (approximately 12 – 15 minutes).
- 6.) Depending on your cooking method, either leave the briquettes in a pile or spread evenly across the charcoal grate using a long-handled poker.

****Always use caution when handling hot coals to prevent injury.***

Know When Your Fire is Ready

Successful charcoal grilling depends on a good fire. The general rule for knowing when your coals are ready for grilling is to make sure that 80 percent or more of the coals are ashy gray. If you have less than that, the coals are not ready, and if all of them are glowing red hot, the fire is probably too hot. Here are a few steps you can take to adjust the temperature of your fire:

- If it is too hot, spread the coals out a bit more, which makes the fire less intense.
- Raise or lower the adjustable charcoal grate.
- Partially close the vents in the grill, which reduces the amount of oxygen that feeds the fire.
- Use the indirect grilling method, with coals to either side of a drip pan and the food over the pan rather than directly over the coals.
- In the event of a severe flare-up, spray the flames with water from a squirt bottle. Be careful, spraying with water tends to blow ashes around and make a mess.
- Add briquettes 2 or 3 at a time to increase the burn time. Allow 10 minutes for coals to ash over before adding more.

THE HEAT OF THE COALS			
	seconds you can hold the palm of your hand 4 inches above the coals	temperature range (F°)	visual cues
 HOT COALS	2	400 to 450	barely covered with gray ash; deep red glow
 MODERATELY HOT TO HOT COALS	3	375 to 450	thin coating of gray ash; deep red glow
 MODERATELY HOT COALS	4	325 to 375	significant coating of gray ash; red glow
 MODERATELY COOL COALS	5	300 to 325	thick coating of gray ash; dull red glow

GRILL MAINTENANCE

Frequency of cleanup is determined by how much your smoker is used. Make sure coals are completely extinguished before cleaning inside of smoker. Inside surfaces may be cleaned with a strong solution of detergent and water applied with a scrub brush. Thoroughly rinse with water and allow to air dry before using again.

If a bristle brush is used to clean any of the grill cooking surfaces, ensure no loose bristles remain on cooking surfaces prior to grilling. It is not recommended to clean cooking surfaces while grill is hot.

HELPFUL HINTS

- If food seems to be getting too smoky or brown before the cooking time is finished, cover it loosely with heavy duty aluminum foil.
- Remove the ash after each use.
- Covered side dishes can be warmed in smoker chamber.
- To prevent flare-ups, brush meat lightly with oil before grilling.
- Keep a small squirt bottle of water handy for grilling flare-ups.



LIMITED WARRANTY

This warranty only applies to units purchased from an authorized retailer. Manufacturer warrants to the **original consumer-purchaser** only that this product shall be free from defects in workmanship and materials after correct assembly and under normal and reasonable home use for the periods indicated below beginning on the date of purchase*. The manufacturer reserves the right to require that defective parts be returned, postage and or freight pre-paid by the consumer for review and examination.

<u>SCOPE OF COVERAGE</u>	<u>PERIOD OF COVERAGE</u>	<u>TYPE OF FAILURE COVERAGE</u>
All Parts	90 days from date of purchase*	PERFORATION, MANUFACTURING, AND MATERIAL DEFECTS ONLY

*Note: A dated sales receipt WILL be required for warranty service.

The original consumer-purchaser will be responsible for all shipping charges for parts replaced under the terms of this limited warranty.

This limited warranty is applicable in the United States and Canada only, is only available to the original owner of the product and is not transferable. **Manufacturer requires proof of your date of purchase. Therefore, you should retain your sales slip or invoice.** Registering your product is not a substitute for proof of purchase and the manufacturer is not responsible for or required to retain proof of purchase records.

This limited warranty applies to the functionality of the product ONLY and does not cover cosmetic issues such as scratches, dents, corrossions or discoloring by heat, abrasive and chemical cleaners or any tools used in the assembly or installation of the appliance, surface rust, or the discoloration of stainless steel surfaces. **RUST is not considered a manufacturing or materials defect.**

This limited warranty will not reimburse you for the cost of any inconvenience, food, personal injury or property damage.

ITEMS MANUFACTURER WILL NOT PAY FOR:

1. Shipping cost, standard or expedited, for warranty and replacement parts
2. Service calls to your home.
3. Repairs when your product is used for other than normal, single-family household or residential use.
4. Damage, failures, or operating difficulties resulting from accident, alteration, careless handling, misuse, abuse, fire, flood, acts of God, improper installation or maintenance, installation not in accordance with electrical or plumbing codes, or use of products not approved by the manufacturer.
5. Any food loss due to product failures or operating difficulties.
6. Replacement parts or repair labor costs for units operated outside the United States or Canada.
7. Pickup and delivery of your product.
8. Repairs to parts or systems resulting from unauthorized modifications made to the product.
9. The removal and/or reinstallation of your product.

DISCLAIMER OF IMPLIED WARRANTIES and LIMITATION OF REMEDIES

Repair or replacement of defective parts is your exclusive remedy under the terms of this limited warranty. In the event of parts availability issues, the manufacturer reserves the right to substitute like or similar parts that are equally functional.

Manufacturer will not be responsible for any consequential or incidental damages arising from the breach of either this limited warranty or any applicable implied warranty, or for failure or damage resulting from acts of God, improper care and maintenance, grease fire, accident, alteration, replacement of parts by anyone other than Manufacturer, misuse, transportation, commercial use, abuse, hostile environments (inclement weather, acts of nature, animal tampering), improper installation or installation not in accordance with local codes or printed manufacturer instructions.

THIS LIMITED WARRANTY IS THE SOLE EXPRESS WARRANTY GIVEN BY THE MANUFACTURER. NO PRODUCT PERFORMANCE SPECIFICATION OR DESCRIPTION WHEREVER APPEARING IS WARRANTED BY MANUFACTURER EXCEPT TO THE EXTENT SET FORTH IN THIS LIMITED WARRANTY. ANY IMPLIED WARRANTY PROTECTION ARISING UNDER THE LAWS OF ANY STATE, INCLUDING IMPLIED WARRANTY OF MERCHANTABILITY OR FITNESS FOR A PARTICULAR PURPOSE OR USE, IS HEREBY LIMITED IN DURATION TO THE DURATION OF THIS LIMITED WARRANTY.

Neither dealers nor the retail establishment selling this product has any authority to make any additional warranties or to promise remedies in addition to or inconsistent with those stated above. Manufacturer's **maximum liability**, in any event, shall not exceed the purchase price of the product paid by the original consumer.

NOTE: Some states do not allow an exclusion or limitation of incidental or consequential damages, so some of the above limitations or exclusions may not apply to you. This limited warranty gives you specific legal rights as set forth herein. You may also have other rights which vary from state to state. In the state of California only, if refinishing or replacement of the product is not commercially practicable, the retailer selling this product or the Manufacturer will refund the purchase price paid for the product, less the amount directly attributable to use by the original consumer-purchaser prior to discovery of the nonconformity. In addition, in the state of California only, you may take the product to the retail establishment selling this product in order to obtain performance under this limited warranty.

If you wish to obtain performance of any obligation under this limited warranty, you should write to:

**Consumer Relations
P. O. Box 1240
Columbus, GA 31902-1240**

Consumer returns will not be accepted unless a valid Return Authorization is first acquired. Authorized returns are clearly marked on the outside of the package with an RA number and the package is shipped freight/postage pre-paid. Consumer returns that do not meet these standards will be refused.

PARTS LIST

Key	Qty	Description	Key	Qty	Description
1	1	Smoker Chamber Lid Assembly	17	1	Firebox Cook Grate
2	1	Temperature Gauge with Wingnut	18	2	Wheel
3	1	Smoke Stack Assembly	19	1	Firebox Bottom
4	1	Logo Plate Kit	20	2	Leg Support Tube
5	2	End Caps for Legs	21	2	Leg With End Caps
6	2	Hinge Kit	22	2	Leg For Wheels
7	2	Smoker Chamber Cook Grates	23	2	Leg Brace
8	1	Grease Cup Clip	24	1	Firebox Door
9	3	Fire Grates	25	2	Hinges for Firebox Door
10	1	Axle	26	1	Damper Door
11	1	Side Shelf Assembly	—	1	Hardware Pack
12	1	Shelf Support	---	1	Assembly Instructions, English
13	1	Smoker Chamber Bottom	—	1	Assembly Instructions, Spanish
14	1	Firebox Lid			
15	3	Handle Rod			
16	3	Handle Barrel Spring			

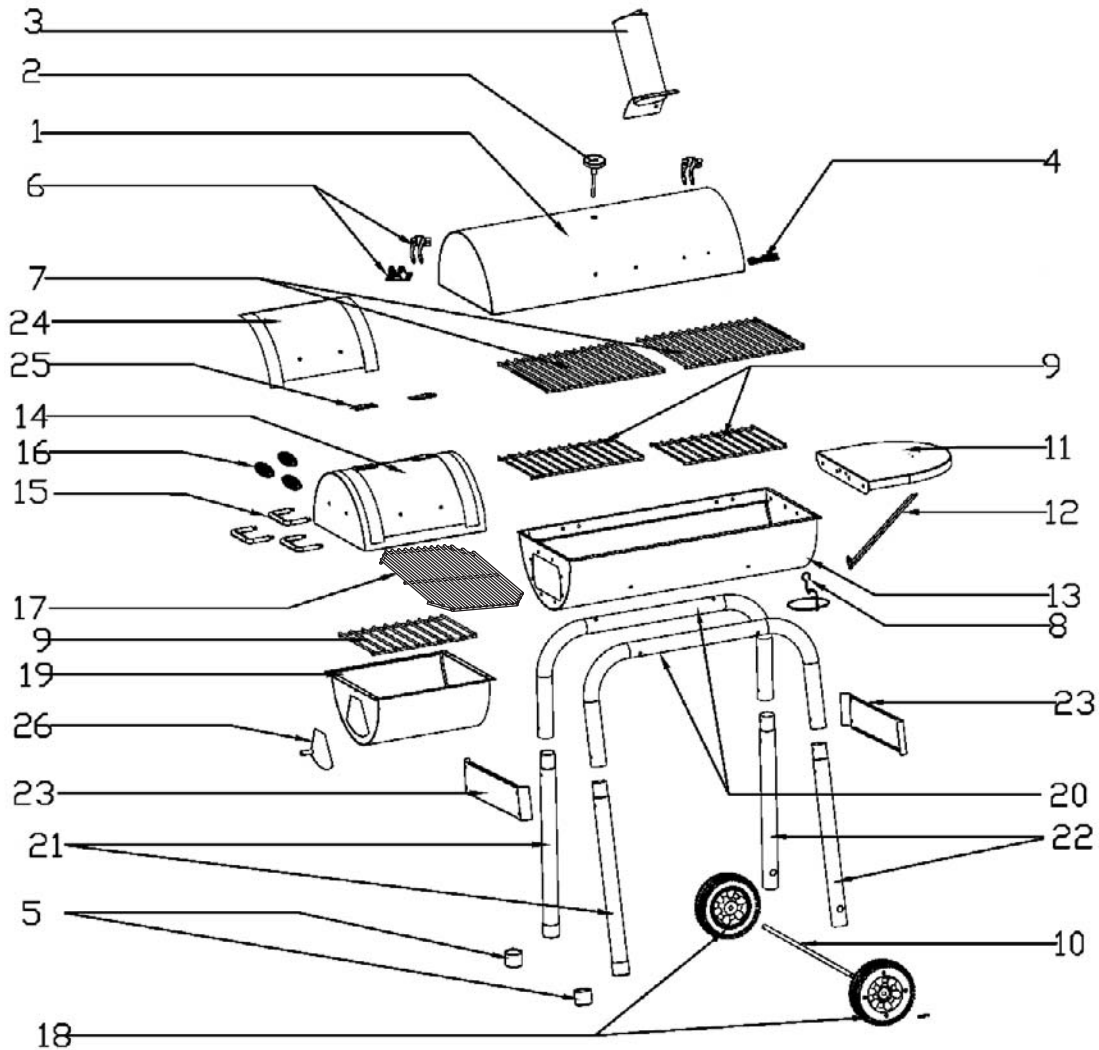

ASSEMBLY

1 FIRST, GET A HELPER! This unit is heavy and requires a second person for lifting and moving. **NEXT**, pick a suitable location to work. Open the carton and slit the corners so that the carton lays flat. This will give you a protective surface during assembly.

- Attach leg supports to smoker chamber using two **1/4-20 X 1-3/4"** screws and two **1/4-20** flange nuts on each side.

Finger tighten screws and nuts until after next step.

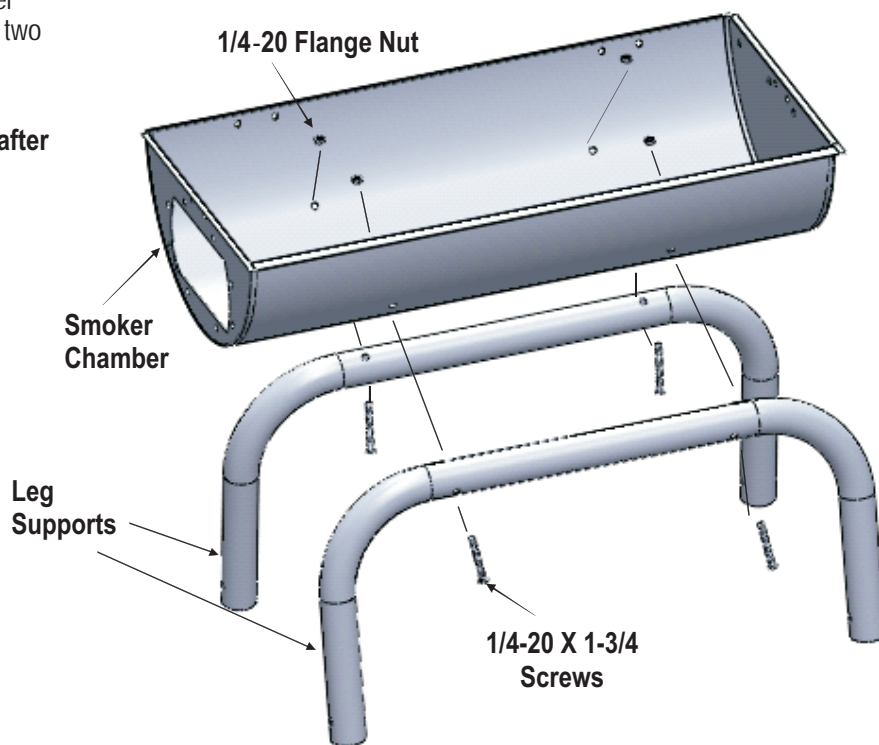

2

- Lay unit on smoker chamber.
- Insert legs into leg supports making sure holes align and the legs with caps are at the chamber side opening.
- Attach leg brace on each side using four **1/4-20 X 1-3/4"** screws and four **1/4-20** flange nuts per brace.

Finger tighten all screws and nuts in this step until all are in place. Once all in place, then fully tighten all screws and nuts. Go back and fully tighten screws and nuts in step 1.

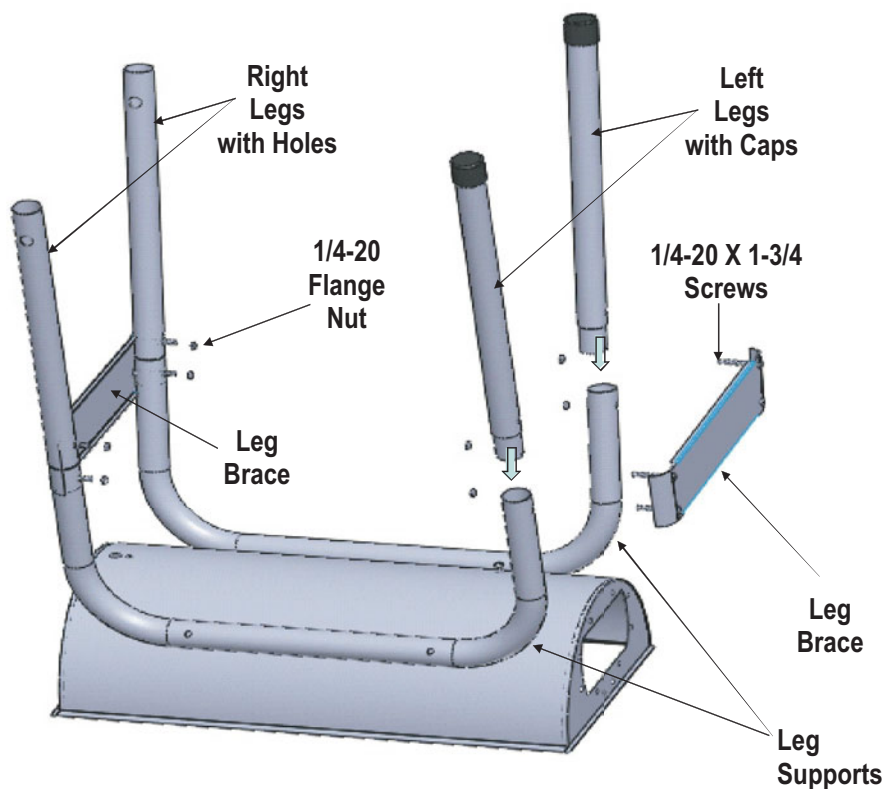

3

- Slide axle into holes at ends of legs (legs without end caps).
- Attach wheels onto axle rod using hitch pins. Hitch pins insert through hole in axle as shown in box A.

Check to be sure that all screws and nuts used so far are fully tightened.

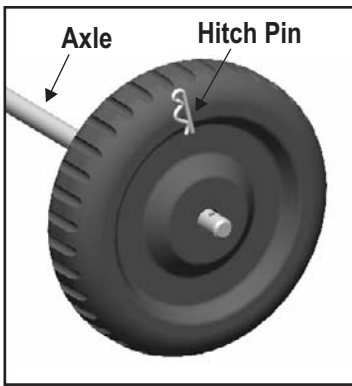

Figure B

4

- Pre-assemble the Firebox Lid and the Firebox Bottom using eight #6-32 X 3/8 Screws as shown in figure A.
- Place the firebox onto the smoker chamber and align the large openings.
- Insert eight #10-24 X 1/2" screws through the smoker chamber, into the firebox. Secure with eight #10-24 flange nuts as shown in figure B.

Fully tighten all screws and nuts.

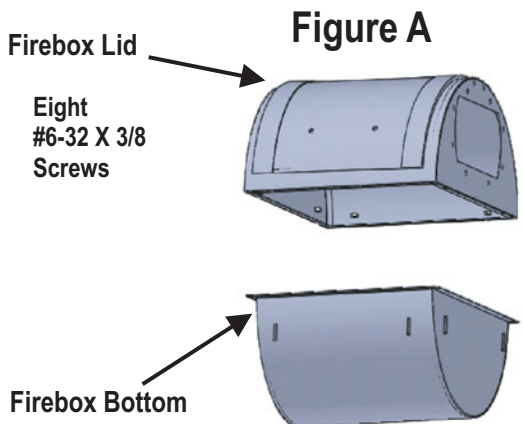
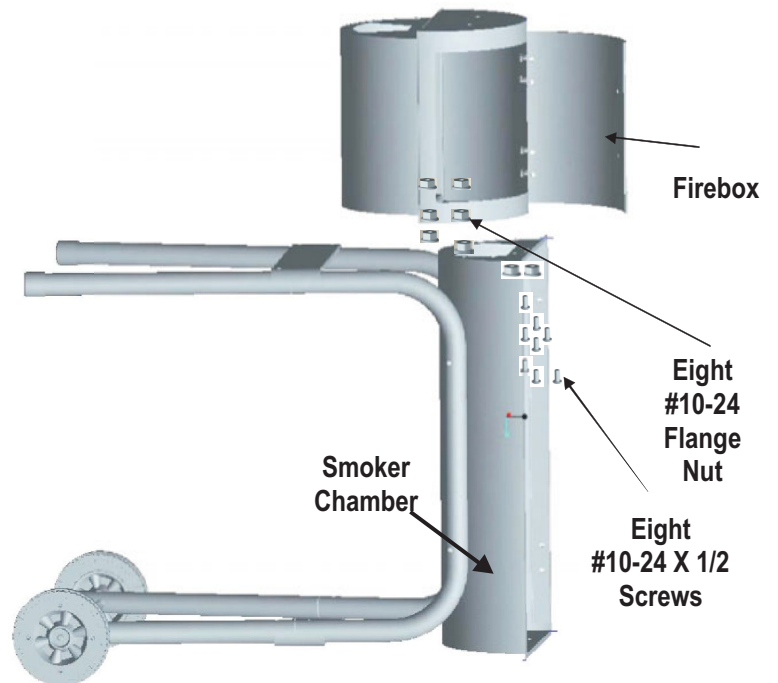
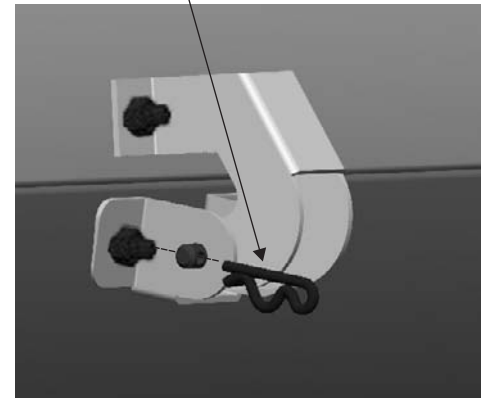
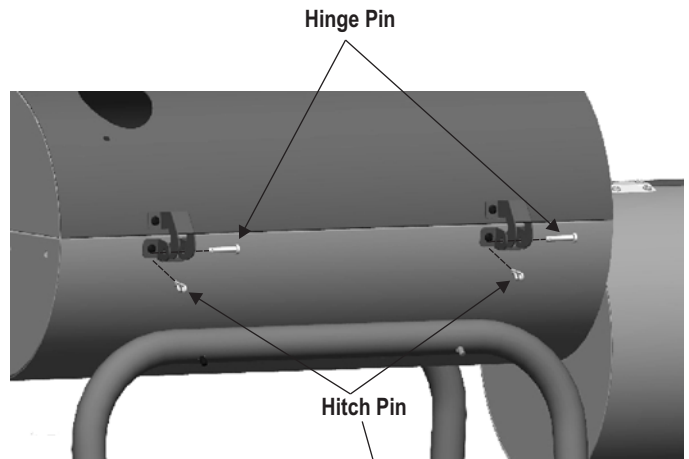
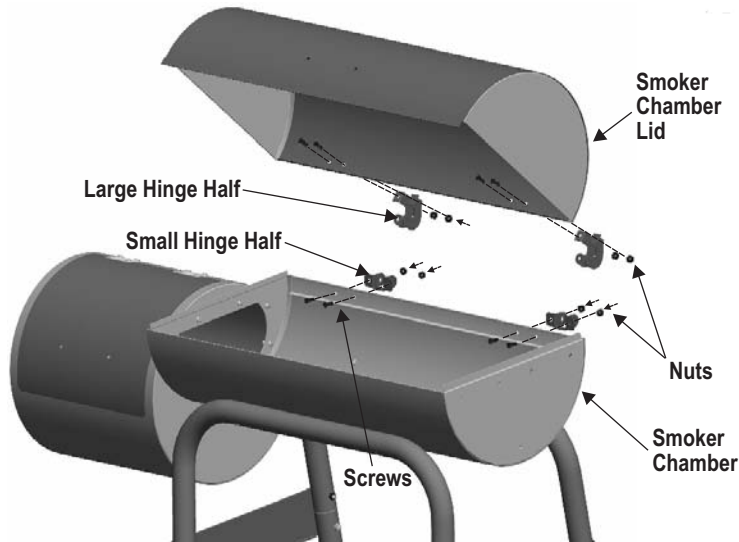

Figure A



- 5**
- Place unit in upright position.
 - Attach small hinge half to smoker chamber using two #10-24 X 1/2" screws and two #10-24 flange nuts for each hinge half. Install screws from inside the smoker chamber.
 - Attach large hinge half to smoker chamber lid using two #10-24 X 1/2" screws and two #10-24 flange nuts for each hinge half. Install screws from inside the smoker chamber lid.
 - Insert top hinge in between bottom hinge and secure using one hinge pin and one hitch pin for each hinge set.

Finger tighten all screws and nuts in this step until all are in place. Once all are in place, close the lid and fully tighten all screws and nuts.



6

- Insert smoke stack through smoker chamber lid, aligning holes.
- Attach using two #10-24 X 1/2" screws and two #10-24 flange nuts.

Fully tighten all screws and nuts.

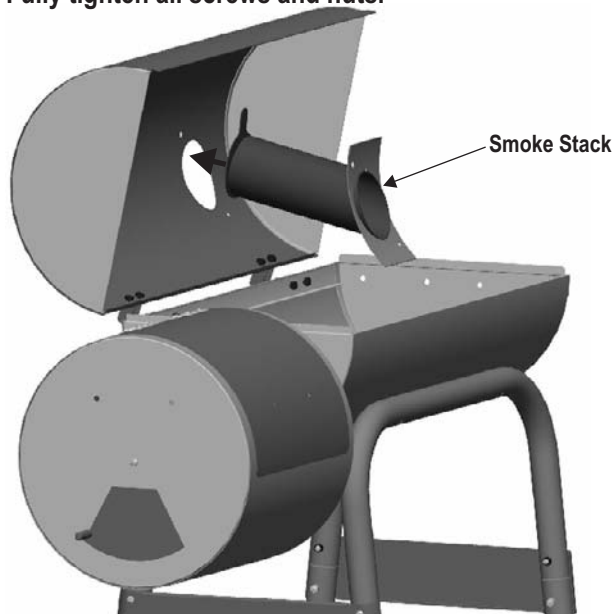

NOTE: Lid side wall shown transparent for clarity

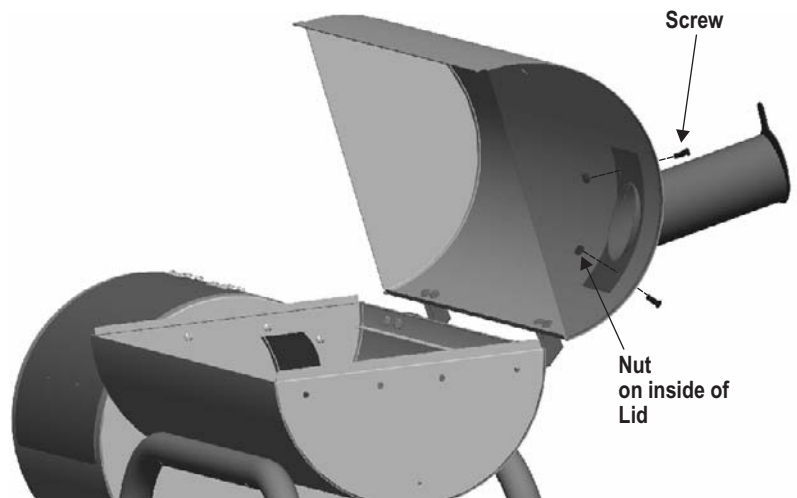

7

NOTE: The temperature gauge may be packed inside of the smokestack to prevent damage during shipping. If so, remove gauge before assembling smokestack to chamber.

- Place fiber washers on handle rods.
- Place the handle assembly into the holes on the front of the smoker chamber door and secure with two **1/4-20** flange nuts.
- Repeat on firebox door.
- Insert spring handle through holes on the side of firebox and secure with two **1/4-20** flange nuts.

Fully tighten all screws and nuts.

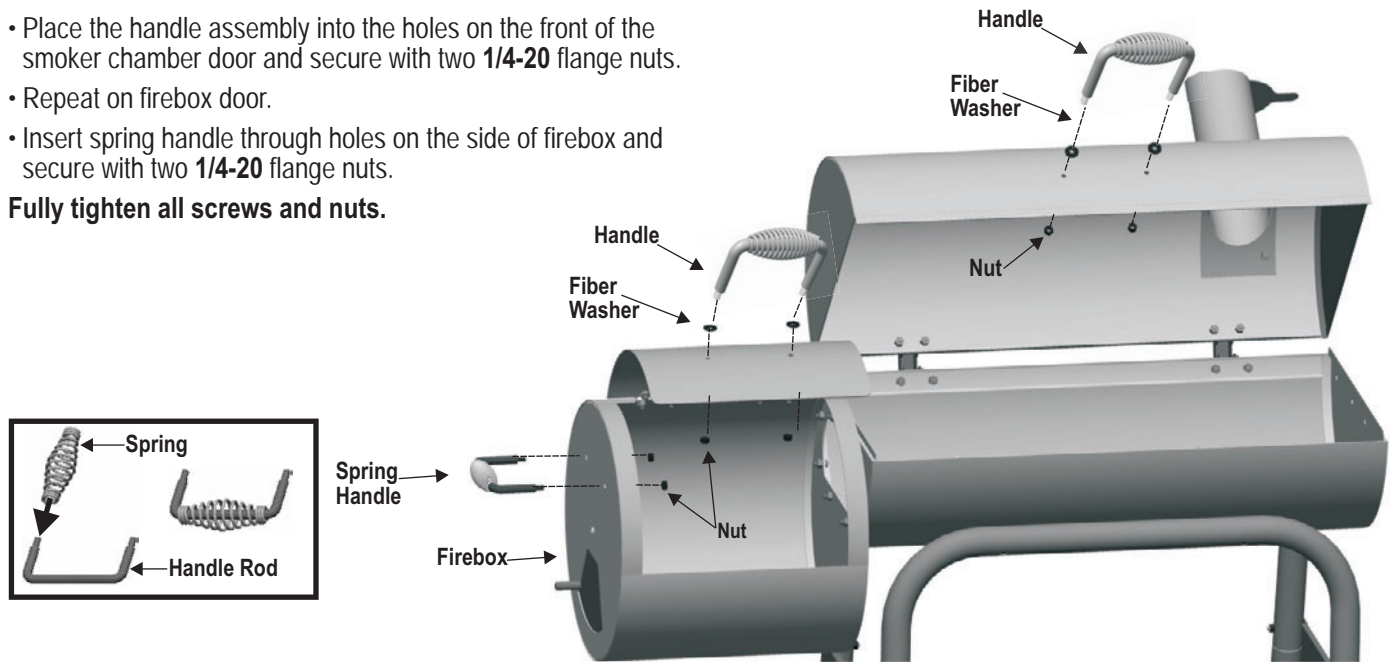

8

- Remove **wing nut** from temperature gauge.
- Insert temperature gauge through smoker chamber lid hole above handle securing it from the underside with the **wing nut** removed aligning the gauge settings before fully tightening.
- Insert logo plate through smoker chamber lid holes to the right of the handle, securing it from the underside of the lid with two **logo clips**.

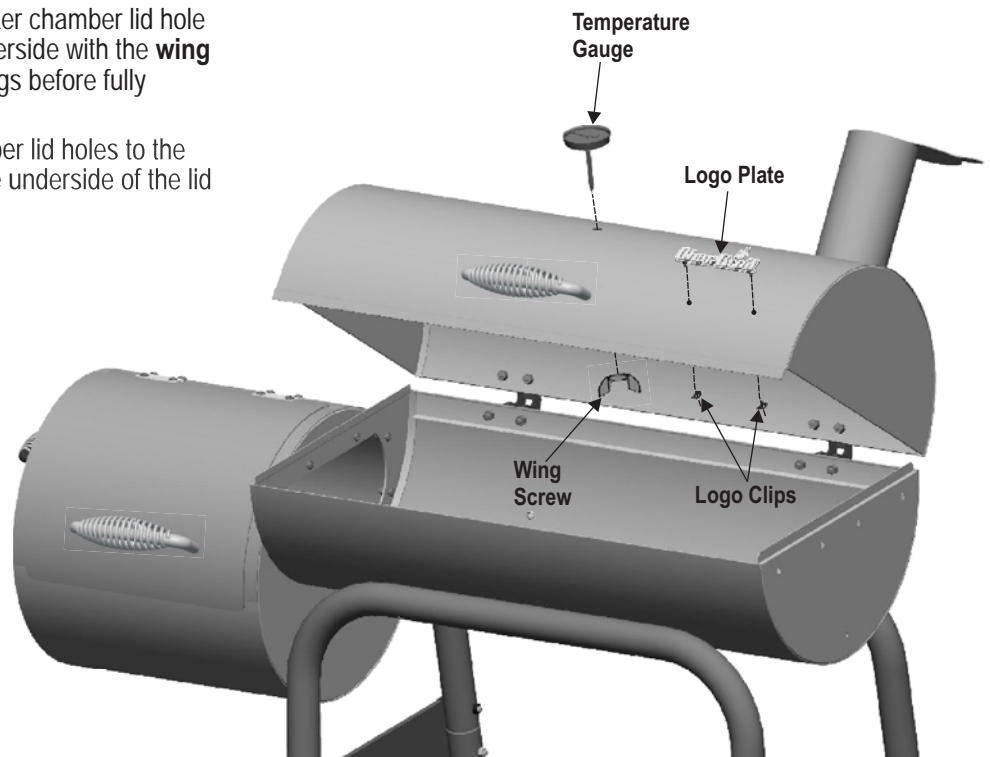

9

- Attach shelf support to side of smoker chamber with one **#10-24 X 1/2"** machine screw where screw is going through inside of chamber through hole of support and secured with one **#10-24** flange nut.
- Lay side shelf on top of other end of shelf support so that it fits inside holding bracket.
- Secure side shelf to smoker chamber using two **#10-24 X 1/2"** screws and two **#10-24** flanged nuts.

Fully tighten all screws and nuts.

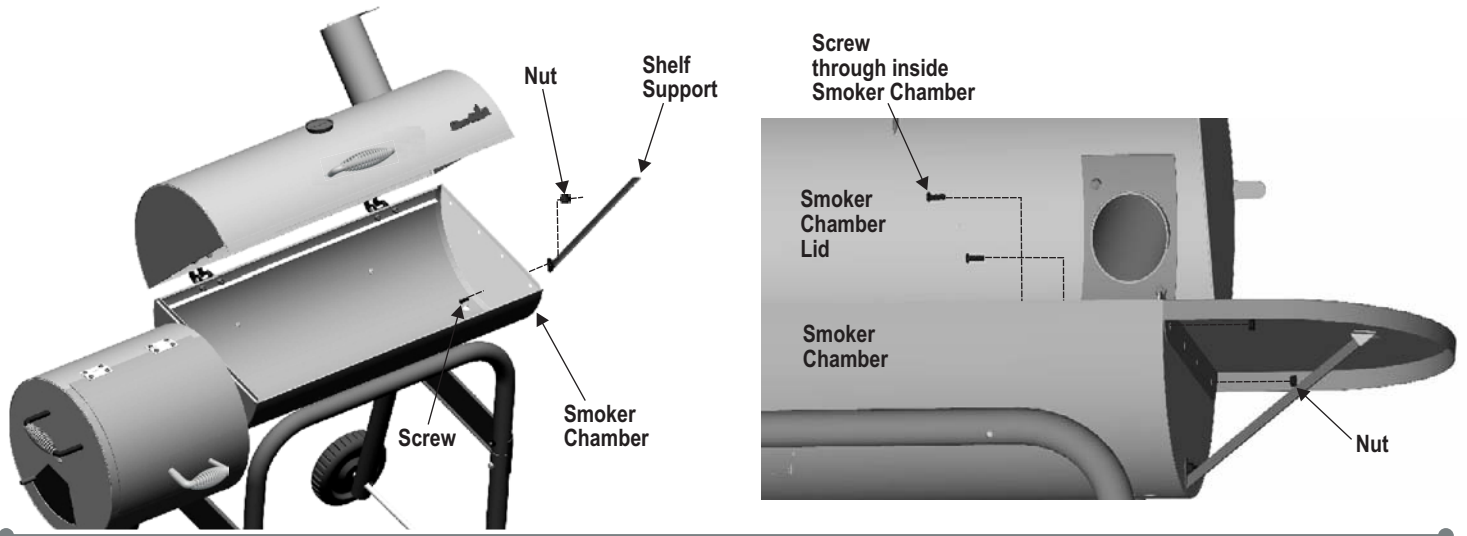
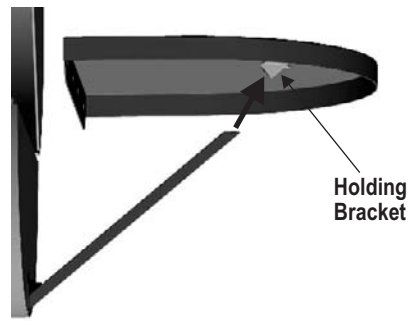

10

- Place a fire grate into the bottom of the firebox. Remaining fire grates may be placed in the bottom of the smoker chamber, if desired.
- The height of the grate can be adjusted by turning it 90 degrees.

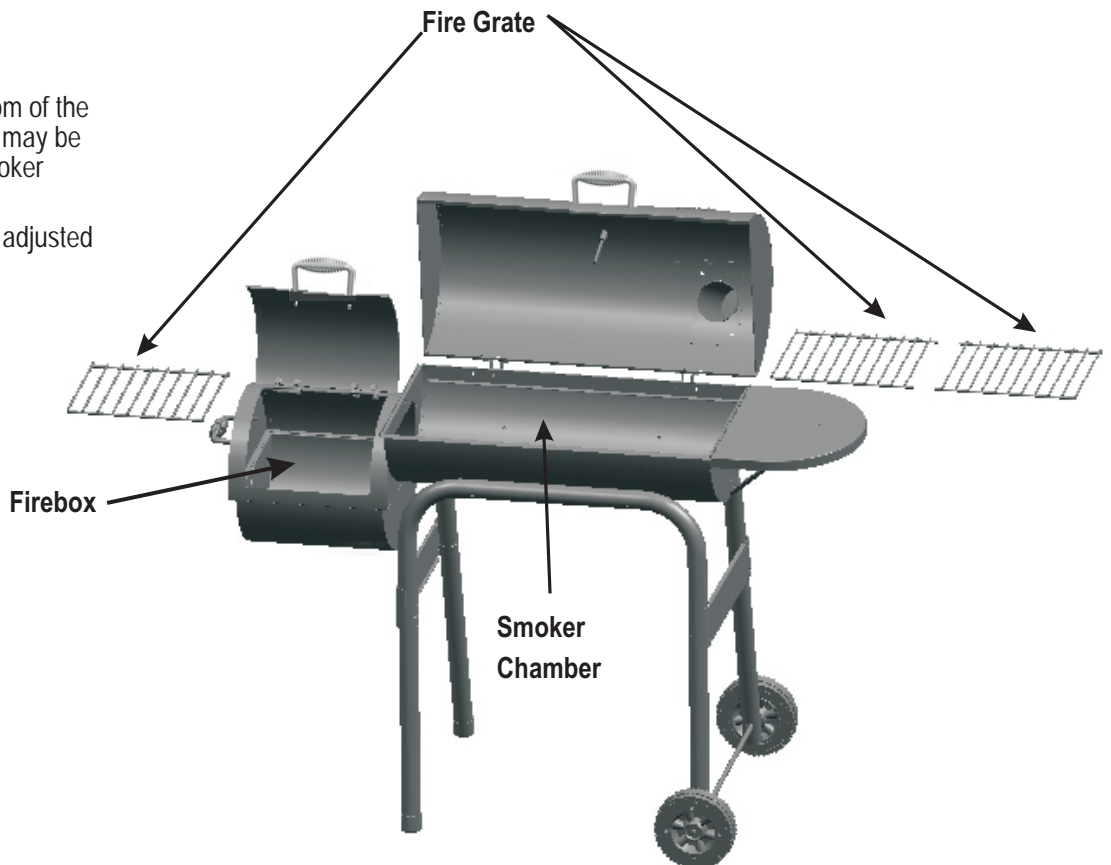

11

- Place two Smoker Chamber Cooking Grates into the smoker chamber.
- Place the Firebox Cook Grate into the Firebox.

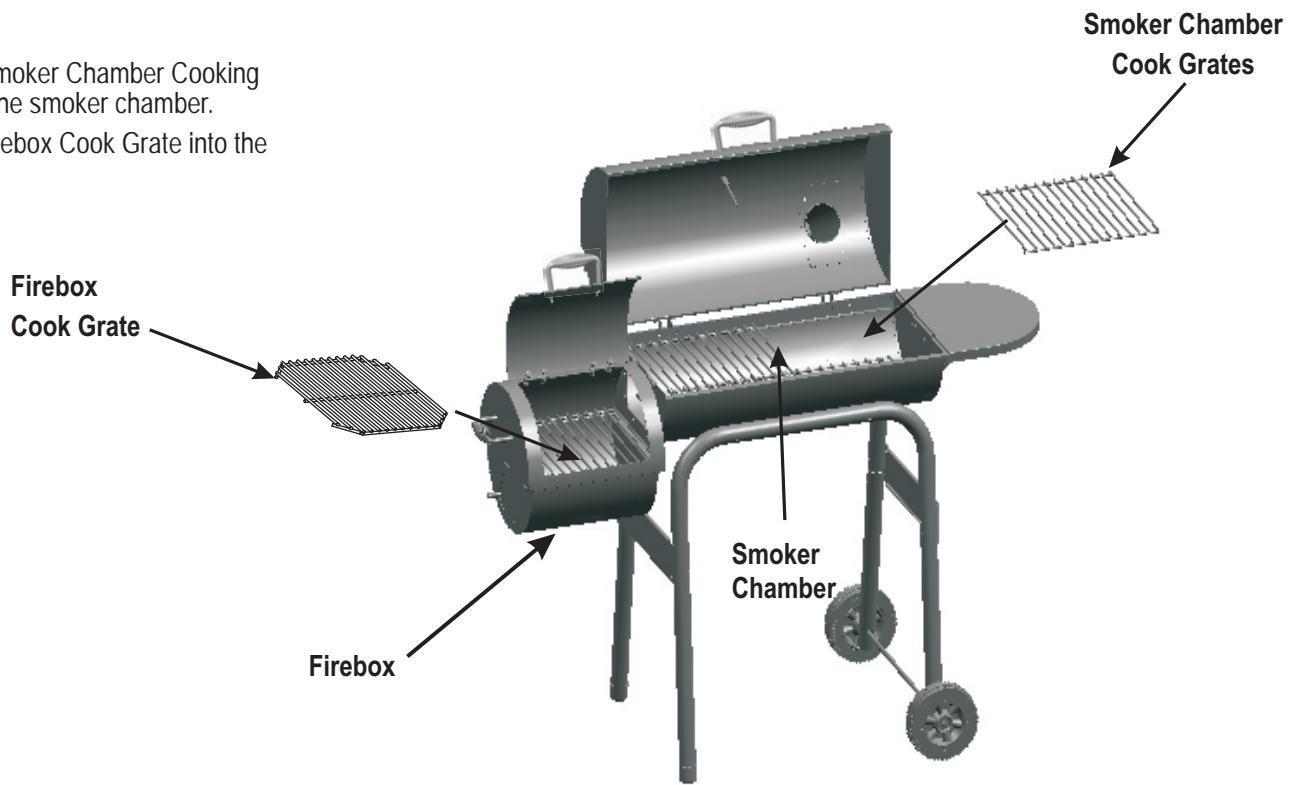

12

- Hang the grease clip under the smoker chamber on right side.
- An empty soup can is recommended to hang from grease clip.

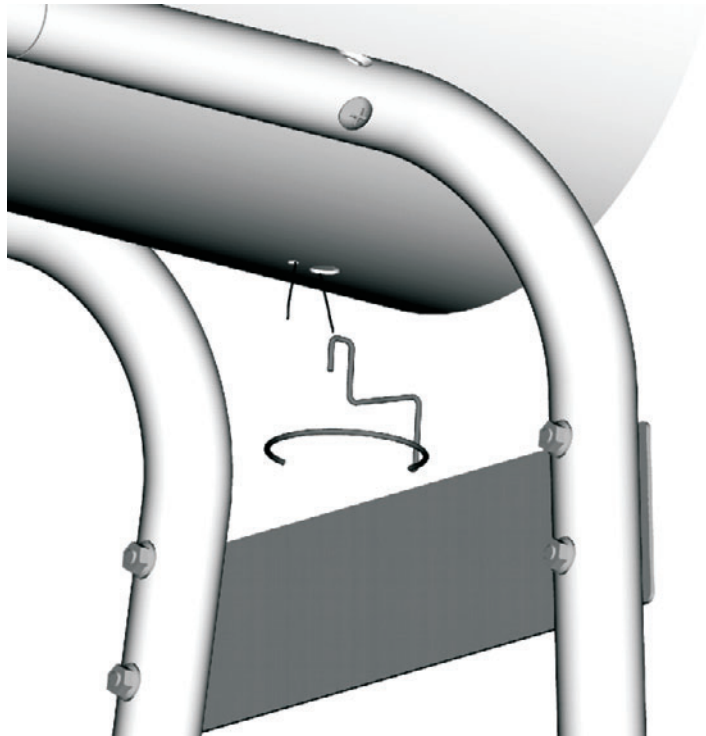

The assembly is completed.

HARDWARE LIST

You may have spare hardware after assembly is complete.

Hardware not shown actual size.

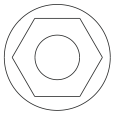

1/4-20
Flange Nut
Qty. 18

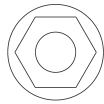

#10-24
Flange Nut
Qty. 21



Logo
Clip
Qty. 2



Hinge Pin
Qty. 2



Hair Pin Clip
Qty. 4



Fiber Washer
Qty. 4

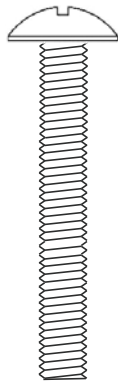

1/4-20 X 1-3/4"
Machine
Screw
Qty. 12

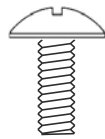

#10-24 x 1/2"
Machine
Screw
Qty. 21

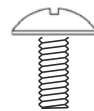

#6-32 X 3/8"
Machine Screw
Qty. 8



Here's what you can find at www.charbroil.com

- Register your Char-Broil® product
- Get information about our products
- Our replacement parts
- Reliable customer support
- Delicious recipes
- Char-Broil® on-line store
- *Sizzle On The Grill*™ E-newsletter
- And much more!



Please visit us at www.charbroil.com and click on the *Buy Online* link to find grilling tools and accessories, maintenance items, covers, grill parts, as well as Char-Broil® grills and cookers. We also have a *Special Offers* section, so be sure to check often for specials deals.



In addition to the online store, charbroil.com offers you a wealth of information regarding Char-Broil® gas, charcoal, electric, and new infrared grills and cookers.

Be sure to check out our many grilling recipes and don't forget to sign up for our exciting newsletter *Sizzle on the Grill*™ to stay updated on new recipes, contests, and the latest happenings here at Char-Broil®.

Charbroil.com also offers on-line customer support for Char-Broil® products.



**Thank you for support, and
HAPPY GRILLING!**

www.charbroil.com
For all your grilling needs!

Please register your product online at:

www.charbroil.com/register

(If you register online, you do not need to send in this registration card.)

PLEASE FILL OUT THIS CARD AND ATTACH A COPY OF YOUR SALES RECEIPT. RETURN IT WITHIN 10 DAYS OF PURCHASE. FAILURE TO RETURN MAY AFFECT YOUR WARRANTY COVERAGE. FOR WARRANTY SERVICE PROOF OF PURCHASE WILL BE REQUIRED. THIS WARRANTY IS NON-TRANSFERABLE.

LENE ESTA TARJETA Y DEVUELVALA DENTRO DE LOS 10 DIAS DE LA COMPRA. SI NO LA DEVUELVE, PUEDE VERSE AFECTADA SU COBERTURA DE GARANTIA. PARA EL SERVICIO DE GARANTIA ES NECESARIO QUE PRESENTE SU COMPROBANTE DE COMPRA. CONSERVE LA FACTURA. ESTA GARANTIA ES INTRANSFERIBLE.

VEUILLEZ COMPLETER CETTE CARTE ET LA RETOURNER DANS LES 10 JOURS SUIVANT L'ACHAT. LA COUVERTURE DE VOTRE GARANTIE POURRAIT EN ETRE AFFECTEE SI VOUS NE LE FAITES PAS. POUR OBTENIR LE SERVICE SOUS GARANTIE, UNE PREUVE D'ACHAT DOIT ETRE PRESENTEE. VEUILLEZ CONSERVER VOTRE FACTURE. LA PRESENTE GARANTIE N'EST PAS TRANSFERABLE.

1 First Name/Nombre/Prénom Initial/Inicial/Initiale Last Name/Apellido/Nom de famille

Address (number and street)/Dirección (número y calle)/Adresse (numéro et rue) Apt Number/Nº de apart./Nº d'appt.

City/Ciudad/Ville State/Estado/Province Zip Code/Código Zip/Code postal

2 E-mail Address/Dirección de correo electrónico/Adresse électronique

If you voluntarily provide us with your email address, you give us permission to use your email address to send you offers that may interest you.

Si nos informa voluntariamente su dirección de correo electrónico, nos da permiso para usarlo a fin de enviarle ofertas que pueden interesarle.

Si vous choisissez de nous fournir votre adresse électronique, vous nous donnez la permission de l'utiliser pour vous faire part d'offres spéciales susceptibles de vous intéresser.

(Example: your name @ your host.com) (Ejemplo: su nombre@su host.com) (Exemple : votre nom@votre hôte.com)

10 Attach copy of your sales receipt here

Adjunte aquí la copia de su recibo de compra
Veillez attacher une copie de votre reçu ici.

3 Phone Number/Número telefónico/Numéro de téléphone

6 Date of Purchase/Fecha de compra/Date de l'achat

4 **IMPORTANT! ¡IMPORTANTE! IMPORTANT!**
Write Serial Number and Model Number in spaces below.
Escriba en los espacios de abajo el número de serie y el número de modelo.
Inscrivez le numéro de série et le numéro de modèle dans les espaces ci-dessous.

7 Store Name/Nombre de la tienda/Nom du magasin

8 Purchase Price/Precio de compra/Prix d'achat

\$ _____ .00

5 Your Gender/Sexo/Sexe :

1. Male/Masculino/Masculin

2. Female/Femenino/Féminin

9 Which product are you registering?

¿Qué producto está registrando?

Quel produit enregistrez-vous?

1. Gas Grill/Parrilla a gas/Gril au gaz
2. Electric Grill/Parrilla eléctrica/Gril électrique
3. Smoker/Ahumador/Fumoir
4. Charcoal Grill/Parrilla a carbón/Barbecue au charbon
5. Charcoal Smoker/Ahumador a carbón/Fumoir au charbon
6. Outdoor Fireplace/Chimenea para exteriores/Foyer extérieur
7. Cooker/Fryer / Cocina/freidora / Cuiseur/Friteuse
8. Other/Otro/Autre

Mail to: / Envíelo a:

**Warranty Registration Department
P.O. Box 1240
Columbus, GA 31902-1240**

Thank you for completing this questionnaire. Your answers will help us and other companies reach you with offers that may interest you. If you prefer not to receive these offers, please check here

Gracias por completar este cuestionario. Sus respuestas nos ayudarán, a nosotros y a otras compañías, a llegar a usted con ofertas que puedan resultarle de interés. Si prefiere no recibir estas ofertas, por favor marque aquí .

Merci d'avoir bien voulu remplir ce questionnaire. Vos réponses nous aideront et aideront d'autres compagnies à vous communiquer des offres spéciales susceptibles de vous intéresser. Si vous préférez ne pas recevoir d'informations concernant ces offres spéciales, veuillez cocher ici .

REGTEMP REV02

Free Manuals Download Website

<http://myh66.com>

<http://usermanuals.us>

<http://www.somanuals.com>

<http://www.4manuals.cc>

<http://www.manual-lib.com>

<http://www.404manual.com>

<http://www.luxmanual.com>

<http://aubethermostatmanual.com>

Golf course search by state

<http://golfingnear.com>

Email search by domain

<http://emailbydomain.com>

Auto manuals search

<http://auto.somanuals.com>

TV manuals search

<http://tv.somanuals.com>