

**CHICAGO**  
**Electric® Power Tools**

# ELECTRIC STAPLER/NAILER

**Model 93749**

## SET UP AND OPERATING INSTRUCTIONS



Distributed exclusively by Harbor Freight Tools®.

3491 Mission Oaks Blvd., Camarillo, CA 93011

Visit our website at: <http://www.harborfreight.com>



**Read this material before using this product.  
Failure to do so can result in serious injury.  
SAVE THIS MANUAL.**

Copyright© 2005 by Harbor Freight Tools®. All rights reserved. No portion of this manual or any artwork contained herein may be reproduced in any shape or form without the express written consent of Harbor Freight Tools. Diagrams within this manual may not be drawn proportionally. Due to continuing improvements, actual product may differ slightly from the product described herein. Tools required for assembly and service may not be included.

**For technical questions or replacement parts, please call 1-800-444-3353.**

Manual revised 08j

---

## SAVE THIS MANUAL

---

Keep this manual for the safety warnings and precautions, assembly, operating, inspection, maintenance and cleaning procedures. Write the product's serial number in the back of the manual near the assembly diagram (or month and year of purchase if product has no number). Keep this manual and the receipt in a safe and dry place for future reference.

---

## IMPORTANT SAFETY INFORMATION

---

In this manual, on the labeling, and all other information provided with this product:



This is the safety alert symbol. It is used to alert you to potential personal injury hazards. Obey all safety messages that follow this symbol to avoid possible injury or death.

### **DANGER**

**DANGER** indicates a hazardous situation which, if not avoided, will result in death or serious injury.

### **WARNING**

**WARNING** indicates a hazardous situation which, if not avoided, could result in death or serious injury.

### **CAUTION**

**CAUTION**, used with the safety alert symbol, indicates a hazardous situation which, if not avoided, could result in minor or moderate injury.

### **NOTICE**

**NOTICE** is used to address practices not related to personal injury.

### **CAUTION**

**CAUTION**, without the safety alert symbol, is used to address practices not related to personal injury.

---

## General Power Tool Safety Warnings



**WARNING** Read all safety warnings and instructions.

*Failure to follow the warnings and instructions may result in electric shock, fire and/or serious injury.*

**Save all warnings and instructions for future reference.**

1. **Keep work area clean.** Cluttered areas invite injuries.
2. **Observe work area conditions.** Do not use machines or power tools in damp or wet locations. Do not expose to rain. Keep work area well lit. Do not use electrically powered tools in the presence of flammable gases or liquids.
3. **Keep children away.** Children must never be allowed in the work area. Do not let them handle tools or extension cords.
4. **Store idle equipment.** When not in use, tools must be stored in a dry location to inhibit rust. Lock up tools and keep out of reach of children.
5. **Use the right tool for the job.** Do not attempt to force a small tool or attachment to do the work of a larger industrial tool. There are certain applications for which this tool was

designed. It will do the job better and more safely at the rate for which it was intended. Do not modify this tool, and do not use this tool for a purpose for which it was not intended.

6. **Dress properly.** Do not wear loose clothing or jewelry as they can be caught in moving parts. Protective, electrically nonconductive clothes and nonskid footwear are recommended when working. Wear restrictive hair covering to contain long hair.

7. **Do not overreach.** Keep proper footing and balance at all times. Do not reach over or across running machines or extension cords.

8.  **Use eye and ear protection.** Always wear ANSI approved impact safety goggles and appropriate hearing protection. Wear a full face shield if you are producing metal filings or wood chips. Wear an ANSI approved dust mask or respirator when working around metal, wood, and chemical dusts and mists. Other people in the work area must also wear ANSI-approved impact safety goggles.

9. **Maintain tools with care.** Keep tools clean for better and safer performance. Follow instructions for lubricating and changing accessories. Inspect tool cords periodically and, if damaged, have them repaired by an authorized technician. The handle must be kept clean, dry, and free from oil and grease at all times. Do not operate a tool if any portion of the tool's operating controls are inoper-

able, disconnected, altered, or not working properly.

10. **Lock the Trigger by moving the Trigger Lock to the right and unplug the tool before service.** Never service the Stapler/Nailer, clear jams, or disassemble with the Trigger unlocked and/or the tool plugged into an electrical outlet.

11. **Avoid unintentional firing.** Lock the Trigger when not in use and before plugging in. Do not carry any tool with your finger on the Trigger, whether it is plugged into an electrical outlet or not. Do not point the tool towards yourself or anyone whether it contains staples/nails or not.

12. **Stay alert.** Watch what you are doing. Use common sense. Do not operate any tool when you are tired.

13. **Check for damaged parts.** Before using any tool, any part that appears damaged should be carefully checked to determine that it will operate properly and perform its intended function. Check for alignment and binding of moving parts, any broken parts or mounting fixtures, and any other condition that may affect proper operation. Any part that is damaged should be properly repaired or replaced by a qualified technician. Do not use the tool if the trigger does not operate properly.

14. **Guard against electric shock.** Prevent body contact with grounded surfaces such as pipes, radiators, ranges, and refrigerator enclosures.

15. **Replacement parts and accessories.** This product is to be repaired and serviced only by a qualified

- technician. When this product is serviced, only identical replacement parts should be used. Use of any other parts will void the warranty. Only use accessories intended for use with this tool. Approved accessories are available from Harbor Freight Tools.
16. **Do not operate tool if under the influence of alcohol or drugs.** Read warning labels if taking prescription medicine to determine if your judgment or reflexes are impaired while taking drugs. If there is any doubt, do not operate the tool.
  17. **Maintenance.** The maintenance outlined in the "Maintenance" section should be performed regularly. For your safety, this product should be serviced or repaired regularly only by a qualified technician.
  18. **Do not load fasteners with the Trigger unlocked and/or the tool plugged into an electrical outlet.** Unintentional firing may occur. Always assume the tool contains fasteners.
  19. **Fire fasteners into an appropriate work surface only.** Do not attempt to fire fasteners into surfaces too hard to penetrate. Do not drive fasteners on top of other fasteners, or at too steep an angle. Nails can ricochet, causing personal injury. Never fire the Stapler/Nailer into the air, or point it toward yourself or another person. Always wear ANSI approved impact safety goggles during use, maintenance, and reloading.
  20. **Do not fire fasteners too close to the edge of a workpiece.** They may split the workpiece and fly free, causing personal injury.
  21. **Hold tool away from head and body.** During operation the Nailer may kick back, causing injury.
  22. **Avoid working alone.** If an accident happens, an assistant can bring help.
  23. **Take caution, as some woods contain preservatives such as copper chromium arsenate (CCA) which can be toxic.** When nailing these materials extra care should be taken to avoid inhalation and minimize skin contact.
  24. **WARNING:** Some dust created by power sanding, sawing, grinding, drilling, and other construction activities contain chemicals known (to the State of California) to cause cancer, birth defects, or other reproductive harm. Some examples of these chemicals are:
    - \* Lead from lead-based paints,
    - \* Crystalline silica from bricks, cement, and other masonry products,
    - \* Arsenic and chromium from chemically treated lumber.*(California Health & Safety Code 25249.5, et seq.)*
  25. **Maintain labels and nameplates on the Stapler/Nailer.** These carry important information. If unreadable or missing, contact Harbor Freight Tools for a replacement.
  26. **Industrial applications must follow OSHA guidelines.**
  27. The warnings, cautions, and instructions discussed in this instruction manual cannot cover all possible conditions and situations that may occur. It must be understood by the operator

that common sense and caution are factors which cannot be built into this product, but must be supplied by the operator.

---

## GROUNDING

---

### **⚠ WARNING** TO PREVENT ELECTRIC SHOCK



#### AND DEATH FROM INCORRECT GROUNDING WIRE CONNECTION:

Check with a qualified electrician if you are in doubt as to whether the outlet is properly grounded. Do not modify the power cord plug provided with the tool. Never remove the grounding prong from the plug. Do not use the tool if the power cord or plug is damaged. If damaged, have it repaired by a service facility before use. If the plug will not fit the outlet, have a proper outlet installed by a qualified electrician.

### Double Insulated Tools: Tools with Two Prong Plugs

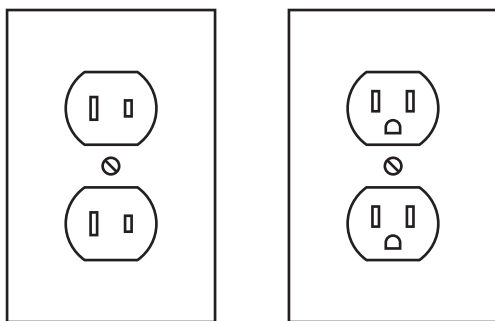

Outlets for 2-Prong Plug

1. Tools marked "Double Insulated" do not require grounding. They have a special double insulation system which satisfies OSHA requirements

and complies with the applicable standards of Underwriters Laboratories, Inc., the Canadian Standard Association, and the National Electrical Code. (See **Outlets for 2-Prong Plug.**)





2. Double insulated tools may be used in either of the 120 volt outlets shown in the preceding illustration. (See **Outlets for 2-Prong Plug.**)

### Extension Cords

1. **Grounded** tools require a three wire extension cord. **Double Insulated** tools can use either a two or three wire extension cord.
2. As the distance from the supply outlet increases, you must use a heavier gauge extension cord. Using extension cords with inadequately sized wire causes a serious drop in voltage, resulting in loss of power and possible tool damage. (See **Table A.**)
3. The smaller the gauge number of the wire, the greater the capacity of the cord. For example, a 14 gauge cord can carry a higher current than a 16 gauge cord. (See **Table A.**)
4. When using more than one extension cord to make up the total length, make sure each cord contains at least the minimum wire size required. (See **Table A.**)
5. If you are using one extension cord for more than one tool, add the nameplate amperes and use the sum to determine the required minimum cord size. (See **Table A.**)

6. If you are using an extension cord outdoors, make sure it is marked with the suffix "W-A" ("W" in Canada) to indicate it is acceptable for outdoor use.
7. Make sure the extension cord is properly wired and in good electrical condition. Always replace a damaged extension cord or have it repaired by a qualified electrician before using it.
8. Protect the extension cords from sharp objects, excessive heat, and damp or wet areas.

### Symbology

	Double Insulated
	Canadian Standards Association
	Underwriters Laboratories, Inc.
	Volts Alternating Current
	Amperes
$n_0$ xxxx/min.	No Load Revolutions per Minute (RPM)

<b>RECOMMENDED MINIMUM WIRE GAUGE FOR EXTENSION CORDS* (120/240 VOLT)</b>					
<b>NAMEPLATE AMPERES (at full load)</b>	<b>EXTENSION CORD LENGTH</b>				
	<b>25'</b>	<b>50'</b>	<b>75'</b>	<b>100'</b>	<b>150'</b>
0 – 2.0	18	18	18	18	16
2.1 – 3.4	18	18	18	16	14
3.5 – 5.0	18	18	16	14	12
5.1 – 7.0	18	16	14	12	12
7.1 – 12.0	18	14	12	10	-
12.1 – 16.0	14	12	10	-	-
16.1 – 20.0	12	10	-	-	-
<b>TABLE A</b> * Based on limiting the line voltage drop to five volts at 150% of the rated amperes.					



## SPECIFICATIONS

Electrical Requirements	120 V~ / 60 Hz / 6A
Staple Type	1/4", 5/16", 1/2", 9/16" or Arrow T50®
Nail Type	9/16"
Accessories	3/8" Staples (Qty. 400) 9/16" Nails (Qty. 100)

**Note:** Performance of the Stapler/Nailer may vary depending on variations in local line voltage. Extension cord usage may also affect the tool performance.

## UNPACKING

When unpacking, make sure that the item is intact and undamaged. If any parts are missing or broken, please call Harbor Freight Tools at the number shown on the cover of this manual as soon as possible.

## LOADING

### **⚠ WARNING** TO PREVENT SERIOUS INJURY:

**Wear ANSI-approved impact safety goggles when reloading or performing any other maintenance on this tool. Other people in the work**

area must also wear ANSI-approved impact safety goggles.

1. **Lock the Trigger (10) by moving the Trigger Lock (3) to the right and unplug the tool before loading.**

**Note:** To lock the Trigger (10), move the Trigger Lock (3) to the *right*. To unlock the Trigger, move the Trigger Lock to the *left*.

2. **Test for proper operation of the Trigger Lock by attempting to fire a fastener into a piece of scrap wood while the Trigger is locked (the tool should not fire). (See Figure H.)**
3. Push forward on the Pusher Cover (2) and slightly downward to remove the Pusher assembly. **(See Figure D.)**
4. Once removed, insert one strip of Staples (46) or Nails (47) in the Inner Staple Slot (1-1). **Do not load Staples and Nails together. (See Figures E, F.)**
5. Reinsert the Pusher assembly into the Stapler/Nailer, making sure the Pusher Cover (2) locks securely in place. **(See Figure G.)**

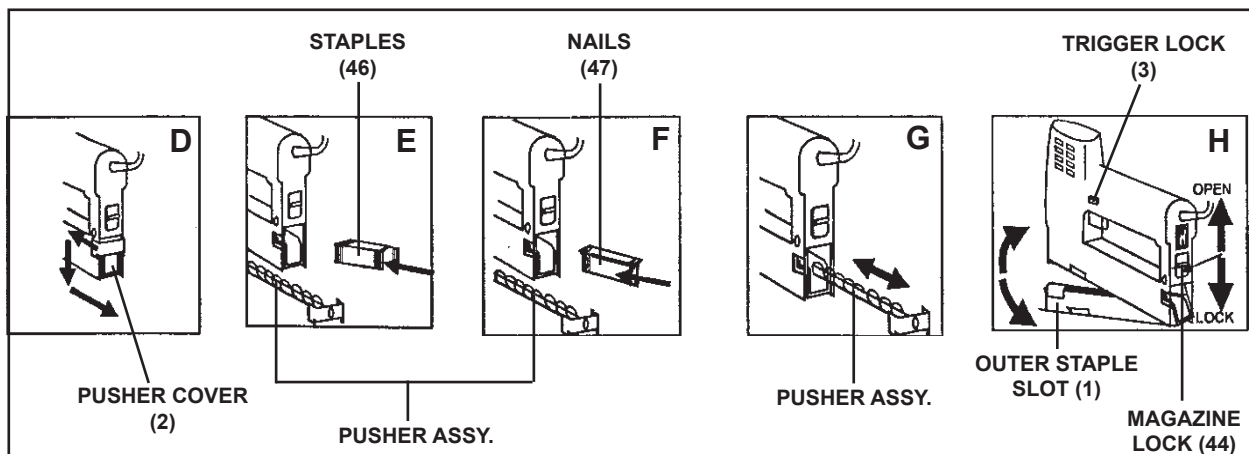

---

## OPERATION

---

**⚠ WARNING** TO PREVENT  
SERIOUS INJURY:

**Wear ANSI-approved impact safety goggles during use.**  
Other people in the work area must also wear ANSI-approved impact safety goggles.

**FIGURE I**

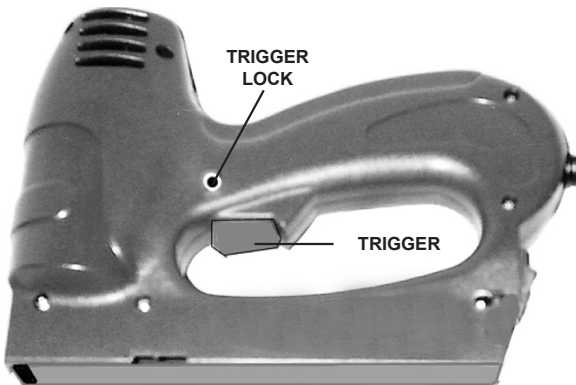

1. **Lock the Trigger by moving the Trigger Lock to the right.** Then, plug the tool's Power Cord/Plug into the nearest 120 volt, grounded, electrical outlet.
  2. Unlock the Trigger by moving the Trigger Lock to the left.
  3. To fire, firmly press the Nose of the Stapler/Nailer on the workpiece. The Stapler/Nailer should *not* fire if the Trigger is *not* squeezed. Briefly squeeze the Trigger once; one Staple/Nail will be fired.
  4. If additional force is needed, your other hand can be used.
  5. **When finished using the Stapler/Nailer, lock the Trigger by moving the Trigger Lock to the right.** Unplug the tool from its electrical outlet, and remove all unused Staples/Nails from the tool.
6. Store the Stapler/Nailer in a clean, dry, safe location out of reach of children.



## **INSPECTION, MAINTENANCE, AND CLEANING**

**⚠ WARNING!** Lock the Trigger by moving the Trigger Lock to the right and unplug the tool before performing any service, maintenance, or cleaning of the Stapler/Nailer. All maintenance, service, or repairs not mentioned in this manual must only be performed by a qualified service technician.

1. **Before each use**, inspect the general condition of the Stapler/Nailer. Check for loose screws, misalignment or binding of moving parts, cracked or broken parts, jammed Staples/Nails, damaged Power Cord/Plug, and any other condition that may affect the safe operation of the Tool. If abnormal noise or vibration occurs, have the problem corrected before further use.  
**Do not use damaged equipment.**
2. **To clean**, wipe with a damp cloth, using a mild detergent. Never use solvents such as thinner, alcohol, trichloroethylene, etc. to clean the Stapler/Nailer.
3. Always empty the Stapler/Nailer of its Staples/Nails and store the tool in a clean, dry, safe location out of reach of children and other unauthorized people.

## **Clearing Jams**

1. **Lock the Trigger by moving the Trigger Lock to the right and unplug the tool before clearing jams.**
2. Push the Magazine Lock upward to its "OPEN" position. Pull the Outer Staple Slot slightly backward before pulling it down. **(See Figure H.)**
3. Use pliers to take out the jammed Staple/Nail. Then pull the Outer Staple Slot up to its original position, and push the Magazine Lock downward to its "CLOSED" position to lock the Outer Staple Slot in place. **(See Figure H.)**

## TROUBLESHOOTING

<b>Problem</b>	<b>Possible Solution</b>
Tool will not fire Staples/Nails.	<ol style="list-style-type: none"><li>1. Unlock the Trigger by moving the Trigger Lock to the left.</li><li>2. Fully squeeze the Trigger.</li><li>3. Lock the Pusher Cover and Magazine Lock in place.</li><li>4. Load the tool with Staples or Nails.</li><li>5. Plug tool into a working, 120 volt, grounded, electrical outlet.</li><li>6. Check for and remove the tool for Staple/Nail jams.</li><li>7. Have the tool checked out by a qualified service technician.</li></ol>
Tool fires without squeezing the Trigger.	Immediately discontinue using the tool, and have the tool checked out by a qualified service technician.

---

### **PLEASE READ THE FOLLOWING CAREFULLY**

---

THE MANUFACTURER AND/OR DISTRIBUTOR HAS PROVIDED THE PARTS LIST AND ASSEMBLY DIAGRAM IN THIS MANUAL AS A REFERENCE TOOL ONLY. NEITHER THE MANUFACTURER OR DISTRIBUTOR MAKES ANY REPRESENTATION OR WARRANTY OF ANY KIND TO THE BUYER THAT HE OR SHE IS QUALIFIED TO REPLACE ANY PARTS OF THE PRODUCT. IN FACT, THE MANUFACTURER AND/OR DISTRIBUTOR EXPRESSLY STATES THAT ALL REPAIRS AND PARTS REPLACEMENTS SHOULD BE UNDERTAKEN BY CERTIFIED AND LICENSED TECHNICIANS, AND NOT BY THE BUYER. THE BUYER ASSUMES ALL RISKS AND LIABILITY ARISING OUT OF HIS OR HER REPAIRS TO THE ORIGINAL PRODUCT OR REPLACEMENT PARTS THERETO, OR ARISING OUT OF HIS OR HER INSTALLATION OF REPLACEMENT PARTS THERETO.

## PARTS LIST AND DIAGRAM

Part	Description	Qty.
1	Outer Staple Slot	1
1-1	Inner Staple Slot	1
2	Pusher Cover	1
3	Trigger Lock	1
4	Pusher Spring	1
5	Pad	1
6	Spring	1
7	Impact Plate	1
7-1	Pin	1
8	Shaft	1
9	Stopper	1
10	Trigger	1
11	Trigger Spring	1
12	Pusher	1
13	Driver Guide	1
14	Driver	1
15	Bobbin	1
16	Winding	1

Part	Description	Qty.
17-1	Right Housing	1
17-2	Right Housing	1
18	Screw	2
19	PCB	1
20	Plate-3	1
21	Screw	1
22	Power Cord/Plug	1
24	Sleeve	1
25	Strain Relief	1
26	Staple Bar	1
27	Heat Shrink Sleeve	1
32	Rivet	1
33	E-Ring	1
34	Screw	1
39	O-Ring	1
40	Staple Cover	1
44	Magazine Lock	1
45	Handle	1

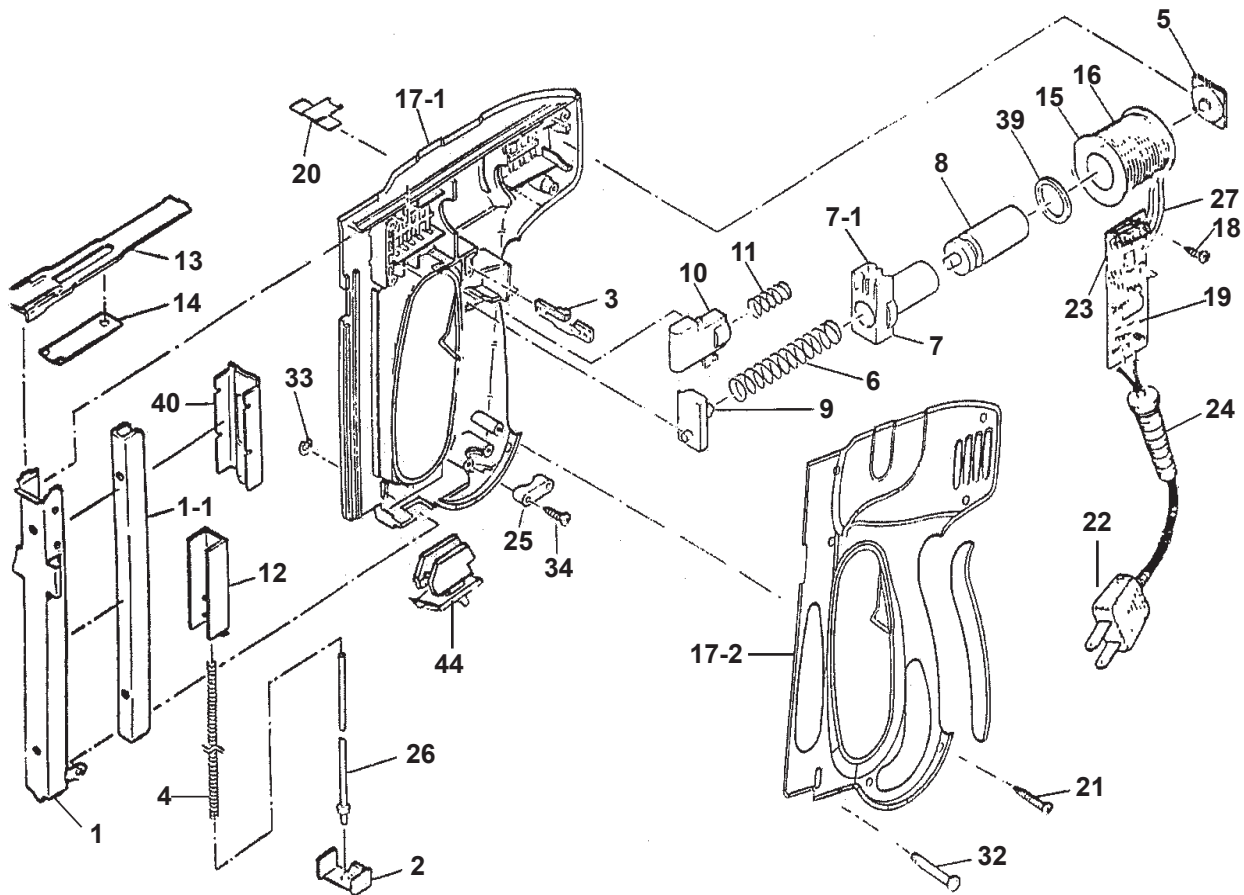

**NOTE:** Some parts are listed and shown for illustration purposes only, and are not available individually as replacement parts.

---

## LIMITED 90 DAY WARRANTY

---

Harbor Freight Tools Co. makes every effort to assure that its products meet high quality and durability standards, and warrants to the original purchaser that this product is free from defects in materials and workmanship for the period of 90 days from the date of purchase. This warranty does not apply to damage due directly or indirectly, to misuse, abuse, negligence or accidents, repairs or alterations outside our facilities, criminal activity, improper installation, normal wear and tear, or to lack of maintenance. We shall in no event be liable for death, injuries to persons or property, or for incidental, contingent, special or consequential damages arising from the use of our product. Some states do not allow the exclusion or limitation of incidental or consequential damages, so the above limitation of exclusion may not apply to you. THIS WARRANTY IS EXPRESSLY IN LIEU OF ALL OTHER WARRANTIES, EXPRESS OR IMPLIED, INCLUDING THE WARRANTIES OF MERCHANTABILITY AND FITNESS.

To take advantage of this warranty, the product or part must be returned to us with transportation charges prepaid. Proof of purchase date and an explanation of the complaint must accompany the merchandise. If our inspection verifies the defect, we will either repair or replace the product at our election or we may elect to refund the purchase price if we cannot readily and quickly provide you with a replacement. We will return repaired products at our expense, but if we determine there is no defect, or that the defect resulted from causes not within the scope of our warranty, then you must bear the cost of returning the product.

This warranty gives you specific legal rights and you may also have other rights which vary from state to state.

**3491 Mission Oaks Blvd. • PO Box 6009 • Camarillo, CA 93011 • (800) 444-3353**

## Free Manuals Download Website

<http://myh66.com>

<http://usermanuals.us>

<http://www.somanuals.com>

<http://www.4manuals.cc>

<http://www.manual-lib.com>

<http://www.404manual.com>

<http://www.luxmanual.com>

<http://aubethermostatmanual.com>

Golf course search by state

<http://golfingnear.com>

Email search by domain

<http://emailbydomain.com>

Auto manuals search

<http://auto.somanuals.com>

TV manuals search

<http://tv.somanuals.com>