

CHICAGO **welding**
ELECTRIC **systems**

STUD WELDER DENT REPAIR KIT

Model 03223

ASSEMBLY AND OPERATING INSTRUCTIONS



Distributed exclusively by
Harbor Freight Tools®.

3491 Mission Oaks Blvd., Camarillo, CA 93011
Visit our Web site at <http://www.harborfreight.com>

**TO PREVENT SERIOUS INJURY, READ AND UNDERSTAND
ALL WARNINGS AND INSTRUCTIONS BEFORE USE.**

Copyright © 2003 by Harbor Freight Tools®. All rights reserved. No portion of this manual or any artwork contained herein may be reproduced in any shape or form without the express written consent of Harbor Freight Tools.

For technical questions and replacement parts, please call 1-800-444-3353.

Cover Rev 06f, 07e

Specifications

Welding Process	Resistance Weld
Power Requirement	120 V~, 60 Hz, ~40 A Peak
Recommended Circuit	20 A (dedicated)
Switch	Pushbutton, momentary
Circuit Breaker	Pushbutton reset; Rating: 125/250 VAC, 60 Hz, 10 amp
Stud Weld Time	0.5 to 1.0 seconds
Line Cord	6 foot, 3-prong plug, UL listed
Weight	10.1 lb.
Accessories	- Bag: 100 each 2mm, 3mm, 4mm studs; steel with copper coating - 2 lb. slide hammer dent puller - One of each nozzle (2mm, 3mm, 4mm)

Save This Manual

You will need the manual for the safety warnings and precautions, assembly instructions, operating and maintenance procedures, parts list and diagram. Keep your invoice with this manual. Write the invoice number on the inside of the front cover. Keep the manual and invoice in a safe and dry place for future reference.

Safety Warnings and Precautions

WARNING: When using tool, basic safety precautions should always be followed to reduce the risk of personal injury and damage to equipment.

Read all instructions before using this tool!

1. **Keep work area clean.** Cluttered areas invite injuries.
2. **Observe work area conditions.** Do not use machines or power tools in damp or wet locations. Don't expose to rain. Keep work area well lighted. Do not use electrically powered tools in the presence of flammable gases or liquids.
3. **Keep children away.** Children must never be allowed in the work area. Do not let them handle machines, tools, or extension cords.
4. **Store idle equipment.** When not in use, tools must be stored in a dry location to inhibit rust. Always lock up tools and keep out of reach of children.
5. **Use the right tool for the job.** Do not attempt to force a small tool or attachment to do the work of a larger industrial tool. There are certain applications for which this tool was designed. It will do the job better and more safely at the rate for which it was intended. Do not modify this tool and do not use this tool for a purpose for which it was not intended.
6. **Dress properly.** Do not wear loose clothing or jewelry as they can be caught in moving parts. Protective, electrically non-conductive clothes and non-skid footwear are recommended when working. Wear restrictive hair covering to contain long hair.
7. **Do not overreach.** Keep proper footing and balance at all times. Do not reach over or across running machines.

REV 04b, 04e, 07e

8. **Use eye and ear protection.** Always wear ANSI-approved impact safety goggles. Wear a NIOSH-approved dust mask or respirator when working around metal, wood, and chemical dusts and mists.
9. **Maintain tools with care.** Keep tools sharp and clean for better and safer performance. Follow instructions for lubricating and changing accessories. Inspect tool cords periodically and, if damaged, have them repaired by a qualified technician. The handles must be kept clean, dry, and free from oil and grease at all times.
10. **Disconnect power.** Unplug tool when not in use.
11. **Remove adjusting keys and wrenches.** Check that keys and adjusting wrenches are removed from the tool or machine work surface before plugging it in.
12. **Avoid unintentional starting.** Be sure the switch is in the Off position when not in use and before plugging in. Do not carry any tool with your finger on the trigger, whether it is plugged in or not.
13. **Stay alert.** Watch what you are doing, use common sense. Do not operate any tool when you are tired.
14. **Check for damaged parts.** Before using any tool, any part that appears damaged should be carefully checked to determine that it will operate properly and perform its intended function. Check for alignment and binding of moving parts; any broken parts or mounting fixtures; and any other condition that may affect proper operation. Any part that is damaged should be properly repaired or replaced by a qualified technician. Do not use the tool if any switch does not turn On and Off properly.
15. **Guard against electric shock.** Prevent body contact with grounded surfaces such as pipes, radiators, ranges, and refrigerator enclosures.
16. **Replacement parts and accessories.** When servicing, use only identical replacement parts. Use of any other parts will void the warranty. Only use accessories intended for use with this tool. Approved accessories are available from Harbor Freight Tools.
17. **Do not operate tool if under the influence of alcohol or drugs.** Read warning labels if taking prescription medicine to determine if your judgment or reflexes are impaired while taking drugs. If there is any doubt, do not operate the tool.
18. **Use proper size and type extension cord.** If an extension cord is required, it must be of the proper size and type to supply the correct current to the tool without heating up. Otherwise, the extension cord could melt and catch fire, or cause electrical damage to the tool. This tool requires use of an extension cord with up to **20 amps** capability (up to 50 feet), with wire size rated at **10 AWG**. Longer extension cords require larger size wire. If you are using the tool outdoors, use an extension cord rated for outdoor use (signified by "WA" on the jacket).
19. **Maintenance.** For your safety, service and maintenance should be performed regularly by a qualified technician.
20. **People with pacemakers should consult their physician(s) before use.** Electromagnetic fields in close proximity to heart pacemaker could cause pacemaker interference or pacemaker failure.
21. **This Stud Welder requires the use of both hands when operating.** This helps maintain tool stability and keeps hands away from the working area of the tool.

22. **Avoid burns.** Do not touch the welded stud electrode or work surface until it cools.
23. **Avoid accidental activation.** Unplug the Stud Welder while inserting the stud electrode into the Stud Welder.
24. **Avoid electrical shock.** Do not operate the Stud Welder with its protective case removed. Do not touch grounded surfaces while operating.

Inhalation Hazard

Welding/Plasma Cutting Produces TOXIC FUMES and GASSES.



Exposure to welding or cutting gasses can increase the risk of developing certain cancers, such as cancer of the larynx and lung cancer. Also, some diseases that may be linked to exposure to welding or plasma cutting gasses or fumes are:

- Early onset of Parkinson's Disease
- Damage to the reproductive organs
- Inflammation of the small intestine or stomach
- Respiratory diseases such as emphysema, bronchitis or pneumonia
- Heart Disease
- Ulcers
- Kidney damage



Safety precautions, such as using natural or forced air ventilation and wearing an ANSI approved respirator, are **ESSENTIAL** to reduce the risk of developing the above illnesses.

Warning: The warnings, cautions, and instructions discussed in this instruction manual cannot cover all possible conditions and situations that may occur. It must be understood by the operator that common sense and caution are factors which cannot be built into this product, but must be supplied by the operator.

Note: Performance of this tool may vary depending on variations in local line voltage. Extension cord usage may also affect tool performance.

Unpacking

When unpacking, check to make sure the following parts are included.



If any parts are missing or broken, please call Harbor Freight Tools at the number on the cover of this manual as soon as possible.

Operation

Note: Before trying to pull out a dent on your vehicle, it is recommended that you first practice welding to a scrap of metal. Also practice pulling out the dent with the Slide Hammer.

1. Clean the surface down to the metal where the stud is to be welded.
2. Insert the stud into the hole of the Stud Electrode.
3. Plug the Line Cord into an electrical circuit outlet with at least a 20 amp capacity.



4. With sure footing, and both hands on the Stud Welder, push the Stud Welder toward the metal surface until the Electrode Assembly touches the metal surface.
5. While holding the Stud Welder steady, press in on the Trigger Switch momentarily from 0.5 to 1 second. Release the Trigger Switch.

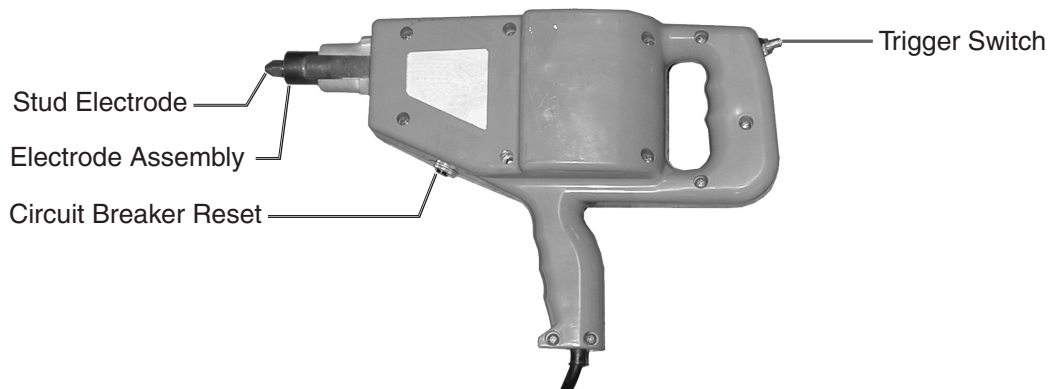

6. Pull the Stud Welder directly back, leaving the welded stud in place. There should be less than 1/4 inch discoloration around the weld.
7. Place and tighten the Slide Hammer head onto the welded stud by turning the head roller toward you to the top of its rotation and slide the tip over the stud to be pulled.
8. With one hand on the (center) handle, and the other hand on the back handle, apply a backward hammering motion to the desired pressure until the dent has popped out.

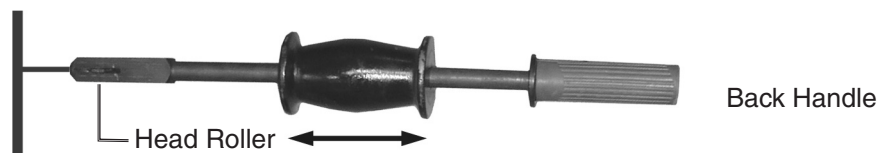

9. Disengage the Slide Hammer head from the welded stud by tapping the (center) handle forward on the head until the Stud is released.
10. Cut off stud and grind down the stud tip to the metal surface.

Troubleshooting

SYMPTOM	POSSIBLE CAUSE	SUGGESTED ACTION
Stud does not weld; Weld area cold	<ol style="list-style-type: none"> 1. No power to line cord 2. Stud Welder circuit breaker open 3. Not making contact to metal surface with Electrode Assy. 	<ol style="list-style-type: none"> 1. Check power source 2. Press Circuit Breaker Reset button 3. Press harder on the Stud Welder; Clean metal area better.
Weld time is longer than one second	<ol style="list-style-type: none"> 1. Electrode or Stud dirty 2. Weld surface not cleaned to the metal 	<ol style="list-style-type: none"> 1. Clean or replace both 2. Clean surface again
Weak weld, stud does not hold	<ol style="list-style-type: none"> 1. "On Time" not long enough 2. Electrode or Stud dirty 3. Weld surface not cleaned down to bare metal 	<ol style="list-style-type: none"> 1. Hold trigger longer 2. Clean or replace both 3. Clean surface to metal
Circuit breaker continues to trip	<ol style="list-style-type: none"> 1. Circuit rating not large enough 2. Electrical fault in Welder 	<ol style="list-style-type: none"> 1. Connect to 20 A dedicated circuit 2. Have qualified technician service welder
Weld is burning through the metal	<ol style="list-style-type: none"> 1. Weld time is too long 2. Using incorrect stud 3. Dirty electrode 	<ol style="list-style-type: none"> 1. Shorten weld time 2. Replace stud with correct size 3. Clean electrode

Maintenance

Warning: Always unplug the line cord from the electrical outlet before performing any maintenance. Repairs should only be performed by a qualified technician.

1. Periodically inspect line cord for cracks. Replace if necessary.
2. Clean the unit using a damp cloth. Never use solvents.
3. Keep the electrode assembly free of oxidation by cleaning with fine steel wool.
4. If necessary, use a fine metal file to keep the electrode flat and clean.

Parts List

Part	Description	Qty
1	Nut, Brass, 5/16-18	2
2	Insulator Sleeve	1
3	100 pcs. 2mm studs 100 pcs. 3mm studs 100 pcs. 4mm studs	3 bags
4	Slide Hammer	1
5	Washer, Split Lock, 5/16"	1
6	Terminal, Closed End	2
7	Wire Assembly, flag / spade	1
8	Wire Assembly, flag / bare	1
9	Electrode Assembly	1
10	Spring, Sliding Electrode	1
11	Sliding Electrode	1
12A	2mm electrode	1
12B	3mm electrode	1
12C	4mm electrode	1
13	Screw, hex head cap, 1/4x20x5/8"	1
14	Insulator, FRP	1
15	Circuit Breaker, 120 VAC	1
16	Screw, Roundhead, 10-32x7/8"	2
17	Trigger Boot	1
18	Trigger Switch	1
19*	Line Cord, 120 VAC	1
20	Case, Left	1
21	Nut, hex, 10-32	8
22*	Insulator, Nomex	1
23*	Transformer, 120 VAC	1
24	Screw, hex head cap, 1/4x20x3/4"	1
25	Washer, flat SAE 1/4"	4
26	Case, right	1
27	Screw, round head, 10-32x1-3/4"	6
28	Strap, Braided	1
29	Washer, Split Lock, 1/4"	2
30	Nut, hex, 1/4x20	2
31	Washer, Flat brass, 5/16"	2
32	Nut	1
33	Transformer Assembly	1

Replacement parts with asterisk are not available individually. You must purchase #33 Transformer Assembly.

* #33 Transformer Assembly only sold as a replacement assembly.

NOTE: Some parts are listed and shown for illustration purposes only and are not available individually as replacement parts.

REV 08i

SKU 3223

For technical questions, please call 1-800-444-3353.

Page 7

Assembly Drawing

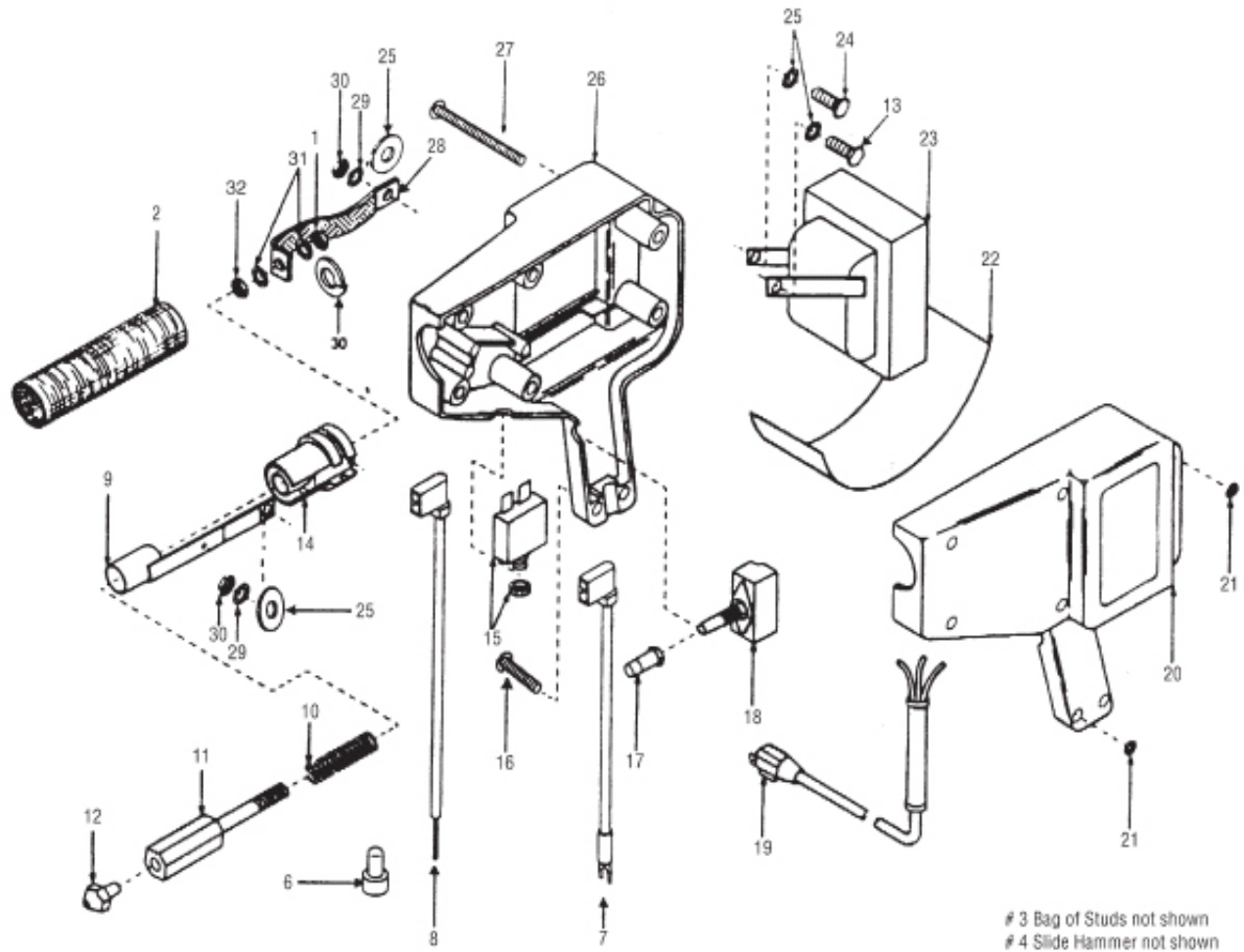

PLEASE READ THE FOLLOWING CAREFULLY

THE MANUFACTURER AND/OR DISTRIBUTOR HAS PROVIDED THE PARTS DIAGRAM IN THIS MANUAL AS A REFERENCE TOOL ONLY. NEITHER THE MANUFACTURER NOR DISTRIBUTOR MAKES ANY REPRESENTATION OR WARRANTY OF ANY KIND TO THE BUYER THAT HE OR SHE IS QUALIFIED TO MAKE ANY REPAIRS TO THE PRODUCT OR THAT HE OR SHE IS QUALIFIED TO REPLACE ANY PARTS OF THE PRODUCT. IN FACT, THE MANUFACTURER AND/OR DISTRIBUTOR EXPRESSLY STATES THAT ALL REPAIRS AND PARTS REPLACEMENTS SHOULD BE UNDERTAKEN BY CERTIFIED AND LICENSED TECHNICIANS AND NOT BY THE BUYER. THE BUYER ASSUMES ALL RISK AND LIABILITY ARISING OUT OF HIS OR HER REPAIRS TO THE ORIGINAL PRODUCT OR REPLACEMENT PARTS THERETO, OR ARISING OUT OF HIS OR HER INSTALLATION OF REPLACEMENT PARTS THERETO.

LIMITED 1 YEAR / 90 DAY WARRANTY

Harbor Freight Tools Co. makes every effort to assure that its products meet high quality and durability standards, and warrants to the original purchaser that for a period of ninety days from date of purchase that the torch, liner, wire feed mechanism (if applicable), welding clamps, electrode holders, cables and accessories packed with the welder are free of defects in materials and workmanship. **This Limited 90 Day/1 Year Warranty shall not apply to consumable parts such as tips, welding wire, and gas nozzles.** Harbor Freight Tools also warrants to the original purchaser, for a period of one year from date of purchase, that the transformer and rectifier are free from defects in materials and workmanship (90 days if used by a professional contractor or if used as rental equipment). This warranty does not apply to damage due directly or indirectly to misuse, abuse, negligence or accidents, repairs or alterations outside our facilities, normal wear and tear, or to lack of maintenance. We shall in no event be liable for death, injuries to persons or property, or for incidental, contingent, special or consequential damages arising from the use of our product. Some states do not allow the exclusion or limitation of incidental or consequential damages, so the above limitation of exclusion may not apply to you. THIS WARRANTY IS EXPRESSLY IN LIEU OF ALL OTHER WARRANTIES, EXPRESS OR IMPLIED, INCLUDING THE WARRANTIES OF MERCHANTABILITY AND FITNESS.

To take advantage of this warranty, the product or part must be returned to us with transportation charges prepaid. Proof of purchase date and an explanation of the complaint must accompany the merchandise. If our inspection verifies the defect, we will either repair or replace the product at our election or we may elect to refund the purchase price if we cannot readily and quickly provide you with a replacement. We will return repaired products at our expense, but if we determine there is no defect, or that the defect resulted from causes not within the scope of our warranty, then you must bear the cost of returning the product.

This warranty gives you specific legal rights and you may also have other rights which vary from state to state.

3491 Mission Oaks Blvd. • PO Box 6009 • Camarillo, CA 93011 • (800) 444-3353

Free Manuals Download Website

<http://myh66.com>

<http://usermanuals.us>

<http://www.somanuals.com>

<http://www.4manuals.cc>

<http://www.manual-lib.com>

<http://www.404manual.com>

<http://www.luxmanual.com>

<http://aubethermostatmanual.com>

Golf course search by state

<http://golfingnear.com>

Email search by domain

<http://emailbydomain.com>

Auto manuals search

<http://auto.somanuals.com>

TV manuals search

<http://tv.somanuals.com>