

Convection Oven Electric

ASC-2E
WITH
Mobile Stand Option 5004687



ASC-4E
WITH
Stand Option 5003489



PLATINUM SERIES

Model:

**ASC-2E
ASC-4E**

**Manual
Control**

- **INSTALLATION**
- **OPERATION**
- **MAINTENANCE**



W164 N9221 Water Street • P.O. Box 450 • Menomonee Falls, Wisconsin 53052-0450 USA
PHONE: 262.251.3800 • 800.558.8744 USA/CANADA FAX: 262.251.7067 • 800.329.8744 U.S.A. ONLY
WEBSITE: www.alto-shaam.com

ELECTRIC CONVECTION OVEN

DELIVERY

This Alto-Shaam appliance has been thoroughly tested and inspected to insure only the highest quality unit is provided. Upon receipt, check for any possible shipping damage and report it at once to the delivering carrier. *See Transportation Damage and Claims section located in this manual.*

This appliance, complete with unattached items and accessories, may have been delivered in one or more packages. Check to ensure that all standard items and options have been received with each model as ordered.

Save all the information and instructions packed with the appliance. Complete and return the warranty card to the factory as soon as possible to assure prompt service in the event of a warranty parts and labor claim.

This manual must be read and understood by all people using or installing the equipment model. Contact the Alto-Shaam service department if you have any questions concerning installation, operation, or maintenance.

NOTE: All claims for warranty must include the full model number and serial number of the unit.

UNPACKING

1. Carefully remove the appliance from the carton or crate.

NOTE: Do not discard the carton and other packaging material until you have inspected the unit for hidden damage and tested it for proper operation.

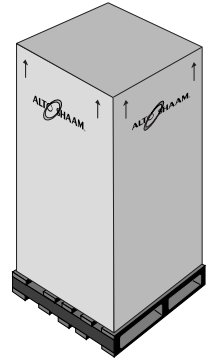

2. Read all instructions in this manual carefully before initiating the installation of this appliance.

DO NOT DISCARD THIS MANUAL.

This manual is considered to be part of the appliance and is to be provided to the owner or manager of the business or to the person responsible for training operators. *Additional manuals are available from the Alto-Shaam service department.*

3. Remove all protective plastic film, packaging materials, and accessories from the appliance before connecting electrical power. Store any accessories in a convenient place for future use.

SAFETY PROCEDURES AND PRECAUTIONS

Knowledge of proper procedures is essential to the safe operation of electrically energized equipment. In accordance with generally accepted product safety labeling guidelines for potential hazards, the following signal words and symbols may be used throughout this manual.



DANGER

Used to indicate the presence of a hazard that **will** cause severe personal injury, death, or substantial property damage if the warning included with this symbol is ignored.



WARNING

Used to indicate the presence of a hazard that **can** cause personal injury, possible death, or major property damage if the warning included with this symbol is ignored.



CAUTION

Used to indicate the presence of a hazard that can or will cause minor or moderate personal injury or property damage if the warning included with this symbol is ignored.

CAUTION

Used to indicate the presence of a hazard that can or will cause minor personal injury, property damage, or a potential unsafe practice if the warning included with this symbol is ignored.

NOTE:

Used to notify personnel of installation, operation, or maintenance information that is important but not hazard related.

1. This appliance is intended to cook, hold or process foods for the purpose of human consumption. No other use for this appliance is authorized or recommended.
2. This appliance is intended for use in commercial establishments where all operators are familiar with the purpose, limitations, and associated hazards of this appliance. Operating instructions and warnings must be read and understood by all operators and users.
3. Any troubleshooting guides, component views, and parts lists included in this manual are for general reference only and are intended for use by qualified technical personnel.
4. This manual should be considered a permanent part of this appliance. This manual and all supplied instructions, diagrams, schematics, parts lists, notices, and labels must remain with the appliance if the item is sold or moved to another location.

NOTE



For equipment delivered for use in any location regulated by the following directive:

DO NOT DISPOSE OF ELECTRICAL OR ELECTRONIC EQUIPMENT WITH OTHER MUNICIPAL WASTE.

INSTALLATION SAFETY WARNING



DANGER

IMPROPER INSTALLATION, ALTERATION, ADJUSTMENT, SERVICE OR MAINTENANCE COULD RESULT IN SEVERE INJURY, DEATH OR CAUSE PROPERTY DAMAGE.



CAUTION

METAL PARTS OF THIS EQUIPMENT BECOME EXTREMELY HOT WHEN IN OPERATION. TO AVOID BURNS, ALWAYS USE HAND PROTECTION WHEN OPERATING THIS APPLIANCE.



CAUTION

DO NOT LIFT OR MOVE THE OVEN BY USING THE DOORS OR THE DOOR HANDLES.



DANGER

DO NOT store or use any flammable liquids or allow flammable vapors in the vicinity of any appliance.

SITE INSTALLATION

This appliance must be installed in a location that will permit the oven to function for its intended purpose and to allow adequate clearance for ventilation, proper cleaning, and maintenance access.

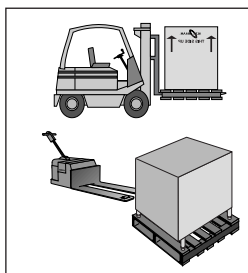

1. Hood installation is recommended. (CHECK LOCAL CODES).
2. The oven must be installed on a stable and level surface.
3. **DO NOT** install this oven in any area where it may be affected by any adverse conditions such as steam, grease, dripping water, high temperatures, etc.
4. **DO NOT** store or use any flammable liquids or allow flammable vapors in the vicinity of this oven or any other appliance.
5. This appliance must be kept free and clear of any combustible materials.
6. This appliance must be kept free and clear of any obstructions blocking access for maintenance or service.

ASC-2E • WEIGHT	
NET: 250 lb (113 kg) EST.	SHIP: 325 lb (147 kg) EST.
CRATE DIMENSIONS:	44" H x 42" W x 42" D (1118mm x 1067mm x 1067mm)
MINIMUM ENTRY CLEARANCE	31" (787mm) UNCRATED
ASC-2E • DIMENSIONS: H x W x D	
EXTERIOR: 32-1/8" x 30" x 30-1/8" (815mm x 762mm x 815mm)	
INTERIOR: 20" x 15" x 21" (508mm x 381mm x 533mm)	

ASC-4E • WEIGHT	
NET: 393 lb (178 kg) EST.	SHIP: 438 lb (199 kg)
CRATE DIMENSIONS:	40" H x 44" W x 53" D (1016mm x 1118mm x 1346mm)
MIN. ENTRY CLEARANCE	31-1/2" (800mm) UNCRATED w/O LEGS
ASC-4E • DIMENSIONS: H x W x D	
EXTERIOR: 57-1/2" x 38" x 44-1/2" (1461mm x 965mm x 1130mm)	
INTERIOR: 24" x 29-1/8" x 25" (610mm x 740mm x 635mm)	

Where automatically operated appliances are vented through a ventilating hood or exhaust system equipped with a damper or with a power means of exhaust, provisions shall be made to allow the equipment to operate only when the damper is open to a position to properly vent the appliance and when the power means of exhaust is in operation. ACCORDANCE WITH NFPA 54 COMMONWEALTH OF MASSACHUSETTS ONLY.

MINIMUM CLEARANCE REQUIREMENTS	
BACK	0" (0mm)
LEFT SIDE	2" (51mm)
RIGHT SIDE	2" (51mm)
FROM GREASE PRODUCING EQUIPMENT	6" (152mm)
RECOMMENDED SERVICE ACCESS: 20" (508mm) RIGHT SIDE	

INSTALLATION

EXTERIOR DIMENSIONS

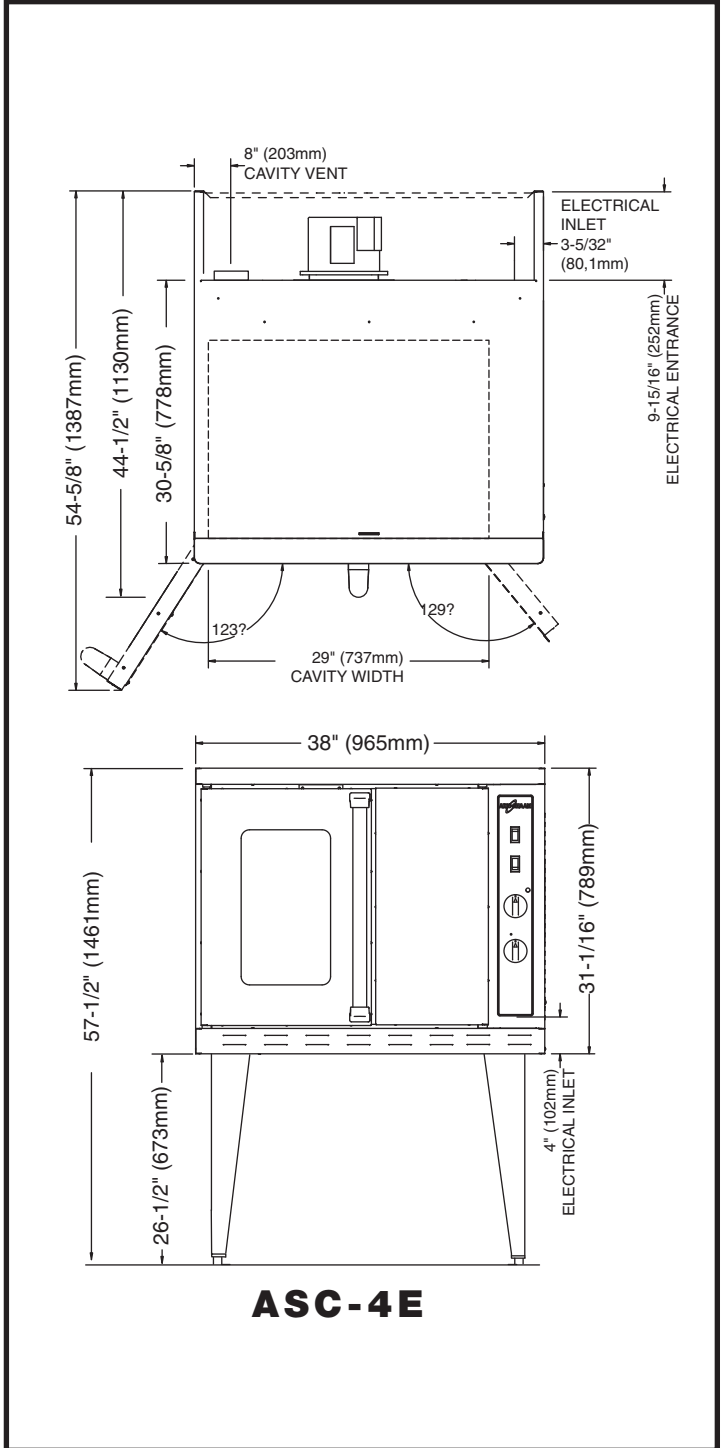
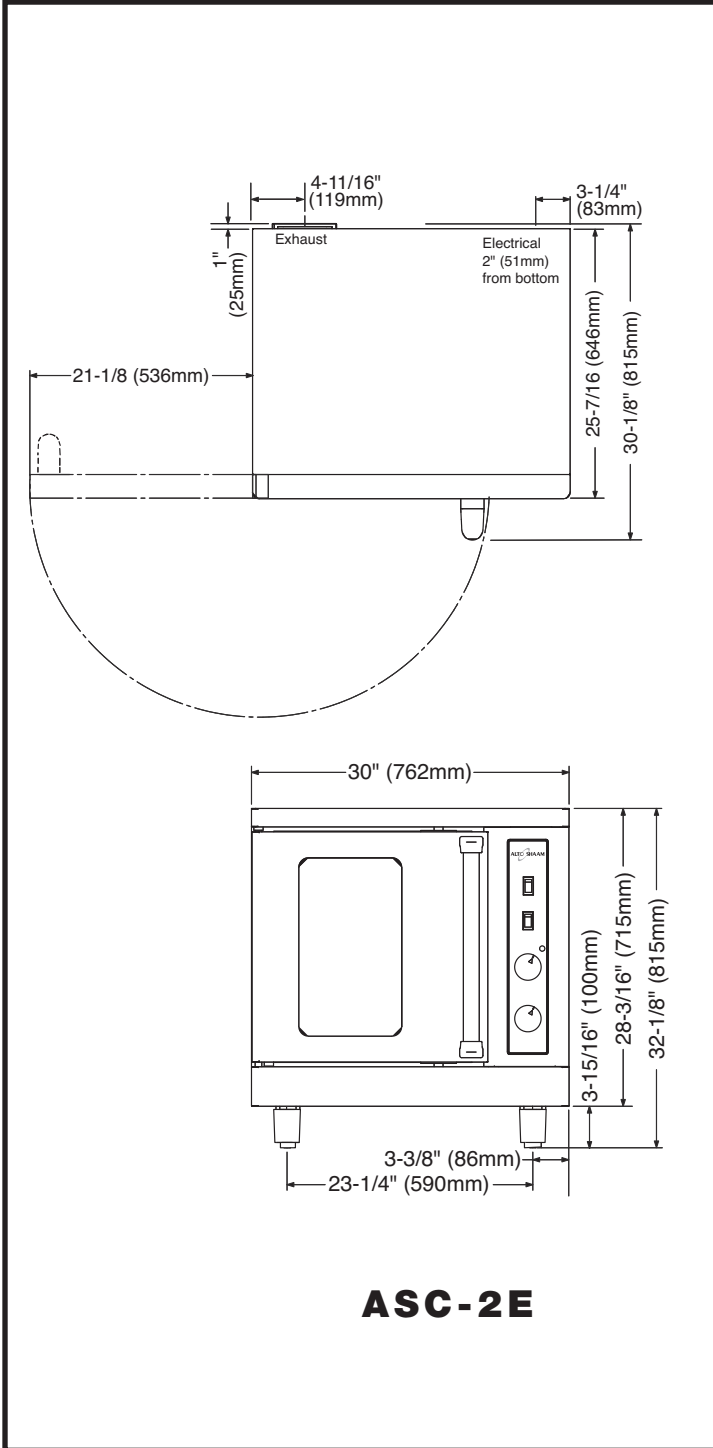

LISTED
COOKING APPLIANCE
49ZA

INSTALLATION

INSTALLATION REQUIREMENTS

A number of adjustments are associated with initial installation and start-up. It is important that these adjustments be conducted by a qualified service technician. Installation and start-up adjustments are the responsibility of the dealer or user. These adjustments include but are not limited to thermostat calibration, door adjustment, leveling, and moisture vent installation.

All clearances for proper ventilation air supply must be maintained to minimize fire hazard. Do not locate the oven immediately adjacent to any other heat generating appliance.

CAUTION

Inadequate ventilation may result in a high ambient temperature at the rear of the oven. An excessive ambient temperature can cause the thermal-overload protection device on the blower motor to trip resulting in severe damage to the blower motor.

LEVELING

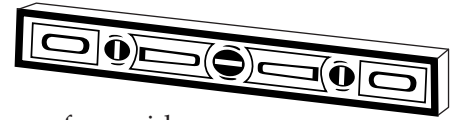

Level this appliance from side-to-side and front-to-back with the use of a spirit level. For ovens installed on a mobile stand, it is important that the installation surface be level due to the probability of frequent oven repositioning.

We recommend checking the level of the appliance periodically to make certain the floor has not shifted nor the appliance moved.

NOTE: Failure to properly level this oven can cause improper function and will result in the uneven baking of products consisting of semi-liquid batter.

COOLING FAN
FA-3568
FAN GUARD
GD-2396

MOISTURE
VENT
ON BACK OF
OVEN

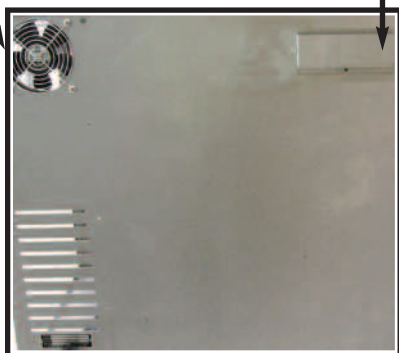

CAUTION

TO PREVENT PERSONAL INJURY,
USE CAUTION WHEN MOVING OR
LEVELING THIS APPLIANCE.

INSTALLATION

INSTALLATION REQUIREMENTS

RESTRAINT REQUIREMENTS —MOBILE EQUIPMENT

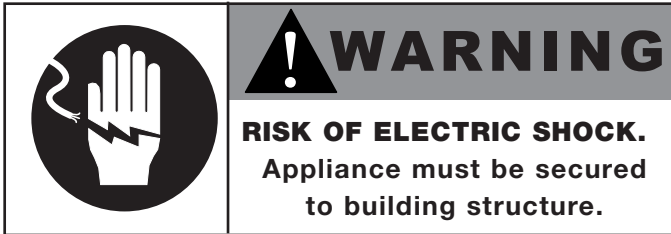

Any appliance that is not furnished with a power supply cord but includes a set of casters must be provided with a tether. Adequate means must be provided to limit the movement of this appliance without depending on or transmitting stress to the electrical conduit. The following requirements apply:

1. Casters must be a maximum height of 6" (152mm).
2. Two of the casters must of be the locking type.
3. Such mobile appliances or appliances on mobile stands must be installed with the use of a flexible connector secured to the building structure.

A mounting connector for a restraining device is located on the lower back flange of the appliance chassis or on an oven stand, approximately 18" (457mm) from the floor. A flexible connector is not supplied or available from the factory.

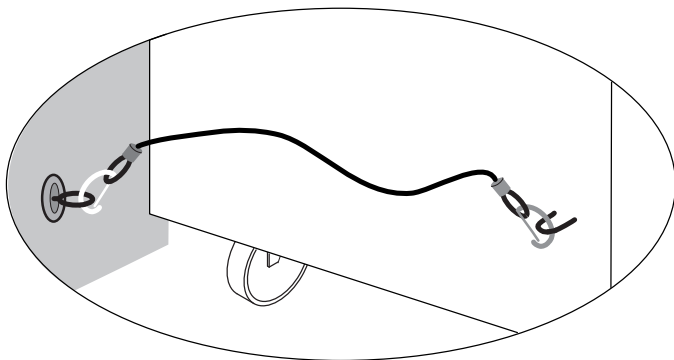

INSTALLATION

ELECTRICAL CONNECTION



! DANGER

ELECTRICAL CONNECTIONS MUST BE MADE BY A QUALIFIED SERVICE TECHNICIAN IN ACCORDANCE WITH APPLICABLE ELECTRICAL CODES.



! DANGER

ENSURE POWER SOURCE MATCHES VOLTAGE STAMPED ON APPLIANCE NAMEPLATE

The oven must be installed by a qualified electrician. This appliance must be branch circuit protected with proper ampacities, in accordance with the wiring diagram located in this manual or in the electrical compartment of the oven. The oven must be properly grounded in accordance with the National Electrical Code and applicable local codes.

Wire size for the main incoming power to the unit must match the minimum size listed in the specifications applicable to the specific oven model. For supply connections, locate the wire size posted on the label located near the electric terminal block behind the service panel or elsewhere listed in this manual. Before attempting the electrical connection, the rating plate should be checked to ensure that the electrical characteristics of the appliance and the electrical supply characteristics agree.



! DANGER

To avoid electrical shock, this appliance **MUST** be adequately grounded in accordance with local electrical codes or, in the absence of local codes, with the current edition of the National Electrical Code ANSI/NFPA No. 70. In Canada, all electrical connections are to be made in accordance with CSA C22.1, Canadian Electrical Code Part 1 or local codes.

Installation of the wiring must be made in accordance with U.L. 197 Commercial Electric Cooking Appliance Standards, Local and/or National Electrical Code, ANSI /NFPA 70-1990.

Plug the unit into a properly grounded receptacle **ONLY**, positioning the unit so that the plug is easily accessible in case of an emergency. Arcing will occur when connecting or disconnecting the unit unless all controls are in the "off" position.

Service line entry is made through the rear of the oven for connection to the terminal block. Remove the service panel on the right side of the oven for access to the terminal block.

Proper receptacle or outlet configuration or permanent wiring for this unit must be installed by a licensed electrician in accordance with applicable local electrical codes.

The oven is wired at the factory for either single phase or three phase service as indicated on the original purchase order. Input voltage and phase must match the voltage and phase of the oven. Visually check all electrical connections.

ELECTRICAL • ACS-2E					
VOLTAGE	PHASE	CYCLE/ HZ	AWG	AMPS	kW
208	1	50/60	10	25.5	5.3
240	1	50/60	10	22.0	5.3
208	3	50/60	12	14.7	5.3
240	3	50/60	12	12.8	5.3
NO CORD AND PLUG					

ELECTRICAL • ASC-4E					
VOLTAGE	PHASE	CYCLE/ HZ	AWG	AMPS	kW
208	1	50/60	6	50.0	10.4
240	1	50/60	6	43.3	10.4
208	3	50/60	8	25.0	10.4
240	3	50/60	8	25.0	10.4
NO CORD AND PLUG					

INSTALLATION

STACKING & VENTING ASSEMBLY for 2-ASC-2E/STK

SCREW SC-2351 QTY2
IN THIS LOCATION ON
BOTTOM UNIT.

REMOVE KNOCKOUT PRIOR
TO STACKING TOGETHER.
BOLT UP AND INTO
TOP UNIT

ADD
1006412
VENT RISER

SCREW SC-26520 QTY 5

REMOVE EXISTING VENT

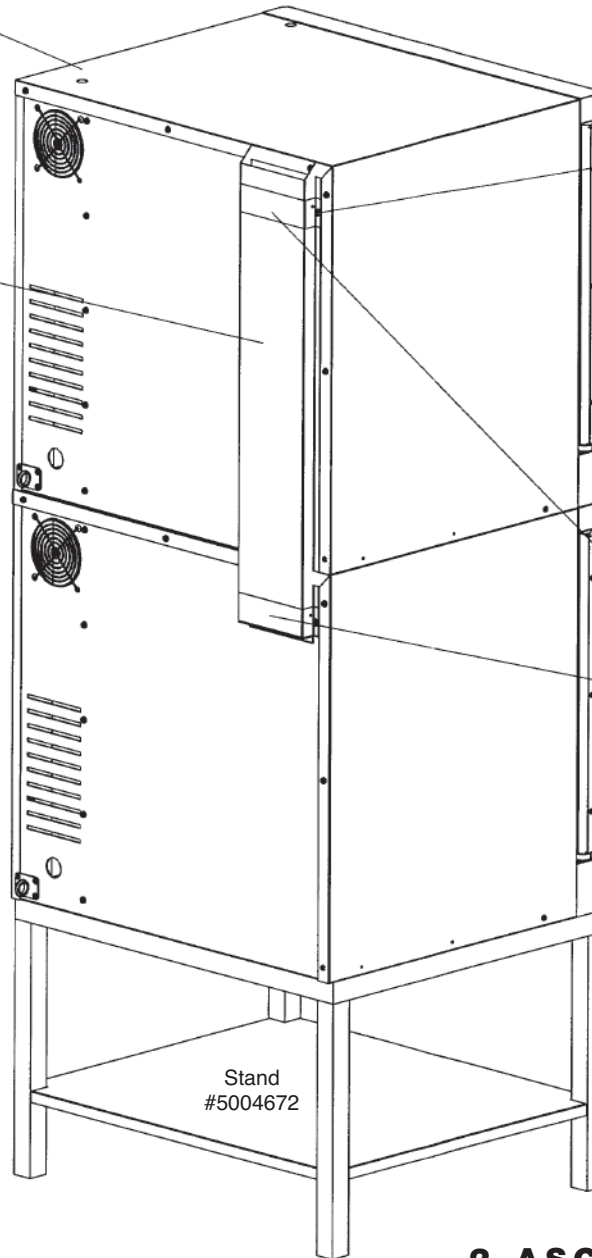

2-ASC-2E/STK

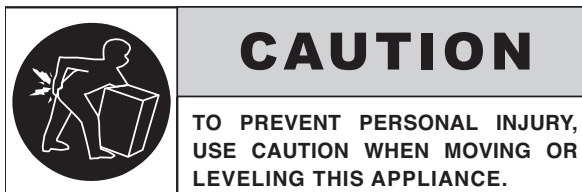

INSTALLATION

STACKING & VENTING ASSEMBLY for 2-ASC-4E/STK

Item No.	Part No.	Description	Qty.
2	1004984	RISER, FLUE ELECTRIC	1
3	SC-26520	SCREW, #10 SMS .5LG	5

After legs or casters have been installed on the bottom oven, place the upper oven on top of lower unit. Align.

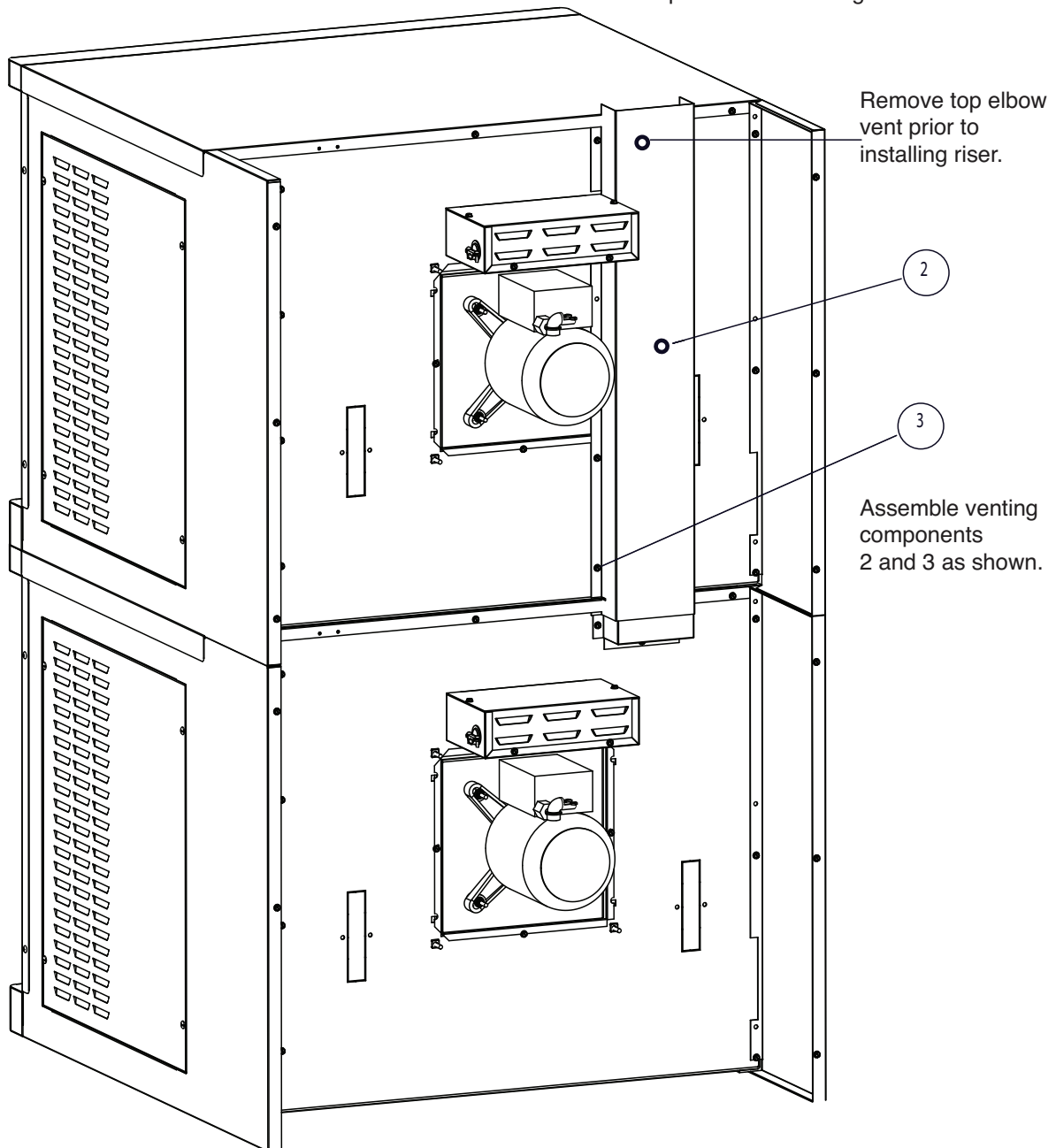

2-ASC-4E/STK



CAUTION

TO PREVENT PERSONAL INJURY,
USE CAUTION WHEN MOVING OR
LEVELING THIS APPLIANCE.

INSTALLATION

OVEN STAND ASSEMBLY - ASC-4E

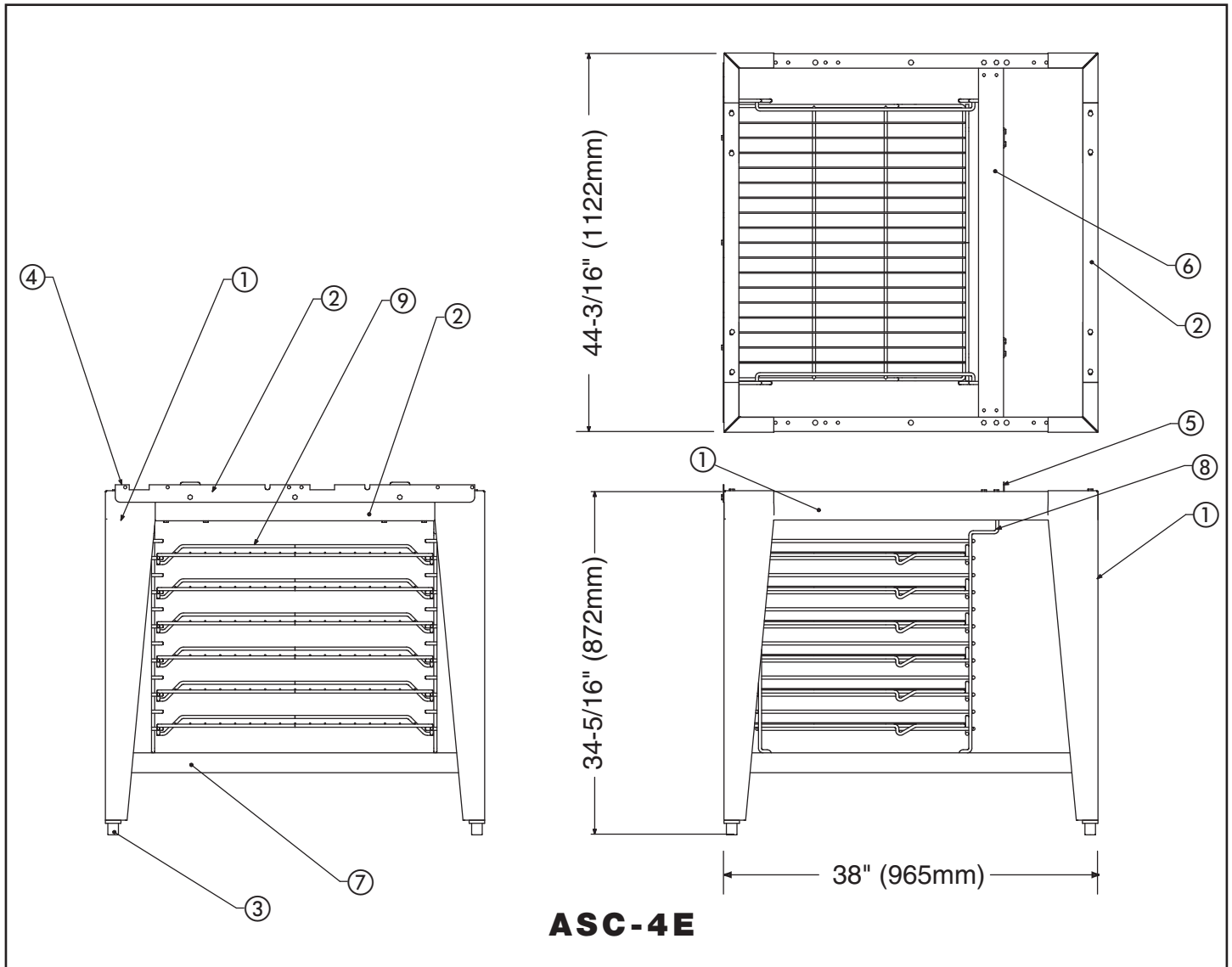

ASC-4E

ITEM NO	PART NUMBER	DESCRIPTION	QTY.
1	5003488	Leg Support Assembly	2
2	1004459	Channel, Support	2
3	LG-22185	Leg	4
	CS-25474	Casters, rigid	2
	CS-25674	Casters, swivel w/brake	2
4	1004461	Bracket, Stand	1
5	1004369	Bracket, Attachment	2
6	1004460	Channel, Back	1
7	1004466	Shelf, Stand	1
8	SR-26551	Rack, Oven Support	2
9	SH-26395	Oven Rack	6
10	SC-22729	Screws, 1/4-20 x 1/2 Hex Head	27
11	NU-23984	Net, 1/4-20 Nylon Insert, 18-8 S/S	27
12	WS-2294	Washer	27

OPERATING INSTRUCTIONS

USER SAFETY INFORMATION

START-UP OPERATION

This appliance is intended for use in commercial establishments by qualified operating personnel where all operators are familiar with the purpose, limitations, and associated hazards of this appliance. Operating instructions and warnings must be read and understood by all operators and users.

BEFORE INITIAL USE:

Interior oven surfaces must be heated to remove surface oils and the accompanying odor produced during the first use of the oven.

1. Wipe all wire shelves, side racks and the full oven interior with a clean, damp cloth.

2. Close the oven doors, press the power switch to the ON position, and set the thermostat to 300°F (149°C).
3. Allow the oven to cycle for approximately 2 hours or until no odor is detected.

PREHEATING:

Always preheat a cold oven for a minimum of 20 minutes before cooking product. Follow the operating instructions indicated on the next few pages of this manual.

OPTIONS & ACCESSORIES • ASC-2E	
LEG KIT, 4" (102mm)	
<input type="checkbox"/> Seismic feet	5004688
LEG KIT	
<input type="checkbox"/> with Bullet feet, 19-1/2" (495mm) HEIGHT	5005169
<input type="checkbox"/> with Seismic feet, 19-1/2" (495mm) HEIGHT	5005168
<input type="checkbox"/> with Casters, 23" (584mm) HEIGHT	5005181
<input type="checkbox"/> SHELF, OVEN RACK	SH-26894
STACKING HARDWARE	
SEE INDIVIDUAL STACKING COMBINATION SPECIFICATION SHEETS	
STAND, SINGLE OVEN	
<input type="checkbox"/> with Bullet feet, 26-1/2" (673mm) HEIGHT	5004672
<input type="checkbox"/> with Seismic feet, 26-1/2" (673mm) HEIGHT	5005172
<input type="checkbox"/> with Casters, 30" (762mm) HEIGHT	5004687
OPTIONS & ACCESSORIES • ASC-4E	
<input type="checkbox"/> CASTER SET, 6" (152mm)	5003790
<input type="checkbox"/> COOLING RACK FOR OVEN STAND	5003791
LEG SET (4)	
<input type="checkbox"/> 6" (152mm) with Bullet Feet	5003794
<input type="checkbox"/> 6" (6152mm) with Seismic Feet	5003795
<input type="checkbox"/> 25" (635mm) with Seismic Feet	5003785
<input type="checkbox"/> PANEL FOR BACK, Stainless Steel	5005876
SHELF, OVEN RACK	
<input type="checkbox"/> INTERCHANGEABLE WITH COOLING RACK	SH-26795
STACKING HARDWARE	
SEE INDIVIDUAL STACKING COMBINATION SPECIFICATION SHEETS	
STAND, STAINLESS STEEL	
<input type="checkbox"/> Mobile, with Cooling Racks & Casters, 38" H (965mm)	5003786
<input type="checkbox"/> Stationary, with Cooling Racks & Bullet Feet	5003489
<input type="checkbox"/> Stationary, with Cooling Racks & Seismic Feet	5003787
34-1/4" (870mm) min. • 35-1/2" (902mm) max. H (FEET ARE ADJUSTABLE)	

IN THE EVENT OF A POWER FAILURE:

- TURN ALL SWITCHES OFF.
- WAIT UNTIL POWER IS RESTORED BEFORE ATTEMPTING TO OPERATE THE OVEN.

NOTE: *If such an event has occurred, it is strongly recommended that you ensure the food in the oven is safe for consumption according to local health regulations.*

ASC-2E • PRODUCT\PAN CAPACITY

27 lb (12 kg) MAXIMUM — 17 qts (15 liters)

Nine (9): 18" x 13" x 1" HALF-SIZE SHEET PANS

5 chrome plated wire shelves with 2 removable side racks and 9 shelf positions spaced at 1-5/8" (41mm) ea.

ASC-4E • PRODUCT\PAN CAPACITY

72 lb (33 kg) MAXIMUM — 45 qts (43 liters)

Twelve (12): 18" x 26" x 1" FULL-SIZE SHEET PANS

6 chrome plated wire shelves with 2 removable side racks and 12 shelf positions spaced at 1-3/4" (43mm) ea.

OPERATING INSTRUCTIONS

USER INFORMATION

PAN/SHELF POSITIONS FOR ASC-2E:

The oven includes 5 chrome plated wire shelves with two removable side racks and 9 shelf positions spaced at 1-5/8" (41mm).

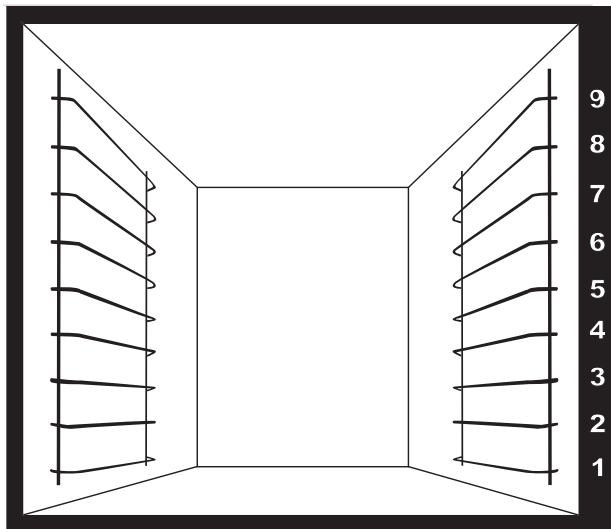

1. POSITION 2, 4, 6, 8: The best arrangement for broiling, baking cookies and for other baked goods under 2-1/2" (65mm) in height. This arrangement can also be used as the maximum capacity for reconstituting frozen entrées.
2. POSITION 1, 4, 7: General baking with the use of sheet pans for products under 3-1/2" (89mm) in height. Products include cakes, pies, muffins, or extended dishes in 12" x 20" x 2-1/2" deep pans (530mm x 325mm x 65mm GN 1/1).
3. POSITION 1, 5: Ideal positions for baking bread, meringue, or extended dishes and roasts in pans not to exceed 5-1/2" (140mm) in height.
4. POSITION 1, 6: Arrangement necessary for roasting whole turkey or roasts up to 7" (178mm) in height.

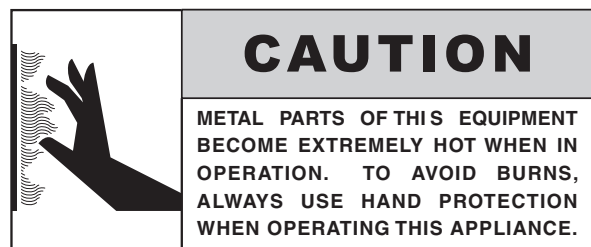

PAN/SHELF POSITIONS FOR ASC-4E:

The oven includes 6 chrome plated wire shelves with two removable side racks and 12 shelf positions spaced at 1-3/4" (43mm).

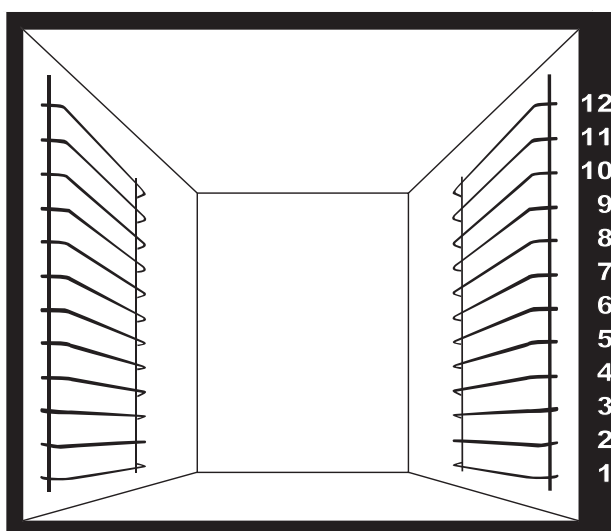

1. POSITION 2, 4, 6, 8, 10, 12: The best arrangement for broiling, baking cookies and for other baked goods under 2-1/2" (65mm) in height. This arrangement can also be used as the maximum capacity for reconstituting frozen entrées.
2. POSITION 1, 4, 7, 10: General baking with the use of sheet pans for products under 3-1/2" (89mm) in height. Products include cakes, pies, muffins, or extended dishes in 12" x 20" x 2-1/2" deep pans (530mm x 325mm x 65mm GN 1/1).
3. POSITION 1, 5, 9: Ideal positions for baking bread, meringue, or extended dishes and roasts in pans not to exceed 5-1/2" (140mm) in height.
4. POSITION 1, 6: Arrangement necessary for roasting whole turkey or roasts up to 7" (178mm) in height.

OPERATING INSTRUCTIONS

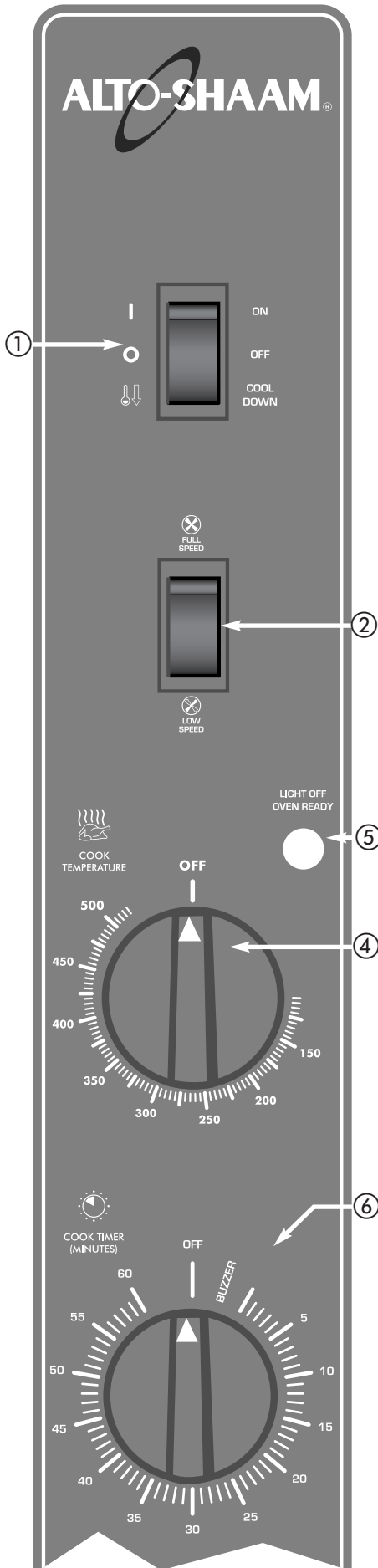

MANUAL CONTROL OPERATION

1. Press POWER SWITCH **1** to the *ON* position.
2. Press FAN SWITCH **2** to *high* or *low* fan speed.
3. Set COOK TEMPERATURE THERMOSTAT **4** to the temperature desired.

When this temperature is reached, LIGHT OFF\OVEN READY indicator light **5** will go out.

ALLOW A MINIMUM OF 20 MINUTES TO PREHEAT A COLD OVEN.

4. Load product into the oven.

For best results, always load the oven from the bottom to the top position and load as quickly as possible to retain maximum oven compartment heat.

5. Set COOK TIMER **6** by rotating the knob clockwise past the time required and then back to the desired time.

The timer will begin to count down. When the timer reaches zero, the oven will produce an audible alert signal that will continue for three minutes or until the timer knob is turned counterclockwise to the *OFF* position.

COOL-DOWN MODE

1. Press POWER SWITCH **1** to the *COOL DOWN* position.
2. Open the oven doors.

SHUT-DOWN PROCEDURE

1. Press POWER SWITCH **1** to the *OFF* position.

CHEF OPERATING TIPS



The Alto-Shaam convection oven will provide the best results and longest possible service with the utilization of the following suggestions and guidelines.

NOTE: Moisture will escape around the doors when baking products with a heavy moisture content such as chicken, potatoes, etc. This is a normal operating condition.

1. Preheat a cold oven for a minimum of 20 minutes before use.
2. As a general rule, the cooking temperature can be set lower than the temperature used in a conventional oven. Cooking time may also be shorter. It is suggested the first batch of each product prepared be monitored closely to check for variances.
3. Maintain a record of the temperatures, times, and load capacities established for products cooked on a regular basis since they will be the same or similar for succeeding loads.
4. When practical, start cooking the lowest temperature products first and gradually work up to products with a higher cooking temperature.
5. If the cooking temperature setting for the previous product is more than 10°F (5°C to 6°C) higher than the temperature needed for the next load, use the COOL-DOWN feature to decrease the oven temperature before setting the oven to a lower temperature.
6. Work as quickly as possible when loading the oven to prevent heat loss.
7. When the audible signal indicates the time has expired, remove the product from the oven as quickly as possible to avoid over-cooking.
8. Pans should be centered between side racks and each shelf should be loaded evenly to allow proper air circulation within the oven compartment.
9. To assure even cooking when baking, weigh or measure the product in each pan.
10. **ASC-2E:**
When cooking five pans of product, start from the bottom of the oven and use side rack positions 1, 3, 5, 7, and 9.

ASC-4E:
When cooking six pans of product, start from the bottom of the oven and use side rack positions 2, 4, 6, 8, 10, and 12.
11. Do not overload the oven. Refer to product/pan capacities indicated in this manual.
12. To obtain the most evenly baked product, muffin pans should be placed in the oven with the short side of each pan facing the front of the oven.
13. When rethermalizing frozen casseroles, preheat the oven 100°F (38°C) over the suggested temperature to compensate for the introduction of a large quantity of frozen product into the oven compartment. Reset the thermostat to the correct cooking temperature after the oven is loaded.
14. Use a pan extender or two inch (51mm) deep, 18" x 26" pans for batter-type products that weigh more than 8 pounds (3 to 4 kg), i.e.; pineapple upside-down cake.
15. To avoid obstructing airflow that would result in uneven cooking results, never place anything directly on the bottom of the oven cavity.

AT THE END OF THE DAY, UTILIZE THE COOL-DOWN MODE. SHUT OFF POWER ON THE COOLED OVEN BEFORE LEAVING.

Cooking Guidelines

Food	F° Temperature	Minutes /Time
Cakes, Sheet	325°	25
Chicken pieces 30 breasts & thighs, 25 legs & wings	400°	25
Chicken halves	400°	40
Beef patties	400°	8
Bacon	350°	16
Fish, frozen (5 oz.)	350°	15
Macaroni & Cheese, frozen, 1 pan	350°	50
Macaroni & Cheese, frozen, full oven	350°	90
Macaroni & Cheese, refrigerated	350°	30
Muffins	325°	13-15
Pies, Frozen	325°	40
Pizzas, Individual	325°	15
Potatoes, Baked	350°	50
Sandwiches, Grilled Cheese	400°	4-6
Tater tots	450°	10

Do not place anything directly on the bottom of the oven cavity.

CLEANING AND PREVENTIVE MAINTENANCE

PROTECTING STAINLESS STEEL SURFACES



It is important to guard against corrosion in the care of stainless steel surfaces. Harsh, corrosive, or inappropriate chemicals can completely destroy the protective surface layer of stainless steel. Abrasive pads, steel wool, or metal implements will abrade surfaces causing damage to this protective coating and will eventually result in areas of corrosion. Even water, particularly hard water that contains high to moderate concentrations of chloride, will cause oxidation and pitting that result in rust and corrosion. In addition, many acidic foods spilled and left to remain on metal surfaces are contributing factors that will corrode surfaces.

Proper cleaning agents, materials, and methods are vital to maintaining the appearance and life of this appliance. Spilled foods should be removed and the area wiped as soon as possible but at the very least, a minimum of once a day. Always thoroughly rinse surfaces after using a cleaning agent and wipe standing water as quickly as possible after rinsing.

CLEANING AGENTS

Use non-abrasive cleaning products designed for use on stainless steel surfaces. Cleaning agents must be chloride-free compounds and must not contain quaternary salts. Never use hydrochloric acid (muriatic acid) on stainless steel surfaces. Always use the proper cleaning agent at the manufacturer's recommended strength. Contact your local cleaning supplier for product recommendations.

CLEANING MATERIALS

The cleaning function can usually be accomplished with the proper cleaning agent and a soft, clean cloth. When more aggressive methods must be employed, use a non-abrasive scouring pad on difficult areas and make certain to scrub with the visible grain of surface metal to avoid surface scratches. Never use wire brushes, metal scouring pads, or scrapers to remove food residue.

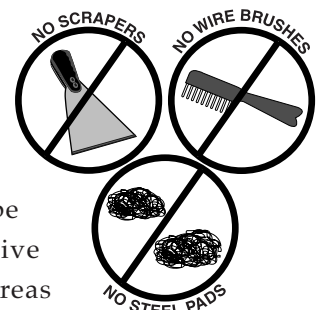

	<p>! CAUTION</p> <p>TO PROTECT STAINLESS STEEL SURFACES, COMPLETELY AVOID THE USE OF ABRASIVE CLEANING COMPOUNDS, CHLORIDE BASED CLEANERS, OR CLEANERS CONTAINING QUATERNARY SALTS. NEVER USE HYDROCHLORIC ACID (MURIATIC ACID) ON STAINLESS STEEL. NEVER USE WIRE BRUSHES, METAL SCOURING PADS OR SCRAPERS.</p>
---	--

CLEANING AND PREVENTIVE MAINTENANCE



DANGER

DISCONNECT UNIT FROM
POWER SOURCE BEFORE
CLEANING OR SERVICING.

The oven is fabricated with an easy to clean porcelain enamel interior or an optional stainless steel interior.

NOTE: Always allow the oven to cool before cleaning. If the oven is hot, allow the interior surfaces to become cool to the touch by using the cool-down mode and opening the oven door(s).



DANGER

AT NO TIME SHOULD THE OVEN INTERIOR OR EXTERIOR BE STEAM CLEANED, HOSED DOWN, OR FLOODED WITH ANY TYPE OF LIQUID. DO NOT USE A WATER JET TO CLEAN. **SEVERE DAMAGE OR ELECTRICAL HAZARD COULD RESULT. SUCH METHODS WILL ALSO VOID ANY WARRANTY CLAIMS.**

NOTE: DO NOT USE ABRASIVE CLEANING COMPOUNDS. Completely avoid the use of abrasive cleaning compounds, chloride-based cleaners, or cleaners containing quaternary salts. To protect metal finish on stainless steel, never use hydrochloric acid (muriatic acid).

CLEAN THE OVEN ON A DAILY BASIS.

1. After the oven has cooled, remove all detachable items such as wire shelves, side racks, and any drip pan. Clean these items separately.
2. Remove any food scraps from shelves, shelf supports, and blower fan wheel. Convection baffle openings must be kept clear of food scraps and grease.
3. Wipe the interior metal surfaces of the oven with a paper towel to remove any remaining food debris.
4. Clean interior with a damp cloth or sponge and any good commercial detergent at the recommended strength.
5. For baked-on food deposits, use a non-caustic and non-toxic commercial oven cleaner appropriate for the interior oven surface of the oven. Follow the product manufacturer's instructions carefully for the use of this product. Any commercial oven cleaner must be approved for use on food contact areas. Remove soil with the use of a plastic scouring pad.
6. Wipe door gaskets, control panel, door vents, and door handle thoroughly since these areas harbor food debris and grease.
7. Rinse surfaces by wiping with a clean cloth or sponge and clean warm water.

6. Wipe door gaskets, control panel, door vents, and door handle thoroughly since these areas harbor food debris and grease.



7. Rinse surfaces by wiping with a clean cloth or sponge and clean warm water.
8. Remove excess water with a sponge and wipe dry with a clean cloth or air dry. Leave doors open until interior is completely dry. Replace side racks and shelves.

Always follow appropriate state or local health (hygiene) regulations regarding all applicable cleaning and sanitation requirements for food service equipment.

AT THE END OF THE DAY, UTILIZE THE COOL-DOWN MODE. SHUT OFF POWER ON THE COOLED OVEN BEFORE LEAVING.

CLEANING AND PREVENTIVE MAINTENANCE

EXTERIOR:

To help maintain the protective film coating on polished stainless steel, clean the exterior of the cabinet with a cleaner recommended for stainless steel surfaces. Spray the cleaning agent on a clean cloth and wipe with the grain of the stainless steel.

Wipe control panel, door vents and door handles, thoroughly since these areas harbor food debris.

Clean exterior glass surfaces with a commercial window cleaner.

DO NOT USE ABRASIVE CLEANING COMPOUNDS.

MOTOR CARE

The convection oven motor contains self-lubricating, sealed ball bearings and is generally maintenance-free. During operation, the interior of the motor is cooled by air flowing into the rear of the motor case. This is a general operating feature when proper clearances have been allowed.

AT THE END OF THE DAY, UTILIZE THE COOL-DOWN MODE. SHUT OFF POWER ON THE COOLED OVEN BEFORE LEAVING.

TROUBLESHOOTING GUIDE

Oven has no power.	Check to ensure oven is connected to proper power source. Check that breaker is turned on. Fuses are blown.
Oven has power but will not turn ON .	Ensure power switch is turned on. Ensure hi limit is not tripped. Ensure doors are closed. Ensure timer is turned on. Ensure fan switch is turned on. Door switch is bad or out of adjustment.
Oven fan turns ON , but there is no heat.	Ensure thermostat is turned on. Ensure hi-limit is not tripped.
Oven heats, fan runs, but doesn't shut OFF when door is opened.	Door switch is bad or out of adjustment.



SERVICE - ASC-2E

⚠ DANGER

Service must be in accordance with all local codes and must be performed by a qualified service technician.

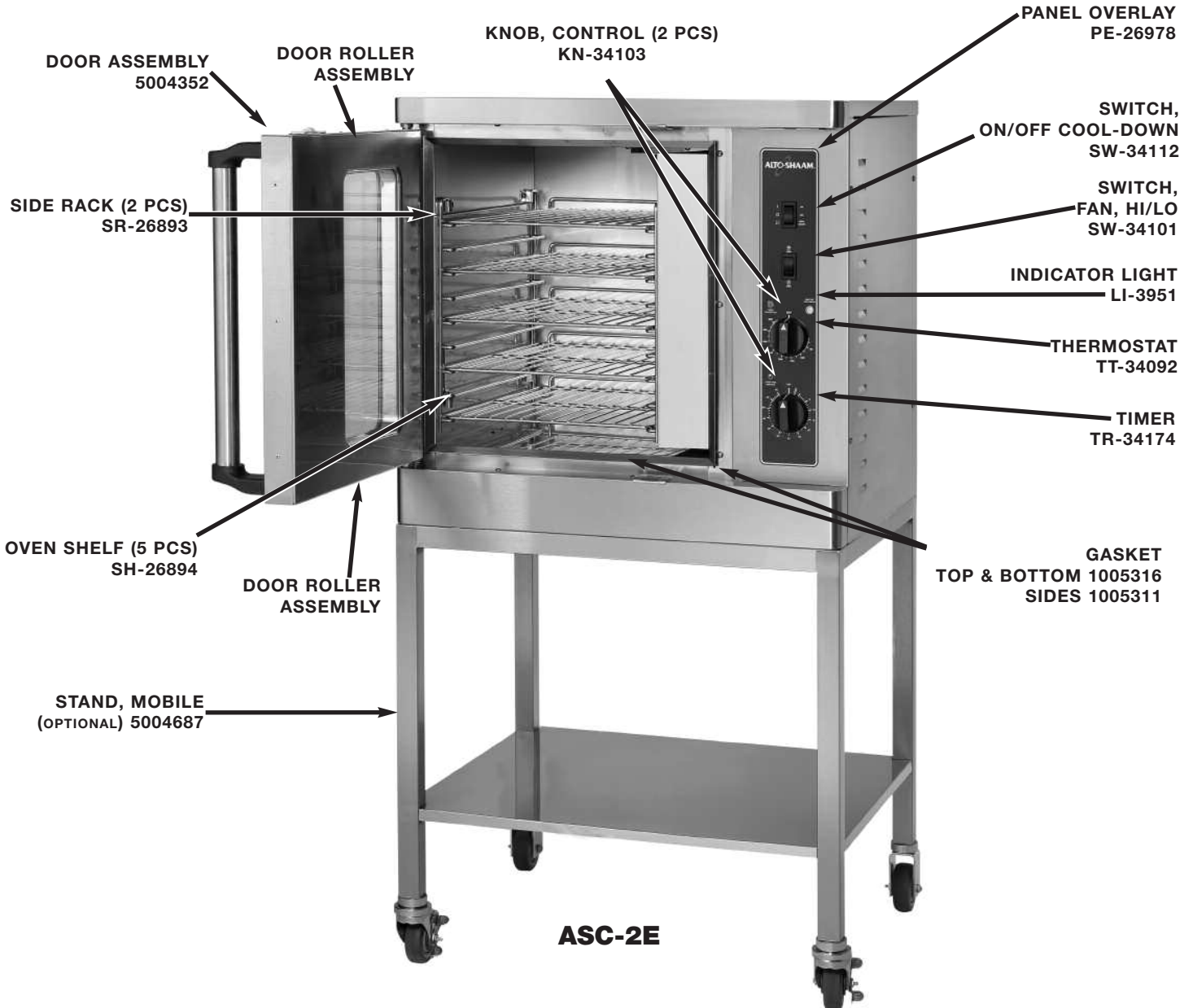

⚠ DANGER

DISCONNECT UNIT FROM POWER SOURCE BEFORE CLEANING OR SERVICING.

SERVICE -ASC-2E

INTERIOR OVEN COMPARTMENT

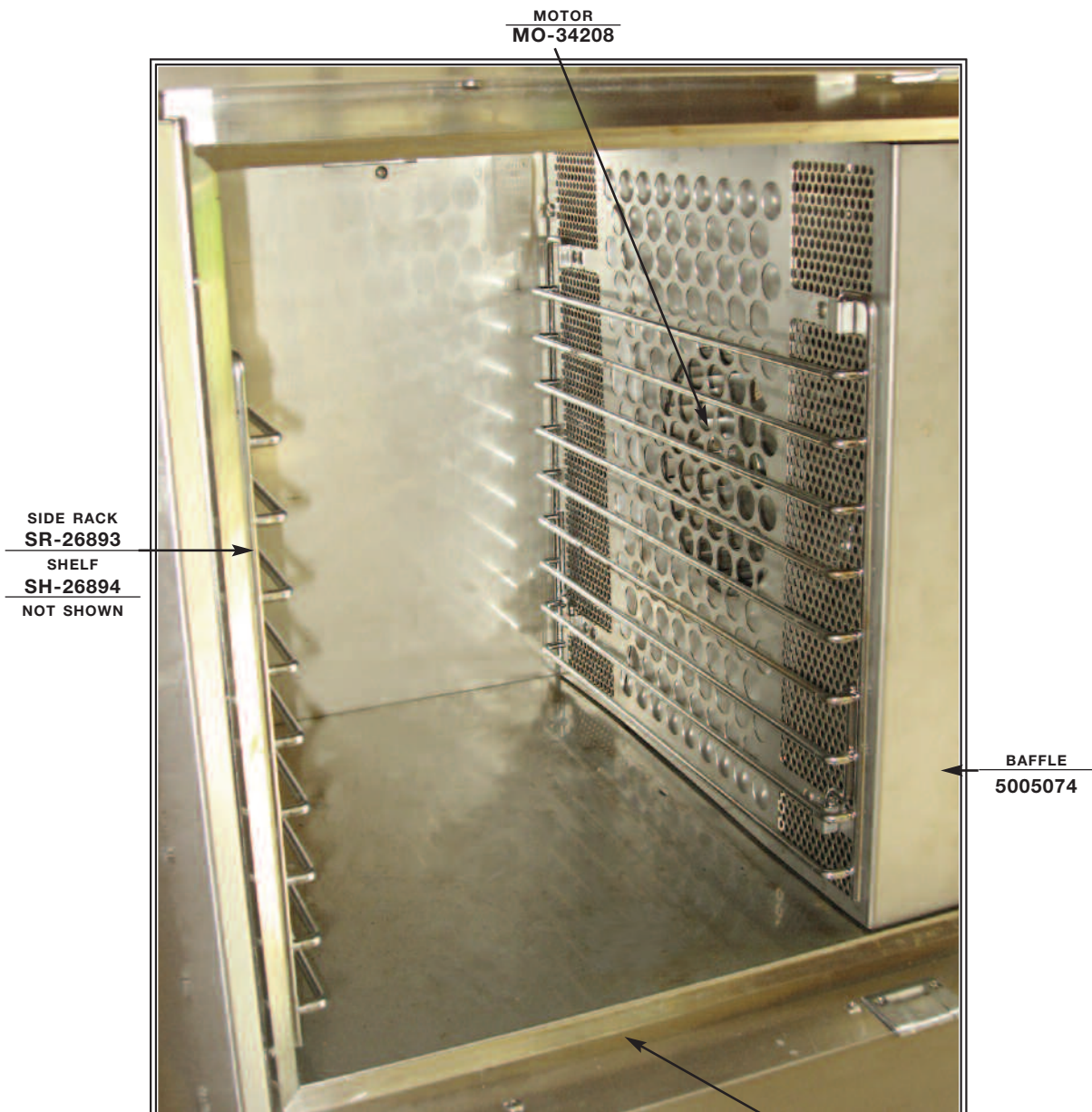

ASC-2E
oven interior

SERVICE -ASC-2E

RIGHT SIDE SERVICE PANEL - REMOVED

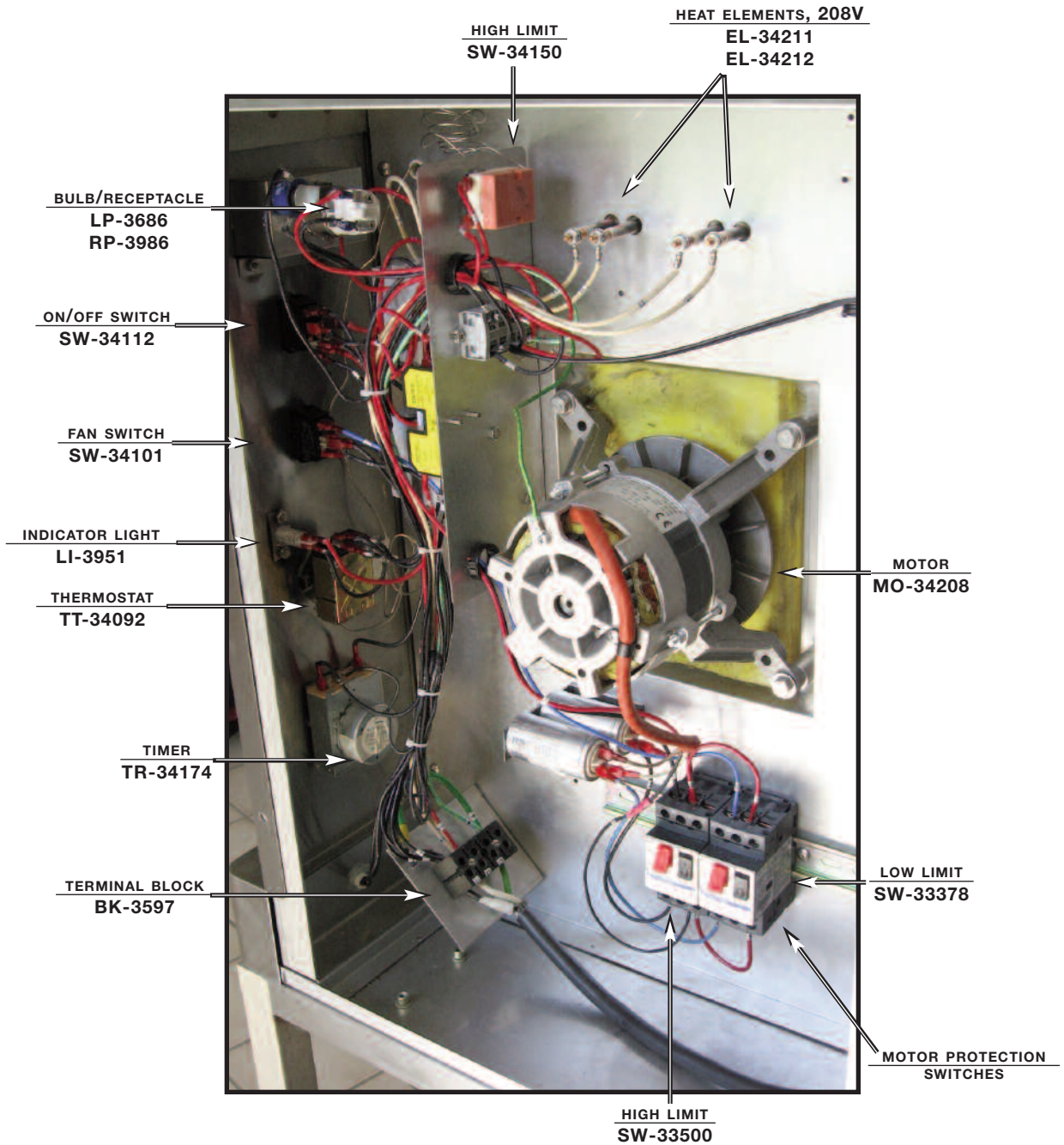

ASC-2E

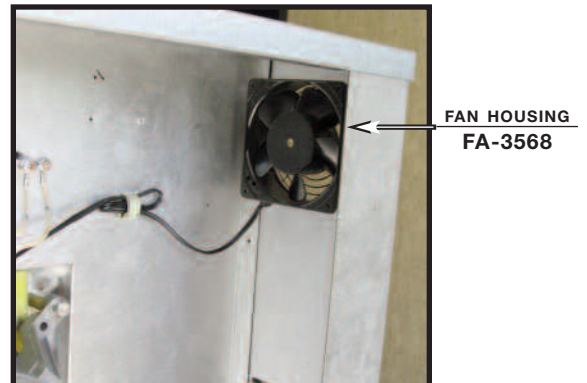

SERVICE - ASC-4E

! DANGER

Service must be in accordance with all local codes and must be performed by a qualified service technician.

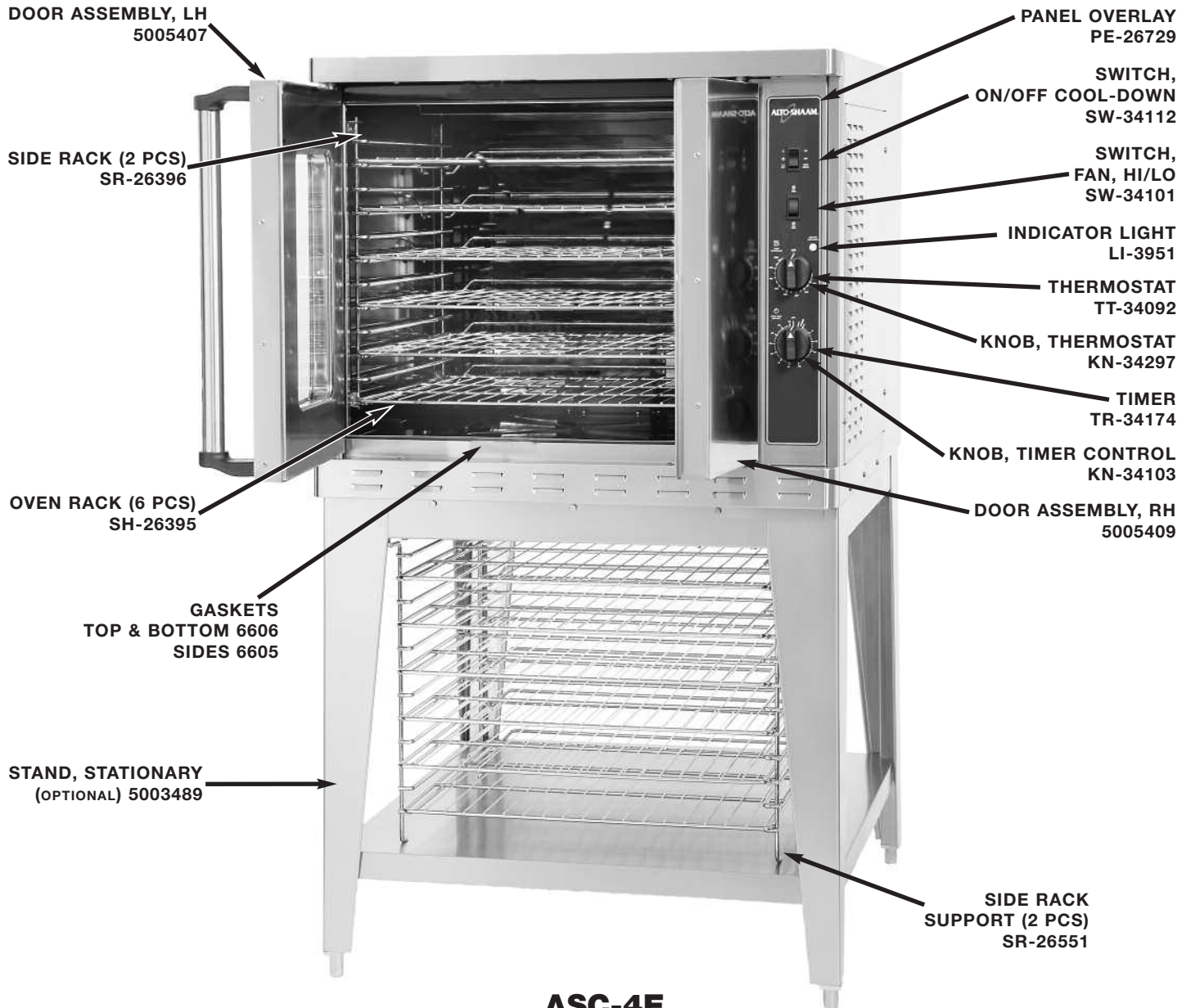

ASC-4E



! DANGER

DISCONNECT UNIT FROM POWER SOURCE BEFORE CLEANING OR SERVICING.

SERVICE - ASC-4E

INTERIOR OVEN COMPARTMENT

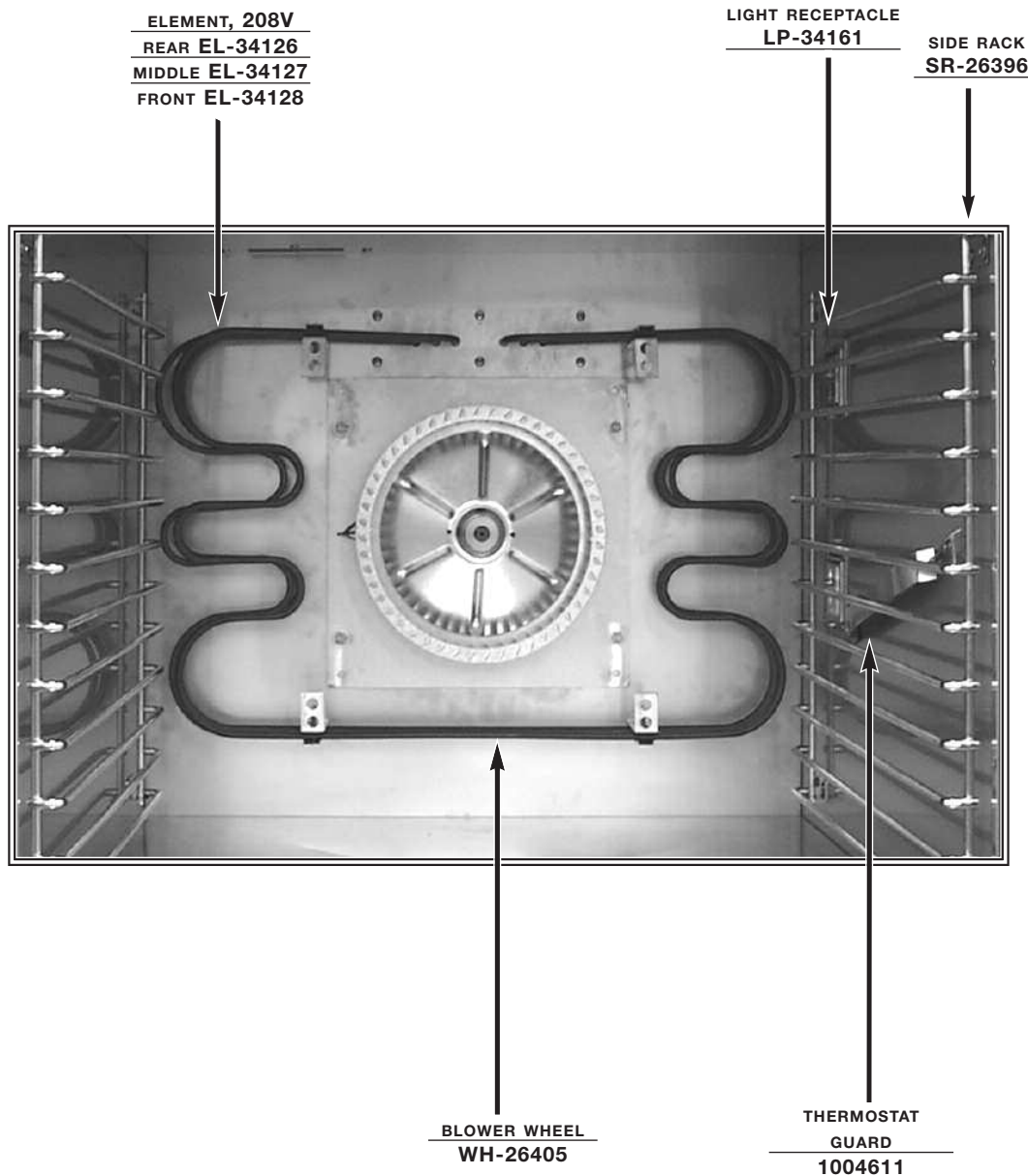

ASC-4E oven interior

SERVICE - ASC-4E

RIGHT SIDE SERVICE PANEL - REMOVED

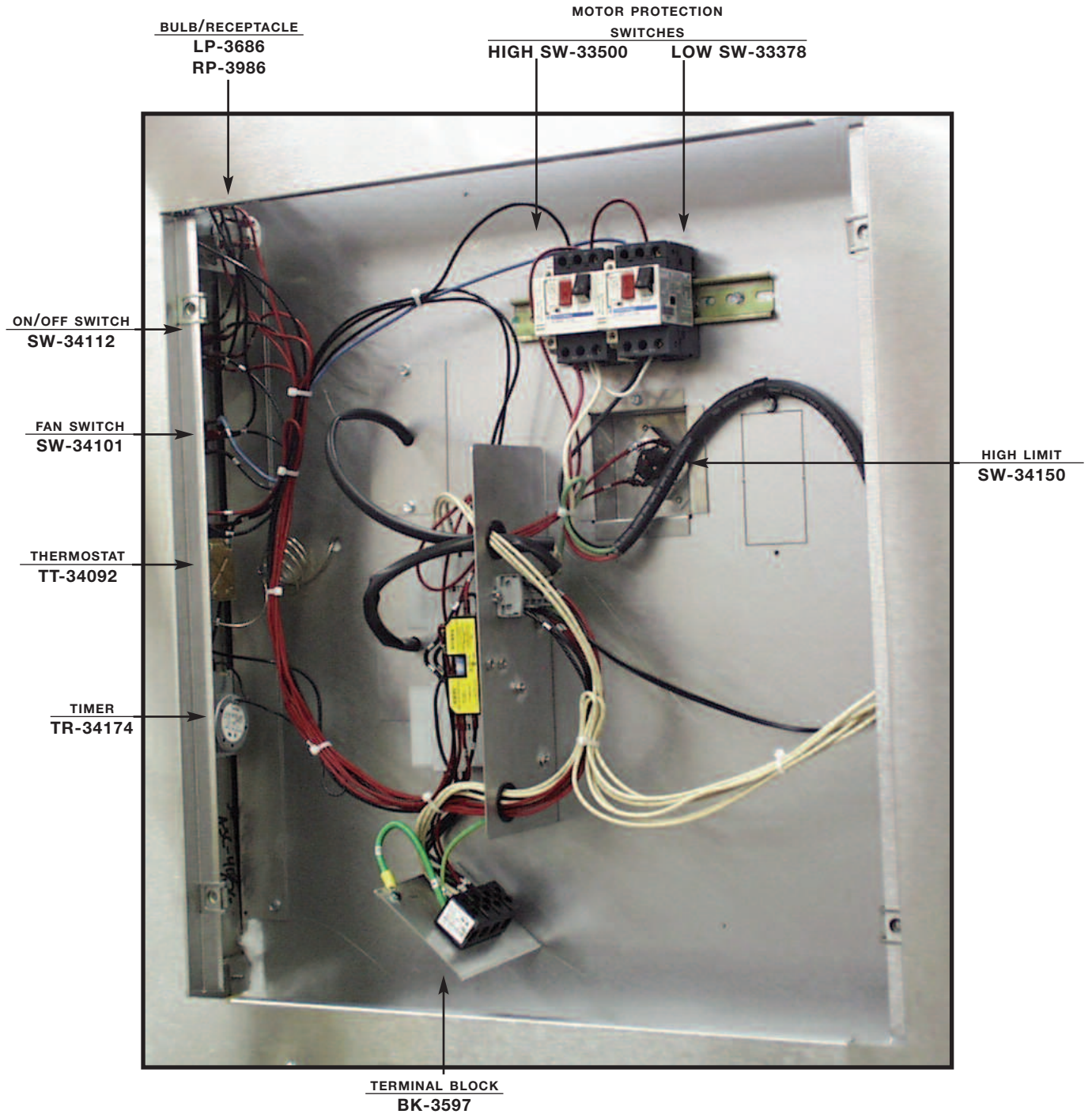

ASC-4E

SERVICE - ASC-4E

REAR PANEL - REMOVED

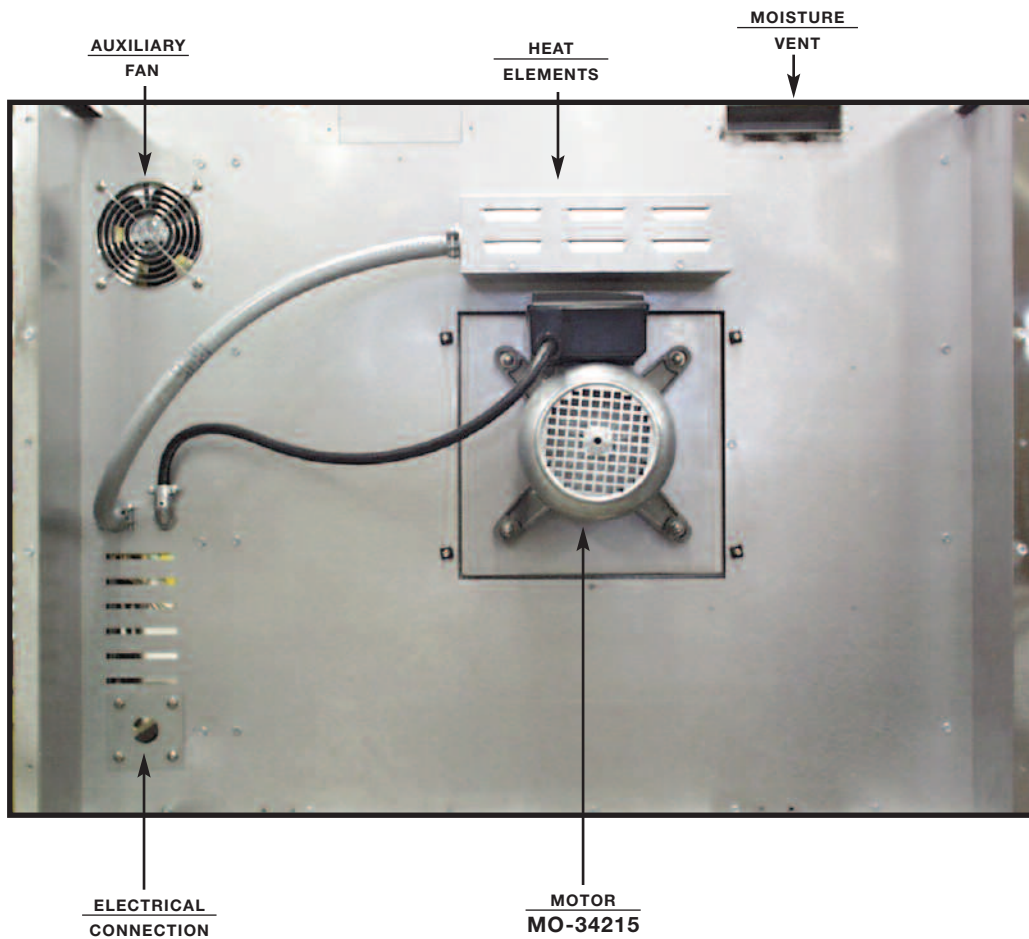

ASC-4E

SERVICE PARTS LIST

Description	ASC-2E	ASC-4E	Qty.
	Part No.	Part No.	
Cosmetic/Exterior Components			
Panel, Top and Side	1005455	1006623	1
Gasket, LH/RH	1005311	1006605	2
Gasket, Top/Bottom	1005316	1006606	2
Panel, Service, louvered	1006602	1006672	1
Cover, Bottom	1005458	1006678	1
Cover, Top	1005459	1006679	1
Interior			
Rack, Side	SR-26893	SR-26396	2
Shelf	SH-26894	SH-26795	5 / 6
Lamp, *CT, snap-in, oven light	--	LP-34161	2
Gasket, oven lamp	--	GS-26630	2
Glass, *CT, oven lamp	--	GL-26608	2
Cover for oven light	--	CV-26607	2
Receptacle, Lamp	--	RP-3986	1
Oven Elements			
Element, Outer, 208V	EL-34211	--	1
Element, Inner, 208V	EL-34212	--	1
Element, Rear, 208V	--	EL-34126	1
Element, Center, 208V	--	EL-34127	1
Element, Front, 208V	--	EL-34128	1
Element, Inner, 240V	EL-34209		1
Element, Outer, 240V	EL-34210		1
Element, Rear, 240V	--	EL-34129	1
Element, Center, 240V	--	EL-34146	1
Element, Front, 240V	--	EL-34125	1
Motor/Blower Wheel			
Motor, 208/240V	MO-34208	MO-34215	1
Wheel, Blower	WH-26895	WH-26405	1
Door Assembly			
Assembly, Complete	5004352		1
Assembly, Complete, RH	--	5005407	1
Assembly, Complete, LH	--	5005409	1
Switches/Thermostats/Timers			
Block, Terminal	BK-3597	BK-3597	1
Block, Modular	BK-25567	BK-25567	1
Buzzer	BZ-34113	BZ-34113	1
Contactors, *CT, 240V, 50A	CN-3731	CN-3731	1 / 2
Fan, Box, 70CFM, 230V, 50-60HZ	FA-3568	FA-3568	1
Fuse Holder, Dual, 15A, Class G	FU-3772	FU-3772	1
Fuses, *CT, 15A, Class G	FU-3775	FU-3775	2
Guard, Fan	GD-2396	GD-2396	1
Knob, Control, Indicating	KN-34103	KN-34103	1
Knob, Thermostat	KN-34297	KN-34297	1
Light Indicator	LI-3025	LI-3025	1
Panel Overlay	PE-26978	PE-26729	1
Switch, Rocker, Fan, High/Low	SW-34101	SW-34101	1
Switch, On/Off/Cool-down	SW-34112	SW-34112	1
Switch, High Limit	TT-3750	SW-34150	1
Switch, Door, Roller	SW-34164	SW-34164	1
Switch, Motor Protect	SW-33500	SW-33550	1
Switch, Motor Protect	SW-33378	SW-33378	1
Timer, 250V, 1 hr	TR-34174	TR-34174	1
Thermostat, 140-500 Deg. F	TT-34092	TT-34092	1



DANGER

DISCONNECT UNIT FROM
POWER SOURCE BEFORE
CLEANING OR SERVICING.

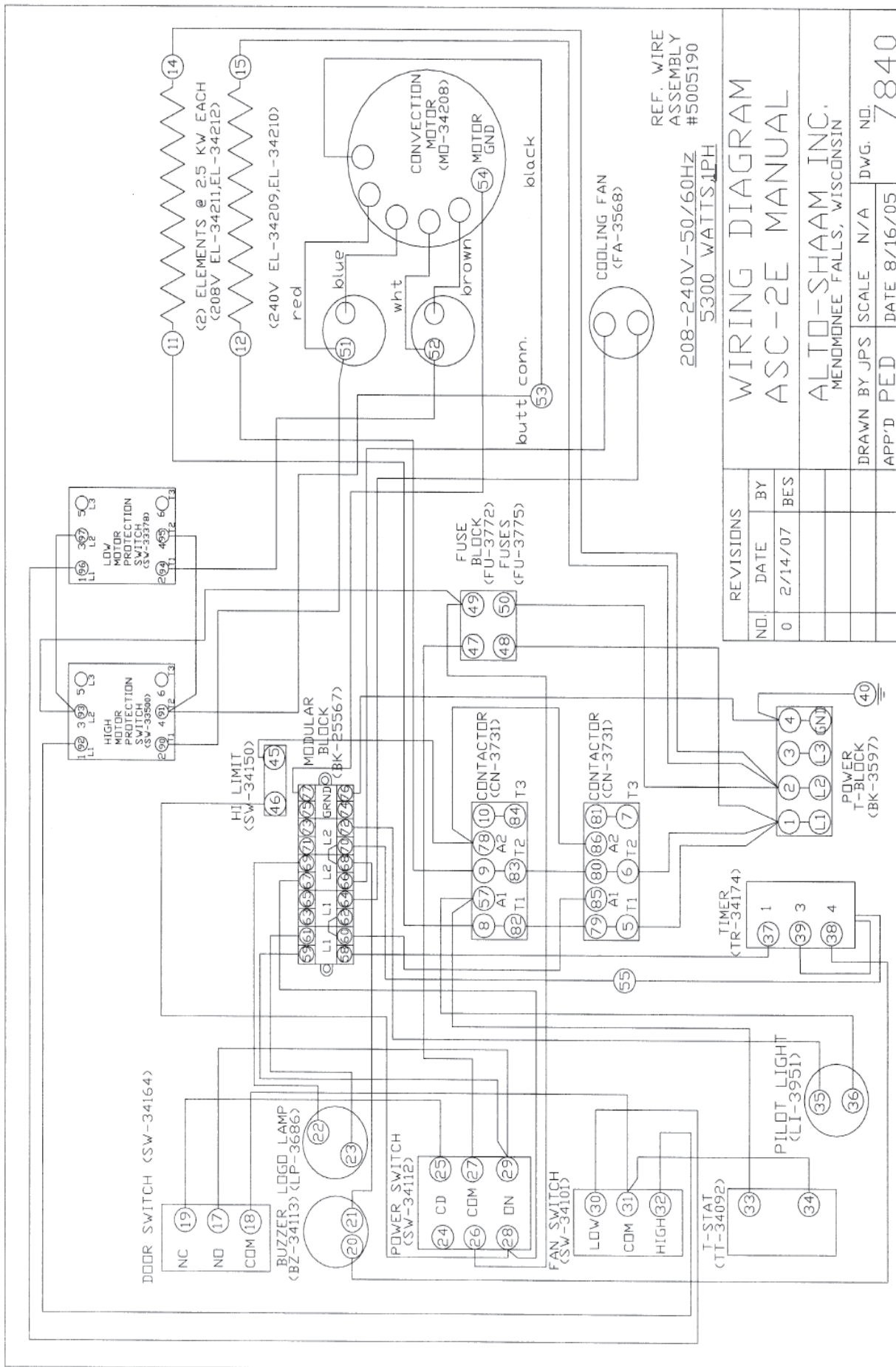

WIRING DIAGRAM
 ASC-2E MANUAL

ALTO-SHAAM INC.
 MENOMONEE FALLS, WISCONSIN

REVISIONS	
NO.	DATE BY
0	2/14/07 BES

DRAWN BY	JPS	SCALE	N/A	DWG. NO.	7840
APP'D	PED	DATE	8/16/05		

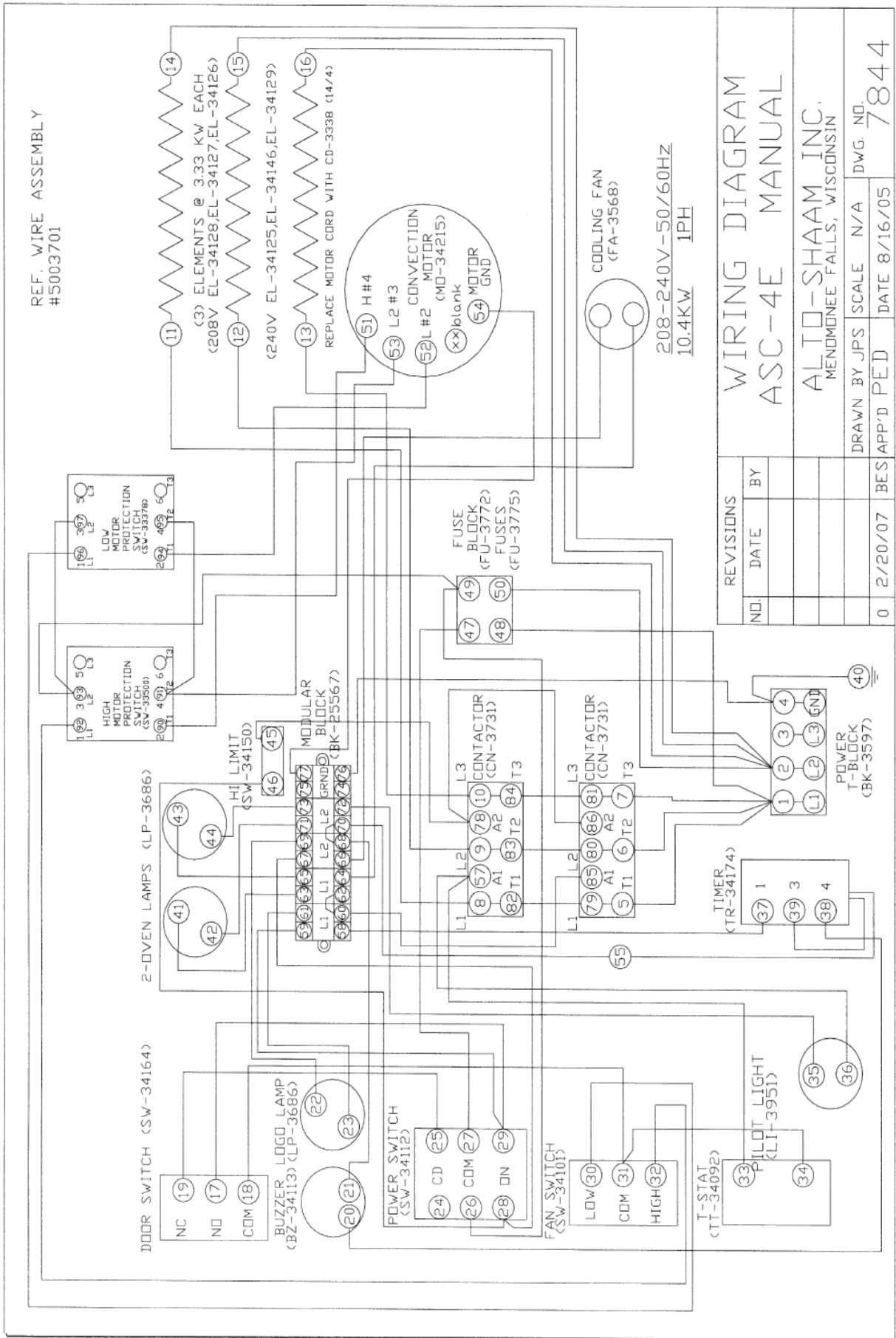

WIRING DIAGRAM
ASC-4E MANUAL

NO.	DATE	BY
0	2/20/07	BES

ALTO-SHAAM INC.
MENDOTA FALLS, WISCONSIN

DRAWN BY JPS SCALE N/A
DATE 8/16/05

BEST APP'D PED

DWG. NO. 7844

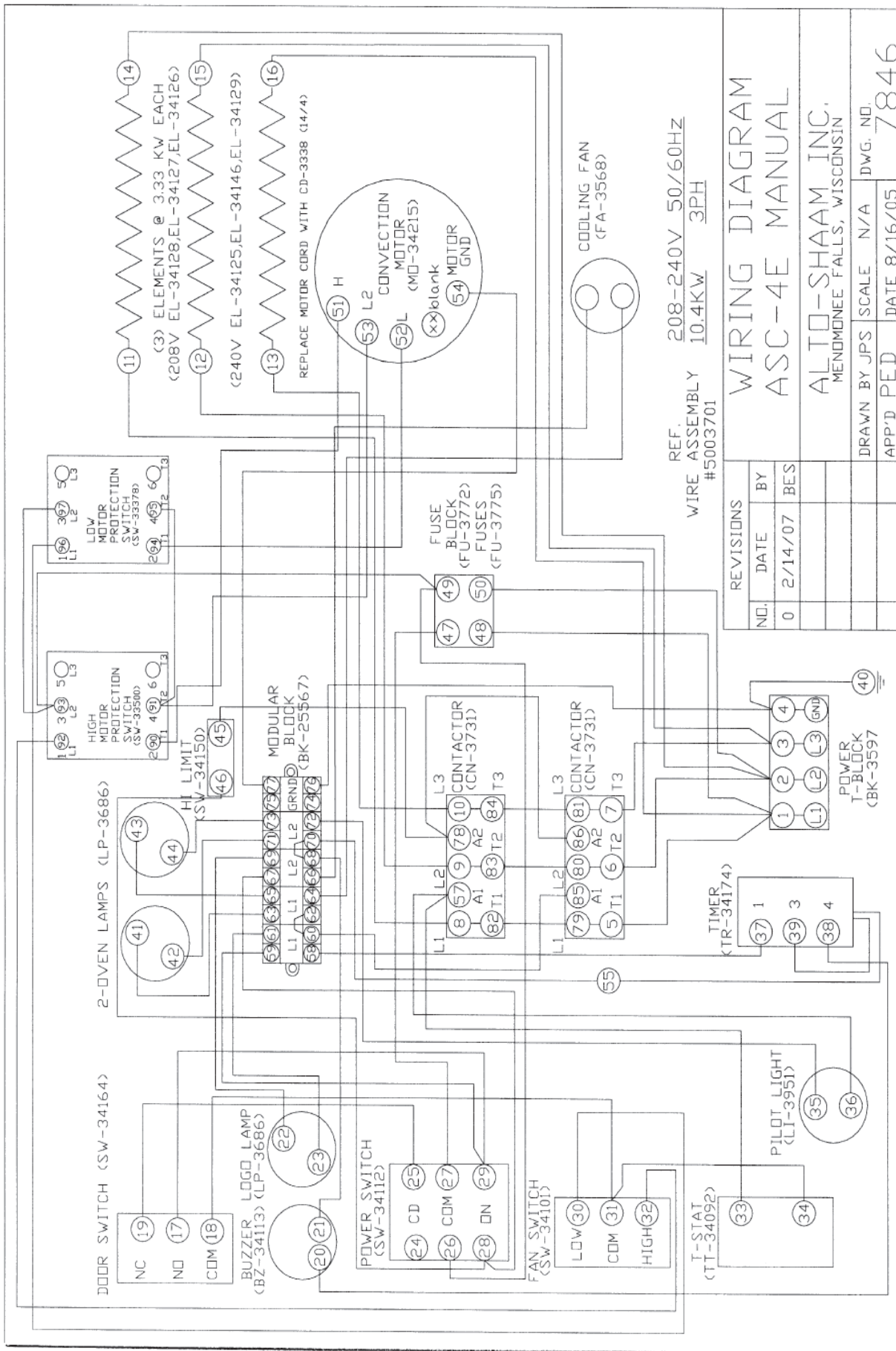

REF. 208-240V 50/60HZ
 WIRE ASSEMBLY 10.4KW 3PH #5003701

WIRING DIAGRAM
 ASC-4E MANUAL

ALTO-SHAAM INC.
 MEMONNEE FALLS, WISCONSIN

REVISIONS	DATE	BY
0	2/14/07	BES

DRAWN BY	JPS	SCALE	N/A	DWG. NO.	7846
APP'D	PED	DATE	8/16/05		

TRANSPORTATION DAMAGE and CLAIMS

ALTO SHAAM. LIMITED WARRANTY



All Alto-Shaam equipment is sold F.O.B. shipping point, and when accepted by the carrier, such shipments become the property of the consignee.

Should damage occur in shipment, it is a matter between the carrier and the consignee. In such cases, the carrier is assumed to be responsible for the safe delivery of the merchandise, unless negligence can be established on the part of the shipper.

1. Make an immediate inspection while the equipment is still in the truck or immediately after it is moved to the receiving area. Do not wait until after the material is moved to a storage area.
2. Do not sign a delivery receipt or a freight bill until you have made a proper count and inspection of all merchandise received.
3. Note all damage to packages directly on the carrier's delivery receipt.
4. Make certain the driver signs this receipt. If he refuses to sign, make a notation of this refusal on the receipt.
5. If the driver refuses to allow inspection, write the following on the delivery receipt:
Driver refuses to allow inspection of containers for visible damage.
6. Telephone the carrier's office immediately upon finding damage, and request an inspection. Mail a written confirmation of the time, date, and the person called.
7. Save any packages and packing material for further inspection by the carrier.
8. Promptly file a written claim with the carrier and attach copies of all supporting paperwork.

We will continue our policy of assisting our customers in collecting claims which have been properly filed and actively pursued. We cannot, however, file any damage claims for you, assume the responsibility of any claims, or accept deductions in payment for such claims.

Alto-Shaam, Inc. warrants to the original purchaser that any original part that is found to be defective in material or workmanship will, at Alto-Shaam's option, subject to provisions hereinafter stated, be replaced with a new or rebuilt part.

The labor warranty remains in effect one (1) year from installation or fifteen (15) months from the shipping date, whichever occurs first. Alto-Shaam will bear normal labor charges performed during standard business hours, and excluding overtime, holiday rates or any additional fees.

The parts warranty remains in effect for one (1) year from installation or fifteen (15) months from the shipping date, whichever occurs first.

However, the heating element on Halo Heat® cook/hold ovens and the refrigeration compressor on Alto-Shaam Quickchillers™ are warranted for a period of five (5) years from installation. The labor warranty is the same as stated above; namely, for one (1) year from installation or fifteen (15) months from the shipping date, whichever occurs first.

THIS WARRANTY DOES NOT APPLY TO:

1. Calibration.
2. Replacement of light bulbs and/or the replacement of display case glass due to damage of any kind.
3. Equipment damage caused by accident, shipping, improper installation or alteration.
4. Equipment used under conditions of abuse, misuse, carelessness or abnormal conditions including, but not limited to, equipment subjected to harsh or inappropriate chemicals including, but not limited to, compounds containing chloride or quaternary salts, poor water quality, or equipment with missing or altered serial numbers.
5. Damage incurred as a direct result of poor water quality, inadequate maintenance of steam generators and/or surfaces affected by water quality. Water quality and required maintenance of steam generating equipment is the responsibility of the owner/operator.
6. Damage caused by use of any cleaning agent other than Alto-Shaam's Combitherm® Cleaner including, but not limited to, damage due to chlorine or other harmful chemicals. Use of Alto-Shaam's Combitherm® Cleaner on Combitherm® ovens is highly recommended.
7. Any losses or damage resulting from malfunction, including loss of product or consequential or incidental damages of any kind.
8. Equipment modified in any manner from original model, substitution of parts other than factory authorized parts, removal of any parts including legs, or addition of any parts.

This warranty is exclusive and is in lieu of all other warranties, expressed or implied, including the implied warranties of merchantability and fitness for a particular purpose. In no event shall Alto-Shaam be liable for loss of use, loss of revenue or profit, or loss of product, or for any indirect or consequential damages. No person except an officer of Alto-Shaam, Inc. is authorized to modify this warranty or to incur on behalf of Alto-Shaam any other obligation or liability in connection with Alto-Shaam equipment.

ALTO-SHAAM, INC.

RECORD THE MODEL AND SERIAL NUMBER OF THE APPLIANCE FOR EASY REFERENCE.
ALWAYS REFER TO BOTH MODEL AND SERIAL NUMBER IN ANY CONTACT WITH ALTO-SHAAM REGARDING THIS APPLIANCE.

Model: _____ Date Installed: _____
Voltage: _____ Purchased From: _____
Serial Number: _____

W164 N9221 Water Street • P.O. Box 450 • Menomonee Falls, Wisconsin 53052-0450 • U.S.A.
PHONE: 262.251.3800 • 800.558-8744 USA/CANADA FAX: 262.251.7067 • 800.329.8744 U.S.A. ONLY
WEBSITE: www.alto-shaam.com

PRINTED IN U.S.A.

Free Manuals Download Website

<http://myh66.com>

<http://usermanuals.us>

<http://www.somanuals.com>

<http://www.4manuals.cc>

<http://www.manual-lib.com>

<http://www.404manual.com>

<http://www.luxmanual.com>

<http://aubethermostatmanual.com>

Golf course search by state

<http://golfingnear.com>

Email search by domain

<http://emailbydomain.com>

Auto manuals search

<http://auto.somanuals.com>

TV manuals search

<http://tv.somanuals.com>