

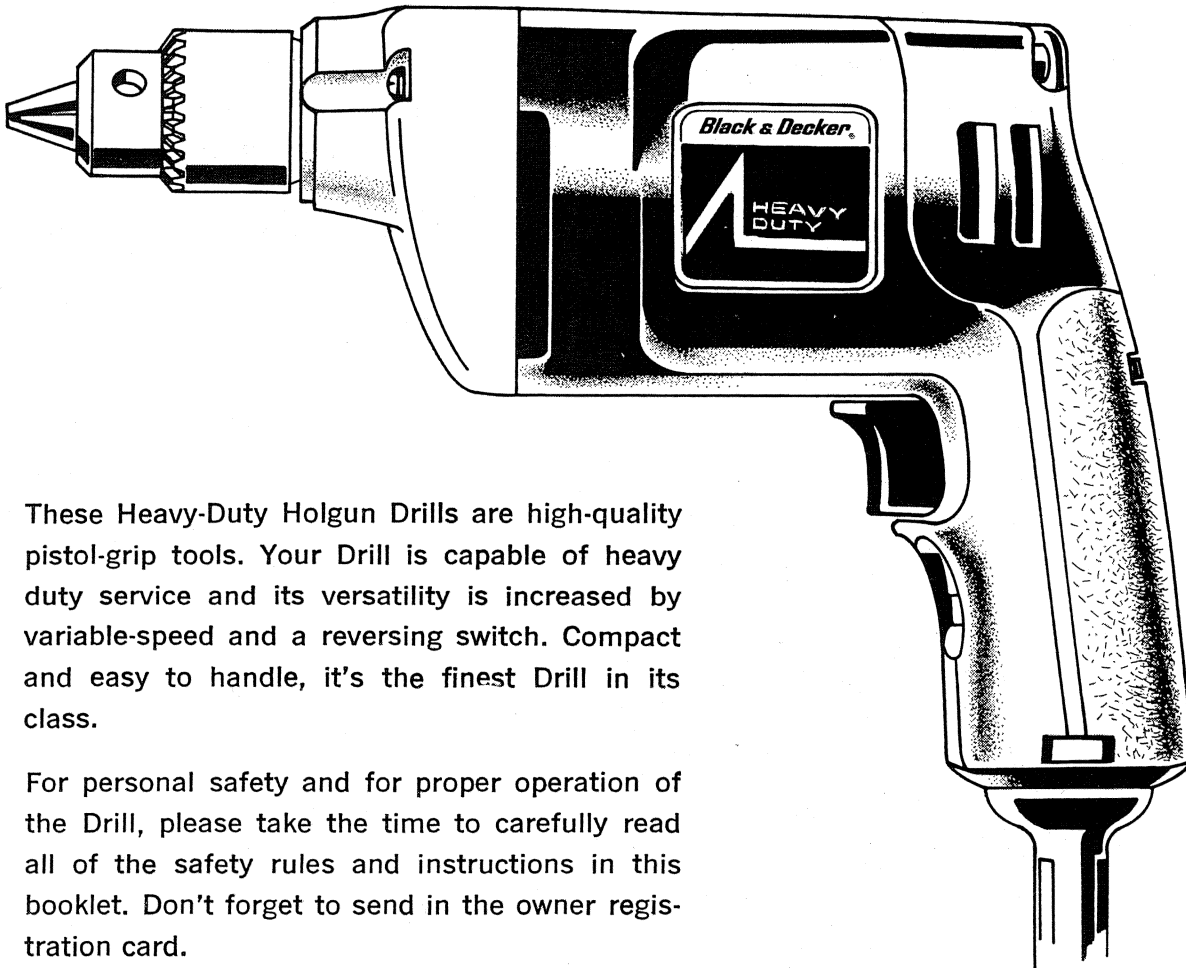

Black & Decker®

OWNER'S MANUAL



These Heavy-Duty Holgun Drills are high-quality pistol-grip tools. Your Drill is capable of heavy duty service and its versatility is increased by variable-speed and a reversing switch. Compact and easy to handle, it's the finest Drill in its class.

For personal safety and for proper operation of the Drill, please take the time to carefully read all of the safety rules and instructions in this booklet. Don't forget to send in the owner registration card.

THANK YOU for buying BLACK & DECKER!

HEAVY-DUTY HOLGUN® DRILLS

1/4" DRILL	3/8" DRILL	1/2" DRILL	DUAL RANGE DRILL
Cat. Nos.	Cat. Nos.	Cat. No.	Cat. No.
1030-10	1172-10	1310-10	1170-10
6009-10	6029-10		

• DOUBLE INSULATED •

IMPORTANT INFORMATION

SAFETY RULES FOR POWER TOOLS

1. **KNOW YOUR POWER TOOL**—Read owner's manual carefully. Learn its applications and limitations as well as the specific potential hazards peculiar to this tool.
2. **GROUND ALL TOOLS — UNLESS DOUBLE-INSULATED.** If tool is equipped with three-prong plug, it should be plugged into a three-hole electrical receptacle. If adapter is used to accommodate two-prong receptacle, the adapter wire must be attached to a **known ground**. **Never** remove third prong.
3. **KEEP GUARDS IN PLACE** and in working order.
4. **KEEP WORK AREA CLEAN.** Cluttered areas and benches invite accidents.
5. **AVOID DANGEROUS ENVIRONMENT.** Don't expose power tools to rain. Don't use power tool in damp or wet locations. And keep work area well lit.
6. **KEEP CHILDREN AWAY.** All visitors should be kept safe distance from work area.
7. **STORE IDLE TOOLS.** When not in use, tools should be stored in dry, high or locked-up place — out of reach of children.
8. **DON'T FORCE TOOL.** It will do the job better and safer at the rate for which it was designed.
9. **USE RIGHT TOOL.** Don't force small tool or attachment to do the job of a heavy duty tool.
10. **WEAR PROPER APPAREL.** No loose clothing or jewelry to get caught in moving parts. Rubber gloves and footwear are recommended when working outdoors.
11. **USE SAFETY GLASSES** with most tools. Also face or dust mask if cutting operation is dusty.
12. **DON'T ABUSE CORD.** Never carry tool by cord or yank it to disconnect from receptacle. Keep cord from heat, oil and sharp edges.
13. **SECURE WORK.** Use clamps or a vise to hold work. It's safer than using your hand and it frees both hands to operate tool.
14. **DON'T OVERREACH.** Keep proper footing and balance at all times.
15. **MAINTAIN TOOLS WITH CARE.** Keep tools sharp at all times, and clean for best and safest performance. Follow instructions for lubricating and changing accessories.
16. **DISCONNECT TOOLS.** When not in use, before servicing; when changing accessories such as blades, bits, cutters, etc.
17. **REMOVE ADJUSTING KEYS AND WRENCHES.** Form habit of checking to see that keys and adjusting wrenches are removed from tool before turning it on.
18. **AVOID ACCIDENTAL STARTING.** Don't carry plugged-in tool with finger on switch. Be sure switch is off when plugging in.
19. **OUTDOOR USE EXTENSION CORDS —** When tool is used outdoors, use only extension cords suitable for use outdoors and so marked.
20. **DO NOT OPERATE** portable electric tools in gaseous or explosive atmospheres. Motors in these tools normally spark, and the sparks might ignite fumes.

DOUBLE INSULATION

Your Drill is DOUBLE-INSULATED to give you added safety. This means that it is constructed throughout with TWO separate "layers" of electrical insulation or one DOUBLE thickness of insulation between you and the tool's electrical system.

Tools built with this insulation system are not intended to be grounded. As a result, your Drill is equipped with a two-prong plug which permits you to use extension cords without concern for maintaining a ground connection.

NOTE: DOUBLE-INSULATION does not take the place of normal safety precautions when operating this tool. The insulation system is for added protection against injury resulting from a possible electrical insulation failure within the tool.

CAUTION: When servicing Double Insulated Tools. USE ONLY IDENTICAL REPLACEMENT PARTS. Repair or replace damaged cords.

EXTENSION CORD

When using the tool at a considerable distance from power source, an extension cord of **adequate size** must be used **for safety**, and to prevent loss of power and over-heating. Use the table below to determine minimum wire size.

Before using extension cords, inspect them for loose or exposed wires and damaged insulation. Make any needed repairs or replacement before using with your power tool.

Ampere rating (on nameplate)	0 to 2.0	2.10 to 3.4	3.5 to 5.0	5.10 to 7.0	7.10 to 12.0	12.1 to 16.0
Ext. Cable length	Wire Size (A.W.G.)					
25 ft.	18	18	18	18	16	14
50 ft.	18	18	18	16	14	12
75 ft.	18	18	16	14	12	10
100 ft.	18	16	14	12	10	—
150 ft.	16	14	12	12	—	—
200 ft.	16	14	12	10	—	—

MOTOR

Your Black & Decker tool is powered by a B & D-built motor. Be sure your power supply agrees with the nameplate marking.

Volts 50/60 Hz or "AC only" means your tool must be operated only with alternating current and **never** with direct current. Volts DC-60Hz or AC/DC means your tool may be operated with either alternating or direct current.

Voltage decrease of more than 10% will cause loss of power and overheating. All B&D tools are factory tested; if this tool does not operate, check the power supply.

All Reversing Tools have full power and perform as well in REVERSE as they do in FORWARD.

MOTOR BRUSHES

Your Drill uses the B & D "Checkpoint" brush system. The tool will stop when the brushes wear out (down to about $\frac{3}{16}$ " long). This prevents damage to the motor.

SWITCHES

To start Drill, depress trigger switch; to stop Drill, release trigger. To lock trigger in "ON" position for continuous operation, depress trigger and push up locking button "A" Figure 1, then gently release trigger. To release locking mechanism, depress trigger fully, then release it. Before using the tool (each time) be sure that the lock button release mechanism is working freely.

Do not lock the switch "ON" when drilling by hand so that you can instantly release the trigger switch if the bit binds in the hole.

Be sure to release the switch locking button before disconnecting the plug from the power supply. Failure to do so will cause the tool to start immediately the next time it is plugged in. Damage or injury could result.

The Variable Speed Trigger Switch permits speed control — the farther the trigger is depressed, the higher the speed of the Drill. **NOTE:** Use lower speeds for starting holes without a center punch, drilling in metal or plastics, driving screws, drilling ceramics, or mixing paint. Higher speeds are better for drilling wood and composition boards, and for using abrasive and polishing accessories.

The Reversing Switch is used for withdrawing bits from tight holes and removing screws at lower speeds. It is located on the back of the handle (Fig. 2). To reverse the motor, release the trigger FIRST and then push the switch toward "R". After any reversing operations, return switch to forward position by pushing it toward "F".

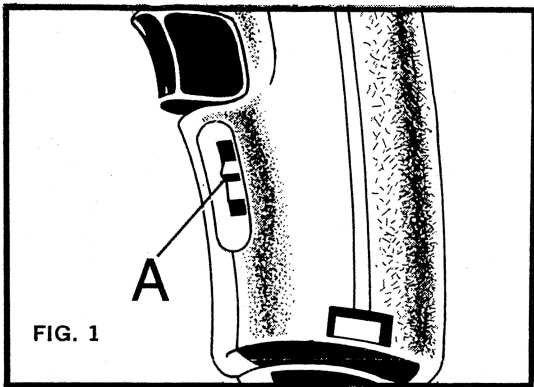

FIG. 1

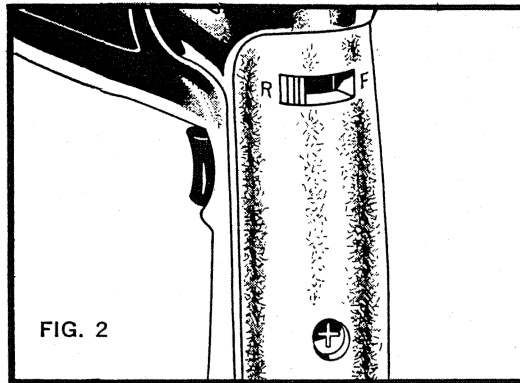

FIG. 2

DUAL RANGE OPERATION

The 1170-10 Dual Range Holgun® Drill features a shift lever located on the underside of the gear case. This shift lever enables you to select the gear reduction best suited for your job. When the shift lever indicates "H" (High), facing outward, the gear reduction will allow the chuck to rotate from 0-2500 RPM. When the shift lever indicates "L" (Low), the gear reduction will allow the chuck to rotate from 0-1200 RPM giving the maximum amount of power (torque) applied at the chuck. Shifting is accomplished by lifting the shift lever from slot in casting and rotating 180° around, returning the lever flat in slot against casting (Fig. 3). **NOTE:** When shifting the gears from one reduction to another, make sure the tool is not running and that the shift lever is re-engaged in the slot against the gear case housing after shifting.

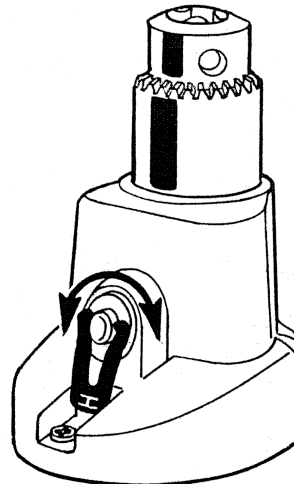

FIG. 3

CAUTION: When drilling into walls, floors or wherever “live” electrical wires may be encountered, DO NOT TOUCH THE CHUCK OR ANY FRONT METAL PARTS OF THE DRILL! Hold the Drill only by the plastic handle to prevent shock if you drill into a “live” wire.

TWO-POSITION SIDE HANDLE

This handle is supplied with ½” drills only. It screws into the threaded hole on either the right-hand or left-hand side of the gear case.

CAUTION: Always use the side handle and hold the drill with both hands when using ½” drills.

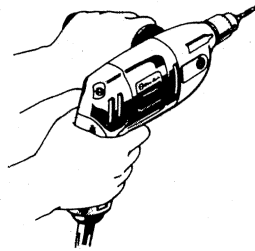

OPERATION

DRILLING

1. Always unplug the Drill when attaching or changing bits or accessories.
2. Open chuck jaws by turning collar with fingers and insert shank of bit about ¾” into chuck. Tighten chuck collar by hand. Place chuck key in each of the three holes, and tighten in clockwise direction. It’s important to tighten chuck with all three holes. To release bit, turn chuck key counter clockwise in just one hole, then loosen chuck by hand.
3. Use sharp drill bits only. For WOOD, use twist drill bits, spade bits, power auger bits, or hole saws. For METAL, use high-speed steel twist drill bits or hole saws. For MASONRY, such as brick, cement, cinder block, etc., use carbide-tipped bits.
4. Be sure the material to be drilled is anchored or clamped **firmly**. If drilling thin material, use a wood “back-up” block to **prevent** damage to the material.
5. With Variable Speed Drills there is no need to center punch the point to be drilled. Use a slow speed to start the hole and accelerate by squeezing the trigger harder when the hole is deep enough to drill without the bit skipping out.
6. Always apply pressure in a straight line with the bit. Use enough pressure to keep drill biting, but do not push hard enough to stall the motor or deflect the bit.
7. Hold drill firmly to control the twisting action of the drill.
8. IF DRILL STALLS, it is usually because it is being overloaded or improperly used. RELEASE TRIGGER IMMEDIATELY, remove drill bit from work, and determine cause of stalling. DO NOT CLICK TRIGGER OFF AND ON IN AN ATTEMPT TO START A STALLED DRILL — THIS CAN DAMAGE THE DRILL.
9. To minimize stalling on breaking through the material, reduce pressure on drill and ease the bit through the last fractional part of the hole.
10. Keep the motor running when pulling the bit back out of a drilled hole. This will help prevent jamming.

DRILLING IN METAL

Use a cutting lubricant when drilling metals. The exceptions are cast iron and brass which should be drilled dry. The cutting lubricants that work best are sulphurized cutting oil or lard oil; bacon grease will also serve the purpose. Aluminum is best drilled with kerosene.

DRILLING IN WOOD

Holes in wood can be made with the same twist drills used for metal. These bits may overheat unless pulled out frequently to clear chips from the flutes. For larger holes, use Power Drill Wood Bits. Work that is apt to splinter should be backed up with a block of wood.

DRILL ACCESSORIES

Recommended accessories for your Drill are shown in this manual and in Black & Decker Catalogs. (CAUTION: The use of any other accessory might be hazardous.) For safety in use, the following accessories should be used only in sizes up to the maximums shown in the table below.

The accessories listed in this manual are available at extra cost from your local dealer, Black & Decker Service Center, or by writing to: Customer Services, Black & Decker (U.S.) Inc., Towson, Maryland 21204

MAXIMUM RECOMMENDED CAPACITIES

TOOL CAT. NOS. →	1030-10 6009-10	1172-10 6029-10	1170-10	1310-10	
ACCESSORY R.P.M. →	0-2500	0-1200	0-1200	0-550	
BITS, METAL DRILLING	1/4"	3/8"	3/8"	1/4"	1/2"
BITS, WOOD DRILLING	3/4"	1 1/4"	1 1/4"	3/4"	1 1/2"
BITS, MASONRY DRILLING	1/2"	5/8"	5/8"	1/2"	5/8"
HOLE SAWS	1 1/8"	1 1/2"	1 1/2"	1 1/8"	2"

WIRE WHEEL BRUSHES
4" Diameter Maximum
WIRE CUP BRUSHES
3" Diameter Maximum
BUFFING WHEELS
3" Diameter Maximum
RUBBER BACKING
PADS
4 5/8" Dia. Maximum

ACCESSORY MUST BE RATED FOR USE AT SPEED EQUAL TO OR HIGHER THAN NAMEPLATE R.P.M. OF TOOL WITH WHICH IT IS BEING USED.

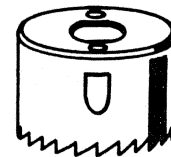

HOLE SAW MANDRELS

For 1/4", 3/8", and 1/2" Drills

to fit 3/4" to 1 1/8" Hole Saws	No. 40093	Mandrel with Pilot Drill
to fit 1 1/4" to 1 1/2" Hole Saws	No. 40094	Mandrel with Pilot Drill
to fit above Mandrels	No. 22192	High Speed Steel Pilot Drill Only

Also available: No. 14935 Pilot drill; fits former Mandrels Nos. 14903, 14904 and 18028. No. 22192 Pilot drill; fits former Mandrels Nos. 22181 and 22182.

HIGH-SPEED HOLE SAWS

Use with Mandrels		(Former Nos. in parentheses)		
Saw Outside Diam.	Cat. No.	For 1/4", 3/8", 1/2" Drills	For Conduit Sizes	For Pipe Tap Sizes
5/8"	36468	5/8" Hole Saw has built-in Mandrel; no separate Mandrel supplied.		
3/4"	21747	40093 (22181)	3/8"	
7/8"	21748	40093 (22181)	1/2"	
1 1/8"	21749	40093 (22181)		3/4"
1"	21771	40093 (22181)		
1 1/8"	22809	40093 (22181)		
1 1/8"	21772	40093 (22181)	3/4"	
1 1/8"	21773	40093 (22181)		1"
1 1/4"	21781	40094 (22182)		
1 3/8"	21782	40094 (22182)	1"	
1 1/2"	21783	40094 (22182)		1 1/4"

Carbon Removing Brushes

Made of tempered-steel wire; used with 1/4" drills to remove rust and scale from metals. Leaves a burnished surface.

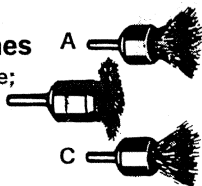

- A. No. 21416 Heavy-duty solid wire-filled brush.
- B. No. 21417 Side-flare brush for close corner work.
- C. No. 21419 Hollow-core, flare-bottom brush.
- No. 21418 Small cleaning brush. (Not shown.)

3" Wire Cup Brush

Use in cleaning and removing rust, scale, old paint.



No. 39014 (straight chuck shank). Max. safe RPM—5,000.

Heavy-Duty Tool Box

Cat. No. 50078
13" x 8 1/2" x 3/4"



Drill Stop

Capacity 1/4" to 1/2".
Governs drilling depth.
No. C 1578 Drill Stop.

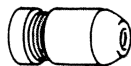

Round-Shank Masonry Bits

These bits are carbide-tipped for top performance and extra-long life in most masonry-drilling applications.

Wire Wheel Brushes

Use in cleaning and removing rust, scale, old paint.

- No. 39008 4" Fine Brush, crimped; Max. safe RPM—4,500
- No. 39009 4" Coarse Brush, crimped; Max. safe RPM—4,500



Wheel Arbors

Fit 1/4" to 1/2" Drills. Carry grinding wheels, wire wheel brushes and buffing wheels.

- No. 39026 1/4" Arbor (1/2" dia., 1/4" shank).
- No. 8449 1/2" Arbor (1/2" dia., 1/2" shank).



Buffing Wheels

Use with 1/4" to 1/2" Drills and Wheel Arbors.

- No. 39015 3" x 3/8" x 1/2" Cotton Buff.



Rubber Backing Pad

Fit 1/4" to 1/2" Drills.

- No. 66547 4 5/8" Rubber Backing Pad with plain shank.



Cat. No.	Bit Diam. (in.)	Usable Drilling Depth (in.)	Shank Diam. (in.)
55702	3/16	1 1/2	3/16
55703	1/4	2	1/4
55704	5/16	2 1/4	1/4
55705	3/8	2 1/2	1/4
55706	1/2	2 1/2	1/4
56932	5/8	4 1/4	1/4

CHUCK REMOVAL

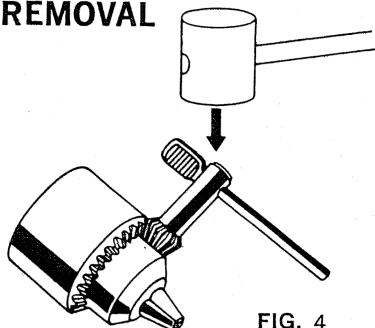

FIG. 4

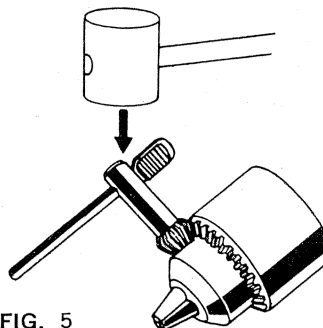
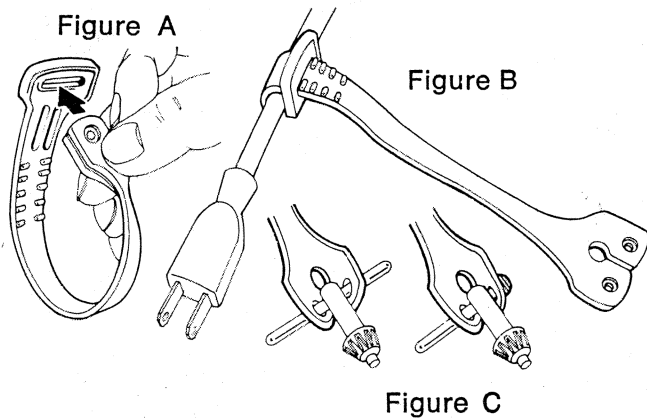

FIG. 5

For Reversing Drills, start with step 1.

For Non-Reversing Drills, skip steps 1 & 2 and start with step 3.

1. Place chuck key in chuck as shown in Figure 4. Using a wooden mallet or similar object, strike key sharply in a CLOCKWISE direction. This will loosen screw inside chuck (Figure 4).
2. Open chuck jaws fully. Insert screwdriver into front of chuck between jaws to engage screw head. Remove screw by turning clockwise (left-hand thread).
3. Place key in chuck as shown in Figure 5. Using a wooden mallet or similar object, strike key sharply in a COUNTER-CLOCKWISE direction (Figure 5). This will loosen chuck so that it can be unscrewed by hand.



CHUCK KEY HOLDER

1. Push double-hole end of Holder through slot in other end of Holder (Figure A).
2. Slip loop over electric plug and draw loop tight around cord (Figure B).
3. Push ends of Chuck Key Handle through two holes in end of Holder (Figure C).

LUBRICATION

All ball bearings used are factory lubricated to last the life of the bearings. All oil impregnated bearings used receive their lubrication from the grease in the gear case. Clean and re-lubricate gear case yearly or whenever servicing requires the gear case to be removed. Use type and quantity of grease shown on Parts Bulletin packed with your tool.

Gear case is removed by removing the three screws from the front of the tool. If the chuck is too large to permit removal of the two top screws, see instructions for chuck removal.

IMPORTANT

To assure product SAFETY and RELIABILITY, repairs, maintenance and adjustment, (including brush inspection and replacement) should be performed by Black & Decker Service Centers or other qualified service organizations, always using Black & Decker replacement parts.

COMMERCIAL/INDUSTRIAL USE WARRANTY

Black & Decker warrants this product for one year from date of purchase. We will repair without charge, any defects due to faulty material or workmanship. Please return the complete unit, transportation prepaid, to any Black & Decker Service Center or Authorized Service Station listed under "Tools Electric" in the yellow pages. This warranty does not apply to accessories or damage caused where repairs have been made or attempted by others.

Black & Decker® and  are registered trademarks of The Black and Decker Manufacturing Company, Towson, Maryland, U.S.A.

BLACK & DECKER (U.S.) INC., TOWSON, MD. 21204, U.S.A.

Form No. 724108-01

(FEB80-CD)

Printed in U.S.A.

Free Manuals Download Website

<http://myh66.com>

<http://usermanuals.us>

<http://www.somanuals.com>

<http://www.4manuals.cc>

<http://www.manual-lib.com>

<http://www.404manual.com>

<http://www.luxmanual.com>

<http://aubethermostatmanual.com>

Golf course search by state

<http://golfingnear.com>

Email search by domain

<http://emailbydomain.com>

Auto manuals search

<http://auto.somanuals.com>

TV manuals search

<http://tv.somanuals.com>