



Residential Ultra Low NOx High Efficiency Energy Saver Gas Water Heater



Photo is of
U4-5036FRN

Identical Dimensions

Same diameter, height and connections as standard units for ease of installation.

The FVIR Eco-Defender Safety System® Models Feature:

- **Defender Combustion Chamber**—Incorporates the Advanced ScreenLok® Technology Flame Arrestor and large split-door design to prevent ignition of flammable vapors outside the water heater.
- **Ultra Low NOx Burner with Primary and Secondary Air Distribution Devices**—Ensures proper air to gas ratio for reduction of NOx generated by the combustion process.
- **Digital Thermal Sensor and Resettable Thermal Switch**—Coordinates with self diagnostic control to prevent water heater operation as needed.
- **Millivolt Powered Control with Built-in Piezo Igniter**—Easy and quick lighting of the pilot burner by push button.
- **Pedestal Base**—Rugged and durable base allows easy transport and positioning, and corrosion resistant contact with floor.
- **Maintenance Free**—No regular cleaning of air inlet openings or flame arrestor is required under normal conditions.
- **Sight Window**—Offers a view into the combustion chamber to observe the operation of the pilot and burner.
- **No Electricity Required.**
- **Factory Installed Hydrojet® Total Performance System**—Cold water inlet sediment reducing device helps prevent sediment build up in tank. Increases first hour delivery of hot water while minimizing temperature build up in tank.
- **Vitraglas® Lining**—Bradford White water heater tanks are protected from the corrosive effects of hot water by an exclusive ceramic porcelain-like coating.
- **Self Diagnostic Honeywell Gas Control**—Integrated, immersion gas control learns and monitors the combustion chamber's temperature profile and prevents water heater operation during upset conditions. Also equipped with an LED display to aid in start-up and diagnostics.
- **2" Non-CFC Foam Insulation**—Surrounds the tank surface, saving energy by retarding loss of heat.
- **Water Connections**—3/4" NPT factory installed true dielectric fittings extend water heater life and eases installation.
- **Factory Installed Heat Traps**—Design incorporates a flexible disk that reduces heat loss in piping and eliminates the potential for noise generation.
- **Protective Magnesium Anode Rod**—Provides added protection against corrosion for long trouble-free service.
- **3x4 "Snap Lock" Draft Diverter**—Allows either 3" or 4" vent connections with inputs of 40,000 BTU/Hr. or less.
- **Flue Baffle**—Maximizes the amount of heat absorbed by the tank and reduces heat loss during standby periods.
- **Steel Tank**—Heavy gauge steel automatically formed, rolled and welded.
- **T&P Relief Valve**—Included.
- **Brass Drain Valve.**
- **Meets C.E.C. Title 24, and SCAQMD Rule 1121 (10ng/J NOx limit).**
- **Design Certified by CSA International (formerly AGA/CGA).**
- **Minimum Energy Factor of 0.62.**



6 or 10-Year Limited Tank Warranties / 6-Year Limited Warranty on Component Parts.

For more information on warranty, please visit www.bradfordwhite.com

For products installed in USA, Canada and Puerto Rico. Some states do not allow limitations on warranties. See complete copy of the warranty included with the heater.

Bradford White received the highest numerical score among water heater/boiler manufacturers in the proprietary J.D. Power and Associates/ McGraw-Hill Construction 2006 HVAC and Water Heater/Boiler Subcontractor Satisfaction Study™. Study based on 882 responses measuring 3 water heater/boiler manufacturers and measures opinions of subcontractors. Proprietary study results are based on experiences and perceptions of subcontractors surveyed in May through July 2006. Your experiences may vary. Visit jdpower.com

MANUFACTURED UNDER ONE OR MORE OF THE FOLLOWING U.S. PATENTS: 7,063,133 B2; 5,954,492; 5,761,379; 5,943,984; 5,081,696; 5,988,117; 6,142,216; 5,199,385; 5,574,822; 5,372,185; 5,485,879; 5,277,171; (B1)5,341,770; 5,660,165; 5,596,952; 5,682,666; 4,904,428; 5,023,031; 5,000,893; 4,669,448; 4,829,983; 4,808,356; 5,115,767; 5,092,519; 5,052,346; 4,416,222; 4,628,184; 4,861,968; 4,672,919; Re. 34,534. OTHER U.S. AND FOREIGN PATENT APPLICATIONS PENDING. CURRENT CANADIAN PATENTS: 1,272,914; 1,280,043; 1,289,832; 2,045,862; 2,112,515; 2,108,186; 2,107,012; 2,092,105.. Defender Safety System®, ScreenLok®, Vitraglas® and Hydrojet® are registered trademarks of Bradford White® Corporation.



High Efficiency Ultra Low NOx Energy Saver Models

NATURAL GAS

Meet or exceed ASHRAE 90.1b (current standard) C.E.C. Listed
Recovery efficiency ranging up to 80%

Model Number	Capacity		Nat. BTU/Hr. Input	Recovery at 90°F Rise*		A Floor to Flue Conn. in.	B Jacket Dia. in.	C Vent Size in.	D Floor to T&P Conn. in.	E Floor to Gas Conn. in.	H Floor to Water Conn. in.	K Depth in.	Approx. Shipping Weight lbs.
	U.S. Gal.	Imp. Gal.		Nat. U.S. GPH	Nat. Imp. GPH								
U4-30T6FRN•	30	25	32,000	34	28	59 ¹ / ₈	18	3x4	49 ³ / ₄ / 56 ³ / ₈	13	57 ¹ / ₂	22 ¹ / ₄	123
U4-40T6FRN•	40	33	40,000	43	36	59 ³ / ₈	20	3x4	50 / 56 ³ / ₈	13	57 ³ / ₄	24 ¹ / ₄	137
U4-40S6FRN•	40	33	40,000	43	36	50	22	3x4	41 / 47 ¹ / ₄	13	48 ¹ / ₂	26 ¹ / ₄	143
U4-50S6FRN•	50	42	40,000	43	36	59 ³ / ₈	22	3x4	50 / 57	13	58	26 ¹ / ₄	160

Model Number	Capacity		Nat. kW Input	Recovery at 50°C Rise*	A Floor to Flue Conn. mm.	B Jacket Dia. mm.	C Vent Size mm.	D Floor to T&P Conn. mm.	E Floor to Gas Conn. mm.	H Floor to Water Conn. mm.	K Depth mm.	Approx. Shipping Weight kg.
	Liters											
U4-30T6FRN•	114		9.4	129	1502	457	76x102	1264/1432	330	1460	565	56
U4-40T6FRN•	151		11.7	163	1508	508	76x102	1270/1438	330	1467	615	62
U4-40S6FRN•	151		11.7	163	1270	559	76x102	1041/1200	330	1232	666	65
U4-50S6FRN•	189		11.7	163	1514	559	76x102	1270/1448	330	1473	666	73

Available in Natural Gas only.

For 10 year models, change suffix from "6" to "10".

*Based on manufacturers rated recovery efficiency.

•Models feature optional top T&P location and must be specified when ordering.

All models meet SCAQMD rule 1121 requirement of 10ng/J, or less, NOx emissions.

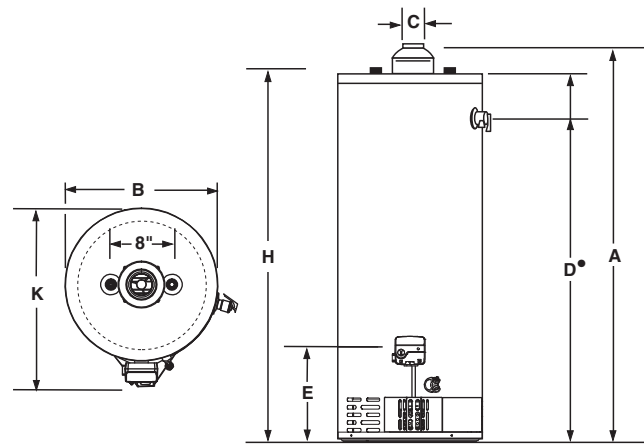

• Optional T&P Location Dimension "D" dimension listed as side/top.

Meets NAECA Requirements

General

All gas water heaters are certified at 300 PSI test pressure (2068 kPa) and 150 PSI working pressure (1034 kPa). All water connections are 3/4" NPT (19mm) on 8" (203mm) centers. All gas connections are 1/2" (13mm).

All models design certified by CSA International (formerly AGA/CGA), to meet ANSI standard Z-21.10.1 and peak performance rated.

Dimensions and specifications subject to change without notice in accordance with our policy of continuous product improvement.

Suitable for Water (Potable) Heating and Space Heating.

Toxic chemicals, such as those used for boiler treatment, shall NEVER be introduced into this system. This unit may NEVER be connected to any existing heating system or component(s) previously used with a non-potable water heating appliance.



For U.S. and Canada field service, contact your professional installer or local Bradford White sales representative.

Sales 800-523-2931 • Fax 215-641-1670 / Technical Support 800-334-3393 • Fax 269-795-1089 • Warranty 800-531-2111 • Fax 269-795-1089

International: Telephone 215-641-9400 • Telefax 215-641-9750 / www.bradfordwhite.com

BRADFORD WHITE-CANADA INC. Sales / Technical Support 866-690-0961 / 905-238-0100 • Fax 905-238-0105 / www.bradfordwhite.com

Built to be the Best™

©2007, Bradford White Corporation. All rights reserved.

Free Manuals Download Website

<http://myh66.com>

<http://usermanuals.us>

<http://www.somanuals.com>

<http://www.4manuals.cc>

<http://www.manual-lib.com>

<http://www.404manual.com>

<http://www.luxmanual.com>

<http://aubethermostatmanual.com>

Golf course search by state

<http://golfingnear.com>

Email search by domain

<http://emailbydomain.com>

Auto manuals search

<http://auto.somanuals.com>

TV manuals search

<http://tv.somanuals.com>