

bravetti®

16 LITER CONVECTION TOASTER OVEN

OWNER'S MANUAL

Model: TO160H
120V., 60Hz., 1380 Watts



IMPORTANT SAFETY INSTRUCTIONS

When using your **Convection Toaster Oven**, basic safety precautions should always be observed, including the following:

1. Read all instructions before using your **Convection Toaster Oven**.
2. Do not touch hot surfaces. Always use handles or knobs.
3. Close supervision is necessary when any appliance is used by or near children.
4. To protect against electric shock, do not immerse cord, plug or any parts of the oven in water or any other liquids.
5. Do not let cord hang over edge of table or counter, or touch hot surfaces.
6. Do not operate appliance with damaged cord or plug or after the appliance malfunctions or has been damaged in any manner. Return appliance to the nearest **EURO-PRO Operating LLC** for examination, repair or adjustment.
7. The use of accessory attachments not recommended by the appliance manufacturer may cause hazard or injury.
8. Do not place on or near a hot gas or electric burner.
9. When operating the oven, keep at least four inches of free space on all sides of the oven to allow for adequate air circulation.
10. Unplug from outlet when not in use and before cleaning. Allow to cool before putting on or taking off parts, and before cleaning.
11. To disconnect, turn the time control button to OFF, then remove the plug. Always hold the plug, and never pull the cord.
12. Extreme caution must be used when moving a drip pan containing hot oil or other hot liquids.
13. Do not cover crumb tray or any part of the oven with metal foil. This may cause the oven to overheat.
14. Use extreme caution when removing the tray, racks or disposing of hot grease or other hot liquids.
15. Do not clean the inside of the oven with metal scouring pads. Pieces can break off the pad and touch electrical parts, creating a risk of electric shock.
16. Oversized foods or metal utensils must not be inserted in a toaster oven as they may create a fire or risk of electric shock.
17. A fire may occur if the oven is covered or touching flammable material, including curtains, draperies, walls and the like when in operation. Do not place any items on the oven during operation.
18. Extreme caution should be exercised when using cooking or baking containers constructed of anything other than metal or ovenproof glass.
19. Be sure that nothing touches the top or bottom elements of the oven.
20. Do not place any of the following materials in the oven: cardboard, plastic, paper, or anything similar.
21. Do not store any materials other than manufacturer's recommended accessories in this oven when not in use.
22. This appliance is OFF when the Timer Control button is in the "OFF" position.
23. Always wear protective, insulated oven gloves when inserting or removing items from the hot oven.
24. This appliance has a tempered, safety glass door. The glass is stronger than ordinary glass and more resistant to breakage. Tempered glass can still break around the edges. Avoid scratching door surface or nicking edges.
25. Do not use outdoors.
26. Do not use appliance for other than intended use.
This unit has a short power supply cord to reduce the risk resulting from becoming entangled in or tripping over a long cord. An extension cord may be used if you are careful in its use:
 1. The electrical rating of the extension cord should be at least as great as the electrical rating of the appliance.
 2. An extension cord with the power cord must be arranged so that it will not drape over the countertop or tabletop where they can be pulled on by children or tripped over accidentally.

SAVE THESE INSTRUCTIONS For Household Use Only

WARNING: To reduce the risk of electric shock, this appliance has a polarized plug (one blade is wider than the other). This plug will fit in a polarized outlet only one way. If the plug does not fit fully in the outlet, reverse the plug. If it still does not fit, contact a qualified electrician to install the proper outlet. Do not modify the plug in any way.

GETTING TO KNOW YOUR CONVECTION TOASTER OVEN

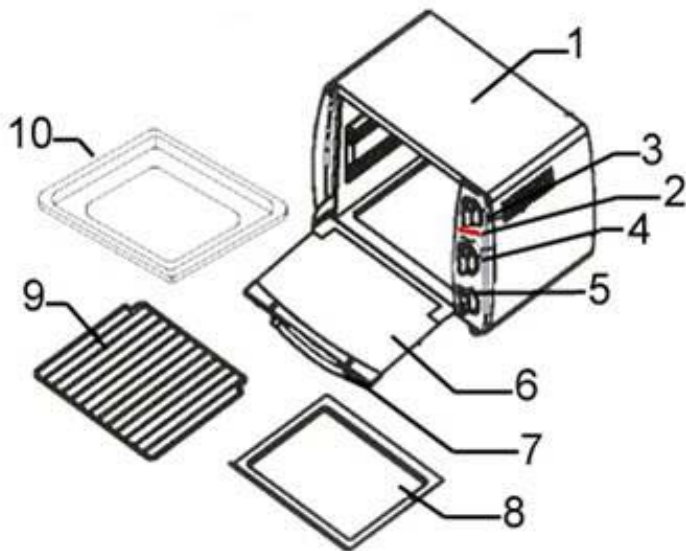

- | | |
|------------------------------|---------------------------|
| 1. Exterior Casing | 7. Cool Touch Door Handle |
| 2. Power on Light | 8. Crumb Tray |
| 3. Temperature Control Knob | 9. Wire Rack (x2) |
| 4. Function Control Knob | 10. Bake Pan |
| 5. On/Off Timer Control Knob | |
| 6. Tempered Glass Door | |

CONTROL PANEL

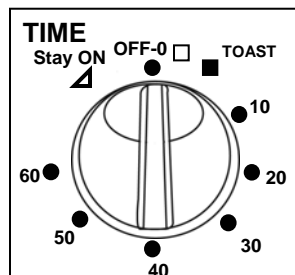
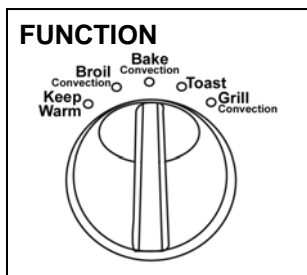
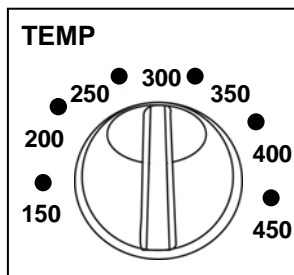

Technical Specifications

Voltage: 120V., 60Hz.
Power: 1380 Watts

Read all the sections of this booklet and follow all the instructions carefully.

Before Using Your Convection Toaster Oven

1. Read all of the instructions included in this manual.
2. Make sure that the oven is unplugged and the Time Control is in the "OFF" position.
3. Wash all the accessories in hot, soapy water or in the dishwasher.
4. Thoroughly dry all accessories and re-assemble in oven. Plug oven into outlet and you are ready to use your new Toaster Oven with Convection.
5. After re-assembling your oven, we recommend that you run it at the highest temperature (450° F.) on the Toast Function for approximately 15 minutes to eliminate any packing residue that may remain after shipping. This will also remove all traces of odor initially present.

Please Note: Initial start-up operation may result in minimal smell and smoke (about 15 minutes). This is normal and harmless. It is due to burning of the protective substance applied to the heating elements in the factory.

Convection Cooking

Convection cooking combines hot air movement by means of a fan with the regular features (broil, bake and toast). Convection cooking provides faster cooking in many cases than regular radiant types toaster ovens. The fan gently sends air to every area of the food, quickly browning, crisping and sealing in moisture and flavor. It produces more even temperature all around the food by air movement, so that food cooks/bakes/broils evenly versus the normal ovens hot and cold spots. The convection feature allows cooking/baking at lower temperatures, which saves energy and helps keep the kitchen cooler. Convection air is superheated and it circulates around the food so it cooks food significantly faster than conventional ovens.

Using Your Convection Toaster Oven

Please familiarize yourself with the following oven functions and accessories prior to first use:

- **Temperature Control** - Choose the desired temperature from **150° to 450° F** for baking, broiling, toasting or grilling.
- **Function Control** - This oven is equipped with five positions for a variety of cooking needs:
 - Bake w/Convection** - Cakes, pies, cookies, poultry, beef, pork, etc.
 - Toast** - Bread, muffins, frozen waffles, etc.
 - Grill w/Convection** - For grilling fish, steak, sandwiches, bacon & eggs, etc.
 - Broil w/ Convection** - For broiling fish, steak, poultry, pork chops, etc.
 - Keep Warm** - To keep cooked food warm for up to **30 minutes**.
- **Time Control** - When you turn the control to the left, (counter-clockwise), the oven will "STAY ON" until it is manually shut "OFF". To activate the timer segment of the control, turn to the right (clockwise) to toast or use as a timer. This function also has a bell that rings at the end of the programmed time.
- **Convection Fan** - The convection fan works automatically on Broil, Bake and Grill settings.
- **Power "On" Light** - It is illuminated whenever the oven is turned on.
- **Bake Pan** - For use in broiling and roasting meat, poultry, fish and various other foods.

Using Your Convection Toaster Oven

WARNING: TO AVOID RISK OF INJURY OR BURNS, DO NOT TOUCH HOT SURFACES WHEN OVEN IS IN USE. ALWAYS USE OVEN MITTS.

CAUTION: Always use extreme care when removing bake pan, wire rack or any hot container from a hot oven. Always use an oven mitt when removing hot items from the oven.

Broiling with Convection

The top heating elements cycle on and off to maintain maximum temperature in the oven. For best results, the oven should be preheated for 20 minutes at 450°F before adding the food to be broiled. In the convection oven, it is not necessary to turn the food because the fan circulates the hot air around the food. The food must be placed on the wire rack with the broil pan in position to catch the drippings and allow the circulation of air.

Operation

- Set Temperature Control to **450°F**.
- Turn Function Control to **Broil/Convection**.
- Preheat the oven.
- Place the Bake pan on lowest rack support.
- Place the food on the Wire Rack and slide into the Top Rack Support Guide or Middle Rack Support Guide depending on the thickness of the food that you are cooking.
- Food should be placed as close as possible to the Top Heating Element without touching it.
- Set temperature control to the appropriate temperature.
- Brush food with sauces or oil, as desired.
- Turn Time Control to position "**Stay On**".
- It is advisable to leave the door **slightly ajar**.
- When broiling is complete, turn the Time Control to "**OFF**".

Broiling Guide

Cooking results may vary, adjust these times to your individual requirements. Also, check often during broiling to avoid overcooking.

| MEAT | OVEN TEMP | COOKING TIME |
|---------------|-----------|--------------|
| RIB STEAK | 400 | 20-25 min. |
| T-BONE STEAK | 400 | 20-25 min. |
| HAMBURGER | 400 | 15-20 min. |
| PORK CHOPS | 400 | 20-25 min. |
| LAMB CHOPS | 400 | 20-25 min. |
| CHICKEN LEGS | 400 | 30-35 min. |
| FISH FILETS | 350 | 20-25 min. |
| SALMON STEAKS | 350 | 20-25 min. |

Note: All broiling times are based on meats at refrigerator temperature. Frozen meats may take considerably longer. Therefore, use of a meat thermometer is highly recommended.

Baking with Convection

Convection baking is very consistent and even. The fan circulates the hot air around the food making baked goods rise quickly and evenly. Bake your favorite cookies, cakes, pies, brownies, etc. The bake ware that will fit in your oven are up to 11 inches in length. We do not recommend the use of oven roasting bags or glass containers in the oven. **Never** use plastic, cardboard, paper or anything similar in the oven.

Note: Position the wire rack in the lowest Support Guide.

Operation

- Place the wire rack in the **lowest or middle** Rack Support Guide depending on the height of the pan or according to the recipe.
- Place pan with item(s) to be baked on the wire rack.
- Turn the Function Control to **Bake/Convection**.
- Turn the Time Control to position “**Stay On**”.
- When baking is complete, turn the Time Control to “**OFF**”.

Positioning of the Wire Rack

Cookies - Use bottom and middle Support Guides.

Layer Cakes - Use bottom Support Guide only (bake one at a time).

Pies - Use bottom Support Guide.

Baking Cookies

For baking cookies, we suggest adjusting baking temperature and using a cookie sheet placed on the wire rack. Also, using parchment paper on a cookie sheet might prove helpful when baking certain types of cookies.

1. Pre-heat oven for 15 minutes, then place cookie sheets on the wire rack to begin baking.
2. Use parchment paper on cookie sheet so cookies will not stick.
3. Cookie sheets, baking times and temperatures may differ from those necessary when using other baking materials.

Note: Convection air is superheated and it circulates around the food, so it cooks food faster. When baking your favorite recipes or packaged goods, follow recipe instructions. Check the baked goods a few minutes before the shortest recommended baking time.

Baking Guide

Follow the package or recipe instructions for baking times and temperature.

Recommended Pan Sizes

The following recommended pan sizes should fit your Convection / Toaster Oven. To be sure pan will fit place the pan inside the oven to check before preparing your recipe.

- 6-cup muffin pan
- 8 x 4 loaf pan
- 9 x 5 loaf pan
- 8" round or square baking pan or dish
- 1-11/2 quart casserole dish – most types.

When baking in loaf pans, we recommend you do not fill more than half full.

Toasting

Large capacity oven allows for toasting 4 to 6 slices of bread, 6 muffins, frozen waffles or frozen pancakes. When toasting only 1 or 2 items, place food on the Wire Rack in the center of the oven.

Operation

- Set the Temperature Control to 450°F.
- Turn the Function Control to **Toast**.
- Place food to be toasted on the Wire Rack.
- Ensure Crumb Tray is in place.
- Turn the Time Control to desired time. (See suggested toast settings below).
- Bell will ring to signal the end of the Toast cycle.

Note: Wire Rack should be positioned in the middle of the oven with the indentations pointing down.

Suggested Toast Settings:

| | |
|---------|--------|
| Light: | 4 min. |
| Medium: | 5 min. |
| Dark: | 7 min. |

CAUTION: When toasting, do not leave food in for longer periods of time other than what is listed above. Toasting for longer than recommended times will burn food.

Grilling with Convection

For best results, it is recommended that you preheat the oven for 15 minutes on 450°F before adding the food to be grilled. In the convection oven, it is not necessary to turn the food because the fan circulates the hot air around the food.

Operation

- Set Temperature Control to 450°F.
- Turn Function Control to Grill w/Convection.
- Preheat the oven for 15 minutes.
- Place the bake pan on the lowest rack support.
- Place the food on the Wire Rack and slide into the Top Rack Support Guide or Middle Rack Support Guide depending on the thickness of the food that you are cooking.
- Food should be placed as close as possible to the Top Heating Element without touching it.
- Set temperature control to the appropriate temperature.
- Brush food with sauces or oil, as desired.
- Turn Time Control to position ‘Stay On’.
- It is advisable to leave the door slightly ajar.
- When grilling is complete, turn the Time Control to ‘OFF’.

Keep Warm

Keep cooked food warm for up to 30 minutes. Longer periods of time are not recommended as food will become dry or will spoil.

Operation

- Set the Temperature Control to 180°F.
- Turn the Function Control to Keep Warm.
- Turn the Time Control to "Stay On" position.
- Turn the Time Control to "Off" position when finished with Keep Warm.

Caution: When sliding trays out of oven, always support the rack. Do not let go until you are sure the rack is securely supported.

Care & Cleaning

Warning: Be sure to unplug the oven and allow it to cool before cleaning.

To assure maximum safe operation, keep your toaster oven free of grease and build-up of food particles. Clean the inside of the walls with a damp sponge, cloth or nylon scouring pad and mild detergent. **DO NOT USE STEEL WOOL SCOURING PADS, ABRASIVE CLEANERS OR SCRAPE THE WALLS WITH A METAL UTENSIL, AS ALL OF THESE METHODS MAY DAMAGE THE FINISH.**

All accessories should be washed in hot soapy water or can be cleaned in a dishwasher. The door can be wiped with a damp sponge and wiped dry with a paper or cloth towel. Clean the outside with a damp sponge.

DO NOT USE AN ABRASIVE CLEANER AS IT MAY DAMAGE THE EXTERIOR FINISH.

DO NOT USE AN ABRASIVE CLEANER OR STEEL WOOL SCOURING PAD ON THE BAKE PAN AS IT MAY DAMAGE THE PORCELAIN ENAMEL FINISH.

LET ALL PARTS AND SURFACES DRY THOROUGHLY PRIOR TO PLUGGING OVEN IN AND USING.

Model
TO160H

EURO-PRO

ONE (1) YEAR LIMITED WARRANTY

EURO-PRO Operating LLC warrants this product to be free from defects in material and workmanship for a period of one (1) year from the date of the original purchase, when utilized for normal household use, subject to the following conditions, exclusions and exceptions.

If your appliance fails to operate properly while in use under normal household conditions within the warranty period, return the complete appliance and accessories. For Customer Service support, call 1 (800) 798-7398 or visit our website www.euro-pro.com.

If the appliance is found by **EURO-PRO** to be defective in material or workmanship, **EURO-PRO** will repair or replace it free of charge. Proof of purchase date and \$ 16.95 to cover the cost of return shipping and handling must be included. *

The liability of **EURO-PRO Operating LLC** is limited solely to the cost of the repair or replacement of the unit at our option. This warranty does not cover normal wear of parts and does not apply to any unit that has been tampered with or used for commercial purposes. This limited warranty does not cover damage caused by misuse, abuse, negligent handling or damage due to faulty packaging or mishandling in transit. This warranty does not cover damage or defects caused by or resulting from damages from shipping or repairs, service or alterations to the product or any of its parts, which have been performed by a repair person not authorized by **EURO-PRO**.

This warranty is extended to the original purchaser of the unit and excludes all other legal and/or conventional warranties. The responsibility of **EURO-PRO Operating LLC** if any, is limited to the specific obligations expressly assumed by it under the terms of the limited warranty. **In no event is EURO-PRO Operating LLC** liable for incidental or consequential damages of any nature whatsoever. Some states/provinces do not permit the exclusion or limitation of incidental or consequential damages, so the above may not apply to you.

This warranty gives you specific legal rights, and you may also have other rights which vary from state to state or province to province.

***Important:** Carefully pack item to avoid damage in shipping. Be sure to include proof of purchase date and to attach tag to item before packing with your name, complete address and phone number with a note giving purchase information, model number and what you believe is the problem with item. We recommend you insure the package (as damage in shipping is not covered by your warranty). Mark the outside of your package "ATTENTION CUSTOMER SERVICE". We are constantly striving to improve our products, therefore the specifications contained herein are subject to change without notice.



PRODUCT REGISTRATION CARD

Please complete and return within ten (10) days of purchase. The registration will enable us to contact you in the event a product defect is discovered. By returning this card you acknowledge to have read and understood the instructions for use, and warnings set forth in the accompanying instructions.

RETURN TO: **EURO-PRO Operating LLC**, 94 Main Mill street, Door 16, Plattsburgh, NY, 12901

TO160H

Appliance Model

Date of Purchase

Name of store

Owner's name

Address

City

Prov.

Postal Code

Free Manuals Download Website

<http://myh66.com>

<http://usermanuals.us>

<http://www.somanuals.com>

<http://www.4manuals.cc>

<http://www.manual-lib.com>

<http://www.404manual.com>

<http://www.luxmanual.com>

<http://aubethermostatmanual.com>

Golf course search by state

<http://golfingnear.com>

Email search by domain

<http://emailbydomain.com>

Auto manuals search

<http://auto.somanuals.com>

TV manuals search

<http://tv.somanuals.com>