

SINCE 1839

BRINLY

SINCE 1839

BRINLY

OWNER'S MANUAL

TOW CART

MODEL:

HDC-10L BH

HDC-16L BH

- Assembly
- Installation
- Operation
- Repair Parts

For use with Riders
and Lawn/Garden Tractors

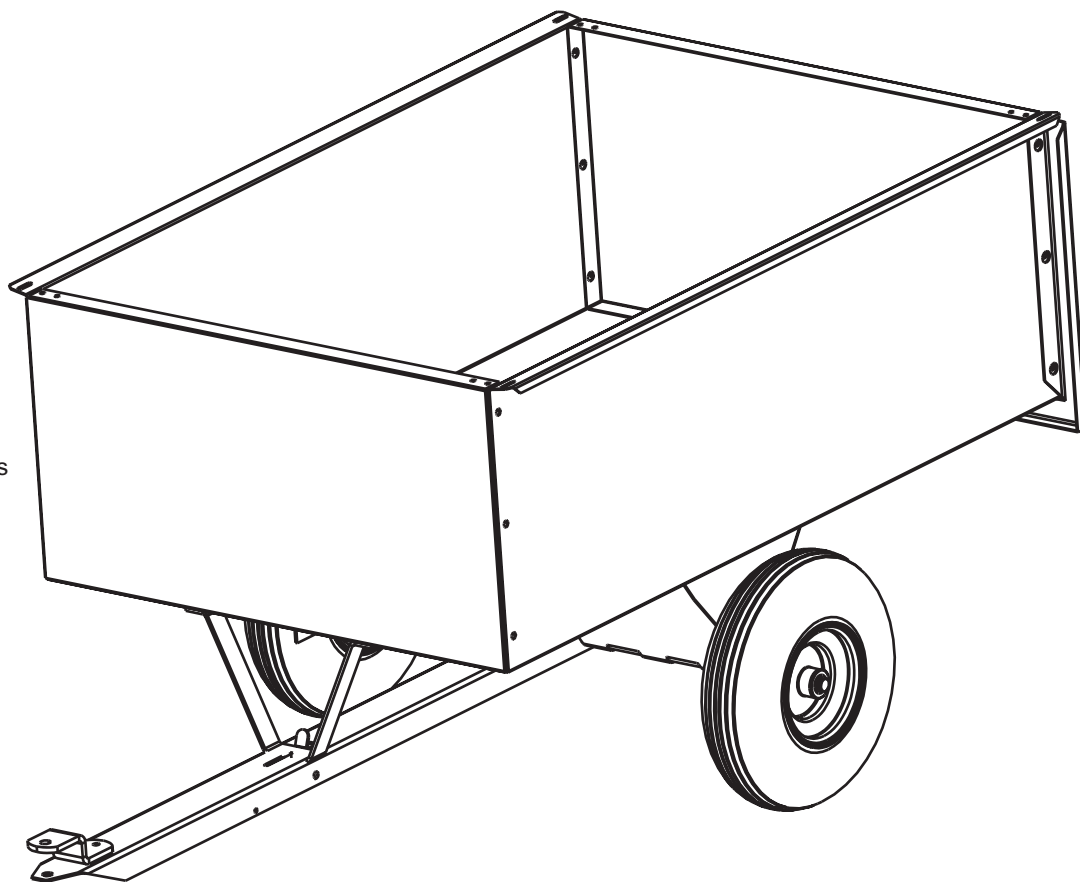

HDC-16L Shown

For the latest product updates and setup tips:

Visit us on the web!
www.brinly.com

Important: This manual contains information for the safety of persons and property. Read it carefully before assembly and operation of the equipment!

L-1783-BH-01

CONGRATULATIONS on your new Brinly-Hardy Cart! Your Cart has been designed, engineered and manufactured to give you the best possible dependability and performance.

Should you experience any problem you can not easily remedy, please do not hesitate to contact our knowledgeable customer service department toll-free at 1-877-728-8224. We have competent, well trained technicians.

Please read and retain this manual. The instructions will enable you to assemble and maintain your cart properly. And please, always observe the "Safety Rules".

CUSTOMER RESPONSIBILITIES _____

Read and Observe the "Safety Rules".

Follow a regular schedule in maintaining, caring-for and using your Brinly-Hardy Cart.

TABLE OF CONTENTS _____

SAFETY RULES	2
HARDWARE.....	3
PARTS REFERENCE	4
EXPLODED REFERENCE.....	5
ASSEMBLY	6-7
MAINTENANCE.....	8
OPERATION.....	8
PRODUCTS.....	11
WARRANTY.....	11

RULES FOR SAFE OPERATION _____

- Know controls and how to stop quickly, READ THE OWNER'S MANUAL.
- Do not allow children to operate the vehicle, do not allow adults to operate without proper instruction or without having read the owner's manual.
- Do not carry passengers. Keep children and pets a safe distance away.
- Always wear substantial footwear. Do not wear loose fitting clothing that can get caught in moving parts.
- Keep your eyes and mind on your tractor/attachment and area being covered. Do not let other interests distract you.
- Stay alert for holes in the terrain and other hidden hazards.
- Do not drive close to creeks, ditches and public highways.
- Watch out for traffic when crossing or near roadways.
- When using any attachment, don't allow anyone near the vehicle while in operation.

- Keep the vehicle and attachment in good operating condition and keep safety devices in place.
- Keep all nuts, bolts and screws tight to be sure the equipment is in safe working condition.
- The vehicle and attachment should be stopped and inspected for damage after striking a foreign object. The damage should be repaired before restarting and operating the equipment.
- See tractor equipment owner's manual for safe operation of the equipment.
- Use correct number of weights on tractor. The weight of the tractor and operator **MUST BE MORE** than the weight of the cart and load.
- When backing - carefully back straight to avoid jack knifing, which could result in damage to equipment.
- Maximum load is 650 lbs for HDC-10L and 1200 for HDC-16L.
- **DO NOT** tow this cart behind a motor vehicle.(Car, Truck, ATV) Max speed 5 mph.
- Maintain cart tires inflated to 30 psi.



OPERATING HINTS _____

To Dump load:

1. Stop the tractor, lock the parking brake and stop the engine.
2. Release the lock bar and raise the handle carefully to tilt the bed to the full dump position.



This symbol will help to point out important safety precautions throughout this manual. It means - ATTENTION! BECOME ALERT! Your safety is involved.

HARDWARE REFERENCE

Tools Required for Assembly:

- * Set of open-end wrenches (1)**
- * Pliers**
- * Flat Head Screwdriver**
- * 3/16" Allen Wrench(1)**
- * Adjustable Wrench (1)**

Parts Reference

Parts List

REF. NO.	PART NO.	QTY.	PART NO.	QTY.	DESCRIPTION
	HDC-10L		HDC-16L		
1	B-1675P	1	B-1675P	1	Hex Lock Nut, 3/8"
2	B-3034-10	1	B-3034-10	1	Clevis
3	B-5363-10	2	B-5444-10	2	End Panel, F/R
4	B-3301-10	1	B-3301-10	1	Lock Bar (Handle)
5	B-3303	1	B-3303	1	Handle Spring
6	B-3305	2	B-3305	2	Handle Spacer
7	B-5455-01	2	B-5455-01	2	Gate Lock Bracket
8	B-3307	2	B-3307	2	Gate Retainer Pin
9	B-4599-10	1	B-3308-10	1	Axle Support Bracket
10	B-4261	1	B-4261	1	Axle
11	B-5370-10	1	B-3411A-10	1	Drawbar
12	B-5364-10	1	B-5445-10	1	Support Channel
13	B-3520-10	1	B-3520-10	1	Lock Bracket
14	B-5482	1	B-5482	1	Caution Decal
15	B-5369-10	2	B-5443-10	2	Bed Half, R/L
16	B-5372	2	B-6116	2	Wheel
17	R-618	8	R-618	10	Special Washer
18	1M1256P	1	1M1256P	1	Hex Head Bolt, 3/8" x 3-1/2"
19	20M0808P	4	20M0808P	4	Round Head Screw, 1/4" x 1/2"
20	20M1008P	10	20M1008P	14	Round Head Screw, 5/16" x 1/2"
21	20M1012P	2	20M1012P	2	Round Head Screw, 5/16" x 3/4"
22	26M1012P	16	26M1012P	18	Flat Head Screw, 5/16" x 3/4"
23	B-4785	4	B-4785	4	Nylon Insert Nut, 1/4"
24	B-4786	33	B-4786	38	Nylon Insert Nut, 5/16"
26	40M1000P	2	40M1000P	2	Lock Washer, 5/16"
27	B-5794	4	B-5606	4	Flat Washer, 3/4"
28	B-4305	2	B-4305	2	"E"-Ring, 3/4"
29	B-5924	1	B-5924	1	Logo Decal
30	D-146P	1	D-146P	1	Hairpin Cotter, 1/8"
31	45M2121P	8	45M2121P	8	Flat Washer, 5/8"
32	B-3861	1	B-3861	1	Drawbar Pin, 1/2" x 2-1/4"
33	20M1016P	2	20M1016P	2	Round Head Screw, 5/16" x 1"

To Order Parts Call:
877-728-8224

Visit us on the web:
www.brinly.com



EXPLODED REFERENCE

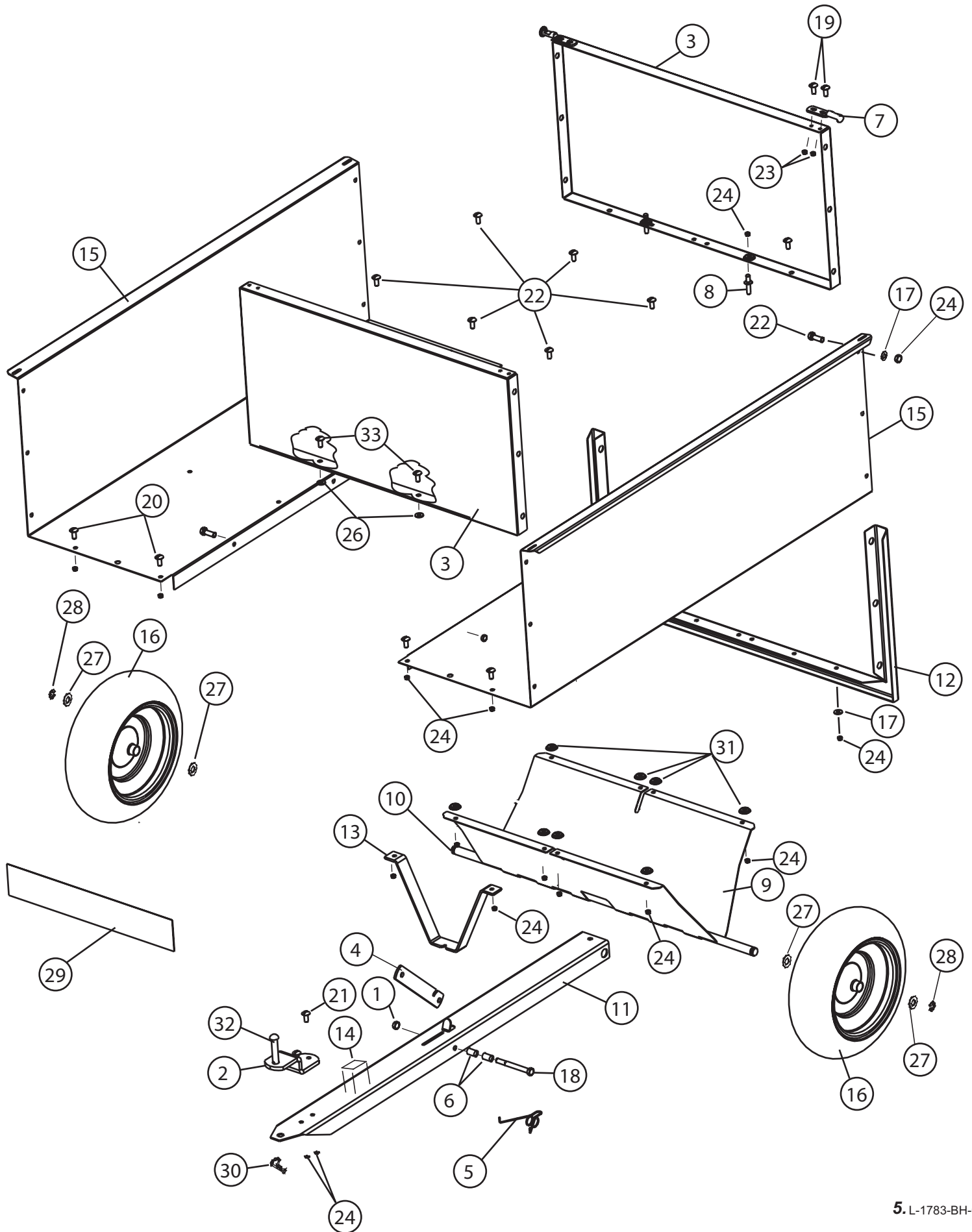

Step 1.

NOTE: HDC-16L Shown throughout manual.

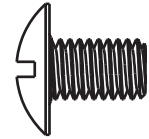
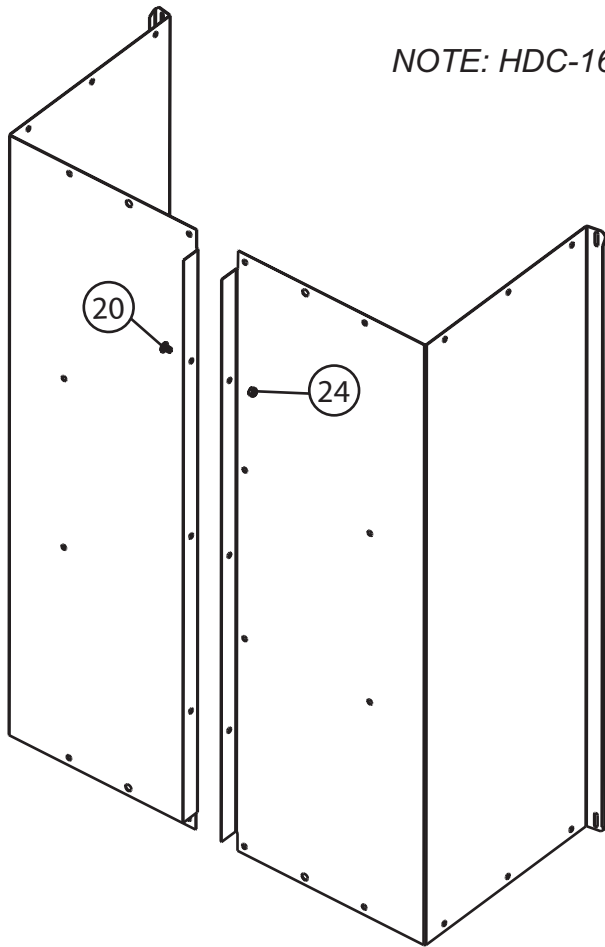

20
Hex Bolt, 5/16" x 1/2"
Qty. 3



24
Hex Nut
Qty. 3

Step 2.

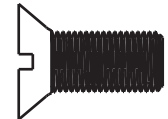
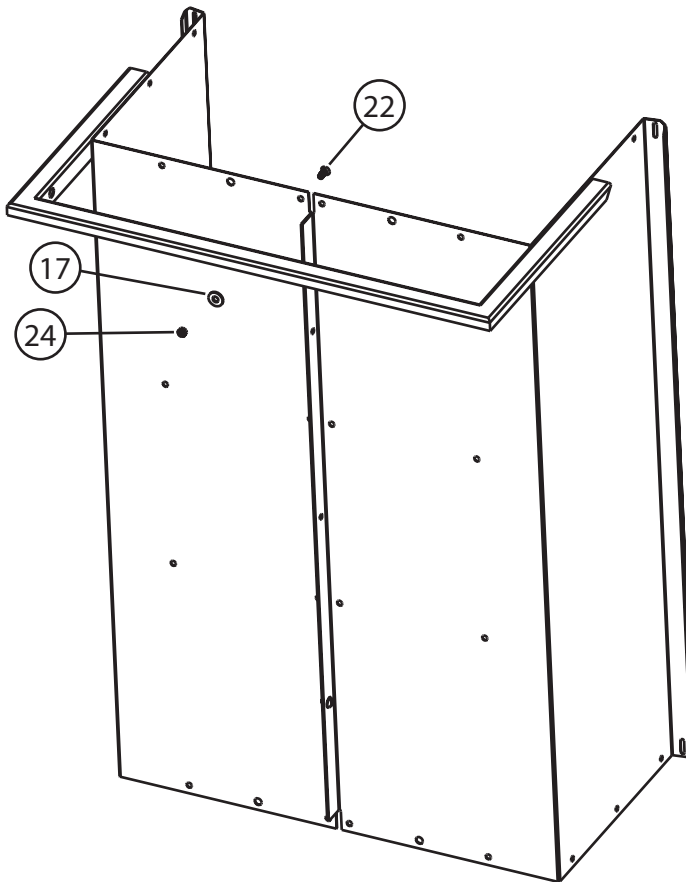

22
Flat Head Screw, 5/16" x 3/4"
Qty. 10



24
Hex Lock Nut
Qty. 10

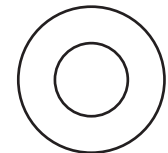

17
Special Washer
Qty. 10

Step 3.

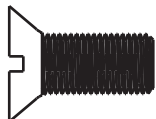

22
Flat Head Screw, 5/16" x 3/4"
Qty. 8



24
Hex Lock Nut
Qty. 8

31
5/8" Flat Washer
Qty. 8

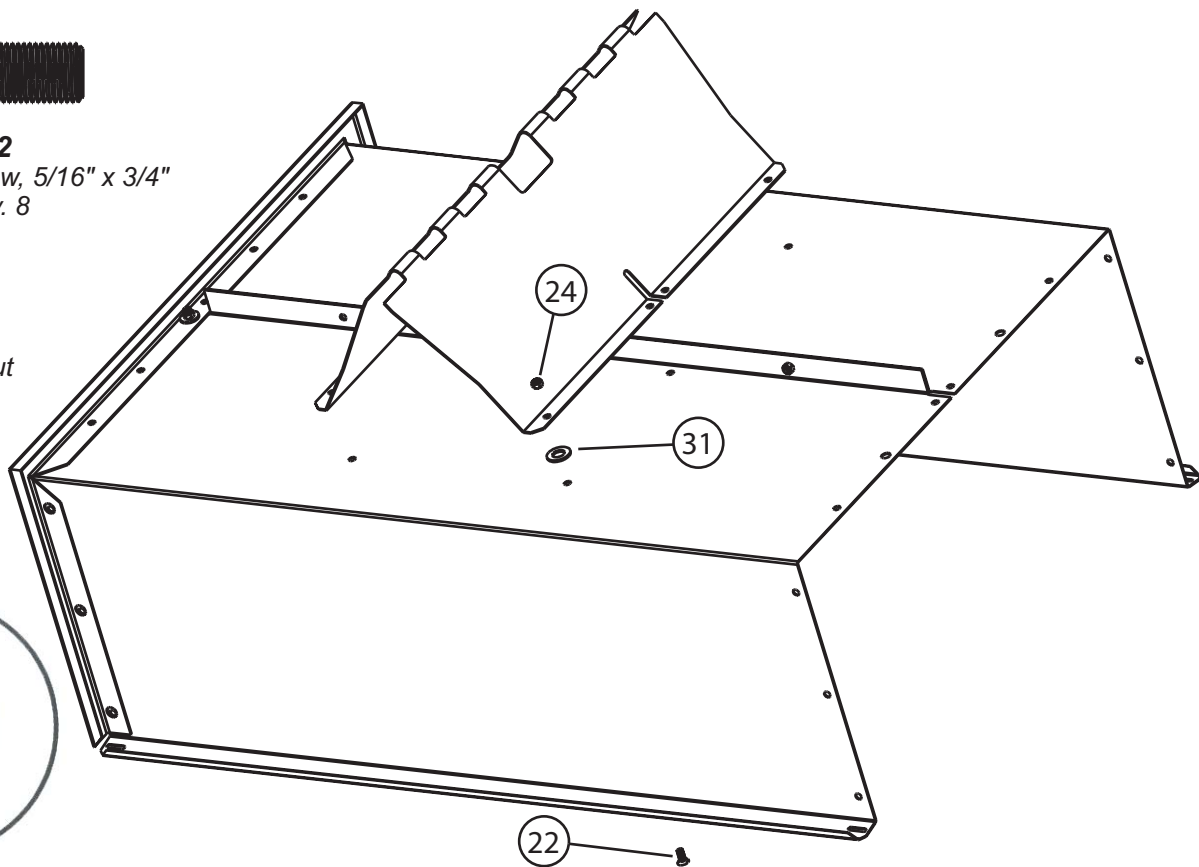
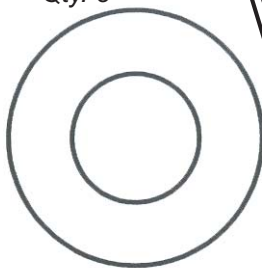

Step 4.

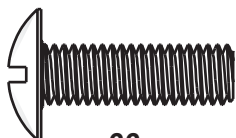

33
Round Head Screw, 5/16" x 1"
Qty. 2

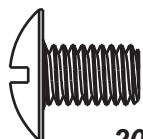

20
Round Head Screw, 5/16" x 1/2"
Qty. 6



24
Hex Lock Nut
Qty. 6

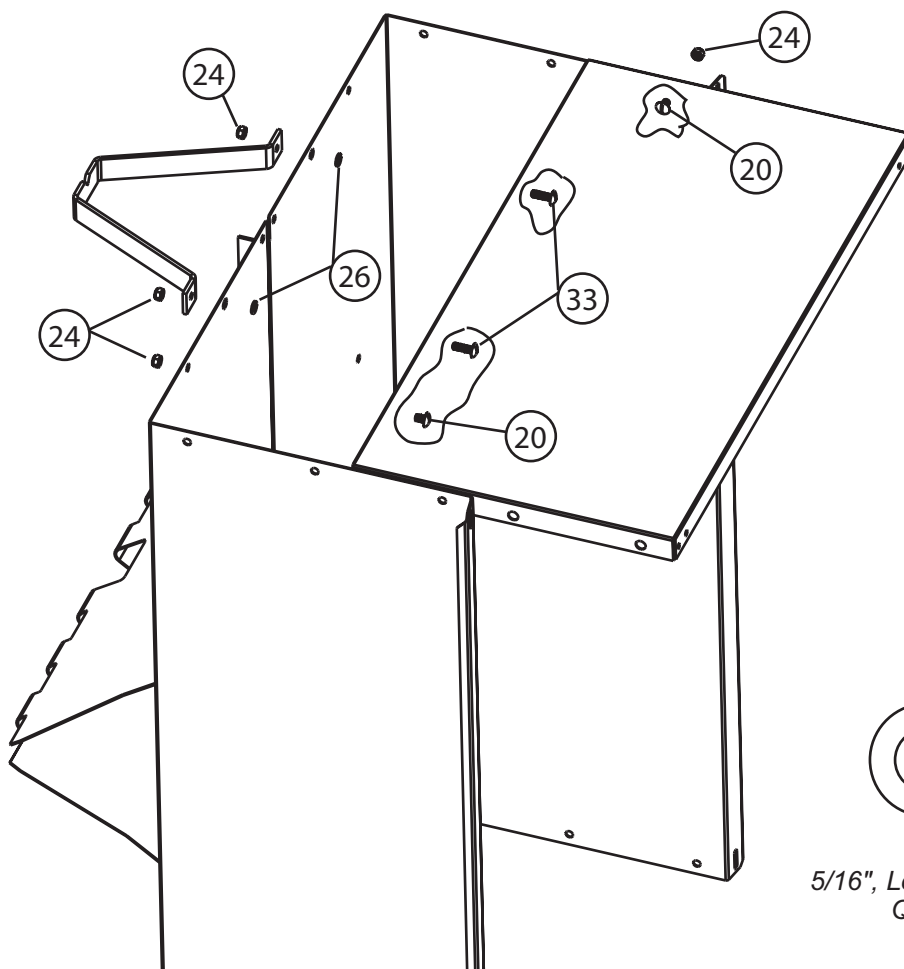

26
5/16", Lock Washer
Qty. 2

Step 5.

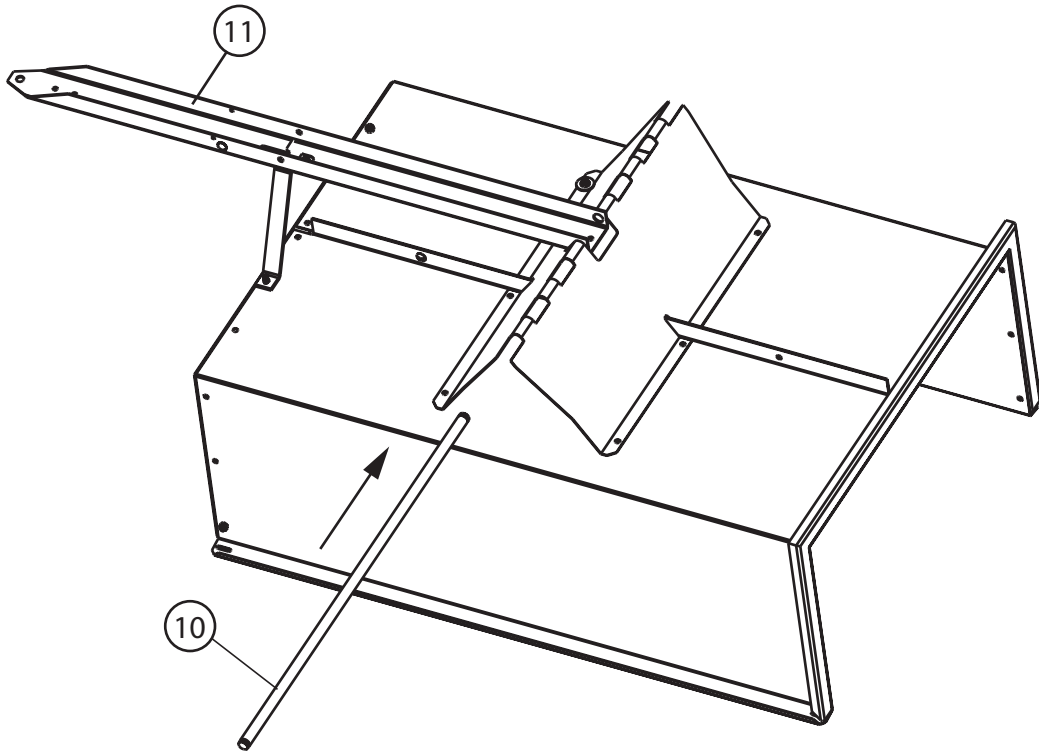

Step 6.

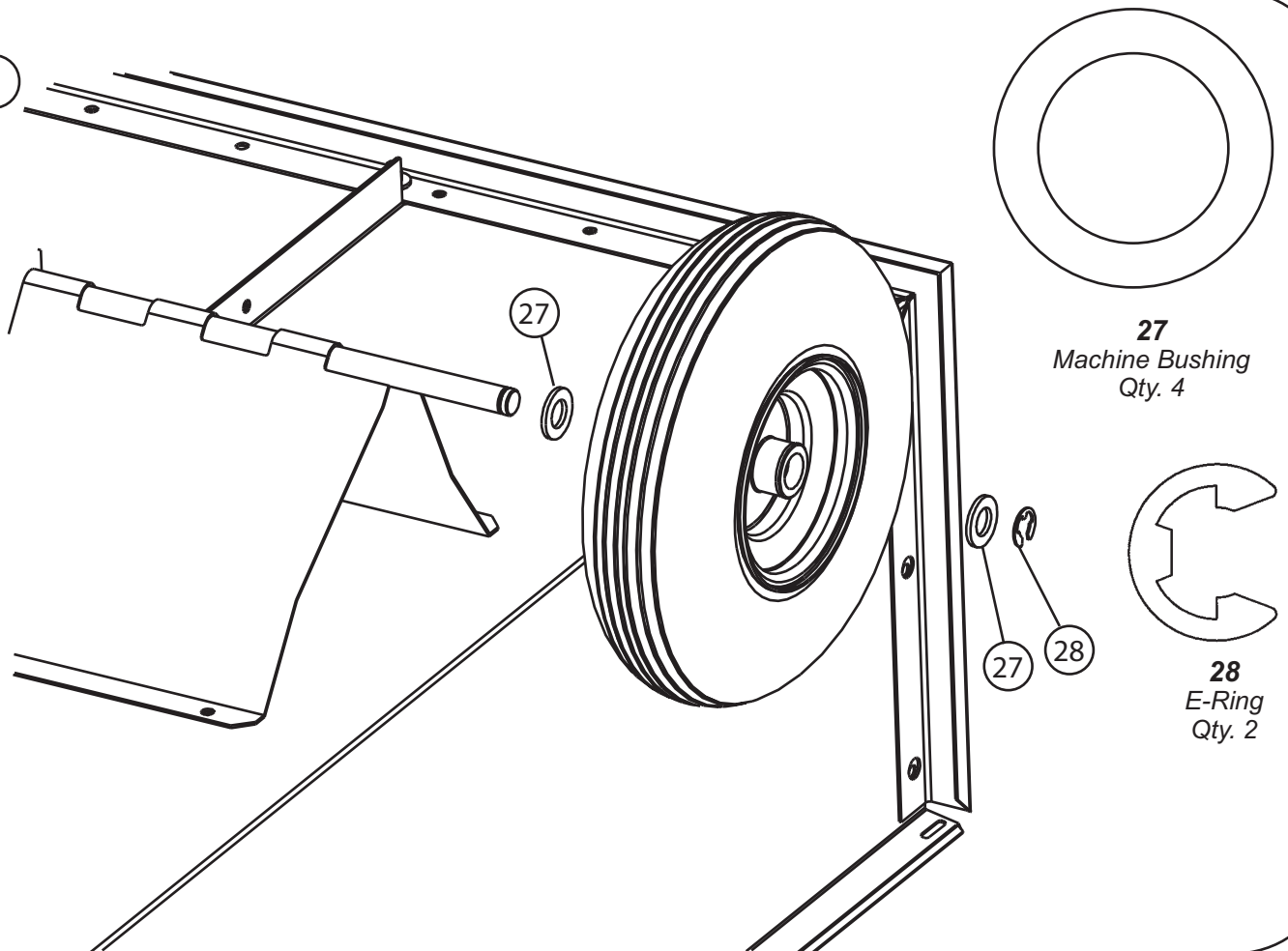

Step 7.

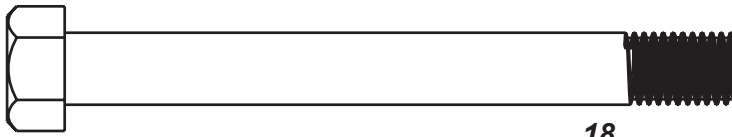

18
Hex Head Bolt, 3/8" x 3-1/2"
Qty. 1

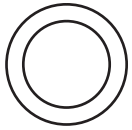

6
Handle Spacer
Qty. 2



1
Hex Lock Nut, 3/8"
Qty. 1

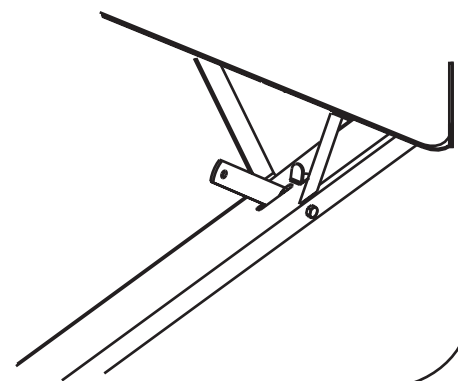
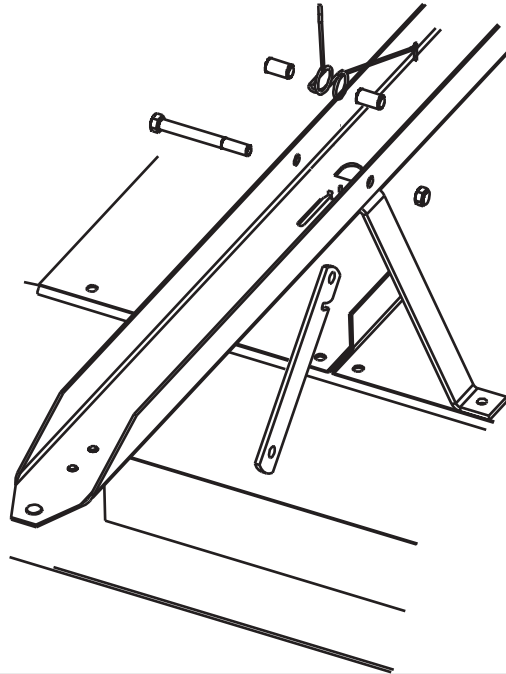
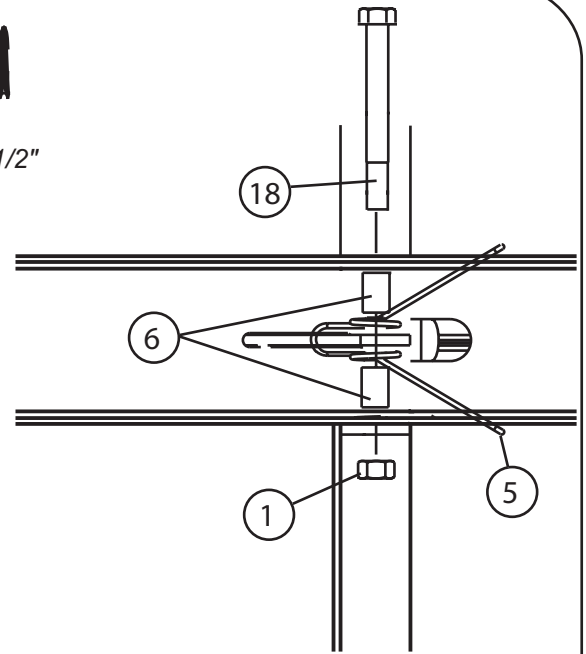

Step 8.

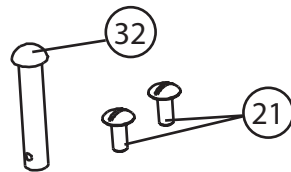

21
Truss Head Screw, 5/16" x 3/4"
Qty. 2

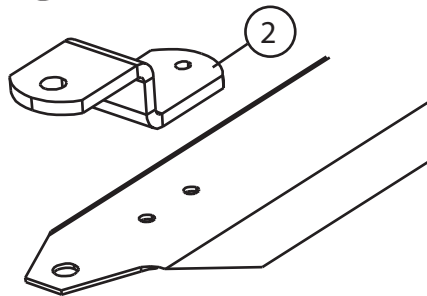

24
Hex Lock Nut
Qty. 2



30
Hairpin Cotter, 1/8"
Qty. 1



32
Drawbar pin, 1/2" x 2-1/4"
Qty. 1

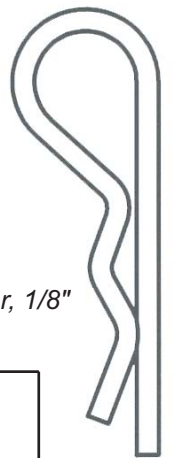

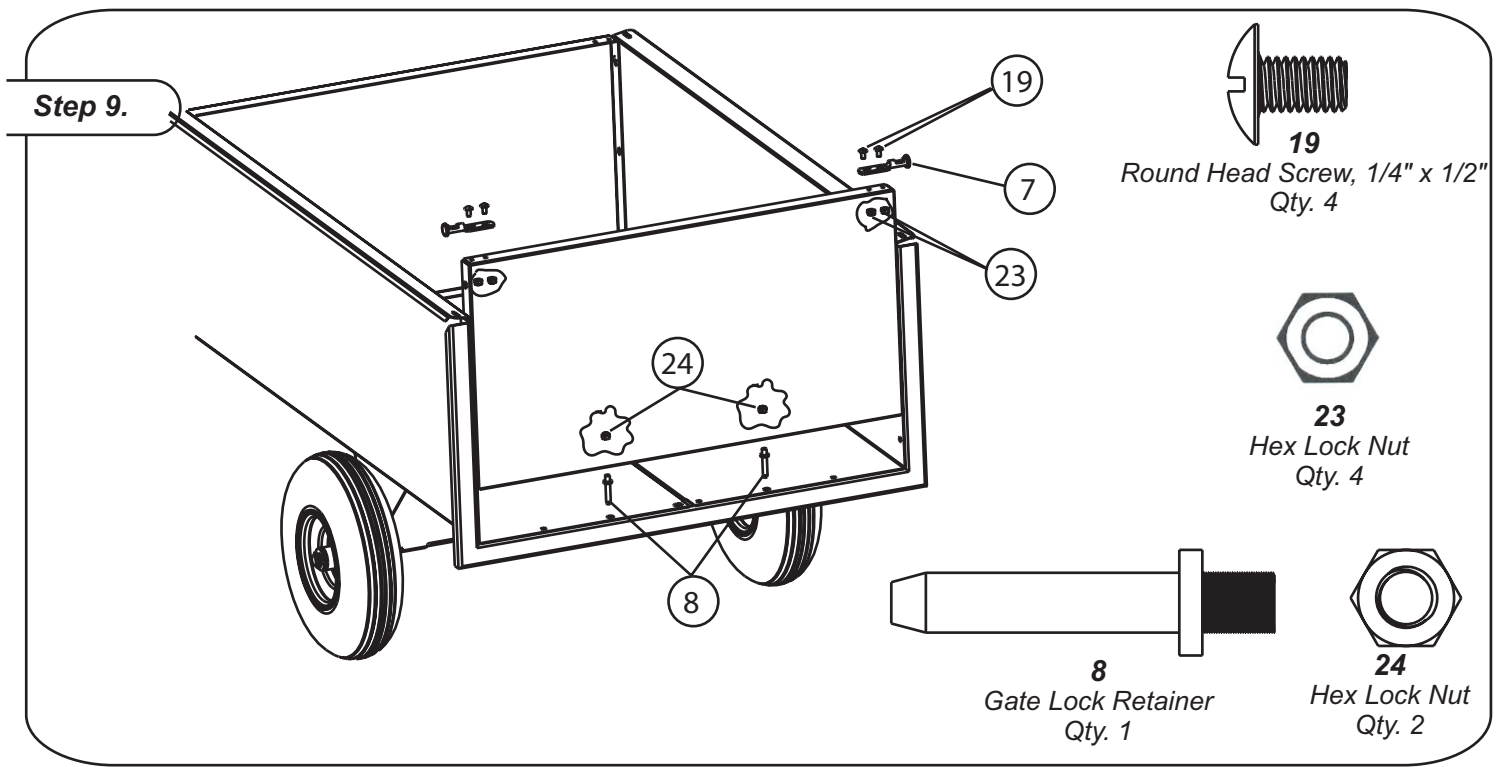

! MAINTENANCE _____

- The key to years of trouble-free service is to keep your Cart clean and dry.
- Unauthorized modifications to the cart may impair its function and safety.
- Occasionally check all moving parts for free movement and, if necessary, lubricate with oil.
- Should rust develop, sand lightly and then paint area with enamel.
- Periodically check all fasteners for tightness.

! OPERATION: _____

- Avoid over filling Cart, it can cause tractor to lose traction and skid. The tractor and operator combined weight **MUST BE** more than loaded cart weight for **PROPER** towing and braking.
- Extremely heavy loads will be difficult to dump. Fill to capacity that is comfortable for you to dump.
- When backing up, carefully back **STRAIGHT** to avoid "jack-knifing", which can cause damage to your equipment.

! IMPORTANT: _____

- Check tire pressure. Inflate to 30 P.S.I.

! SAFETY TIPS: _____

- Avoid tipping and skidding.
- Weight of tractor and operator **MUST BE MORE** than weight of cart and load.
- Use correct number of weights on tractor. If additional weight is required, add this weight at or forward of the rear wheels. Additional weight rearward of rear wheels causes a negative affect on vehicle steering.
- A unsafe load on dry, level ground may cause the tractor to lose traction and skid on slippery or sloped ground.
- DO NOT** use cart near edges of ditch or bank or other steep angle.
- Avoid holes, rocks and roots.
- Slow down before you turn.
- DO NOT** make a sharp turns that cause tractor tires to rub cart drawbar.
- DO NOT** tow cart with box raised.

! KEEP RIDERS OFF CART _____

- Keep riders out of cart.
- Riders in cart are subject to injury, such as being struck by objects and being thrown off the cart during sudden starts, stops and turns.
- Riders obstruct the operator's view, resulting in the cart being used in an unsafe manner.

Limited Warranty

Brinly-Hardy Company warrants only to the original retail purchaser that this product will remain free of defects in workmanship and materials under normal use and service for a period of two (2) years (NOTE: ninety (90) days for commercial or rental use) commencing with the date of purchase.

Any parts found to be defective within the warranty period will be replaced, with proof of date of purchase, at Brinly-Hardy Company's expense. Our obligation under this warranty is expressly limited to replacement or repair, at our option of parts, which are defective in material or workmanship within thirty (30) days of receipt of the parts. This warranty does not apply to damage caused by unreasonable use, including failure to provide necessary maintenance, nor does it apply to any transportation or labor charges.

WE MAKE NO OTHER EXPRESS WARRANTY NOR IS ANYONE AUTHORIZED TO MAKE ANY ON OUR BEHALF. ANY IMPLIED OR STATUTORY WARRANTIES, INCLUDING ANY WARRANTY OF MERCHANTABILITY OR FITNESS FOR A PARTICULAR PURPOSE, ARE LIMITED TO THE DURATION OF THIS WRITTEN WARRANTY. WE SHALL NOT BE LIABLE FOR CONSEQUENTIAL OR INCIDENTAL DAMAGES OF ANY KIND.

MADE IN THE U.S.A.
BRINLY-HARDY COMPANY TOLL-FREE 1-877-728-8224

Free Manuals Download Website

<http://myh66.com>

<http://usermanuals.us>

<http://www.somanuals.com>

<http://www.4manuals.cc>

<http://www.manual-lib.com>

<http://www.404manual.com>

<http://www.luxmanual.com>

<http://aubethermostatmanual.com>

Golf course search by state

<http://golfingnear.com>

Email search by domain

<http://emailbydomain.com>

Auto manuals search

<http://auto.somanuals.com>

TV manuals search

<http://tv.somanuals.com>