

**Canon**  
**FAX-L800**

**User's Guide**

## Trademarks

Canon is a registered trademark and RAPID Fusing System is a trademark of Canon, Inc.

## Copyright

Copyright © 1997 by Canon, Inc. All rights reserved. No part of this publication may be reproduced, transmitted, transcribed, stored in a retrieval system, or translated into any language or computer language in any form or by any means, electronic, mechanical, magnetic, optical, chemical, manual, or otherwise, without the prior written permission of Canon, Inc.



As an ENERGY STAR Partner, Canon has determined that the Canon FAX-L800 meets the Energy Star guidelines for energy efficiency.

Although this equipment can use either loop disconnect or DTMF signalling, only the performance of the DTMF signalling is subject to regulatory requirements for correct operation. It is therefore strongly recommended that the equipment is set to use DTMF signalling for access to public or private emergency services. DTMF signalling also provides faster call set up.



This CE Marking shows compliance of this equipment with Directive 73/23/EEC and Directive 89/336/EEC (as amended by Directive 92/31/EEC), both as amended by Directive 93/68/EEC.

L'estampille CE indique que ce matériel est conforme aux dispositions de la Directive 73/23/CEE et de la Directive 89/336/CEE (modifiée par la Directive 92/31/CEE), toutes deux modifiées par la Directive 93/68/CEE.

Diese CE-Markierung weist darauf hin, daß dieses Gerät mit Richtlinie 73/23/EWG und der durch Richtlinie 92/31/EWG geänderten Richtlinie 89/336/EWG übereinstimmt, die beide durch Richtlinie 93/68/EWG geändert wurden.

Denne CE-mærkning indikerer, at dette udstyr følger Direktiv 73/23/EU og Direktiv 89/336/EU (som udvidet med Direktiv 92/31/EU), begge som udvidet med Direktiv 93/68/EU.

CE Märkningen visar att denna utrustning följer direktiven 73/23/EEC och 89/336/EEC (komplement till 92/31/EEC) båda som komplement till direktiv 93/68/EEC.

CE merkintä osoittaa tämmän tuotteen yhteensopivuuden direktiivien 73/23/EEC ja 89/336/EEC (täydennetty direktiivillä 92/31/EEC) kanssa, joita on täydennetty direktiivillä 93/68/EEC.

Dette CE merket viser at utstyret er i samsvar med EU direktivene 73/23 og 89/336 (med korreksjon av EU direktiv 92/31), begge med korreksjon av EU direktiv 93/68.

Deze CE marking toont aan dat het product in overeenstemming is met de richtlijnen 73/23/EEC en 89/336/EEC (zoals geamendeerd door richtlijn 92/31/EEC), welke beide zijn geamendeerd door de richtlijn 93/68/CEE.

Questo contrassegno CE indica che l'apparecchio è conforme alle Direttive CEE 73/23 e 89/336 (successivamente modificata con la Direttiva 92/31), entrambe modificate con la Direttiva 93/68.

Este símbolo CE indica que el equipo cumple con las Directivas 73/23/EEC y 89/336/EEC (según la enmienda a la Directiva 92/31/EEC), ambas según la enmienda de la Directiva 93/68/EEC.

Esta marca CEE indica que este equipamento está de acordo com as Directivas 73/23/EEC e 89/336/EEC (conforme emenda da directiva 92/31/EEC), ambas emendas da directiva 93/68/EEC.

Αυτή η CE σήμανση δηλώνει την συμφωνία της Συσκευής με την Οδηγία 73/23/EEC και την Οδηγία 89/336/EEC (όπως τροποποιήθηκαν από την Οδηγία 92/31/EEC), όπως αμφότερες έχουν τροποποιηθεί από την Οδηγία 93/68/EEC.

Oznaka CE prikazuje, da oprema ustreza predpisu 73/23/EEC, in kot to predpisuje predpis 93/68/EEC.

A CE jelzés tanúsítja, hogy a berendezés megfelel az EEC 92/31 és 93/68 előírásokkal módosított EEC 73/23 és 89/336 követelményrendszernek.

Oznaczenie CE jest potwierdzeniem zgodności niniejszego urządzenia z wymaganiami Dyrektywy 73/23/EEC oraz Dyrektywy 89/336/EEC (zgodnie ze zmianami Dyrektywy 92/31/EEC), obie uzupełnione przez Dyrektywę 93/68/EEC.

Značka CE indikuje, že toto zařizení odpovídá Směrnicí 73/23/EEC a Směrnicí 89/336/EEC (doplňené Směrnicí 92/31/EEC), které byly dále doplněny Směrnicí 93/68/EEC.

Käesolev CE-markeerung näitab, et antud seade vastab Euroopa Liidu Direktiividele 73/23/EEC ja 89/336/EEC (koos muudatustega vastavalt Direktiivile 92/31/EEC) ning võttes arvesse, et mõlemaid direktiive on muudetud vastavalt Direktiivile 93/68/EEC.

CE marķējums norāda, ka šī iekārta atbilst prasībām, kas iekļautas EK direktīvās 73/23 un 89/336 (ar EK direktīvā 92/31 paredzētajām izmaiņām), kurās veikti labojumi saskaņā ar EK direktīvu 93/68.

Ženklas CE reiškia, kad šis įrenginys atitinka direktyvas 73/23/EEC ir 89/336/EEC (atlikus pataisus direktyva 92/31/EEC), kuriose buvo atliktos pataisus direktyva 93/68/EEC.

Маркировка CE указывает на то, что данное оборудование соответствует Директиве 73/23/EEC и Директиве 89/336/EEC (с изменениями в соответствии с Директивой 92/31/EEC) с изменениями, предписываемыми Директивой 93/68/EEC.

Fax III

# Laser Safety

Laser radiation could be hazardous to the human body. For this reason, laser radiation emitted inside this fax is hermetically sealed within the protective housing and external cover. In the normal operation of the product by the user, no radiation can leak from the machine.



Use of controls, adjustments, or performance of procedures other than those specified in this User's Guide may result in hazardous radiation exposure.

This label is attached to the laser scanner unit inside the fax and is not in a user access area.

	<b>DANGER</b> - Invisible laser radiation when open. AVOID DIRECT EXPOSURE TO BEAM.
	<b>CAUTION</b> - INVISIBLE LASER RADIATION WHEN OPEN. AVOID EXPOSURE TO BEAM.
	<b>ATTENTION</b> - RAYONNEMENT LASER INVISIBLE EN CAS D'OUVERTURE. EXPOSITION DANGEREUSE AU FAISCEAU.
	<b>VORSICHT</b> - UNSICHTBARE LASERSTRAHLUNG, WENN ABDECKUNG GEÖFFNET. NICHT DEM STRAHL AUSSETZEN.
	<b>ATTENZIONE</b> - RADIAZIONE LASER INVISIBLE IN CASO DI APERTURA. EVITARE L'ESPOSIZIONE AL FASCIO.
	<b>PRECAUCION</b> - RADIACION LASER INVISIBLE CUANDO SE ABRE. EVITAR EXPONERSE AL RAYO.
	<b>VARO!</b> - ÄÄVÄTTÄESSÄ OLET ALTTIINA NÄKYMÄTTÖMÄLLE LASERSÄTEILYLLE. ÄLÄ KATSO SÄTEESEEN.
	<b>WARNING!</b> - OSYNLIG LASERSTRÅLNING NÄR DENNA DEL ÄR ÖPPNAD. BETRÄKTA EJ STRÅLEN.
	<b>ADVARSEL!</b> - USYNLIG LASER STRÅLING, NÄR DENNE ER ÅBEN. UNNGÅ BESTRÅLING.
	<b>ADVARSEL</b> - USYNLIG LASERSTRÅLING, NÄR DEKSEL ÅPNES. UNNGÅ EKSPONERING FOR STRÅLEN.
	<b>注意</b> - このカバーの内側では不可視レーザー光が照射されています。 レーザー光にさらされないようにしてください。 RS5-8169

The label below is attached on the rear side of the fax.

<p>CLASS1 LASER PRODUCT APPAREIL A RAYONNEMENT LASER DE CLASSE 1 LASER KLASSE 1 APPARECCHIO LASER DI CLASSE 1 PRODUCTO LASER DE CLASE 1 APARELHO A LASER DE CLASSE 1 EN60825:1991</p>
---

# Contents

---

<b>Chapter 1</b>	<b>Welcome!</b> .....	<b>1-1</b>
	Main Features .....	1-2
<b>Chapter 2</b>	<b>Setting Up</b> .....	<b>2-1</b>
	How to Use This Guide .....	2-2
	Where to Set Up the Fax .....	2-3
	Space Around the Fax .....	2-5
	Power Requirements .....	2-6
	General Precautions .....	2-7
	Unpacking: Have You Got Everything? .....	2-9
	Parts of the Fax .....	2-11
	Front View .....	2-11
	Rear View .....	2-12
	Handset (option) .....	2-12
	Removing the Shipping Material .....	2-13
	Removing the Shipping Tape .....	2-13
	Removing the Spacers Inside the Fax Unit .....	2-13
	Removing the Styrofoam Sheet from the ADF .....	2-14
	Removing the Orange Lock Plate from the Front Paper Cassette .....	2-15
	Removing the Protective Sheets .....	2-16
	Assembling the Fax .....	2-17
	Installing the Toner Cartridge .....	2-17
	Attaching Trays .....	2-20
	Connecting the Handset (an option) .....	2-20
	Connecting the Telephone Line .....	2-21
	Connecting an Extension Phone .....	2-22
	Loading Paper and Installing the Paper Cassettes .....	2-22
	Loading Paper in the Side Paper Cassette .....	2-23
	Loading Paper in the Front Paper Cassette .....	2-25
	Turning on the Power .....	2-27
<b>Chapter 3</b>	<b>Getting Started</b> .....	<b>3-1</b>
	Operation Buttons (One-touch panels closed) .....	3-2
	Operation Buttons (One-touch panels open) .....	3-4
	Using the Menus and Buttons .....	3-5
	General Guidelines for Registering Information .....	3-5
	Using the Menu .....	3-5
	To Open a Menu and Select an Item .....	3-6
	To Return to the Previous Level .....	3-6
	To Return to Standby Immediately .....	3-6
	Entering Names for Registration .....	3-7
	To Correct a Mistake .....	3-8
	Menu Button Summary Table .....	3-8

Checking and Setting the Telephone Line .....	3-10
Registering Required Sender Information .....	3-11
What is Sender Information? .....	3-12
Registering the Sender Information .....	3-13
Registering Sender Names .....	3-17
Registering a Sender Name .....	3-17
Changing or Erasing a Sender Name .....	3-18
Using the Energy Saver Mode .....	3-19
Turning the Energy Save Feature ON .....	3-19
Returning to the Full Power Mode .....	3-21
<b>Chapter 4</b>	
<b>Setting Up and Using Speed Dialling .....</b>	<b>4-1</b>
Read This before Entering Telephone Numbers .....	4-2
Entering Pauses for Dialling .....	4-2
Adjusting the Length of a Pause .....	4-3
Confirming a dial tone .....	4-4
What is Speed Dialling? .....	4-5
One-touch Speed Dialling .....	4-5
Coded Speed Dialling .....	4-5
Group Dialling .....	4-5
Setting Up One-touch Speed Dialling .....	4-6
Setting Up Coded Speed Dialling .....	4-14
Setting Up Group Dialling .....	4-22
Using Speed Dialling .....	4-26
Using One-touch Speed Dialling .....	4-26
Using Coded Speed Dialling .....	4-28
Using Group Dialling .....	4-29
Using Directory Dialling .....	4-31
<b>Chapter 5</b>	
<b>Using the Fax as a Copier .....</b>	<b>5-1</b>
Preparing the Document .....	5-2
Setting the Document on the Fax .....	5-3
Performing the Document Settings .....	5-4
Making Copies .....	5-5
<b>Chapter 6</b>	
<b>Sending Documents .....</b>	<b>6-1</b>
Setting a Document for Sending .....	6-2
Preparing the Document .....	6-2
Setting the Document on the Fax .....	6-3
Adjusting the Scanning Settings .....	6-4
Selecting a Sender Name .....	6-6
Using Regular Dialling .....	6-7
Cancelling Sending a Document .....	6-8
Dialling Long Distance with Regular Dialling .....	6-9
Overview of Sending Methods .....	6-11
Memory Sending .....	6-11
Direct Sending .....	6-13
Manual Sending .....	6-15

	Re-dialling When the Line is Busy .....	6-16
	What is Automatic Redialling? .....	6-16
	Setting Up Redialling .....	6-18
	Auto Redial Setup Summary .....	6-19
	Sequential Broadcasting to More Than One Location .....	6-20
	Sending Documents at a Preset Time .....	6-21
	Sending a Document with a Subaddress/Password .....	6-24
	Subaddress/Password Sending with Speed Dialling .....	6-24
	Subaddress/Password Sending with the Operation Panel Buttons .....	6-25
<b>Chapter 7</b>	<b>Receiving Documents .....</b>	<b>7-1</b>
	Receiving Documents Automatically .....	7-2
	Setting the Automatic Receive Mode .....	7-2
	Messages Displayed When Receiving a Document .....	7-2
	Turning on and Adjusting the Auto Switch Time .....	7-4
	Receiving Documents Manually with the Optional Handset .....	7-6
	Receiving a Document Manually at the Fax .....	7-6
	Receiving a Document Manually with an Extension Telephone .....	7-7
	Changing the Remote Receive ID .....	7-8
	Cancelling Receiving a Document .....	7-10
	Transferring Documents .....	7-11
	Before You Set Up Document Transfer .....	7-11
	Setting Up the Fax for Document Transfer .....	7-12
	Turning the Transfer Mode ON and OFF .....	7-15
	Turning Transfer Mode ON .....	7-15
	Turning Transfer Mode OFF .....	7-15
	Changing the Transfer Settings .....	7-16
	Cancelling the Transfer Settings .....	7-17
<b>Chapter 8</b>	<b>Using the Memory Features .....</b>	<b>8-1</b>
	When the Fax Displays RECEIVED IN MEMORY .....	8-2
	Displaying the Transaction History .....	8-3
	Printing a Memory List .....	8-4
	Printing a Document in the Memory .....	8-5
	Re-sending a Document to the Same Destination .....	8-6
	Sending a Document in Memory to a Different Destination .....	8-7
	Erasing a Document from the Memory .....	8-8
	Deleting a Document with the DELETE FILE Button .....	8-9
	Deleting a Document with the MEMORY REFERENCE Button .....	8-9

Setting Up and Using a Memory Box .....	8-10
Before You Create Memory Boxes .....	8-11
When You Create a Memory Box .....	8-11
Access Settings .....	8-12
Main Settings .....	8-12
Feature Settings .....	8-13
Creating a Memory Box .....	8-13
Changing the Memory Box Settings .....	8-19
Cancelling a Memory Box .....	8-21
Sending a Document Stored in the Memory Box .....	8-22
Printing a Document Received in a Memory Box .....	8-23
What Happens to Memory after a Power Failure .....	8-24
How Your Registered Data Is Protected .....	8-24
About the Backup Battery .....	8-25
<b>Chapter 9</b>	
<b>Using a Relay Network .....</b>	<b>9-1</b>
What is Relay Broadcasting? .....	9-2
Setting Up and Using a Standard Relay Unit .....	9-2
Setting Your Fax as a Relay Unit .....	9-3
Changing the Relay Broadcast Settings .....	9-6
Deleting the Relay Group .....	9-7
Sending a Document to a Relay Unit for Relay Broadcasting .....	9-8
Sending a Document to a Relay Unit with Speed Dialling .....	9-9
Sending with the RELAY BROADCAST Button .....	9-10
<b>Chapter 10</b>	
<b>Using Confidential Mailboxes .....</b>	<b>10-1</b>
Setting Up and Using the Standard Mailbox Features .....	10-2
Creating a Mailbox .....	10-2
Changing Mailbox Settings .....	10-5
Cancelling a Mailbox .....	10-6
Receiving a Confidential Document .....	10-7
Sending a Confidential Document .....	10-9
Sending a Confidential Document with Speed Dialling .....	10-9
Sending a Confidential Document with the Confidential Mailbox Button .....	10-10

<b>Chapter 11</b>	<b>Setting Up and Using Polling</b> .....	<b>11-1</b>
	What's Polling? .....	11-2
	Before You Use Polling Receiving .....	11-2
	Polling Other Fax Machines to Receive a Document .....	11-3
	Polling to Receive at a Preset Time .....	11-5
	Changing the Preset Polling Settings .....	11-11
	Cancelling Preset Polling .....	11-12
	Setting Up Polling Sending .....	11-13
	Before You Can Be Polled to Send .....	11-13
	Setting Up a Polling Box .....	11-13
	Scanning a Document into the Memory for Polling Sending .....	11-17
	Changing the Polling Box Setup .....	11-19
	Cancelling a Polling Box .....	11-20
<b>Chapter 12</b>	<b>Other Special Features</b> .....	<b>12-1</b>
	Using the Telephone .....	12-2
	Tone Dialling on a Pulse Line .....	12-3
	Setting and Using the Program Button .....	12-4
	Setting Up and Using the Optional Stamp Feature .....	12-7
	Setting Up the Stamp Feature .....	12-7
	Turning the Stamp Feature ON/OFF .....	12-9
	How the Fax Operates with Default Settings .....	12-10
<b>Chapter 13</b>	<b>Restricting Use of the Fax</b> .....	<b>13-1</b>
	Setting and Using the System Settings Password .....	13-2
	Setting the System Settings Password .....	13-2
	Changing or Cancelling the System Settings Password .....	13-3
	Restricting Fax Operation .....	13-5
	Setting Operation Restrictions .....	13-5
	Operating the Fax with Restrictions ON .....	13-9
	Sending a Document with Restrictions ON .....	13-9
	Making a Copy with Restrictions ON .....	13-11
	Printing a Report with Restrictions ON .....	13-11
	Using the Telephone with Restrictions ON .....	13-12
	Turning Restrictions OFF and ON .....	13-12
	Receiving Documents from Registered Senders Only .....	13-14
	Using Memory Lock .....	13-15
	Setting a Time and Password for Memory Lock .....	13-15
	Turning Memory Lock ON .....	13-18
	Turning Memory Lock OFF and Printing Documents .....	13-18



<b>Chapter 14</b>	<b>Printing Reports and Lists</b> .....	<b>14-1</b>
	Printing the Speed Dialling Lists .....	14-2
	Printing the User Data List .....	14-5
	Printing the List of Sender Names .....	14-6
	Activity Reports .....	14-7
	Printing the Activity Management Report .....	14-7
	Setting and Using Activity Reports .....	14-9
	Memory Lists .....	14-15
<b>Chapter 15</b>	<b>Maintenance &amp; Frequently Asked Questions</b> .....	<b>15-1</b>
	Removing Document Feed Jams .....	15-2
	Removing Printer Feed Jams .....	15-3
	Storing Recording Paper .....	15-13
	Recommended Paper .....	15-13
	Storing the Paper Supply .....	15-13
	Changing the Toner Cartridge .....	15-14
	Storing Toner Cartridges .....	15-17
	Handling Cartridges .....	15-17
	Storing Cartridges .....	15-18
	Periodic Cleaning .....	15-18
	Cleaning the Fax Unit .....	15-18
	Opening and Closing the Operation Panel .....	15-19
	Opening the Operation Panel .....	15-19
	Closing the Operation Panel .....	15-21
	Cleaning the Scanning Area .....	15-22
	Refilling the Stamp Ink Compartment (Option) .....	15-23
	Error Code Table (listed by number) .....	15-24
	List of LCD Display Messages (Alphabetic List) .....	15-26
	Questions and Answers .....	15-30
	Can not Send Documents Correctly? .....	15-30
	Can not Receive Documents Correctly? .....	15-32
	Can not Copy Documents? .....	15-34
	Having Other Problems? .....	15-34
	Recording the User Reminder Sheets .....	15-35
<b>Chapter 16</b>	<b>Summary of Important Settings</b> .....	<b>16-1</b>
	Opening the Data Registration Menu .....	16-2
	Summary of User Data Settings .....	16-3
	User Settings .....	16-4
	Report Settings .....	16-7
	TX (Send) Settings .....	16-9
	RX (Receive) Settings .....	16-12
	Printer Settings .....	16-14
	File Settings .....	16-17
	System Settings .....	16-23
	Relationship between BATCH TX, QUICK ON-LINE TX, and Timer Settings .....	16-27

<b>Appendix A</b>	<b>Specifications</b> .....	<b>A-1</b>
	General .....	A-1
	Operation .....	A-2
	Dial Features .....	A-3
	Networking Features .....	A-3
	Copier Features .....	A-3
	Telephone Features .....	A-4
	Power .....	A-4
	Operating Environment .....	A-4
	Weight .....	A-4
	Dimensions .....	A-5
<b>Appendix B</b>	<b>Documents You Can Scan</b> .....	<b>B-1</b>
	Document Media to Avoid .....	B-1
	Specifications for Paper Documents You Can Scan .....	B-1
	Document Thickness .....	B-1
	Document Size .....	B-2
	Scanning Area on the Document .....	B-2
	Printing Area .....	B-3
<b>Glossary</b>	.....	<b>G-1</b>
<b>Index</b>	.....	<b>I-1</b>

# Chapter 1

## Welcome!

---

Thank you for purchasing the new Canon FAX-L800. This new facsimile unit with its added features and greater flexibility enabled by full support of ITU-T subaddress/password sending and receiving will help you expand your work capacity and efficiency.

This User's Guide shows you how to get the most out of your new facsimile unit. Whether you are sending a quick memo to the home office on the other side of town or automatically receiving from a branch overseas or across the country, this book shows you how to do it all quickly and easily.

Take a few minutes to browse through this User's Guide so you know what it contains. You do not have to read it all at once from cover to cover.

We have done our best to give you an accurate, easy-to-use User's Guide, but if you still have some questions about how to use your facsimile unit, feel free to contact your local authorized Canon dealer sales or service representatives. They will be glad to answer your questions.

# Main Features

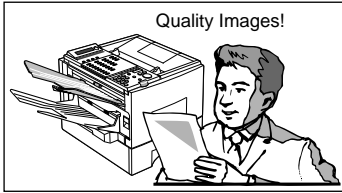

## Ultra High Quality (UHQ) image

Canon's ultra-high quality image processing produces excellent reproductions in documents you send and copy.

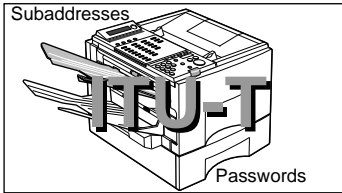

## Full support of ITU-T subaddresses and passwords

You can employ ITU-T subaddresses and passwords to communicate not only with other Canon faxes, but fax machines of other manufacturers as well.

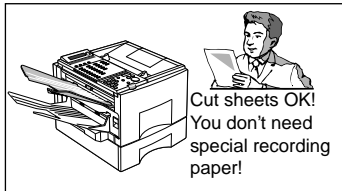

## Laser beam printer

Quiet, clean laser technology guarantees quality reproduction.

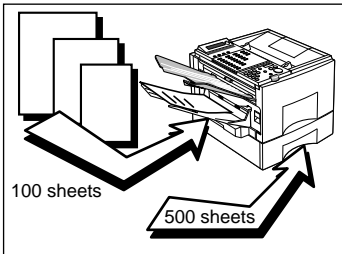

## Large paper supply

A large paper supply means less time spent loading paper in the paper cassettes. The side paper cassette can be adjusted to fit a variety of standard paper sizes and hold a stack of up to 100 sheets. The standard front paper cassette holds 500 sheets, for a total of 600 sheets. The additional lower cassette, available as an option holds another 500 sheets for a total of 1100 sheets. All cassettes are easy to access and re-fill.

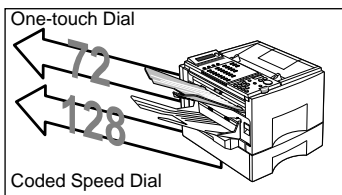

## Automatic dialling

Includes One-touch and Coded Speed Dialling, Directory Dialling, as well as Group dialling which allows you to send the same document to several destinations at the touch of a button.

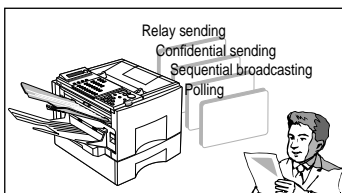

## Variety of send and receive features

Includes multiple broadcasting, polling, relay sending and receiving, and confidential mailbox sending and receiving.

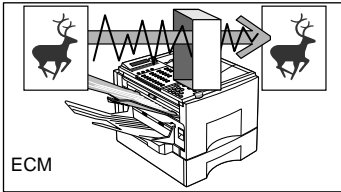

### ECM send and receive

ECM (error correction mode) reduces errors during sending and receiving on noisy or poor quality telephone lines.

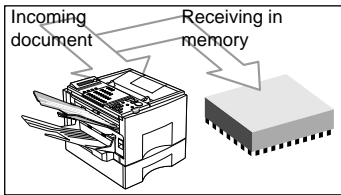

### Memory receiving when you run out of paper

If you run out of paper while you are receiving a document, the fax unit continues to receive by putting the remainder of the document in the fax memory so you can print it out after you refill the paper cassette. A memory backup function also safeguards the contents of the memory for approximately 12 hours after a power failure.

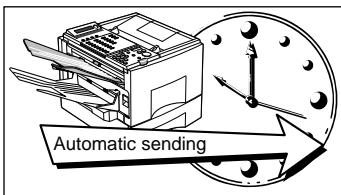

### Delayed sending

Scan a document into the memory and set for sending at a later time so you can take advantage of holiday or late night telephone rates.

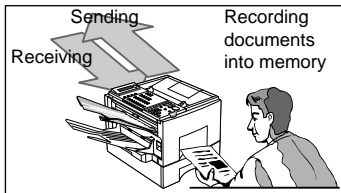

### Dual access

Even while you are sending or receiving a document, you can continue to use the fax to register information with the fax or record documents into the memory.

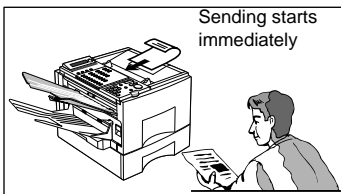

### Quick-on-line TX

Before the fax is finished scanning a long document, it will start dialling and sending the pages that are already scanned. By the time the last page is scanned, the document transmission is well under way.

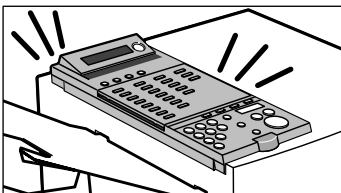

### Easy to use

A larger display and control panel with larger buttons makes the fax easier to use.

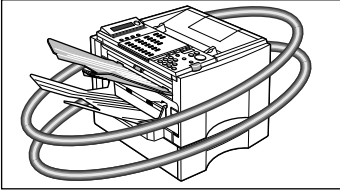

### **Economical and quiet**

Canon's RAPID Fusing System™ realizes quiet operation while you save money. If the fax machine remains idle for a specified length of time, the fax machine automatically shuts itself down and enters the low energy sleep mode, and will remain in this low energy mode until the fax machine receives a document transmission or until you press the ENERGY SAVER button.

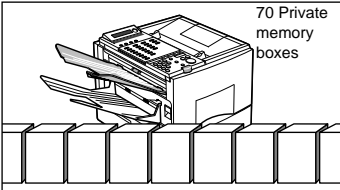

### **Expanded transaction features**

You can create up to 70 private memory boxes and set them up to receive documents. If the other party's fax can use ITU-T subaddresses and passwords, you can set up and use memory boxes even if the other party's fax unit is not a Canon fax.

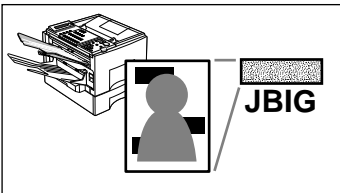

### **JBIG, Improved image data compression**

JBIG is a new ITU-T standard image data compression method. JBIG's compression method allows data to be compressed more efficiently\* than MMR, a conventional compression method. JBIG is especially effective when transmitting halftone image documents. Because the smaller data size requires less transmission time, JBIG saves you time and money.

\* Actual compression ratio may vary with image.

# Chapter 2

## Setting Up

---

This chapter shows you how to set up the fax unit.

Even if your fax unit has been set up for you, take a few minutes to glance through this chapter to become familiar with how to use this user's guide. You may also want to check the fax installation to confirm that it has been done correctly.

How to Use This Guide .....	2-2
Where to Set Up the Fax .....	2-3
Space Around the Fax .....	2-5
Power Requirements .....	2-6
General Precautions .....	2-7
Unpacking: Have You Got Everything? .....	2-9
Parts of the Fax .....	2-11
Front View .....	2-11
Rear View .....	2-12
Handset (option) .....	2-12
Removing the Shipping Material .....	2-13
Removing the Shipping Tape .....	2-13
Removing the Spacers Inside the Fax Unit .....	2-13
Removing the Styrofoam Sheet from the ADF .....	2-14
Removing the Orange Lock Plate from the Front Paper Cassette .....	2-15
Removing the Protective Sheets .....	2-16
Assembling the Fax .....	2-17
Installing the Toner Cartridge .....	2-17
Attaching Trays .....	2-20
Connecting the Handset (an option) .....	2-20
Connecting the Telephone Line .....	2-21
Connecting an Extension Phone .....	2-22
Loading Paper and Installing the Paper Cassettes .....	2-22
Turning on the Power .....	2-27

# How to Use This Guide

Before you use this guide, read this list of symbols, terms, and abbreviations, and make sure you know what they mean. A complete glossary of terms is included at the end of this User's Guide.

- (→2-12) A number preceded by an arrow and enclosed in parentheses references a page number in this User's Guide which contains more information about the topic of the previous sentence.
- default A setting that remains in effect unless you change it.
- document A document is the original sheet(s) of paper you send, receive, or copy on the facsimile.
- menu A menu is a list of options or features from which you select an item to set up or change. A menu has a number and title which appear in the two-line display.
- search buttons The search buttons (^ v) change the LCD display. Press v to display the next item or choice in a menu, or press ^ to display the previous item or choice.
- transaction number When you send or receive a document, your fax automatically assigns the document a unique transaction number. A transaction number is a four-digit decimal number that will help you keep track of documents you send and receive.
- TX/RX NO. On the LCD display, **TX/RX NO.** is the abbreviation used for *transaction number*
- RX Denotes *receiving*.
- TX Denotes *transmitting* or *sending*.



---

A note describes helpful hints, restrictions, or how to avoid minor difficulties.

---



---

Cautions show you how to avoid conditions or incorrect operations that could cause damage to your hardware or software or cause personal injury.

---

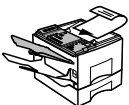

This icon denotes feeding a document.



# Where to Set Up the Fax

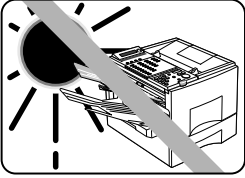

- Avoid direct sunlight. If you have to locate the fax near a window, install heavy curtains or blinds to protect the fax from direct sunlight.

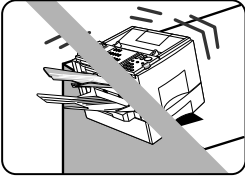

- Choose a flat, stable surface free of vibration.

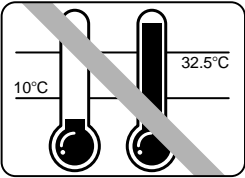

- Avoid a location subject to extreme temperature fluctuation. Use in a location within a temperature range of 10°C to 32.5°C.

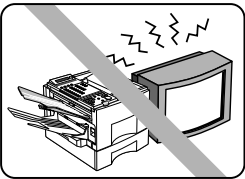

- Do not set up the fax near a television, radio, or heavy equipment like copy machines, air conditioners, computers, or large printers that can generate strong electromagnetic fields. Large equipment can generate electronic noise that can interfere with the operation of the fax.

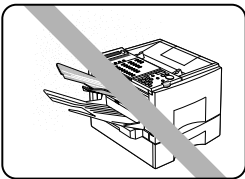

- Choose a location that is clean and free from dust and moisture.

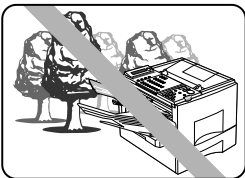

- Do not use or store the fax outdoors.

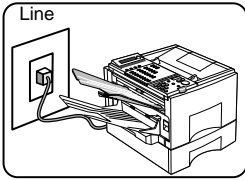

- Place the fax unit near a telephone line.

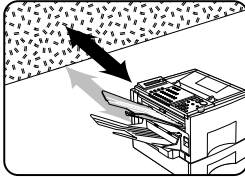

- To avoid damage to the fax unit from overheating, do not block the exhaust vent. Install the fax unit approximately 10 cm away from walls or other equipment.

# Space Around the Fax

To ensure proper ventilation and easy operation, set up the fax in an area that meets the minimum requirements for clearance as illustrated below.



To avoid damage to the fax unit from overheating, do not block the exhaust vent. Install the fax unit approximately 10 cm away from walls or other equipment.

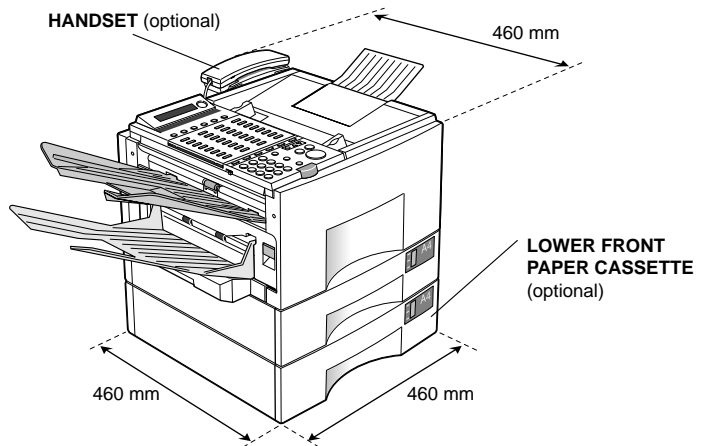
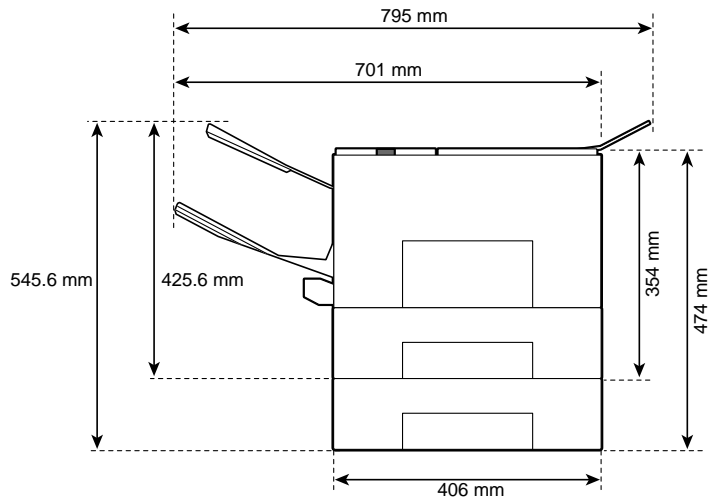

# Power Requirements

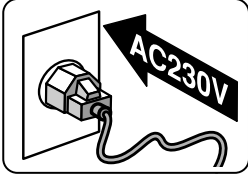

- Place the fax near a standard 230 V AC power outlet. This fax unit is intended for domestic use. Do not attempt to use it outside the country where you purchased it.

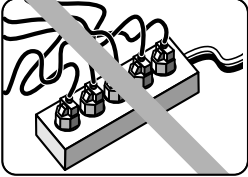

- Do not plug the power cord into an extension cord connector or power strip shared with other plugs.

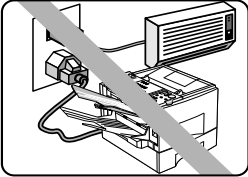

- Do not plug the fax into a power outlet shared with an air conditioner, personal computer, electric typewriter, copier, or other equipment that generates electrical noise.

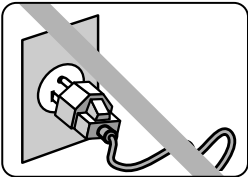

- Check the plug frequently and make sure that it is firmly plugged into the socket.
- Do not plug the power cord into an uninterruptable power supply (UPS).

# General Precautions

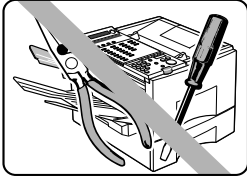

- To avoid serious injury, never disassemble the fax. Exposed power points inside the fax can cause electrical shock if you touch them.

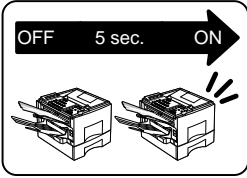

- After you unplug the fax unit, always wait at least 5 seconds before you plug it in again. Always unplug before you move the fax.

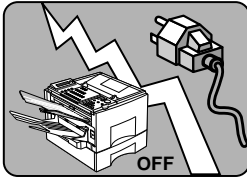

- During electrical storms, disconnect the plug from the power outlet. The fax can hold documents in the memory for up to 12 hours.

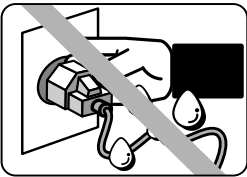

- Before you attach or remove the plug from the power outlet, make sure your hands are dry.

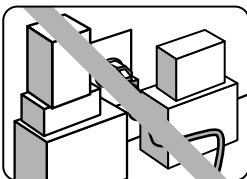

- Do not stack boxes or furniture around the power outlet. Keep the area open so you can reach the outlet quickly. If you notice anything unusual (smoke, strange odors, noises) around the fax, turn the fax off immediately and unplug it. Call for service.

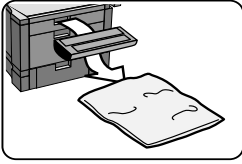

- Before you transport the fax unit, remove the cartridge. To protect the cartridge from bright light, cover it with its original protective bag or a cloth.

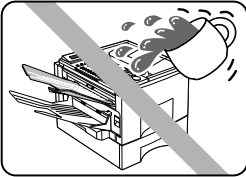

- Keep liquids, cleaners, and other solvents away from the fax unit. Keep metal pins, paper clips, staples and other objects away from the fax. If something falls into the fax unit, remove the plug from the power outlet, and call for service.

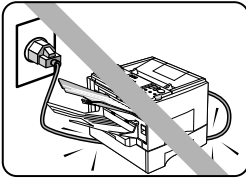

- Do not set the fax unit, other equipment, or furniture on the power cord. Never knot the power cord or wrap it around another object.

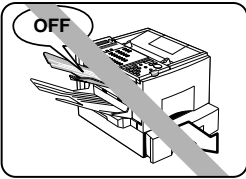

- To avoid paper jams, never unplug the power cord, open the printer cover or remove a paper cassette during printing.

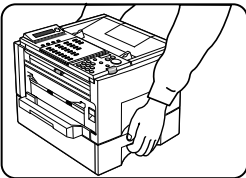

- When you lift the fax, hold it by the front and back sides. Never try to lift the fax by gripping the side paper cassette and the feeder right cover.
- When you lift the fax unit, tilt it back slightly to prevent the front cassette from sliding out of the fax unit.
- Never grip and lift the fax by the feeder right cover. Always grip and lift by the front and back sides as shown in the illustration.

# Unpacking: Have You Got Everything?

As you unpack the fax, save the carton and packing material in case you want to move or ship the fax unit in the future. Ask someone to help you remove all items from the box. You will need someone to hold the box while you lift the fax unit and its protective packaging out of the carton.

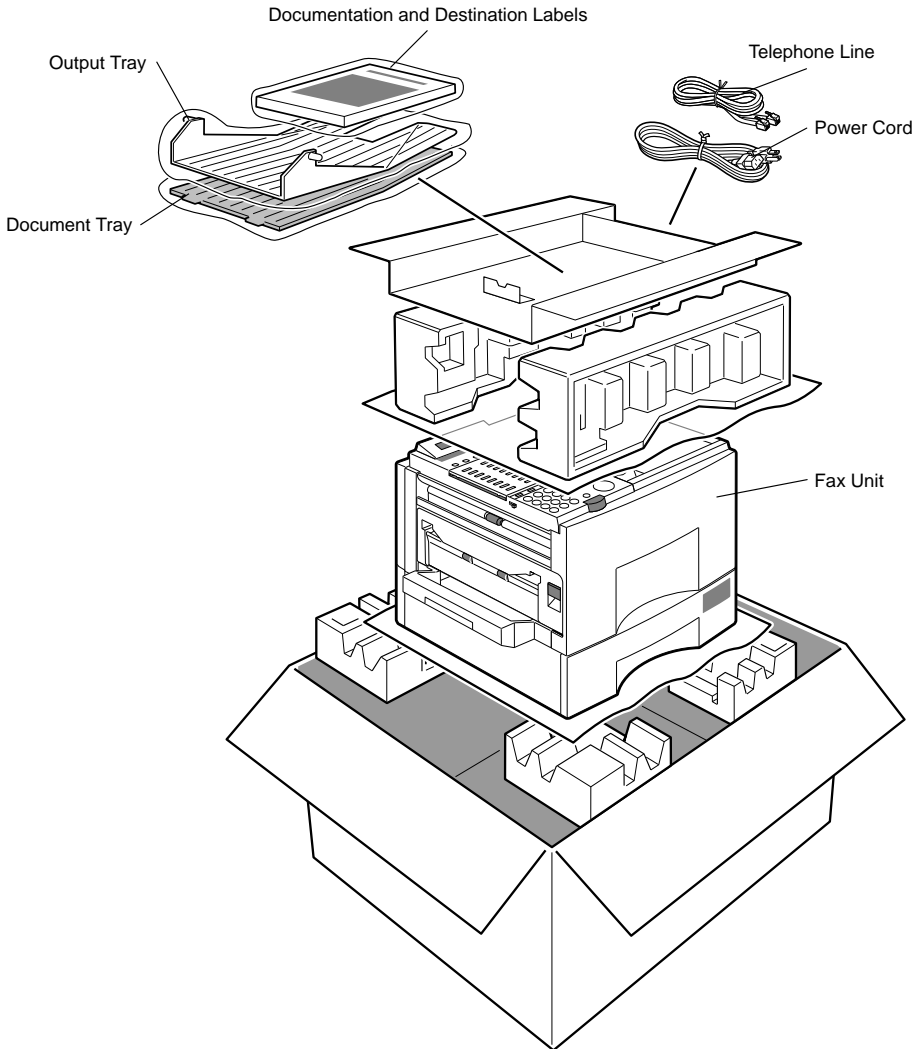

Check each item against this list as you remove it from the box.

- 1 Fax machine
- 1 Document tray
- 1 Output tray
- 1 Side paper cassette (multi-size, 100-sheet capacity)
- 1 Front paper cassette (A4-size, 500-sheet capacity)
- 1 Power cord
- 1 Telephone line
- 4 Sheets of destination labels
- 1 User's Guide

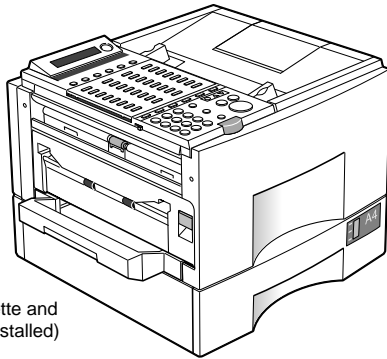

**Fax unit**  
(with side cassette and  
front cassette installed)

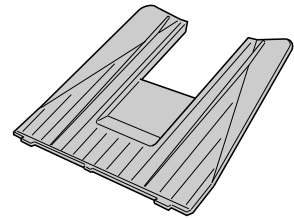

**Document tray**

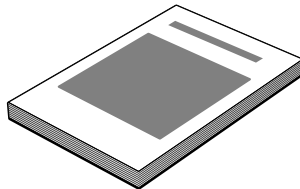

**User's Guide**

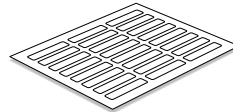

**Destination labels x 4**

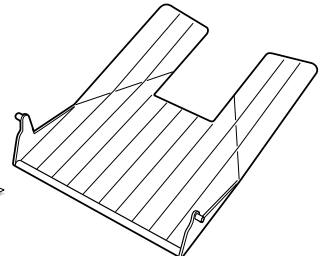

**Output tray**

**Power cord**

**Telephone line**

### **Options**

- HANDSET KIT
- G3 FAX OPTION MEMORY VII (2 MB) (H11-4711)
- G3 FAX OPTION MEMORY VII (4 MB) (H11-4721)
- Verification Stamp Unit 1 (H12-3162)
- FXL-CASSETTE FEEDER 5 (A4, 500-sheet capacity) (H12-3153)

### **Supply**

- Canon FX4 Toner Cartridge



# Parts of the Fax

Take a few moments to look over the fax and become familiar with its parts.

## Front View

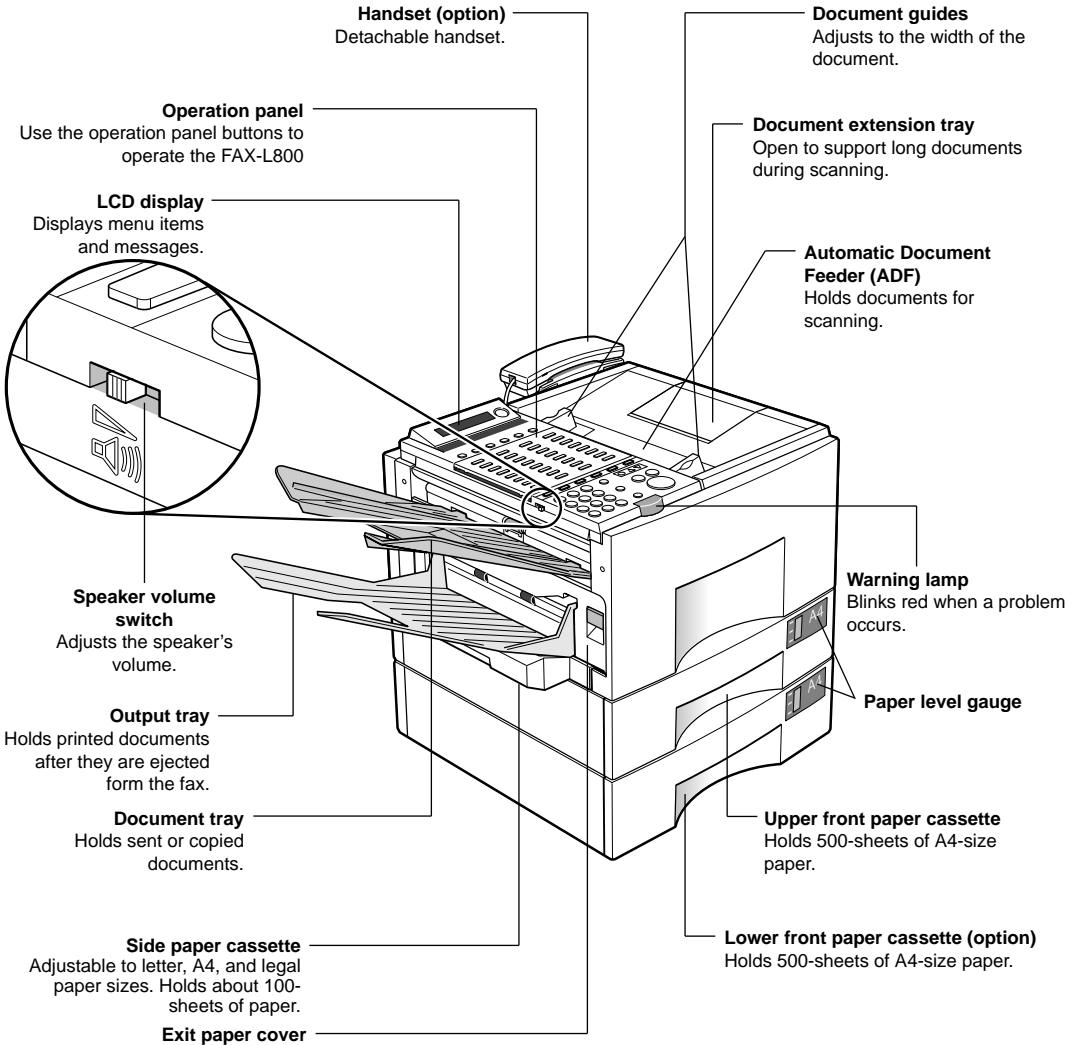

## Rear View

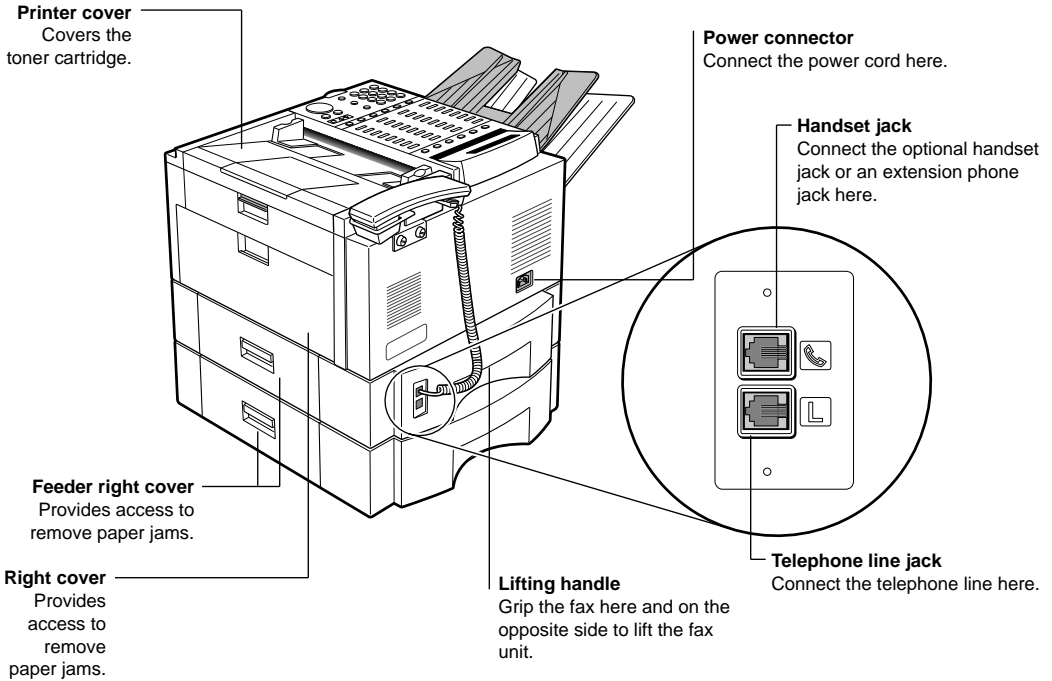

## Handset (option)

Depending on countries, the handset type 1 or type 2 is optional.

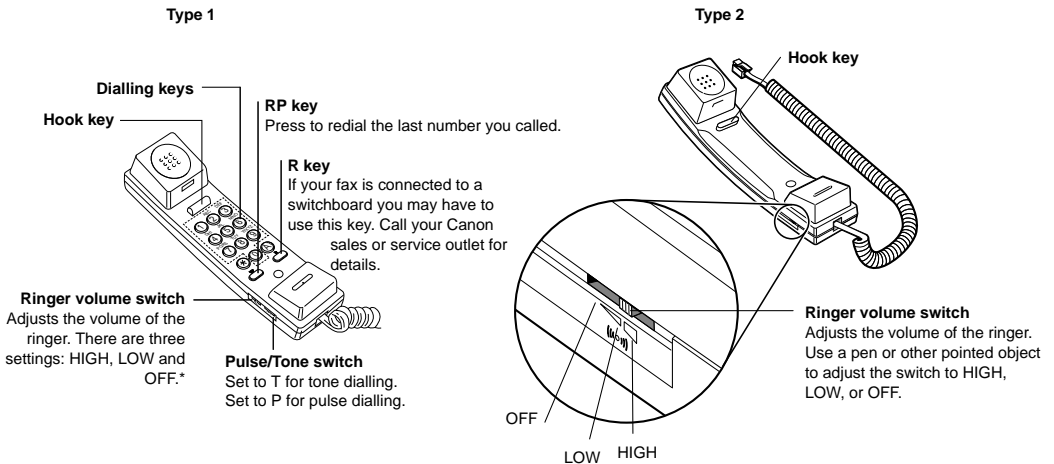

\* HIGH, MIDDLE, or LOW in some areas.

# Removing the Shipping Material

All shipping materials must be removed. Shipping materials are attached inside the fax unit and on the front paper cassette to protect delicate parts from vibration during shipping.

## Removing the Shipping Tape

Remove all the shipping tape from the unit.

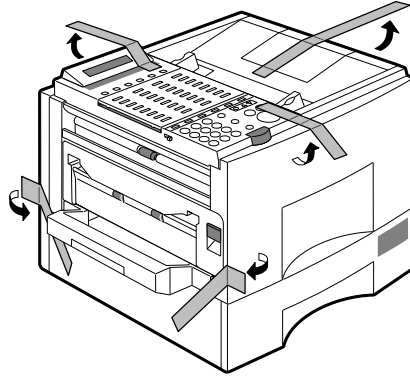

## Removing the Spacers Inside the Fax Unit

1. Pull up the release lever to unlock the printer cover and lift it to open.

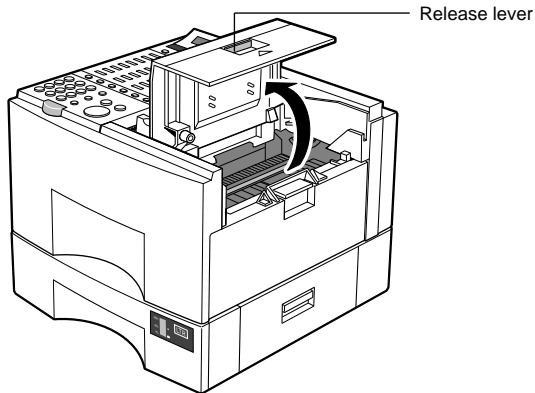

2. Remove the left and right spacer.

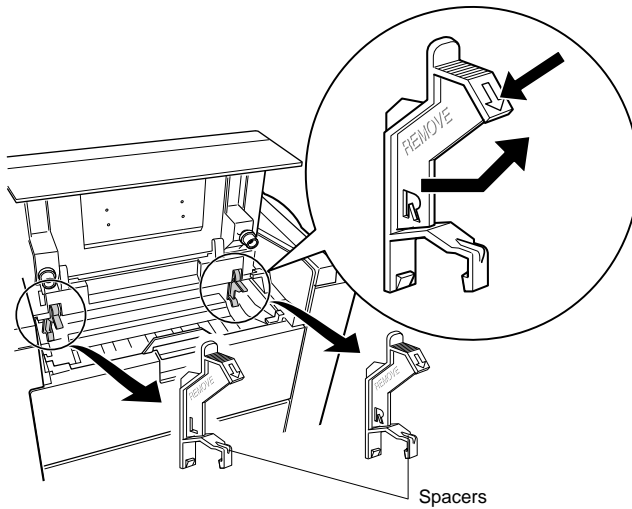

3. Close the cover.



---

Save the left and right spacer. You may want to insert them again if you have to transport the fax unit.

---

## ***Removing the Styrofoam Sheet from the ADF***

1. To open the Automatic Document Feeder (ADF), grip the operation panel and gently pull the panel up until it opens partially.
2. Remove the styrofoam sheet.

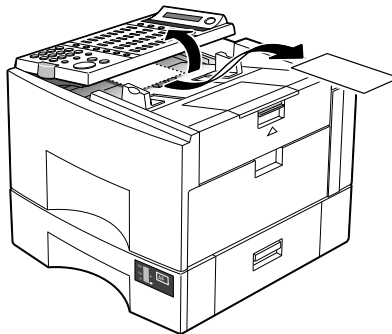

3. Gently push the operation panel shut until it clicks.

## Removing the Orange Lock Plate from the Front Paper Cassette

1. Open the front paper cassette and remove it from the fax unit.

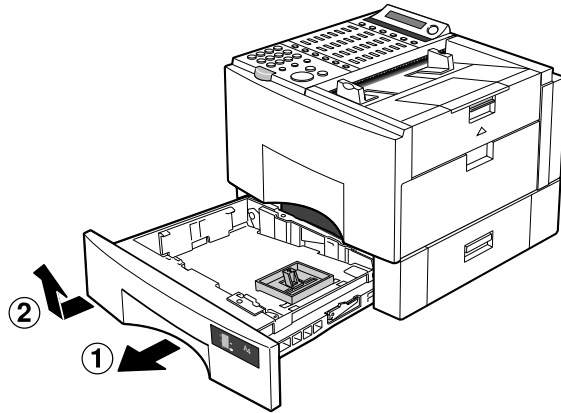

2. Set the front paper cassette down on a flat, stable surface.
3. With your right hand hold the orange lock plate and use your right thumb to pull up the release lever and slide the plate to the left.

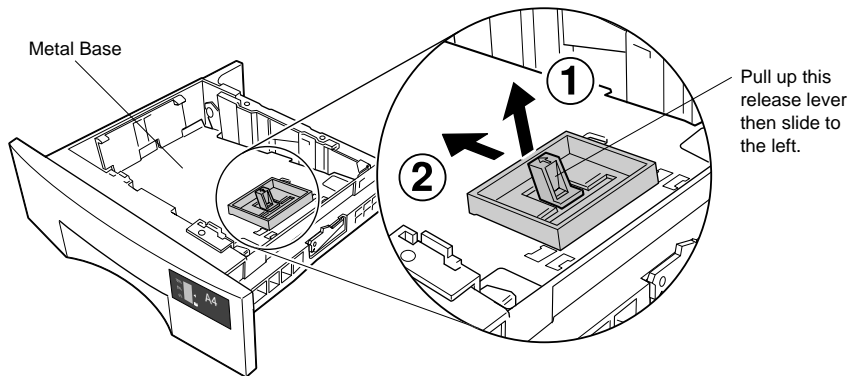

---

Pushing the metal base down hard might break the cassette.

---

4. After the orange lock plate releases, lift it up.

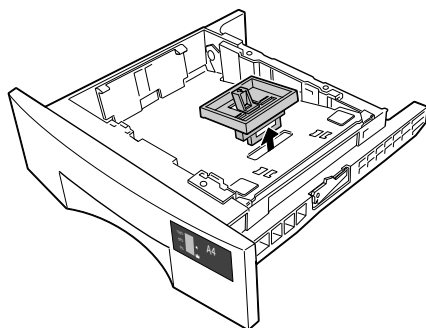

5. Insert the paper cassette in the fax unit. (→2-25)
6. Repeat this procedure for the other front paper cassette if you have two front paper cassettes installed on the fax unit.



---

Save the orange lock plate of the paper cassette. You may want to insert it again if you have to transport the fax unit.

---

## Removing the Protective Sheets

The LCD on the operation panel and the paper level gauge on the front paper cassette are covered with plastic sheets to protect them during shipping. This protective material should be removed before you use the fax unit.

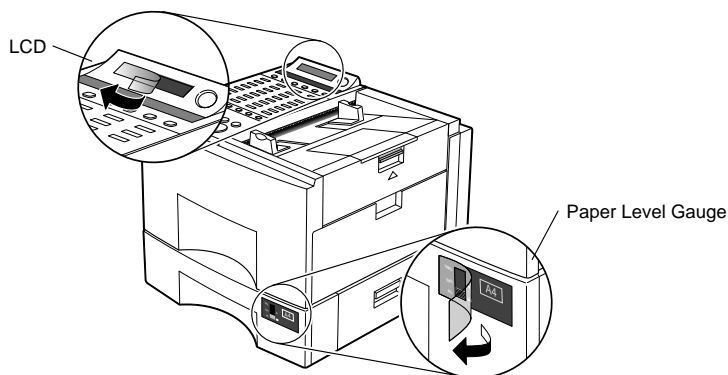

1. Remove the plastic sheet covering the LCD on the operation panel.
2. Remove the plastic sheet covering the paper level gauge on the front paper cassette.
3. If you have two front paper cassettes, remove the plastic sheet covering the paper level gauge on the other front paper cassette.



---

The second front paper cassette is an option. (→2-10)

---

## Assembling the Fax

Follow the instructions in this section to assemble the fax and prepare it for full operation.

### Installing the Toner Cartridge

Install only a Canon FX4 Toner Cartridge in your fax machine.



---

Installing any other type of cartridge in this fax unit could damage the fax unit and void your warranty. Leave the toner cartridge in its protective bag until you are ready to install the cartridge. Handle the toner cartridge carefully. (→15-17)

---

1. Pull up on the lever above the ▲ mark to open the printer cover.

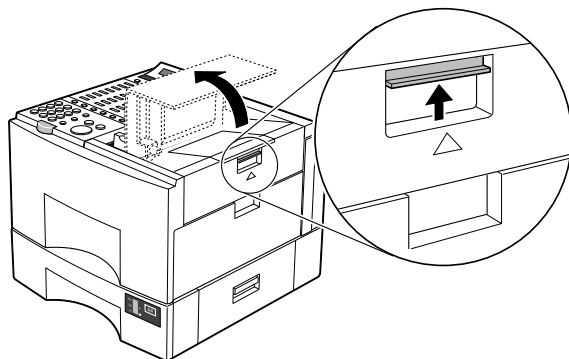

2. Remove a new toner cartridge from its protective bag.

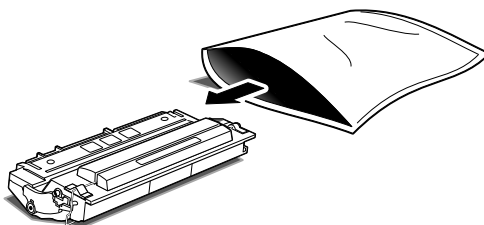

Save the protective bag. You can use it later to cover the cartridge if you have to remove it from the fax machine.



---

Save the protective bag and all other shipping material. You will need this material later when you dispose of the cartridge after it has run out of toner. (→15-15)

---

3. Hold the cartridge by the ends and rotate it slowly in the direction of the arrows five or six times to distribute the toner evenly inside the cartridge.

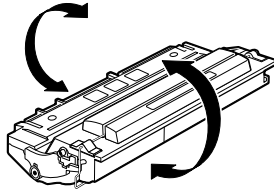

4. Place the new cartridge on a stable, flat, clean surface. As you steady the cartridge with one hand, remove the seal by gently pulling the plastic tab with your other hand. Use a firm, even pull to avoid breaking the seal.

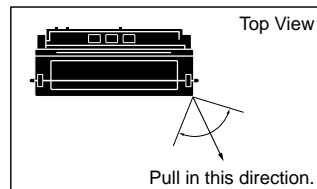
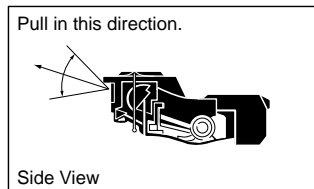
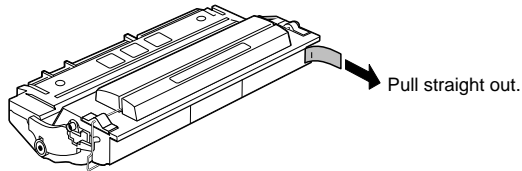

5. To avoid pinching your fingers between the toner cartridge and fax unit, grip the cartridge as shown below.

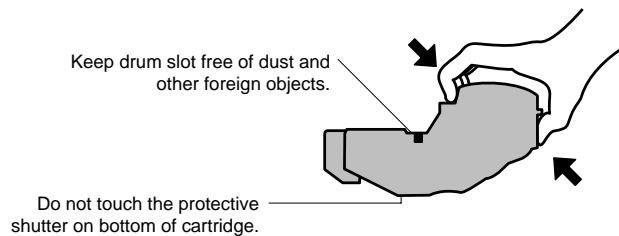



6. Load the cartridge in the direction indicated by the arrow. Gently slide the cartridge into the printer area until it is down inside the fax unit and level.

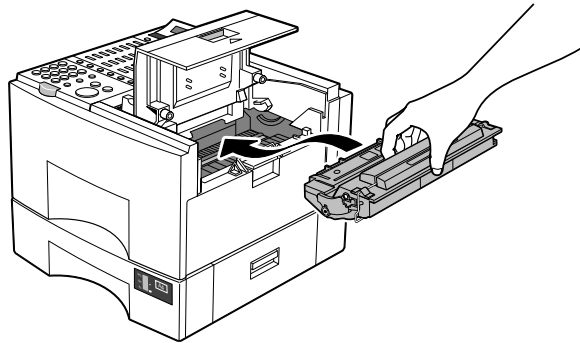

7. Shut the printer cover until you hear it lock.

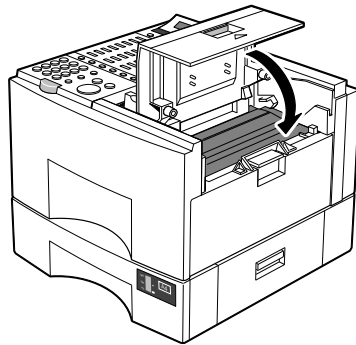

- The fax unit will not operate if the printer cover is not closed completely. If the printer cover is open (and the fax unit is plugged in), you will see a message:

CHECK PRINTER COVER

Open the cover again and make sure the toner cartridge is level. Then shut the printer cover again until you hear it lock.

## Attaching Trays

1. Attach the output tray to the side of the printer.
2. Attach the document tray to the side of the fax unit, just above the output tray.

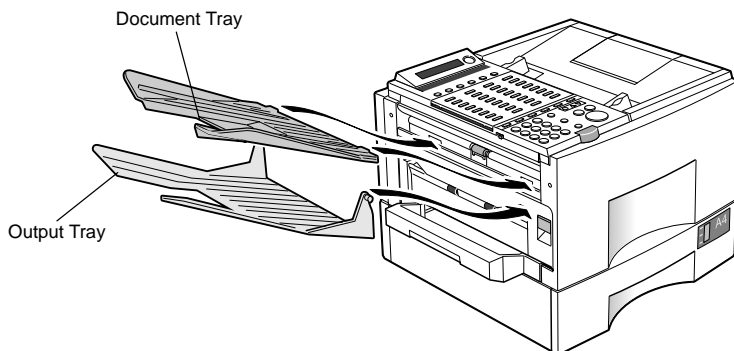

## Connecting the Handset (an option)



---

A telephone handset is available as an option for the fax machine. This handset is for use with Listed Canon Facsimile machine only.

---

1. Fit the handset cradle over the holes.
2. Fasten the handset cradle with the screws provided.

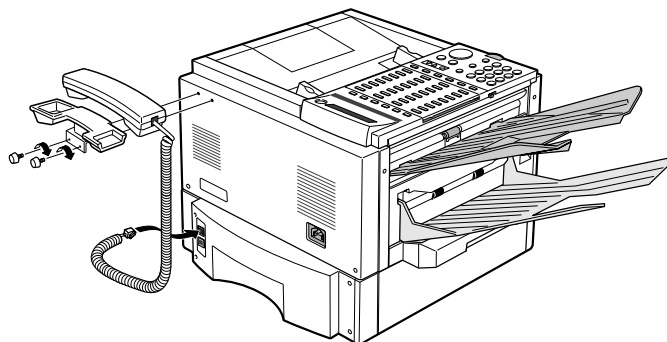

3. Connect the end of the handset connector cord to the jack marked with the handset icon (📞).

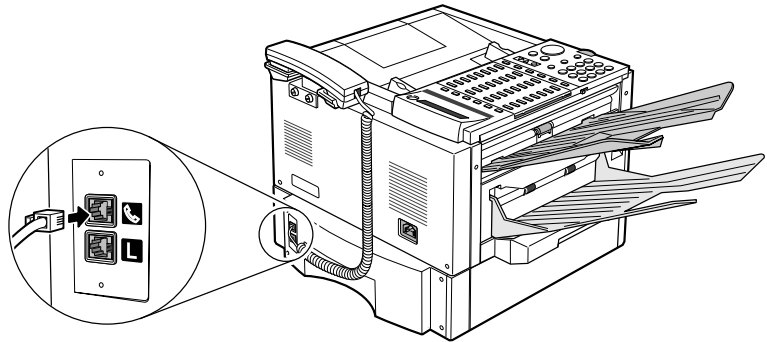

4. Place the handset on the handset cradle.

## **Connecting the Telephone Line**

1. Connect one end of the supplied telephone line to the fax jack marked **L**.

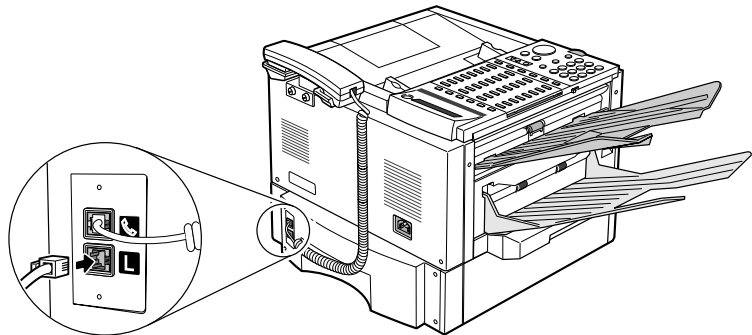

2. Connect the other end of the telephone line to your wall telephone jack.



---

To avoid electrical shock, connect the telephone line to the fax first. Then connect the line to the wall telephone jack.

---

## Connecting an Extension Phone

To connect an extension phone to the fax, you have to use the handset jack.



---

Only one jack is provided to be used with the optional handset or an extension phone. A separate jack is not provided for an extension phone.

---

1. Connect the extension phone cord to the jack marked with the handset icon .

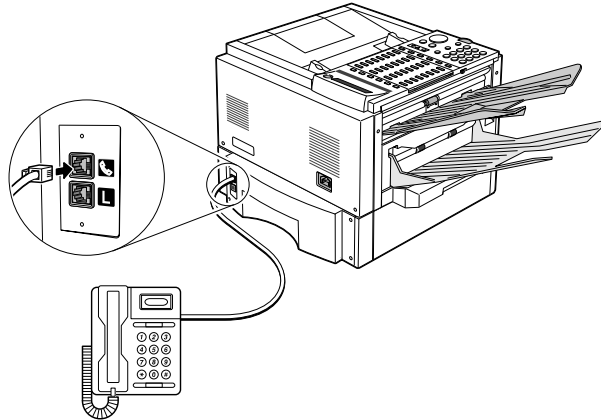

## Loading Paper and Installing the Paper Cassettes

Before you load paper, follow these general guidelines:

- The side paper cassette can be adjusted to accept letter, legal, or A4 size paper.
- Use Canon standard 64-90 g/m<sup>2</sup> weight paper.
- To avoid paper jams, do not load wrinkled or curled paper in the paper cassette.
- To avoid paper curling, do not open paper packs until you are ready to load the paper in the fax unit. Store unused paper from opened packs in a cool, dry location.
- Let the paper run out before you refill the paper cassette. Avoid mixing new paper with paper remaining in the paper cassette.

## Loading Paper in the Side Paper Cassette

1. Pull out the side paper cassette.

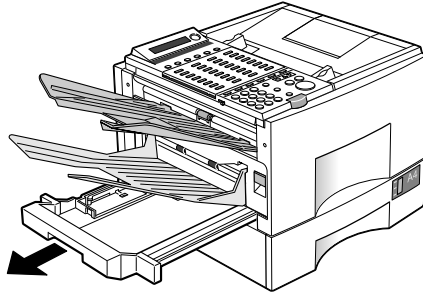

2. Check the selector inside the side paper cassette and make sure it is set for the size of the paper you are loading.

If the setting is correct, go on to step 3.

-or-

To set the paper cassette for a different paper size, slide the selector to the correct position.

To release the guide, push it gently toward the center of the paper cassette. Gently push it up or back until the tip is just below the line of the setting you want. Then push it out toward the side of the paper cassette to lock it.

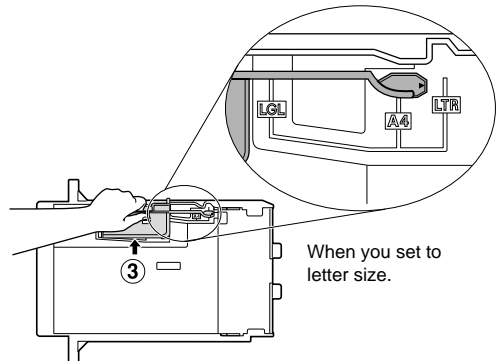
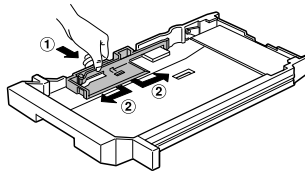

3. The side paper cassette holds approximately 100 sheets of paper. Before you load paper into the side paper cassette, tap the edges of the stack to make sure the leading edge and sides of the stack are even.

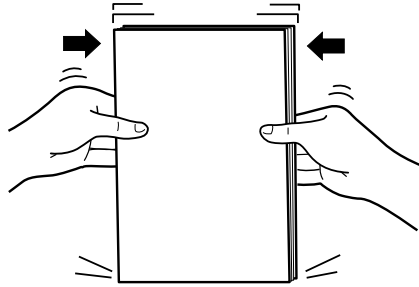

4. Load the paper into the side paper cassette. Slide the edge of the stack under the front tabs of the paper cassette.

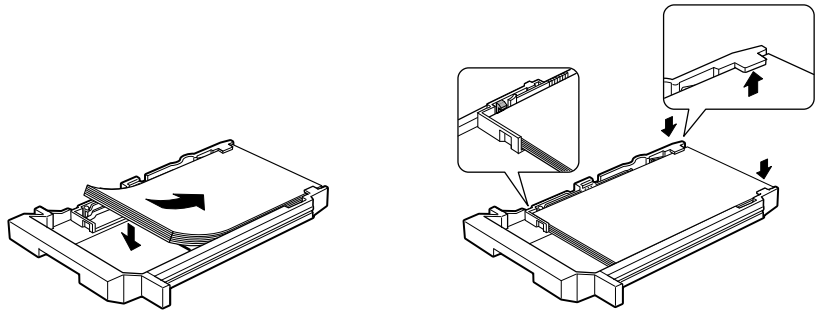

Make sure the paper stack is not higher than the load limit marks (▼▼▼) on the left side of the paper cassette.

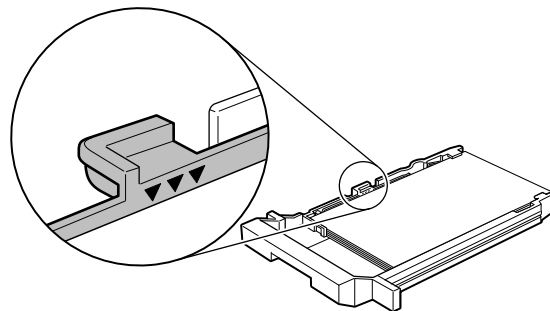

Check the corners of the stack and make sure they are below the tabs at the front end of the paper cassette.

5. Gently insert the side paper cassette into the fax until you hear it click.

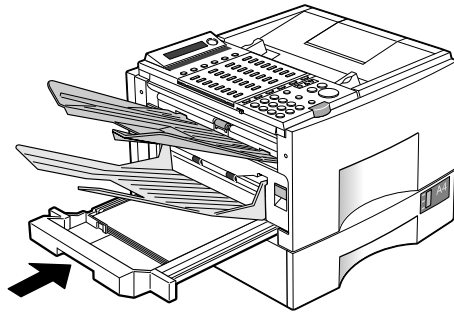

---

Inserting the side paper cassette carelessly may cause paper jams and distorted images. If you pull the side paper cassette out with paper remaining in the paper cassette, make sure no paper is out of the paper cassette and that there is no loose paper inside the fax unit.

---

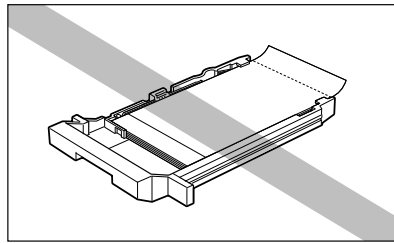

### **Loading Paper in the Front Paper Cassette**

1. To pull out the front paper cassette, lift it up at a slight angle then pull it up and out.

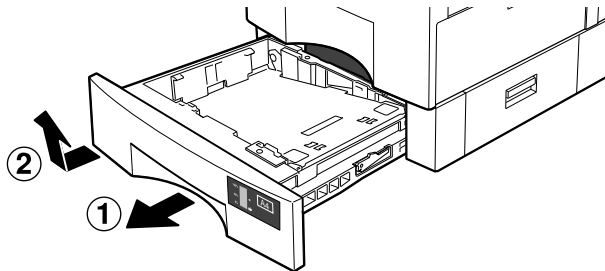

2. Before you load a stack of paper in the front paper cassette, tap the leading edge of the paper stack on a flat surface so the edges are evenly aligned.

3. Set the paper stack into the front paper cassette.

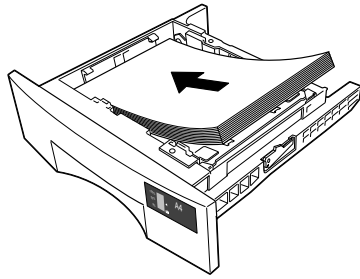

---

Before loading 500 sheets, divide the stack into approximately equal thirds about 1,5 cm thick. Then load each stack separately. The paper stack should not be higher than the load limit marks (▼▼▼) on the side of the paper cassette. Make sure the stack is below the tabs at the front of the paper cassette.

---

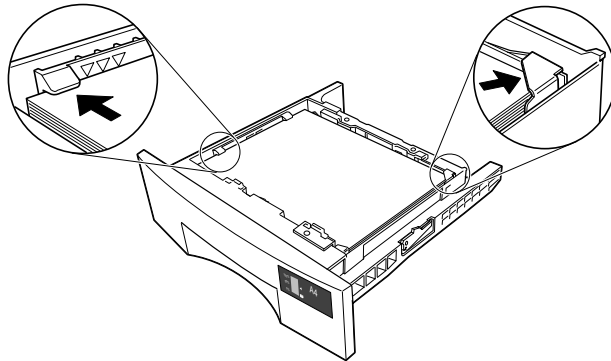

Check the front corners of the stack and make sure they are below the tabs.

4. Gently insert the front paper cassette into the fax unit until you hear it click.

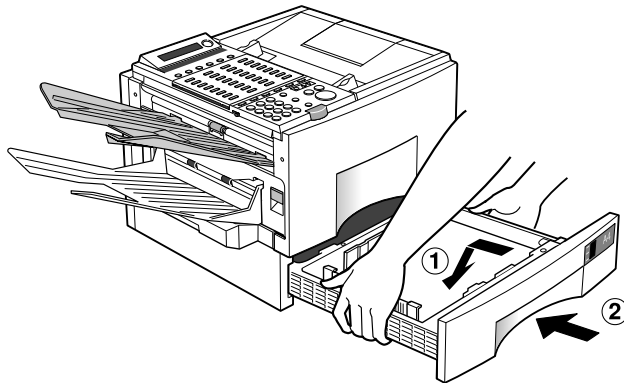



- The paper level gauge on the front paper cassette tells you the level of the current paper supply without opening the paper cassette. When you see the paper level gauge drop, make sure you have a supply of paper on hand to fill the cassette. When you see the SUPPLY REC. PAPER message, re-fill the cassette.

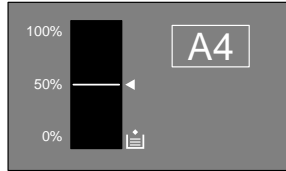

## Turning on the Power

1. Connect the power cord to the power receptacle on the rear of the fax unit.
2. Connect the other end of the power cord to the power source.



The fax must be connected to a properly grounded, three-prong 230 V AC outlet.

After you connect the power cord to the power source, the fax LCD display will light. There is no power switch on the fax unit.

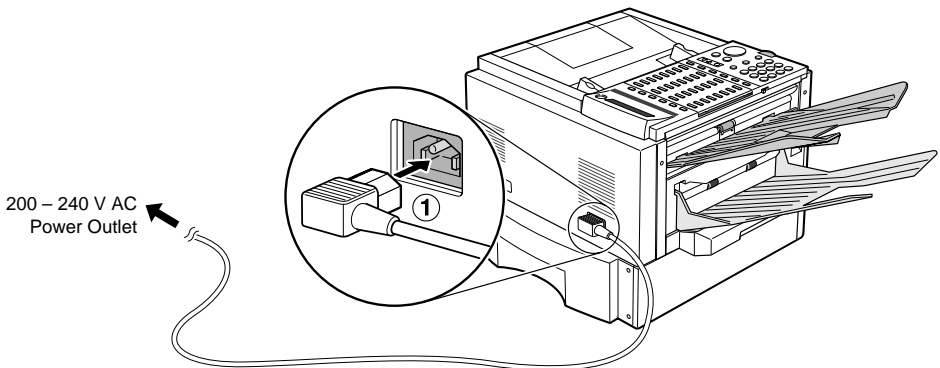

It will take a few seconds for the unit to warm up.

PLEASE WAIT

The unit has warmed up and is ready to use when you see the date and time display.

26/12 '97 FRI 12:20

When the date is displayed on the LCD, the fax is in the *standby mode* and ready for normal operation. If the alarm starts blinking red, wait for one of the following messages to appear.

---

REPLACE CARTRIDGE	The toner cartridge has run out of toner. Replace the toner cartridge.
CHECK PRINTER COVER	The printer cover is not closed completely. If it does not close easily, do not force it. Remove the toner cartridge, and insert it again. Make sure it is sitting level inside the fax machine then close the printer cover again. And make sure the toner cartridge is installed in the fax unit.
SUPPLY REC. PAPER	One of the paper cassettes is empty or one of the paper cassettes is not seated correctly inside the fax machine. Remove each cassette. Make sure the stack of paper is below the tabs and insert the paper cassette again. Push the paper cassettes all the way in until they lock in place.

---

When ENERGY SAVER is ON, the fax switches to the energy save mode in a specified length of time (→3-19, 16-26). The ENERGY SAVER indicator lights red and ENERGY SAVER appears in the LCD display.

ENERGY SAVER

ENERGY SAVER



To restore to the standby mode, press the ENERGY SAVER button.

# Chapter 3

## Getting Started

---

This chapter describes some important settings that you should perform before you use the fax.

Before you use the fax you should set the correct date and time, register the fax unit telephone number, and register the unit name (your personal name or a company name). If these tasks have been done for you, then you may want to enter your own sender name. (→3-17)

First, we will describe the operation panel buttons and give a brief introduction to the basic procedures for browsing through the menus and finding the items you want. Then we will guide you step by step through the basic procedures that must be performed before you use the fax for the first time.

Operation Buttons (One-touch panels closed) .....	3-2
Operation Buttons (One-touch panels open) .....	3-4
Using the Menus and Buttons .....	3-5
General Guidelines for Registering Information .....	3-5
Using the Menu .....	3-5
Entering Names for Registration .....	3-7
Menu Button Summary Table .....	3-8
Checking and Setting the Telephone Line .....	3-10
Registering Required Sender Information .....	3-11
What is Sender Information? .....	3-12
Registering the Sender Information .....	3-13
Registering Sender Names .....	3-17
Registering a Sender Name .....	3-17
Changing or Erasing a Sender Name .....	3-18
Using the Energy Saver Mode .....	3-19
Turning the Energy Save Feature ON .....	3-19
Returning to the Full Power Mode .....	3-21

# Operation Buttons (One-touch panels closed)

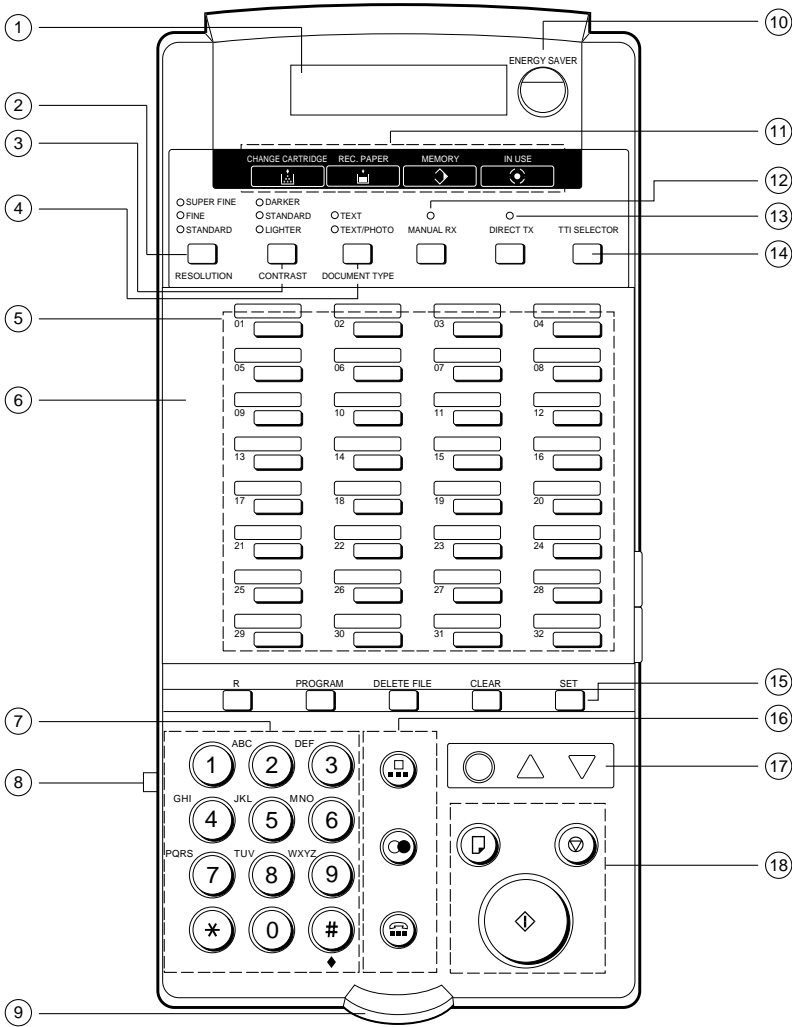

- ① **LCD Display**  
Displays messages and prompts during operation. Displays selections, text, numbers and names when registering information.
- ② **Resolution**  
Sets the resolution for documents you send.
- ③ **Contrast**  
Adjusts the lightness/darkness of documents you send or copy.
- ④ **Document type**  
Adjusts quality for documents with only text or with both photos and text.
- ⑤ **One-touch Speed Dialling buttons**  
Dial numbers registered under One-touch Speed Dialling buttons.
- ⑥ **One-touch Speed Dialling panels**  
The first panel displays buttons 01-32. Open the first panel to access buttons 33-64. Open the second panel to access buttons 65-72 and the registration buttons.
- ⑦ **Numeric keypad**  
Use the buttons on the numeric keypad to enter phone numbers when dialling. These buttons also enter text, numbers, and symbols when registering names and numbers.
- ⑧ **Speaker volume switch**  
Adjusts the volume of the speaker.
- ⑨ **Alarm**  
Blinks red after a problem occurs. The problem is described by a message in the LCD display above.
- ⑩ **Energy saver**  
Switches the fax out of the energy save mode.
- ⑪ **Change cartridge**  
Lights when toner in the toner cartridge runs low. Replace the toner cartridge.  
**Rec. paper**  
Lights when the paper cassette runs out of paper. Refill the cassette with paper.  
**Memory**  
Lights when there are documents in the memory.  
**In use**  
Lights when your fax is using the telephone line.
- ⑫ **Manual RX**  
Switches the fax between the auto and manual receive mode.
- ⑬ **Direct TX**  
Sets the fax in the direct sending mode so you can send a document ahead of other documents stored in the fax memory. Direct sending scans a document and sends it immediately without storing the document in the memory.
- ⑭ **TTI selector**  
Enters a registered sender's name to appear at the top of the document you are sending.
- ⑮ **R**  
Press to dial an outside telephone number, or an extension number, when the fax is connected through a switchboard (PBX).  
**Program**  
Registers multi-step setting normally done by pressing buttons on the operation panel so you can do them at the press of single button.  
**Delete file**  
Deletes documents waiting in memory for sending.  
**Clear**  
Clears an entire entry during information registration.  
**Set**  
Selects a menu item during data registration.
- ⑯ **Coded dial**  
A press on the button followed by a three-digit code dials the telephone number registered for Coded Speed Dialling under that three-digit code.  
**Redial**  
Redials the previous number dialled manually with the buttons on the numeric keypad.  
**Hook**  
Allows you to dial, even with the handset still in the handset rest.
- ⑰ **Directory**  
Allows you to search for fax/telephone numbers by the name under which they are registered for speed dialling and then use the number for dialling.
- ⑱ **Copy**  
Copies a document.  
**Stop**  
Cancels sending, receiving, data registration, and other operations and returns the fax to the standby mode.  
**Start/Scan**  
Starts sending, receiving, copying and other operations.

# Operation Buttons (One-touch panels open)

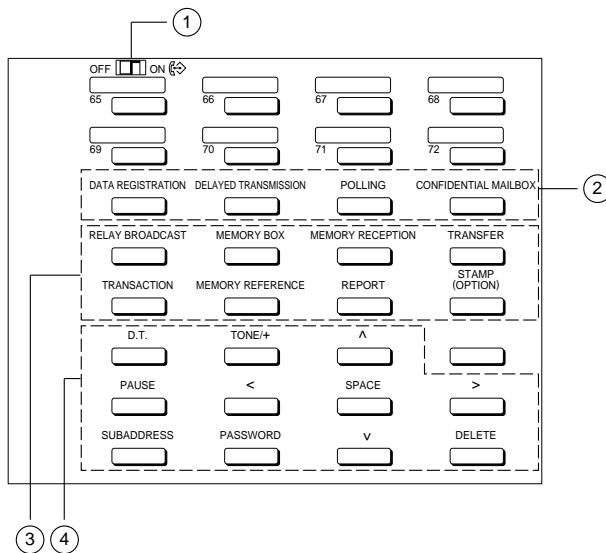

① **Do not touch this switch. (Must be set off.)**

② **Data registration**  
Starts data registration for speed dialling, sender information, and other important settings for sending and receiving.

**Delayed transmission**

Sets a time for delayed sending.

**Polling**

Sets a document for polling sending, and also used for polling receiving.

**Confidential mailbox**

Sets a document for sending to a confidential mailbox so you can print documents received in the mailbox.

③ **Relay broadcast**

Sets a document to be sent to another fax for relay sending.

**Memory box**

Sets a document to be stored in a memory box, or opens a memory box so you can print documents received in the memory box.

**Memory reception**

Switches the fax in and out of the memory lock mode. In the memory lock mode, the fax stores all documents it receives in the memory.

**Transfer**

Switches the fax in and out of transfer mode. In the transfer mode the fax unit sends all documents it receives to another fax machine at your home or another office.

**Transaction**

Displays information about previous sending and receiving transactions.

**Memory reference**

Performs operations with documents currently stored in the memory, including printing a list of documents, printing a documents, sending a document to another destination, or deleting a document.

**Report**

Prints reports about information registered in the fax.

**Stamp (option)**

Switches the fax in and out of the stamp mode. In the stamp mode, the fax marks all documents scanned for sending in memory mode or direct sending mode. If you want to use the stamp feature, call your authorized Canon dealer and request installation of this option.

④

**D.T.**

Press to confirm the dial tone when registering a telephone number.

**Tone/+**

Connects to information services that accept tone dialling only, even if you are using a rotary pulse line or enters a plus sign in a fax number. And enters a plus sign when registering your fax number.

**^ / v Search buttons**

Scrolls the display so you can see other options and selections in the menus during data registration.

**Pause**

Enters pauses between digits or after the entire phone number when dialling or registering facsimile numbers.

**< > Cursor buttons**

Moves the cursor left or right during data registration.

**Space**

Enters a space between letters and numbers on the LCD display when you are registering information

**Subaddress**

Allows you to enter an ITU-T subaddress so you can send a document with a subaddress.

**Password**

Allows you to enter an ITU-T password so you can send a document with a password.

**Delete**

During a step when you are registering or entering a number, press this button to delete the number. (This button deletes number entries only).

# Using the Menus and Buttons

This section provides a brief overview on how to use the menu buttons to open menus, make selections, and register data.

## General Guidelines for Registering Information

Always keep these points in mind while you are using the menus:

- If you pause and do not press a button for 60 seconds, the fax returns to the standby mode automatically. You must then start the procedure again from the beginning.
- If your fax is set to manual receiving and the fax rings while you are registering information, pick up the handset. If you hear a slow beep tone, the other party is trying to send you a document. Press STOP and press START/SCAN to receive the document.

## Using the Menus

The fax employs a menu system you can use to register important information or to set up important features. Here we will describe how to display and open these menus. The content and purpose of each menu is described in another chapter. (→16-3)



1. Open both One-touch Speed Dialling panels so you can see the operation panel buttons.

DATA REGISTRATION



2. Press DATA REGISTRATION.

REGISTRATION  
1.DATA REGISTRATION

SET



3. Press SET.

DATA REGISTRATION  
1.USER SETTINGS



4. Press the search buttons to display the name of the next or previous menu title.

DATA REGISTRATION  
1.USER SETTINGS

DATA REGISTRATION  
7.SYSTEM SETTINGS



---

Note that displaying menu names with the search buttons is rotational. If you press  $\vee$  with the last menu name displayed, the display rotates to the first menu name. If you press  $\wedge$  with the first menu displayed, the display rotates to the last selection.

---

### ***To Open a Menu and Select an Item***

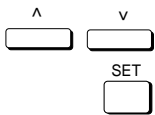

Press the search buttons until you see the name of the menu you want to open, then press SET.

Press the search buttons to browse through the menu items then press SET to go to the next level.

### ***To Return to the Previous Level***

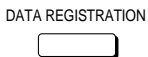

Press DATA REGISTRATION to return to the previous level so you can continue browsing. If you continue to press DATA REGISTRATION you will return to the standby mode.

### ***To Return to Standby Immediately***

Press STOP to return to standby.



---

If you do not press a button for 60 seconds, the fax will automatically return to standby.

---



## Entering Names for Registration

When you come to a step that requires entering a name for data registration, follow the procedure below.

In a display that requires a name entry, the uppercase letter, lowercase letter or number in the upper right corner of the LCD display tells you the entry mode.

UNIT NAME	:A
—	



1. Press \* to change the entry mode.

Display	Entry mode	What it does
:A	Uppercase letter	Allows you to enter uppercase letters. You can also press # to enter a symbol.
:a	Lowercase letter	Allows you to enter lowercase letters. You can also press # to enter a symbol.
:1	Number	Allows you to enter numbers. You can also press # to enter a symbol.

The numeric keypad buttons are clearly labelled with one number and some letters.

Numeric keypad	Uppercase :A	Lowercase :a	Number :1
1			1
2	ABCÁÄÅĂĂĂÆÇ	abcâãäåââæç	2
3	DEFÐËËËË	defðëëëë	3
4	GHIÍÍÍÍ	ghiíííí	4
5	JKL	jkl	5
6	MNOÑÕÖÖÖÖ	mnoñõöóóó	6
7	PQRS Þ	pqrs þ	7
8	TUVÛÚÚÚ	tuvûúúú	8
9	WXYZÝ	wxyzý	9
#	-.*#!“,,: ^`_=/!'?\$@%&+()[]{}<>		



2. Press the appropriate button to enter the letter or number.

Keep pressing the button until the letter you want appears.

If you go past the letter you want, you will have to keep pressing the button until it appears again.

3. If the next letter you want to enter is under another button, just press that button to move the cursor right and enter the first letter of that group with a single button press.

-or-

If the next letter you want to enter is under the same button you just pressed, press > to move the cursor to the right one space. Then keep pressing the button again until the letter you want appears.

- You can also enter symbols. Just press # until you see the symbol you want, then press > to move the cursor one space to the right.
- To enter a space, press SPACE.

### ***To Correct a Mistake***



Use the cursor buttons to move the cursor left or right to position it under the incorrect letter. Then enter the correct letter.

-or-

Press CLEAR to delete the entire entry so you can start again.

## ***Menu Button Summary Table***

Whenever you come to a step where you must enter a number or name for data registration – in this section or in any part of this User's Guide – refer to the table below.

To see the buttons below, open both One-touch Speed Dialling panels.

### **Buttons for registering information**

---

<p>∧ ∨</p>	<p>The search buttons display the next or previous menu item.</p> <p>Press ∨ to display the next item of the menu. If you press ∨ when the last item is displayed, the display rotates to the first item on the menu.</p> <p>Press ∧ to display the previous item of the menu. If you press ∧ when the first item is displayed, the display rotates to the last item on the menu.</p>
------------	---

---

### Buttons for registering information (con'td)

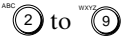
SET	Press SET to select the current item and display the next level of the menu.
*	Switches the entry modes.
:A	Uppercase letter entry mode. You can enter uppercase letters only.
:a	Lowercase letter entry mode. You can enter lowercase letters only.
:1	Number entry mode. You can enter numbers only.
	More than one letter is assigned to a button. Press * to enter the text entry mode then press the button for the letter you want to enter. If the letter you want to enter is not displayed first, keep pressing the button until it appears. If the next letter is under another button, just press that button to enter the first letter of the group and then keep pressing the button until the letter you want appears.  -or-  If the next letter is under the same button, press > to move the cursor right one space then press the button again to enter the first letter of the group. Keep pressing the button until the letter you want appears.
< >	The cursor buttons move the cursor left or right.
#	Press # to enter a symbol. You can enter symbols in the text or number entry mode. Keep pressing # until the symbol you want is displayed then press > to move the cursor to the right. You can enter these symbols: -.*#!“”;;: ^ ` _=/!?'\$@%&+()[]{}<>
SPACE	Enters a space between letters or numbers. You may enter spaces in telephone numbers – they do not affect dialling. Pressing SPACE also deletes the character at the cursor position.
DELETE	Deletes the number from the right digit.
CLEAR	Clears the entire entry if you want to erase it and start again.
STOP	After you are finished making settings or registering information, press STOP to return to the standby mode.

# Checking and Setting the Telephone Line

If you are not sure what type of telephone line you have, check with your local telephone company. To operate the fax you must know if the fax is connected to a tone or rotary pulse line. The fax can be set to operate with either type of telephone line. The fax unit is set to operate through a tone line without making adjustments.

Use this procedure to switch the fax set-up between tone and pulse dialling.



DATA REGISTRATION



SET



SET



^



v



SET



1. Open both One-touch Speed Dialling panels. Then press DATA REGISTRATION.

REGISTRATION  
1.DATA REGISTRATION

2. Press SET.

DATA REGISTRATION  
1.USER SETTINGS

3. Press SET again.

USER SETTINGS  
1.DATE & TIME

4. Press the search buttons until you see the display below.

USER SETTINGS  
11.TEL LINE TYPE

5. Press SET.

TEL LINE TYPE  
TOUCH TONE



6. Display and check the current line setting. Use the search buttons to alternate the settings.

TEL LINE TYPE  
TOUCH TONE

TEL LINE TYPE  
ROTARY PULSE



7. Display the setting you need, then press SET.



8. Press STOP to return to standby.

## ***Registering Required Sender Information***

In this section we will show you how to set up the fax so the following information prints at the top of every document you send:

- Your fax number
- Your personal name or company name
- Time and date of transmission

Your fax is already set to print this information at the top of every document you send, but you must register your fax unit's telephone number, your personal name or company name, the current date, and the current time with the features provided in the USER SETTINGS menu. (→16-4)

# What is Sender Information?

In this section we will show you how to set up the fax so the following information prints at the top of every document you send:

<p><b>DATE AND TIME</b> This is the date and time of the transmission</p>	<p>26/12 '97 14:26 FAX 833 4423 WORLD ESTATE, INC. →ADAM BOOKS, CPA P.001/002</p>
<p><b>Telephone number</b> This is your fax telephone number. You can set TX TERMINAL ID feature to set the prefix for this number as FAX or TEL. (→16-5)</p>	<div style="text-align: center;">  <p><b>WORLD ESTATE, INC.</b> West 44th Street New York, NY U.S.A. <i>Global Real Estate Consultants in the Heart of New York</i></p> </div> <p>December 28, 1995</p> <p>Dear Member,</p> <p>By now you have all had a chance to become familiar with your new Canon fax units and are ready to set up a reliable, economical communications network that offers many exciting features.</p> <p>We can save money by scanning documents in the memory and then setting the delayed timer to send all the documents at the same time later at night to take advantage of late night rates.</p> <p>Many of us are separated by long distances and reside in different time zones. We can set up the polling feature to poll and receive documents from each other when we are not in the office. For sensitive material about clients and confidential bids, we can set up and use the confidential mailbox features. We will also be able to keep down costs by limiting use of the fax to operators who know the correct department codes and passwords.</p> <p>Relay sending is another money saver. We can designate one relay fax in your area, send one transmission from the home office on the East coast and then have the document relayed to you locally</p> <p>We hope you will have these features set up in the very near future so we can enjoy more efficient, secure, and economical facsimile communications.</p>
<p><b>Unit name or sender's name</b> This is the UNIT NAME or a sender name you select with the TTI SELECTOR button when you scan the document for sending.</p>	
<p><b>Destination</b> If you dialled with a speed dialling button, the other party's name appears here.</p>	<p style="text-align: right;"><b>Page number</b></p> <p>The page number of the document. Current page/Total page* *When all pages can be scanned in the memory sending, the page total is printed.</p>



For documents that you *receive*, you can turn on the RX FOOTER feature which displays the date, time received, transaction number, and page number in the lower right corner of the document. (→16-13)

<p>26/12 '97 FRI 14:52 [TX/RX NO 5041] 001</p>
--

# Registering the Sender Information

Follow this procedure to set the current date and time, register the number of your own fax unit, and register your name or company name.

1. Open the USER SETTINGS menu.

Open both One-touch Speed Dialling panels. Then press DATA REGISTRATION.



REGISTRATION  
1.DATA REGISTRATION

Press SET.

DATA REGISTRATION  
1.USER SETTINGS



Press SET.

USER SETTINGS  
1.DATE & TIME

2. Open the DATE & TIME menu. Press SET.

DATE & TIME  
25/10 '97 11:30

3. Register the date and time.

Use the buttons on the numeric keypad to enter the day, month, and year.



DATE & TIME  
26/12 '97 11:30

Use the buttons on the numeric keypad to enter the current time.

- Use the 24-hour format to enter the time (e.g. 1:00 p.m. as 13:00).
- Just enter the new number over the old number.
- You can also use the cursor buttons to move the cursor without changing a number entry.
- To restore the previous entry, press CLEAR.

DATE & TIME  
26/12 '97 08:45

SET

Press SET.

DATE & TIME  
DATA ENTRY OK

USER SETTINGS  
2.UNIT TELEPHONE #

4. Enter the unit telephone number. The unit telephone number is the telephone number for your own fax.

SET

Press SET.

UNIT TELEPHONE #  
TEL=

Use these buttons on the numeric keypad to enter your own fax number.



#### Data entry buttons

---

0-9	Enters a number.
SPACE	Enters a space (spaces are optional).
DELETE	Deletes the rightmost digit of the number you are entering so you can enter a new digit.
CLEAR	Clears the entire entry if you want to start again.
TONE/+	Enters a plus sign (+).

---

You can register a number of up to 20 digits.

UNIT TELEPHONE #  
TEL= 123 4567

SET

Press SET.

UNIT TELEPHONE #  
DATA ENTRY OK



5. Enter the unit name.

USER SETTINGS  
3.UNIT NAME



Press SET.

UNIT NAME :A



Use the buttons on the numeric keypad to enter a name of up to 24 characters.

You can enter letters in upper or lower case and enter numbers. In the upper right corner of the display you will see the letter A. This means you are in the uppercase letter entry mode. Press the asterisk (\*) button on the numeric keypad to switch the entry mode.

**Display Press keypad buttons to enter:**

---

:A	Uppercase letter entry mode
:a	Lowercase letter entry mode
:1	Number entry mode

---

Above each button on the numeric keypad, there is a group of letters. These are the letters you can enter with the button below.



---

Each button contains the upper and lower case letters for its group of letters.

---

Press the button of the letter you want to enter. If the letter you want is not displayed first, keep pressing the button until the letter you want appears.



---

If you go past the letter you want, just keep pressing the button until you see it again.

---

**To enter a space:**

Press SPACE to enter a space.





**To enter a number:**

Press \* to enter the number entry mode (:1)



Press the appropriate button on the numeric keypad to enter a number.

SPACE



Press SPACE to move to the next column.

**To enter a symbol:**

These standard symbols are available for entry:

-.\*#!“,;: ^ ` \_ = / ' ? \$ @ % & + ( ) [ ] { } < >



Press # until you see the symbol you want.

SPACE



Press SPACE to move to the next column.

**To delete:**

If you make a mistake and want to delete the entire entry so you can start again, press CLEAR.

CLEAR



**To make a correction:**

Press the left or right cursor button to move the cursor under the letter or number you want to change.



Press a button to enter a letter or number.



```
UNIT NAME      :A
CANON DIV. #20
```

SET



When you are finished entering the unit name, press SET.

```
UNIT NAME      :A
DATA ENTRY OK
```



This completes registering all of the required sender information for your fax.

6. Press STOP to return to standby.

## Registering Sender Names

Registering alternative sender names is optional but you may want to register sender names if many people are using the fax. If each user registers his or her personal name as a sender name, they can enter their sender name to replace the UNIT NAME printed at the top of documents they send. (→3-12)



---

To enter the sender name, press TTI SELECTOR when you scan the document for sending. (→6-6)

---

### Registering a Sender Name

Follow this procedure to register sender names.

1. Open the USER SETTINGS menu. (→3-13)
2. Press the search buttons until you see the display below.



USER SETTINGS  
4.SENDER'S NAME

3. Press SET.



SENDER'S NAME  
01:

4. Press the search buttons to display the number where you want to register your name.



-or-

Use the buttons on the numeric keypad to enter the number.

- Up to 99 numbers are available. One number can accept a single name entry.
- If a name is already registered, you will see that name to the right of the number.

- Keep pressing the search buttons until you see a number with no entry.

SENDER'S NAME  
05:

SET

5. Press SET.

SENDER'S NAME :A  
05: \_

6. Use the buttons on the numeric keypad to enter a name of up to 24 characters. (→3-7)



SENDER'S NAME :A  
05:K.SMITH

When you enter the name, use the same buttons you used to enter the UNIT NAME.

SET

7. When you are finished entering the name, press SET.

SENDER'S NAME :A  
DATA ENTRY OK

SENDER'S NAME  
06:

Repeat the procedure to enter another number, or press STOP to return to standby.

## Changing or Erasing a Sender Name

1. Repeat steps 1-3 of the procedure you used to register the sender name. (→3-13)
2. Press the search buttons to display the name you want to edit or delete.

^      v  
  

SENDER'S NAME  
10:J.SMITH



3. Press SET.

SENDER'S NAME :A  
10:J.SMITH

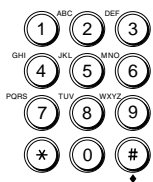

4. To change the sender name, use the buttons on the numeric keypad. (→3-7)

-or-

To delete the sender name, press CLEAR.



5. When you are finished making changes, press SET.



6. Press STOP to return to standby.

## Using the Energy Saver Mode

You can set the fax machine to enter a low-energy sleep mode after it remains idle for a specified length of time. This ensures that the fax machine consumes less power when it is not being used.

### Turning the Energy Save Feature ON



DATA REGISTRATION



1. Open both One-touch Speed Dialling panels. Then press DATA REGISTRATION.

REGISTRATION  
1.DATA REGISTRATION

2. Press SET.

DATA REGISTRATION  
1.USER SETTINGS



3. Press the search buttons until you see the display below.

DATA REGISTRATION  
7.SYSTEM SETTINGS



4. Press SET.

SYSTEM SETTINGS  
1.PASSWORD



5. Press the search buttons until you see the display below.

SYSTEM SETTINGS  
10.ENERGY SAVER



6. Press SET.

ENERGY SAVER  
OFF



7. Press a search button to display ON.

ENERGY SAVER  
ON



8. Press SET.

ENERGY SVR TIME  
03MIN.

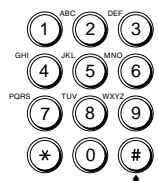

9. Use the buttons on the numeric keypad to enter a number for the time (minutes) you want the fax machine to remain idle before it automatically enters the low-energy sleep mode. You can set a time from 03 to 30 minutes.

ENERGY SVR TIME  
30MIN.



10. Press SET.

SYSTEM SETTINGS  
11.PHONE NO. CHECK



11. Press STOP to return to standby.

After the fax machine enters the energy saver mode, only the energy saver indicator on the operation panel remains on and the LCD display shows:

ENERGY SAVER

## Returning to the Full Power Mode

The display tells you the fax has entered the energy save mode with this message:

ENERGY SAVER

ENERGY SAVER



The indicator under the energy saver button to the right of the LCD display will also light red.

To restore the full power mode, press the ENERGY SAVER button. While the fax machine is powering up, PLEASE WAIT is displayed for a few moments.

PLEASE WAIT



---

While the fax unit is powering up, you can perform any operation.

---

The following actions will automatically restore the full power mode:

- Receiving a document.
- Printing an Activity Management report pre-set for printing.
- Answering a call.

You can awaken the fax from the low-energy sleep mode by:

- Pressing the ENERGY SAVER button.
- Setting a document on the fax for sending or copying.

The fax *does not* enter the energy save mode in the following cases:

- When documents are stored in the memory.
- When a paper or document jam has occurred, when the paper cassettes have run out of paper, or when the toner cartridge has run out of toner.
- When a document has been fed into the automatic document feeder (ADF).



---

You can not press the ENERGY SAVER button to put the fax in the energy save mode. The fax enters the energy save mode only after the specified time has elapsed.

---



# Chapter 4

## Setting Up and Using Speed Dialling

---

This chapter introduces some basic dialling features then shows you how to set up the speed dialling buttons.

Speed dialling includes One-touch Speed Dialling, Coded Speed Dialling, and Group Dialling. Directory dialling, also described in this chapter, allows you to locate a number for dialling by searching names and numbers registered on the fax for speed dialling.

After you set up your speed dialling buttons, we recommend that you occasionally print a list of all telephone numbers registered in the fax and store it for reference. (→14-2)

Read This before Entering Telephone Numbers .....	4-2
Entering Pauses for Dialling .....	4-2
Adjusting the Length of a Pause .....	4-3
Confirming a dial tone .....	4-4
What is Speed Dialling? .....	4-5
Setting Up One-touch Speed Dialling .....	4-6
Setting Up Coded Speed Dialling .....	4-14
Setting Up Group Dialling .....	4-22
Using Speed Dialling .....	4-26
Using One-touch Speed Dialling .....	4-26
Using Coded Speed Dialling .....	4-28
Using Group Dialling .....	4-29
Using Directory Dialling .....	4-31

# Read This before Entering Telephone Numbers

Read this section before you register numbers for speed dialling, especially if your site has special dialling requirements like dialling through a PBX.

When you have to make calls to an outside line or an extension, you may have to press R before you dial the outside line number or the extension number. Before you can use the R button, you have to register it. (→16-6)

## Entering Pauses for Dialling

If your fax is connected to a switchboard or PBX (private branch exchange), you may have to dial a number to connect to an outside line. The outside number must also be registered with the fax number. The switching system may also require that you insert a pause after the outside number. For further assistance, contact your local authorized Canon dealer sales or service representative or your local telephone company.

Follow this procedure to enter a pause during regular dialling or when registering a number for a speed dialling button.



1. When you come to a step that asks you to enter a number for dialling, use the buttons on the numeric keypad to enter the number.

```
TELEPHONE NUMBER  
TEL=03_
```



PAUSE



2. To enter a pause between two numbers, open both One-touch Speed Dialling panels and press PAUSE. After you enter the next number, the “P” changes to a small “p”.

```
TELEPHONE NUMBER  
TEL=03P_
```

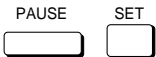

3. To enter a pause at the end of a number, press PAUSE then press SET. The pause at the end of a number appears as an upper case “P”.

```
TELEPHONE NUMBER  
TEL=03p123 4567P
```

Keep in mind these important points about pauses:

- A pause entered within a number (p) is 2 seconds long.
- You can add consecutive pauses (pp) with the PAUSE button. Each additional pause adds 2 seconds to the pause time.
- You can change the length of a pause entered within a number. (→below)
- A pause at the end of a number (P) is 10 seconds long.
- You may have to insert one or more pauses at the end of a number to dial an overseas number.

## Adjusting the Length of a Pause

Follow this procedure to adjust the length of a pause entered within a number.



---

This procedure is effective only for adjusting the length pauses entered within telephone numbers. The 10-second pause entered at the end of a number can not be adjusted.

---



1. Open the TX SETTINGS menu.

Open both One-touch Speed Dialling panels. Then press DATA REGISTRATION.

DATA REGISTRATION



REGISTRATION  
1.DATA REGISTRATION

SET



2. Press SET.

DATA REGISTRATION  
1.USER SETTINGS

^

v



Press the search buttons until you see the display below.

DATA REGISTRATION  
3.TX SETTINGS



3. Press SET.

TX SETTINGS  
1.ECM TX

Press the search buttons until you see the display below.



TX SETTINGS  
2.MID PAUSE SET



4. Press SET.

MID PAUSE SET  
02SEC

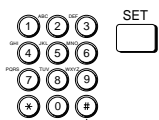

5. Use the buttons on the numeric keypad to enter a new time. You can enter a number from 01 to 15 seconds. Then press SET.



6. Press STOP to return to standby.

## Confirming a dial tone

Use this feature only when you register a number. In some areas you may have to confirm the dial tone in the middle of the facsimile number before dialling the rest of the number. This is called dial tone detection.

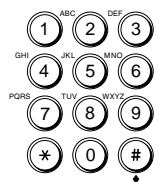

1. Use the numeric keys to enter the first part of the number until dial tone detection is required.

TELEPHONE NUMBER  
TEL=123\_



D.T.

2. Open both One-touch Speed Dialling panels and press D.T. for the dial tone. Where the dial tone is inserted, you will see a small dot. During dialling, this is where the fax waits for dial tone.

TELEPHONE NUMBER  
TEL=123·

3. Enter the remainder of the number

TELEPHONE NUMBER  
TEL=123·3456



## What is Speed Dialling?

Speed dialling allows you streamline and customize dialling procedures by registering a telephone number and other important settings so you can start a document transmission while pressing only a few buttons.

The three methods of speed dialling include:

### **One-touch Speed Dialling**

One-touch Speed Dialling allows you to start a document transmission by pressing only one button. You can register up to 72 destinations for One-touch Speed Dialling. The first group of buttons numbered 01 to 32 are on the operation panel. Open the first panel to see buttons 33 to 64, then the second panel to see the last set of buttons 65 to 72.

### **Coded Speed Dialling**

Coded Speed Dialling allows you to start a document transmission by pressing the CODED DIAL button followed by a three-digit code of your choice. While Coded Speed Dialling requires you to press more buttons, it allows you to register up to 128 numbers.

### **Group Dialling**

Group Dialling allows you to dial a group of registered One-touch or Coded Speed Dialling fax numbers. By registering each group for One-touch (or Coded Speed dialling) buttons, you press only one (or four buttons) to send the same document to several locations.

# Setting Up One-touch Speed Dialling

One-touch Speed Dialling allows you to dial a number and send a document at the press of one button. You can register up to 72 fax numbers, one for every One-touch Speed Dialling button on the operation panel. In addition to the telephone number and name of the other party, you can set the timer for the transmission as well as enter other important settings.

Follow this procedure to register a telephone number for One-touch Speed Dialling.



DATA REGISTRATION



1. Open the One-touch Speed Dialling menu.

Open both One-touch Speed Dialling panels. Then press DATA REGISTRATION.

REGISTRATION  
1.DATA REGISTRATION

Press the search buttons until you see the display below.

REGISTRATION  
2.TEL REGISTRATION

Press SET.

TEL REGISTRATION  
1.1-TOUCH SPD DIAL

Press SET.

1-TOUCH SPD DIAL  
01=

2. Specify the One-touch Speed Dialling button that you want to register.

Press the search buttons to scroll the display. Press the down search button to scroll to the next number or press the up search button to scroll to the previous number.

-or-

Close the appropriate One-touch Speed Dialling panel and press the One-touch Speed Dialling button that you want to register.



If a number is already registered for a button, you will see that number displayed.  
If a button is registered for Group Dialling, you will see GROUP DIAL.

1-TOUCH SPD DIAL  
10=



With the number of the button you want to register displayed on the LCD, press SET.

1-TOUCH SPD DIAL  
1.TELEPHONE NUMBER



3. Press SET.

TELEPHONE NUMBER  
TEL=\_

Enter the telephone number.



- Use the buttons on the numeric keypad to enter the fax number.
- To enter a space, press SPACE. Spaces are optional and they are ignored during dialling.
- After you have entered the number if you see that one of the digits is incorrect, press the left cursor key (<) to move the cursor to the digit you want to correct and press DELETE. Then enter the correct number.
- If you make a mistake, press CLEAR to erase the number and start again.

TELEPHONE NUMBER  
TEL=123 4567\_



4. Press SET.

TELEPHONE NUMBER  
DATA ENTRY OK

1-TOUCH SPD DIAL  
2.NAME



5. Enter a name.

Press SET.



Use the buttons on the numeric keypad to enter a name for the number up to 16 characters long. (→3-7)

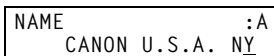
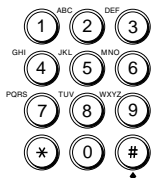

6. Press SET.



This completes the minimum settings for registering a One-touch Speed Dialling button.

**To stop here and register another button**

Press DATA REGISTRATION.

Repeat the procedure from step 2.

DATA REGISTRATION



**To end the procedure and return to standby**

Press STOP.



**To perform the optional settings**

7. Open the OPTIONAL SETTING menu.

Press SET.



Press the search buttons until you see the display below.







Press SET.

OPTIONAL SETTING  
1.SET TIME

8. Set the time for the transmission.

- If you set the timer for the One-touch Speed Dialling button, every document you send with this button will be sent at the same time every day.
- You can set up to 5 different times in a 24-hour period for sending.
- You can use this feature together with BATCH TX. If BATCH TX is ON, the documents will be grouped and sent together at the preset time. The fax unit will make only one phone call, saving you time and money. (→16-10)



Press SET.

SET TIME  
1: :



Press SET again.

SET TIME  
1: \_ :

Use the buttons on the numeric keypad to enter the time. Enter the time in the 24-hour format (e.g. 1:00 p.m. as 13:00).

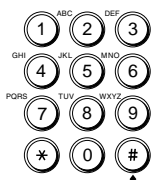

SET TIME  
1: 00:30



If you want to clear the time you have set, do the procedure from the beginning and press CLEAR at this step, then press SET.



Press SET.

SET TIME  
2: :



Press SET.

SET TIME  
2: \_ :



Enter another time and press SET. You can register up to 5 sending times.

-or-



To end registration and return to standby, press STOP.

-or-

DATA REGISTRATION



To continue registration for the current button, press DATA REGISTRATION.

OPTIONAL SETTING  
2.TX TYPE

9. Perform the transmission type settings.

Press SET. Then press the search buttons to display the transmission type items.



TX TYPE  
REGULAR TX

TX TYPE  
POLLING RX



For details about using ITU-T subaddresses and passwords, see the description of setting up and using a memory box. (→8-10)

**The TX TYPE menu includes these items:**

REGULAR TX

Designates the transaction as a normal transmission with no special features. *You can cancel the currently set TX TYPE by selecting REGULAR TX.*

CONFIDENTIAL TX	Designates the transaction as a transmission to a confidential mailbox. Press SET then enter the subaddress and password for the confidential mailbox. (→10-9)
1.PASSWORD	The ITU-T password for the other party's confidential mailbox.
2.SUBADDRESS	The ITU-T subaddress for the other party's confidential mailbox.
ORIG RELAY TX	Designates the transaction as a relay transmission with your fax as the originator. Press SET then enter the subaddress and password for the relay broadcast. (→9-2)
1.PASSWORD	The ITU-T password for the relay broadcast.
2.SUBADDRESS	The ITU-T subaddress for the relay broadcast.
PSWD/SUBADDRESS	Allows you to enter a ITU-T password or subaddress for the transmission. (→6-24)
1.PASSWORD	The ITU-T password for the transmission.
2.SUBADDRESS	The ITU-T subaddress for the transmission.
POLLING RX	Allows you to set a One-touch Speed Dialling button to poll another fax every time you use it to dial. Press SET then enter the ITU-T subaddress and password. (→11-3)
1.PASSWORD	The ITU-T password for the other party's polling box
2.SUBADDRESS	The ITU-T subaddress for the other party's polling box.

Display the TX TYPE you wish to register, then press SET. Next, set the ITU-T password and subaddress for the feature you selected.

You can cancel the currently set TX TYPE by selecting REGULAR TX.



Only one feature can be set for TX TYPE. The next time you open the TX TYPE menu to change the setting, you will see the currently set item displayed first.

OPTIONAL SETTING 3.LONG DISTANCE
-------------------------------------

10. If you experience transmission errors during long distance sending, change the long distance setting.

OPTIONAL SETTING  
3.LONG DISTANCE

SET

Press SET.

LONG DISTANCE  
DOMESTIC

^      v  
  

Press the search buttons until you see the display you want.

LONG DISTANCE  
LONG DISTANCE (1)

Select LONG DISTANCE (1) and try to send the document again. If this setting does not solve the problem, try settings (2) and (3).

SET

Press SET.

OPTIONAL SETTING  
4.TX SPEED

11. Change the transmission speed when it takes a long time for your document transmissions to begin.

SET

Press SET.

TX SPEED  
14400bps



---

If your document transmissions are slow in starting, this may mean that the telephone lines in your area are in poor condition. Select a lower speed. You can select 14400, 9600, or 4800 bps.

---

^      v  
     
SET

Press the search buttons to display the speed you want to select. Then press SET.

OPTIONAL SETTING  
5.ECM

12. Turn ECM off or on.



Press SET.

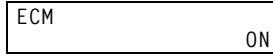

Press the search buttons to display OFF or ON.



---

ECM (error correction mode) reduces system and line errors during sending or receiving with another fax that supports ECM. Otherwise, this setting is ignored. If transmission speed appears to be extremely slow, you may be able to speed up transmission time by turning ECM off.

---



Press SET.

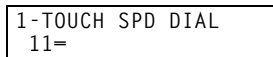

This completes all settings for telephone registration of a One-touch Speed Dialling button.

If you want to set up other buttons, repeat from step 2.

-or-

Press STOP to return to standby.



13. After you register a number for One-touch Speed Dialling, make sure you write the name of the other party on a destination label and stick it on the One-touch Speed Dialling panel above the number of the One-touch Speed Dialling button where the number is registered.

# Setting Up Coded Speed Dialling

Coded Speed Dialling allows you to dial a number and send a document by pressing four buttons. First you press CODED DIAL and then enter a three-digit code. You can register up to 128 fax numbers for this speed dialling method. In addition to the telephone number and name of the other party, you can set the timer for the transmission and as well as enter other important settings identical to those for Coded Speed Dialling.

Follow this procedure to register a telephone number for Coded Speed Dialling.

1. Open the Coded Speed Dialling menu.

Open both One-touch Speed Dialling panels. Then press DATA REGISTRATION.

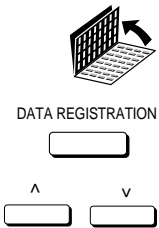

REGISTRATION  
1.DATA REGISTRATION

Press the search buttons until you see the display below.

REGISTRATION  
2.TEL REGISTRATION

Press SET.



TEL REGISTRATION  
1.1-TOUCH SPD DIAL

Press the search buttons until you see the display below.



TEL REGISTRATION  
2.CODED SPD DIAL

Press SET.



CODED SPD DIAL  
★000=



2. Specify the Coded Speed Dialling code that you want to register.

Press CODED DIAL. Then use the buttons on the numeric keypad to enter a three-digit code (000-127).

-or-

Press the search buttons to scroll the display. Press the down search button to scroll to the next number or press the up search button to scroll to the previous number.



If a telephone number is already registered for a three-digit code, you will see that number displayed. If a button is registered for Group Dialling, you will see GROUP DIAL displayed.

CODED SPD DIAL  
\*012=



With the code you want to register displayed on the LCD, press SET.

CODED SPD DIAL  
1. TELEPHONE NUMBER



Press SET again.

TELEPHONE NUMBER  
TEL=\_



3. Enter the telephone number.

- Use the buttons on the numeric keypad to enter the number.
- To enter a space, press SPACE. Spaces are optional and they are ignored during dialling.
- After you have entered the number if you see that one of the digits is incorrect, press the left cursor key (<) to move the cursor to the digit you want to correct and press DELETE. Then enter the correct number.
- If you make a mistake, press CLEAR to erase the number and start again.

TELEPHONE NUMBER  
TEL=123 4567\_



Press SET.

TELEPHONE NUMBER  
DATA ENTRY OK

CODED SPD DIAL  
2.NAME



4. Enter a name.

Press SET.

NAME \_\_\_\_\_ :A  
\_

Use the buttons on the numeric keypad to enter a name for the number up to 16 characters long. (→3-7)

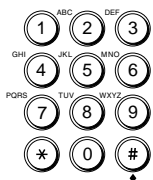

NAME \_\_\_\_\_ :A  
CANON CANADA



Press SET.

NAME \_\_\_\_\_ :A  
DATA ENTRY OK

CODED SPD DIAL  
3.OPTIONAL SETTING

This completes the minimum settings for registering a three-digit Coded Speed Dialling code.

**To stop here and register another code**

Press DATA REGISTRATION.

DATA REGISTRATION



Repeat the procedure from step 2.

**To end the procedure and return to standby**

Press STOP.



**To perform the optional setting**

5. Press SET to continue.



OPTIONAL SETTING  
OFF





Press the search buttons until you see the display below.

OPTIONAL SETTING  
ON



Press SET.

OPTIONAL SETTING  
1.SET TIME

6. Set the time for the transmission.

- If you set the timer for the Coded Speed Dialling code, every document you send with this code will be sent at the same time every day.
- You can set up to 5 different times in a 24-hour period for sending.
- You can use this feature together with BATCH TX. If BATCH TX is ON, the documents will be grouped and sent together at the preset time. The fax unit will make only one phone call, saving you time and money. (→16-10)



Press SET.

SET TIME  
1:                    :



Press SET again.

SET TIME  
1:                    \_ :



Use the buttons on the numeric keypad to enter the time. Enter the time in the 24-hour format (e.g. 1:00 p.m. as 13:00).

SET TIME  
1:                    00:30



---

If you want to clear the time you have set, do the procedure from the beginning and press CLEAR at this step, then press SET.

---



Press SET.

SET TIME  
2:                   :



Press SET.

SET TIME  
2:                   \_ :

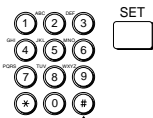

Enter another time and press SET. You can register up to 5 sending times.

-or-



To end registration and return to standby, press STOP.

-or-



To continue registration for the current button, press DATA REGISTRATION.

OPTIONAL SETTING  
2.TX TYPE

#### 7. Perform the transmission type settings.

Press SET. Then press the search buttons to display the transmission type items.

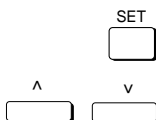

TX TYPE  
REGULAR TX

TX TYPE  
POLLING RX



For details about using ITU-T subaddresses and passwords, see the description of setting up and using a memory box. (→8-10)

#### The TX TYPE menu includes these items:

REGULAR TX	Designates the transaction as a normal transmission with no special features. <i>You can cancel the currently set TX TYPE by selecting REGULAR TX.</i>
------------	--

CONFIDENTIAL TX	Designates the transaction as a transmission to a confidential mailbox. Press SET then enter the subaddress and password for the confidential mailbox. (→10-9)
1.PASSWORD	The ITU-T password for the other party's confidential mailbox.
2.SUBADDRESS	The ITU-T subaddress for the other party's confidential mailbox.
ORIG RELAY TX	Designates the transaction as a relay transmission with your fax as the originator. Press SET then enter the subaddress and password for the relay broadcast. (→9-9)
1.PASSWORD	The ITU-T password for the relay broadcast.
2.SUBADDRESS	The ITU-T subaddress for the relay broadcast.
PSWD/SUBADDRESS	Allows you to enter a ITU-T password or subaddress for the transmission. (→6-25)
1.PASSWORD	The ITU-T password for the transmission.
2.SUBADDRESS	The ITU-T subaddress for the transmission.
POLLING RX	Allows you to set a Coded Speed Dialling button to poll another fax every time you use it to dial. Press SET then enter the ITU-T subaddress and password. (→11-3)
1.PASSWORD	The ITU-T password for the other party's polling box.
2.SUBADDRESS	The ITU-T subaddress for the other party's polling box.

Display the TX TYPE you wish to register then press SET. Next, set the ITU-T password and subaddress for the feature you just selected.

You can cancel the currently set TX TYPE by selecting REGULAR TX.



Only one feature can be set for TX TYPE. The next time you open the TX TYPE menu to change the setting you will see the currently set item displayed first.

OPTIONAL SETTING 3.LONG DISTANCE
-------------------------------------

8. If you experience transmission errors during long distance sending, change the long distance setting.

OPTIONAL SETTING  
3. LONG DISTANCE

SET

Press SET.

LONG DISTANCE  
DOMESTIC

^      v  
  

Press the search buttons until you see the display you want.

LONG DISTANCE  
LONG DISTANCE (1)

Select LONG DISTANCE (1) and try to send the document again. If this setting does not solve the problem, try settings (2) and (3).

SET

Press SET.

OPTIONAL SETTING  
4. TX SPEED

9. Change the transmission speed when it takes a long time for your document transmissions to begin.

SET

Press SET.

TX SPEED  
14400bps



---

If your document transmissions are slow in starting, this may mean that the telephone lines in your area are in poor condition. Select a lower speed. You can select 14400, 9600, or 4800 bps.

---

^      v  
  

Press the search buttons to display the speed you want to select. Then press SET.

SET

OPTIONAL SETTING  
5. ECM

10. Turn ECM off or on.



Press SET.



Press the search buttons to display OFF or ON.



---

ECM (error correction mode) reduces the effect of system and line errors on documents that occur during sending or receiving with another fax that supports ECM. Otherwise, this setting is ignored. If transmission speed appears to be extremely slow, you may be able to speed up transmission time by turning ECM off.

---



Press SET.

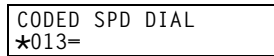

This completes all settings for telephone registration of Coded Speed Dialling codes.

If you want to set up other codes, repeat from step 2.

-or-

Press STOP to return to standby.



# Setting Up Group Dialling

Group Dialling allows you to register several telephone numbers for One-touch Speed Dialling or for Coded Speed Dialling so you can dial a large group of numbers by pressing a One-touch Speed Dialling button, or by pressing CODED DIAL, followed by a three-digit code. Telephone numbers already registered for One-touch or Coded Speed Dialling can be registered as members of the group.

Follow this procedure to register a group of telephone numbers for Group Dialling.



DATA REGISTRATION



1. Open the Group Dialling menu.

Open both One-touch Speed Dialling panels. Then press DATA REGISTRATION.

```
REGISTRATION
1.DATA REGISTRATION
```

Press the search buttons until you see the display below.



```
REGISTRATION
2.TEL REGISTRATION
```

Press SET.



```
TEL REGISTRATION
1.1-TOUCH SPD DIAL
```

Press the search buttons until you see the display below.



```
TEL REGISTRATION
3.GROUP DIAL
```

Press SET.



```
GROUP DIAL
01=
```

- Register the group of numbers for a One-touch Speed Dialling button or for a Coded Speed Dialling code.



**To register the group for a One-touch Speed Dialling button**

Press the search buttons to scroll the number display. Press the down search button to scroll to the next number or press the up search button to scroll to the previous number.

-or-

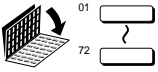

Close the appropriate One-touch Speed Dialling panel and press the One-touch Speed Dialling button you want to register.

If a number is already in use, you will see 1-TOUCH SPD DIAL, CODED SPD DIAL or GROUP DIAL displayed.

With an empty button number displayed, press SET.

**To register the group for Coded Speed Dialling**

Press CODED DIAL.



Use the buttons on the numeric keypad to enter the three-digit code you want to use for speed dialling (000-127).

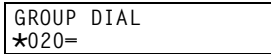
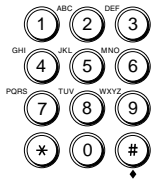

Press SET.



- Register all the numbers for the group.

Press SET.

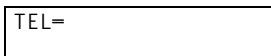

**To register a One-touch Speed Dialling button**

Close the appropriate One-touch Speed Dialling panel.

Press the One-touch Speed Dialling button with the telephone number you want to include in the group.

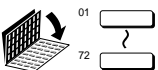



### To register a Coded Speed Dialling button

Press CODED DIAL then use the numeric keypad to enter the three-digit code where the telephone number you want to include in the group is registered.

You can enter up to 199 numbers.

When you are finished entering telephone numbers, press SET.



GROUP DIAL  
DATA ENTRY OK

GROUP DIAL  
2.NAME

#### 4. Enter a name for the group.

Press SET.



NAME :A

Use the buttons on the numeric keypad to enter a name for the number up to 16 characters long. (→3-7)



NAME :A  
CANON GROUP A

Press SET.



NAME :A  
DATA ENTRY OK

GROUP DIAL  
3.SET TIME

#### 5. Set the time for the group transmission.

- This setting is optional. If you do not set the timer, the transmission will begin after you press the One-touch Speed Dialling button, or press CODED DIAL followed by a three-digit code, for the group.
- If you set the timer for the Group Dialling code, every document you send with this code will be sent at the same time every day.



- You can set up to 5 different times in a 24-hour period for sending.
- You can use this feature together with BATCH TX. If BATCH TX is ON, the documents will be grouped and sent together at the preset time. The fax unit will make only one phone call, saving you time and money. (→16-10)



Press SET.

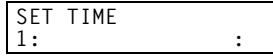

Press SET again then use the buttons on the numeric keypad to enter the time. Enter the time in the 24-hour format (e.g. 1:00 p.m. as 13:00).

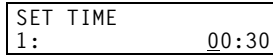
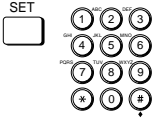

Press SET.

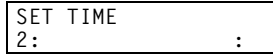

6. Press SET, enter another time, and press SET. You can register up to 5 sending times.

-or-

To continue registering another group, press DATA REGISTRATION.

-or-

To end registration and return to standby, press STOP.

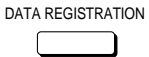

# Using Speed Dialling

Follow the procedures in this section to use speed dialling. The three speed dialling methods are One-touch Speed Dialling, Coded Speed Dialling, and Group Dialling. If you forget where a number is registered, you can find it and dial it with directory dialling. (→4-31)

## Using One-touch Speed Dialling

Follow this procedure to start a transmission and send a document at the press of a One-touch Speed Dialling button.



---

To use this feature, you must first register a telephone number for One-touch Speed Dialling. (→4-6)

---

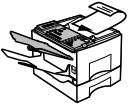

1. Set the document on the fax. (→6-3)

Set the document resolution, contrast, and document type. (→6-4)

You can also select a sender's name with the TTI SELECTOR. (→6-6)

DOCUMENT READY
----------------

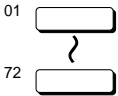

2. Press the One-touch Speed Dialling button where the telephone number you want to dial is registered.

If you do not see the number of the button you want, open the first or second One-touch Speed Dialling panel to see more buttons. After 5 seconds, the fax starts to send the document.

TEL=	123 4567
01	CANON USA

TRANSMIT	0025
SCANNING DOC.	P.001

You will see a series of brief, alternating messages that tell you the fax is dialling, calling, then transmitting the document. The number being dialled, name of the other party, and the transaction number of the document are also displayed.

Here are some important points you should keep in mind when you use One-touch Speed Dialling:

- To start scanning immediately, press START/SCAN. Otherwise the fax will wait 5 seconds before it starts scanning. This timeout feature can be turned off. (→16-11)
- To locate and press the correct button, you may have to open the One-touch Speed Dialling panels.
- The fax will not dial the number registered for the One-touch Speed Dialling button until you set the document on the fax for sending. If you press the button before you load the document, the fax will prompt you:

SET DOCUMENT

- If you press a One-touch Speed Dialling button where no number has been registered, the fax tells you:

NO TEL#  
12

- If you want to cancel the transmission after you press a One-touch Speed Dialling button, press STOP. (→6-8)
- When you come to a step in any procedure where you have to dial a number, you can press a One-touch Speed Dialling button to dial.



---

When you register a number for One-touch Speed Dialling, Coded Speed Dialling and Group Dialling, you can, as an option, set the time you want your document to go out (up to 5 different times in a day). If you are using a speed dial button that was set by someone else, and you would like your document to go out at the preset time, verify if the preset time feature is being used for that button. (→4-9, 4-17, 4-24, 16-30)

---

## Using Coded Speed Dialling

Follow this procedure to start a transmission and send a document at the press of the CODED DIAL button followed by a three-digit code.



---

To use this feature, you must first register a telephone number for Coded Speed Dialling. (→4-14)

---

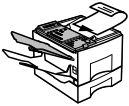

1. Set the document on the fax. (→6-3)

Set the document resolution, contrast, and document type. (→6-4)

You can also select a sender's name with the TTI SELECTOR. (→6-6)

DOCUMENT READY



2. Press CODED DIAL once.

TEL=  
★

3. Use the buttons on the numeric keypad to enter the three-digit code of the telephone number you want to dial (000-127).

After 5 seconds, the fax starts to send the document.

TEL= 123 4567  
★001 CANON ONTARIO

TRANSMIT 0026  
SCANNING DOC. P.001

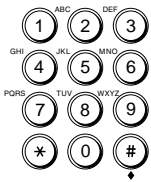

You will see a series of brief, alternating messages that tell you the fax is dialling, calling, then transmitting the document. The number being dialled, name of the other party, and the transaction number of the document are also displayed.

Here are some points you should keep in mind when you use Coded Speed Dialling:

- To start scanning immediately, press START/SCAN. Otherwise the fax will wait 5 seconds before it starts scanning. This timeout feature can be turned off. (→16-11)
- The fax will not dial the Coded Speed Dialling number until you set the document on the fax for scanning. If you press the buttons before you load the document, the fax will prompt you:

SET DOCUMENT

- If you press CODED DIAL and a three-digit code where no numbers are registered, the fax tells you:

NO TEL#  
★013

- If you want to cancel the transmission after you press the buttons for Coded Speed Dialling, press STOP.
- When you come to a step in any procedure where you have to dial a number, you can press the buttons for Coded Speed Dialling to dial.



---

When you register a number for One-touch Speed Dialling, Coded Speed Dialling and Group Dialling, you can, as an option, set the time you want your document to go out (up to 5 different times in a day). If you are using a speed dial button that was set by someone else, and you would like your document to go out at the preset time, verify if the preset time feature is being used for that button. (→4-9, 4-17, 4-24, 16-27)

---

## Using Group Dialling

Follow this procedure to start a transmission and send a document to several destinations with a One-touch or Coded Speed dialling number registered for group dialling.



---

To use this feature, you must first register a group of telephone numbers for One-touch or Coded Speed Dialling. (→4-22)

---

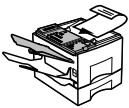

1. Set the document on the fax. (→6-3)

Set the document resolution, contrast, and document type. (→6-4)

You can also select a sender's name with the TTI SELECTOR. (→6-6)

DOCUMENT READY

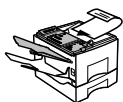

or



2. Press the One-touch Speed Dialling button, or press CODED DIAL followed by the three-digit code, where the group of telephone numbers you want to dial is registered.

The fax starts to send the document

```
TEL=GROUP DIAL
01 CANON USA
```

```
TRANSMIT          0025
SCANNING DOC.    P.001
```

You will see a series of brief, alternating messages that tell you the fax is dialling, calling, then transmitting the document. The number being dialled, name of the other party, and the transaction number of the document are also displayed.

Here are some points you should keep in mind when you use Group Dialling:

- To start scanning immediately, press START/SCAN. Otherwise the fax will wait 5 seconds before it starts scanning. This timeout feature can be turned off. (→16-11)
- The fax will not dial the numbers for the Group Dialling number until you set the document on the fax. If you press the One-touch Speed Dialling button or press CODED DIAL followed by a three-digit code, before you load the document, the fax will prompt you:

```
SET DOCUMENT
```

- If you press a One-touch Speed Dialling button, or press CODED DIAL followed by a three-digit code, where no number has been registered, the fax will display:

```
NO TEL#
12
```

If you want to cancel the transmission after you press a One-touch or Coded Speed Dialling button, press STOP.





---

When you register a number for One-touch Speed Dialling, Coded Speed Dialling and Group Dialling, you can, as an option, set the time you want your document to go out (up to 5 different times in a day). If you are using a speed dial button that was set by someone else, and you would like your document to go out at the preset time, verify if the preset time feature is being used for that button. (→4-9, 4-17, 4-24, 16-27)

---

## Using Directory Dialling

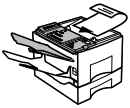
Follow this procedure to look up the other party's name and retrieve the number for dialling. This feature is convenient when you know the other party's name but can not recall the One-touch Speed Dialling button, the code for Coded Speed Dialling, or Group Dialling where the number is registered.



1. Set the document on the fax. (→6-3)

Set the document resolution, contrast, and document type. (→6-4)

You can also select a sender's name with the TTI SELECTOR. (→6-6)

2. Press DIRECTORY.



DIRECTORY DIAL 1ST LETT OF NAME :A
---------------------------------------

3. Press a numeric keypad button to enter the first letter of the name of the party you are searching for.

For example, if you press PQRS the first name and number registered for this button letter group is displayed.



TEL= 123 4567 10 PACIFIC BEACH
-----------------------------------

4. Press the directory search buttons on the front of the operation panel to display the other names and numbers registered for the button letter group.



TEL= 123 4567 12 SOUTHWEST
-------------------------------

- The names for One-touch Speed Dial are prefixed with two digits and the names for Coded Speed Dial numbers are prefixed with an asterisk (\*) and three digits.
- When you reach the last number and name registered for the letter group, you will return to the first number and name in the group.
- To see numbers and names registered for other letter groups, ABC for example, you will have to press the ABC button on the numeric keypad.
- After you press a button, if you see NO TEL# in the display, this means there are no names that begin with a letter of the button you just pressed.
- After you press the directory search keys, if the display does not change this means only one name and number is registered for the button you just pressed.

5. With the telephone number you want to dial displayed, press START/SCAN to start the document transmission.

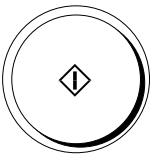

TRANSMIT	0031
SCANNING DOC.	P.001



# Chapter 5

## Using the Fax as a Copier

---

This chapter describes all the settings and procedures for using the fax unit as a copier.

Preparing the Document .....	5-2
Setting the Document on the Fax .....	5-3
Performing the Document Settings .....	5-4
Making Copies .....	5-5

# Preparing the Document

Follow these simple guidelines to check your document before you set the document on the fax for copying.

- For best results, load only documents of recommended standard size and weight. (→B-1)
- The document guides on the automatic document feeder (ADF) can be adjusted to the width of non-standard size paper. For best results, however, all sheets in the stack should be of the same width.
- To avoid document jams, never feed thick documents or documents backed with carbon paper.
- To avoid document jams and possible damage to the fax, avoid wrinkled or creased paper, carbon paper, curled paper, coated paper, and onion skin or other very thin paper.
- The fax does not scan completely to the edges of the paper and anything beyond this recommended margin will not be scanned for copying. See Appendix B and check your document. (→B-2)
- To avoid paper jams or damaging the fax, inspect the document carefully and make sure it is free of pins, staples, paper clips, and other metal fasteners.
- Make sure all the documents are dry. They should not have wet ink, glue, or paste on their surfaces.
- Before you feed a stack of documents into the fax, make sure all the pages are the same size and thickness. Do not attempt to feed documents of different size and thickness in the same stack.

# Setting the Document on the Fax

You can set a stack of up to 50 letter or A4 size pages or 20 legal size pages into the fax for copying.

1. Place the document *face down* on the automatic document feeder (ADF) of the fax unit.
2. If the document is too long for the automatic document feeder (ADF) (e.g. legal size), open the document extension tray.

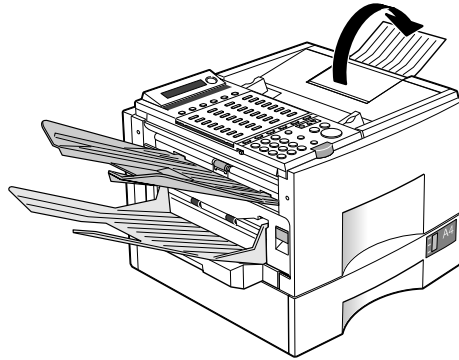

3. Slide the document guides to fit the width of the document.

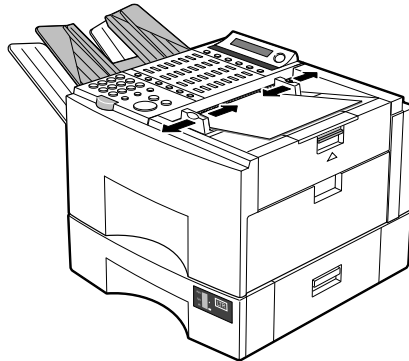

4. Make sure the document is below the load limit marks for A4 size.

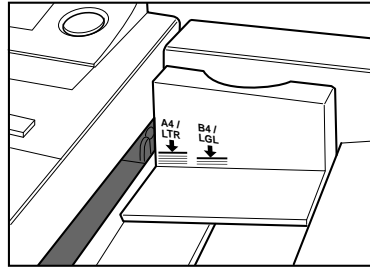

5. Insert the document into the fax until you hear the fax beep.  
The fax will display some messages.

MEMORY IN USE 36%

DOCUMENT READY

## Performing the Document Settings

Canon's original Ultra High Quality (UHQ) imaging technology allows you to make copies that are very close to the quality of the original document. For best results, adjust the settings for special documents before copying.

Follow these guidelines to change a setting:

- The lighted indicator tells you the current setting.
- Press the appropriate button repeatedly to light the setting you want.
- After the document is copied, the settings return to the setting before copying.

● SUPER FINE  
☀ FINE  
● STANDARD  
  
RESOLUTION

● DARKER  
☀ STANDARD  
● LIGHTER  
  
CONTRAST

☀ TEXT  
● TEXT/PHOTO  
  
DOCUMENT TYPE

RESOLUTION	When copying a document, FINE is automatically selected for you. (Although the resolution is actually fixed at Ultra-Fine)	
CONTRAST	Adjusts the lightness/darkness of the document pages scanned for copying.	
	DARKER	For documents with light text or colours.
	STANDARD	For standard printed or typewritten text.
	LIGHTER	For documents with dark text or colours.
DOCUMENT TYPE	Select for documents with text only or with text and photos on the same page.	
	TEXT/PHOTO	For documents that contain text and photographs on the same page. Automatically adjusts the quality of the image and text on the same page.
	TEXT	For documents that contain text without photographs.

## Making Copies

Follow this procedure to use the fax as a copier.

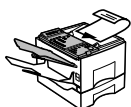

1. Set the document on the fax. (→5-3)



2. Press COPY.

COPY	01
FRONT CASSETTE	A4

### With option cassette

COPY	01
FRONT UPPER CAS.	A4



- If you want to select another paper cassette, open both One-touch Speed Dialling panels, then press the search buttons.



COPY	01
SIDE CASSETTE	LGL

- Use the buttons on the numeric keypad to enter the number of copies (01 to 99).



COPY	03
SIDE CASSETTE	LGL

- If you make a mistake and want to start again, press CLEAR.

- Press START/SCAN to start copying.

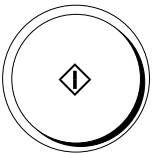

COPY
------

- If you want to cancel the operation, press STOP.



---

If you select more than one copy at step 3, the unit automatically switches to the memory copy mode. In the memory copy mode, there may be a slight deterioration in the quality of the copy. For best results, use the direct copy mode by printing only one copy per page (01).

---

# Chapter 6

## Sending Documents

---

This chapter describes fundamental procedures for dialling and sending documents.

We will also show you how to send a document to more than one location, set a document for delayed sending, and send a document with a subaddress and password.

Setting a Document for Sending .....	6-2
Preparing the Document .....	6-2
Setting the Document on the Fax .....	6-3
Adjusting the Scanning Settings .....	6-4
Selecting a Sender Name .....	6-6
Using Regular Dialling .....	6-7
Cancelling Sending a Document .....	6-8
Dialling Long Distance with Regular Dialling .....	6-9
Overview of Sending Methods .....	6-11
Memory Sending .....	6-11
Direct Sending .....	6-13
Manual Sending .....	6-15
Re-dialling When the Line is Busy .....	6-16
What is Automatic Redialling? .....	6-16
Setting Up Redialling .....	6-18
Sequential Broadcasting to More Than One Location .....	6-20
Sending Documents at a Preset Time .....	6-21
Sending a Document with a Subaddress/Password .....	6-24
Subaddress/Password Sending with Speed Dialling .....	6-24
Subaddress/Password Sending with the Operation Panel Buttons .....	6-25

# Setting a Document for Sending

This section describes how to prepare a document for sending and how to perform the initial settings before dialling.

## Preparing the Document

Follow these simple guidelines to check your document before you set the document on the fax for scanning.

- For best results, load only documents of recommended standard size and weight. (→B-1)
- The document guides on the automatic document feeder (ADF) can be adjusted to the width of non-standard size paper. For best results, all sheets in the stack should be of the same width.
- To avoid document jams, never feed thick documents or documents backed with carbon paper.
- For documents that are larger or smaller than these recommended limits, reduce them or enlarge them on a copy machine and then send the copy. (→B-2)
- To avoid document jams and possible damage to the fax, avoid wrinkled or creased paper, carbon paper, curled paper, coated paper, and onion skin or other very thin paper.
- The fax does not scan completely to the edges of the paper and anything beyond this recommended margin will not be scanned for sending. For details, refer to Appendix B. (→B-2)
- To avoid paper jams or damaging the fax, inspect the document carefully and make sure it is free of pins, staples, paper clips, and other metal fasteners.
- Make sure all the documents are dry. They should not have wet ink, glue, or paste on their surfaces.
- Before you feed a stack of documents into the fax, make sure all the pages are the same size and thickness. Do not attempt to feed documents of different size and thickness.



## Setting the Document on the Fax

You can set a stack of up to 50 letter or A4 size pages or 20 legal size pages into the fax for sending.

1. Place the document *face down* on the automatic document feeder (ADF) of the fax.
2. If the document is too long for the automatic document feeder (ADF) (e.g. legal size), open the document extension tray.

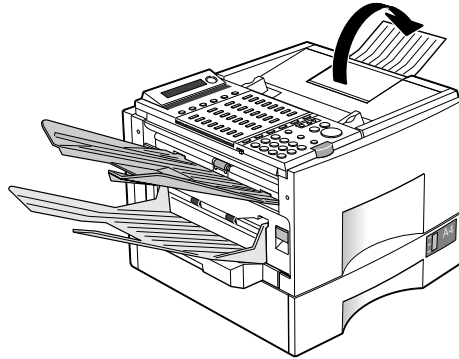

3. Slide the document guides to fit the width of the document.

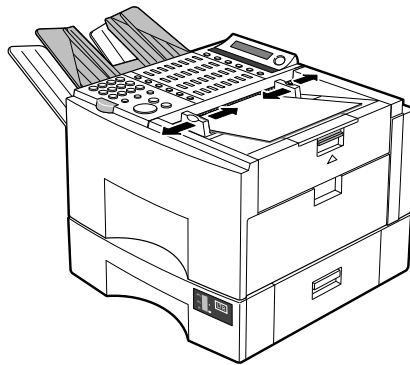

4. Make sure the document is below the load limit marks for A4 size.

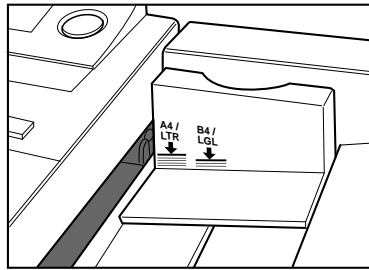

5. Insert the document into the fax until you hear the fax beep. The fax will display some messages.

MEMORY IN USE 36%

DOCUMENT READY

## Adjusting the Scanning Settings

Canon's original Ultra High Quality (UHQ) imaging technology allows you to send documents that are very close to the quality of the original document. For best results, adjust the settings for special documents before sending.

Follow these guidelines to change a setting:

- The lighted indicator tells you the current setting.
- Press the appropriate button repeatedly to light the setting you want.
- For documents that require special settings, you can set the PROGRAM button to perform the settings with a single button press. (→12-4)

● SUPER FINE  
 ☀ FINE  
 ● STANDARD

RESOLUTION

● DARKER  
 ☀ STANDARD  
 ● LIGHTER

CONTRAST

☀ TEXT  
 ● TEXT/PHOTO

DOCUMENT TYPE

RESOLUTION	Adjusts the resolution for documents with fine text and thin lines. The higher the resolution, the higher the quality output, but the slower the scanning speed.	
	STANDARD	For normal printed or typewritten text.
	FINE	Twice the STANDARD resolution.
	SUPER FINE	Four times the STANDARD resolution.
CONTRAST	Adjusts the lightness/darkness of the document pages scanned for sending.	
	DARKER	For documents with light text or colours.
	STANDARD	For standard printed or typewritten text.
	LIGHTER	For documents with dark text or colours.
DOCUMENT TYPE	Select for documents with text only or with text and photos on the same page.	
	TEXT/PHOTO	For documents that contain text and photographs on the same page. Automatically adjusts the quality of the image and text on the same page. After you select TEXT/PHOTO, FINE is automatically selected for RESOLUTION.
	TEXT	For documents that contain text without photographs.

If you frequently need to send and receive documents that require accurate reproduction of fine detail, you may want to change the default value for the SUPER FINE setting. You can alternate the value for SUPER FINE between two settings: Super Fine and Ultra Fine. The ULTRA FINE setting (16 dots/mm) is eight times the STANDARD RESOLUTION and twice the SUPER FINE, but you can switch to ultra fine by changing the 7. SCAN RESOLUTION setting of the USER SETTINGS menu. (→16-5)



If the other party does not have the ultra fine feature and you send a document with TEXT/PHOTO set for the document type setting and ULTRA FINE set for the resolution setting, the image the other party receives will reproduce at the other party's maximum resolution setting.

If you switch this setting to ULTRA FINE then every time you press the SUPER FINE button, the fax will be enabled for scanning with the ULTRA FINE setting.

# Selecting a Sender Name

Follow this procedure to select one of the registered sender names.

- Sender names are selected by pressing the TTI SELECTOR button.
- This setting is optional. If you do not select a sender name before sending a document, the registered unit name will be printed at the top of the document in the sender information area. (→3-12)
- If you select a sender name before you send a document, it will replace the unit name printed in the sender information area. (→3-12)
- Up to 99 sender names can be registered. At least one sender name must be registered so you can use this feature. (→3-17)

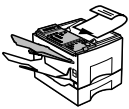

1. Set the document on the fax and adjust the document guides to the width of the document. (→6-3)

2. Dial the number.

Press the buttons on the numeric keypad to dial the number.

-or-

Press a One-touch Speed Dialling button to dial the number. (→4-26)

-or-

Press CODED DIAL and a three-digit code to dial the number. (→4-28)

-or-

Use directory dialling. (→4-31)

3. Press TTI SELECTOR until the desired name appears in the display.

-or-

Press TTI SELECTOR. Then press the search button until the desired name appears in the display.

4. Press SET.

5. Continue the procedure for the feature you want to use.

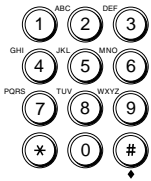

TTI SELECTOR



SET



# Using Regular Dialling

When you come to a step that requires dialling a number, you can dial the number with the buttons on the numeric keypad just like dialling a telephone number. This is called *regular dialling*.



---

To make dialling easier, register frequently used numbers for speed dialling. (→4-1)

---

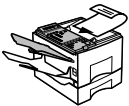

1. Set the document on the fax.

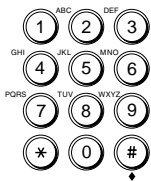

2. Dial the telephone number.

Use the buttons on the numeric keypad to dial the telephone number.

Just after you press a button if you see that you have entered the wrong number, just press DELETE to delete the rightmost digit. Then enter the correct number.

3. Press START/SCAN.

The fax starts scanning the first page into the memory.

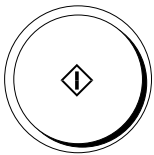

# Canceling Sending a Document

Follow this procedure to cancel a transmission in progress.



1. Press STOP.

If you are using direct sending, an alarm sounds and the transmission is cancelled immediately.

-or-

If you are using memory sending, a message is displayed.

CANCEL DURING TX/RX? YES=(*) NO=(#)
--

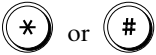

2. Press \* to cancel the transmission or press # if you change your mind and do not want to cancel.

After you press \* to cancel the transmission, an alarm sounds and a report prints unless this feature has been turned off. (→16-7)

PRINTING REPORT
-----------------

# Dialling Long Distance with Regular Dialling

Follow this procedure to dial a long distance number and send a document with regular dialling.

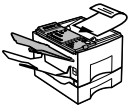

1. Set the document on the fax. (→6-3)  
Set the document resolution, contrast, and document type. (→6-4)



---

You can not select a sender's name after you press HOOK or pick up the handset.

---



2. Press HOOK. After you press HOOK the IN USE lamp lights and you will be able to hear the dial tone.

TEL=

-or-

If you know the other party's fax is set to automatic receiving, go to the next step.

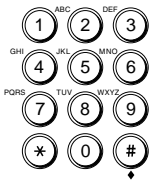

3. Use the buttons on the numeric keypad to dial the long distance number.



---

If you didn't press HOOK in step 2, you may have to insert a pause into a number for long distance dialling. (→4-2) For details about the location and length of the pause, contact your local telephone company or local authorized Canon dealer.

---

TEL= 011p81



4. Dial the remainder of the number then press START/SCAN. After a few moments the call will connect.

TEL=011p81 123 4567P

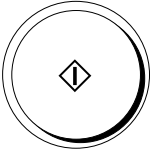

---

If you did not press HOOK in step 2, you may have to insert a pause at the end of the telephone number. The pause at the end of the number is 10 seconds. For details about the necessary length of the pause, contact your local telephone company or local authorized Canon dealer.

---

If you have installed the optional handset, when the other party answers, you can pick up the handset and talk.

Tell the other party to press the start button on their fax then hang up their handset. When you hear a high pitched tone, the other fax is ready to receive.

-or-

If you hear a high pitched tone as soon as the call connects, the other party is ready to receive.

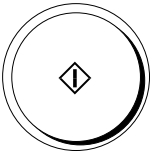

5. Press START/SCAN on your fax and hang up your handset.

The fax starts to send the document.



If the offhook alarm starts beeping, make sure the handset is sitting correctly on the handset cradle. The volume of the offhook alarm can be adjusted. (→16-6)



---

To take advantage of the speed dialling features, register frequently dialled long distance numbers for One-touch or Coded Speed Dialling buttons. (→4-6, 4-14)

---



# Overview of Sending Methods

This section briefly describes the methods and advantages of the three main sending methods: memory sending, direct sending, and manual sending.

## Memory Sending

With memory sending, document scanning and sending is fast, allowing you to get your document back quickly so you do not have to spend so much time standing around the fax. You can start scanning a document for sending even while the fax is busy sending another document.

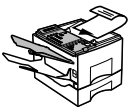
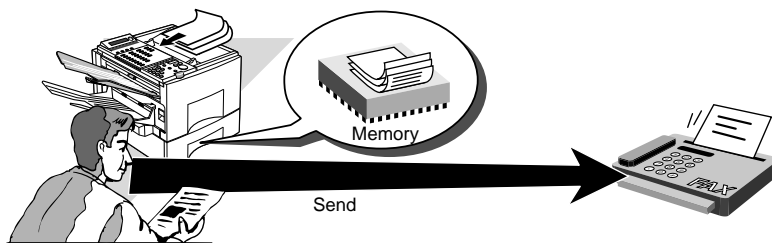

1. Set the document on the fax. (→6-3)

Set the document resolution, contrast, and document type. (→6-4)

You can also select a sender's name with the TTI SELECTOR. (→6-6)

2. Dial the other party's fax number.

Use the buttons on the numeric keypad to dial the number. (→6-7)

-or-

Press a One-touch Speed Dialling button to dial the number. (→4-26)

-or-

Press CODED DIAL and a three-digit code to dial the number. (→4-28)

-or-

Press DIRECTORY and search for the name to dial the number. (→4-31)

If you make a mistake during dialling, press STOP to return to standby and start again.

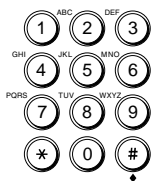



---

If you use One-touch or Coded Speed Dialling with the time out feature on, the fax will pause 5 seconds before it starts scanning the document. (→16-11)

---

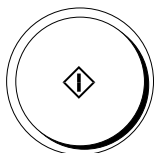

3. To start scanning right away, press START/SCAN.

If you use One-touch or Coded Speed Dialling, wait for the fax to start scanning automatically.

The timeout feature can be turned off. (→16-11)

You can start sending a document while it is being scanned into the memory. When scanning a multi-page document if the telephone line is free, the unit will call the other party after the first page is scanned. Once the connection is made, the fax unit will begin to transmit the information while the remaining pages are being scanned. This feature is called Quick-on-line TX and can be turned off and on. (→16-10)

When the fax sends a document, messages report the following information about the transmission.

#### Transaction number

TRANSMIT	0031	Transaction Number
SCANNING DOC.	P.001	

A transaction number is assigned to every document sent from your fax starting with 0001 up to 4999. When the number 4999 is reached, numbering will begin again from 0001.

#### Other party's fax number and name

26/12 '97 FRI 23:01 DIALLING
---------------------------------

26/12 '97 FRI 23:01 123 4567
---------------------------------

26/12 '97 FRI 23:01 CALLING 123 4567
---

26/12 '97 FRI 23:01 TX/RX NO. 0031
---------------------------------------

26/12 '97 FRI 23:01 CANON CANADA
-------------------------------------

Displayed only if the other party's telephone number and name are registered for the speed dialling button used to dial the number.

### ECM transmission mode

26/12 '97 FRI 23:05 ECM TX
-------------------------------

Unless this feature has been turned off, the document is sent in the ECM (error correction mode) for transmission. (→16-9)

### Successful completion

26/12 '97 FRI 23:05 TRANSMITTING OK
--

26/12 '97 FRI 23:05 TX/RX NO. 0031
---------------------------------------

Alternating messages tell you the transmission was successful. The message will disappear after approximately 10 seconds.

### Transmission error

If a transmission error occurs, read the error message in the display and look it up in the error message table. (→15-24)

## Direct Sending

The fax dials the number, connects the call, and then scans and sends the document one page at a time. Direct sending is slower than memory sending, but because this method bypasses memory you can send a document ahead of other documents stored in the memory.



- Direct sending scans and sends each page one at a time.
- With direct sending you can watch each page as it is scanned and sent.

- Although direct sending is slower than memory sending, you can use direct sending when you need to send an urgent document ahead of other documents stored in the memory.
- You can also use direct sending when the memory is full and there is no space to hold another document in memory.

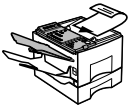

1. Set the document on the fax. (→6-3)  
Set the document resolution, contrast, and document type. (→6-4)  
You can also select a sender's name with the TTI SELECTOR. (→6-6)
2. Press DIRECT TX.  
The DIRECT TX lamp lights. The fax is now in the direct sending mode.



3. Dial the other party's fax number.  
Use the buttons on the numeric keypad to dial the number. (→6-7)  
-or-  
Press a One-touch Speed Dialling button to dial the number. (→4-26)  
-or-  
Press CODED DIAL and a three-digit code to dial the number. (→4-28)  
-or-  
Press DIRECTORY and search for the name to dial the number. (→4-31)  
If you make a mistake during dialling, press STOP to return to standby and start again.

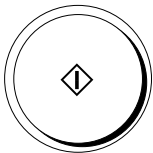

4. Press START/SCAN.  
The fax dials the other party's number and sends the fax. Each page is sent as it is scanned.  
A series of messages report the other party's name, telephone number, and transaction number in the LCD display. The final message reports successful transmission.

26/12 '97 FRI 12:05  
TRANSMITTING OK



5. Press DIRECT TX to turn off the direct sending mode.

# Manual Sending

Manual sending allows you to talk to the other party before you send the document. This method is useful if the operator of the other fax must manually set the other fax to receive before it can receive a document.



---

The handset is available as an option. (→2-9)

---

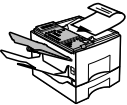
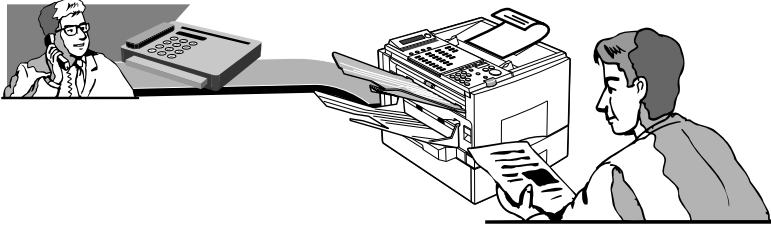

1. Set the document on the fax. (→6-3)

Set the document resolution, contrast, and document type. (→6-4)



---

You can not set sender's name when sending manually.

---



2. Press HOOK.

After you press HOOK the IN USE lamp lights and you will be able to hear the dial tone.

-or-

Without pressing HOOK, just pick up the handset if you have installed the optional handset.

3. Dial the other party's fax number.

Use the buttons on the numeric keypad to dial the number. (→6-7)

-or-

Press a One-touch Speed Dialling button to dial the number. (→4-26)

-or-

Press CODED DIAL and a three-digit code to dial the number. (→4-28)

-or-

Press DIRECTORY and search for the name to dial the number and then press START/SCAN. (→4-31)



If you make a mistake during dialling, press STOP to return to standby and start again.

4. When you hear the other party answer the call, you can talk.

When you hear the other party answer, pick up the handset so you can talk if you have not already done so. Then go to step 5.

-or-

If you hear a high pitched signal, instead of the other party's voice, they are ready to receive your document. Go to step 7.

5. Ask the other party to press the start button on their fax and then hang up their handset.
6. After the other party presses the start button on their fax, you will hear a high pitched signal.
7. Press START/SCAN on your fax and hang up your handset.

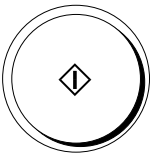

The fax begins to send the document. If the offhook alarm starts beeping, make sure the handset is resting properly on the handset cradle.

## ***Re-dialling When the Line is Busy***

If the other party's line is busy or if there is no answer, the fax waits two minutes and then dials the same number again. This feature is called *automatic redialling*.

### ***What is Automatic Redialling?***

After the initial dial attempt, the fax will wait two minutes and try to dial again. If the second attempt fails, the fax will again wait for two minutes and make a final attempt to complete the call.

Auto redial can be turned off and on. The number of redialling attempts and the time interval between attempts can be set up with the auto redial feature. (→6-10)

While the fax is waiting to redial, the following messages are displayed alternately:

26/12 '97 FRI 09:30 AUTO REDIAL
------------------------------------

26/12 '97 FRI 09:30 TX/RX NO. 3888
---------------------------------------

If both redial attempts are unsuccessful the fax will cancel the transaction, display the following message, and print an Activity Report to remind you that the transmission was not completed.

26/12 '97 FRI 09:30 BUSY/NO SIGNAL
---------------------------------------

**To cancel redialling**

If you are using direct sending, press STOP.



-or-

DELETE FILE



If you are using memory sending, press DELETE FILE.

**To resend the document in the memory**

Use the MEMORY REFERENCE button to resend the document. (→8-6)

MEMORY REFERENCE



**To erase the document from the memory**

Use the DELETE FILE button to delete the file from the memory. (→8-9)

DELETE FILE



## Setting Up Redialling

Follow this procedure to set up these redialling features:

- The number of times the fax attempts to redial.
- The length of the time interval the fax waits between dialling attempts.
- Re-sending method after an error occurs.

1. Open the TX SETTINGS menu.

Open both One-touch Speed Dialling panels. Then press DATA REGISTRATION.



DATA REGISTRATION



SET



REGISTRATION  
1.DATA REGISTRATION

Press SET.

DATA REGISTRATION  
1.USER SETTINGS

Press the search buttons until you see the display below.



DATA REGISTRATION  
3.TX SETTINGS

SET



Press SET.

TX SETTINGS  
1.ECM TX

2. Press the search buttons until you see the display below.



TX SETTINGS  
3.AUTO REDIAL

SET



Press SET.

AUTO REDIAL  
ON



If OFF is displayed, press the search buttons until you see ON.

Press SET.



3. Press the search buttons to display the item you want to set up, then Press SET.



4. Press STOP to return to standby.

## Auto Redial Setup Summary

The default settings, shown in bold, remain in effect unless you change them.

1. REDIAL TIMES	Sets the number of times the fax attempts to dial a number before it cancels the transaction automatically.
	<b>02TIMES</b> You can set between 01 to 10 dialling attempts.
2. REDIAL INTERVAL	Sets the length of time the fax waits between dialling attempts.
	<b>02MIN.</b> You can set the time interval between 02 to 99 minutes.
3. TX ERROR RESEND	<b>ON</b> Determines how the fax handles re-sending if an error occurs.
	RESEND TX FROM Tells the fax how to handle re-sending after an error occurs.
	<b>ERROR &amp; 1ST PG</b> Re-sends from the page where the error occurred. It also re-sends the first page of the document.
	ERROR PAGE Re-sends from the page where the error occurred.
	ALL PAGES Re-sends all pages of the document.
	OFF Turns off the “re-sending after an error occurs” feature.

# Sequential Broadcasting to More Than One Location

Follow this procedure to scan a document once and send it to several locations. With this sending method, called *sequential broadcasting*, you can send the same document to a maximum of 210 locations.



If you frequently send the same document to several locations, use Group Dialling. With Group Dialling you can register up to 199 facsimile numbers and send the same document to these numbers at the press of only one or four buttons. (→4-22)

If you use sequential broadcasting frequently and you want to make sure that all transactions are completed, assign the REPORT function to the PROGRAM button. Then before you send a document, press PROGRAM to have the fax unit print a Multi-transaction Report to confirm that the document was sent to all the destinations. (→12-4, 14-12)

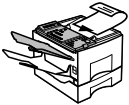

1. Set the document on the fax. (→6-3)

Set the document resolution, contrast, and document type. (→6-4)

You can also select a sender's name with the TTI SELECTOR. (→6-6)

2. Dial the telephone numbers by entering the numbers one right after the other.

Following are the three methods you can use to enter the numbers for Sequential Broadcasting:

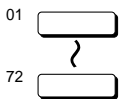

Use the One-touch Speed Dialling buttons to dial up to 72 destinations.

```
TEL=      123 4567
01 CANON INC
```

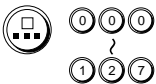

Use the Coded Speed Dialling buttons to dial up to 128 destinations.

```
TEL=      123 4567
★002 CANON INC CA
```

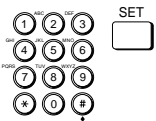

Use regular dialling with the numeric keypad to dial up to 10 destinations, but make sure that you press SET after each number you enter with regular dialling.

You can also press the REDIAL button to redial the last number dialled with the numeric keypad.



---

You must dial the second number within 5 seconds of dialling the first number. All subsequent numbers must be dialled within 10 seconds. If you wait longer than the timeout interval before dialling the next number, the fax will start scanning the document. The timeout interval can be turned off. (→16-11)

---

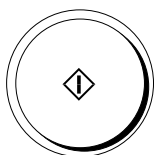

3. After you have entered all of the numbers, press START/SCAN.



---

Regardless of the order you used when dialling, the fax will send the document to the locations you entered in this order: One-touch Speed Dialling numbers, Coded Speed Dialling numbers, then regular dial numbers.

---

#### **To cancel sequential broadcasting**

To cancel a sequential broadcast, press STOP.



After CANCEL DURING TX/RX is displayed, press \*. All destinations are cancelled.

## ***Sending Documents at a Preset Time***

Follow this procedure to set a time for sending. This feature is called *delayed sending* or *timer sending*. Use timer sending to store a document in the memory and then have it sent at a later time when telephone rates are lower.



---

You can set up to five documents for delayed sending.

---



1. Set the document on the fax. (→6-3)

Set the document resolution, contrast, and document type. (→6-4)

You can also select a sender's name with the TTI SELECTOR. (→6-6)



DELAYED TRANSMISSION



- Open both One-touch Speed Dialling panels. Then press DELAYED TRANSMISSION.

DELAYED TX
SET TIME 17:30

- Use the buttons on the numeric keypad to enter the time.

- Enter the time in the 24-hour format (e.g. 1:00 p.m. as 13:00).
- Enter all the numbers, including zeros.



DELAYED TX
SET TIME 23:05



- Press SET.

DELAYED TX
SELECT LOCATIONS

TEL=
------

Dial the other party's fax number.

Use the buttons on the numeric keypad to dial the number. (→6-7)

-or-

Close the One-touch Speed Dialling panels and dial the other party's fax number by pressing a One-touch Speed Dialling button. (→4-26)

-or-

Press CODED DIAL and a three-digit code to dial the number. (→4-28)

-or-

Press DIRECTORY and search for the name to dial the number. (→4-31)

If you make a mistake during dialling, press STOP to return to standby and start again.

TEL= 1 123 4567
09 CALIFORNIA MRKTS





---

You can press more than one speed dialling button to send the document to more than one location after the timer goes off. If you want to enter the numbers with regular dialling for a sequential broadcast, make sure you press SET after every number.

---

DELAYED TX SENDER'S NAME
-----------------------------

SENDER'S NAME CANON DIV. #20
---------------------------------

5. If you want to skip selecting a sender name, go to step 6.

-or-

If you want to select a sender name, press the TTI SELECTOR button until you see the sender name you want to use.

TTI SELECTOR



You can also use the search buttons to scroll up or down the TTI list.

SENDER'S NAME 20 CANON FAX DIV.
------------------------------------



6. Press SET. The fax scans the document and stores it in the memory.

DELAYED TX	2339
SCANNING DOC.	P.001

- The fax will hold the document in the memory until the timer for the document goes off. Then it will send the document to the destinations you specified.
- To cancel a document set for timer sending, use the DELETE FILE button. (→8-9)

# ***Sending a Document with a Subaddress/Password***

You can send documents with ITU-T standard subaddresses and passwords. In order for a transaction to succeed, the subaddresses and passwords on the sending and receiving fax units must match. You can use two methods to send a document with an ITU-T subaddress and password:

- Press a One-touch or Coded Speed Dialling button registered for subaddress/password sending.
- Enter the subaddress and password with the SUBADDRESS and PASSWORD buttons on the operation panel when you send the document.

## ***Subaddress/Password Sending with Speed Dialling***

If you register the subaddress and/or password for a One-touch or Coded Speed Dialling button, the subaddress/password are entered for you automatically after you press the speed dialling buttons. (→4-6, 4-15)

1. To use subaddress/password sending with a speed dialling button, you must first register the subaddress/password for the telephone number when you register the number for One-touch or Coded Speed Dialling. (→4-6, 4-14)

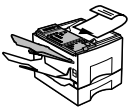

2. Set the document on the fax. (→6-3)

Set the document resolution, contrast, and document type. (→6-4)

You can also select a sender's name with the TTI SELECTOR. (→6-6)

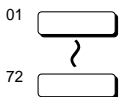

3. Press the One-touch Speed Dialling button registered for subaddress/password sending. (→4-26)

-or-

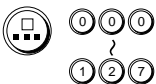

Press the CODED DIAL button followed by the three-digit code for the Coded Speed Dialling number registered for subaddress/password sending. (→4-28)

-or-



Press **DIRECTORY** and search for the name to dial a number registered for subaddress/password sending. (→4-31)

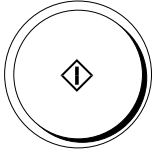

4. Press **START/SCAN**.

TRANSMITTING	0010
SCANNING DOC.	P.001

## **Subaddress/Password Sending with the Operation Panel Buttons**

Note these limitations on entering the subaddress/password with the **SUBADDRESS** and **PASSWORD** buttons on the operation panel:

- If you frequently need to use a subaddress/password to send a document to more than one location, register the number, subaddress, and password for a One-touch or Coded Speed Dialling button so you can use multiple broadcasting. (→6-20)
- You can not use a One-touch or Coded Speed Dialling button for which **TX TYPE** is set for anything other than **REGULAR TX**. (→4-6, 4-14)
- The password setting is optional but required if the other party has set a password on the other fax unit.

Follow this procedure to send a document with a subaddress/password entered with the **SUBADDRESS** and **PASSWORD** buttons on the operation panel.

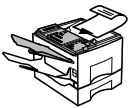

1. Set the document on the fax. (→6-3)

Set the document resolution, contrast, and document type. (→6-4)

You can also select a sender's name with the **TTI SELECTOR**. (→6-6)

2. Dial the telephone number.

Use the buttons on the numeric keypad to enter the telephone number, or use the speed dialling buttons to dial.

To dial with One-touch Speed dialling, press the One-touch Speed Dialling button where the number is registered.

To dial with a Coded Speed Dialling, press **CODED DIAL** and then use the numeric keypad to enter the three-digit dialling code.

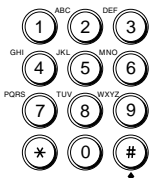

SET

Then press SET.

TEL= 123 4567  
02 JOHN BARRISTER

  
SUBADDRESS

3. Immediately after pressing SET, open both One-touch Speed Dialling panels and press SUBADDRESS.

SUBADDRESS



---

You must press SUBADDRESS within 5 seconds of pressing SET. If you wait longer than the timeout interval before pressing SUBADDRESS, the fax will start scanning the document. The timeout interval can be turned off. (→16-11)

---

  
SET

4. Use the buttons on the numeric keypad to enter the ITU-T subaddress. Then press SET.

TEL= 123 4567  
02 JOHN BARRISTER

PASSWORD

5. If you want to enter a password, press PASSWORD.

PASSWORD



---

You must press PASSWORD within 5 seconds of pressing SET. If you wait longer than the timeout interval before pressing PASSWORD, the fax will start scanning the document. The timeout interval can be turned off. (→16-11)

---

  
SET

6. Use the buttons on the numeric keypad to enter the ITU-T password. Then press SET.

TEL= 123 4567  
02 JOHN BARRISTER



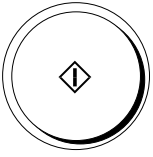

7. Press **START/SCAN**. The fax starts to scan the document.

TRANSMITTING	0021
SCANNING DOC.	P.001

- The fax dials the number and sends the document with the subaddress and password you just entered.
- To cancel the transmission, press **STOP** and press **\*** when you are prompted to confirm the cancellation.
- To cancel a transmission set for delayed or timer sending, use the **DELETE FILE** button. (→8-9)



# Chapter 7

## Receiving Documents

---

This chapter describes the basic receive features.

You can receive document transmission automatically or manually. In the automatic receive mode the fax will receive a document automatically.

In the manual receive mode, if you have installed the optional handset kit you can answer the telephone by picking up the handset on the fax and pressing START/SCAN to start receiving the fax. You can also start manual receiving from an extension telephone with remote receiving.

In the last section of this chapter, we will show you how to put the fax unit in the transfer mode and send all documents automatically to a fax at your home or at another work site.

Receiving Documents Automatically .....	7-2
Setting the Automatic Receive Mode .....	7-2
Messages Displayed When Receiving a Document .....	7-2
Turning on and Adjusting the Auto Switch Time .....	7-4
Receiving Documents Manually with the Optional Handset .....	7-6
Receiving a Document Manually at the Fax .....	7-6
Receiving a Document Manually with an Extension Telephone .....	7-7
Changing the Remote Receive ID .....	7-8
Cancelling Receiving a Document .....	7-10
Transferring Documents .....	7-11
Before You Set Up Document Transfer .....	7-11
Setting Up the Fax for Document Transfer .....	7-12
Turning the Transfer Mode ON and OFF .....	7-15
Changing the Transfer Settings .....	7-16
Cancelling the Transfer Settings .....	7-17

# Receiving Documents Automatically

After you take your fax out of the box and set it up, it is set to receive documents automatically. Use automatic receiving for a fax on a dedicated telephone line that you do not need for telephone voice communication.

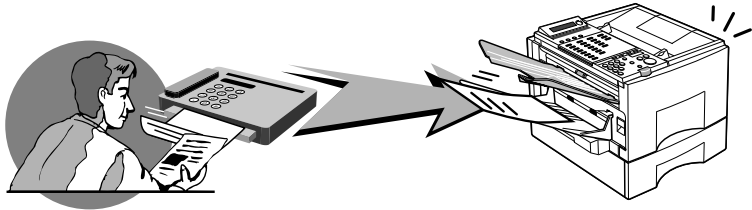

## Setting the Automatic Receive Mode

○  
MANUAL RX

Check the indicator above the MANUAL RX button. When this indicator is off, the fax is in the automatic receive mode.



When a fax document is sent to you, your fax unit receives the document automatically. During receiving a series of brief messages report the progress of the reception by displaying the transaction number, name and telephone of the caller, and the transmission mode.



---

If you install the handset and you don't want the fax to ring when the other party sends to you, turn the ringer volume switch to OFF.

---

## Messages Displayed When Receiving a Document

This is a summary of the messages you will see displayed while your fax is receiving a document. While you are receiving a document, information about the document and other party is displayed.

### Receiving a transmission

26/12 '97 FRI 23:31 RECEIVE
--------------------------------

### Transaction number

Every document is assigned a transaction number as soon as it is received.

26/12 '97 FRI 12:20 TX/RX NO. 5001	Transaction Number
---------------------------------------	--------------------

Documents received are assigned transaction numbers in ascending order starting with the number 5001 up to 9999. After 9999 is reached, numbering starts from 5001 again.

#### **Other party's fax number**

The other party's facsimile number is displayed only if it is registered on the other party's fax machine.

26/12 '97 FRI 11:34 123 4567
---------------------------------

#### **Other party's name**

According to the type of machine the other party is using to send the document, you may also see the other party's name displayed alternately with the telephone number.

26/12 '97 FRI 11:34 CANON INC. K.SATO
--

#### **ECM reception mode**

26/12 '97 FRI ECM RX P.001
-------------------------------

If the other party's fax supports ECM sending, your fax receives every document in the error correction mode (ECM). (→16-12)

#### **Successful reception**

You will see these alternating messages displayed after a document is successfully received.

26/12 '97 FRI 11:34 RECEPTION OK
-------------------------------------

26/12 '97 FRI 11:34 TX/RX NO. 5011
---------------------------------------

You can also confirm reception of a document by printing an Activity Report or an Activity Management Report. (→14-7)

### Receive error messages

Here are few of the most common error messages.

The fax has run out of paper while printing or copying a document:

SUPPLY REC. PAPER

Open the paper cassette and add paper to the paper cassette. As soon as you re-fill the paper cassette and close it, the remainder of the document in the memory is printed. (→2-22)

The toner cartridge has run out of toner while printing or copying a document:

REPLACE CARTRIDGE

Open the printer cover and replace the toner cartridge. As soon as you close the cover, the fax returns to standby and the remainder of the document in the memory starts printing automatically. (→15-14)



If you see any other error messages, note the message then look it up in the error message table. (→15-26)

## Turning on and Adjusting the Auto Switch Time

If you have installed the optional handset or connected an extension telephone to the fax machine, follow this procedure to set the ring time before the fax switches automatically to the document receive mode while in the manual receive mode. This allows more time for you to pick up the handset and answer the telephone for voice communication before the fax switches to the receive mode.

1. Open the RX SETTINGS menu.

Open both One-touch Speed Dialling panels. Then press DATA REGISTRATION.



DATA REGISTRATION



REGISTRATION  
1.DATA REGISTRATION

SET



Press SET.

DATA REGISTRATION  
1.USER SETTINGS



Press the search buttons until you see the display below.

DATA REGISTRATION  
4.RX SETTINGS



Press SET.

RX SETTINGS  
1.ECM RX

2. Open the MANU/AUTO SWITCH menu.



Press the search button until you see the display below.

RX SETTINGS  
2.MAN/AUTO SWITCH



Press SET.

MAN/AUTO SWITCH OFF



Press the search buttons until you see the display below.

MAN/AUTO SWITCH ON



Press SET.

F/T RING TIME 15SEC

3. Set the amount of time the fax waits before automatically switching to the document receive mode.

Use the buttons on the numeric keypad to enter a number for the time (01 to 99) in seconds.

-or-

Press the search buttons to increase or decrease the number setting.



Press SET.



4. Press STOP to return to standby.



5. Press MANUAL RX to put the fax in the manual receive mode whenever you want to take advantage of the MAN/AUTO SWITCH feature. (→16-12)



## Receiving Documents Manually with the Optional Handset

When you use manual receiving, this means you can monitor all incoming calls yourself by picking up the handset every time the fax rings. If you pick up the handset and determine the call is from another person, start your conversation. If you hear a slow beep tone, this means the call is a fax transmission. To receive the document, just press START/SCAN and then hang up the handset.

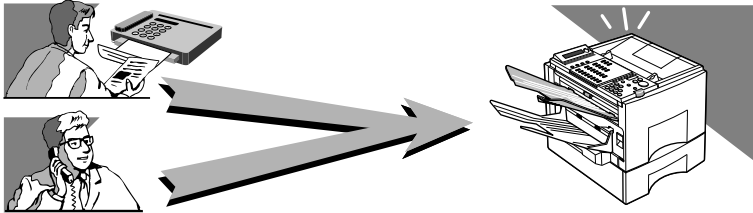

## Receiving a Document Manually at the Fax

Follow this procedure to receive a document manually at the fax.



---

Before you can use this feature, you must install the optional handset kit or a regular telephone. (→2-20) Make sure the document is not set on the ADF.

---



1. Press MANUAL RX to set the fax in the manual receive mode. The MANUAL RX indicator should be on.



2. Every time you hear the telephone ring, pick up the handset.  
If you hear someone on the line, you can talk.

-or-

If you hear a slow beep tone, this means another fax is trying to send you a document.





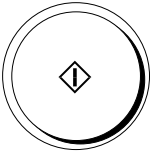

3. Press START/SCAN to start receiving the document. Then hang up the handset by placing it back in the handset cradle. The fax will start to receive the document.

The fax will make a beeping sound if the handset is not completely on its handset cradle. This is called the offhook alarm. The offhook alarm can be turned off. (→16-6)

## Receiving a Document Manually with an Extension Telephone

You can connect one extension telephone to the facsimile unit. (→2-22) When the telephone rings with the fax in the manual receive mode, you can use the extension telephone to start receiving the document without walking over to the fax machine. This is called *remote receiving*.

1. Make sure the extension telephone is connected properly. (→2-22)
2. Check the operation panel and make sure the fax is in the manual receive mode. The MANUAL RX indicator should be on. If it is off, press MANUAL RX to turn on the indicator and switch the fax into the manual receive mode.



3. When the connected extension phone rings, pick up the handset.  
If you hear someone on the line, you can start talking to the other party.

-or-

If you hear a slow beep, dial 25 on the extension telephone and hang up to start receiving the document.



---

You can change the number for the remote receiving ID (00 to 99), turn the feature off, or set the fax to start receiving by just hanging up the handset. (→7-6)

---

If you have set the fax to receive by hanging up, after hearing a slow-beep tone, hang up the handset.

## Changing the Remote Receive ID

Follow this procedure to change the remote receive ID or to set the fax to receive a document by just hanging up the handset of the extension telephone.

1. Open the RX SETTINGS menu.

Open both One-touch Speed Dialling panels. Then press DATA REGISTRATION.



DATA REGISTRATION



SET



REGISTRATION  
1.DATA REGISTRATION

Press SET.

DATA REGISTRATION  
1.USER SETTINGS

Press the search buttons until you see the display below.



DATA REGISTRATION  
4.RX SETTINGS

SET



Press SET.

RX SETTINGS  
1.ECM RX

2. Press the search buttons until you see the display below.



RX SETTINGS  
3.REMOTE RX

SET



3. Press SET.

REMOTE RX  
ID CALL#



4. Press the search buttons to display the item you want to change.

ID CALL #	Allows you to pick up the handset of the extension telephone connected to the fax and start receiving a document by dialling the remote switching ID. The default is 25, or you can set your own two-digit ID.
HOOK	Allows you to start receiving by just hanging up the handset of the extension telephone connected to the fax.
OFF	Turns off the remote receive feature.



**To change the ID call number**

Press the search buttons until you see the display below.

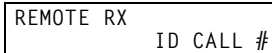

Press SET.

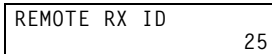

Use the buttons on the numeric keypad to enter a new number (00 to 99) for the ID.



-or-

Press the search buttons to increase or decrease the number.



Then press SET.



**To set the extension phone to hook document reception mode**

Press the search buttons until you see the display below.

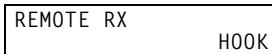

Press SET.

When the fax rings, pick up the handset of the extension telephone and hang up the extension phone to start receiving.



### To turn off remote receiving

Press the search buttons until you see the display below.

```
REMOTE RX          OFF
```



Press SET.



5. Press STOP to return to standby.

## Cancelling Receiving a Document

Follow this procedure to cancel receiving a document.

1. Visually check the display to confirm that a document is being received.

```
26/12 '97 FRI 12:20
RECEIVE          5012
```



2. To cancel the reception, press STOP.

The following message is displayed:

```
CANCEL DURING TX/RX
YES=(*) NO=(#)
```

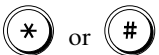

3. Press \* to cancel receiving the document or press # to let receiving continue. After you press \* an alarm sounds, document reception is cancelled, and the following messages are displayed.

```
26/12 '97 FRI 12:25
STOP KEY PRESSED
```

```
26/12 '97 FRI 12:25
TX/RX NO.        5012
```

If the receive report feature is on or set to PRINT ERROR ONLY, an RX REPORT also prints. (→16-7)

```
PRINTING REPORT
```

```

26/12 '97 13:23 FAX 212 833 4423 WORLD ESTATE, INC. 001
* * * * *
* RX REPORT *
* * * * *

INCOMPLETE RECEPTION

TX/RX NO          5025
CONNECTION TEL    1 213 978 3314
SUBADDRESS        #005
CONNECTION ID     BELZER, INC.
ST. TIME          26/12 15:49
USAGE T.          00'17"
PGS.              0
RESULT            NG
                  0 STOP

```

Then the fax returns to standby.

## Transferring Documents

The transfer mode tells the fax to receive documents and then transfer them automatically to a fax at your home or at another work site. The day and time for the fax unit to switch to the transfer mode can be pre-set. This feature is especially convenient for receiving important documents coming from countries overseas several time zones removed from your own.

### Before You Set Up Document Transfer

Note these important points before you create a transfer setup file:

- You can create only one transfer setup file.
- In order for the fax unit to transfer documents to a destination you must enter the destination telephone number of the fax unit with a speed dialling button. This means the destination fax unit must be registered on the fax for a One-touch Speed Dialling button or a Coded Speed Dialling code. (→4-6, 4-14)
- You can set the fax to transfer documents only from selected originators. In order to select an originator, you have to register the telephone number of the originator's fax unit on your fax unit for a One-touch Speed Dialling button or a three-digit Coded Speed Dialling code. (→4-6, 4-14)

# Setting Up the Fax for Document Transfer

Follow the procedure below to create a file for switching the fax automatically into the transfer mode.

1. Open the TRANSFER menu.

Open both One-touch Speed Dialling panels. Then press DATA REGISTRATION.



DATA REGISTRATION



SET



REGISTRATION  
1.DATA REGISTRATION

Press SET.

DATA REGISTRATION  
1.USER SETTINGS

Press the search buttons until you see the display below.



DATA REGISTRATION  
6.FILE SETTINGS

SET



Press SET.

FILE SETTINGS  
1.CONFID. MAILBOX

Press the search buttons until you see the display below.



FILE SETTINGS  
6.TRANSFER

SET



Press SET.

TRANSFER  
1.SETUP FILE

2. Press SET. Then press the search buttons to scroll the display so you can see each setting.

SET



SETUP FILE  
1.FILE NAME

SETUP FILE  
6.PRINT RX DOC.



3. Press SET then follow the summary in the table below to perform the settings.



4. Press STOP to return to standby.

### Transfer Setup Summary

The default settings, shown in bold below, remain in effect unless you change them.

1.FILE NAME	Enter a file name up to 24 characters long.
2.SELECT LOCATIONS	Select the numbers of the fax machines where you want documents transferred.  TEL = Close the One-touch Speed Dialling panels and press a One-touch Speed Dialling button or press the CODED DIAL button followed by a three-digit code for the Coded Speed Dialling number to enter the number of the fax machine where you want documents transferred. <i>The telephone number of the destination fax must be registered for One-touch or Coded Speed Dialling on your fax.</i>
3.PASSWORD	0000-9999  Enter a four-digit number (0000-9999) to protect the transfer file settings. <i>Use of a password is recommended.</i> This operation password protects the transfer file from unauthorized access to your settings. You will also need to enter this password when you put the fax in the document transfer mode.
4.SELECT ORIG UNIT	Allows you to set the fax to receive and relay documents only from originator fax units that you designate.  <b>OFF</b> All fax transmissions are received and transferred.  ON The fax machine receives and transfers transmissions only from fax units that you designate by fax telephone number.  TEL = Press the One-touch Speed Dialling button or press the CODED DIAL button followed by the three-digit code to designate the originator fax machines for receive and transfer. <i>The telephone number of the originator fax must be registered for One-touch or Coded Speed Dialling on your fax.</i>

### Transfer Setup Summary (Cont'd)

5.TIME SETUP*	Sets the time to move the fax into and out of the transfer mode. If you do not set the timer, you can still switch the fax into the transfer mode manually.	
1.START TIME	Set a time to move the fax automatically into the transfer mode.	
<b>EVERY DAY</b>	:	Sets the fax to move into the transfer mode every day. You can set up to 5 starting times for every day of the week.
SELECT DAYS	1.SUN to 7.SAT	Sets the fax to move into the transfer mode only on selected days of the week.
	:	You can set up to 5 starting times for the selected days.
2.END TIME	Sets the time for the fax to leave the transfer mode and return to the normal mode.	
<b>EVERY DAY</b>	:	Sets the fax to move out of the transfer mode every day. You can set up to 5 end times for every day of the week.
SELECT DAYS	1.SUN to 7.SAT	Sets the fax to move out of the transfer mode on selected days of the week. You can set up to 5 end times for the selected days.
	:	
6.PRINT RX DOC.	Sets the fax to print a copy of the transferred document at the transfer unit.	
	<b>OFF</b>	Received and transferred documents are not printed at the transfer unit.
	ON	A copy of every document received and transferred is printed at the transfer unit.
	# OF RX COPIES	To enter the number of copies (01-99) use the numeric keypad to enter the number or press the search buttons to increase or decrease the number and press SET.

\* The following settings are valid: You can set EVERY DAY for the start time and then use SELECT DAYS to set end times. You can also set SELECT DAYS for start times and then use the EVERY DAY setting for the end time. However, you can not set both EVERY DAY and SELECT DAYS for the start time or end time.



# Turning the Transfer Mode ON and OFF

You can use this procedure to move the fax into and out of the transfer mode if the timer has not been set to switch the fax in and out of the transfer mode automatically. If the timer has been set to move the fax into and out of the transfer mode automatically, you can still use this procedure to put the fax in the transfer mode before the timer switches the fax into the transfer mode.

## Turning Transfer Mode ON

Follow this procedure to turn the transfer mode on manually at any time.



TRANSFER

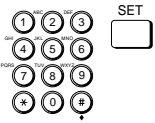

1. Open both One-touch Speed Dialling panels. Then press TRANSFER.

PASSWORD

2. If you have registered a password, use the buttons on the numeric keypad to enter your four-digit password, then press SET.

TRANSFER

The fax is now in the transfer mode and will transfer documents to the destinations you specified in the transfer setup file.

## Turning Transfer Mode OFF

Follow this procedure to turn the transfer mode off manually at any time.



TRANSFER

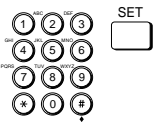

1. Open both One-touch Speed Dialling panels. Then press TRANSFER.

PASSWORD

2. If you have registered a password, use the numeric keypad to enter your four-digit password, then press SET.

26/12 '97 FRI 08:30

The fax is now in the standby mode and is ready for normal operation.

## Changing the Transfer Settings

Follow this procedure to change settings in the transfer setup file.

1. Open the TRANSFER menu. (→7-12)

TRANSFER  
1.SETUP FILE

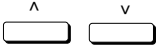

2. Press the search buttons until you see the display below.

TRANSFER  
2.CHANGE DATA



3. Press SET.

CHANGE DATA  
PASSWORD \_

If you have not set the password, you can skip the next step.

4. Use the buttons on the numeric keypad to enter the four-digit password protecting the transfer setup file. Then press SET.

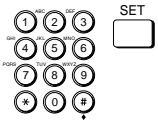

5. Press the search buttons to display the desired setting.

CHANGE DATA  
1.FILE NAME



CHANGE DATA  
6.PRINT RX DOC.



6. With the setting you want to change on the display, press SET.

7. To change the settings, follow the same procedures you used to set up the transfer setup file. (→7-12)



---

To delete any settings, press CLEAR and press SET.

---



8. Press STOP to return to standby.

## Cancelling the Transfer Settings

Follow this procedure to delete the transfer setup file and cancel the transfer settings.

1. Open the TRANSFER menu. (→7-12)



TRANSFER  
1.SETUP FILE



2. Press the search buttons until you see the display below.



TRANSFER  
3.DELETE FILE



3. Press SET.



DELETE FILE  
PASSWORD \_

If you have not set the password, you can skip the next step.

4. Use the buttons on the numeric keypad to enter the four-digit password and press SET.

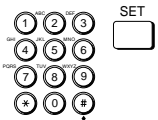

DELETE FILE  
FILE DELETED

5. Press STOP to return to standby.





# Chapter 8

## Using the Memory Features

---

This chapter shows you how to use the memory features of the fax unit.

Some operations require that a document reside in the memory before it is sent. For example, if you scan a document and set the timer, it will wait in the memory until it is time for the fax to send the document.

If you scan a document for polling sending, the document will wait in the memory until it is requested for sending by a polling request from another fax. While such documents are residing in memory, you can view their transaction numbers, list them in a printout, delete them before they are sent, or re-route them to another destination.

Using the Memory Features .....	8-1
When the Fax Displays RECEIVED IN MEMORY .....	8-2
Displaying the Transaction History .....	8-3
Printing a Memory List .....	8-4
Printing a Document in the Memory .....	8-5
Re-sending a Document to the Same Destination .....	8-6
Sending a Document in Memory to a Different Destination .....	8-7
Erasing a Document from the Memory .....	8-8
Deleting a Document with the DELETE FILE Button .....	8-9
Deleting a Document with the MEMORY REFERENCE Button .....	8-9
Setting Up and Using a Memory Box .....	8-10
Before You Create Memory Boxes .....	8-11
When You Create a Memory Box .....	8-11
Creating a Memory Box .....	8-13
Changing the Memory Box Settings .....	8-19
Cancelling a Memory Box .....	8-21
Sending a Document Stored in the Memory Box .....	8-22
Printing a Document Received in a Memory Box .....	8-23
What Happens to Memory after a Power Failure .....	8-24
How Your Registered Data Is Protected .....	8-24
About the Backup Battery .....	8-25

# When the Fax Displays **RECEIVED IN MEMORY**

If paper or toner runs out while you are receiving a document, the fax will automatically store the unprinted pages of the document in the memory and display these messages:

RECEIVED IN MEMORY

RECEPTION OK

26/12 '97 FRI 12:30  
TX/RX NO. 5033

1. Check the LCD display and the indicators below the display.

REC. PAPER



Add paper to the paper cassettes, if the REC. PAPER indicator is on and if you see this message: (→2-22)

SUPPLY REC. PAPER

CHANGE CARTRIDGE



Replace the toner cartridge if the CHANGE CARTRIDGE indicator is on and if you see this message: (→15-14)

REPLACE CARTRIDGE

2. As soon as you close the re-filled paper cassette, or close the printer cover over the newly installed toner cartridge, the pages stored in the memory are printed.
  - As each page is printed, it is deleted from the memory.
  - If the memory becomes full, you will not be able to receive the remaining pages. Contact the other party and request that the document be sent again.
  - The fax can store up to 80 A4-size pages\* in the memory. With the optional memory kit you can receive up to 592 pages in the memory. For details about the optional memory kits, contact your authorized Canon dealer.
  - A memory backup function is provided to save the contents of the memory for up to approximately 12 hours during a power failure.

\* Based on Canon FAX Standard Chart No. 1, Standard Mode.

# Displaying the Transaction History

Follow this procedure to display results of transactions. This feature is convenient when you want to check the status of a transaction without printing an activity management report.

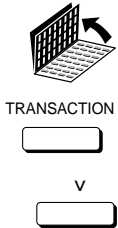

1. Open both One-touch Speed Dialling panels and press TRANSACTION.

2. Press the down arrow button to view the most recent transmission.

```
14:08 0015 TX OK
CANON CANADA
```

The most recent transmission is displayed first.

- Press the up and down arrows to view the list of transactions.
- All transmissions are displayed first, then the receptions are displayed.
- The transaction numbers for documents sent, numbered 0001 to 4999, are displayed then the transaction numbers for documents received, numbered 5001 to 9999, are displayed. The transaction numbers are stored in descending order, from the larger numbers to the smaller numbers.
- Note the following notations used to tell you about the status of the transaction:

Notation	Meaning
OK	Document transaction has been completed.
NG	Transaction failed.
HOLDNG	Document is being held in the memory for delayed sending or is waiting to be polled.
TRANSM	Document is currently being sent or received.
--:--	No time is displayed for a document currently being sent or being stored in the memory for pending transmission.



3. Press STOP to return to standby.

# Printing a Memory List

Follow this procedure to print a list of all documents currently stored in the memory.



MEMORY REFERENCE



1. Open both One-touch Speed Dialling panels. Then press MEMORY REFERENCE.

If no documents are currently stored in the memory, you will see this message:

NO DOC. STORED

If documents are stored in the memory the first item on the MEMORY REFERENCE menu is displayed.

MEMORY REFERENCE  
1.DOC. MEMORY LIST

SET



2. Press SET to start printing the memory list.

PRINTING REPORT

26/12 '97 15:03 FAX 833 4423		WORLD ESTATE, INC.				001	
* * * * * * DOC. MEMORY LIST * * * * * *							
TX/RX NO	MODE	CONNECTION	TEL/ID	PGS.	SET TIME	ST. TIME	SENDER NAME
5443	DELAYED TX	[#10]	J.SMITH	5	26/12 17:40	00:33	R.LOUIS



# Printing a Document in the Memory

Follow this procedure to print a document in the memory.



---

To select a document for printing, you must know its transaction number. You may want to print a memory list for reference. (→8-5)

---



MEMORY REFERENCE



1. Open both One-touch Speed Dialling panels. Then press MEMORY REFERENCE.

```
MEMORY REFERENCE
1.DOC. MEMORY LIST
```

2. Press the search buttons until you see the display below.

```
MEMORY REFERENCE
3.PRINT DOCUMENT
```



3. Press SET to set up to print.

```
PRINT DOCUMENT
TX/RX NO. 0002
```

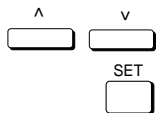

Press the search buttons to display the transaction number of the document you want to print. Then press SET.

```
PRINT 1ST PAGE ONLY?
YES=(*) NO=(#)
```



---

If you want to know the destination telephone number and time of the document, press the cursor buttons (<>).

---

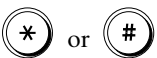

Press \* to print only the first page of a multi-page document, or press # to print the entire document.

```
TX/RX NO. 0358
PRINTING P.001/001
```



4. Press STOP to return to standby.

# Re-sending a Document to the Same Destination

Follow this procedure to re-send a document to the same destination.  
The fax prints an error transmission report as soon as a transmission fails.

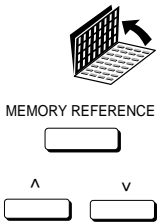

1. Open both One-touch Speed Dialling panels. Then press MEMORY REFERENCE.

```
MEMORY REFERENCE
1.DOC. MEMORY LIST
```

2. Press the search buttons until you see the display below.

```
MEMORY REFERENCE
2.MEMORY RETRASMT
```

3. Press SET then select the document you want to send.

```
MEMORY RETRASMT
TX/RX NO. 0038
```

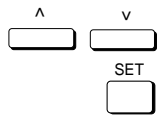

4. Press the search buttons to display the transaction number of the document you want to send. Then press SET.



---

If you want to know the destination telephone number and time of the document, press the cursor buttons (<>).

---

The fax sends the document to the number of the failed transmission. After the document is sent, it is erased from the memory.

# Sending a Document in Memory to a Different Destination

Follow this procedure to select another destination for a document waiting for timer sending or waiting to be polled. After the document is sent to another destination, it is erased from the memory.



---

To select a document for sending, you must know its transaction number. You may want to print a memory list for reference. (→8-4)

---



MEMORY REFERENCE



1. Open both One-touch Speed Dialling panels. Then press MEMORY REFERENCE.

MEMORY REFERENCE  
 1.DOC. MEMORY LIST

2. Press the search buttons until you see the display below.

MEMORY REFERENCE  
 4.RESEND DOCUMENT



3. Press SET then select the document you want to send.

RESEND DOCUMENT  
 TX/RX NO.     0010

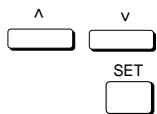

4. Press the search buttons to display the transaction number of the document you want to send. Then press SET.

RESEND DOCUMENT  
 SELECT LOCATIONS

TEL=



---

If you want to know the destination telephone number and time of the document, press the cursor buttons (<>).

---

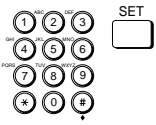

5. Dial the fax number.

Use the buttons on the numeric keypad to dial the telephone number and press SET.

-or-

Use One-touch Speed Dialling, Coded Speed Dialling, or Group Dialling to dial the number.

Press SET.



RESEND DOCUMENT  
SENDER'S NAME

SENDER'S NAME  
03 CANON INC.

6. Enter the sender's name.

Press TTI SELECTOR and keep pressing it until the sender's name you want appears in the display. You can also use the search buttons to scroll up and down the TTI list.

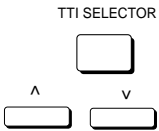

SENDER'S NAME  
06 CANON: J.SMITH



Press SET. The fax sends the document to the number you dialled. After the document is sent, it is erased from the memory.

## Erasing a Document from the Memory

Follow this procedure to erase a document from the memory. To delete a document from the memory, you can use the DELETE FILE button or the MEMORY REFERENCE button.



---

To select a document for deletion, you must know its transaction number. You may want to print a memory list for reference. (→8-4)

---

## Deleting a Document with the DELETE FILE Button

DELETE FILE



1. Press DELETE FILE.

DELETE DOCUMENT  
TX/RX NO. 0057



2. Open both One-touch Speed Dialling panels.

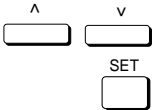

3. Press the search buttons to display the transaction number of the document you want to delete. Then press SET.

OK TO DELETE?  
YES=(\*) NO=(#)



---

If you want to know the destination telephone number and time of the document, press the cursor buttons (<>) before pressing SET.

---



4. Press \* to delete the selected document or press # to cancel the deletion. After you press \* the document is erased.

TX/RX NO. 0004  
ERASING END



5. Press STOP to return to standby.

## Deleting a Document with the MEMORY REFERENCE Button



MEMORY REFERENCE



1. Open both One-touch Speed Dialling panels. Then press MEMORY REFERENCE.

MEMORY REFERENCE  
1.DOC. MEMORY LIST



2. Press the search buttons until you see the display below.

MEMORY REFERENCE  
5.DELETE DOCUMENT



3. Press SET.

```
DELETE DOCUMENT
TX/RX NO.      0001
```

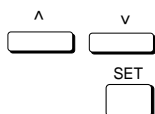

4. Press the search buttons to display the transaction number of the document that you want to delete. Then press SET.



If you want to know the destination telephone number and time of the document, press the cursor buttons (<>) before pressing SET. If the transaction is displayed with a # mark, the document is being held in the memory for re-dialling and sending.

```
OK TO DELETE?
YES=(*) NO=(#)
```



5. Press \* to delete the selected document or press # to cancel the deletion. After you press \*, the document is erased.

```
TX/RX NO.      0004
ERASING END
```



6. Press STOP to return to standby.

## Setting Up and Using a Memory Box

In this section we will show you how to set up a memory box and use it to send and receive documents. A memory box is a location in the memory you can create to store scanned or received documents for printing or transmitting to other destinations. The main advantage to using the memory box for sending and receiving is that you can handle all transmissions with ITU-T passwords and subaddresses.

The ITU-T subaddress and password serve the same purpose as the bank account number and a personal identification number on your bank card. Just as you can not complete a bank transaction without your account number and your personal identification number, you can not complete a memory box facsimile transaction if the subaddress and password do not match.



---

A subaddress or password can be up to 20 digits long and consists of numbers, \*, #, or spaces.

---

## Before You Create Memory Boxes

Before you set up a memory box, there are a few things you should know about the other party's fax machine to ensure efficient transactions.

You have to know how the other party is using the subaddress and password:

- If the other party has set a subaddress and password, you must register both a subaddress and password for the memory box.
- If the other party has set a subaddress only, then you must also register a matching subaddress.
- If the other party has set a password only, inform them that they must register a subaddress, or a subaddress and password. *Both fax units must register an ITU-T subaddress.*





---

For the most efficient use of the memory box, register the numbers of all parties who will be receiving your documents or sending you documents for a One-touch or Coded Speed Dialling number.

---

## When You Create a Memory Box

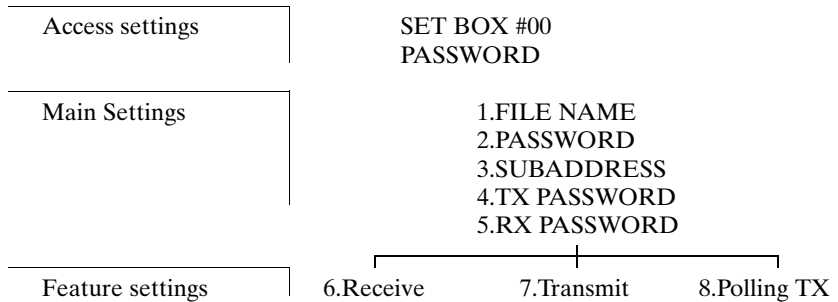
This is a brief summary of what to do when you create or change settings for a memory box.



## Access Settings

### SET BOX

A two-digit code (00-99) you assign to the box to select it when you need to scan documents into the box or to open it to view or change the settings. The box number and file name appear in printed reports for reference.

### PASSWORD

If you created a password when you created the memory box (below 2.PASSWORD), you will have to enter the password to see the rest of the settings.

## Main Settings

### 1.FILE NAME

A personal name you can assign to the memory box to identify it in printed reports.

### 2.PASSWORD

A four-digit password you assign to the memory box to protect the settings from unauthorized access. You must also use this password and the box number to print documents stored in the memory box. Assigning a password is optional, but strongly recommended, especially if you want to keep the memory box setup and the documents you receive confidential.

### 3.SUBADDRESS

This is the ITU-T subaddress.

### 4.TX PASSWORD

This is your TX password. TX password is only for polling sending. Your TX password must match the ITU-T password with which the other party calls you. If they do not match the other party will not receive your document.

### 5.RX PASSWORD

This is your RX password. Your RX password must match the ITU-T password assigned to documents that you receive. If the passwords do not match, your fax will not receive the document.

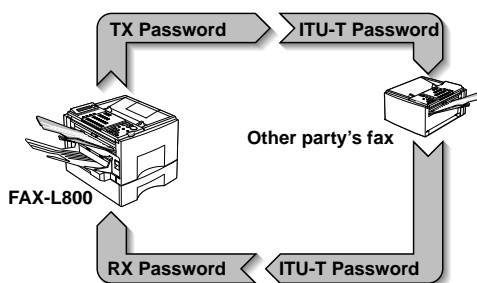

The main settings apply to all three features below, including RECEIVE, TRANSMIT, and POLLING TX.



## Feature Settings

### 6.RECEIVE

Allows you to set up how documents are handled in the memory box after they are received. You can set the memory box to check the ID (telephone number) of the originator, and specify that the received document be held in the memory box and not printed.

### 7.TRANSMIT

Allows you to set up memory box transmission. You can set the memory box to relay documents immediately or store them in the memory box. You can set the timer for all documents set for sending from the memory box.

### 8.POLLING TX

Allows you to set up the memory box as a polling station to hold scanned or received documents in the memory box and wait for a polling request from another fax. After the subaddress and passwords are matched, the stored documents are sent to the polling fax.

## Creating a Memory Box

Follow this procedure to create a memory box.

1. Open the MEMORY BOX menu.

Open both One-touch Speed Dialling panels. Then press DATA REGISTRATION.



DATA REGISTRATION



SET



REGISTRATION  
1.DATA REGISTRATION

Press SET.

DATA REGISTRATION  
1.USER SETTINGS

Press the search buttons until you see the display below.



DATA REGISTRATION  
6.FILE SETTINGS

Press SET.

SET



FILE SETTINGS  
1.CONFID. MAILBOX

Press the search buttons until you see MEMORY BOX.



FILE SETTINGS  
3.MEMORY BOX



Press SET.

MEMORY BOX  
1.SETUP FILE

2. Give the memory box a number.



Press SET.

SETUP FILE  
SET BOX # 00

Use the buttons on the numeric keypad to enter a two-digit code for the memory box.

- You can enter a number from 00 to 99 for the memory box number.

You can also use the search buttons to change the number. Press the down arrow to increase the number and the up arrow to decrease the number.

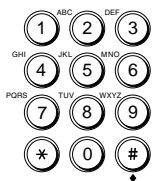

SETUP FILE  
SET BOX # 33



Press SET.



3. Press the search buttons to display the desired setting.

SETUP FILE  
1.FILE NAME

SETUP FILE  
8.POLLING TX



4. With the item displayed that you want to set press SET. Then perform the settings as described in the summary below.



5. When you are finished setting up the memory box, press STOP to return to standby.

## Memory Box Setup Summary

The default settings, shown in bold, remain in effect unless you change them.

---

1.FILE NAME	NAME
	This setting allows you to enter a personal name for the memory box that will appear in printed reports. Enter a name of up to 24 characters and press SET.
2.PASSWORD	0000 to 9999
	This operation password protects your memory box settings. After you set this password, you will have to enter the password before you can view or change the settings for the memory box. You will also have to enter this password to print a document received in the memory box.
3.SUBADDRESS	0-9, *, #, spaces (20 digits)
	The ITU-T subaddress for the memory box. <i>This setting is not optional.</i> You must enter a subaddress here in order to use the memory box. Enter a subaddress of up to 20 digits long. In addition to numbers, the subaddress may include *, #, and spaces.
4.TX PASSWORD	0-9, *, #, spaces (20 digits)
	The ITU-T standard TX password for your memory box. TX password is only for polling sending. This password must match the ITU-T password with which the other party calls you in order for the transaction to succeed. If your TX password does not match the ITU-T password on the other fax machine, your document will not be received by the other party's fax.
5.RX PASSWORD	0-9, *, #, spaces (20 digits)
	The ITU-T standard RX password for your memory box. This password must match the ITU-T password sent with a document to your fax in order for the transaction to succeed. If your RX password does not match the TX password sent with the document from the other party's fax, your fax will not receive the document.

---

## Memory Box Setup Summary (Cont'd)

---

6.RECEIVE	Determines whether or not the document is received in the memory box and how it is received.
<b>NO</b>	Documents are not received in the memory box.
<b>YES</b>	Documents are received in the memory box and you can do some additional settings to determine how they are received. If selected, you can turn on checking the originator, printing the document, and printing method.

---

1.SELECT ORIG UNIT	Determines whether your fax checks to make sure the originator of the transmission is registered on your fax. To be registered on your fax, the originator's telephone number must be registered for a One-touch or Coded Speed Dialling button on your fax unit.
<b>OFF</b>	Your fax receives an incoming document even if the originator is not registered on your fax.
<b>ON</b>	Your fax will receive the document only if the originator is registered for a One-Touch or Coded Speed Dialling button on your fax unit.
<b>TEL =</b>	After you turn SELECT ORIG UNIT on, press the appropriate One-touch Speed Dialling button or press the CODED DIAL button followed by the appropriate three-digit code to register the number of the originator and press SET. <i>In order to register the originator's telephone number, the number must be registered for a One-touch or Coded Speed Dialling button.</i>

---

2.PRINT RX DOC.	Determines whether to print a received document.
<b>ON</b>	Documents will be printed when they are received in the memory box and you can set how they will be printed.
<b>OFF</b>	Documents received in the memory box are not printed.

---

1.PRINT METHOD	If you turn on PRINT RX DOC., you can also set the print method.
<b>AUTO</b>	A document will print automatically as soon as it is received in the memory box.
<b>MAN.</b>	You will have to manually print documents received in the memory box.

---

## Memory Box Setup Summary (Cont'd)

2.# OF RX COPIES	01 COPIES	If you turn on PRINT RX DOC., use this setting to specify the number of copies you want to print (01-99).
7.TRANSMIT	<b>NO</b>	Documents are not transmitted from the memory box.
	<b>YES</b>	Documents are transmitted from the memory box.
1.SELECT LOCATIONS	Allows you to select the destinations of the documents to be transmitted from the memory box. Press the appropriate One-touch button or press the CODED DIAL button followed by the appropriate three-digit code to enter numbers for dialling.	
2.TX DOCUMENT	Determines whether to (1) transmit documents received in the memory box from another fax or (2) transmit documents scanned into the memory box.	
1.RECEIVED DOCUMENT	<b>TRANSMIT</b>	Documents received in the memory box can be transmitted to other destinations.
	<b>NOT TRANSMIT</b>	Documents received in the memory box can not be transmitted to other destinations.
TX REPORT	If you turn on TRANSMIT for RECEIVED DOCUMENT, you can set the memory box to send a transaction report to the originator every time it sends a received document to another destination. This setting is effective only when 6.RECEIVE – 1.SELECT ORIG UNIT is ON.	
	<b>TRANSMIT</b>	A transaction report for the transmission is sent to the originator.
2.SCAN DOCUMENT	Determines whether to transmit documents scanned in the memory box.	
	<b>TRANSMIT</b>	Documents scanned into the memory box are transmitted.
	<b>NOT TRANSMIT</b>	Documents scanned into the memory box are not transmitted.

### Memory Box Setup Summary (Cont'd)

---

3.TX START TIME	Allows you to set the timer for the transmission of a document received or scanned into the memory.
<b>EVERYDAY</b>	Enter the time (in 24-hour format) that you want to transmit the documents from the memory box. You can set up to 5 times to transmit documents every day.
SELECT DAYS	Select one or more days of the week to transmit documents from the memory box. Enter the time (in 24-hour format) that you want to transmit the documents from the memory box. You can set up to 5 times for each day you select.
8.POLLING TX	Determines whether the memory box is to be used as a polling box. A polling box holds a document in the memory until the fax is polled by another fax unit requesting that the document be sent.  <b>NO</b> The memory box is not set up as a polling box. The documents received or scanned into the memory box are not sent in response to a polling request from another fax unit.  <b>YES</b> The memory box is set up as a polling box. The documents received or scanned into the memory box are sent in response to a polling request from another fax unit.
1.ERASE AFTER TX	Determines whether the document is erased from the memory after it is sent in response to a polling request.  <b>ON</b> The document is erased after it is sent. The memory box is polled and sends the document only once.  <b>OFF</b> The document is not erased after it is sent. The memory box can be polled to send the document indefinitely.

---

## Memory Box Setup Summary (Cont'd)

2.TX DOCUMENT	This setting determines which documents to send when the memory box is polled: (1) only documents received in the memory box or (2) only documents scanned into the memory box.
1.RECEIVED DOCUMENT	<p>Determines whether to transmit the documents received in the memory box when the memory box is polled.</p> <p><b>TRANSMIT</b> When the memory box is polled, documents in the memory box received from other fax units are sent.</p> <p><b>NOT TRANSMIT</b> When the memory box is polled, documents in the memory box received from other fax units are not sent.</p>
2.SCAN DOCUMENT	<p>Determines whether to transmit the documents scanned into the memory box when the memory box is polled.</p> <p><b>TRANSMIT</b> When the memory box is polled, documents scanned into the memory box are sent.</p> <p><b>NOT TRANSMIT</b> When the memory box is polled, documents scanned into the memory box are not sent.</p>

## Changing the Memory Box Settings

Follow this procedure to change the memory box settings.

1. Open the MEMORY BOX menu. (→8-13)

```
MEMORY BOX
1.SETUP FILE
```



2. Press the search buttons to display CHANGE DATA.

```
MEMORY BOX
2.CHANGE DATA
```



3. Press SET.

```
CHANGE DATA
SET BOX #      00
```

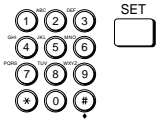

- Use the buttons on the numeric keypad to enter the number of the box you want to change and press SET.

CHANGE DATA  
PASSWORD \_

If you have not set the operation password, you can skip the next step.

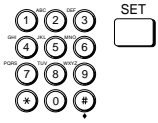

- Enter the four-digit password protecting the memory box settings and press SET.



- Press the search buttons to display the setting you want to change.

CHANGE DATA  
1.FILE NAME

CHANGE DATA  
8.POLLING TX



- With the setting you want to change on the display, press SET.
- Follow the same procedures you used to set the initial settings or change the defaults. (→8-13)



---

If you want to change the operation password, first you will have to enter the old password (it will not be displayed) and then enter the new password (it will be displayed as you enter it.)

---



- When you are finished making changes, press STOP to return to standby.



## Cancelling a Memory Box

Follow this procedure to cancel a memory box.

1. Open the MEMORY BOX menu. (→8-13)

MEMORY BOX  
1.SETUP FILE



2. Press the search buttons until you see the display below.

MEMORY BOX  
3.DELETE FILE



3. Press SET.

DELETE FILE  
SET BOX # 00

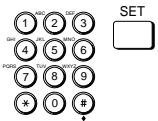

4. Enter the number of the box you want to delete and press SET.

DELETE FILE  
PASSWORD \_

If you have not set the operation password, you can skip the next step.

5. Enter the four-digit password protecting the memory box settings and press SET.

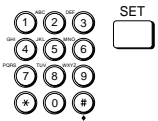

DELETE FILE  
FILE DELETED

6. Press STOP to return to standby.



## Sending a Document Stored in the Memory Box

Follow this procedure to store a document in the memory box for sending according to the memory box setup. (→8-13)

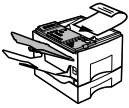

1. Set the document on the fax. (→6-3)

Set the document resolution, contrast, and document type. (→6-4)

You can also select a sender's name with the TTI SELECTOR. (→6-6)



MEMORY BOX



SET



2. Open both One-touch Speed Dialling panels. Then press MEMORY BOX.

```
MEMORY BOX
1.MEMORY BOX TX
```

3. Press SET.

```
SUBADDRESS
```

4. Use the buttons on the numeric keypad to enter the ITU-T subaddress of the memory box. Then press SET.

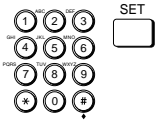

```
MEMORY BOX TX
SENDER'S NAME
```

```
SENDER'S NAME
CANON, INC.
```

5. Press TTI SELECTOR until you see the sender name you want to use. You can also use the search buttons to scroll up and down the TTI list.

TTI SELECTOR



^



v



```
SENDER'S NAME
01 R.LOUIS
```

SET



6. Press SET.

```
TRANSMIT          0037
SCANNING DOC.    P.001
```

The fax begins to scan the document.

The document is stored in the memory box and will be sent according to the memory box settings. (→8-13)

# Printing a Document Received in a Memory Box

Follow this procedure to print a document that has been received and stored in a memory box according the memory box setup. (→8-13)



You can use this procedure to print a document from the memory box only after you have set PRINT RX DOC. to ON and set PRINT METHOD to MAN. under the RECEIVE item of the memory box setup.

After the fax receives a document in a memory box, the fax displays a message and prints a report, unless this feature has been turned off. (→16-8)

PRINTING REPORT

```

26/12 '97 16:00 FAX 833 4423 WORLD ESTATE, INC. 001
* * * * *
* MEMORY BOX REPORT *
* * * * *

BOX# #66
FILE NAME R. LOUIS
TX/RX NO 5028
CONNECTION TEL 444 536
SUBADDRESS #061348
CONNECTION ID CANON, INC.
ST. TIME 26/12 11:00
USAGE T. 00'55"
PGS. 1
RESULT OK
    
```

A message will alternate with the standby display (date and time) until you print the document received in the memory box.

RECEIVED IN MEM. BOX

1. Open both One-touch Speed Dialling panels. Then press MEMORY BOX.



MEMORY BOX



MEMORY BOX  
1.MEMORY BOX TX

2. Press the search buttons until you see the display below.



MEMORY BOX  
2.MEMORY BOX RX



3. Press SET.

SUBADDRESS

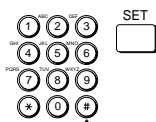

4. Use the buttons on the numeric keypad to enter the ITU-T subaddress of the memory box holding the document you want to print. Then press SET.

MEMORY BOX RX  
PASSWORD \_

If you have not set the operation password, the documents starts printing.

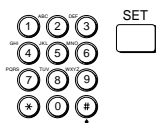

5. Enter the four-digit operation password that protects the memory box setup and press SET.

After you enter the operation password, the document starts printing.

MEMORY BOX RX  
PRINTING P.001/001

## What Happens to Memory after a Power Failure

If power to the fax is lost due to a power failure, or if the fax is accidentally unplugged, a built-in battery keeps a trickle of current supplied to the memory so all the documents currently stored in the memory can be saved for up to approximately 12 hours.

### How Your Registered Data Is Protected

This is what happens when the fax is disconnected:

- The backup battery takes over and keeps a trickle of current flowing to the memory in order to preserve all the documents in the memory waiting to be sent or printed.
- However, if the fax is left off for longer than approximately 12 hours, all documents in the fax memory will be lost after the battery runs down, and as soon as power is restored to the fax a Memory Clear List is printed that shows you what documents were erased. (→14-15)

- Because your user data and speed dialling settings are constantly refreshed by a lithium battery, they will not be lost as a result of a power failure, even if power to the fax is cut off for longer than approximately 12 hours.
- When many documents are stored in the fax memory, the fax may need about 2 minutes to recover after power is restored to the fax.

## ***About the Backup Battery***

Here is a list of things to keep in mind about the backup battery.

- The backup battery that preserves document data in the memory for up to 12 hours in case of a power loss is a rechargeable battery, and it requires about 1 day to reach full charge after power to the fax unit is restored.
- Frequently disconnecting the fax unit from the power source shortens the service life of the battery.
- To avoid shortening the backup battery service life, use the fax within a temperature range of 10°C to 32.5°C. If the fax is used in an environment that is too hot or too cold, this can shorten the service life of the backup battery.
- If the backup battery can not preserve data even after you plug in the power source and the fax is left on for 1 day (24 hours), call for service and have the backup battery replaced.



# Chapter 9

## Using a Relay Network

---

This chapter shows you how to relay documents and how to have documents relayed for you.

You can set up your fax unit as a relay station to relay documents that you receive, or you can send documents to another fax and have the documents relayed for you.

What is Relay Broadcasting? .....	9-2
Setting Up and Using a Standard Relay Unit .....	9-2
Setting Your Fax as a Relay Unit .....	9-3
Changing the Relay Broadcast Settings .....	9-6
Deleting the Relay Group .....	9-7
Sending a Document to a Relay Unit for Relay Broadcasting .....	9-8
Sending a Document to a Relay Unit with Speed Dialling .....	9-9
Sending with the RELAY BROADCAST Button .....	9-10

# What is Relay Broadcasting?

In a relay broadcast, the originator fax unit sends a document over a long distance to another fax called the relay unit. After the relay unit receives your document, it automatically sends the document to several other fax units in the local area. In this way you can send a document to several fax units in the same locality with only one long distance transmission.

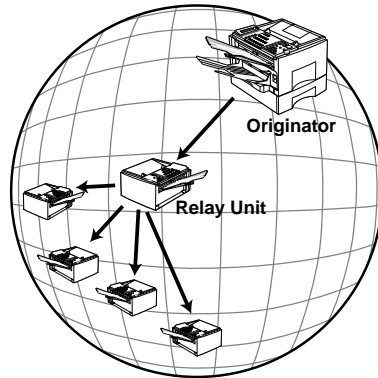

In a relay network your fax unit can function as both an originator and a relay unit. When your fax unit is the *originator*, it sends a document to a relay unit from which the document is relayed to several destination in the same locality. When your fax unit is the *relay unit* it receives a document from another party and relays it to one or several other faxes in your own locality.

## Setting Up and Using a Standard Relay Unit

In this section we will show you how to set up and manage a relay network with the standard relay features provided on the fax.

Before you set up your fax to relay documents from the originator fax unit, confirm the following points:

- Make sure your unit telephone number is correctly registered. (→3-11)
- Make sure the telephone number of the originator fax unit is registered on your fax for a speed dialling button. (→14-2)
- After your fax receives the document from the originator it will relay the document to one or several destination units. Make sure the telephone numbers of all the destination units are registered on your unit for speed dialling buttons. (→14-2)



- Ask the originator if they would like to receive a report of successful transmission after your fax relays the document.
- Make sure the relay feature on your fax is turned on.

Follow the procedures in this section to set up your fax as a relay unit. When your fax is the relay unit, it receives the document from the originator and relays it to several other destinations.

## Setting Your Fax as a Relay Unit

Follow this procedure to set your fax to participate in a relay network as a relay unit.

1. Open the RELAY TX GROUP menu.

Open both One-touch Speed Dialling panels and press DATA REGISTRATION.

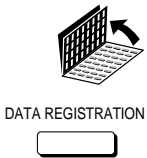

```
REGISTRATION
1.DATA REGISTRATION
```

Press SET.



```
DATA REGISTRATION
1.USER SETTINGS
```

Press the search buttons until you see the display below.



```
DATA REGISTRATION
6.FILE SETTINGS
```

Press SET.



```
FILE SETTINGS
1.CONFID. MAILBOX
```

Press the search buttons until you see the display below.



```
FILE SETTINGS
2.RELAY TX GROUP
```

Press SET.



```
RELAY TX GROUP
1.SETUP FILE
```

- Give the relay group a number from 00 to 99.



Press SET.

```

SETUP FILE
SET RLY TX GROUP# 00
  
```

Use the buttons on the numeric keypad to enter the two-digit relay group number and press SET.

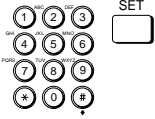

```

SETUP FILE
1.GROUP DIAL NAME
  
```

Use the search buttons to display all the items in the menu.



With the item displayed that you want to set, press SET. Then follow the instructions in the table below to set up the relay group.



When you are finished, press STOP.

### Relay Group Setup Summary

The default settings, shown in bold, remain in effect unless you change them.

1.GROUP DIAL NAME	<b>Name (24 characters)</b>
	Enter a name for the relay group. The name can be up to 24-characters long. Then press SET.
2.PASSWORD	<b>0000-9999</b>
	This is the four-digit password that protects the relay box settings you are about to set up. After you set this password, you will have to enter it every time you want to view or change these settings. Enter a four-digit password and press SET.
3.SUBADDRESS	<b>20 digits (* # spaces)</b>
	This is the ITU-T subaddress. Enter a number up to 20 digits long (it can include spaces and the symbols * and #).
4.RX PASSWORD	<b>20 digits (* # spaces)</b>
	When your fax is the relay unit, this ITU-T password must match the ITU-T password of the document sent from the originator in order for your fax to receive the document. Otherwise, your fax will not receive the document. Enter a number up to 20 digits long (it can include spaces and the symbols * and #).

## Relay Group Setup Summary (Cont'd)

---

5.SELECT ORIG UNIT	When your fax is the relay unit, this feature forces your fax to check the identity of the originator before it receives the document for relay to other units.
<b>ON</b>	When your fax receives a document for relay, it will check the identity of the originator before it receives the document. <i>In order for this feature to perform correctly, the telephone number of the originator unit must be registered correctly for speed dialling on your fax unit.</i>
TEL =	Press the One-touch Speed Dialling button or press the CODED DIAL button followed by the three-digit code where the number for the originator fax is registered and press SET.
OFF	Your fax will receive a document for relay without checking the identity of the originator.
<hr/>	
6.PRINT RX DOC.	When your fax is the relay unit, this setting determines if your fax unit prints a copy of every document that it relays.
<b>OFF</b>	Your fax does not print a copy of every document it relays to other fax units.
ON	Your fax prints a copy of every document it relays to other fax units.
<hr/>	
7.SELECT LOCATIONS	This item allows you to select the fax units to receive the document your unit relays. <i>The number of fax units to receive the document must be registered for One-touch or Coded Speed Dialling. You can not enter a number with regular dialling.</i>
TEL =	Close the One-touch Speed Dialling panels and press the speed dialling buttons where the numbers of the fax units to receive the relay broadcast are registered then press SET. You can select up to 200 destinations.
<hr/>	
8.TX REPORT	This feature determines if your fax unit returns a relay transmission report to the originator after your fax unit receives and relays a document.
<b>TRANSMIT</b>	After your fax unit relays a document, it sends a transmission report back to the originator. <i>In order for the feature to perform correctly, the originator's unit telephone number must be registered on your fax for One-touch or Coded Speed Dialling.</i>
NOT TRANSMIT	No relay transmission report is sent to the originator after a document has been relayed.

---

## Relay Group Setup Summary (Cont'd)

---

9.TX START TIME	<p>You can set your fax to hold documents and then relay them at a preset time. If you do not set this item, all documents received for relay are relayed immediately. If you want to use this feature, press SET.</p> <p>Use the buttons on the numeric keypad to enter the time in 24-hour format. You can set up to 5 times to relay documents within a 24-hour period every day.</p>
-----------------	--

---

10.RELAY B'CAST	<p>This feature switches relay broadcasting for this group on and off without altering any of the other settings.</p> <p><b>ON</b> Your fax unit receives and relay a document set for relay broadcasting.</p> <p><b>OFF</b> Your fax unit will not receive and relay a document set for relay broadcasting</p>
-----------------	---

---

## Changing the Relay Broadcast Settings

Follow this procedure to change the relay broadcast settings.

- If you want to add to the list of fax units to receive relay broadcasts from your fax unit, make sure that the numbers you want to add are registered for One-touch or Coded Speed Dialling.
- If you want to set your fax unit to confirm the identity of the originator before it receives a document for relay broadcasting, make sure the telephone number of the originator's fax unit is registered for One-touch or Coded Speed Dialling on your fax unit.

1. Open the RELAY TX GROUP menu. (→9-3)

RELAY TX GROUP  
1.SETUP FILE



2. Press the search buttons until you see the display below.

RELAY TX GROUP  
2.CHANGE DATA



3. Press SET.

CHANGE DATA  
SET RLY TX GROUP# 00

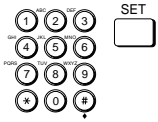

- Use the buttons on the numeric keypad to enter the group number. Then press SET.

```
CHANGE DATA
PASSWORD _
```

If you have not set the operation password, you can skip the next step.

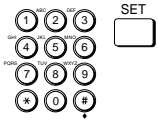

- Enter the four-digit operation password and press SET.

```
CHANGE DATA
1.GROUP DIAL NAME
```

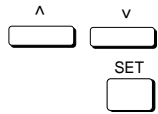

- Press the search buttons to display the item you want to change and press SET.

- To change the settings for an item, follow the same procedures you used for initial setup of the relay group. (→9-3)
- To delete an item, press CLEAR and then press SET.
- To turn off the relay feature for the group and retain the setup, press the search buttons to display 10.RELAY B'CAST, press SET, and turn this feature off. You do not have to delete the relay group to disable it temporarily.
- To change the operation password, first you have to enter the old password (it is not displayed as you enter it) and then you have to enter the new password (it is displayed as you enter it).

- When you are finished making changes, press STOP to return to standby.



## Deleting the Relay Group

Follow this procedure to delete the relay group and all of its settings.

- Open the RELAY TX GROUP menu. (→9-3)

```
RELAY TX GROUP
1.SETUP FILE
```



- Press the search buttons until you see the display below.

```
RELAY TX GROUP
3.DELETE FILE
```



Press SET.

DELETE FILE  
SET RLY TX GROUP# 00

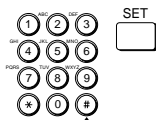

- Use the buttons on the numeric keypad to enter the relay group number then press SET.

DELETE FILE  
PASSWORD \_

If you have not set the operation password, you can skip the next step.

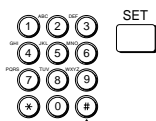

- Enter the four-digit operation password and press SET.

DELETE FILE  
FILE DELETED



- Press STOP to return to standby.

If the relay has been set for timer sending and the document is still in the memory, you will not be able to delete the relay group until the document is sent. In this case the fax will prompt:

CAN NOT DELETE

Wait until the document is sent before you attempt to delete the relay group.

## ***Sending a Document to a Relay Unit for Relay Broadcasting***

Follow this procedure to send a document to a relay unit.



---

In this procedure your fax is the originator.

---

Before you send a document to another fax for relay broadcasting, confirm the following points on your fax:

- Make sure your own fax unit telephone number are correctly registered. (→3-11)
- Enter a subaddress.

Before you send a document to another fax for relay broadcasting, contact the other party and confirm the following points about their fax:

- The relay unit must support ITU-T subaddress/password transactions.
- If you want a relay transmission report sent back to your fax from the relay unit, instruct the relay unit to turn this feature on when they set up the relay function on their fax.
- Make sure the relay unit has registered the telephone numbers of all destinations for the speed dialling buttons of the relay unit.
- Make sure you have the correct subaddress for the other party's fax.
- Confirm that the subaddress you have been given has been used to set up the other party's fax as a relay station. Your fax can not confirm whether or not the other party's fax has been set up properly as a relay unit.
- If an ITU-T password is set on the other party's fax you must send the document with a password. Otherwise, the other fax will not receive your document.

After the relay fax is set up to participate in a relay network, it should receive and relay documents automatically. By following the initial setup procedures in the previous section, the relay fax unit can be set to confirm the identity of the originator before sending and to send a relay transmission report to the originator after your fax unit requests the other unit to relay a document.



---

When your fax unit is the originator of a relay transmission with this method, it does not check to ensure that the fax to receive and relay the transmission is set up properly for relay transmission. Even when the fax is not set up to relay your documents, your fax unit reports such a transmission as a successful relay transmission. Make sure the relay unit is set up correctly to relay documents that it receives from your fax unit.

---

## ***Sending a Document to a Relay Unit with Speed Dialling***

You can register a telephone number for relay sending under a One-touch or Coded Speed Dialling button.

Check these points before you send a document to another party for relay:

- Contact the other party and ask for the ITU-T subaddress and password they are using for receiving documents to relay.
- The other party's fax unit does not have to be a Canon fax unit, but make sure the other party's fax unit supports the use of ITU-T subaddresses and passwords.

- Perform the procedure to register a telephone number for One-touch or Coded Speed Dialling. (→4-6, 4-14) If the speed dialling buttons are already set up, perform the procedure to change the One-touch or Coded Speed Dialling settings. (→4-6, 4-14)
- When you do the speed dialling settings, turn on the OPTIONAL SETTING feature and select TX TYPE. Select ORIG RELAY TX and then set the ITU-T subaddress and password. (→4-11, 4-19) Confirm that the other party is set up properly to relay documents received from your fax. Your fax can not confirm whether or not the other fax has been set up properly for relaying a document sent from your fax.

## ***Sending with the RELAY BROADCAST Button***

Follow this procedure to send the original document for a relay broadcast with the RELAY BROADCAST button.



---

You can set only one destination.

---

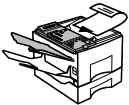

1. Set the document on the fax. (→6-3)

Set the document resolution, contrast, and document type. (→6-4)

You can also select a sender's name with the TTI SELECTOR. (→6-6)



RELAY BROADCAST



ORG RELAY TX  
 SELECT LOCATIONS

TEL=

2. Open both One-touch Speed Dialling panels and press RELAY BROADCAST.

3. Dial the relay units.

Use regular dialling. (→6-7)

-or-

Press a One-touch Speed Dialling button, or press CODED DIAL followed by a three-digit code. (→4-26, 4-28)

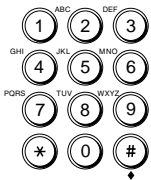



-or-

Dial the number with directory dialling. (→4-31)

TEL= 123 4567  
01 CANON, INC.

SET

Press SET.

SUBADDRESS

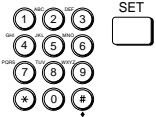

4. Enter the ITU-T subaddress required to start the relay broadcast on the other party's fax. Then press SET.

TEL= 123 4567  
01 CANON, INC.

If a password is not required go on to the next step.

-or-

PASSWORD

If an ITU-T password is also required to start the relay broadcast, press **PASSWORD**.

PASSWORD



---

You must press **PASSWORD** within 5 seconds of pressing **SET**. If you wait longer than the timeout interval before pressing **PASSWORD**, the fax will start scanning the document. The timeout interval can be turned off. (→16-11)

---

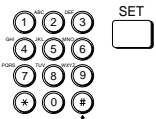

Enter the ITU-T password required to start the relay broadcast on the other party's fax. Then press SET.

TEL= 123 4567  
01 CANON, INC.

5. Press **START/SCAN** to start the transmission.

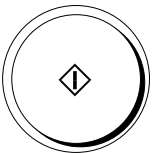



# Chapter 10

## Using Confidential Mailboxes

---

This chapter shows you how to send and receive confidential documents.

A confidential document is a document that does not print as soon as it is received. The receiving party must use a password to unlock his or her mailbox in order to print the document. Use confidential sending and receiving for documents that you want only the person with the correct password to read.



---

You can not use the conventional Canon confidential mailbox feature.

---

Setting Up and Using the Standard Mailbox Features .....	10-2
Creating a Mailbox .....	10-2
Changing Mailbox Settings .....	10-5
Cancelling a Mailbox .....	10-6
Receiving a Confidential Document .....	10-7
Sending a Confidential Document .....	10-9
Sending a Confidential Document with Speed Dialling .....	10-9
Sending a Confidential Document with the Confidential Mailbox Button .....	10-10

# Setting Up and Using the Standard Mailbox Features

In this section we will describe how to create your own mailbox, change the mailbox settings when necessary, and delete the mailbox when it is no longer needed.

## Creating a Mailbox

Follow this procedure to create a mailbox to hold confidential documents in a private mailbox protected with a password.

1. Open the CONFID. MAILBOX menu.

Open both One-touch Speed Dialling panels. Then press DATA REGISTRATION.



DATA REGISTRATION

SET

REGISTRATION  
1.DATA REGISTRATION

Press SET.

DATA REGISTRATION  
1.USER SETTINGS

Press the search buttons until you see the display below.



DATA REGISTRATION  
6.FILE SETTINGS

Press SET.

FILE SETTINGS  
1.CONFID. MAILBOX

SET

SET

Press SET.

CONFID. MAILBOX  
1.SETUP FILE

2. Give the mailbox a number.

Press SET.

SET

SETUP FILE  
SET BOX # 00

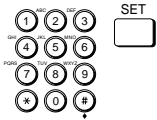

Use the buttons on the numeric keypad to enter a two-digit code for the confidential mailbox number. Then press SET.

SETUP FILE  
1. FILE NAME



Press SET.

FILE NAME :A  
\_

3. Give the mailbox a name to identify it in printed reports.

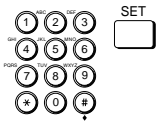

Use the buttons on the numeric keypad to enter a personal name for the mailbox. The name can be up to 24 characters long and may include numbers, symbols, and spaces. Then press SET.

SETUP FILE  
2. PASSWORD

4. Give the mailbox a password to protect the mailbox content and settings from unauthorized access.



Press SET.

PASSWORD  
\_

- This password protects the confidential mailbox settings from unauthorized access. The next time you want to open this menu to view the settings or make any changes, you will have to enter this password to open the menu.
- You will have to enter this password to print documents you receive in your mailbox. Do not forget your password.

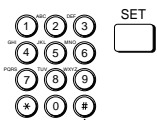

Use the buttons on the numeric keypad to enter a four-digit password. Then press SET.

SETUP FILE  
3. SUBADDRESS

- Give the mailbox an ITU-T subaddress.



Press SET.

SUBADDRESS

This item is the ITU-T standard subaddress. *This setting is required.* All confidential documents sent to you must be sent with this subaddress in order to be stored in your mailbox. If the subaddresses do not match, the document will not be received.

Use the buttons on the numeric keypad to enter an ITU-T subaddress up to 20-digits long. Then press SET.

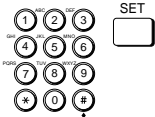

SETUP FILE  
4.RX PASSWORD



---

This next setting is optional. If you set a password, however, the confidential documents sent to you must also include this password.

---

- To enter an ITU-T password, press SET.



RX PASSWORD

Use the buttons on the numeric keypad to enter an ITU-T password up to 20-digits long. Then press SET.

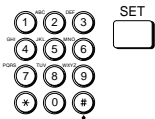

SETUP FILE  
5.# OF RX COPIES

- Normally only one copy of a document received in a confidential mailbox is printed. If you want to print more copies, change this settings. Otherwise, go on to the next step.

To specify more copies, press SET.



# OF RX COPIES  
01COPIES



Press the search buttons to increase or decrease the number.

-or-

Use the buttons on the numeric keypad to enter the two-digit code. For numbers 00 to 99 you must enter 2 digits, including the zero.



Press SET.

```
SETUP FILE
SET BOX # 00
```

- 8. You can repeat this procedure to set up another mailbox.

-or-

Press STOP to return to standby.



## Changing Mailbox Settings

Follow this procedure to change the settings for a mailbox. To open the mailbox to view and change the settings, you must know the mailbox number and password.

- 1. Open the CONFID. MAILBOX menu. (→10-2)

```
CONFID. MAILBOX
1.SETUP FILE
```



- 2. Press the search buttons until you see the display below.

```
CONFID. MAILBOX
2.CHANGE DATA
```

- 3. Open the mailbox with its number and password.



Press SET.

```
CHANGE DATA
SET BOX # 00
```

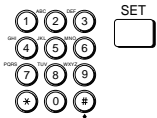

Use the buttons on the numeric keypad to enter the two-digit code of the mailbox you want to change. Then press SET.

```
CHANGE DATA
PASSWORD _
```

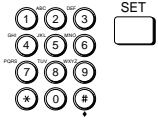

Use the buttons on the numeric keypad to enter the four-digit password protecting access to the mailbox. Then press SET.

CHANGE DATA  
1. FILE NAME



4. Press the search buttons to display the item you want to change.

CHANGE DATA  
1. FILE NAME

CHANGE DATA  
5. # OF RX COPIES



5. With the item you want to change shown in the display, press SET.

6. To change an item, follow the same procedures you used to perform the initial settings. (→10-2)

7. Press STOP to return to standby.



## Canceling a Mailbox

Follow this procedure to cancel a mailbox.

1. Open the CONFID. MAILBOX menu. (→10-2)

CONFID. MAILBOX  
1. SETUP FILE



2. Press the search buttons until you see the display below.

CONFID. MAILBOX  
3. DELETE FILE



3. Press SET.

DELETE FILE  
SET BOX #            00



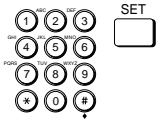

- Use the buttons on the numeric keypad to enter the number of the mailbox you want to delete. Then press SET.

```
DELETE FILE
PASSWORD _
```

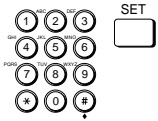

- Use the buttons on the numeric keypad to enter the four-digit password protecting the mailbox you want to delete. Then press SET.

```
DELETE FILE
FILE DELETED
```



- Press STOP to return to standby.

## Receiving a Confidential Document

When the fax receives a confidential document with a subaddress or subaddress and password that match the subaddress/password settings for your confidential mailbox, the document is stored in the mailbox.

After the fax unit receives a document in a confidential mailbox, it displays a message and prints a report.

```
PRINTING REPORT
```

```
26/12 '97 14:26 FAX 833 4423 WORLD ESTATE, INC. 001
* * * * *
* CONFID. RX REPORT *
* * * * *

CONFID.MBOX# #01
CONFID.MBOX NAME LOUIS
TX/RX NO 5028
CONNECTION TEL 444 5380
SUBADDRESS 1234
CONNECTION ID JOHN BARRISTER
ST. TIME 26/12 13:13
USAGE T 00'56
PGS. 1
RESULT OK
```

- The report lists the subaddress where the documents have been received.
- Printing this Confidential Receive Report every time you receive a confidential document can be turned off and on. (→16-8)

After the report prints, a message alternates with the standby display (date and time) until you print the report received in the mailbox.

RECEIVED IN MAILBOX

Follow this procedure to print a document received in a confidential mailbox.

1. Open both One-touch Speed Dialling panels. Then press CONFIDENTIAL MAILBOX.



CONFIDENTIAL MAILBOX



CONFID. TX/RX  
1.CONFIDENTIAL TX

2. Press the search buttons until you see the display below.

CONFID. TX/RX  
2.CONFIDENTIAL RX

3. Press SET.



SUBADDRESS

4. Use the buttons on the numeric keypad to enter the subaddress for the mailbox. Then press SET.

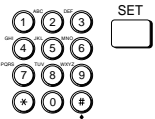

CONFIDENTIAL RX  
PASSWORD \_

5. Use the buttons on the numeric keypad to enter the four-digit password to open the mailbox. Then press SET.

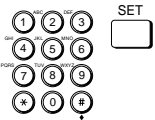

---

To protect your password, it is not displayed when you enter it.

---

The document starts printing.

CONFIDENTIAL RX  
PRINTING P.001/002

# ***Sending a Confidential Document***

Sending a document with a subaddress and password does not ensure that the document will be received as a confidential document. Before your fax sends a document, it can not confirm that the other party has their fax set up for confidential receiving.

You can use two methods to send a confidential document:

- If you frequently use the confidential sending feature, you can register a telephone number for confidential sending with One-touch or Coded Speed Dialling registration.
- You can also enter the ITU-T subaddress and password with CONFIDENTIAL MAILBOX button.

## ***Sending a Confidential Document with Speed Dialling***

You can register a telephone number for confidential sending at the touch of a One-touch Speed Dialling button or by pressing CODED DIAL followed by a three-digit code.

Check these points before you send a confidential document to another party:

- Contact the other party and ask for the ITU-T subaddress and password they are using for receiving confidential documents.
- The other party's fax unit does not have to be a Canon fax unit, but make sure the other party's fax unit supports the use of ITU-T subaddresses and passwords.
- Perform the procedure to register a telephone number for One-touch or Coded Speed Dialling. (→4-6, 4-14)
- If the speed dialling buttons are already set up, perform the procedure to change the One-touch or Coded Speed Dialling settings. (→4-6, 4-14)
- When you do the speed dialling settings, turn on the OPTIONAL SETTING feature and select TX TYPE. Select CONFIDENTIAL TX and then set the ITU-T subaddress and password. (→4-6, 4-14)
- Confirm that the other party has set up a confidential mailbox with the subaddress you have been given. *Your fax can not confirm whether or not the subaddress has been used to set up a confidential mailbox.*

# Sending a Confidential Document with the Confidential Mailbox Button

Note these points about sending a confidential document to a confidential mailbox.

- You can dial only one telephone number.
- If you frequently need to send a confidential document to more than one location, register the number, subaddress, and password for One-touch or Coded Speed Dialling so you can use multiple broadcasting. (→4-6, 4-14)
- If you use One-touch or Coded Speed Dialling to dial the number after you perform the following operation, the transmission mode settings registered for the speed dialling button are ignored.
- The password setting is optional but required if the other party has set a password on the other fax unit.

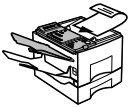

1. Set the document on the fax. (→6-3)

Set the document resolution, contrast, and document type. (→6-4)

You can also select a sender's name with the TTI SELECTOR. (→6-6)



CONFIDENTIAL MAILBOX



SET



2. Open both One-touch Speed Dialling panels and press CONFIDENTIAL MAILBOX.

CONFID. TX/RX  
1.CONFIDENTIAL TX

3. Press SET.

CONFIDENTIAL TX  
SELECT LOCATIONS

TEL=

4. Use the buttons on the numeric keypad to dial the number. (→6-7)

-or-

Close the One-touch Speed Dialling panels and press a One-touch Speed dialling button to dial the number, or press CODED DIAL and enter the three-digit code. (→4-26, 4-28)

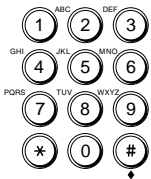

-or-

Dial the number with directory dialling. (→4-31)

- You can dial only one number.
- The transmission mode settings for the speed dialling button are ignored.

Press SET.



SUBADDRESS

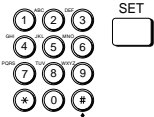

5. Use the buttons on the numeric keypad to enter the ITU-T subaddress. Then press SET.

TEL= 123 4567  
CANON, INC.



6. If you must also enter an ITU-T password, press PASSWORD. Otherwise, just go on to the next step.

PASSWORD



---

You must press **PASSWORD** within 5 seconds of pressing **SET**. If you wait longer than the timeout interval before pressing **PASSWORD**, the fax will start scanning the document. The timeout interval can be turned off. (→16-11)

---

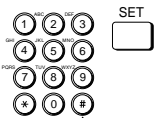

Use the buttons on the numeric keypad to enter the ITU-T password. Then press SET.

TEL= 123 4567  
01 CANON, INC.

7. Press **START/SCAN** to start the transmission.

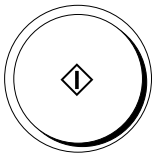



# Chapter 11

## Setting Up and Using Polling

---

This chapter shows you how to set up and use polling sending and receiving. Polling is useful when one or both parties can not be in the office at the same time.

What's Polling? .....	11-2
Before You Use Polling Receiving .....	11-2
Polling Other Fax Machines to Receive a Document .....	11-3
Polling to Receive at a Preset Time .....	11-5
Changing the Preset Polling Settings .....	11-11
Cancelling Preset Polling .....	11-12
Setting Up Polling Sending .....	11-13
Before You Can Be Polled to Send .....	11-13
Setting Up a Polling Box .....	11-13
Scanning a Document into the Memory for Polling Sending .....	11-17
Changing the Polling Box Setup .....	11-19
Cancelling a Polling Box .....	11-20

# What's Polling?

Polling means a fax calls another fax and requests that the other fax send a document that it is holding. Unlike normal sending and receiving, in polling the receiver always calls the sender. This is called polling to receive a document. The sender sends the document in response to the polling by a telephone call from the receiver.



---

Your fax can be set up to function in both roles. Your fax can poll to receive a document, or it can be polled to send a document that it is holding.

---

## Before You Use Polling Receiving

Before you try to set up polling, note the following points:

- With one operation you can poll several faxes. You can dial up to 210 telephone numbers and poll those faxes to receive documents that they are holding.
- You can poll a document at any time, but you may find it more useful to set your fax for polling other faxes at specified times throughout the day. (→11-5)
- You must know if the other fax is holding the document under both a subaddress and password or only a subaddress or password. You must also know the subaddress and password so you can enter them on your fax. If you do not know the subaddress or password, contact the other party.
- If the other party's document(s) are registered for polling without a subaddress or password, you can still perform polling receiving.
- If the other party's fax does not support ITU-T subaddress/password transactions, you can ask them to set the polling ID to 255 or 1111 1111 binary when the other party's fax machine is a Canon fax.



# Polling Other Fax Machines to Receive a Document

Follow this procedure to poll another fax to receive the document that it is holding. This procedure starts polling the other fax immediately. You can also set the fax to poll at a preset time. (→11-5)



POLLING



1. Open both One-touch Speed Dialling panels. Then press POLLING.

POLLING  
 1.POLLING TX

2. Press the search buttons until you see the display below.

POLLING  
 2.POLLING RX

SET

3. Press SET.

TEL=

TTI SELECTOR



You can select a sender's name with the TTI SELECTOR. (→6-6)



4. Close both One-touch Speed Dialling panels and dial the other party's number.

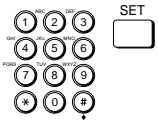

Use the buttons on the numeric keypad to dial the number. If you use regular dialling, make sure you press SET after you dial the number. (→6-7)

-or-

Press a One-touch Speed Dialling button to dial the number. (→4-26)

-or-

Press CODED DIAL and a three-digit code to dial the number. (→4-28)

-or-

Dial the number with directory dialling. (→4-31)

If you make a mistake during dialling, press STOP to return to standby and start again.

If you want to receive a document from a fax unit that does not support ITU-T subaddress/password transactions, press START/SCAN.

-or-

If you want to receive a document from a fax unit that supports ITU-T transactions, press SET. Then press the SUBADDRESS button.

SUBADDRESS



---

You must press SUBADDRESS within 5 seconds of pressing SET. If you wait longer than the timeout interval before pressing SUBADDRESS, the fax will start scanning the document. The timeout interval can be turned off. (→16-11)

---

An ITU-T subaddress is a number up to 20 digits long which can include spaces and the symbols \* and #.

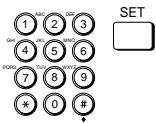

5. Use the buttons on the numeric keypad to enter the ITU-T subaddress. Then press SET.

TEL=           123 4567  
01 CANON, INC.

PASSWORD

6. If you must also enter an ITU-T password, press the PASSWORD button. Otherwise, go on to the next step.

PASSWORD



---

You must press PASSWORD within 5 seconds of SET. If you wait longer than the timeout interval before pressing PASSWORD, the fax will start scanning the document. The timeout interval can be turned off. (→16-11)

---

An ITU-T password is a number up to 20 digits long which can include spaces and the symbols \* and #.

Use the buttons on the numeric keypad to enter the ITU-T password. Then press SET.

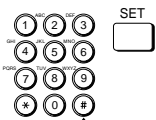

TEL=           123 4567  
01 CANON, INC.

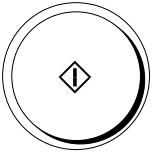

7. Press START/SCAN to start polling the other faxes.
  - If the other document is holding the document under a subaddress, your subaddress must match the other party's subaddress.
  - If the other document is holding the document under *both* a subaddress and password, then you must poll the fax with *both* a matching subaddress and password.

## Polling to Receive at a Preset Time

Follow this procedure to set the fax to poll another fax at a preset time. Polling faxes at preset times allows you to conduct document transactions later at night when the telephone rates are lower.

Before you set up polling at a preset time, make sure you have performed the following tasks:

- The numbers you want to register for dialling must be registered for One-touch or Coded Speed Dialling buttons. (→4-6, 4-14)
- When you register the One-touch or Coded Speed dialling button, you must turn on OPTIONAL SETTINGS and set the TX TYPE for POLLING RX when the other party set subaddress/password, you have to register an ITU-T subaddress and/or password for the speed dialling button. (→4-8, 4-16)
- If you have to poll a number that you use regularly, you should register it once again for another speed dialling button so you can set the ITU-T subaddress and/or password to match the polling box of the other party's fax and register the second number for preset polling.

1. Open the PRESET POLLING menu.

Open both One-touch Speed Dialling panels. Then press DATA REGISTRATION.



DATA REGISTRATION



SET



REGISTRATION  
1.DATA REGISTRATION

Press SET.

DATA REGISTRATION  
1.USER SETTINGS

Press the search buttons until you see the display below.



DATA REGISTRATION  
6.FILE SETTINGS

SET

Press SET.

FILE SETTINGS  
1.CONFID. MAILBOX

^ v

Press the search buttons until you see the display below.

FILE SETTINGS  
4.PRESET POLLING

SET

Press SET.

PRESET POLLING  
1.SETUP FILE

SET

2. Press SET.

SETUP FILE  
SET BOX # 00

SET

3. Enter a two-digit box number (00-99) for the polling box. Then press SET.

SETUP FILE  
1.FILE NAME

4. Enter a file name.

SET

Press SET.

FILE NAME :A  
\_

This is the name of the file that will hold the polled document you receive.

Use the buttons on the numeric keypad to enter a name up to 24 characters long. (→3-8)



Press SET.

SETUP FILE  
2.PASSWORD

5. If you want to set a password go to the next step.

This is the operation password to protect your preset polling settings. To change the settings later, you will have to enter this password.

-or-

If you do not want to set a password, press the down search button to display the next item.



6. Press SET to set a password.

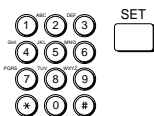

Enter a four-digit password and press SET.

SETUP FILE  
3.SELECT LOCATIONS



Press SET.

TEL=

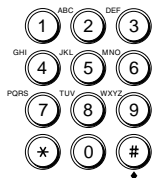

7. Dial the other party's fax number.

Press a One-touch Speed Dialling button to dial the number. (→4-26)

-or-

Press CODED DIAL and a three-digit code to dial the number. (→4-28)

If you make a mistake during dialling, press STOP to return to standby and start again.



You can enter up 200 numbers to be polled by your fax.



Press SET.

SETUP FILE  
4.START TIME

You can set the fax to poll other faxes everyday or only for selected days. For any day you can set up to 5 times for the fax to poll another unit during a 24-hour period.

- Set the fax to poll other faxes every day or on selected days.

**To set preset polling for every day**

SETUP FILE  
4.START TIME

SET

Press SET.

START TIME  
EVERYDAY

SET

Press SET.

EVERYDAY  
1: :

SET

Press SET.

EVERYDAY  
1: \_ :



Use the buttons on the numeric keypad to enter the time.

Enter the time in the 24-hour format (e.g. 1:00 p.m. as 13:00).

- If you make a mistake, press CLEAR to erase the number and try again.

EVERYDAY  
1: 00:30

SET

Press SET.

^  v

If you want to set more than one time for your fax unit to poll the other faxes, press the search buttons to display another empty setting.

EVERYDAY  
2: :



Press SET and use the numeric keypad to enter another time in 24-hour format.



You can register up to 5 times for your fax to poll other faxes every day.



When you are finished setting times, press STOP to return to standby.

### To set preset polling for selected days

SETUP FILE  
4.START TIME



Press SET.

START TIME  
EVERYDAY



Press the search buttons until you see the display below.

START TIME  
SELECT DAYS



Press SET.

SELECT DAYS  
1.SUN



Press the search buttons to display the name of the first day you want to set up then press SET.



MON  
1: :



Press SET.

MON  
1: \_ :

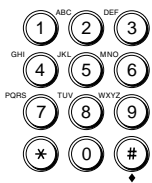

Use the buttons on the numeric keypad to enter the time.

Enter the time in the 24-hour format (e.g. 1:00 p.m. as 13:00).

- If you make a mistake, press CLEAR to erase the number and try again.

MON  
1: 02:00

Press SET.



If you want to set more than one time for your fax unit to poll the other faxes on the selected day, press the search buttons to display another empty setting.



MON  
2: :

Press SET and use the numeric keypad to enter another time in 24- hour format.



---

You can register up to 5 times for your fax to poll other faxes on the selected day.

---



When you are finished setting the time(s) for the selected day, press STOP to return to standby.

-or-

If you want to select another day, press DATA REGISTRATION to return to the previous level so you can select another day and repeat the procedure to set the times for that day.



DATA REGISTRATION



When you are finished selecting days and setting times, press STOP to return to standby.





## Changing the Preset Polling Settings

Follow this procedure to change the settings of the preset polling setup file.

1. Open the PRESET POLLING menu. (→11-11)

```
PRESET POLLING
1.SETUP FILE
```



2. Press the search buttons until you see the display below.

```
PRESET POLLING
2.CHANGE DATA
```



3. Press SET.

```
CHANGE DATA
SET BOX #      00
```

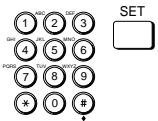

4. Use the buttons on the numeric keypad to enter the two-digit number of the preset polling box you want to change. Then press SET.

```
CHANGE DATA
PASSWORD      _
```

If you have not set the operation password, you can skip the next step.

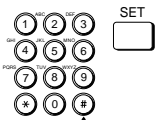

5. Use the buttons on the numeric keypad to enter the four-digit password and press SET.

```
CHANGE DATA
1.FILE NAME
```

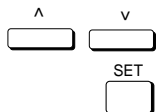

6. Use the search buttons to display the item you want to change and press SET.

```
CHANGE DATA
1.FILE NAME
```

```
CHANGE DATA
4.START TIME
```

7. To change a setting, follow the same procedures you used to set them. (→11-7)
  - To change the password setting, you will first have to enter the current password and press SET. Then you can enter a new password and press SET.
8. When you are finished making changes, press STOP to return to standby.



## Canceling Preset Polling

Follow this procedure to cancel preset polling.

1. Open the PRESET POLLING menu. (→11-5)

```
PRESET POLLING
1.SETUP FILE
```



2. Press the search buttons until you see the display below.

```
PRESET POLLING
3.DELETE FILE
```



3. Press SET.

```
DELETE FILE
SET BOX # 00
```

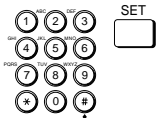

4. Use the buttons on the numeric keypad to enter the preset two-digit code of the polling box. Then press SET.

```
DELETE FILE
PASSWORD _
```

If you have not set the operation password, you can skip the next step.

5. Use the buttons on the numeric keypad to enter the four-digit password protecting the preset polling setup file. Then press SET.

After you enter the password, the file is deleted.

```
DELETE FILE
FILE DELETED
```

```
DELETE FILE
SET BOX # 00
```



6. Press STOP to return to standby.

## Setting Up Polling Sending

This section shows you how to set up your fax to store and hold a document until it is polled by another fax to send it.

### Before You Can Be Polled to Send

Before you set up your polling box, contact the parties who are going to poll your fax to receive documents and confirm the following points:

- The other parties must know your ITU-T subaddress number.
- If you are also using an ITU-T password for the polling box, they must also know this password. This password setting is optional.
- Your TX PASSWORD must match the ITU-T password attached when the other party calls you. Confirm that the TX PASSWORD on your fax matches the ITU-T password attached when the other party calls you.
- If the other party's fax does not support ITU-T subaddress/password transactions, you may be able to use the polling box #00.

### Setting Up a Polling Box

Before you can use polling sending, you must create a polling box with the File settings. The polling box holds the document in the memory until the other party polls your fax to send the document.

1. Open the FILE SETTINGS menu.

Open both One-touch Speed Dialling panels. Then press DATA REGISTRATION.



```
REGISTRATION
1.DATA REGISTRATION
```

Press SET.

```
DATA REGISTRATION
1.USER SETTINGS
```



Press the search buttons until you see the display below.

DATA REGISTRATION  
6.FILE SETTINGS



Press SET.

FILE SETTINGS  
1.CONFID. MAILBOX

2. Open the POLLING BOX menu.



Press the search buttons until you see the display below.

FILE SETTINGS  
5.POLLING BOX



Press SET.

POLLING BOX  
1.SETUP FILE

3. Create a polling box and give it a number.



Press SET.

SETUP FILE  
SET BOX # 00

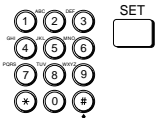

Use the buttons on the numeric keypad to enter a two-digit code for the box. Then press SET.

SETUP FILE  
1.FILE NAME



---

If the other party's fax does not support ITU-T subaddress/password transactions, set the box number to 00 so the other party can poll your fax unit and receive the document.

---

4. Create a file name to store the document in the memory where it will wait to be polled by other fax unites.



Press SET.

FILE NAME :A  
\_



Use the buttons on the numeric keypad to enter a name of up to 24 characters. (→3-7)

FILE NAME :A  
CANON TOKYO



Press SET.

SETUP FILE  
2.PASSWORD



5. If you don't want to set password, press the search buttons to go to the next step.

-or-

If you want to enter a password to protect the polling box setup file, Press SET.



PASSWORD

Use the buttons on the numeric keypad to enter a four-digit password.



PASSWORD 1147



Press SET.

SETUP FILE  
3.SUBADDRESS



---

If you set the box number to 00 for a party whose fax unit does not support ITU-T subaddress/password transactions, you do not have to register 3.SUBADDRESS and 4.TX PASSWORD. Just press the search buttons to display 5.ERASE AFTER TX then go to step 9.

---



6. Press SET.

SUBADDRESS

This is the ITU-T subaddress. An ITU-T subaddress is a number up to 20 digits long which can include spaces and the symbols \* and #.

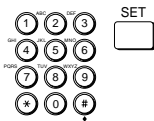

7. Use the buttons on the numeric keypad to enter the subaddress and press SET.

SETUP FILE  
4.TX PASSWORD

If you do not want to enter the ITU-T password, press the down search button to display the next item and go on to the next step.

-or-



If you want to enter an ITU-T password press SET.

TX PASSWORD

An ITU-T password is a number up to 20 digits long which can include spaces and the symbols \* and #.



If you register a TX PASSWORD, it must match the ITU-T password attached when the other party calls you.

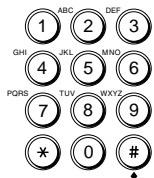

8. Use the buttons on the numeric keypad to enter the password.

TX PASSWORD  
#12345676



Press SET.

SETUP FILE  
5.ERASE AFTER TX

9. Set the polling box to erase or keep the document after polling.

Press SET.

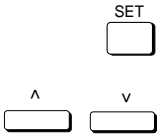

Press the search buttons to display the setting you want.



- ON The document in the memory box is erased after it is sent once in response to polling by another fax.
- OFF The document in the memory box is not erased after it is polled. Select this setting if you expect the document will be polled by more than one fax.

With the selection you want displayed, press SET.



10. You can repeat this procedure to set up another polling box.

-or-

Press STOP to return to standby.



## Scanning a Document into the Memory for Polling Sending

Follow this procedure to scan a document into the polling box. The document will remain in the polling box to be polled by other fax units.

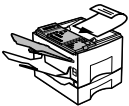

- Set the document on the fax. (→6-3)  
Set the document resolution, contrast, and document type. (→6-4)  
You can select a sender's name with the TTI SELECTOR. (→6-6)
- Open both One-touch Speed Dialling panels. Then press POLLING.





3. Press SET.

SUBADDRESS

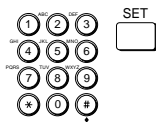

4. If the other party's fax supports ITU-T subaddresses and passwords, use the buttons on the numeric keypad to enter the subaddress for the polling box. Then press SET.

-or-



If the other party's fax does not support ITU-T subaddresses and passwords, just press SET.

5. If you want to skip selecting a sender name, go on to the next step.

-or-

TTI SELECTOR



If you want to select a sender name, press TTI SELECTOR until you see the sender name you want to use. You can also use the search buttons to scroll up and down the TTI list.



SENDER'S NAME  
20 CANON FAX DIV.



6. Press SET. The fax starts scanning the document into the polling box.

POLLING TX 6048  
SCANNING DOC. P.003

When another party polls your fax to receive a document stored in your polling box, the document is sent if the following conditions are met:

- If you entered both a subaddress and password when you created the polling box, the subaddress and password of the other party's polling request must match the subaddress and password for the polling box.
- The password setting is optional. However, if you have registered a password for the polling box, the other party's polling request must contain a matching password.
- If no password is registered for the document in the polling box and the other party's polling request contains a password, then the document is not sent.



## Changing the Polling Box Setup

Follow this procedure to change the setup of the polling box.

1. Open the POLLING BOX menu. (→11-13)

```
POLLING BOX
1.SETUP FILE
```



2. Press the search buttons until you see the display below.

```
POLLING BOX
2.CHANGE DATA
```



3. Press SET.

```
CHANGE DATA
SET BOX #      00
```

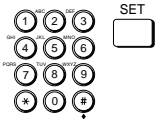

4. Use the buttons on the numeric keypad to enter the polling box number. Then press SET.

```
CHANGE DATA
PASSWORD      _
```

If you have not set the operation password, you can skip the next step.

5. Use the buttons on the numeric keypad to enter the four-digit password protecting the polling box setup file. Then press SET.

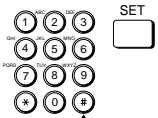

```
CHANGE DATA
1.FILE NAME
```



6. Press the search buttons to display the item you want to change.

```
CHANGE DATA
1.FILE NAME
```

```
CHANGE DATA
5.ERASE AFTER TX
```



7. Press SET.

8. To change the settings, follow the same procedures you used to set up the polling box setup file. (→11-13)



- When you are finished, press STOP to return to standby.

## Canceling a Polling Box

Follow this procedure to cancel a polling box.



---

You can not cancel a polling box when the polling box is holding a document for polling sending.

---

- Open the POLLING BOX menu. (→11-13)

```
POLLING BOX
1.SETUP FILE
```



- Press the search buttons until you see the display below.

```
POLLING BOX
3.DELETE FILE
```



- Press SET.

```
DELETE FILE
SET BOX # 00
```

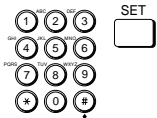

- Use the buttons on the numeric keypad to enter the number of the box that you want to delete. Then press SET.

```
DELETE FILE
PASSWORD _
```

If you have not set the operation password, you can skip the next step.

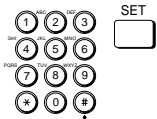

- Use the buttons on the numeric keypad to enter the four-digit operation password protecting the polling box setup file. Then press SET.

After you press SET, the polling box is deleted.

```
DELETE FILE
FILE DELETED
```



- Press STOP to return to standby.

# Chapter 12

## Other Special Features

---

This chapter describes some convenient features that you may want to use in daily operations.

Using the Telephone .....	12-2
Tone Dialling on a Pulse Line .....	12-3
Setting and Using the Program Button .....	12-4
Setting Up and Using the Optional Stamp Feature .....	12-7
Setting Up the Stamp Feature .....	12-7
Turning the Stamp Feature ON/OFF .....	12-9
How the Fax Operates with Default Settings .....	12-10

# Using the Telephone

Follow this procedure to use the telephone for voice communication if you have installed the optional handset kit. (→2-22)

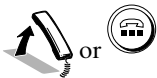

1. Pick up the handset.

-or-

Press the HOOK button.

TEL=

2. When you hear the dial tone, dial the telephone number.

Use the buttons on the numeric keypad to dial the number. (→6-7)

-or-

Press a One-touch Speed Dialling button to dial the number. (→4-26)

-or-

Press CODED DIAL and a three-digit code to dial the number. (→4-28)

-or-

Dial the number with directory dialling. (→4-31)

If you make a mistake during dialling, press STOP to return to standby and start again.

TEL= 123 4567

3. When the other party answers your call, you can talk into the handset.

-or-

If you did not pick up handset in step 1, pick up the handset as soon as you hear the other party answer. The other party will not be able to hear you until you pick up the handset.

-or-

If the other party does not answer, or if the line is busy, just hang up the handset or press HOOK to disconnect.



# Tone Dialling on a Pulse Line

Many telephone information services for banks, airline reservations, hotel reservations, etc., require tone dialling for their services. If your fax is connected to a rotary pulse line, follow this procedure to set the fax temporarily for tone dialling.



1. Press HOOK.

The IN USE lamp lights and you will hear the dial tone.

-or-

Just pick up the handset if you have installed the optional handset kit.  
(→2-20)



---

The level of the dial tone can be adjusted. (→2-12)

---

TEL=

2. Dial the telephone number.

Use the buttons on the numeric keypad to dial the telephone number of the information service.



TEL= 123 4567



TONE/+

3. When the recorded message of the information service answers, open both One-touch Speed Dialling panels, then press TONE/+.

After you press TONE/+ you will see a “T” in the display.

TEL= 123 4567T



4. Use the buttons on the numeric keypad to enter the numbers requested by the information service.

# Setting and Using the Program Button

The program button feature allows you to register a setting so you can automatically perform a routine procedure with a single button press.



DATA REGISTRATION



SET



SET



1. Open both One-touch Speed Dialling panels. Then press DATA REGISTRATION.

REGISTRATION  
1.DATA REGISTRATION

2. Press SET twice.

DATA REGISTRATION  
1.USER SETTINGS

USER SETTINGS  
1.DATE & TIME

3. Press the search buttons until you see the display below.



USER SETTINGS  
8.PROGRAM KEY

4. Press SET to display the current settings.



PROGRAM KEY  
PRINT REPORT

5. Press the search buttons to display the function you want to assign to the PROGRAM button.



---

You can select only one function at a time to assign to the PROGRAM button.

---

### **PROGRAM button Setup Summary**

The default (PRINT REPORT) remains in effect unless you change it.

---

<b>PRINT REPORT</b>	Sets the PROGRAM button to function as a print transmission report button. Whenever you need a transmission report for a document you are sending, just press the PROGRAM button and a transmission report will print after the document is sent.
REPORT	Assigns the PROGRAM button the functions of the REPORT button. Whenever you need to print a report, all you have to do is press the PROGRAM button. This saves you the effort of opening both One-touch Speed Dialling panels to press the REPORT button.
D.T.	Sets the PROGRAM button to function like the D.T. button so you do not have to open both One-touch Speed Dialling panels to press the D.T. button.
TONE	Sets the PROGRAM button to function like TONE button so you do not have to open both One-touch Speed Dialling panels to press the TONE button.
SCANNING MODE	Set up the RESOLUTION, CONTRAST, or DOCUMENT TYPE buttons for sending special documents and then store the settings under the PROGRAM button. The next time you need to set them before a document transmission, you can set them with a single button press.
STAMP	If you had the optional stamp feature installed for you, this feature is available. If you select STAMP you can turn the stamp feature on and off without opening both One-touch Speed Dialling panels to press the STAMP button.

---



### To set transmission report feature

Press the search buttons until you see the display below.

PROGRAM KEY  
PRINT REPORT



Press SET.

To use this feature, press the PROGRAM button before you dial to have a report printed for the transaction.



### To set up the REPORT button feature

Press the search buttons until you see the display below.

PROGRAM KEY  
REPORT



Press SET.

Now any time you need a report, press the PROGRAM button.



Use the search buttons to choose the report you want. Then press SET.

REPORT  
1.ACTIVITY REPORT



REPORT  
6.RX MEM. BOX LIST

### To set up the scanning mode

Press search buttons until you see the display below.



PROGRAM KEY  
SCANNING MODE



Press SET.

SELECT SCANNING MODE

Use the RESOLUTION, CONTRAST, or DOCUMENT TYPE buttons to set these features for scanning (or copying) the document. (→6-4)





Press SET.

SELECT SCANNING MODE  
DATA ENTRY OK



6. Press STOP to return to standby.

## Setting Up and Using the Optional Stamp Feature

If the optional stamp feature is provided on your fax machine, you can set the fax to stamp the front, lower left corner of every page you scan for sending.

### Setting Up the Stamp Feature



1. Open both One-touch Speed Dialling panels.

2. Open the TX SETTINGS menu.

DATA REGISTRATION



Press DATA REGISTRATION

REGISTRATION  
1.DATA REGISTRATION



Press SET.

DATA REGISTRATION  
1.USER SETTINGS



Press the search buttons until you see the display below.

DATA REGISTRATION  
3.TX SETTINGS



Press SET.

TX SETTINGS  
1.ECM TX



3. Press the search buttons until you see the display below.



This item will not appear on the menu unless your fax machine has been provided with the stamp option.



4. Press SET.

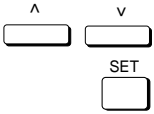

5. Press the search buttons to display ON or OFF then press SET.

If you turn this feature ON, select one of the options described on the next page.



6. When you are finished, press STOP to return to standby.

### TX Stamp Setup Summary

The default settings, shown in bold, remain in effect unless you change them.

**ON** Turns on the stamp feature. After you set this switch ON, documents will be stamped according to the following settings. If you do not want to stamp temporarily, you can use the STAMP button to turn the stamp feature off.

#### STAMP ACTION

**DIRECT & MEMORY TX** Stamps all documents you scan for direct sending or memory sending.

**DIRECT TX** Stamps only documents you scan for direct sending.

**OFF** Turns off stamping documents scanned for sending. However, before you scan a document, you can still turn on the stamp feature for a document you want to stamp with STAMP button.

# Turning the Stamp Feature ON/OFF

If you have turned the TX STAMP setting ON, documents will be stamped according to the above setting. If you have not turned on the TX STAMP feature but you still want to occasionally stamp documents you scan for sending, or if you have turned on the TX STAMP feature but you want to turn it off occasionally, follow the procedure below.

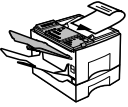

1. Set the document on the fax. (→6-3)

Set the document resolution, contrast, and document type. (→6-4)

You can also select a sender's name with the TTI SELECTOR button. (→6-6)



STAMP  
(OPTION)



2. Open both One-touch Speed Dialling panels and press STAMP.

TX STAMP OFF

3. If you want to stamp document pages, press the search buttons until you see ON.

TX STAMP ON

-or-



If you want to turn the stamp feature off, press the search buttons until you see OFF.

TX STAMP OFF

SET

4. Press SET.

TEL=



5. Close both One-touch Speed Dialling panels and send the document.

# How the Fax Operates with Default Settings

There are many minor features that you can change to customize the operation of the fax. Some of these features are listed in the table below. The description in the third column is the default setting. In other words, this is how the fax will operate unless you change the referenced setting.

If your fax is not operating as described, this means the default may have already been changed. In such a case you may want to go to the referenced page to restore the default setting.

Feature	Menu Item	Description of default
Batch sending	BATCH TX	If several documents for the same destination with the same telephone number are stored in the memory for delayed sending, when the timer goes off for one of the documents all other documents for the same destination are sent together in the same transmission, regardless of their time setting. (→16-10)
Button press sound	VOLUME CONTROL KEYPAD VOLUME	Every time you press a button on the numeric keypad you will hear a beep. The volume of this beep can be adjusted or it can be turned off. (→16-6)
Date format	DATE SETUP	In the standby mode, the date is listed in the format DD/MM 'YY. Two other formats are available. (→16-25)
Dialling timeout	TIME OUT	The fax automatically pauses five seconds after you press a speed dialling button to allow you to dial other numbers for sequential broadcasting. You can turn the timeout feature off. (→16-11)
Document smaller than paper	SELECT CASSETTE CASSETTE SW B	If you receive a letter-size document and only a larger paper size is available, the fax prints the document on the larger paper. If you do not want the smaller documents printed on larger paper, you can receive them in the memory. This switch is effective only when the letter size paper runs out. (→16-15)
Document too large for paper	SELECT CASSETTE CASSETTE SW A	If you receive a legal-size document and only letter-size paper is available, the document will be divided over two pages or reduced. If you do not want to divide documents, you can receive them in the memory. This switch is effective only when the side cassette is set to legal size and out of legal size paper. (→16-15)
ECM sending/receiving	ECM TX ECM RX	The fax is set to conduct all transactions using ECM (error correction mode). If transmission speed appears to be extremely slow, you may be able to speed up transmission time by turning ECM off. (→16-9, 16-13)
Energy Saver	ENERGY SAVER	The Energy Saver feature is off and will remain off until you turn it on. (→3-19, 16-26)
Language	DISPLAY LANGUAGE	The initial display language is English. Other languages are available. (→16-26)

<b>Feature</b>	<b>Menu Item</b>	<b>Description of default</b>
Manual receiving with extension phone	REMOTE RX	To start receiving a fax manually by answering an extension telephone connected to the fax, dial 25. You can change this number or set the fax to start receiving after hanging up the handset of the extension phone. (→7-6, 16-12)
Memory receiving	MEMORY RX	If paper or toner runs out while you are receiving a long document the remainder of the document will be stored in the memory until you can re-fill the paper cassette or replace the toner cartridge. You can also set an alarm to sound when the fax starts receiving a document in the memory. (→16-13)
Offhook alarm	OFFHOOK ALARM	If the handset remains off the hook, an alarm will sound. The volume of this alarm can be adjusted or it can be turned off. (→16-9)
Pause length	MID PAUSE SET	A pause entered within a number is set for 2 seconds. You can lengthen this pause up to 15 seconds. A pause entered at the end of a number is fixed at 10 seconds and can not be adjusted. (→4-2, 16-9)
Printing: Continue printing with toner supply low	TONER SUPPLY LOW	When the toner supply runs low, the fax saves the remainder of the document into the memory. You can set the fax to continue printing even after the toner runs low during printing. (→16-16)
Printing: Footer on printed documents	RX PAGE FOOTER	The fax will not print a footer on every document received unless you turn this feature on. (→16-13)
Printing: Print order	PRINT IN ORDER	The fax prints all document pages in reverse order when you remove them from the output tray. You can set the fax to print all document pages in the order they were sent. (→16-16)
PROGRAM button	PROGRAM KEY	If you press PROGRAM before you start a transmission, you can tell the fax to print an activity report for the transmission. This button can be programmed for other functions. (→12-4, 16-5)
Quick-on-line TX	QUICK ON-LINE TX	When you are scanning documents, the fax will start dialling and sending before all pages are scanned. You can turn this feature off. (→16-10)
Receiving password	RX PASSWORD	No receiving password is set until you set one. If the other party regularly sends you documents with only an ITU-T password with no subaddress, set the RX PASSWORD. (→16-26)
Redialling	AUTO REDIAL	If the other party's line is busy, the fax is set to perform two re-dialling attempts at two minute intervals. You can increase the number of re-dial attempts and the length of the interval between attempts. If an error occurs during re-dialling, the fax is set to re-send the first page of the document and the error page. (→6-16, 16-10)

<b>Feature</b>	<b>Menu Item</b>	<b>Description of default</b>
Reduction of document image	RX REDUCTION	All documents are automatically reduced to fit on a sheet of paper. You can also set the reduction rate to a fixed rate. You can select one of the fixed rates to increase the amount of reduction, or you can turn reduction off. (→16-15)
Report: Activity Management Report	ACTIVITY REPORT	An Activity Management Report prints after every 40 transactions. Transactions are listed in chronological order. You can turn this feature off or set the fax to print an Activity Management Report at the same time every day. You can also change the format of the report by listing sending and receiving transactions separately. (→16-8)
Report: Confidential receiving	CONFID. RX REPORT	A report is printed every time you receive a document in a confidential mailbox. You can turn this feature off. (→16-8)
Report: Error	TX REPORT REPORT WITH TX IMAGE	If an error occurs while you are sending a document, an Error TX report is printed automatically. (→16-7)
Report: Memory box receiving	MEMORY BOX REPORT	A report is printed every time you receive a document in a memory box. This feature can be turned off. (→16-8)
Report: Paper supply for printed reports	PRINT REPORT WHERE	The default setting is off (no paper cassette selected). You can select the front or lower cassette (if you install the optional cassette), or the side cassette, for the print report paper supply. (→16-8)
Report: Receiving	RX REPORT	A report is not printed when you receive a fax. However, you can set the fax to print a report every time you receive a document or if an error occurs during reception. (→16-7)
Restricting use: DACs, user access codes	RESTRICTIVE CODES	No password or access codes are set on the fax to restrict sending documents, printing, or using the handset to make a telephone call. All these functions can be restricted. (→13-5, 16-24)
Restricting use: Stopping junk mail	RX RESTRICTION	The fax is set to receive all incoming documents. You can restrict receiving to only numbers registered on your fax for speed dialling. (→13-14, 16-25)
Speed	TX START SPEED RX START SPEED	The starting speed for all transactions is set for 14400 bps. Slower settings are available. (→16-26)
Stamp	TX STAMP	If you have the optional stamp feature on your fax machine, you can turn the stamp feature on with this switch. The default setting is off. (→12-7, 16-11)
Tel/Fax switching	MAN/AUTO SWITCH	You can set a time interval for the fax to wait until it automatically enters the document receive mode when the fax is set for manual receiving. (→16-12)
Telephone line	TEL LINE TYPE	Your fax is set to operate on a rotary pulse telephone line. (→3-10, 16-6)

<b>Feature</b>	<b>Menu Item</b>	<b>Description of default</b>
Transmission error: document in memory	ERASE FAILED TX	If a transmission error occurs, the document remains in the memory. You can set the fax to erase the document from the memory if an error occurs during transmission. (→16-10)
Unit Name, Unit Telephone Number	DATE & TIME UNIT TELEPHONE # UNIT NAME	Your registered identification and fax number are printed at the top and outside of the image border of every document you send. Your number is prefixed with the word "FAX". (→3-11, 16-4)





# Chapter 13

## Restricting Use of the Fax

---

In this chapter we will show you how to protect the fax from unauthorized access.

Some of these features also allow you to keep track of fax transactions based on division numbers or user access codes that you can assign to individuals or sections inside your company.

Setting and Using the System Settings Password .....	13-2
Setting the System Settings Password .....	13-2
Changing or Cancelling the System Settings Password .....	13-3
Restricting Fax Operation .....	13-5
Setting Operation Restrictions .....	13-5
Operating the Fax with Restrictions ON .....	13-9
Turning Restrictions OFF and ON .....	13-12
Receiving Documents from Registered Senders Only .....	13-14
Using Memory Lock .....	13-15
Setting a Time and Password for Memory Lock .....	13-15
Turning Memory Lock ON .....	13-18
Turning Memory Lock OFF and Printing Documents .....	13-18

# Setting and Using the System Settings Password

The system settings password protects all the settings in the System Settings menu.



---

If you fail to create and safeguard a system password, then anyone can open the System Settings menu and change or disable the settings.

---

## Setting the System Settings Password

Follow this procedure to set the system settings password.

1. Open the SYSTEM SETTINGS menu.

Open both One-touch Speed Dialling panels. Then press DATA REGISTRATION.



DATA REGISTRATION



SET



REGISTRATION  
1.DATA REGISTRATION

Press SET.

DATA REGISTRATION  
1.USER SETTINGS

Press the search buttons until you see the display below.



DATA REGISTRATION  
7.SYSTEM SETTINGS

Press SET.

SYSTEM SETTINGS  
1.PASSWORD

2. Set the system password.

Press SET.

SET



PASSWORD  
\_



Use the buttons on the numeric keypad to enter a four-digit password between 0000 and 9999.

PASSWORD 3377

- Record the password number and store it in a safe location.



You must enter this system password every time you open the System Settings menu.



Press SET.

SYSTEM SETTINGS  
2.RESTRICTIVE CODES



- Press STOP to return to standby.

## Changing or Cancelling the System Settings Password

Follow this procedure to cancel or change the System Settings password.

- Open the SYSTEM SETTINGS with your password.

Open both One-touch Speed Dialling panels. Then press DATA REGISTRATION.



DATA REGISTRATION



REGISTRATION  
1.DATA REGISTRATION



Press SET.

DATA REGISTRATION  
1.USER SETTINGS



Press the search buttons until you see the display below.

DATA REGISTRATION  
7.SYSTEM SETTINGS



Press SET.

SYSTEM SETTINGS  
PASSWORD \_

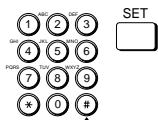

Enter the current four-digit system settings password. Then press SET.

SYSTEM SETTINGS  
1. PASSWORD



2. Press SET.

PASSWORD \_

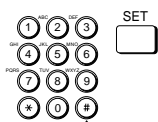

3. Use the buttons on the numeric keypad to enter the current password. Then press SET. The current password is not displayed as it is entered.

PASSWORD \_

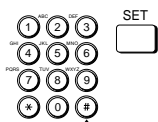

4. Enter the new password and press SET. The new password is displayed as it is entered.

-or-

To cancel the password setting, press CLEAR then SET.

SYSTEM SETTINGS  
2. RESTRICTIVE CODES

5. Press STOP to return to standby.



# Restricting Fax Operation

This section describes how to set up restrictions on operation of the fax. We will first show you how to set up restrictions on sending documents, printing fax reports and copying, and using the telephone. Then we will show you how to use the fax with these restrictions on. Finally, we will show you how to turn these restrictions off temporarily or make changes in the settings.

The table below is a brief summary of how restrictive codes and passwords are used.

SENDING RESTRICTION	Dept. access code (DAC) ON	Dept. access code	With a password	Every time you send a document, you must enter a department code and password.
			Without a password	Every time you send a document, you only have to enter a department code.
	Dept. access code (DAC) OFF	With user access code		Every time you send a document, you only have to enter a user access code.
		No user access code		You can not send a document unless you turn sending restriction OFF.
PRINTING RESTRICTION	With user access code			Every time you make a copy or print a report, you must enter a user access code.
	Without user access code			You can not print unless you turn printing restriction OFF.
TELEPHONE RESTRICTION	ON			You can not dial unless you turn telephone restriction OFF.

## Setting Operation Restrictions

You can create up to 99 department access codes (DACs) and passwords to restrict sending operations on the fax. Follow this procedure to restrict access to all of these features:

- Sending documents
  - Copying documents and printing fax reports
  - Using the telephone for voice communication
1. Open the SYSTEM SETTINGS menu with your system settings password. (→13-3)

SYSTEM SETTINGS 1. PASSWORD
--------------------------------



2. Press the search buttons until you see the display below.

SYSTEM SETTINGS  
2.RESTRICTIVE CODES

3. Turn on the transmission restriction feature.

Press SET.



RESTRICTIVE CODES  
1.TX SETTINGS

Press SET.



TX SETTINGS OFF

Press the search buttons until you see the display below.



TX SETTINGS ON

Press SET.



DAC SETUP OFF

4. Enter the department access codes.

Press the search buttons to display ON then press SET.

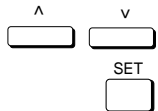

DAC SETUP ON

ENTER DAC  
01:

-or-

If the first number is already in use, press the search buttons until you see an empty line.

-or-

If you do not want to set a department access code (DAC) and want to use only the user access code for transactions, use the search keys to display OFF, then press SET and go on to step 6 to set the user access code. If you set only the user access code, you have to enter only the user access code when you send a document.



Press SET.

5. Enter the department access code (DAC). Example 01.

Use the buttons on the numeric keypad to enter a four-digit code for the department access code.



Press SET.

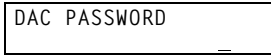

6. Enter the department access code password or the user access code.

Use the buttons on the numeric keypad to enter a four-digit code for the department access code password or the user access code.

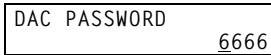

or

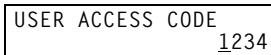

Press SET.

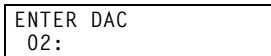

-or-

If you do not want to enter a password and you want to use only the department access code for transactions, just press SET and go on to the next step. If you set only the department access code, you have to enter only the department access code when you send a document.

You can now repeat steps 4 and 5 to enter other department access codes and passwords.

ENTER DAC  
10:

DATA REGISTRATION

[ ]

7. When you are finished, press DATA REGISTRATION to return to the previous level of the menu.

RESTRICTIVE CODES  
2.PRINTER SETTINGS

8. Turn on the restrictions for printing.

Press SET.

SET  
[ ]

PRINTER SETTINGS  
OFF

Press the search buttons to display ON.

^ [ ] v  
[ ] [ ]

PRINTER SETTINGS  
ON

Press SET.

SET  
[ ]

USER ACCESS CODE  
\_

9. Enter a user access code to protect the copying and printing features.

Use the buttons on the numeric keypad to enter a four-digit user access code.

This user access code is used only to restrict access to copying and printing.



USER ACCESS CODE  
2894





Press SET.

RESTRICTIVE CODES  
3.TEL SETTING

10. Turn off access to the telephone.



Press SET.

TEL SETTING                      OFF



Press the search buttons to display ON.

TEL SETTING                      ON



Press SET. This disables the telephone handset and the HOOK button on the operation panel.

This concludes the restrictive settings for sending, printing, and using the telephone.



11. Press STOP to return to standby.

## ***Operating the Fax with Restrictions ON***

This section describes how to operate the fax with the operation restriction features set up and turned on.

### ***Sending a Document with Restrictions ON***

Follow this procedure to send a document after department access codes (DAC) and passwords have been set up.



1. Set the document on the fax. (→6-3)

Set the document resolution, contrast, and document type. (→6-4)

You can also select a sender's name with the TTI SELECTOR. (→6-6)

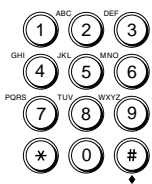

2. Dial the other party's fax number.

Use regular dialling to dial a number. (→6-7)

-or-

Press a One-touch Speed Dialling button to dial the number. (→4-26)

-or-

Press CODED DIAL and a three-digit code to dial the number. (→4-28)

-or-

Dial the number with directory dialling. (→4-31)

3. Press START/SCAN.

If you see this message, you have to enter the department access code. Go on to step 4.

ENTER DAC

-or-

If you see this message, you have to enter the user access code. Go on to step 5.

USER ACCESS CODE

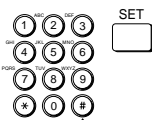
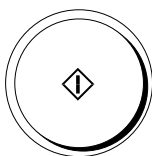

4. Enter the DAC (department access code).

Use the buttons on the numeric keypad to enter the four-digit DAC (department access code) then press SET.

DAC PASSWORD

If you enter the wrong department access code, the fax beeps and waits for you to enter the correct code.

5. Enter the DAC password or user access code.

Use the buttons on the numeric keypad to enter the four-digit DAC password or user access code then press SET.

If you enter the wrong password, the fax beeps and waits for you to enter the correct password.

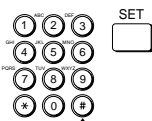

After you enter the department access code and password correctly or user access code, the fax sends the document.

## **Making a Copy with Restrictions ON**

Follow this procedure to make a copy with the printing restriction set up and turned on.

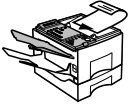

1. Set the document on the fax.

DOCUMENT READY



2. Press COPY.

USER ACCESS CODE

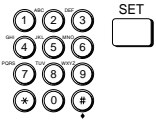

3. Use the buttons on the numeric keypad to enter the four-digit user access code that you set previously to restrict access to copying. Then press SET.

COPY 01  
FRONT UPPER CAS. A4

4. Follow the normal procedure to complete copying the document. (→5-5)

## **Printing a Report with Restrictions ON**

Follow this procedure to print a report about information stored in the fax with the printing restriction set up and turned on.



REPORT



1. Open both One-touch Speed Dialling panels. Then press REPORT.

REPORT  
1.ACTIVITY REPORT



2. Press the search buttons to select the type of report you want to print then press SET.



USER ACCESS CODE

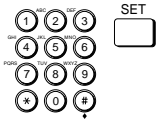

- Use the buttons on the numeric keypad to enter the four-digit user access code you set to protect printing reports. Then press SET.

The fax starts printing the report.

PRINTING REPORT

## Using the Telephone with Restrictions ON

When the telephone restriction feature is turned on, the handset and HOOK button are disabled. If you pick up the handset or press the HOOK button, you will not hear a dial tone.

## Turning Restrictions OFF and ON

Follow this procedure to turn off the following features temporarily without changing the settings.

- Open the SYSTEM SETTINGS menu with your system settings password. (→13-3)

SYSTEM SETTINGS  
1.PASSWORD



- Press the search buttons until you see the display below.

SYSTEM SETTINGS  
2.RESTRICTIVE CODES



- Press SET.

RESTRICTIVE CODES  
1.TX SETTINGS



- Press the search buttons to display the feature you want to turn off.

RESTRICTIVE CODES  
1.TX SETTINGS

RESTRICTIVE CODES  
3.TELEPHONE SETTINGS



### To Turn Off Restricted Sending

Press the search buttons until you see the display below.

RESTRICTIVE CODES  
1.TX SETTINGS



Press SET.

TX SETTINGS ON



Press a search button to display OFF, then press SET.



### To Turn Off Restricted Printing

Press the search buttons until you see the display below.



RESTRICTIVE CODES  
2.PRINTER SETTINGS



Press SET.

PRINTER SETTINGS ON



Press a search button to display OFF, then press SET.



### To turn off restricted use of the telephone

Press the search buttons until you see the display below.



RESTRICTIVE CODES  
3.TEL SETTING



Press SET.

TEL SETTING ON



Press a search button to display OFF, then press SET.





5. Press STOP to return to standby.



---

To turn the settings on again, just repeat this procedure from step 1 and select ON.

---

## Receiving Documents from Registered Senders Only

Follow this procedure to turn restricted receiving on and off. Restricted receiving limits document reception to fax units whose telephone numbers are registered on your fax for One-touch or Coded Speed Dialling buttons. You can not receive a document from another fax unless it is registered on your fax for a speed dialling button, so the fax will not receive unsolicited direct mail.

1. Open the SYSTEM SETTINGS menu with your system settings password. (→13-3)
2. Press the search buttons until you see the display below.



SYSTEM SETTINGS  
4.RX RESTRICTION

3. Press SET.



4. Press the search buttons to display the setting you want, then press SET.

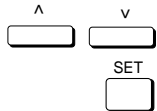

RX RESTRICTION      OFF

RX RESTRICTION      ON

- OFF      Your fax will receive a document even if the fax telephone number of the originator is not registered on your fax for a One-touch Speed Dialling button or a Coded Speed Dialling code. However, other restrictions like passwords, subaddresses, and so on, still apply.
- ON      Your fax will receive a document only if the fax telephone number of the originator is registered on your fax for a One-touch Speed Dialling button or a Coded Speed Dialling code.



5. Press STOP to return to standby.

# Using Memory Lock

Normally a document prints as soon as you receive it. However, there may be occasions when you want the fax to store all documents in the memory until you are ready to print them. Locking the fax to receive and store all documents in the memory is called *memory lock*.

You may want to turn memory lock on when the fax is left unattended at night or over long holidays to prevent a large volume of printed documents from collecting on the paper output tray. After you return to the office, you can review the contents of the memory and then enter the memory lock password to print all the documents stored in the memory.

## Setting a Time and Password for Memory Lock

After memory lock is turned on, the fax will automatically enter and leave the memory lock mode at times you specify. The documents received when the fax is in the memory lock mode are stored in the memory until you unlock the memory with a password and print them.

Follow the procedure below to define a memory lock password and set the times for the fax to enter and leave the memory lock mode.

1. Open the MEMORY LOCK menu.

Open both One-touch Speed Dialling panels. Then press DATA REGISTRATION.



DATA REGISTRATION



REGISTRATION  
1.DATA REGISTRATION

SET



Press SET.

DATA REGISTRATION  
1.USER SETTINGS

^



v



Press the search buttons until you see the display below.

DATA REGISTRATION  
7.SYSTEM SETTINGS

SET

Press SET. Be sure to enter your system settings password if you have one.

SYSTEM SETTINGS  
1.PASSWORD

^ v

Press the search buttons until you see the display below.

SYSTEM SETTINGS  
3.MEMORY LOCK RX

SET

Press SET.

MEMORY LOCK RX OFF

2. Turn on the memory lock feature.

^ v

Press the search buttons until you see the display below.

MEMORY LOCK RX ON

SET

Press SET.

^ v  
   
SET

3. Press the search buttons to display the setting you want and press SET.

MEMORY LOCK RX  
1.MEM LOCK PASSWORD

MEMORY LOCK RX  
3.TIME SETUP

4. For details about setting up the memory lock feature, refer to the summary below.



## Memory Lock Setup Summary

The default settings, shown in bold, remain in effect unless you change them.

---

1.MEM LOCK PASSWORD	0000 to 9999
	This password protects the memory lock settings. You must also use this password to unlock the memory so you can print documents stored in the memory. Use the buttons on the numeric keypad to enter a four-digit password and press SET.
2.REPORT	Set the fax to print reports or not. This setting affects only reports that print automatically, such as Activity Reports for sending and receiving, and Activity Management Reports.
	<b>OUTPUT NO</b> A report is not printed while in the memory lock mode.
	<b>OUTPUT YES</b> A report is printed while the fax is in the memory lock mode.
3.TIME SETUP	Set the times for the fax to enter and leave the memory lock mode. The time settings are optional. If you do not set the times, you can use the MEMORY RECEPTION button to turn the memory lock feature on and off.
	<b>OFF</b> Turns off the timer setup. You can turn the memory lock mode on and off with the MEMORY RECEPTION button.
	<b>ON</b> Turns on the timer setup. You can still use the MEMORY RECEPTION button to turn the memory lock mode on and off.
	<b>START TIME</b> Sets the time for the fax to enter the memory lock mode.
	<b>EVERYDAY SELECT DAYS</b> Set the time in 24-hour format. Up to 5 starting times can be specified for every day or each selected day.
	<b>END TIME</b> Sets the time for the fax to leave the memory lock mode.
	<b>EVERYDAY SELECT DAYS</b> Set the time in 24-hour format. Up to 5 starting times can be specified for every day or each selected day.

---

## Turning Memory Lock ON

Follow this procedure to put the fax in the memory lock mode if the memory lock mode timer has not been set or if you want to put the fax in the memory lock mode before the timer turns memory lock on.



---

If the timer is set for the memory lock feature, the fax will enter and leave the memory lock mode automatically.

---



MEMORY RECEPTION



1. Open both One-touch Speed Dialling panels. Then press MEMORY RECEPTION.

MEM LOCK PASSWORD

—

Enter the memory lock password then press SET.

MEMORY LOCK RX

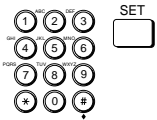

The fax is now in the memory lock receive mode. All documents will be received in the memory until you unlock memory receiving and print them.

## Turning Memory Lock OFF and Printing Documents

Follow this procedure to turn memory lock off and print the documents received in the memory.



---

If the timer is set for the memory lock feature, the fax will enter and leave the memory lock mode automatically. (→13-15)

---

1. When memory lock is on, a message is displayed.

MEMORY LOCK RX

2. Open both One-touch Speed Dialling panels. Then press MEMORY RECEPTION.

MEM LOCK PASSWORD

—



MEMORY RECEPTION



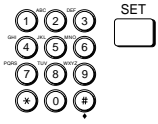

3. Use the buttons on the numeric keypad to enter the four-digit memory lock password and press SET.

All the documents received in the memory while the fax was in the memory lock mode are printed.



# Chapter 14

## Printing Reports and Lists

---

This chapter shows you how to print lists and reports.

You can print lists of telephone numbers and transmissions settings registered in the fax, as well as print reports about document transactions.

Printing the Speed Dialling Lists .....	14-2
Printing the User Data List .....	14-5
Printing the List of Sender Names .....	14-6
Activity Reports .....	14-7
Printing the Activity Management Report .....	14-7
Setting and Using Activity Reports .....	14-9
Memory Lists .....	14-15

# Printing the Speed Dialling Lists

Follow this procedure to print the speed dialling lists. You can print two types of One-touch or Coded Speed Dialling list: a standard list (List 1) or a detailed list (List 2).



REPORT



1. Open the SPEED DIAL LIST menu.

Open both One-touch Speed Dialling panels. Then press REPORT.

```
REPORT
1.ACTIVITY REPORT
```

Press the search buttons until you see the display below.

```
REPORT
2.SPEED DIAL LIST
```

Press SET.

```
SPEED DIAL LIST
1.1-TOUCH LIST
```

2. Press the search buttons to display the name of the list you want to print.

- |                    |  |
|--------------------|--|
| 1.1-TOUCH LIST     | Prints the standard list (List 1) of all One-touch Speed Dialling buttons and numbers registered in the fax.                     |
| 2.CODED DIAL LIST  | Prints the standard list (List 1) of all Coded Speed Dialling buttons and numbers registered in the fax.                         |
| 3.1-TOUCH (DETAIL) | Prints the detailed list (List 2) of all One-touch Speed Dialling buttons and numbers registered in the fax in a stacked format. |
| 4.CODED (DETAIL)   | Prints the detailed list (List 2) of all Coded Speed Dialling buttons and numbers registered in the fax in a stacked format.     |
| 5.GROUP DIAL LIST  | Prints the list of buttons and numbers registered for Group Dialling.  |



3. Press SET.

The Group Dial list starts printing.

SORTED OUTPUT  
1.NO

1.NO The One-touch or Coded Speed Dial list is printed in order of the Speed Dial numeric list, from the lowest number to the highest number.

2.YES The Connection ID (name) column is sorted and the One-touch or Coded Speed Dial list is printed in alphabetical order.

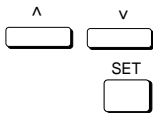

4. Press the search buttons to display YES or NO. Press SET.

After you press SET, the report starts printing.

PRINTING REPORT

Samples of each type of list are shown below.

### One-Touch Speed Dial List 1

26/12 '97 14:22 FAX 833 4423 WORLD ESTATE, INC. <span style="float:right">☑001</span>				
* * * * *				
* 1-TOUCH SPD DIAL LIST 1 *				
* * * * *				
NO.	CONNECTION TEL	CONNECTION ID	TX TYPE	⌚
[ 01]	732 2233	ADAM BOOKS, CPA	MEMORY TX	
[ 02]	761 1298	JOHN BARRISTER, ESQ.	MEMORY TX	23:30
[ 03]	1 914 438 3619	SEYMOUR GREEN, INC.	MEMORY TX	23:30
[ 04]	1 516 911 4411	NATALIE SMITH, CPM	MEMORY TX	

### Coded Speed Dial List 1

26/12 '97 15:42 FAX 833 4423 WORLD ESTATE, INC. <span style="float:right">☑001</span>				
* * * * *				
* CODED SPEED DIAL LIST 1 *				
* * * * *				
NO.	CONNECTION TEL	CONNECTION ID	TX TYPE	⌚
[#000]	555 1234	BILL	MEMORY TX	
[#001]	14043333499	PEACHTREE, INC.	MEMORY TX	23:30
[#002]	16172223322	HUNT INVESTMENTS	MEMORY TX	23:30
[#003]	1 312 538 4005	LAKESIDE INC.	MEMORY TX	

### One-Touch Speed Dialling List 2

26/12 '97 16:00 FAX 833 4423	WORLD ESTATE, INC.	☑001
* * * * * * 1-TOUCH SPD DIAL LIST 2 * * * * * *		
[ 01]	CONNECTION TEL	889 344 222
	CONNECTION ID	AK ENTERPRISES
	TX START TIME	(1) 10:00 (2) 12:00 (3) 14:00 (4) 16:00 (5) 18:00
	TX SPEED	14400bps(1)
	TX TYPE	REGULAR TX
	ECM	ON
[ 02]	CONNECTION TEL	513 931 7660
	CONNECTION ID	ENVIRONS CORP.
	TX START TIME	(1) 23:30 (2) 08:00 (3) (4) (5)
	TX SPEED	14400bps(1)
	TX TYPE	REGULAR TX
	ECM	ON

### Coded Speed Dial List 2

26/12 '97 16:00 FAX 833 4423	WORLD ESTATE, INC.	☑001
* * * * * * CODED SPEED DIAL LIST 2 * * * * * *		
[*024]	CONNECTION TEL	982 8877
	CONNECTION ID	AK ASSOCIATES
	TX START TIME	(1) 10:00 (2) 12:00 (3) 14:00 (4) 16:00 (5) 18:00
	TX SPEED	14400bps(1)
	TX TYPE	REGULAR TX
	BCM	ON
[*075]	CONNECTION TEL	712 0965
	CONNECTION ID	T&S DESIGNS
	TX START TIME	(1) 23:30 (2) 08:00 (3) (4) (5)
	TX SPEED	14400bps(1)
	TX TYPE	REGULAR TX
	BCM	ON

### Group Dial List

26/12 '97 16:00 FAX 833 4423	WORLD ESTATE, INC.	☑001
* * * * * * GROUP DIAL LIST * * * * * *		
[ 05] CANON GROUP	[*001] 225 7823	CANON NY
	[*010] 233 7766	CANON CA
	[ 01] 876 2398	CANON TX
	[ 02] 613 9076	CANON OH



# Printing the User Data List

Follow this procedure to print a comprehensive list of the current user data and other settings.



REPORT

^      v  
  

1. Open both One-touch Speed Dialling panels. Then press REPORT.

REPORT  
 1.ACTIVITY REPORT

2. Press the search buttons until you see the display below.

REPORT  
 3.USER DATA LIST

SET

3. Press SET.

USER DATA LIST  
 1.USER DATA

SET

4. Press SET to start printing.

After you press SET, the report starts printing.

PRINTING REPORT

## User's Data List

26/12 '97 17:00 FAX 833 4423	WORLD ESTATE, INC.	☑001
* * * * * *    USER'S DATA LIST    * * * * * *		
1.USER SETTINGS		
UNIT TELEPHONE #		
UNIT NAME		
TX TERMINAL ID	ON	
TTI POSITION		OUTSIDE IMAGE
TELEPHONE # MARK		FAX
-----		
MULTIPLE PG BATCH TX		
4.RX SETTINGS		
ECM RX	ON	
MAN/AUTO SWITCH	OFF	
REMOTE RX		ID CALL#
REMOTE RX ID		25
MEMORY RX	ON	
MEMORY RX ALARM		OFF
RX PAGE FOOTER	OFF	

# Printing the List of Sender Names

Follow this procedure to print a list of sender names registered in the fax.

- The sender names are names registered to print at the top of documents you send in place of the unit name. (→3-12)
- Sender names are selected by pressing TTI SELECTOR just before you send a document. (→6-6)



REPORT

^      v  
  

1. Open both One-touch Speed Dialling panels. Then press REPORT.

REPORT  
 1.ACTIVITY REPORT

2. Press the search buttons until you see the display below.

REPORT  
 3.USER DATA LIST

SET

3. Press SET.

USER DATA LIST  
 1.USER DATA

^      v  
  

4. Press the search buttons until you see the display below.

USER DATA LIST  
 2.SENDER'S NAME

SET

5. Press SET.

After you press SET, the report starts printing.

PRINTING REPORT

## Sender Name List

26/12 '97 15:02 FAX 833 4423	WORLD ESTATE, INC.	☑001
* * * * *		
*            SENDER NAME LIST            *		
* * * * *		
01:R. LOUIS 04:B. THOMAS	02:S. ROBERTS 05:F. DILLON	03:R. SEAL 06:B. DWYER

# Activity Reports

Activity reports contain information about past fax transactions. The Activity Management Report prints a list of the past 40 transactions, and other activity reports report information about transactions as they occur.

Here is a summary of some of the abbreviations used in activity reports.

- ST. TIME** Represents the time the last attempt was made to transmit a document.
- USAGE T** Represents the amount of time it took during the last attempt to transmit. Note that the usage time does not reflect the total usage time used to transmit all pages of the document when a retry occurs. By printing an **ACTIVITY MANAGEMENT REPORT** and matching the transaction number of the **TX REPORT** with a transaction number of in the **ACTIVITY MANAGEMENT REPORT** you can know exactly how many attempts were made to send the document, how many pages were sent in each attempt as well as the usage time for each attempt.
- PGS. SENT** Represents the total number of pages that were successfully transmitted.
- RESULT** OK means all pages were transmitted either during the first attempt or after the first or second retry.  
The default, which is two retries, can be changed. (→6-16, 16-10)  
NG means that either some or no pages were transmitted after two retries. The default, which is two retries, can be changed. (→6-16, 16-10)

## Printing the Activity Management Report

Follow this procedure to print a list of the previous 40 transactions on your fax.



REPORT



SET



1. Open both One-touch Speed Dialling panels. Then press REPORT.

REPORT  
1.ACTIVITY REPORT

2. Press SET.

After you press SET, the fax prints an Activity Management Report in the standard format with all transactions listed chronologically.

**Activity Management Report**

26/12 '97 13:14 FAX 833 4423 WORLD ESTATE, INC. <span style="float:right">☑001</span>						
***** *       ACTIVITY REPORT       * *****						
ST. TIME	CONNECTION TEL/ID	SENDER NAME	NO.	MODE	PGS.	RESULT
26/12 09:49	761 1298	JOHN BARRISTER, ESQ.	0085	TRANSMIT TX	1	OK 00'17
26/12 10:45	1 81 3 758 2111	CANON INC.	0086	TRANSMIT TX	2	OK 00'58
26/12 15:38	R.LOUIS 1 213 554 3377	CALIFORNIA CENTER	0087	TRANSMIT TX	0	NG 00'29 0 #224
26/12 16:32	R.LOUIS 1 213 554 3377	CALIFORNIA CENTER	0088	RECEIVE RX	2	OK 00'32

You can set the fax to print sending and receiving transactions separately by setting the **ACTIVITY REPORT** item in the Report Settings menu. (→16-8)

Samples are shown below.

**Activity Management Report (TX/RX separate)**

26/12 '97 13:14 FAX 833 4423 WORLD ESTATE, INC. <span style="float:right">☑001</span>						
***** *       ACTIVITY MANAGEMENT REPORT TX       * *****						
ST. TIME	CONNECTION TEL/ID	SENDER NAME	NO.	MODE	PGS.	RESULT
26/12 09:49	761 1298	JOHN BARRISTER, ESQ.	0085	TRANSMIT ECM	1	OK 00'17
26/12 10:45	1 81 3 758 2111	CANON INC.	0086	TRANSMIT ECM	2	OK 00'58
26/12 15:38	R.LOUIS 1 213 554 3377	CALIFORNIA CENTER	0087	TRANSMIT ECM	0	NG 00'29 0 #224

***** *       ACTIVITY MANAGEMENT REPORT RX       * *****						
ST. TIME	CONNECTION TEL/ID	RX NAME	NO.	MODE	PGS.	RESULT
*26/12 12:45	JOHN BARRISTER 444 5380		5022	AUTO RX ECM	12	NG 04'16 4 STOP
*26/12 12:50	COURTHOUSE 222 1111		0074 *5023	POLLING RX ECM	3	NG 01'16 0 #018

If marked with an asterisk, the document has already been printed out.

- Transaction number
- Sending mode
- Transaction via Error Correction Mode (ECM)
- Number of pages with an error
- Error codes (see table in Chapter 15)
- STOP was pressed during transaction

Note the following additional features you can set up with the ACTIVITY REPORT item in the Report Settings menu.

- The fax is set to print an Activity Management Report automatically after 40 transactions. You can turn this feature off. (→16-8)
- You can set the fax to print an Activity Management Report at the same time every day. (→16-8)
- If you set up department access codes, when this feature is turned on transactions are listed by department in the Department Access Code Report shown below.

**Department Access Code Report**

26/12 '97 16:43 FAX 833 4423 WORLD ESTATE, INC. <span style="float:right">001</span>						
* * * * * * ACTIVITY REPORT * * * * * *						
DEPT. ACCESS CODE: 1222						
ST. TIME	CONNECTION TEL/ID	SENDER NAME	NO.	MODE	PGS.	RESULT
26/12 15:18	ADAM BOOKS, CPA 732 2233	03:S.ROBERTS	0080	TRANSMIT ECM	1	OK 00'31
DEPT. ACCESS CODE: 3111						
ST. TIME	CONNECTION TEL/ID	SENDER NAME	NO.	MODE	PGS.	RESULT
26/12 15:30	COURTHOUSE 788 1265	01:R.LOUIS	0081	TRANSMIT ECM	2	OK 00'58

**Setting and Using Activity Reports**

For details about setting up these activity reports to print (or turning them off) refer to the Report Settings summary at the end of this User's Guide. (→16-7)

**Error Report (TX)**

The fax is set to print a report if an error occurs during sending. This is the default setting for the Report Settings. (→16-7)

26/12 '97 13:23 FAX 833 4423		WORLD ESTATE, INC.	
* * * * * * ERROR TX REPORT * * * * * *			
TX FUNCTION WAS NOT COMPLETED			
TX/RX NO	0017		
CONNECTION TEL	1 213 978 3314		
SUBADDRESS	#006		
CONNECTION ID	BELZER, INC.		
ST. TIME	26/12 13:35		
USAGE T	00'00"		
PGS. SENT	0		
RESULT	NG	STOP	

### Transmission (TX) Report

You can change the Report Settings to print a transmission report for every document you send. (→16-7)

26/12 '97 14:26 FAX 833 4423	WORLD ESTATE, INC.	001
*****		
* TX REPORT *		
*****		
TRANSMISSION OK		
TX/RX NO	0015	
DEPT. ACCESS CODE	1322	
CONNECTION TEL	1 213 978 3314	
SUBADDRESS	#4622	
CONNECTION ID	BELZER, INC.	
ST. TIME	26/12 13:23	
USAGE T	00'17	
PGS. SENT	1	
RESULT	OK	

### Transmission (TX) Report with first page

You can adjust the transmission report setting to print the first part of the document as part of the report to remind you of the content of the document. (→16-7) This is only effective when you send documents by Memory Sending.

26/12 '97 14:26 FAX 833 4423 WORLD ESTATE, INC. 001

\* \* \* \* \*  
\* TX REPORT \*  
\* \* \* \* \*

TRANSMISSION OK

TX/RX NO	0015
DEPT. ACCESS CODE	2222
CONNECTION TEL	1 213 978 3314
SUBADDRESS	#2399
CONNECTION ID	BELZER, INC.
ST. TIME	26/12 13:23
USAGE T	00'17
PGS. SENT	1
RESULT	OK



### WORLD ESTATE, INC.

West 44th Street  
New York, NY  
U.S.A.

*Global Real Estate Consultants in the Heart of New York*

December 28, 1995

Dear Member,

By now you have all had a chance to become familiar with your new Canon fax units and are ready to set up a reliable, economical communications network that offers many exciting features.

We can save money by scanning documents in the memory and then setting the delayed timer to send all the documents at the same time later at night to take advantage of late night rates.

Many of us are separated by long distances and reside in different time zones. We can set up the polling feature to poll and receive documents from each other when we are not in the office. For sensitive material about clients and confidential bids, we can set up and use the confidential mailbox features. We will also be able to keep down costs by limiting use of the fax to operators who know the correct department codes and passwords.

Relay sending is another money saver. We can designate one relay fax in your area, send one transmission from the home office on the East coast and then have the document relayed to you locally

We hope you will have these features set up in the very near future so we can enjoy more efficient, secure, and economical facsimile communications.

This item appears only if the DAC (Department Access Code) has been set.

### Multi-transaction Report

If the transmission was a sequential broadcast, then a Multi-transaction Report is printed.

```
26/12 '97 16:00 FAX 833 4423 WORLD ESTATE, INC. 001
* * * * *
* MULTI TX/RX REPORT *
* * * * *

TX/RX NO 0094
PGS. 1
TX/RX INCOMPLETE -----
TRANSACTION OK [ 01] 732 2233 ADAM BOOKS, CPA
[ 02] 444 5380 JOHN BARRISTER, ESQ
[ 03] 477 3299 SEYMOUR GREEN
ERROR INFORMATION -----
```

### Error Report (RX)

You can set the fax to print a report every time an error occurs during document receiving. Otherwise, only an error message is displayed. (→16-7)

```
26/12 '97 13:23 FAX 833 4423 WORLD ESTATE, INC.
* * * * *
* RX REPORT *
* * * * *

INCOMPLETE RECEPTION

TX/RX NO 5025
CONNECTION TEL 1 213 978 3314
SUBADDRESS #005
CONNECTION ID BELZER, INC.
ST. TIME 26/12 13:35
USAGE T 00'00"
PGS. 0
RESULT NG #037
```



### Reception (RX) Report

You can set the fax to print an activity report every time you receive a document.  
(→16-8)

26/12 '97 14:26 FAX 833 4423	WORLD ESTATE, INC.	☑001
*****		
* RX REPORT *		
*****		
RECEPTION OK		
TX/RX NO	5015	
CONNECTION TEL	444 5380	
SUBADDRESS	#2641	
CONNECTION ID	SEYMOUR GREEN, INC.	
ST. TIME	26/12 13:23	
USAGE T	00'17	
PGS.	1	
RESULT	OK	

### Confidential Receive Report

When the fax receives a confidential document, it displays a message and prints a report.

RECEIVED IN MAILBOX

26/12 '97 14:26 FAX 833 4423	WORLD ESTATE, INC.	☑001
*****		
* CONFID. RX REPORT *		
*****		
CONFID. MBOX#	#01	
CONFID. MBOX NAME	LOUIS	
TX/RX NO	5028	
CONNECTION TEL	444 5380	
SUBADDRESS	1234	
CONNECTION ID	JOHN BARRISTER	
ST. TIME	26/12 13:13	
USAGE T	00'56	
PGS.	1	
RESULT	OK	

Printing this report can be turned off with the User Data Settings. (→16-8)

### Memory Box Report

The fax prints a Memory Box Report as soon as a document is received in a memory box.

```
26/12 '97 16:00 FAX 833 4423 WORLD ESTATE, INC. 001
* * * * *
* MEMORY BOX REPORT *
* * * * *

BOX# #66
FILE NAME R.LOUIS
TX/RX NO 5028
CONNECTION TEL 444 538
SUBADDRESS #061348
CONNECTION ID CANON INC.
ST. TIME 26/12 11:00
USAGE T 00'55
PGS. 1
RESULT OK
```

This feature can be turned off with the User Data Settings. (→16-8)

### Relay Broadcast Report

The Relay Broadcast Report is sent from a relay unit to the originator after the documents from the originator have been relayed by the relay unit. This feature is set with the TX REPORT item in the RELAY TX GROUP menu. (→9-8, 16-18)

```
26/12 '97 16:00 FAX 833 4423 WORLD ESTATE, INC. 001
* * * * *
* RELAY BROADCAST REPORT *
* * * * *

TX/RX NO 5033
PGS. 2
TX/RX INCOMPLETE -----
TRANSACTION OK [ 01] 821 7434 ADAM BOOKS, CPA
[ 02] 931 7660 JOHN BARRISTER, ESQ
[ 03] 291 4564 SEYMOUR GREEN
ERROR INFORMATION -----
```

# Memory Lists

These reports list information about what is contained in the memory at the current time.

## Confidential Mailbox List

Follow this procedure to print a list of all confidential mailboxes registered in the fax. This list also shows you which confidential mailboxes are currently holding documents.



---

This list does not list the passwords for the confidential mailboxes.

---



1. Open both One-touch Speed Dialling panels. Then press REPORT.

REPORT  
1.ACTIVITY REPORT

2. Press the search buttons until you see the display below.

REPORT  
5.CONF MAILBX LIST



3. Press SET to start printing the report.

PRINTING REPORT

26/12 '97 16:00 FAX 833 4423	WORLD ESTATE, INC.	001
* * * * *		
* CONFID. MAIL BOX REPORT *		
* * * * *		
CONFID. MBOX#	CONFID. MBOX NAME	PGS.
01	LOUIS	1
02	ROBERTS	3
03	THOMAS	4
04	DILLON	2

### Document Memory List

Follow this procedure to print a Document Memory List for all documents currently stored in the memory.



REPORT



1. Open both One-touch Speed Dialling panels. Then press REPORT.

REPORT  
1.ACTIVITY REPORT

2. Press the search buttons until you see the display below.

REPORT  
4.DOC. MEMORY LIST

SET



3. Press SET.

PRINTING REPORT

26/12 '97 15:03 FAX 833 4423				WORLD ESTATE, INC.		001
* * * * *						
* DOC. MEMORY LIST *						
* * * * *						
TX/RX NO	MODE	CONNECTION TEL/ID	PGS.	SET TIME	ST. TIME	SENDER NAME
5443	DELAYED TX	[#10] J.SMITH	5	26/12 17:40	00:33	R.LOUIS

### Received memory box list

Follow this procedure to list all documents currently received and held in memory boxes.



REPORT



1. Open both One-touch Speed Dialling panels. Then press REPORT.

REPORT  
1.ACTIVITY REPORT

2. Press the search buttons until you see the display below.

REPORT  
6.RX MEM. BOX LIST



3. Press SET.

PRINTING REPORT

26/12 '97 15:03 FAX 833 4423		WORLD ESTATE, INC.	
* * * * *			
* RECEIVED MEMORY BOX LIST *			
* * * * *			
BOX#	FILE NAME	PGS.	
66	R.LOUIS	1	

**Memory Clear Report**

If a power failure occurs, the documents currently in the memory can be saved for up to approximately 12 hours. If power is not restored to the fax within 12 hours, the documents in the fax memory will be lost. If this time limit has elapsed by the time power is restored to the fax unit, as soon as power is restored a list of documents deleted from the memory as a result of the power failure is printed automatically.

26/12 '97 14:22 FAX 833 4423		WORLD ESTATE, INC.		001
* * * * *				
* MEMORY CLEAR REPORT *				
* * * * *				
MEMORY FILES DELETED				

TX/RX NO	MODE	CONNECTION TEL/ID	PGS.	SET TIME	ST. TIME	SENDER NAME
0087	DELAYED TX	[ 01] ADAM BOOKS, CPA	1	01/01 16:05	00:30	R.LOUIS
0089	TRANSMIT	[ 01] ADAM BOOKS, CPA	3	01/01 16:31	-----	R.LOUIS
0092	MEM. BOX TX	[ 02] JOHN BARRISTER, ESQ	2	01/01 16:45	00:30	S.ROBERTS



# Chapter 15

## Maintenance & Frequently Asked Questions

---

This chapter shows you how to perform the routine tasks required to keep the fax unit operating at peak performance.

At the end of this chapter you are shown how to troubleshoot minor problems in response to error messages in reports or the LCD display.

Removing Document Feed Jams .....	15-2
Removing Printer Feed Jams .....	15-3
Storing Recording Paper .....	15-13
Recommended Paper .....	15-13
Storing the Paper Supply .....	15-13
Changing the Toner Cartridge .....	15-14
Storing Toner Cartridges .....	15-17
Handling Cartridges .....	15-17
Storing Cartridges .....	15-18
Periodic Cleaning .....	15-18
Cleaning the Fax Unit .....	15-18
Opening and Closing the Operation Panel .....	15-19
Cleaning the Scanning Area .....	15-22
Refilling the Stamp Ink Compartment (Option) .....	15-23
Error Code Table (listed by number) .....	15-24
List of LCD Display Messages (Alphabetic List) .....	15-26
Questions and Answers .....	15-30
Can not Send Documents Correctly? .....	15-30
Can not Receive Documents Correctly? .....	15-32
Can not Copy Documents? .....	15-34
Having Other Problems? .....	15-34
Recording the User Reminder Sheets .....	15-35

# Removing Document Feed Jams

To prevent frequent jams during document scanning, always check the pages before you feed them into the fax. (→6-2)

If a document is curled or wrinkled, make a copy of the original and scan the copy.

A message tells you when a document feed jam has occurred:

CHECK DOCUMENT



1. Press STOP.
2. Open the operation panel.

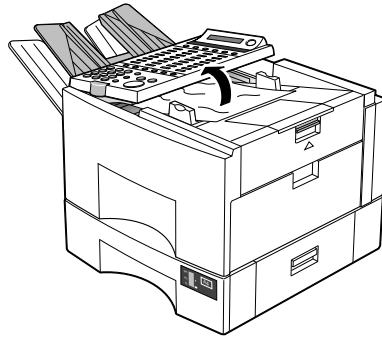

3. Pull the document straight forward or backward to remove it.

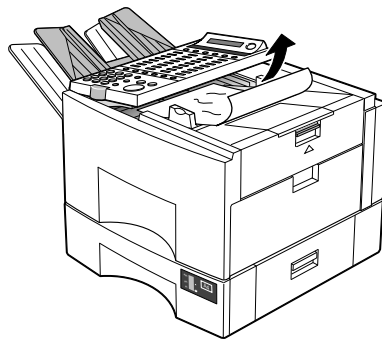

---

Always open the operation panel before you attempt to remove a jammed document.

---



4. Close the operation panel and press down on it gently until you hear it lock in place.

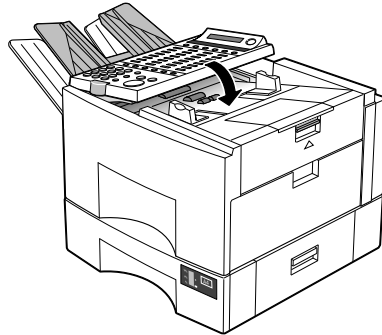

## Removing Printer Feed Jams

Observe these guidelines when you are inspecting the fax for printer feed jams:

- If the paper jam occurred as result of a power failure, restore power to the fax unit by re-connecting it to the power source before you follow the procedures below.
- Never attempt to remove a paper cassette when power to the fax unit is off.
- Make sure you check all the areas described below because paper jams can occur at more than one location.
- Follow the exact order of the steps below.
- When removing the paper cassettes, remove them gently.

When a recording paper jam occurs in the paper path, the fax displays a message:

REC. PAPER JAM



---

To avoid possible damage to the fax unit, never remove a paper cassette when the REC. PAPER JAM message is displayed before removing the paper jammed in the fax unit.

---



---

The fixing area becomes very hot. Do not touch any parts in the fixing area when you are removing a paper jam.

---

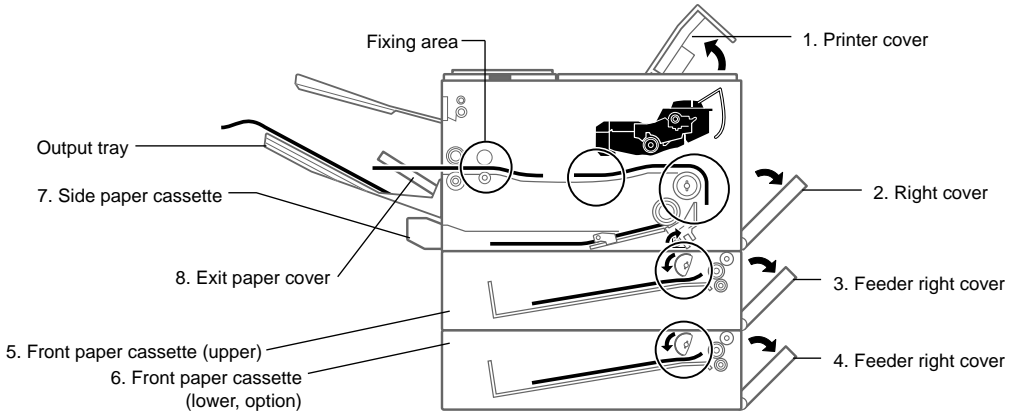

The additional FXL-CASSETTE FEEDER 5 is an option.

1. To remove the toner cartridge, pull up the lever above the ▲ mark on the printer cover.

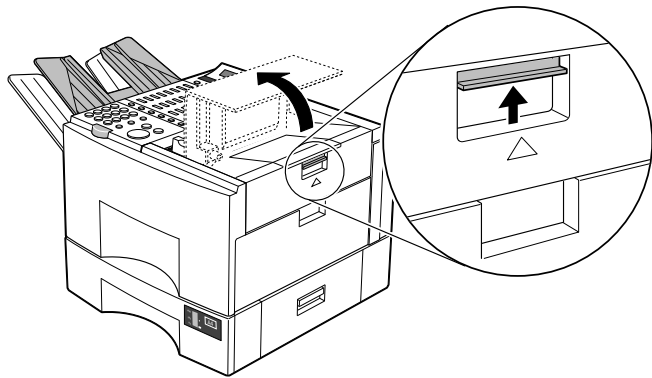

Raise the printer cover and remove the toner cartridge.

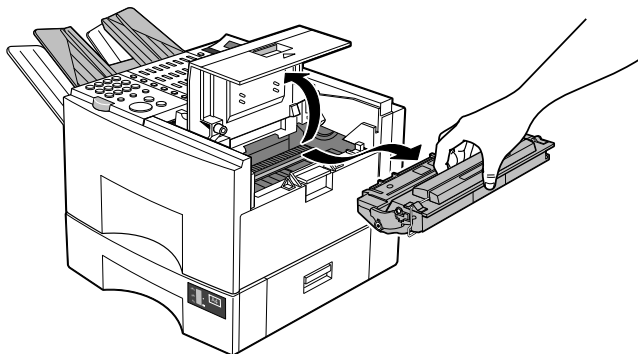



---

To protect the toner cartridge from light, insert it in the original bag you saved at installation, or wrap the toner cartridge in a cloth.

---

2. Open the right cover.

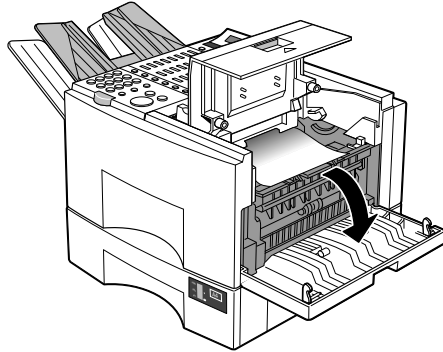

Check the toner cartridge compartment. If you see any paper in the toner cartridge compartment, remove it. While keeping the edge of the paper down, pull the jammed paper carefully forward to remove it.

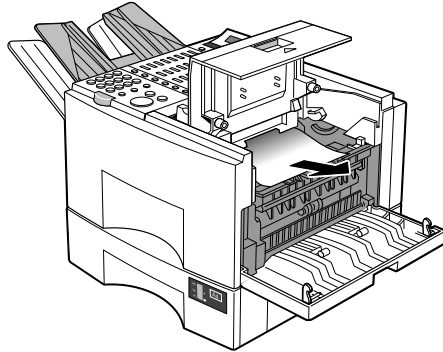

If the trailing edge of the jammed paper is under the cover, use both hands to pull the paper up. After the trailing edge is free, pull the jammed paper forward carefully to remove it.



---

Be careful not to make your hands dirty with the unfixed toner.

---

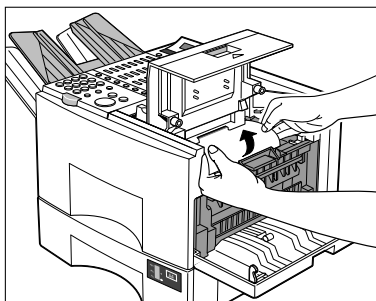

---

Avoid touching anything inside the fax.

---

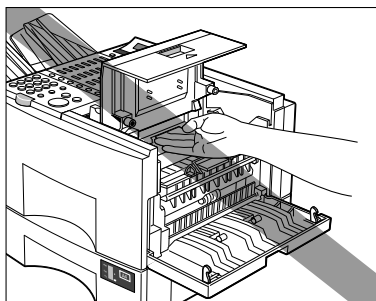

If you see any paper in this area, pull it in the direction indicated by the arrow.

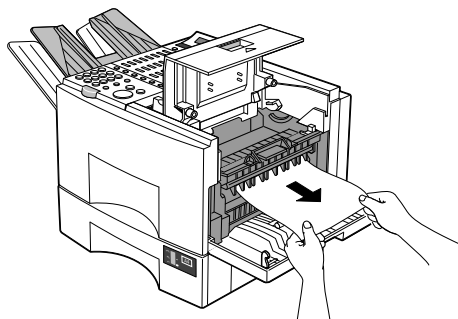



---

To avoid tearing the jammed paper, pull the paper straight down. Never pull it up or to the side.

---

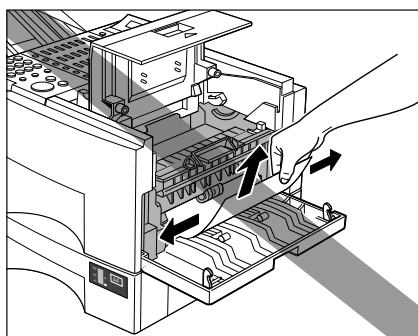

3. Open the feeder right cover of the front paper cassette. If you see any paper in this area, pull it out.

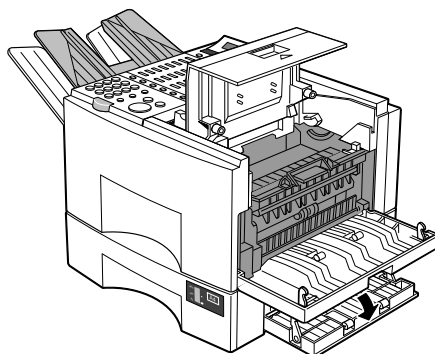

4. If you have the optional FXL-CASSETTE FEEDER 5 attached, open the lower feeder right cover. If you see any paper in this area, pull it out.

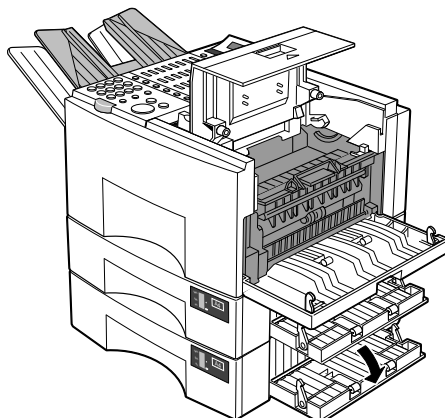

5. Pull out the front paper cassette.

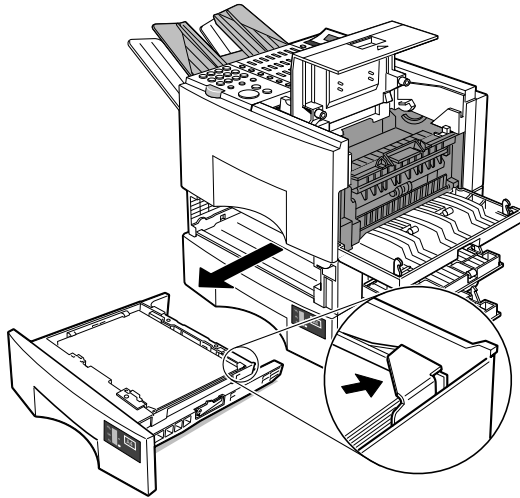

If you see any torn, curled, or wrinkled paper, remove it. Make sure the paper stack is below the tabs.

Make sure there is no paper left inside the fax.

6. If you have the optional FXL-CASSETTE FEEDER 5 attached, open and remove the lower front paper cassette.

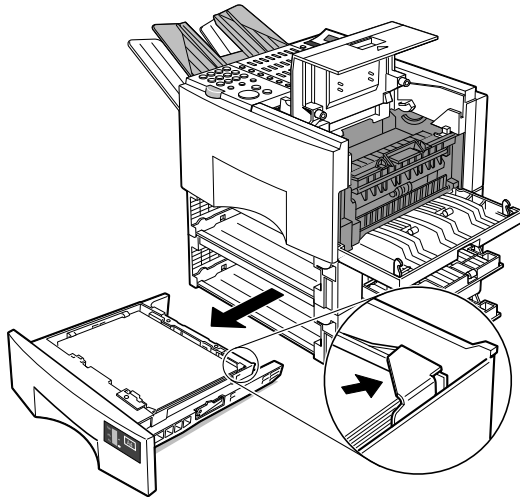

If you see any torn, curled, or wrinkled paper, remove it. Make sure the paper stack is below the tabs.

Make sure there is no paper left inside the fax.

7. Before you remove the side cassette, remove the output tray and document tray.

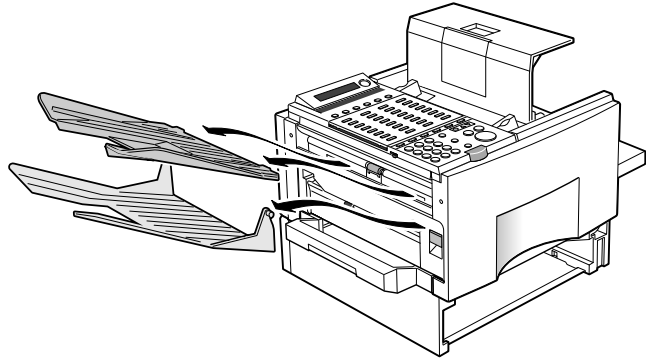

Remove the side paper cassette.

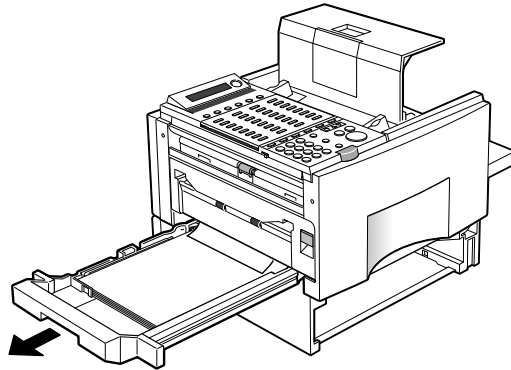

After you remove the side paper cassette, make sure no paper is hanging over the rear edge of the paper cassette.

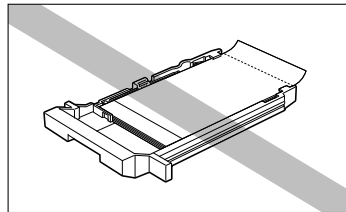

If you see any folded, torn, or curled paper, remove it.

Make sure there is no paper remaining inside the fax unit where you removed the cassette. If you see any paper inside the fax unit, remove it.

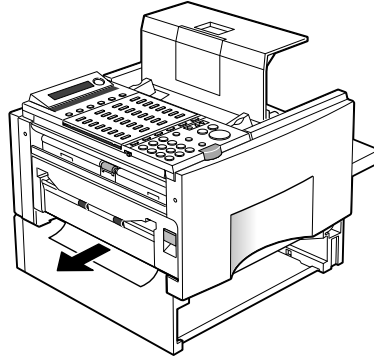

Check the side paper cassette selectors and make sure they are set for the type of paper loaded in the side paper cassette.

Make sure the stack of paper is firmly against the sides of the paper cassette and below the tabs.

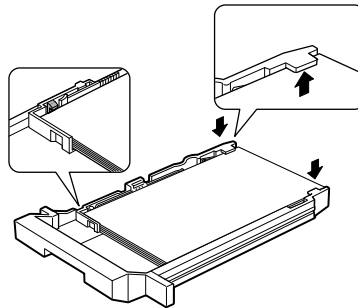

Then set the side paper cassette aside.



- To unlock and open the exit paper cover, pull up on the release button on the right side.

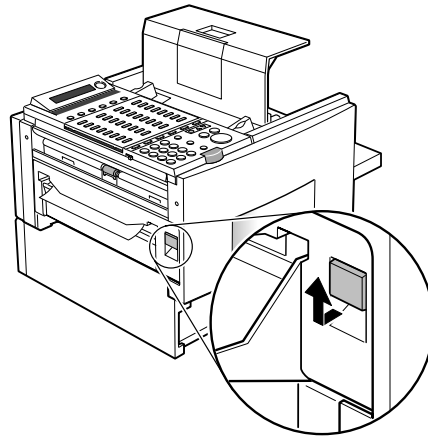

Lower the exit paper cover.

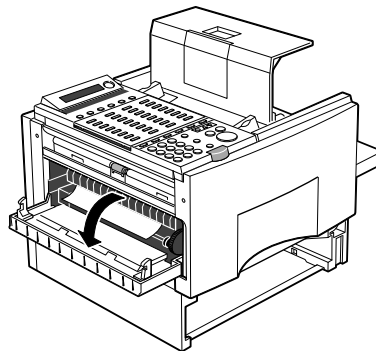

If you see any jammed paper in this area, pull the paper straight out to avoid tearing it.



---

Always gently pull the jammed paper straight out, never at an angle.

---

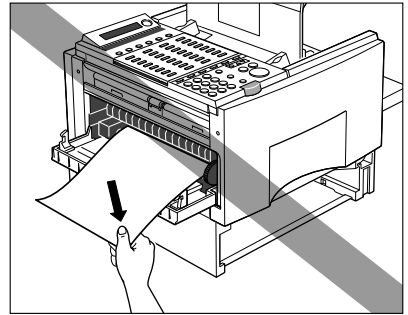
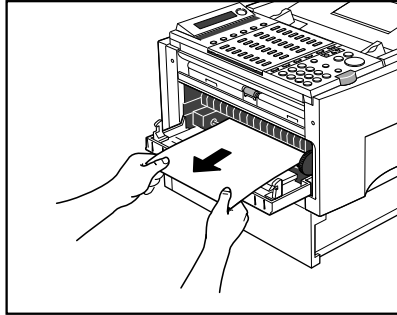

If the paper will not come out of the paper exit, push up on the pressure release button inside the paper exit, then pull the jammed paper straight out.

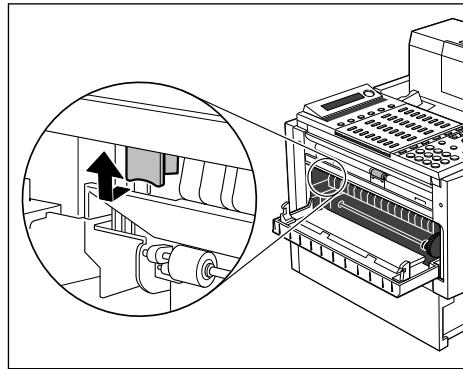

9. This concludes the procedure for checking the paper path for paper jams. Close all the covers and re-insert all the paper cassettes and trays.

# Storing Recording Paper

Use only the recommended paper or paper of similar quality, and store it carefully. When installing the recording paper, refer to page 2-25.

## Recommended Paper

We recommend using Canon paper with this fax machine.

---

Quality	Use plain bond, typewriter quality without curls, folds, or rough edges.
Weight	64-90 g/m <sup>2</sup>
Storage	18°C to 24°C 40%-60% relative humidity

---

- Before buying large quantities of other paper, test it with the fax to make sure it is reliable.
- Use only plain white paper. Do not use perforated or coloured paper.
- Paper that is either too smooth or rough may reduce print quality or cause printer jams.

## Storing the Paper Supply

Improper paper storage can affect the quality of the printing. Follow these guidelines when you store paper.

- Store unused paper in its wrapping to protect the paper against humidity.
- Do not store paper on the floor where humidity is higher.
- If the humidity of the surrounding area is higher than normal, store the paper in a specially designed storage box.
- To prevent excessive paper curl, do not stack paper too high.
- Do not expose the stored paper supply to direct sunlight.
- If paper is moved to a location of very different temperature, store the paper in the new location for at least one day before you use it.

# Changing the Toner Cartridge

CHANGE CARTRIDGE



When the toner runs low in the toner cartridge, the CHANGE CARTRIDGE indicator on the operation panel will light and you will see this message:

REPLACE CARTRIDGE



The fax may be set to continue printing or to store the remainder of a document being received into the memory.

You may be able to extend the service life of the toner cartridge by removing it and rotating it 5 or 6 times to re-distribute the toner inside the cartridge. After you re-set the cartridge in the fax unit, if the message goes off, you can continue printing but make sure you have a new cartridge on hand to replace the old one when it finally runs out of toner. If the message does not go off, then you will have to follow the procedure below to replace the old cartridge.

Follow this procedure to replace the toner cartridge.

1. Pull up the lever above the ▲ mark on the printer cover.

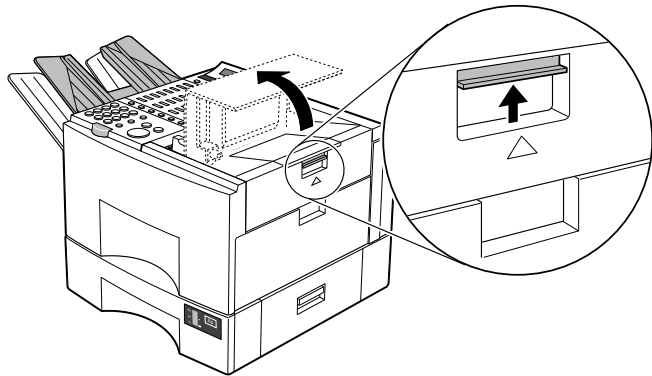

2. Raise the printer cover.

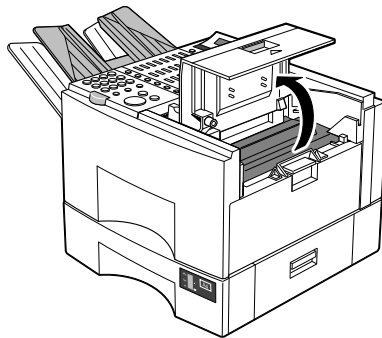

3. Remove the old cartridge and discard it. Do not attempt to disassemble the cartridge or refill the cartridge.



---

Do not incinerate the cartridge. Scattered toner powder is highly flammable.

---

**To dispose of the cartridge:**

To protect the environment, Canon has started a special program to help you dispose of your empty toner cartridges.

After you install a toner cartridge, keep the original packing material. Depending on the country of purchase, you may be able to have your empty toner cartridge picked up for disposal at Canon's expense. For details about this special program to protect the environment, contact your local Canon supplier or sales representative.

4. Remove a new toner cartridge from its protective bag. Hold the cartridge by the ends and avoid touching the top and bottom of the cartridge.



---

Save the protective bag. You may need it to transport the cartridge later.

---

5. Rock the new cartridge five or six times to distribute the toner evenly inside the cartridge.

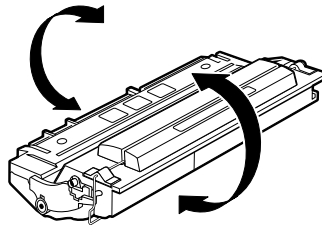

6. Place the cartridge on a flat, clean surface.

7. As you steady the cartridge with one hand, remove the seal by gently pulling the plastic tab with your other hand.

Use a firm, even pull to avoid breaking the seal.

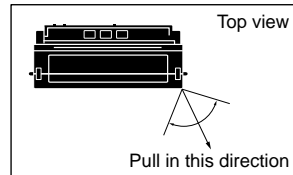
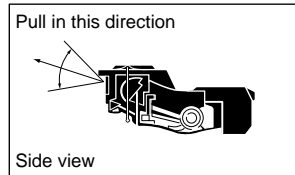
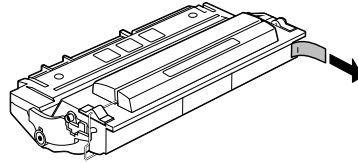

8. To avoid pinching your fingers between the toner cartridge and fax unit, grip the cartridge as shown below.

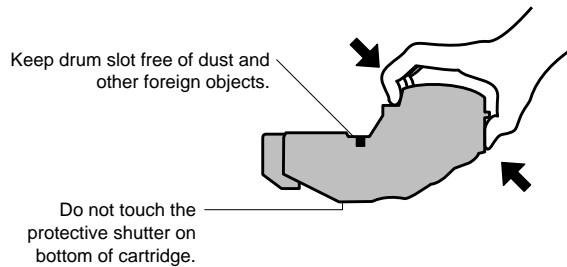

9. Load the cartridge in the direction indicated by the arrow. Gently slide the cartridge into the printer until it is completely down inside the fax unit and level.

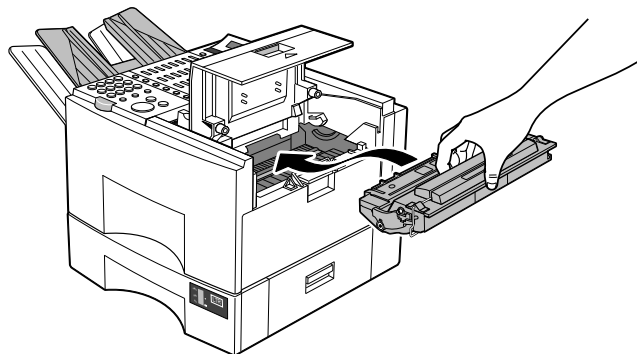

10. Carefully close the printer cover and make sure it is locked.

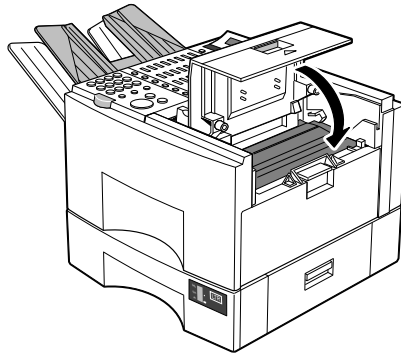

- If the printer cover does not shut completely, do not force it down. Remove the toner cartridge and insert it again.
- To avoid exposing the light sensitive drum, never leave the printer cover open.
- The fax unit will not operate if the cover is not closed completely. If the printer cover is open you will see a message:

CHECK PRINTER COVER

Open the printer cover again and make sure the toner cartridge is sitting level and close the printer cover again.

## ***Storing Toner Cartridges***

Follow these simple guidelines when you handle and store toner cartridges.

### ***Handling Cartridges***

- Do not remove the toner cartridge from its protective bag until you are ready to install it.
- Save the protective bag. You may need it later to re-pack the cartridge temporarily to protect it from exposure to light.
- Never expose a toner cartridge to direct sunlight, and do not leave it exposed to normal room light (about 1,000 lux) for longer than 5 minutes.
- There are strong magnets inside a toner cartridge. To avoid possible destruction of valuable data on disks or other media, keep the toner cartridge away from computer screens, hard disks, floppy disks, or any other kind of material sensitive to magnetic fields.

- Never touch or try to open the protective shutter that protects the light-sensitive drum inside the toner cartridge. If the drum is exposed to light, this can cause printing quality to deteriorate.
- Handle the toner cartridge with care. Do not subject it to shock or vibrations.
- Always set toner cartridges down with the arrow on the cartridge facing up.

## ***Storing Cartridges***

- Store a toner cartridge in the original box and protective bag until you are ready to install it.
- Store toner cartridges at a constant temperature within a range of 0°C to 35°C. Do not store cartridges in places subject to extreme fluctuation of temperature or humidity.
- To prevent caking in the toner, never stand the cartridge on its end and do not store it upside down. If the toner becomes caked as a result of being stored in an odd position for too long, it may be impossible to dissolve it completely even by shaking the cartridge.
- Do not store the cartridge in salty or corrosive air.
- Never attempt to disassemble a toner cartridge or attempt to refill it.
- Make sure that you use a stored toner cartridge before the expiration date printed on the toner cartridge box.

## ***Periodic Cleaning***

Follow these simple procedures to keep the fax clean and operating smoothly. Before you clean the fax, print all documents received in the memory.

### ***Cleaning the Fax Unit***

1. Before you clean the fax, disconnect the power cord of the fax unit from the power source.



2. Moisten a soft cloth with water and a small amount of diluted mild detergent.

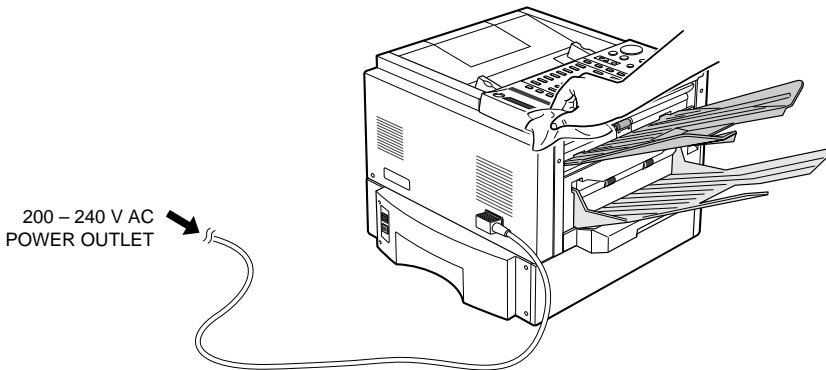

---

To prevent damage to the surface of the fax unit, never use thinner, benzene, alcohol, acetone, or any other organic solvent to clean the fax.

---

## ***Opening and Closing the Operation Panel***

Follow this procedure to open and close the operation panel in order to clean the scanning glass or to re-fill the stamp ink (option).

### ***Opening the Operation Panel***

Follow this procedure to open and close the operation panel in order to clean the scanning glass or to re-fill the ink pad for the stamp feature.

1. Disconnect the power cord of the fax unit at the power source.
2. Remove the document tray.

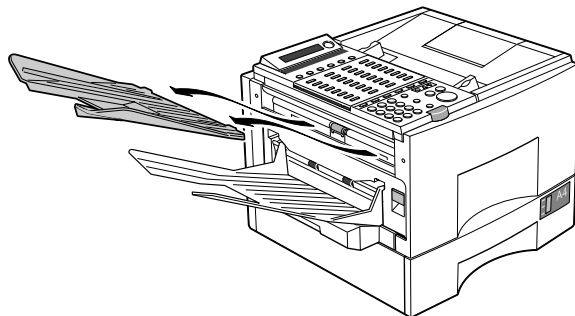

3. Lift the operation panel up until it stops.

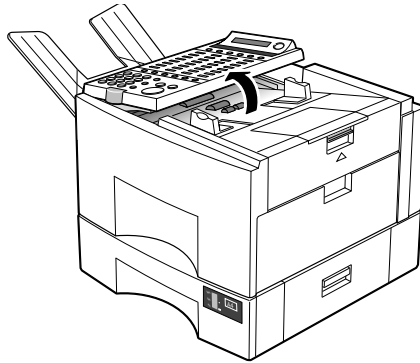

4. While holding the operation panel open with one hand, use one finger of your other hand to gently push in the black plastic loop to separate it from the stub on the fax machine.

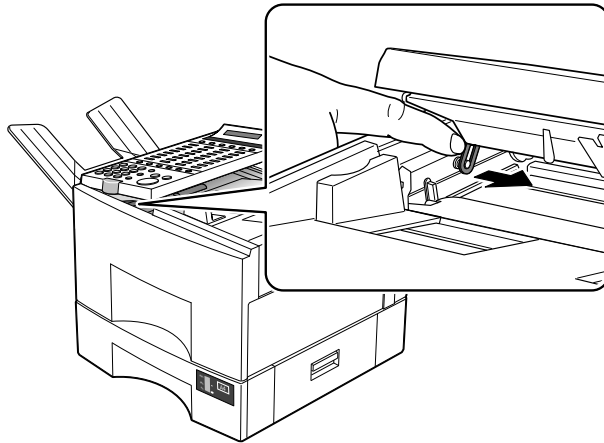

5. Lift the operation panel up to the open position.

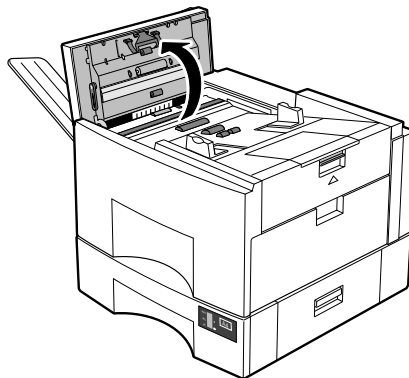

6. You can now clean the scanning glass. (→15-22)

-or-

Re-fill the stamp pad. (→15-23)

### ***Closing the Operation Panel***

1. Lower the operation panel until the plastic loop is even with the stub on the fax machine.
2. Place the end of the plastic loop over the end of the stub so it locks in place.

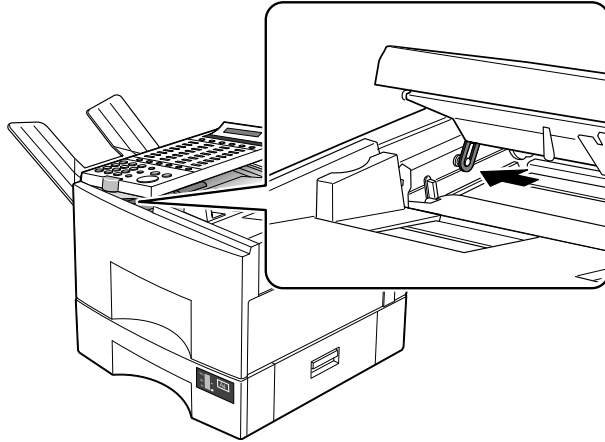

3. Close the operation panel and press down on it slightly until you hear it lock in place.
4. Re-attach the document tray you removed earlier.
5. Connect the power cord of the fax unit at the power source.

## Cleaning the Scanning Area

Periodically check the scanning glass, the white scanning strip, and rollers. If the underside of the operation panel or the scanning glass is dirty, the documents you send will look dirty.

1. Disconnect the power cord of the fax unit from its power source and remove the document tray and open the operation panel. (→15-19)

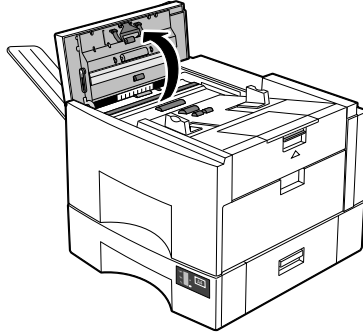

2. Use a soft, dry cloth to wipe clean the scanning glass, the white strip above, rollers and the area around the glass. Use a soft cloth that will not scratch the scanning glass.

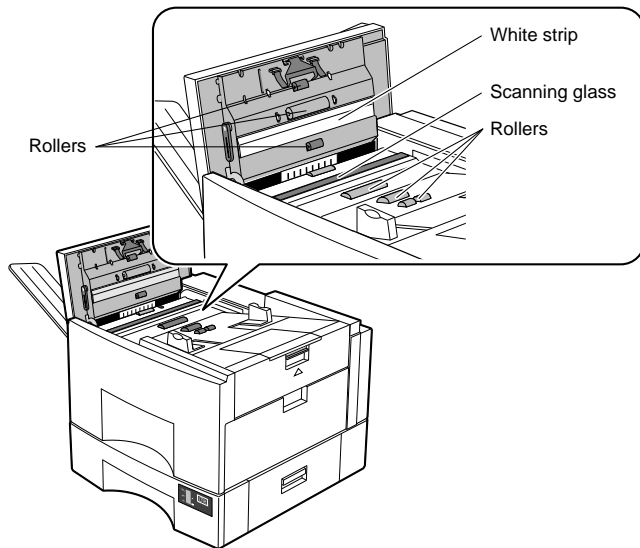

- Use the dry cloth to wipe clean the underside of the operation panel.
- Use the dry cloth to wipe up paper dust around the rollers.

3. Close the operation panel, re-attach the document tray and connect the power cord of the fax unit to the power source. (→15-21)

## ***Refilling the Stamp Ink Compartment (Option)***

Follow this procedure to refill the stamp ink compartment if you are using the optional stamp feature.

1. Disconnect the power cord of the fax unit from its power source, remove the document tray, and open the operation panel. (→15-19)

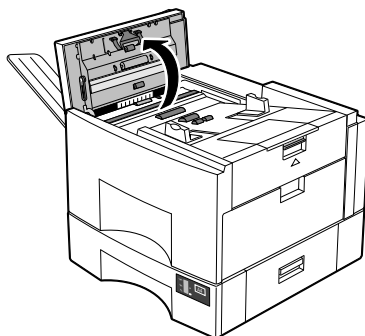

2. Locate the stamp pad then apply only one drop of ink to the stamp ink compartment.
  - To avoid a malfunction, do not add too much ink.
  - Use only Shachihata X Stamper Ink CS-20 Yellow.
  - Do not use the stamp feature for at least one hour. If you have to send a document, turn off the stamp feature for the first hour. (→16-11)

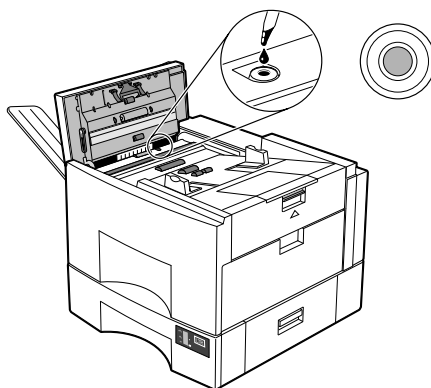

---

To avoid ink spillage, apply only one drop of ink to the stamp pad.

---

- Close the operation panel, re-attach the document tray and connect the power cord of the fax unit to the power source. (→12-10)



Make sure that you do not drip ink on any other part of the fax, and do not fill the ink well so it overflows.

## Error Code Table (listed by number)

Errors in reports are recorded as numbers because there is not enough space to print a detailed description of the error in the report. When errors are recorded in your reports, note the number and check it against the table below to learn more about what caused the error.

CODE	PROBLEM	SOLUTION
#001	A document may be jammed in the automatic document feeder (ADF).	Remove the jammed document and try again. (→15-2)
#003	The document is longer than 1 meter.	Make a reduced copy of the document with a copy machine and then send the copy, or cut the document and paste it up on smaller sheets of paper. (→B-2)
#005	The other party's fax did not respond within 35 seconds.	Send the document again. Contact the other party and have them check their fax. You can try to send the document manually. For an overseas call, add pauses to the registered number.
	The other party is not using a G3 fax.	Check with the other party and have them send or receive the document using a G3 machine.
#008	You can not do polling sending.	Make sure the subaddress/passwords match the settings on the other party's fax unit. If the other party's fax is Canon fax and can set a polling ID, request that they set the polling ID to 255 decimal or 1111 1111 binary.
#009	The paper cassette on your fax is out of paper.	Re-fill the paper cassette and make sure the stack is below the tabs. (→2-22)
	If the paper cassette still has paper in it, then the paper cassette may not be installed correctly.	Check all paper cassettes and make sure they are installed correctly.
	Recording paper jammed.	Remove the jammed paper. (→15-3)
#011	If you are polling a fax to receive a document, the other party has not set the document correctly on the other fax.	Contact the other party and request that the document be set correctly for polling on the other fax.
#012	The other fax has run out of paper and its memory is full.	Contact the other party and tell them to re-fill their paper cassette.

<b>CODE</b>	<b>PROBLEM</b>	<b>SOLUTION</b>
#018	The other fax does not answer, even after several redialling attempts, or the other fax was busy and unable to respond within 35 seconds.	Wait a few minutes and try again. If you still can not send the document, contact the other party and confirm that the other fax has been turned on. If the other fax is busy, try sending your document at a later time. When you send documents long distance, open both One-touch Speed Dialling panels and press PAUSE after dialling. (→6-9)
#021	You can not be polling receiving.	Make sure the subaddress/passwords match the settings on the other party's fax unit. If the other party's fax is a Canon fax and can set a polling ID, request that they set the polling ID to 255 decimal or 1111 1111 binary.
#022	The settings for the One-touch or Coded Speed dialling buttons you are using to dial the other party have been deleted.	Correct the One-touch or Coded Speed dial registration settings. (→4-6, 4-14)
#025	During registration of the number for One-touch or Coded Speed Dialling, you registered the number for confidential or relay sending but you omitted the subaddress.	Open the optional settings for One-touch or Coded Speed Dialling and make sure that you have entered a subaddress and password (if required) for the telephone number. (→4-6, 4-14)
	After setting up relay sending or confidential sending, the settings for One-touch or Coded Speed dialling may have been changed.	Open the settings for One-touch or Coded Speed Dialling and make sure the settings have not been changed. (→4-6, 4-14)
#033	You have attempted to send a confidential document to a fax unit that does not support the use of ITU-T subaddresses.	Send the document without confidential settings, or send the document to a fax that supports the use of ITU-T subaddresses.
#034	You sent a confidential document to another fax unit but it was rejected.	Contact the other party and confirm the settings on the other party's confidential mailbox.
#035	You have attempted to relay a document to a fax unit that does not support the use of ITU-T subaddresses.	Send the document by regular transmission.
#036	You have attempted to relay a document to a fax unit but it was rejected.	Contact the other party and confirm that their relay settings match the relay settings on your fax unit.
#037	The memory in your fax is full and can not store a document for sending or receiving.	Before you try to clear the memory, you may want to print a memory list for reference. (→8-4) If there are documents in the memory that you do not need, erase those documents from the memory. (→8-8)
#059	The number you had dialled did not match with the registered number on the other party's fax. The number is not registered on the other party's fax or the number registered on the other party's fax is not correct.	Call the other party and ask the other party to register the number or to correct the number. Or, set PHONE NO. CHECK of the system setting to OFF on your fax. (→16-26)

<b>CODE</b>	<b>PROBLEM</b>	<b>SOLUTION</b>
#080	The other party's fax does not support receiving a document with a subaddress.	Call the other party and confirm whether or not their fax supports subaddress receiving. Try sending again without a subaddress.
#081	The other party's fax does not support receiving a document with an ITU-T password.	Call the other party and confirm whether or not their fax supports ITU-T password receiving. Try sending again without a password.
#082	The other party's fax does not support accepting a polling request with a subaddress.	Call the other party and confirm whether or not their fax can accept a polling request with a subaddress. Try sending again without a subaddress.
#083	You can not poll the other party to receive a document because a subaddress and/or password does not match.	Call the other party and confirm that the subaddress and/or password that you are using are correct.
#084	The other party can not receive a document with an ITU-T password.	Call the other party and confirm whether or not the other party's fax supports receiving a polling request with an ITU-T password. Ask the other party to try again without an ITU-T password.
#102	You can not receive documents because a subaddress and/or password does not match.	Call the other party and confirm whether or not you are using the correct subaddress and/or password.
#995	Documents in the memory to be sent have been cleared.	The current transmission has been cleared. You may start again, start a new operation, or leave the fax in standby.

## **List of LCD Display Messages (Alphabetic List)**

Here is a list of messages that are displayed on the screen when a problem occurs in the fax or the printer.

<b>MESSAGE</b>	<b>WHAT IT MEANS</b>
#ALREADY IN USE	The box number you entered is already in use. For example, you can not use the same box number for a confidential mailbox and a polling box. Try again with another box number.
AUTO REDIAL	The other party's line was busy on the previous dialling attempt and your fax unit is dialling the number again. To cancel redialling, press STOP when direct dialling or press DELETE FILE, select transaction number then press SET when memory sending.
BUSY/NO SIGNAL	The other party did not answer, even after redialling. Wait for a few minutes and try again. When you send documents long distance, press PAUSE after dialling. If you still can not send the document, the other party may have turned off their fax unit.



<b>MESSAGE</b>	<b>WHAT IT MEANS</b>
CHECK DOCUMENT	A document page may be jammed or may not be fed correctly in the automatic document feeder (ADF). Remove the document and try again. (→15-2) If the document does not feed correctly, clean the rollers. (→15-22)
CHECK POLLING ID	Your attempt at polling receiving failed. The polling ID may be incorrect or your subaddress/password does not match the subaddress/password set on the polling box of the other party's fax unit. Contact the other party and make sure you are using the correct polling ID or subaddress/password. (→11-3)
CHECK PRINTER	Printer malfunction. Press STOP. Unplug the fax unit from its power source, wait a few minutes, then plug in power cord again. If the fax is connected to an uninterruptable power supply (UPS), unplug the power cord, and then plug it into an AC outlet. If message remains in the LCD display and the fax unit can not return to standby, call for service.
CHECK PRINTER COVER	Check the printer cover, right cover, and exit cover and make sure that they are completely closed. Make sure a toner cartridge is installed under the printer cover.
CHECK SUBADDR/PASSWD	You attempted sending or polling receiving with an incorrect subaddress/password. Contact the other party and confirm that you are using the correct subaddress/password.
COMMUNICATING PLEASE WAIT	You tried to use direct sending while the fax was sending another document. Wait until the transmission is finished, then try again.
DOCUMENT TOO LONG	The document is longer than 1 meter. Cut the document into smaller sheets. Reduce them on a copy machine if necessary. Then paste them on standard letter or A4-size sheets for scanning.
HANG UP PHONE	The transaction has completed but the handset is not sitting completely on its cradle. Make sure the handset is sitting completely on its cradle.
MEMORY FULL	The memory is full. If the document has been received in the memory, print the document. (→8-2)
	If documents have been received in confidential mailboxes, print them. (→10-7)
	If documents have been received in memory boxes, print them. (→8-23)
	Check the content of the memory and if there are documents in the memory that you do not need, delete them from the memory. (→8-8)
	If you tried to send a document with "SUPER FINE" or "TEXT/PHOTO", try sending by direct sending, or set to "FINE" or "TEXT" and send by memory sending.
MEMORY FULL PLEASE WAIT	The memory is full. Wait until the current document transmission has completed.
NO ANSWER	The other party did not answer. Start the procedure again from the beginning and try again. If the connection fails again, make sure the other party is using a G3-compatible fax machine.

MESSAGE	WHAT IT MEANS
NO CONFID. TX	The other party's fax unit may not support the use of confidential mailboxes. Contact the other party and confirm whether or not they can set up confidential mailboxes.
	You may be using the wrong ITU-T subaddress/password. Contact the other party and make sure you are using the correct subaddress/password.
	The memory of the other party's fax unit may be full. Contact the other party and request that they clear the memory on their fax unit.
NO DOC. STORED	You have tried to check the contents of the memory but no documents are currently stored in the memory.
NO ORIGINAL RELAY TX	The other party's fax unit may not be able to function as a relay station, or it may not be set up correctly to receive and relay documents. Contact the other party and make sure it can function as a relay station.
	If the fax unit can be set up as relay station, confirm that it is set up correctly for relay transmissions. Make sure you have both registered the same ITU-T subaddress/password.
	If the memory of the other party's fax unit is full, it will not be able to receive and relay documents. Ask them to clear part or all of the memory on their fax unit.
NO RX PAPER	The other party's fax unit has run out of paper and can not receive your document. Contact the other party and ask them to re-supply recording paper to their fax unit.
NO TEL#	You have pressed a One-touch Speed Dialling button, or pressed CODED DIAL followed by a 3-digit code, but no telephone number is registered. If you have forgotten where the number is registered, use directory dial. (→4-31) You can also print a list of all numbers registered for speed dialling. (→14-2)
NOT AVAILABLE NOW	You pressed a One-touch Speed Dialling, or pressed CODED DIAL followed by a 3-digit code, that is not registered for the feature you are trying to use.
NOT FOUND,TRY AGAIN	The box number you specified does not exist. Try again with a different number.
PASSWORD POLL REJECT	You set up a polling box for polling sending with an ITU-T password, but the other party's fax unit does not support use of an ITU-T password for polling receiving.
PASSWORD TX REJECT	You attempted to send a document with an ITU-T password, but the other party's fax unit does not support use of an ITU-T password for receiving.
PRT ALT. PAPER SIZE? YES=(*) NO=(#)	The size of the available recording paper does not match the size of the document waiting to be printed. If you do not mind printing on a different paper size, press *. If you want to print the correct paper size, press STOP and install the correct size paper. Then press START/SCAN.
REC. PAPER JAM	Paper has jammed in the paper cassette or inside the printer. Clear the paper jam. (→15-3)

<b>MESSAGE</b>	<b>WHAT IT MEANS</b>
RECEIVED IN MAILBOX	A confidential document has arrived in a mailbox of your fax unit, and the message will remain displayed until you print the document. (→10-8)
RECEIVED IN MEMORY	The fax unit has run out of recording paper or the toner supply of the toner cartridge is exhausted. Supply paper to the paper cassettes or change the toner cartridge. As soon as you accomplish this task, the document prints automatically. (→8-2)
RECEIVED IN MEM. BOX	You have received a document in a memory box. Print out the document in the memory box. (→8-23)
REPLACE CARTRIDGE	The toner cartridge has run out of toner. Replace the toner cartridge. (→15-14)
USER ACCESS CODE	You have to enter user access code to send, copy or print reports.
ENTER DAC	You have to enter department access code to send document.
SELECTIVE POLL REJECT	You have set up a polling box for polling sending with an ITU-T subaddress, but the other party's fax unit does not support use of an ITU-T subaddress for polling receiving.
START AGAIN	An error has occurred on the telephone line or in your fax unit. Start the procedure from the beginning. If the problem persists, call for service.
STOP KEY PRESSED	You have pressed the STOP button to cancel the current transaction. The fax unit should return to standby in a few moments.
SUBADDRESS TX REJECT	You attempted to send a document with an ITU-T subaddress, but the other party's fax unit does not support receiving a document with an ITU-T subaddress.
SUPPLY REC. PAPER	Your fax unit has run out of paper. Re-fill the paper cassettes. (→2-22)
USER ACCESS LOCK	Sending or printing have been restricted. Set the TX SETTING or PRINTER SETTING of the restrictive codes to OFF. (→13-12)

# Questions and Answers

## Can not Send Documents Correctly?

- **Can not send after dialling?**
  - Is the document set in the automatic document feeder (ADF) correctly?**

Remove the document and set it correctly. (→6-2, 15-2)
  - Is the number dialling correctly?**

Check the number registered for the speed dialling button and make sure it is correct. You may want to print a list of all registered speed dialling buttons. (→14-2) If you do not have time to check and correct the registration immediately, use regular dialling. (→6-7)
  - Is the other fax out of paper?**

Call the other party and make sure their fax is supplied with paper.
  - Are the rollers dirty?**

Clean the rollers. (→15-22)
- **Does memory fill up immediately when you try to send?**
  - Are the document mode settings on?**

The FINE, SUPER FINE, or TEXT/PHOTO settings can use large amounts of memory when scanning certain types of documents. Use direct sending. (→6-13)
- **Are documents streaked with lines after they print on the other fax?**
  - Is the scanning glass on your fax clean?**

Copy a document on your fax and see if the copy is streaked or dirty. If the print is streaked, clean the scanning glass. (→15-22)
- **Are your documents printing at a reduced size on the other fax?**
  - Are the document feed guides set properly when you scan documents for sending?**

Make sure the document feed guides are snug against the side of the document you scan for sending. (→6-3)
- **Are the documents you send too light?**
  - Is the LIGHTER indicator on your operation panel on?**

Press the CONTRAST button until STANDARD or DARKER is selected. (→6-4)

**Is your document too light?**

Press the CONTRAST button until DARKER is selected then try sending again. (→6-4)

**Is the scanning glass on your fax clean?**

Copy a document on your fax and see if the copy is streaked or dirty. If the copy is streaked or dirty, clean the scanning glass. (→15-22)

■ **Can not perform relay sending?**

**Does the relay unit support ITU-T subaddress/password transactions?**

If the relay unit does not support ITU-T subaddress/password transactions, you can not perform relay sending.

**Has the relay unit set up a relay group correctly?**

The relay group must be set up correctly on the relay unit and the relay unit must tell you the subaddress and password. If the relay unit has set a ITU-T password, then you must send the document with the correct password as well as the correct subaddress. (→9-8)

**Does the ITU-T subaddress/password match those of the relay unit?**

Make sure you set the correct subaddress/password. (→9-9)

**Is the memory of the relay unit full?**

Check with the relay unit and make sure there is enough memory to receive your document. Ask the relay unit to clear their memory then try again.

■ **Can not perform confidential sending?**

**Does the other fax support ITU-T subaddress/password transactions?**

If the other fax does not support ITU-T subaddress/password transactions, you can not perform confidential sending.

**Has the other party set up a confidential mailbox?**

The other party must set up a confidential mailbox on the other fax and tell you the subaddress and password. If the other party has set a ITU-T password, then you must send the document with the correct password as well as the correct subaddress. (→10-9)

**Does the ITU-T subaddress/password match those of the other party?**

Make sure you set the correct subaddress/password. (→10-9)

**Is the memory of the other fax full?**

Check with the other party and make sure there is enough memory to receive your document. Ask the other party to clear their memory then try again.

■ **Can not relay a document from another fax?**

**Does the other fax unit support subaddress/password transactions?**

If the other party's fax does not support subaddress/password transactions, you can not relay documents.

Make sure you have both registered the same ITU-T subaddress/password. (→9-2)

**Is your fax set up to relay documents?**

Make sure your fax is set up properly to relay documents. The relay feature must be turned on. (→9-3)

**Does the other party's fax support ITU-T subaddresses and passwords?**

Contact the other party and confirm that they called you with the correct subaddress/password.

**Are the originator's subaddress/password correct?**

The originator must send you the document with the correct ITU-T subaddress/password.

The ITU-T password setting is optional. However, if you set a password on your relay TX group then the originator must send a password. Otherwise, your fax will not receive the document for relay broadcasting. (→9-3)

Check the relay TX group and determine if it has been set to check the identity of the originator before it receives the document for a relay broadcast. (→9-6)

■ **Other party can not poll and receive your document?**

**Does the other party's fax support ITU-T subaddress/password sending?**

If the other party's fax does not support ITU-T subaddress/password, you have to make a polling box #00 for the other party and scan the document without subaddress/password. (→11-13) If the other party's fax is a Canon fax and can set a polling ID, ask them to set the polling ID for 255 decimal or 1111 1111 binary.

## **Can not Receive Documents Correctly?**

■ **Can not receive documents automatically?**

**Is the MANUAL RX indicator on your operation panel on?**

If this indicator is on, press the button below MANUAL RX to turn it off. (→7-2)

■ **Can not receive manually?**

**Is there a document set in the automatic document feeder (ADF)?**

You can not receive with a document set in the automatic document feeder (ADF). Remove the document and try again. (→15-2)

**Did you press START/SCAN before you hung up the handset?**

When you hear a high pitched tone, press START/SCAN before you hang up the handset. Review the procedure for manual receiving with the optional handset kit installed on the fax. (→7-7)

■ **Are the documents you receive of poor quality?**

**Is your toner cartridge running low on toner?**

Remove your toner cartridge and rotate it 5 or 6 times to evenly distribute the remaining toner and try again. If this does not solve the problem, you should change the toner cartridge. (→15-14)

**Is the other fax functioning properly?**

The sending fax usually determines image quality. Try copying a document on your own fax. If the copy is clean then the other fax has a problem. Call the other party and ask them to clean the scanning glass on the other fax.

■ **Can not receive a confidential document in your confidential mailbox?**

**Does the other party's fax support subaddress/password transactions?**

If the other party's fax does not support subaddress/password transactions, you can not receive confidential documents.

Make sure the other party knows the correct subaddress/password for your confidential mailbox.

■ **Can not poll another fax and receive its document?**

**Are you polling without a subaddress/password?**

If the other party's fax is a Canon fax and can set a polling ID, ask them to set the polling ID for 255 decimal or 1111 1111 binary.

**Are you polling with a subaddress or password?**

Contact the other party and confirm that their fax supports receiving a polling request with a subaddress or password.

If the other party's fax supports subaddress/password polling, confirm that you are using the correct subaddress and password.

If the other party's fax does not support subaddress/password polling, call the other party without subaddress/password. (→11-3)

## **Can not Copy Documents?**

- **Can not copy?**  
**Is the toner cartridge out of toner?**  
Change the toner cartridge. (→15-14)
- **Is the copied document reduced?**  
**Are the document feed guides snug against the sides of the document that you are copying?**  
Make sure the document feed guides are both against the sides of the document in the automatic document feeder (ADF) before you start copying. (→5-3)
- **Are copied document cut at the margins?**  
**Are the document guides on the side paper cassette set for the width of the paper loaded in the cassette?**  
Adjust the document guides to the width of the paper loaded in the paper cassette. (→2-22)

## **Having Other Problems?**

- **Is sending and receiving documents too slow?**  
**When sending, is the document mode set for SUPER FINE, FINE, or TEXT/PHOTO?**  
If the indicator for SUPER FINE, FINE, or TEXT/PHOTO is on, press RESOLUTION to select STANDARD, or press DOCUMENT TYPE to select TEXT. (→6-4)
- **Is your fax set for ECM receiving or sending?**  
Because the fax is constantly checking for errors during transmission, ECM receiving and sending require more time. The fax is set to conduct all transactions using ECM (error correction mode). If transmission speed appears to be extremely slow, you may be able to speed up transmission time by turning ECM off. (→16-9, 16-12)
- **Can not get faxes from information services?**  
**Is your fax connected to a rotary dial telephone line?**  
Even if your fax is connected to a rotary dial line, you can still get faxes from information services that require tone dialling. Press TONE to receive faxes from information services that require touch-tone telephone lines for transmission. (→12-3)



# Recording the User Reminder Sheets

The user reminder sheets are essential for recording the passwords, box numbers, subaddresses, and so on, so you do not forget them. We recommend that you make a copy of these sheets, fill them out, and use them for reference.

After you fill out these reminder sheets, store them in a safe place to protect their confidentiality and so you can find them later for reference.

## Password Reminder

<b>Item</b>	<b>Description</b>	<b>Password (four-digit)</b>
System Settings	Protects the user data System Settings from unauthorized access.	
Sending Restrictions	Restricts document sending to holders of the User Access Code.	
Printing Restrictions	Restricts report printing and document copying.	
Memory Reception	Protects your MEMORY RECEPTION button setup from unauthorized access.	
Transfer	Protects your TRANSFER button setup from unauthorized access.	

**Department Access Code**

<b>Dept. Access Code (four-digit)</b>	<b>Password (four-digit)</b>	<b>Dept. Access Code (four-digit)</b>	<b>Password (four-digit)</b>

**Preset Polling**

<b>Box No. (two-digit)</b>	<b>Box Name</b>	<b>Password (four-digit)</b>

**Confidential Mailboxes**

<b>Box No. (two-digit)</b>	<b>Box Name</b>	<b>Password (four-digit)</b>	<b>Subaddress (Max. 20-digit)</b>	<b>RX Password (Max. 20-digit)</b>

**Relay Broadcast Groups**

<b>Group No. (two-digit)</b>	<b>Group Name</b>	<b>Password (four-digit)</b>	<b>Subaddress (Max. 20-digit)</b>	<b>RX Password (Max. 20-digit)</b>

### Memory Boxes

Box No. (two-digit)	Box Name	Password (four-digit)	Subaddress (Max. 20-digit)	TX Password (Max. 20-digit)	RX Password (Max. 20-digit)

### Polling Boxes

Box No. (two-digit)	Box Name	Password (four-digit)	Subaddress (Max. 20-digit)	TX Password (Max. 20-digit)

# Chapter 16

## Summary of Important Settings

---

This chapter contains a comprehensive list of all the settings you can perform with the DATA REGISTRATION Menus.

The settings that determine how the fax unit operates are called user data settings. These important settings can be switched on and off to customize operation of the fax unit.

Opening the Data Registration Menu .....	16-2
Summary of User Data Settings .....	16-3
User Settings .....	16-4
Report Settings .....	16-7
TX (Send) Settings .....	16-9
RX (Receive) Settings .....	16-12
Printer Settings .....	16-14
File Settings .....	16-17
System Settings .....	16-23
Relationship between BATCH TX, QUICK ON-LINE TX, and Timer Settings .....	16-27

# Opening the Data Registration Menu

Follow this procedure to display the user data settings.



DATA REGISTRATION



SET



1. Open both One-touch Speed Dialling panels. Then press DATA REGISTRATION.

```
REGISTRATION
1.DATA REGISTRATION
```

2. Press SET to display the next menu.

```
DATA REGISTRATION
1.USER SETTINGS
```

3. Use the search buttons to display the item you want to set or change.

```
DATA REGISTRATION
1.USER SETTINGS
```

```
DATA REGISTRATION
7.SYSTEM SETTINGS
```



4. Display the item you want to set or change and press SET. For details, refer to the following section.

The user data menu selections are displayed one line at a time. Use the search buttons to display these settings so you can check the settings or change them.

SET



# Summary of User Data Settings

Here is a summary of the user data menus.

## **1.USER SETTINGS**

Use these settings to set up the operating environment of the fax unit. These settings include important features like registering the names, telephone number and the date and time that prints on documents you send, setting alarms and scanning density, and so on. Do these settings as soon as you set up your fax. After they are set, you should not need to change them very often. (→16-4)

## **2.REPORT SETTINGS**

Use these settings to set the fax to print a report every time you send or receive a document and set up printing a summary report for all your sending and receiving transactions. Use these features to keep track of your fax transactions. (→16-7)

## **3.TX (Send) SETTINGS**

Use these settings to customize how the fax sends documents. With these settings you can turn ECM on and off, set mid-pause time, set up re-dialling and other features. (→16-9)

## **4.RX (Receive) SETTINGS**

Use these settings to customize how the fax receives documents. These settings are important because they determine how the fax operates when it receives a document. (→16-12)

## **5.PRINTER SETTINGS**

Use these settings to set how the fax unit prints documents you receive. These features include selecting a cassette for paper supply, reducing the size of the page, and the order of printing. (→16-14)

## **6.FILE SETTINGS**

Use these settings to set up major features like confidential mailboxes and polling. (→16-17)

## **7.SYSTEM SETTINGS**

Use these settings to set up security and tracking features with passwords and department passwords and codes. You can also set important defaults such as the format in which the date and time will be displayed, selecting the display language, and the sending and receiving start speeds. (→16-24)

# User Settings



DATA REGISTRATION

SET

SET

^

v

1. Open both One-touch Speed Dialling panels. Then press DATA REGISTRATION.

REGISTRATION  
1.DATA REGISTRATION

2. Press SET.

DATA REGISTRATION  
1.USER SETTINGS

3. Press SET.

USER SETTINGS  
1.DATE & TIME

4. Use the search buttons to display the item you want to set or change.

\* Default settings are in bold.

1. <b>DATE &amp; TIME</b>	Register the current date and time using the 24-hour system. (→3-13)
2. <b>UNIT TELEPHONE #</b>	Register your fax number. (→3-13)
3. <b>UNIT NAME</b>	Register your name or company name. (→3-13)
4. <b>SENDER'S NAME</b>	Register up to 99 alternate sender names. Before you send a document, press the TTI SELECTOR button and select a name to replace the name you registered for 3.UNIT NAME. (→3-17)



5.TX TERMINAL ID	Print your ID (transmitting terminal ID) on each page you transmit. (→3-11)
<b>ON</b>	After you turn the terminal ID ON, you can do the following settings. 1.TTI POSITION <b>OUTSIDE IMAGE</b> Terminal ID prints outside the image border <b>INSIDE IMAGE</b> Terminal ID prints inside the image border. 2.TELEPHONE # MARK You can prefix your number with the abbreviations FAX or TEL in your sender ID. <b>FAX</b> Prefixes the number with the abbreviation FAX. <b>TEL</b> Prefixes the number with the abbreviation TEL.
<b>OFF</b>	No terminal ID is not printed on the pages you send.
6.DENSITY CONTROL	Adjust the scanning density from 1-5 for DK (2 is default), 2-6 for STD (4 is default), 3-7 for LT (6 is default).
7. SCAN RESOLUTION	Set the default value for the SUPER FINE setting of the RESOLUTION button on the operation panel. (→6-4) <b>SUPER FINE</b> Scans at 8 dots/mm, 15.4 lines/mm. <b>ULTRA FINE</b> Scans at 16 dots/mm, 15.4 lines/mm.
8.PROGRAM KEY	Use the program button to streamline the procedures for printing activity reports or doing the scanner settings. (→12-4) <b>PRINT REPORT</b> Press the PROGRAM button whenever you need a transmission report for a document you are sending. <b>REPORT</b> If you select this setting, you do not have to open both One-touch Speed Dialling panels to start printing a report. Whenever you need to print a report, press the PROGRAM button. <b>SCANNING MODE</b> Set the scanner buttons (Resolution, Contrast, Document Type) for special settings, like sending a photograph for example. Then you can adjust all the settings just by pressing the PROGRAM button. <b>STAMP</b> If you have installed the optional stamp feature, this option is available. If you select STAMP you can turn the stamp feature on or off without opening both One-touch Speed Dialling panels to press the STAMP button.



# Report Settings

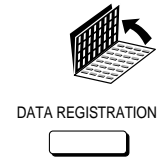

1. Open both One-touch Speed Dialling panels. Then press DATA REGISTRATION.

REGISTRATION  
1.DATA REGISTRATION



2. Press SET.

DATA REGISTRATION  
1.USER SETTINGS



3. Press the search buttons to display REPORT SETTINGS.

DATA REGISTRATION  
2.REPORT SETTINGS



4. Press SET.

REPORT SETTINGS  
1.TX REPORT



5. Use the search buttons to display the item you want to set or change.

\* Default settings are in bold.

1.TX REPORT	Print a transmission report. (→14-10)
<b>PRINT ERROR ONLY</b>	Print a report only if an error occurs.
OUTPUT YES	A report prints for every transmission.
REPORT WITH TX IMAGE	Only available for <b>PRINT ERROR ONLY</b> or <b>OUTPUT YES</b> .
<b>ON</b>	A prompt asks you to confirm whether to print the first page of the document to remind you of what it contains.
OFF	No prompt appears and no first page is printed.
OUTPUT NO	Print no report, even if an error occurs.
2.RX REPORT	Print a reception activity report. (→14-13)
<b>OUTPUT NO</b>	No report prints for document receptions.
PRINT ERROR ONLY	A report prints for reception errors only.
OUTPUT YES	A report prints for every reception.

3.CONFID. RX REPORT	Print a reception activity report every time you receive a document in a confidential mailbox. (→14-15)
<b>OUTPUT YES</b>	A report prints every time a document is received in a confidential mailbox.
OUTPUT NO	No report is printed when a document is received in a confidential mailbox.
4.MEMORY BOX REPORT	Print a reception activity report every time you receive a document in a memory box. (→14-16)
<b>OUTPUT YES</b>	A report is printed every time a document is received in a memory box.
OUTPUT NO	No report is printed when a document is received in a memory box.
5.ACTIVITY REPORT	Print an activity management report. (→14-8)
1.AUTO PRINT	Print an activity report after every 40 transactions.
<b>ON</b>	An activity report prints after the 40th transaction is completed.
<b>OFF</b>	No activity report prints after the 40th transaction is completed.
2.DAILY REPORT TIME	<b>OFF</b> A time is not set to print a transaction report every day.
	<b>ON</b> Allows you to set a time for an activity to be printed every day. Set the report time for the daily report. Use 24-time settings.
3.TX/RX SEPARATE	Print activity report with receptions and transmissions listed separately.
	<b>OFF</b> Transmissions and receptions are listed together in chronological order.
	<b>ON</b> Transmissions and receptions are arranged in chronological order in separate lists.
6.PRT REPORT WHERE	Select a paper supply source for the activity report.
<b>OFF</b>	Report prints from the first available paper supply source.
<b>ON</b>	The number and type of cassettes available depends on the paper cassettes currently installed. The additional front paper cassette is optional.
	<b>SIDE CASSETTE</b> FRONT CASSETT
	<b>With option cassette</b> <b>SIDE CASSETTE</b> FRONT UPPER CAS. FRONT LOWER CAS.

# TX (Send) Settings

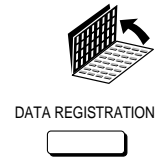

1. Open both One-touch Speed Dialling panels. Then press DATA REGISTRATION.

REGISTRATION  
1.DATA REGISTRATION



2. Press SET.

DATA REGISTRATION  
1.USER SETTINGS



3. Press the search buttons to display TX SETTINGS.

DATA REGISTRATION  
3.TX SETTINGS



4. Press SET.

TX SETTINGS  
1.ECM TX



5. Use the search buttons to display the item you want to set or change.

\* Default settings are in bold.

1.ECM TX	Turn ECM (error correction mode) transmission off and on. This switch does not affect the button setups for One-touch or Coded Speed dialling. (→4-6, 4-14)
<b>ON</b>	All transmissions are conducted with ECM if the other party's fax supports ECM.
OFF	ECM is turned off.
2.MID PAUSE SET	Set the length of the pause entered between number when you press the PAUSE button (01 to 15 sec.) (→4-3)
	<b>02SEC</b>

3.AUTO REDIAL	Select whether to perform automatic redial when the other line is busy or no answer. (→6-16)
<b>ON</b>	<p>Customize the redial operation.</p> <p>1.REDIAL TIMES                      From 01 to 10 times. (<b>02TIMES</b>)</p> <p>2.REDIAL INTERVAL                From 02 to 99 minutes. (<b>02MIN.</b>)</p> <p>3.TX ERROR RESEND                Set redialling to handle error transmissions.</p> <p><b>ON</b>                                      Turn page resend off and on, and select what pages to resend.</p> <p>RESEND TX FROM <b>ERROR &amp; 1ST PG</b> ERROR PAGE ALL PAGES</p> <p><b>OFF</b>                                      No portion of a document is re-sent after an error occurs.</p>
<b>OFF</b>	After the first attempt at dialling fails, re-dialling is not attempted.
4.BATCH TX	If there is more than one document waiting in the memory to be sent to the same destination, after the timer goes off to send the first document, then all documents are sent together in the same transmission. With this feature the fax unit makes one phone call instead of faxing each document with a separate phone call. This feature saves time and money. (→16-27)
<b>ON</b>	
<b>OFF</b>	
5.QUICK ON-LINE TX	Turn quick memory sending off and on. When ON the fax unit starts sending the document while it is still being scanned. (→6-11)
<b>ON</b>	
<b>OFF</b>	
6.ERASE FAILED TX	Determine what happens to the document in the memory if an error occurs during its transmission.
<b>OFF</b>	Document remains in the memory after an error occurs during sending.
<b>ON</b>	Document is erased from the memory if an error occurs during transmission.

---

7.TIME OUT	Set the interval between dialling (entering phone numbers) when sending to more than one destination. (→6-20)	
<b>ON</b>	Fax scans the document in 5 or 10 seconds after you enter the phone #.	
<b>OFF</b>	Press START/SCAN to begin transmission. Otherwise, the fax unit returns to standby.	

---

8.TX STAMP	Turn stamping off or on and how documents are to be stamped. (→12-7)	
<b>ON</b>	<b>STAMP ACTION</b>	
	<b>DIRECT &amp; MEMORY TX</b>	Stamps only documents sent direct and from memory.
	DIRECT TX	Stamps documents sent with direct sending only.
<b>OFF</b>	The stamp feature is turned off and disabled.	

**Note:**

*The stamp feature is available as an option. If the stamp option is not provided on your fax machine, this item will not appear in the menu.*

---

# RX (Receive) Settings

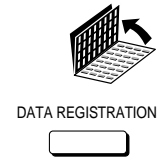

1. Open both One-touch Speed Dialling panels. Then press DATA REGISTRATION.

REGISTRATION  
1.DATA REGISTRATION



2. Press SET.

DATA REGISTRATION  
1.USER SETTINGS



3. Press the search buttons to display RX SETTINGS.

DATA REGISTRATION  
4.RX SETTINGS



4. Press SET.

RX SETTINGS  
1.ECM RX



5. Use the search buttons to display the item you want to set or change.

\* Default settings are in bold.

1.ECM RX	Turn the ECM (error correction mode) receiving off and on. This switch does not affect the button setups for One-touch or Coded Speed Dialling. (→4-6, 4-14)
<b>ON</b>	All receptions are conducted with ECM if the other party's fax supports ECM.
OFF	ECM is turned off.
2.MAN/AUTO SWITCH	Set the fax machine to switch to document receive mode after ringing for a specified length of time in the manual receive mode.



<b>OFF</b>	The fax will keep ringing until someone answers the call manually with the optional handset or a connected extension telephone.	
<b>ON</b>	<b>F/T RING TIME</b>	Set the length of time to elapse before the fax machine switches to document receiving. Default: <b>15 sec.</b> (01-99 sec.)
<b>3.REMOTE RX</b>	Receive from a remote telephone with pre-set setting. (→7-7)	
<b>ID CALL #</b>	You can dial a number code on the remote extension to start receiving a document. Default is <b>25</b> . Setting range: 00 to 99.	
<b>HOOK</b>	You can start receiving the document after you hang up the handset of the extension telephone after you hear the slow beep of an incoming document transmission. (You can receive documents using this method only if the other party's fax can send a CNG signal.)	
<b>OFF</b>	Remote receiving is turned off and disabled.	
<b>4.MEMORY RX</b>	Select how incoming documents are to be received in the memory if the fax runs out of toner or paper. (→8-2)	
<b>ON</b>	Remainder of the fax is stored in the memory and can be printed out as soon as you re-fill the paper cassette, change the toner cartridge or clear the paper jam.	
	<b>MEMORY RX ALARM</b>	The memory alarm alerts you when a document has been received in the memory.
	<b>OFF</b>	No alarm sounds when the fax runs out of toner or recording paper during document reception.
	<b>ON</b>	An audible alarm sounds when the fax runs out of toner or recording paper and the remainder of the document is stored temporarily in the memory.
<b>OFF</b>	Memory receiving is turned off. If the fax runs out of toner or recording paper during a document reception, the remainder of the document is not saved in the memory. The other party must re-send the document.	
<b>5.RX PAGE FOOTER</b>	Print a footer in the lower right corner of every received page. The footer contains the date, day, time received, transaction number, and page number. (→3-12)	
<b>OFF</b>	No RX FOOTER prints at the bottom of the page.	
<b>ON</b>	Turns on printing of an RX FOOTER at the bottom of every page you receive.	

# Printer Settings



DATA REGISTRATION



1. Open both One-touch Speed Dialling panels. Then press DATA REGISTRATION.

REGISTRATION  
1.DATA REGISTRATION

2. Press SET.

DATA REGISTRATION  
1.USER SETTINGS

3. Press the search buttons to display PRINTER SETTINGS.

DATA REGISTRATION  
5.PRINTER SETTINGS

4. Press SET.

PRINTER SETTINGS  
1.# OF RX COPIES

5. Use the search buttons to display the item you want to set or change.

\* Default settings are in bold.

1.# OF RX COPIES	Select the number of copies (from 01 to 99) of received documents you want printed. Default is 01 copy.	
2.SELECT CASSETTE	Select how you want over-size documents to be divided when the paper in the paper cassette is too small.	
1.CASSETTE SW A	Selects how legal-size documents are divided. This switch is effective only when the side cassette is set to legal-size and out of legal-size paper.	
	<b>ON</b>	Divide legal-size documents into two pages.
	OFF	Receive legal-size documents in memory.
2.CASSETTE SW B	Selects how letter-size documents are received on larger paper. This switch is effective only when the letter-size paper runs out.	
	<b>ON</b>	Prints the letter-size document on the larger paper (with white space).
	OFF	Prints the letter-size document in the memory.
3.RX REDUCTION	Receive images at a reduced size.	
OFF	Turns off image reduction.	
<b>ON</b>	Turns on image reduction.	
	1.RX REDUCTION	
	<b>AUTO SELECTION</b>	The fax unit automatically reduces the image to the size of the selected paper.
	FIXED REDUCTION	You set the reduction rate. (75%, <b>90%</b> , 95%, 97%)
	2.SELECT REDUCE DIR	Select the direction of reduction for the percentage of fixed reduction selected above.
	<b>HORIZ &amp; VERTICAL</b>	Reduction performed in the horizontal and vertical direction.
	VERTICAL ONLY	Reduction performed in the vertical direction only.

---

4.PRINT IN ORDER	Set the order of printing.
<b>OFF</b>	Arrange received document pages in reverse order.
ON	Arrange received document pages in the order they were sent. Printing does not start until all pages are received.

---

5.SELECT DENSITY	Adjust the print density of documents you receive. LT (Light), <b>STD</b> (Standard), DK (Dark)
------------------	---

---

6.TONER SUPPLY LOW	Set the fax to continue printing even after toner runs low and the CHANGE CARTRIDGE indicator lights and the REPLACE CARTRIDGE message appears.
<b>RX TO MEMORY</b>	Stop printing and receive the remainder of the document in the memory.
KEEP PRINTING	Ignore the warning and keep printing until the document is completely printed.

---

# File Settings

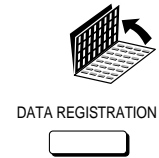

1. Open both One-touch Speed Dialling panels. Then press DATA REGISTRATION.

REGISTRATION  
1.DATA REGISTRATION



2. Press SET.

DATA REGISTRATION  
1.USER SETTINGS



3. Press the search buttons until you see FILE SETTINGS.

DATA REGISTRATION  
6.FILE SETTINGS



4. Press SET.

FILE SETTINGS  
1.CONFID. MAILBOX



5. Use the search buttons to display the item you want to set or change.

\* Default settings are in bold.

1.CONFID. MAILBOX	Set up confidential mailbox. (→10-2)
1.SETUP FILE	Set up a confidential mailbox.
SET BOX #	Create a two-digit confidential mail box number.
1.FILE NAME	Give the mailbox a name up to 24 characters long.
2.PASSWORD	Assign a password to protect the mailbox from being changed or deleted.
3.SUBADDRESS	Enter a 20-digit (max.) ITU-T subaddress for reception.
4.RX PASSWORD	Enter a 20-digit (max.) ITU-T password for reception.
5.# OF RX COPIES	Sets the number of copies printed from every document.
2.CHANGE DATA	Change all the mailbox settings done with the settings above.
SET BOX #	Enter the number of the mailbox you want to change.
PASSWORD	Enter the password protecting the mailbox settings. You can now change any of the settings listed in the table above (1. SETUP FILE).

---

3.DELETE FILE	Delete a mailbox.
SET BOX #	Enter the number of the mailbox you want to delete.
PASSWORD	Enter the password protecting the mailbox you want to delete.

---

2.RELAY TX GROUP	Set up relay box so your fax machine can relay document transmissions to other fax machines in your area. (→9-3)
1.SETUP FILE	Set up the relay box.
SET RLY TX GROUP#	Set a two-digit relay group number (00-99).
1.GROUP DIAL NAME	Give the relay group a name (length: 24 characters).
2.PASSWORD	Assign a four-digit password to protect the relay box settings.
3.SUBADDRESS	Enter a 20-digit (max.) ITU-T subaddress.
4.RX PASSWORD	Enter a 20-digit (max.) ITU-T password.
5.SELECT ORIG UNIT	Set your fax to check the incoming relay command to make sure the originator is registered.
<b>ON</b>	Receives and obeys incoming relay commands for registered originators only.
TEL=	Use the One-touch or Coded Speed Dialling buttons to register originators.
<b>OFF</b>	Receives and obeys all incoming relay commands.
6.PRINT RX DOC.	Turns printing on/off for documents received for relay.
<b>ON</b>	Prints a copy of every document relayed.
<b>OFF</b>	No copy is printed.
7.SELECT LOCATION	Use the One-touch or Coded Speed Dialling buttons to select the fax numbers to receive the document relayed from your fax machine.
TEL=	Send a TX report from your fax machine (the relay unit) to the originator of the transmission.
8.TX REPORT	Transmits a document relay report to the originator.
<b>TRANSMIT</b>	No report is transmitted.
<b>NOT TRANSMIT</b>	Set the fax machine to hold the document from the originator and then relay it at a specified time. Use 24-hour setting. Up to 5 time settings are possible.
9.TX START TIME	
10.RELAY B'CAST	Turn relay broadcasting off temporarily without cancelling or changing all of the relay box settings.
<b>OFF</b>	In order for relay broadcasting to occur, this setting must be on.
<b>ON</b>	
2.CHANGE DATA	Change or add the settings on the relay box.
SET RLY GROUP TX#	Enter the number of the relay box you want to change.
PASSWORD	Enter the password protecting the relay box settings.
	You can now change any of the settings listed in the table above (1. SETUP FILE).
3.DELETE FILE	Delete a relay box and all settings.
SET RLY TX GROUP#	Enter the number of the relay box you want to delete.
PASSWORD	Enter the password of the relay box you want to delete.

---

---

### 3.MEMORY BOX

Set up a general memory box to handle ITU-T subaddress and password transactions. (→8-13)

#### 1.SETUP FILE

Create a general memory box and do all the general memory box settings.

#### SET BOX #

Give the general memory box a box number.

- 1.FILE NAME
- 2.PASSWORD

Give the memory box a name up to 24 characters long.  
Assign a four-digit password to protect the memory box settings.

#### 3.SUBADDRESS

Enter a 20-digit (max.) ITU-T standard subaddress. *You must enter a subaddress in order to use the memory box features.*

#### 4.TX PASSWORD

Enter a 20-digit (max.) ITU-T password.

#### 5.RX PASSWORD

Enter a 20-digit (max.) ITU-T password.

#### 6.RECEIVE

**NO**

Turn memory box receiving off.

**YES**

Turn memory box receiving on.

#### 1.SELECT ORIG UNIT

Turn on checking to make sure the originator is registered on your fax.

**OFF**

Receive all documents, regardless of origin.

**ON**

Receive documents from registered sources only.

TEL=

Use the One-touch or Coded Speed Dialling buttons to register fax numbers from which you want the memory box to receive documents.

#### 2.PRINT RX DOC.

Turn on printing of documents received in the memory box.

**OFF**

Documents received in the memory box are not printed.

**ON**

Documents received in the memory box are printed.

#### 1.PRINT METHOD

Set the print method.

**AUTO**

Print documents automatically as they are received.

MAN.

Print documents manually.

#### 2.# OF RX COPIES

Set the number of document copies to print.

#### 7.TRANSMIT

Transmit documents from the memory box.

**NO**

A document can not be transmitted from the memory box.

**YES**

A document can be transmitted from the memory box.

#### 1.SELECT LOCATIONS

Select fax telephone numbers to which to send documents from the memory box. Use One-touch or Coded Speed Dialling buttons to register the destinations.

TEL=

#### 2.TX DOCUMENT

Transmit documents *received* in the memory box or *scanned* into the memory box.

#### 1.RECEIVED DOCUMENT

Transmit or do not transmit documents received in the memory box.

**TRANSMIT**

Documents received in the memory box are to be transmitted.

TX REPORT

Send a TX report to the originator for every document

**TRANSMIT**

A transmission report is sent.

NOT TRANSMIT

A transmission report is not sent.

NOT TRANSMIT

Documents received in the memory box are not to be transmitted.

#### 2.SCAN DOCUMENT

Transmit or do not transmit documents scanned into the memory box.

**TRANSMIT**

Scanned documents can be transmitted.

NOT TRANSMIT

Scanned documents can not be transmitted.

#### 3.TX START TIME

Set a time for transmission of documents from the memory box.

**EVERYDAY**

Set the time using the 24-hour system. Up to 5 times can be sent.

SELECT DAYS

Select a day. Up to 5 times can be set for each day.

---

8.POLLING TX	For the memory box, turn polling sending on and off. Memory box can not be used as a polling box. Memory box can be used as a polling box.
<b>NO</b>	
<b>YES</b>	
1.ERASE AFTER TX	Set how the document in the memory box is to be handled after being polled and sent. Document is erased after polling/sending. Document remains in the memory box after polling/sending.
<b>ON</b>	
<b>OFF</b>	
2.TX DOCUMENT	Transmit documents <i>received</i> in the memory box or <i>scanned</i> into the memory box for polling and receiving. Set documents received in the memory box for sending after polling.
1.RECEIVED DOCUMENT	
<b>TRANSMIT</b>	Documents received in the memory box from other faxes can be transmitted.
NOT TRANSMIT	Documents received in the memory box from other faxes can not be transmitted.
2.SCAN DOCUMENT	Set documents scanned into the memory box for sending after polling. Documents scanned into the memory box can be transmitted. Documents scanned into the memory box can not be transmitted.
<b>TRANSMIT</b>	
NOT TRANSMIT	
2.CHANGE DATA	Change settings for the memory box or add settings you did not do when you created the memory box.
SET BOX #	Enter the number of the box you want to change.
PASSWORD	Enter the password protecting the memory box settings. You can now change any of the settings listed in the table above.
3.DELETE FILE	Delete the general memory box.
SET BOX #	Enter the box number of the memory box you want to delete.
PASSWORD	Enter the password protecting the memory box that you want to delete.
4.PRESET POLLING	Set up preset polling/receiving setting. (→11-5)
1.SETUP FILE	Set up a setting to poll at preset time.
SET BOX #	Create a two-digit preset polling box.
1.FILE NAME	Enter the name of the file (24 characters).
2.PASSWORD	Enter a four-digit password to protect the polling settings.
3.SELECT LOCATIONS	Select the numbers of the fax units you want to poll. Use the One-touch or Coded Speed Dialling buttons to enter the numbers of the fax machine that you want to poll.
TEL=	
4.START TIME	Set the time(s) that you want to start polling.
<b>EVERY DAY</b>	Set up to 5 times for every day.
SELECT DAYS	Set up to 5 times for each day selected.



---

2.CHANGE DATA	Change the settings for preset polling/receiving.
SET BOX #	Enter the number of the box you want to change.
PASSWORD	Enter the password protecting the preset polling settings. You can now change any of the settings listed in the table above (1. SETUP FILE).
3.DELETE FILE	Delete the setting to poll at preset time.
SET BOX #	Set the box number for the box you want to delete.
PASSWORD	Enter the password of the file you want to delete.

---

5.POLLING BOX	Set up a polling box to store a document in your fax machine until your fax machine is polled to send the document. (→11-17)
1.SETUP FILE	Set up a polling box to hold a document until it is polled by and sent to another fax machine.
SET BOX #	Set a box number for the polling box.
1.FILE NAME	Enter a file name (24 characters).
2.PASSWORD	Enter a password to protect the polling box settings.
3.SUBADDRESS	Enter a 20-digit (max.) standard ITU-T subaddress.
4.TX PASSWORD	Enter a 20-digit (max.) standard ITU-T password.
5.ERASE AFTER TX	Tell the fax machine how to handle the document after it is polled and sent.
ON	Document is erased from the memory after it is polled and sent.
OFF	Document is not erased and remains in the memory after it is polled and sent.
2.CHANGE DATA	Change the settings on the polling box. You can now change any of the settings listed in the table above (1. SETUP FILE).
SET BOX #	Set a box number you want to change.
PASSWORD	Enter the password of the polling box you want to change. You can now change any of the settings listed in the table above (1. SETUP FILE).
3.DELETE FILE	Delete the polling box file.
SET BOX #	Set the box number for the box you want to delete.
PASSWORD	Enter the password of the polling box file you want to delete.

---

---

6. TRANSFER	Set the fax unit to transfer the documents it receives to other faxes. (→7-11)
1. SETUP FILE	Create a file to receive and transfer documents.
1. FILE NAME	Enter a file name (24 characters).
2. SELECT LOCATIONS TEL=	Select the numbers of the fax machines where you want documents transferred. Use the One-touch or Coded Speed Dialling buttons to enter the numbers of the fax machines where you want documents transferred.
3. PASSWORD	Enter a four-digit password to protect the transfer file settings.
4. SELECT ORIG UNIT	Select the telephone numbers of the fax machines you want have received and transferred.
<b>OFF</b>	All fax transmissions are received and transferred.
<b>ON</b>	The fax machine receives and transfers transmissions only from fax units that you designate by fax telephone number.
TEL=	Use the One-touch or Coded Speed Dialling buttons to designate originator fax machines for receive and transfer.
5. TIME SETUP	Set a time period wherein documents are to be received and transferred.
1. START TIME	Set a specified time to start transfer operation.
<b>EVERY DAY</b>	Set up to 5 times every day.
SELECT DAYS	Select one or several days for document transfer. You can set 5 times for any day(s) you select.
2. END TIME	Set a specified time to end transfer operation.
<b>EVERY DAY</b>	Set up to 5 times every day.
SELECT DAYS	Select one or several days for document transfer. You can set 5 times for any day(s) you select.
6. PRINT RX DOC.	Set the fax machine that transfers the document to print a copy of the transferred document.
<b>OFF</b>	Received and transferred documents are not printed.
<b>ON</b>	A copy of every document received and transferred is printed.
# OF RX COPIES	Set the number of document copies to print.
2. CHANGE DATA	Change the transfer settings.
PASSWORD	Enter the four-digit password protecting the transfer settings. You can now change any of the settings listed in the table above (1. SETUP FILE).
3. DELETE FILE	Delete the transfer settings file.
PASSWORD	Enter the four-digit password of the transfer file you want to delete.

---

# System Settings



DATA REGISTRATION



SET



1. Open both One-touch Speed Dialling panels. Then press DATA REGISTRATION.

REGISTRATION  
1.DATA REGISTRATION

2. Press SET.

DATA REGISTRATION  
1.USER SETTINGS

3. Press the search buttons until you see the display below.

DATA REGISTRATION  
7.SYSTEM SETTINGS



4. Press SET.



SYSTEM SETTINGS  
1.PASSWORD

5. Use the search buttons to display the item you want to set or change.



\* Default settings are in bold.

---

<b>PASSWORD</b>	Enter the system password protecting the System Settings. (You will not have to do this if the System Settings are not yet password protected.) (→13-2)
-----------------	---

---

<b>1.PASSWORD</b>	Enter a four-digit password to protect the System Settings.
-------------------	---

---

<b>2.RESTRICTIVE CODES</b>	Set restrictions for sending and printing with department access codes and user access codes. (→13-5)
----------------------------	---

<b>1.TX SETTINGS</b>	Restrict sending with department and user access codes.
<b>OFF</b>	Turn off restrictions on sending. This turns the feature off without cancelling the department access codes and passwords.
<b>ON</b>	
<b>DAC SETUP</b>	Set a DAC (department access code).
<b>ON</b>	Turn on department access codes.
<b>ENTER DAC</b>	
<b>01:</b>	Press the search buttons to select a number (01 to 99), then enter a four-digit department access code.
<b>DAC PASSWORD</b>	Enter a four-digit password for the department access password.
<b>OFF</b>	Turn off restrictions by department access codes and passwords but turn on restrictions by user access code.
<b>USER ACCESS CODE</b>	A four-digit number you set to restrict sending.

---

<b>2.PRINTER SETTINGS</b>	Restricts document printing and copying with a four-digit access code.
<b>OFF</b>	
<b>ON</b>	
<b>USER ACCESS CODE</b>	A four-digit number you set to restrict printing and copying.

---

<b>3.TEL SETTING</b>	Allows you to restrict use of the telephone for voice communication.
<b>OFF</b>	
<b>ON</b>	

---

3.MEMORY LOCK RX	Turn forced memory receiving on and off. (→13-15)
<b>OFF</b>	1.MEM. LOCK PASSWORD Enter a four-digit password.
ON	2.REPORT Set reports to print (or not print) when the forced memory receiving feature is on.
	<b>OUTPUT NO</b> Reports are not printed when the forced memory receiving feature is on.
	OUTPUT YES Reports are printed when the forced memory receiving feature is on.
	3.TIME SETUP Set a time to turn on forced memory receiving.
	<b>OFF</b>
	ON
	1.START TIME Turn on memory receiving at a specified time.
	<b>EVERY DAY</b> Set up to 5 times for every day.
	SELECT DAYS Set up to 5 times for each selected day of the week.
	2.END TIME Turn off memory receiving at specified time.
	<b>EVERY DAY</b> Set up to 5 times for every day.
	SELECT DAYS Set up to 5 times for each selected day of the week.
4.RX RESTRICTION	Turn off junk mail. (→13-14)
<b>OFF</b>	Anyone can dial your fax and send a document.
ON	Another party can dial your fax and send a document only if their number is registered on your fax for a One-touch or Coded Speed Dialling button.
5.DATE SETUP	Set the format for the date display in the LCD or your fax machine.
MM/DD/YY	
<b>DD/MM 'YY</b>	
'YY MM/DD	

6.DISPLAY LANGUAGE	<p>Select a language for prompts, messages, menus and printed reports. The number of languages available may be different depending on where you purchased your fax machine.</p> <p style="text-align: center;"><b>ENGLISH, FRENCH, SPANISH, GERMAN, DUTCH, ITALIAN, SLOVENE, SWEDISH, FINNISH, PORTUGUISE, DANISH, NORWEGIAN</b></p>
7.TX START SPEED	<p>Set the transmission speed for all documents you send. Available settings: <b>14400</b>, 9600, 7200, 4800, 2400 bps</p>
8.RX START SPEED	<p>Set the transmission speed for all documents you receive. Available settings: <b>14400</b>, 9600, 7200, 4800, 2400 bps</p>
9.RX PASSWORD	<p>Set an RX password to match the ITU-T password of all incoming document transmissions.</p> <p>Enter a 20-digit (max.) ITU-T password. To receive a document, this RX password must match the ITU-T password of the incoming document.</p> <p>After the RX password has been set, all incoming documents must have a matching ITU-T password.</p> <p style="text-align: center;">-or-</p> <p>The document will be received regardless of this setting if the incoming document has a matching subaddress and password for a memory box.</p>
10.ENERGY SAVER	<p>Set the fax machine to reduce power consumption when not in use. (→3-19)</p>
OFF	<p>Fax machine does not power down even when it is idle.</p>
ON	<p>The fax machine reduces power consumption after it has remained idle for a specified length of time.</p>
	<p style="text-align: center;"><b>ENERGY SVR TIME</b>      Set the idle time to elapse and trigger reduced power consumption. (03 to 30 min.) Default is <b>03</b> min.</p>
11.PHONE NO. CHECK	<p>Allows you to prevent sending a document to an unwanted destination. The number you dial is checked with connected number and if they match, then the document is sent.</p>
OFF	<p>The number is not checked.</p>
ON	<p>The fax uses the last six digits of the number you dial to match with the last six digits of the other party's number registered on the remote fax. If the numbers match the document is sent. Otherwise, the document is not sent.</p>

# ***Relationship between BATCH TX, QUICK ON-LINE TX, and Timer Settings***

BATCH TX	QUICK ON-LINE TX	TIMER SET WITH SPEED DIALLING BUTTONS	
		YES	NO
ON	ON	Documents go into memory and are grouped. Group is sent at the specified time.	If the line is available, documents are not grouped and are sent immediately. If the line is busy, documents go into memory, are grouped, then are sent when the line becomes available.
ON	OFF	Documents go into memory and are grouped. The group is sent at the specified time.	Documents go into memory, are grouped and then are sent when the line becomes available.
OFF	ON	Documents go into memory, but are not grouped. Each document is sent at the specified time.	If the line is available, documents are not grouped and are sent immediately. If the line is busy, documents go into memory, are not grouped, and are sent when the line becomes available.
OFF	OFF	Documents go into memory, but are not grouped. Each document is sent at the specified time.	Documents go into memory, are not grouped and are sent when the line becomes available.





# Appendix A

## Specifications

---

### General

<b>Sheet size:</b>	Max. width 279 mm Min. width 148 mm
<b>Automatic Document Feeder (ADF) Capacity:</b>	50 A4 or letter size pages
<b>Effective scanning image size:</b>	Width (A4) 208 mm
<b>Recording paper size:</b>	Width (letter, legal) 216 mm (A4) 210 mm
<b>Paper Cassette Capacity:</b>	Side paper cassette: approximately 100 sheets (letter, legal, A4) Upper front paper cassette approximately 500 sheets (A4) Lower front paper cassette approximately 500 sheets (A4) (optional)
<b>Compatibility:</b>	G3
<b>Modem speed:</b>	14.4/12/9.6/7.2/4.8/2.4 Kbps
<b>Memory:</b>	1.25 MB (80 pages* approx.) Upgrade Option plus 2 MB (additional 128 pages* approx.) = total 208 pages* approx. plus 4 MB(additional 256 pages* approx.) = total 336 pages* approx. plus 6 MB(additional 384 pages* approx.) = total 464 pages* approx. plus 8 MB(additional 512 pages* approx.) = total 592 pages* approx.

<b>LCD (Liquid Crystal Display):</b>	20 x 2
<b>Data compression system:</b>	MH, MR, MMR, JBIG**
<b>Transmission time:</b>	G3 Mode ECM-JBIG Approx. 5 sec./pg.* ECM-MMR Approx. 6 sec./pg.* MR Standard mode Approx. 12 sec./pg.* MH Standard mode Approx. 15 sec./pg.*
<b>Scanning line density:</b>	G3 Mode Standard: 8 dots/mm x 3.85 lines/mm Fine: 8 dots/mm x 7.7 lines/mm Super Fine: 8 dots/mm x 15.4 lines/mm Ultra Fine: 16 dots/mm x 15.4 lines/mm (interpolated)
<b>Toner cartridge:</b>	Canon FX4 Toner Cartridge

## Operation

<b>Fax printing speed:</b>	Approx. 8 pp./min.
<b>Scanning method:</b>	Solid state electronic scanning by contact image sensor
<b>Recording (printing) method:</b>	Laser beam electronic circuit
<b>Print resolution:</b>	600 dpi x 600 dpi
<b>Applicable lines:</b>	Subscribers telephone circuit (PSTN)

# Dial Features

- One-touch Speed Dialling (Registration for 72 numbers)
- Coded Speed Dialling (Registration for 128 numbers)
- Group Dialling
- On-hook dialling
- Manual dialling with 10-button keypad
- Automatic re-dialling
- Manual re-dialling
- Program dialling
- Dial search

# Networking Features

## Transmitting:

- Sequential broadcast
- Batch transmission
- Confidential transmission
- Relay broadcasting
- Password/subaddress sending
- Polling transmission
- Error re-transmission
- Delayed transmission

## Receiving:

- Memory lock reception
- Polling reception
- Timer polling
- Confidential mailbox
- Relay broadcasting
- Transfer
- Received image reduction
- Collating

# Copier Features

## Scanning resolution:

- 400 dpi x 600 dpi  
(Direct Copy/Interpolated),
- 16 dots/mm x 15.4 lines/mm  
(Memory Copy/Interpolated)

<b>Printing resolution:</b>	600 x 600 dpi
<b>Copy speed:</b>	First copy time Approx. 25 sec.* (from front upper paper cassette) Multi copy speed Approx. 8 cpm*
<b>Multiple copy:</b>	Up to 99 pages

## ***Telephone Features***

Optional telephone handset  
 Extension phone hookup  
 Remote reception by extension phone  
 TONE button  
 PAUSE button  
 R button  
 D.T. button

## ***Power***

<b>Power source:</b>	200 – 240 V/50 – 60 Hz
<b>Battery backup:</b>	12 hours
<b>Power consumption:</b>	
<b>Standby</b>	approx. 11 W at 25°C
<b>Operation</b>	approx. 380 W (100% of document black copy)
<b>Energy standby</b>	approx. 2 W

## ***Operating Environment***

<b>Temperature:</b>	10°C to 32.5°C
<b>Humidity:</b>	20 – 80% RH

## ***Weight***

Approx. 20 kg  
 Approx. 26.5 kg (with optional cassette)

# ***Dimensions***

406 mm w x 460 mm d x 388 mm h  
(both with and without handset)

406 mm w x 460 mm d x 475 mm h  
(both with and without handset and with  
optional cassette)

- \* Based on Canon FAX Standard Chart No.1 (Standard Mode).
- \*\* JBIG is a new ITU-T standard image data compression method. JBIG's compression method allows data to be compressed more efficiently than MMR, a conventional compression method. JBIG is especially effective when transmitting halftone image documents. Because the smaller data size requires less transmission time, JBIG saves you time and money.

Specifications are subject to change without notice.



# Appendix B

## Documents You Can Scan

---

Follow these guidelines if you need exact information about the dimensions of documents you can scan.

### ***Document Media to Avoid***

Avoid trying to scan wrinkled or creased paper, carbon or carbon back paper, curled paper, coated paper, torn paper, onion skin or other very thin paper.

### ***Specifications for Paper Documents You Can Scan***

---

Quality	Use plain bond, typewriter quality without curl, folds, or rough edges.
Weight	60 g/m <sup>2</sup> to 82.5 g/m <sup>2</sup>
Thickness	0.08 to 0.13 mm
Storage	18°C to 24°C 50% to 60% RH

---

### ***Document Thickness***

The thickness of documents that you feed into the fax should be within the range 0.06-0.13 mm. If you have to feed a thick document, first make a copy of the document on a copy machine and then send the copy.

## Document Size

Make sure the documents you feed into the fax are within the dimensions shown below. For documents that are larger or smaller than these recommended limits, reduce them or enlarge them on a copy machine and then send the copy.

### Maximum Document Size

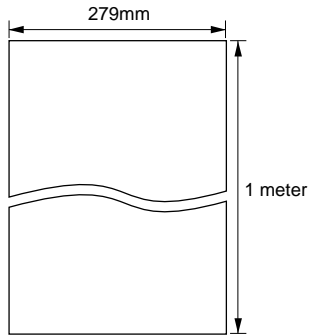

### Minimum Document Size

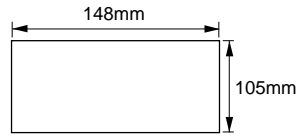

## Scanning Area on the Document

The shaded areas in the illustration below show the parts of the document page that are not scanned by the fax. Before you send a document, make sure the document margins are wider than the margins shown below

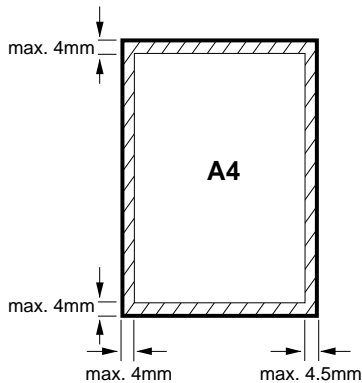



# Printing Area

Note that the fax unit can not print completely from the edge of one border to another. The size of the margin differs slightly with the paper size.

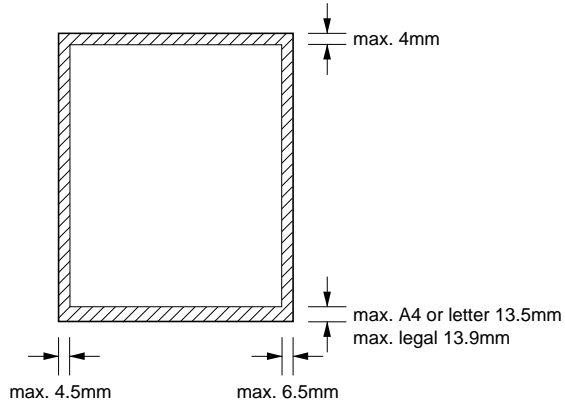



## A

### **Activity report**

Journal of transactions, both sent and received.

### **ADF**

Stands for *automatic document feeder*. The ADF can hold 50 sheets of A4-size paper. You load a document once, and the fax then feeds each sheet of the document one by one.

### **Automatic dialling**

Dialling fax or telephone numbers by pressing one or four buttons. To use automatic dialling, you must register the numbers in the fax unit's memory. See also *One-touch Speed Dialling, Coded Speed Dialling, and Group Dialling*.

### **Automatic redialling**

When the other fax is busy or does not answer, or when an error occurs when sending, the fax waits 2 minutes and then automatically re-dials the same number. If there is still no answer, it makes 1 more attempt after waiting for 2 minutes. After the last unsuccessful attempt, the fax prints an activity report.

### **Automatic reduction of received image**

At the top of the received document, the date, time, company name, and fax number can be printed. Because this extra information at the top of the received document requires additional space, the number of pages of the received document may increase. Automatic reduction of the received image avoids this by reducing the size of the printed image.

## B

### **Batch sending**

When several documents are scanned into the memory to be sent to the same destination at a specified time, the documents are sent together in the same transmission one after the other.

### **bps**

Stands for *bits per second*.

### **Broadcasting**

Transmitting a document to more than one location.

## C

### **CCITT/ITU-T**

Formally known as CCITT, Consultative Committee for International Telegraph and Telephone. CCITT has been replaced by the International Telecommunications Unit-Telecommunications Sector (ITU-T), a committee created to set international standards for telecommunications.

### **Coded Speed Dialling**

Allows you to automatically dial a facsimile number by pressing only four buttons, CODED DIAL and a three-digit code. You can register up to 128 facsimile numbers for Coded Speed Dialling. When you register the facsimile number, you can also enter the receiving party's name, set the speed for the transmission, and other useful features.

### **Confidential mailbox**

Two-digit numbers between 00 and 99. If the number is a single digit, precede it with a zero. The fax can have up to 70 confidential mailboxes for individual users.

### **Confidential mailbox password**

Confidential mailbox passwords are four-digit decimal numbers between 0000 to 9999. To print a confidential document received in the memory, you must enter your confidential mailbox password. Remember your password. You will need it to print confidential documents received in the memory. Later if you want to change your password, you must first enter the current password before you are allowed to complete the procedure.

### **Confidential receiving**

To receive a confidential document you must first create a mailbox and register your confidential mailbox password. You use the password to print out confidential documents that you receive in the memory. Confidential mailbox passwords are four-digit decimal numbers between 0000 to 9999. When you receive a confidential document in your mailbox, the fax prints a Confidential RX Report.

### **Confidential sending**

To use confidential sending, there are two ways. One is to first register the procedure with a One-touch Speed Dialling button. After you register the procedure, all you have to do is feed the document into the fax and press the button. The other is to press CONFIDENTIAL MAILBOX button and dial.

## D

### **Default**

The fax is programmed in the factory with settings that we recommend. These are known as *factory default* settings. You can customize your fax by programming settings other than the factory default settings. For details, see Chapter 16 of this User's Guide.

**Delayed transmission**

With delayed transmission (also called timer sending), you can set a time for the document to be sent. You do not have to be in the office when the document is sent at the specified time. With delayed transmission you can send the same document to more than one destination at a preset time. If you frequently send the same document to several destinations, you can save time by using Group Dialling.

**Density control**

You can darken or lighten documents that you send or receive with buttons at the top of the operation panel.

**Destination label**

Attachable label used to label speed dialling buttons on the facsimile machine. Write the name of the other party on the label and then paste the label above the button where his or her fax number is registered.

**Dialling methods**

Dialling numbers at the press of one or a few buttons. To use automatic dialling, you must register the fax numbers in the memory of the machine.

- Regular dialling
- One-touch Speed Dialling
- Coded Speed Dialling
- Group Dialling
- Directory Dialling

**Direct sending**

Use direct sending if the memory is full but you still want to send a document. Direct sending scans and sends one page at a time. The document is not scanned into the memory, so it takes a little more time to get your original document back.

**Document**

The single sheet or stack of papers containing the data you want to send through or receive from a fax machine.

**Document density**

The document density settings alter the lightness or darkness of the documents sent or received. See *density control*.

**Document guides**

Guide the document into the fax for scanning, copying, or sending.

**Document memory list**

The memory list shows what documents are currently stored in the fax memory. Each memory list shows:

- Transaction number for each document
- How each document was stored
- Name and number the fax was sent to if they are registered for One-touch or Coded Speed Dialling.
- Number of pages in the document.
- Date and time each document was stored in the memory and when it will be sent.
- Sender's name (TTI)
- Errors (if any) that occurred when sending the document.

**Document tray**

Holds documents ejected from the fax unit after they have been scanned into memory, copied, or sent by direct sending.

**Dual access**

Enables you to scan a transmission, even if the fax is copying, sending or receiving a document. You do not have to wait until the fax finishes the current send/receive transmission. While the facsimile sends a document from the memory, you can load other documents into the memory, copy documents, print out reports, or register information.

## E

**ECM**

Stands for *error correction mode*. Reduces system and line errors when sending or receiving from another fax with ECM capability. When there is noise on the telephone line, a distortion or blank area can occur in the document received by the other party. ECM divides one page into a number of blocks and checks for lost data block by block. When some data is lost in a certain block, ECM repeats transmission from the beginning of that block after confirming that all data within the block can be transmitted successfully. In this way, ECM guarantees that a good image can be received at the receiving end. ECM is very effective in countries where the telephone lines are in poor condition. There may be occasions when you want to turn ECM off. For instance, when you feel the transaction speed is extremely slow, you can turn ECM off.

## F

**FINE**

Use this setting for documents with very small characters and lines. It is twice the STANDARD resolution.

## G

**G3**

Group 3 fax machines defined by CCITT. Uses encoding schemes to transmit image data while reducing the amount of data that needs to be transmitted, thus reducing transmission time. G3 fax machines can transmit one page in less than one minute. Encoding schemes for G3 fax machines are Modified Huffman (MH), Modified Read (MR), Modified Modified Read (MMR), and JBIG.

**Group dial**

Group Dialling allows you to dial up to 199 previously registered One-touch Speed Dialling or Coded Speed Dialling numbers together as a group. This means you only need to press a One-touch speed dial button or the CODED DIAL button followed by a three-digit code to dial a large group of numbers automatically. You register each group of facsimile numbers for a One-touch or Coded Speed Dialling button, so make sure a button is available before trying to register Group Dialling. Once a group is defined, you can add or delete numbers to/from the group.

**Group number**

List of all facsimiles to receive a relayed document. These are two-digit codes between 00-99. The group number is registered on the facsimile with the relay feature.

**I****IN USE lamp**

Lights when the telephone line is in use.

**J****Jack**

The telephone line receptacles on your wall and on the side of your fax unit used to connect your fax machine to the telephone line and handset or extension phone.

**L****Long distance dialling**

When dialling or registering long-distance numbers, you sometimes have to insert a pause either within or after the telephone number. The destination and length of the pause differ depending on the system. Contact your local authorized Canon dealer or your local telephone company for further information if you experience problems with long distance dialling.

**M****Manual receiving**

Use this setting if you have installed the optional handset kit and there is only one line connected to your office which you use for both phone and fax communication, and you want to monitor all incoming calls yourself. When you hear the ringer, pick up the handset and answer the phone. If you hear a slow beep, this means someone is trying to send you a facsimile transmission. Press START/SCAN and hang up the handset to start receiving the document. You can not receive documents if there is another document fed into the fax.

**Manual redialling**

When you use regular dialling, you can redial a number manually simply by pressing REDIAL on the operation panel. The last number called is the number re-dialled.

**Manual sending**

Use manual sending when you have installed the optional handset kit or connected an extension phone and you have to talk to the other party before you send the document. You may have to do this to send transmissions to older fax units. Put the document in the fax and then dial the number. After the call connects, if you hear a high-pitched tone, press START/SCAN to send the facsimile and then hang up. If the other party or the other fax does not answer, hang up the handset. If the other party answers, tell him that you are going to send a facsimile transmission and that he should press start button on his own machine. Press START/SCAN on your own fax, then hang up the handset.

**Memory box**

The memory box provides features that allow you to set up an ITU-T subaddress and password and allows you to use advanced features such as confidential sending and relay sending with fax units of any manufacture as long as they too support ITU-T standard subaddress/password transactions.

**Memory broadcast**

Allows you to send one scanned document to a maximum of 210 destinations with One-touch Dialling, Coded Speed Dialling, and regular dialling. Just dial the numbers sequentially when you send a document. If you must do this frequently, register the numbers for Group Dialling.

**Memory file**

A document stored in the memory is also called a *memory file*.

**Memory list**

See *document memory list*.

**Memory lock**

Usually a document is printed as soon as it is received, but the memory lock feature forces all documents to be received in memory until you enter a password to print them. This feature prevents printed documents from piling up on the paper output tray when the office is unattended. After you return to the office, you can print all documents stored in the memory.

**Memory reception password**

Protects all documents received and stored in the memory when the memory reception feature is turned on. The memory reception password is a four-digit number (0000-9999) that you should safeguard to prevent access to your documents stored in the fax memory. This password unlocks the memory to print all documents received with memory lock turned on. See *memory lock*.



**Memory sending**

Scanning the document into the memory before the facsimile dials the number and sends it. Scanning is fast and you only have to wait until the original document is scanned, not until it is sent. You can get the original back much faster and spend less time standing around the fax.

**Multitranaction**

Also called, *multiple transmission* or *sequential broadcast*, this term refers to scanning a document once and sending it to more than one location. You can send a single document to a maximum of 210 destinations.

## N

**Noise**

A general term applied to a number of problems that adversely affect the operation of telephone lines used for modem and fax communication.

**Normal mode**

Using the fax with its default settings.

**Numeric buttons**

The numeric buttons are the round buttons on the operation panel marked the same as a standard telephone keypad. Press to perform regular dialling. The numeric buttons are also used to enter numbers and letters when registering numbers and names.

## O

**One-touch Speed Dialling**

Each One-touch Speed Dialling button holds a facsimile telephone number. After the numbers are registered, all you have to do is press one button to dial. Up to 72 numbers can be registered for One-touch Speed Dialling.

## P

**PAUSE**

By pressing PAUSE, you can enter a pause between digits of a telephone number when you register the number for One-touch or Coded Speed Dialling or during regular dialling. A pause may be required for a connection to an outside line, or some countries may require a pause for overseas fax transmission.

**Pause time**

When registering long-distance numbers, you sometimes have to insert a pause either within or after the number. The destination of the pause and pause time depend on the system. Pauses entered within a number are 2 seconds long, and a pause at the end of a number is 10 seconds. A pause is inserted in a number or at the end of a number by pressing the PAUSE button. The PAUSE button is factory preset to enter a 2 second pause within a number, although this may differ according to your location. Pauses entered after a number are always fixed at 10 seconds. If you adjust the pause time, this only changes the length of the pauses inserted within numbers and does not affect pauses entered at the end of numbers.

**PBX**

Stands for *private branch exchange*. A PBX controls the flow of telephone traffic through the institution itself, including automatic call back and dialling and paging systems. See *switchboard*.

**Polling transmission**

Polling means one facsimile unit requests another to send a document. This is useful when the sending party, the party with the original document, is not in the office, but the document must be sent out. The receiving party dials the fax holding the original and requests that it be sent. In other words, the receiver always polls the sender. Before using the polling feature, you have to set up polling boxes.

**Printable area**

The area of the document that can actually be reproduced and printed on the recording paper by the receiving fax. The printing area is smaller than the paper.

**Pulse**

See *rotary pulse*.

## R

**Reduction mode**

The fax unit's automatic feature that slightly reduces the received image to allow room at the top of the page for the sender's ID information. You can also reduce the size of large incoming documents using the RX REDUCTION option.

**Registering**

A process by which you place fax or telephone numbers and names in the fax unit's memory for automatic dialling so that you can save time dialling frequently called destinations.

**Regular dialling**

Dialling a number with the numeric buttons. Use regular dialling to dial a number that is not registered for any of the automatic dialling methods. Press HOOK then use the numeric buttons to dial the number you want to call.

**Relay broadcast**

See *relay sending*

**Relay sending**

Also called *relay broadcast*. You can send a document once to a fax in a distant location and then have that fax relay your document to several other destinations in the same area.

**Remote receiving ID**

The number you dial on an extension to start receiving a fax. The default remote receiving ID is 25, so just dial 25 and then hang up the handset of the extension telephone.

**Remote reception**

Allows you to receive a fax transmission with an extension telephone. To start receiving a fax, dial the remote receiving ID (25). You can also set the fax to start receiving by hanging up.

**Reports**

This is a list of reports printed by the facsimile:

- **Activity Management Report (TX or RX)** You can set the fax to print a report every time you send or receive a document. You can also set the fax to print part of the document on the report to remind you of the content of the document. To turn printing these activity reports on and off, use the user settings.
- **Activity Report** Provides a record of the last 40 sending and receiving transactions. You can print out activity management reports manually whenever you want to review the last 40 transactions, set the fax up to print them automatically after every 40 transactions, print the report at the same time every day, or print the report showing the sending transactions of individuals or departments in your company, using department codes registered on the fax, as well as a list of receptions.
- **Confidential RX Report** After you receive a confidential document in a mailbox, the fax prints out a confidential message notice. No special settings are required. Each notice shows the date and time you received the confidential document, the name and telephone number of the party sending the confidential document, whether the document was successfully received, and other useful information.
- **Error TX Report** If the fax fails to send a document because the other party does not answer, even after automatic redialling, or if an error occurs, then your fax will immediately print an error transmission report. The report includes the facsimile number of the other party so you can try sending again and can print part of the first page of the document so you can identify it.
- **Memory Clear Report** When documents are stored in the memory if power to the fax is cut off for more than 12 hours, the documents stored in the memory will be erased. After power is restored, a Memory Clear List will print to show you what documents have been erased. If power is restored within 12 hours, the documents are not erased and no report prints.

- **Multi TX/RX Report** When you send a document to more than one destination, the fax prints a report to show you the name and numbers of the other parties, whether the transactions were completed or not, and errors if any. The fax automatically prints multi-transaction reports for sending documents to more than one destination, delayed sending documents to more than one destination, sending documents through a relay fax to more than one destination, and sending confidential documents to more than one destination if the mailboxes are the same on every fax unit.
- **Relay Broadcast Report** After sending a document through a relay fax, you may receive a relay broadcast report from the fax machine that relayed the document. This shows whether or not the document was successfully relayed to all the final destinations. To receive a report, the other machine must be set to print a relay broadcast report.

### **Resolution**

The density of dots for an output device like a fax, scanner, or printer. Expressed in terms of dots per inch (dpi). Low resolution causes font characters and graphics to have a jagged appearance. Higher resolution means smoother curves and angles as well as a better match to traditional typeface designs. Resolution values are represented by horizontal data and vertical data, for example, 600 x 600 dpi.

### **Restricted reception**

The ability of the fax unit to restrict incoming documents. With this feature turned on, the fax unit will receive documents only from speed dialling numbers registered in your fax unit.

### **Rotary pulse**

A *rotary-pulse* or *pulse dial* telephone is dialled by manually rotating a dial to send pulses to the telephone switching system. When you pulse dial, you will hear clicks. With tone dialling, you will hear tones.

### **RX password**

The ITU-T password set on your fax to match the ITU-T password of all incoming documents. If your RX password matches the ITU-T password of the incoming transmission, the document is received. If the passwords do not match, the document is not received. The maximum length of the password is 20 digits and may consist of numbers, spaces, asterisk (\*), and pound mark (#).

## **S**

### **Scanning area**

The scanning area is narrower than the original document size on the entire border around the document. Documents you send should have some margin on the sides and the top and bottom. Anything over this margin can not be scanned for sending.

**Sender's name**

Name or company name, your fax number, date and time the document sent to the receiving party are printed on each page you send. The sender's name, which is your own name can be printed on the documents that you send. You can register up to 99 sender names that can be selected with the TTI selector before sending. Your name and facsimile number are printed at the top of documents that you send.

**Sending speed**

The rate at which documents are sent over the phone line. See also *bps*.

**Sequential broadcast**

Allows you to send one scanned document to up to 210 destinations by using One-touch Speed Dialling, Coded Speed Dialling, and regular dialling. You just dial several numbers to send the document. If you do this frequently, you should register the numbers for *Group Dialling*.

**Smoothing**

Even if the image you receive from the other party's fax is of poor quality, your fax unit will smooth the image to produce a better quality image.

**Stamp**

The optional stamp feature marks documents that have been scanned for transmission with a yellow circle stamped on the lower left side of the document.

**STANDARD**

Use this setting to send normal, typewritten or printed documents containing only text and no drawings, photographs, or illustrations.

**Standby**

On and ready to use. All operations start from the standby mode where the date and time are displayed.

**SUPER FINE**

This button increases the clarity of documents you send. The lamp shows you the current setting. It is four times the STANDARD resolution.

**Switchboard**

Also called a PBX (private branch exchange) internal switching system. You have to dial an outside line number along with the regular facsimile telephone number. The outside line number must also be registered. Depending on the system, you may also have to insert a pause after the outside line number. The pause button is factory preset to enter a 2-second pause. However, you can change the pause time to suit your PBX or telephone system. Before adjusting the pause time, check with your local authorized Canon dealer or your local telephone company about the correct pause time to use for your telephone system.

# T

## **Timed sending**

See *delayed transmission*.

## **Tone/pulse setting**

This setting allows you to set the fax to touch tone (T) or pulse (P) dialling, depending on the type of phone line you have installed.

## **TONE**

You can switch temporarily from pulse to tone dialling by pressing TONE/+ before dialling. Data services may require that you use tone dialling, so if you have a conventional pulse dial telephone and need to use tone dial to access the data service, press TONE/+ to tone dial on your pulse telephone line.

## **Toner cartridge**

Your fax machine uses a patented FX4 cartridge which contains both the photosensitive drum and toner in one compact unit. For details about disposing of used toner cartridges, contact your local dealer or authorized Canon representative.

## **Touch-tone**

A *touch-tone* or *tone dial* telephone is dialled by pressing buttons that send tones of varying pitch to the telephone switching system.

## **Transaction number**

When a document is scanned into or received in the memory, it is assigned a transaction number (TX/RX). You can select documents in the memory for sending, printing, or deleting by specifying the transaction number.

## **Transfer**

A special feature you can set up on the fax to have all documents received on the main fax unit transferred to another fax unit. For example, you could have the main fax unit in the office transfer all documents to your fax at home. You can set the day and time for this feature to turn on and off. Please remember, however, that documents received in a confidential mailbox or a memory box can not be transferred. See *transfer password*.

## **Transfer password**

Protects the transfer settings from unauthorized access. You must enter the transfer password, a four-digit code (0000-9999), in order to view or change the transfer settings.

## **Transmission time**

A fax transmission consists of three stages: the pre-message handshake, the message transmission, and the post-message handshake. The transmission time described in this user's guide is not the total time required for the entire transmission. It is only the time for the message transmission. The transmission time described in this user's guide is the fastest time achieved when faxes communicate in the same mode.

**TTI**

Stands for *transmit terminal identification*. Also called sender information. The TTI is the name of the person or organisation and the facsimile number of the fax that sends a document. In addition to a unit name that you register for the fax, you can create up to 99 sender names that can be selected and used in place of the unit name when you send a facsimile transmission.

**TTI SELECTOR**

With this feature you can select the name to be printed at the top of the message you send. Usually you register your company name as the TTI, but you can also use personal names.

**TX password**

The ITU-T password set on your fax that accompanies the document you send and must match the RX password on the fax where it is received. If your TX password matches the RX password of the other party's fax, the document is received. If the passwords do not match, the document is not received. The maximum length of the password is 20 digits and may consist of numbers, spaces, asterisk (\*), and pound mark (#).

**U****UHQ**

Stands for *ultra high quality* image. Allows you to send documents that are very close to the quality of the original.

**Urgent document**

Use direct sending to send an urgent document ahead of documents in the memory waiting to be sent. Just feed the urgent document into the facsimile and dial, and press DIRECT TX. As soon as the facsimile finishes sending the current document from the memory, it will send the urgent document. See also *direct sending*.





## A

- Activity Management Report
  - sample, 14-8
- Activity Management Report (TX/RX)
  - separate
    - sample, 14-8
- Activity Report (RX)
  - sample, 14-13
- Activity Report (TX)
  - sample, 14-10
- Activity Report (TX) with image
  - sample, 14-11
- Activity Reports
  - printing, 14-7
- automatic document feeder (ADF)
  - load limit, 6-4
  - setting document for copying, 5-2
  - setting document for sending, 6-3
- automatic redialling
  - described, 6-16

## B

- batch sending
  - function, 4-9, 4-17, 4-25, 16-10

## C

- CHECK PRINTER COVER
  - displayed at power on, 2-28
- cleaning
  - fax unit, 15-18
  - Opening operation panel, 15-19
  - scanning area, 15-22
- closed network
  - creating, 13-14
- Coded Speed Dial List
  - sample, 14-3, 14-4

- Coded Speed Dialling
  - defined, 4-5
  - entering a name, 4-16
  - entering number, 4-15
  - registering for Group Dialling, 4-23
  - setting timer, 4-17
  - setting transmission speed, 4-20
  - setting up, 4-14
  - turning ECM on/off, 4-21
  - using, 4-28
- confidential documents
  - cancelling mailbox, 10-6
  - creating mailbox, 10-2
  - receiving, 10-7
  - sending, 10-9
  - sending with speed dialling, 10-9
- confidential mailbox
  - changing mailbox settings, 10-5
  - setting, 16-17
- confidential Mailbox List
  - sample, 14-15
- confidential Receive Report
  - CONFID. RX REPORT, 16-8
  - sample, 14-13
- CONTRAST
  - setting for sending, 6-5
  - settings for copying, 5-5
- copying
  - checking document, 5-2
  - contrast, 5-5
  - document, 5-2
  - document settings, 5-4
  - document type, 5-5
  - procedure, 5-5
  - resolution, 5-5
  - setting document, 5-3
  - with restrictions on, 13-11

## D

- D.T. button
  - confirming dial tone, 4-4
  - PROGRAM button, 12-5

- data registration
  - entering a name, 3-7
  - entering text/numbers, 3-7
  - menu, 16-2
  - sender information, 3-11
- date
  - format, 16-25
  - registering, 3-13
  - setting, 16-4
- date and time
  - registering, 3-13
- DATE SETUP
  - format setting, 16-25
- defaults
  - defined, 2-2
  - listed, 12-10
- delayed sending
  - setting, 6-21
  - setting timer, 6-21
- density
  - control, 16-5
  - SELECT DENSITY, 16-16
- Department Access Code Report
  - sample, 14-9
- dial tone
  - confirming, 4-4
  - registering number for, 4-4
- dialling
  - Coded Speed Dialling, 4-14, 4-28
  - directory dialling, 4-31
  - entering pauses, 4-2
  - Group Dialling, 4-22, 4-29, 4-31
  - long distance, 6-9
  - One-touch Speed Dialling, 4-6, 4-26
  - regular dialling, 6-7
  - speed dialling, 4-5, 4-26
  - speed dialling methods, 4-5
  - tone dialling on pulse line, 12-3
- direct sending
  - described, 6-13
  - procedure, 6-14
- directory dialling
  - using, 4-31
- DISPLAY LANGUAGE
  - setting, 16-26
- document
  - check before loading for sending, 6-2
  - copying, 5-2
  - defined, 2-2

- deleting with DELETE FILE button, 8-9
- deleting with MEMORY REFERENCE button, 8-9
- erasing from memory, 8-8
- jam, 15-2
- receiving large size, 16-15
- removing document jams, 15-2
- scanning for polling sending, 11-17
- SELECT CASSETTE, 16-15
- setting for copying, 5-3
- setting for sending, 6-2
- settings for copying, 5-4

document tray

- attaching, 2-20

DOCUMENT TYPE

- setting for sending, 6-5
- settings for copying, 5-5

## **E**

ECM

- turning on/off for Coded Speed Dialling, 4-21
- turning on/off for One-touch Speed Dialling, 4-13

ENERGY SAVER

- setting, 16-26

ENERGY SAVER button

- using, 3-21

energy saver mode

- ENERGY SAVER button, 3-21
- returning to full power, 3-21
- turning on, 3-19
- using, 3-19

entry mode

- changing, 3-7
- LCD display, 3-7
- number, 3-8
- text, 3-8

error messages

- listed alphabetically, 15-26
- listed by number, 15-24

Error Report (RX)

- sample, 14-12

Error Report (TX)

- sample, 14-9

extension phone

- connecting, 2-22
- receiving with, 7-7

## F

### fax unit

- assembling, 2-17
- front view, 2-11
- lifting, 2-8
- parts, 2-11
- rear view, 2-12

### FILE SETTINGS

- CONFID. MAILBOX, 16-17
  - described, 16-3
  - listed, 16-17
- MEMORY BOX, 16-18
- POLLING BOX, 16-21
- PRESET POLLING, 16-20
- RELAY TX GROUP, 16-18
- TRANSFER, 16-22

### front paper cassette

- inserting in fax unit, 2-26
- loading, 2-25
- removing lock plate, 2-15

## G

### Group Dial List

- sample, 14-4

### Group Dialling

- defined, 4-5
- registering for Coded Speed Dialling
  - button, 4-23, 4-24
- registering for One-touch Speed Dialling
  - button, 4-23
- setting timer, 4-24
- setting up, 4-22
- using, 4-29

## H

### handset (option)

- connecting, 2-20
- required for manual receiving, 7-6
- using, 12-2
- using for sending, 6-10
- using with restrictions on, 13-12
- view, 2-12

## I

### ITU-T password

- memory box, 8-10
- sending document, 6-24

### ITU-T subaddress

- memory box, 8-10
- sending document, 6-24

## J

### jam

- document feed, 15-2
- printer feed, 15-3

## L

### language

- switching, 16-26

### location

- choosing, 2-3
- ideal temperature, 2-3
- space around fax unit, 2-5

### long distance

- setting for Coded Speed Dialling, 4-20
- setting for One-touch Speed dialling, 4-12

## M

### manual receiving

- manual/auto switching, 16-12
- procedure, 7-6
- setting auto switch time, 7-4
- settings, 7-6

### manual sending

- described, 6-15
- procedure, 6-15

### memory

- creating memory box, 8-10
- deleting document, 8-9
- erasing document, 8-8
- erasing document in memory, 6-17
- locking to receive all documents, 13-15
- power failure, 8-24
- printing document in memory, 8-5
- printing memory list, 8-4
- re-sending document in memory, 6-17
- re-sending to different destination, 8-7
- re-sending to same destination, 8-6
- sending with memory full, 6-14

- memory box
  - cancelling, 8-21
  - changing settings, 8-19
  - creating, 8-10, 8-11, 8-13
  - ITU-T subaddress/password, 8-10
  - preparation for setting up, 8-11
  - printing document from, 8-23
  - sending document, 8-22
  - setting, 16-18
  - setup summary, 8-15
- Memory Box Report
  - sample, 14-14
- Memory Clear Report
  - sample, 14-17
- memory list
  - printing, 8-4
- memory lock
  - described, 13-15
  - MEMORY LOCK RX, 16-25
  - setting password, 13-15
  - setting time, 13-15
  - summary settings, 13-17
  - turning on, 13-18
- MEMORY LOCK RX
  - setting, 16-25
- memory sending
  - described, 6-11
  - procedure, 6-11
- menu
  - button summary, 3-8
  - defined, 2-2
  - Opening, 3-6
  - returning to previous level, 3-6
  - using, 3-5
- mode
  - changing entry mode, 3-7
- Multi-transaction Report
  - sample, 14-12

## **N**

- numeric keypad buttons
  - entering text/numbers, 3-7
  - summary, 3-8

## **O**

- One-Touch Speed Dial List 1
  - sample, 14-3
- One-touch Speed Dialling
  - defined, 4-5
  - registering for Group Dialling, 4-23
  - setting for long distance, 4-12
  - setting time, 4-9
  - setting transmission speed, 4-12
  - setting up, 4-6
  - turning ECM on/off, 4-13
  - using, 4-26
- One-Touch Speed Dialling List 2
  - sample, 14-4
- Operation panel
  - buttons, 3-2, 3-4
  - Opening, 15-19
  - using, 3-5
- Output tray
  - attaching, 2-20

## **P**

- paper
  - loading, 2-22
  - loading front paper cassette, 2-25
  - storing, 15-13
- paper jams
  - avoiding, 2-8
- pauses
  - adjusting length, 4-3
  - entering for dialling, 4-2
  - MID PAUSE SET, 16-9
- PHONE NO. CHECK
  - setting, 16-26
- polling
  - before polling receiving, 11-2
  - before polling to send, 11-13
  - cancelling polling box setup, 11-20
  - cancelling preset polling, 11-12
  - changing polling box setup, 11-19
  - changing preset settings, 11-11
  - creating polling box, 11-13
  - described, 11-2
  - preset, 11-5
  - scanning document for sending, 11-17
  - sending, 11-13
  - timer, 11-5
  - to receive, 11-3
  - to receive at set time, 11-5

POLLING BOX  
 setting, 16-21

power  
 backup battery, 8-25  
 connection, 2-6  
 failure and memory, 8-24  
 required, 2-6  
 turning on power, 2-27

PRESET POLLING  
 setting, 16-20

PRINT REPORT  
 PROGRAM button, 12-5

printer cover  
 closing, 2-19

PRINTER SETTINGS  
 # OF RX COPIES, 16-15  
 described, 16-3  
 listed, 16-14  
 PRINT IN ORDER, 16-16  
 RX REDUCTION, 16-15  
 SELECT CASSETTE, 16-15  
 SELECT DENSITY, 16-16  
 TONER SUPPLY, 16-16

printing  
 Activity Reports, 14-7  
 document in memory, 8-5  
 document in memory box, 8-23  
 documents locked in memory, 13-18  
 lists, 14-1  
 memory list, 8-4  
 paper supply source for reports, 16-8  
 PRINT IN ORDER, 16-16  
 removing jams, 15-3  
 report, 16-5  
 reports, 14-1  
 reports with restrictions on, 13-11  
 sender names, 14-6  
 TONER SUPPLY low, 16-16  
 User Data List, 14-5

PROGRAM button  
 D.T. function, 12-5  
 PRINT REPORT function, 12-5  
 REPORT function, 12-5  
 SCANNING MODE function, 12-5  
 setting up, 12-4  
 STAMP function, 12-5  
 TONE function, 12-5

pulse dial  
 setting, 3-10

## R

R button  
 See "R-KEY", 4-2

R-KEY  
 USER SETTINGS, 16-6

R-KEY (R-KEY)  
 function, 4-2  
 See "RX REPORT", 16-7

RECEIVED IN MEMORY  
 message, 8-2

Received Memory Box List  
 sample, 14-16

receiving  
 all documents in memory, 13-15  
 auto switch time, 7-4  
 automatically, 7-2  
 cancelling, 7-10  
 confidential documents, 10-7  
 manually, 7-6  
 memory receiving, 16-13  
 MEMORY RX, 16-13  
 messages, 7-2  
 password, 16-26  
 polling, 11-3  
 remote, 7-7  
 REMOTE RECEIVING, 16-13  
 RX REDUCTION, 16-15  
 setting receive mode, 7-2  
 start speed, 16-26  
 transferring documents, 7-11

recording paper  
 see "paper", 2-22  
 storing, 15-13

redial  
 AUTO REDIAL, 16-10

redialling  
 automatic, 6-16  
 cancelling, 6-17  
 line busy, 6-16  
 setting up, 6-18  
 setup summary, 6-19

registering  
 correcting, 3-16  
 date and time, 3-13  
 making corrections, 3-16  
 sender information, 3-13  
 sender names, 3-17  
 unit name, 3-15  
 unit telephone number, 3-14

- regular dialling
    - long distance, 6-9
  - regular transmissionsetting for Coded Speed Dialling, 4-19
    - setting for One-touch Speed Dialling, 4-11
  - Relay Broadcast Report
    - sample, 14-14
  - RELAY TX GROUP
    - setting, 16-18
  - relaying documents
    - changing relay settings, 9-6
    - deleting relay group, 9-7
    - described, 9-2
    - sending to relay unit, 9-8
    - sending with speed dialling, 9-9
    - setting your fax as relay unit, 9-3
    - summary of settings, 9-4
    - using RELAY BROADCAST button, 9-10
  - remote receiving
    - changing ID, 7-8
    - with extension phone, 7-7
  - REPLACE CARTRIDGEdisplayed at power on, 2-28
  - REPORT
    - PROGRAM button, 12-5
  - REPORT SETTINGS
    - activity report, 16-8
    - confidential RX report, 16-8
    - described, 16-3
    - listed, 16-7
    - memory box report, 16-8
    - print report where, 16-8
    - RX report, 16-7
    - TX report, 16-7
  - reports
    - Activity Management Report sample, 14-8
    - Activity Report (RX) sample, 14-13
    - Activity Report (TX) sample, 14-10
    - Activity Report (TX) with image sample, 14-11
    - Activity Report (TX/RX separate) sample, 14-8
    - Activity Reports, 14-7
    - Coded Speed Dial List 1 sample, 14-3
    - Coded Speed Dial List 2 sample, 14-4
    - Confidential Mailbox List sample, 14-15
    - Confidential Receive Report sample, 14-13
    - Department Access Code Report sample, 14-9
    - Error Report (RX) sample, 14-12
    - Error Report (TX) sample, 14-9
    - Group Dial List sample, 14-4
    - Memory Box Report sample, 14-14
    - Memory Clear Report sample, 14-17
    - Multi-transaction Report sample, 14-12
    - One-touch Speed Dial List 1 sample, 14-3
    - One-touch Speed Dialling List 2 sample, 14-4
    - paper supply source, 16-8
    - Received Memory Box List sample, 14-16
    - Relay Broadcast Report sample, 14-14
    - Sender Name List sample, 14-6
    - sender names, 14-6
    - speed dialling lists, 14-2
    - User Data List, 14-5
    - User's Data List sample, 14-5
  - RESOLUTION
    - scan resolution setting, 16-5
    - setting for sending, 6-5
    - settings for copying, 5-5
    - super fine, 16-5
    - ultra fine, 16-5
  - RESTRICTIVE CODES
    - setting, 16-24
  - RX footer
    - illustrated, 3-12
  - RX PASSWORD
    - setting, 16-26
  - RX SETTINGS
    - described, 16-3
    - ECM RX, 16-12
    - listed, 16-12
    - MAN/AUTO SWITCH, 16-12
    - MEMORY RX, 16-13
    - REMOTE RX, 16-13
    - RX PAGE FOOTER, 16-13
  - RX START SPEED
    - setting, 16-26
- ## S
- safety
    - area around fax unit, 2-7
    - electrical storms, 2-7
    - handling power cord, 2-7
    - power cord, 2-8
  - SCANNING MODE
    - PROGRAM button, 12-5

- search
  - name/number from directory, 4-31
- search buttons
  - defined, 2-2
- security
  - closed network, 13-14
  - copying, 13-11
  - Operating fax with restrictions on, 13-9
  - printing reports, 13-11
  - restricting fax operation, 13-5
  - sending document with restriction, 13-9
  - setting restrictions on use of fax, 13-5
  - system password, 13-2
  - turning restrictions off/on, 13-12
  - using handset (option) with restrictions on, 13-12
- send report
  - See "TX REPORT", 16-7
- send settings
  - AUTO REDIAL, 16-10
  - BATCH TX, 16-10
  - ECM TX, 16-9
  - ERASE FAILED TX, 16-10
  - listed, 16-9
  - MID PAUSE SET, 16-9
  - QUICK ON-LINE TX, 16-10
  - STAMP ACTION (option), 16-11
  - TIME OUT, 16-11
- sender information
  - defined, 3-12
  - registering, 3-13
  - RX footer, 3-12
  - RX PAGE FOOTER, 16-13
  - setting, 3-11
  - unit name, 16-4
  - unit telephone number, 16-4
- Sender Name List
  - sample, 14-6
- sender names
  - changing, 3-18
  - deleting, 3-19
  - printing list, 14-6
  - registering, 3-17
  - selecting before sending, 6-6
- sender's name
  - setting, 16-4
- sending
  - adjusting scanning settings, 6-4
  - BATCH TX, 16-10
  - cancelling, 6-8
  - confidential document with speed dialling, 10-9
  - confidential documents, 10-9
  - contrast, 6-5
  - direct sending, 6-13
  - document from memory box, 8-22
  - document to relay unit, 9-8
  - document type, 6-5
  - document with restrictions on, 13-9
  - erase failed transmission, 16-10
  - manual sending, 6-15
  - memory box, 8-22
  - memory full, 6-14
  - memory sending, 6-11
  - more than one location, 6-20
  - polling, 11-13
  - preparing document, 6-2
  - QUICK ON-LINE TX, 16-10
  - re- sending document in memory, 6-17
  - re-sending to different destination, 8-7
  - re-sending to same destination, 8-6
  - regular dialling, 6-7
  - relaying document with speed dialling, 9-9
  - resolution, 6-5
  - selecting sender name, 6-6
  - sequential broadcasting, 6-20
  - setting document on fax, 6-3
  - setting timer, 6-21
  - start speed, 16-26
  - with ITU-T password, 6-24
  - with ITU-T subaddress, 6-24
- sequential broadcasting
  - sending to more than one location, 6-20
- setting up
  - assembling fax unit, 2-17
  - attaching trays, 2-20
  - connecting extension phone, 2-22
  - connecting handset (option), 2-20
  - connecting telephone line, 2-21
  - installing toner cartridge, 2-17
  - loading front paper cassette, 2-25
  - loading paper, 2-22
  - loading side paper cassette, 2-23
  - power on, 2-27
  - removing lock plates, 2-15
  - removing shipping material, 2-13

- shipping material
  - removing, 2-13
- side paper cassette
  - adjusting for paper size, 2-23
  - inserting in fax unit, 2-25
  - loading, 2-23
- speed dialling
  - Coded Speed Dialling, 4-5, 4-28
  - D.T. button registration, 4-4
  - Group Dialling, 4-5, 4-29
  - ITU-T subaddress/password, 6-24
  - lists, 14-2
  - methods, 4-5
  - One-touch Speed Dialling, 4-5, 4-26
  - sending confidential documents, 10-9
  - sending relaying documents, 9-9
  - using, 4-26
- STAMP**
  - PROGRAM button, 12-5
- stamp (option)
  - described, 12-7
  - re-filling ink pad, 15-23
  - setting, 16-11
  - setting up, 12-7
- super fine
  - setting, 6-5, 16-5
- SUPPLY REC. PAPER**
  - displayed at power on, 2-28
- system password
  - cancelling, 13-3
  - changing, 13-3
  - setting, 13-2, 16-24
- SYSTEM SETTINGS**
  - DATE SETUP, 16-25
  - described, 16-3
  - DISPLAY LANGUAGE, 16-26
  - ENERGY SAVER, 16-26
  - listed, 16-23
  - MEMORY LOCK RX, 16-25
  - PASSWORD (system password), 16-24
  - PHONE NO. CHECK, 16-26
  - RESTRICTIVE CODES, 16-24
  - RX PASSWORD, 16-26
  - RX RESTRICTION, 16-25
  - RX START SPEED, 16-26
  - TX START SPEED, 16-26

## T

- telephone line
  - connecting, 2-21
  - jack required, 2-4
  - selecting type, 16-6
  - switching, 3-10
- temperature
  - fax unit location, 2-3
- timer
  - registering, 3-13
  - set for polling, 11-5
  - setting, 16-4
  - setting for Coded Speed Dialling, 4-17
  - setting for Group Dialling, 4-24
  - setting for One-touch Speed Dialling, 4-9
  - setting for sending, 6-21
- TONE**
  - PROGRAM button, 12-5
- tone dial
  - setting, 3-10
- toner cartridge
  - handling, 2-18, 15-17
  - installing new, 2-17
  - protecting, 2-8
  - removing seal, 2-18
  - replacing, 15-14
  - storing, 15-17, 15-18
- transaction history
  - displaying, 8-3
- transaction number
  - assigned to every transaction, 6-12
  - defined, 2-2
  - LCD display, 6-12
  - receiving, 7-2
  - transaction history, 8-3
- TRANSFER**
  - setting, 16-22
- transferring document reception
  - cancelling, 7-17
  - changing settings, 7-16
  - setting up, 7-12
  - summary table of settings, 7-13
  - turning off, 7-15
  - turning on, 7-15
  - turning on/off, 7-15



transmission report  
  See “TX REPORT”, 16-7  
transmission speed  
  setting for Coded Speed dialling, 4-20  
  setting for One-touch Speed Dialling, 4-12  
troubleshooting  
  questions and answers, 15-30  
TX SETTINGS  
  described, 16-3  
  see “Send Settings”, 16-9  
TX START SPEED  
  setting, 16-26

## **U**

ultra fine  
  setting, 6-5, 16-5  
unit name  
  registering, 3-15  
unit telephone number  
  registering, 3-14  
unpacking  
  box contents, 2-9, 2-10

User Data List  
  printing, 14-5  
user data settings  
  summary, 16-3  
USER SETTINGS  
  DATE & TIME, 16-4  
  DENSITY CONTROL, 16-5  
  described, 16-3  
  listed, 16-4  
  OFFHOOK ALARM, 16-6  
  PROGRAM key, 16-5  
  R-KEY SETTINGS, 16-6  
  SCAN RESOLUTION, 16-5  
  SENDER’S NAME, 16-4  
  TELEPHONE LINE TYPE, 16-6  
  TX TERMINAL ID, 16-5  
  UNIT NAME, 16-4  
  UNIT TELEPHONE #, 16-4  
  VOLUME CONTROL, 16-6  
User’s Data List  
  sample, 14-5



## Free Manuals Download Website

<http://myh66.com>

<http://usermanuals.us>

<http://www.somanuals.com>

<http://www.4manuals.cc>

<http://www.manual-lib.com>

<http://www.404manual.com>

<http://www.luxmanual.com>

<http://aubethermostatmanual.com>

Golf course search by state

<http://golfingnear.com>

Email search by domain

<http://emailbydomain.com>

Auto manuals search

<http://auto.somanuals.com>

TV manuals search

<http://tv.somanuals.com>