

# Installation, Start-Up and Service Instructions

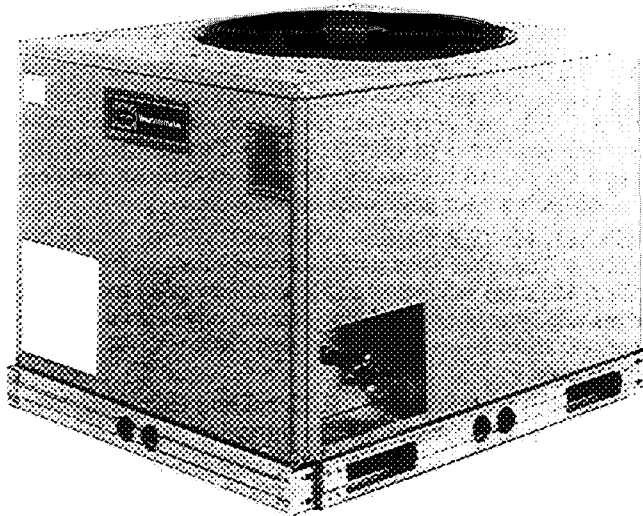

### SAFETY CONSIDERATIONS

Installing and servicing air-conditioning equipment can be hazardous due to system pressure and electrical components. Only trained and qualified service personnel should install or service air-conditioning equipment.

When working on air-conditioning equipment, observe precautions in literature and on tags and labels attached to unit.

Follow all safety codes. Wear safety glasses and work gloves. Use quenching cloth for brazing operations. Have fire extinguisher available. Read these instructions *thoroughly*. Consult local building codes and National Electrical Code (NEC) for special installation requirements.

#### ▲ WARNING

Before installing or servicing system, always turn off main power to system. There may be more than one disconnect switch. Electrical shock can cause personal injury.

### INSTALLATION

#### Step 1 – Complete Pre-Installation Checks

**UNCRATE UNIT** — Remove unit packaging except for the top skid assembly and wood bumpers, which should be left in place until after unit is rigged into place.

**INSPECT SHIPMENT** — File claim with shipping company if shipment is damaged or incomplete.

#### CONSIDER SYSTEM REQUIREMENTS

- Consult local building codes and NEC for special installation requirements.
- Allow sufficient space for airflow clearance, wiring, refrigerant piping, and servicing unit. See Fig. 1 and Table 1.
- Locate unit so that condenser airflow is unrestricted on all sides and above. Refer to Fig. 1.
- Unit may be mounted on a level pad directly on base rails or mounted on raised pads at support points. See Table 2 for weight distribution based on recommended support points.

**NOTE:** If vibration isolators are required for a particular installation, use data in Table 2 to make proper selection.

**Table 1 – Physical Data**

<b>UNIT 38AK</b>	<b>007</b>
<b>OPER WEIGHT (lb)</b>	340
<b>REFRIGERANT*</b>	22
<b>COMPRESSOR Oil (oz)</b>	65
<b>CONDENSER AIR FAN</b>	Propeller; Direct Drive
Number...Rpm 60 Hz	1...850
50 Hz	1.. 708
Diameter (in.)	26
Motor Hp (NEMA)	1/3
Nominal Cfm Total	3800
<b>CONDENSER COIL</b>	
Face Area (sq ft)	12.24
Storage Capacity (lb)†	11.264
<b>CONNECTIONS (sweat)</b>	
Suction (in.)	1 1/8
Liquid (in.)	1/2
<b>CONTROLS</b>	
Pressurestat Settings	
High   Cutout	426 ± 7 psig
Cut-in	320 ± 20 psig
Low    Cutout	7 ± 3 psig
Cut-in	22 ± 5 psig
<b>FUSIBLE PLUG</b>	200 F

\*Unit is factory supplied with holding charge only.

†Storage capacity of condenser coil with coil 80% full of liquid R-22 at 124 F

**Table 2 – Weight Distribution**

UNIT	STD. UNIT WEIGHT		CORNER WEIGHT (A)		CORNER WEIGHT (B)	
	lbs.	kg.	lbs.	kg.	lbs.	kg.
38AK007	340	154	86	39	53	24

UNIT	CORNER WEIGHT (C)		CORNER WEIGHT (D)	
	lbs.	kg.	lbs.	kg.
38AK007	77	35	124	56

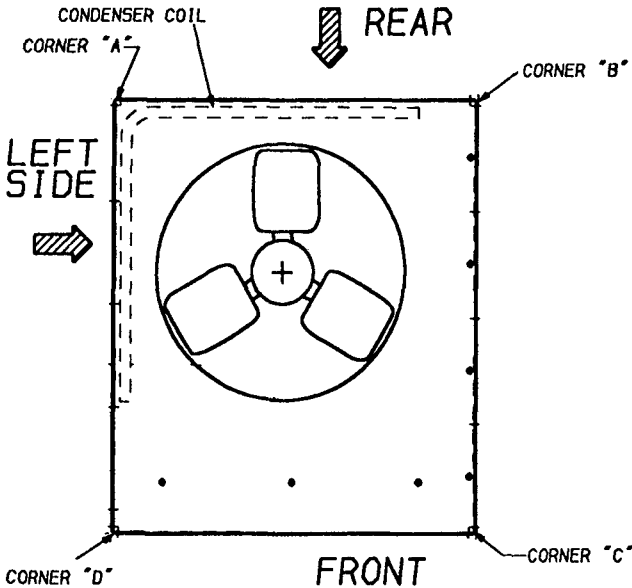

**Step 2 – Rig and Mount the Unit**

**⚠ CAUTION**  
 Be sure unit panels are securely in place prior to rigging.

**RIGGING** — These units are designed for overhead rigging. Refer to rigging label for preferred rigging method. Spreader bars are not required if top crating is left on unit. All panels must be in place when rigging. (See Fig. 2) As further protection for coil faces, plywood sheets may be placed against sides of unit, behind cables. Run cables to a central suspension point so that angle from the horizontal is not less than 45 degrees. Raise and set unit down carefully.

If it is necessary to roll unit into position, mount unit on rails, using a minimum of 3 rollers. *Apply force to rails, not unit.* If unit is to be skidded into position, place it on a large pad and drag it by the pad. *Do not apply any force to unit.*

Raise from above to lift unit from rails or pad when unit is in final position.

After unit is in position, remove all shipping wrapping and top crating.

**Step 3 – Complete Refrigerant Piping Connections** — Suction connection is 1-1/8-in. sweat with plastic cap; liquid connection is 1/2-in. sweat with plastic cap. Follow standard piping practices.

**REFRIGERANT PIPING SIZES**

COND UNIT	EQUIVALENT LENGTH OF PIPING – FT							
	0-25		26-50		51-75		76-100	
	Line Size (In. OD)							
38AK007	L	S	L	S	L	S	L	S
	1/2	1 1/8	1/2	1 1/8	1/2	1 1/8	1/2	1 1/8

L — Liquid Line S — Suction Line

NOTES:

1. Pipe sizes are based on a 2° F loss for liquid and suction lines
2. Pipe sizes are based on an equivalent length equal to the maximum length of interconnecting piping plus 50 percent for fittings.
3. Charge units with R-22 in accordance with unit installation instructions.

**SIZE REFRIGERANT LINES** — Consider length of piping required between condensing unit and evaporator, amount of liquid lift, and compressor oil return. See Table 3 and also refer to Part 3 of Carrier System Design Manual for design details and line sizing. Refer to evaporator installation instructions for additional information.

**INSTALL FILTER DRIER AND MOISTURE INDICATOR** — The filter drier is factory supplied and field installed. Moisture indicator is a field-installed option and should be installed just after liquid line shutoff valve. *Do not use a receiver;* there is none provided with unit and one should not be used.

NOTE: Unit is shipped with R-22 holding charge. System pressure must be relieved before removing caps.

Pass nitrogen or other inert gas through piping while brazing to prevent formation of copper oxide.

Install field-supplied thermostatic expansion valve to evaporator section. It is recommended that a field supplied liquid line solenoid be positioned in the main liquid line close to the evaporator coil, and wired to close when compressor stops to minimize refrigerant migration during the "OFF" cycle.

**Table 3 – Liquid Line Data**



UNIT 38AK007	MAX ALLOWABLE LIQUID LIFT (ft)	LIQUID LINE	
		Max Allowable Pressure Drop (psi)	Max Allowable Temp Loss (F)
60 Hz	86	7	2
50 Hz	72	7	2

NOTE: Values shown are for units operating at 45 F saturated suction and 95 F entering air

**Step 4 – Make Electrical Connections**

**⚠ WARNING**  
 Unit cabinet must have an uninterrupted, unbroken electrical ground to minimize the possibility of personal injury if an electrical fault should occur. This ground may consist of electrical wire connected to unit ground lug in control compartment, or conduit approved for electrical ground when installed in accordance with NEC ANSI (American National Standards Institute)/NFPA (National Fire Protection Association) 70-1987 and local electrical codes. Failure to follow this warning could result in the installer being liable for personal injury of others.

NOTES:

1. Dimensions in [ ] are in millimeters.
2.  Center of gravity.
3.  Direction of air flow.
4. Minimum clearance (local codes or jurisdiction may prevail):
  - a Bottom to combustible surfaces 0 in.
  - b Condenser coil, for proper air flow, 36 in. one side, 12 in. the other. The side getting the greater clearance is optional.
  - c Overhead, 60 in. to assure proper condenser fan operation.
  - d Between units, control box side, 42 in. per NEC.
  - e Between unit and ungrounded surfaces, control box side, 36 in. per NEC.
  - f Between unit and block or concrete walls and other grounded surfaces, control box side, 42 in. per NEC.
5. With the exception of the clearance for the condenser coil as stated in notes 5a, b, and c, a removable fence or barricade requires no clearance.
6. Units may be installed on combustible floors made from wood or class A, B, or C roof covering material.

CONNECTION SIZES	
A	1 5/8" DIA. [35] FIELD POWER SUPPLY HOLE
B	2" DIA. [51] POWER SUPPLY KNOCK-OUT
C	2 1/2" DIA. [64] POWER SUPPLY KNOCK-OUT
D	7/8" DIA. [22] FIELD CONTROL WIRING HOLE

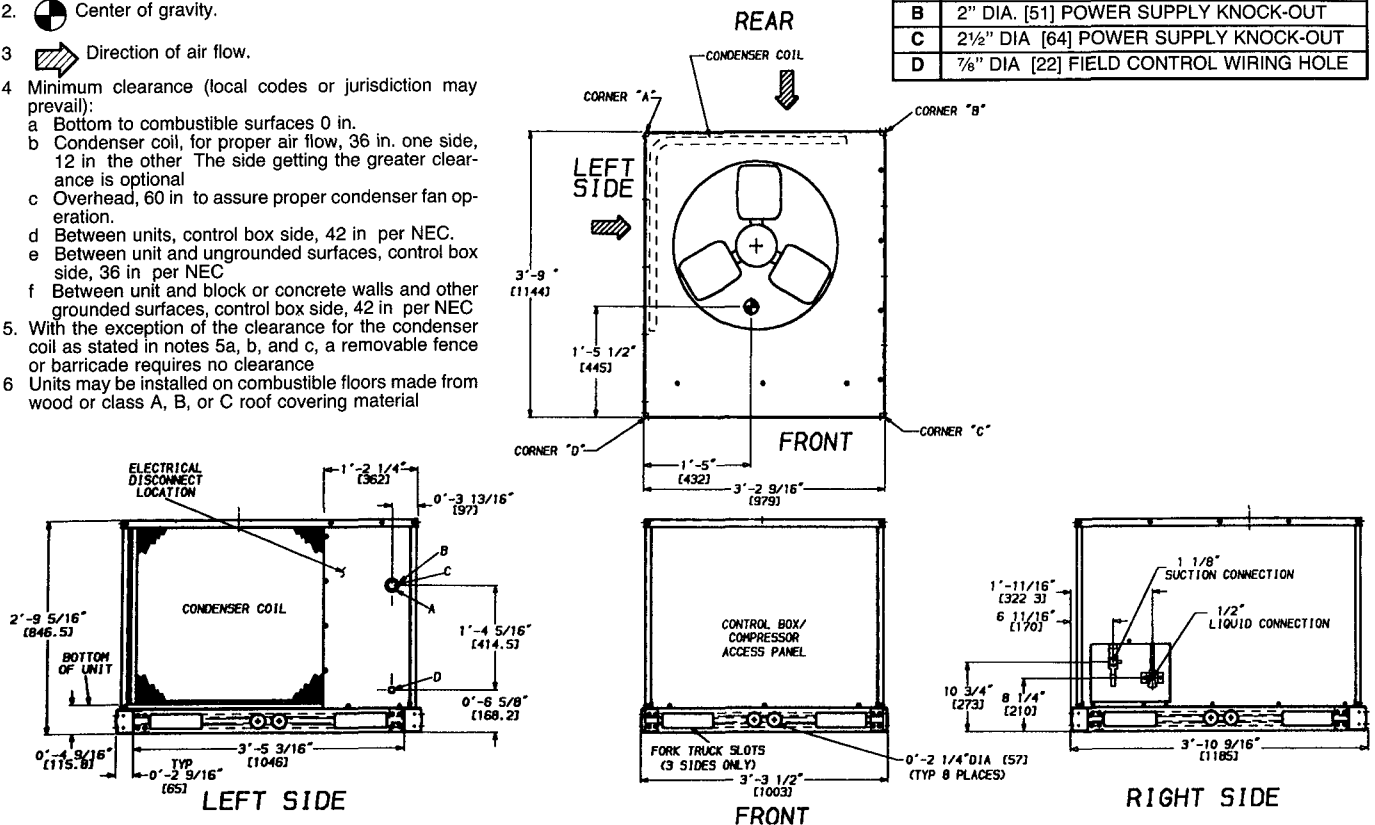
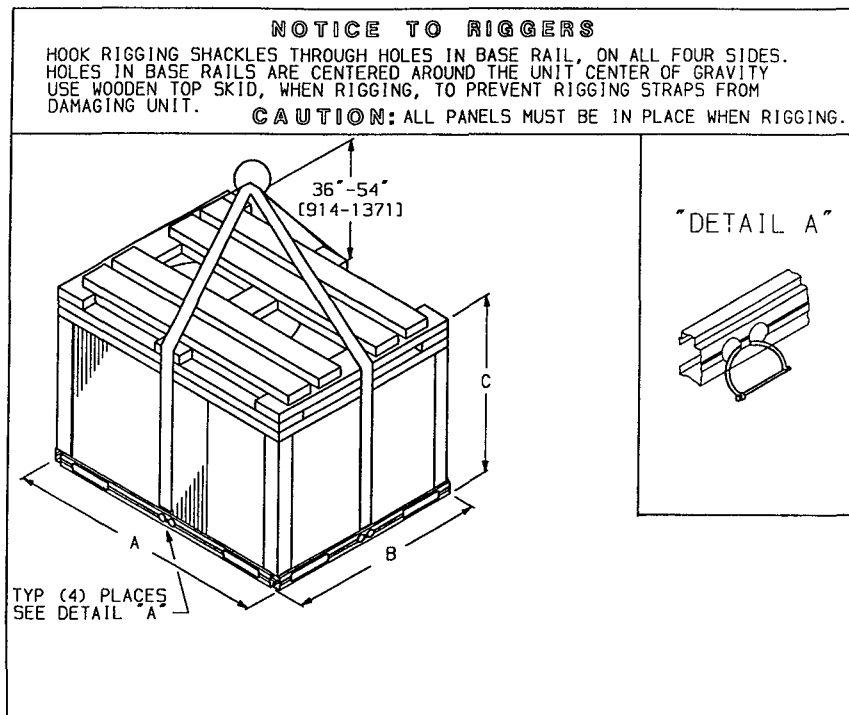

Fig. 1 - Dimensions (ft-in.)



UNIT	MAX WEIGHT		A		B		C	
	lb.	kg.	in.	mm	in.	mm	in.	mm
38AK007	390	177	46.7	1186	39.6	1006	35.5	904

Fig. 2 - Rigging Label

**FIELD POWER SUPPLY** — All units except 208/230-v units are factory wired for the voltage shown on the nameplate. If the 208/230-v unit is to be connected to a 208-v power supply, the transformer *must* be rewired by moving the black wire from the 230-v orange wire on the transformer and connecting it to the 200-v red wire from the transformer. The end of the orange wire must then be insulated.

Refer to unit label diagram for additional information. Pigtails are provided for field wire connections. Use factory-supplied splices or UL (Underwriters' Laboratories) approved copper/aluminum connector.

When installing units, provide a disconnect per NEC.

All field wiring must comply with NEC and local requirements.

Install field wiring as follows:

1. Install conduit through side panel openings.
2. Install power lines to connections as shown in Fig. 3. Wrap connections with electrical tape.

Voltage to compressor terminals during operation must be within voltage range indicated on unit nameplate (also see Table 4). On 3-phase units, voltages between phases must be balanced within 2% and the current within 10%.

Use the formula shown in Table 4, Note 2, to determine the % voltage imbalance. Operation on improper line voltage or excessive phase imbalance constitutes abuse and may cause damage to electrical components. Such operation would invalidate any applicable Carrier warranty.

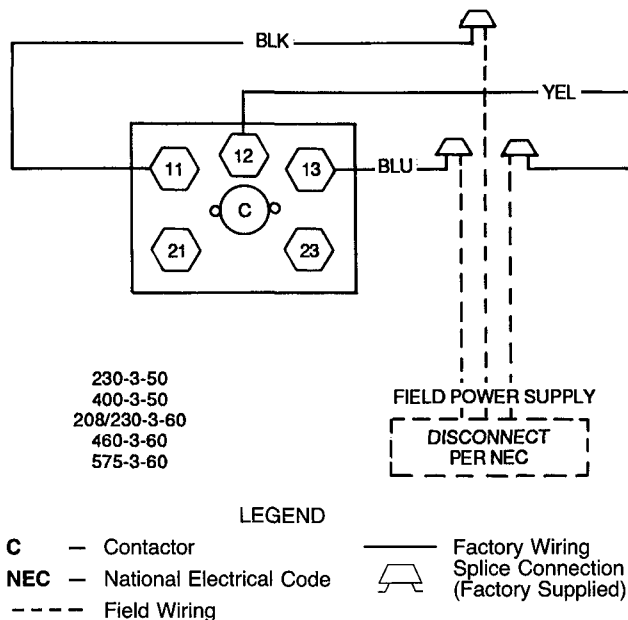

**Fig. 3 — Power Wiring Connections**

**Table 4 — Electrical Data**

UNIT	NOMINAL VOLTAGE (V-Ph-Hz)	VOLTAGE RANGE		COMPR		OFM	POWER SUPPLY	
		MIN	MAX	RLA	LRA	FLA	MCA	MOCP
38AK007	208/230-3-60	187	254	19.0	142	1.9	25.6	35.1
	460-3-60	414	508	9.5	72	1.0	12.9	17.6
	575-3-60	518	632	7.6	58	1.9	11.4	15.2
	220-3-50	198	242	19.0	142	1.9	25.6	35.1
	400-3-50	360	440	9.5	72	1.0	12.9	17.6

- LEGEND
- CSA** — Canadian Standards Association
  - FLA** — Full Load Amps
  - HACR** — Heating, Air Conditioning and Refrigeration
  - LRA** — Locked Rotor Amps
  - MCA** — Minimum Circuit Amps
  - MOCP** — Maximum Overcurrent Protection
  - NEC** — National Electrical Code
  - OFM** — Outdoor (Condenser) Fan Motor
  - RLA** — Rated Load Amps

Example: Supply voltage is 460-3-60.

AB = 452 v  
 BC = 464 v  
 AC = 455 v

$$\text{Average Voltage} = \frac{452 + 464 + 455}{3} = \frac{1371}{3} = 457$$

NOTE: The 575-v units are CSA only.

- (AB) 457 - 452 = 5 v
- (BC) 464 - 457 = 7 v
- (AC) 457 - 455 = 2 v

Maximum deviation is 7 v.

Determine % voltage imbalance

$$\% \text{ Voltage Imbalance} = 100 \times \frac{7}{457} = 1.53\%$$

This amount of phase imbalance is satisfactory as it is below the maximum allowable 2%.

**IMPORTANT:** If the supply voltage phase imbalance is more than 2%, contact your local electric utility company immediately.

**FIELD CONTROL WIRING** — Install a Carrier-approved accessory thermostat assembly according to installation instructions included with the accessory. Locate thermostat assembly on a solid wall in the conditioned space to sense average temperature in accordance with thermostat installation instructions.

Route thermostat cable or equivalent single leads of colored wire from subbase terminals to low-voltage connections on unit (shown in Fig. 4) as described in Steps 1 through 3 below.

**NOTE:** For wire runs up to 50 ft, use no. 18 AWG (American Wire Gage) insulated wire (35 C minimum). For 50 to 75 ft, use no. 16 AWG insulated wire (35 C minimum). For over 75 ft, use no. 14 AWG insulated wire (35 C minimum). All wire larger than no. 18 AWG cannot be directly connected to the thermostat and will require a junction box and splice at the thermostat.

1. Connect thermostat wires to screw terminals of low-voltage connection board.
2. Pass the control wires through the hole provided in the corner post.
3. Feed wire through the raceway built into the corner post to the 24-v barrier located on the left side of the control box. See Fig. 5. The raceway provides the UL required clearance between the high- and low-voltage wiring.

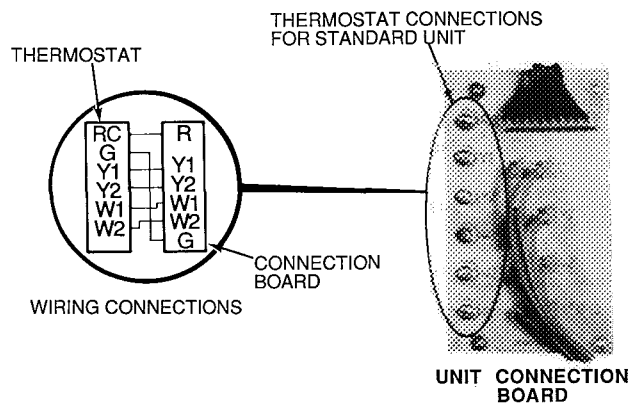

**Fig. 4 — Control Wiring Connections**

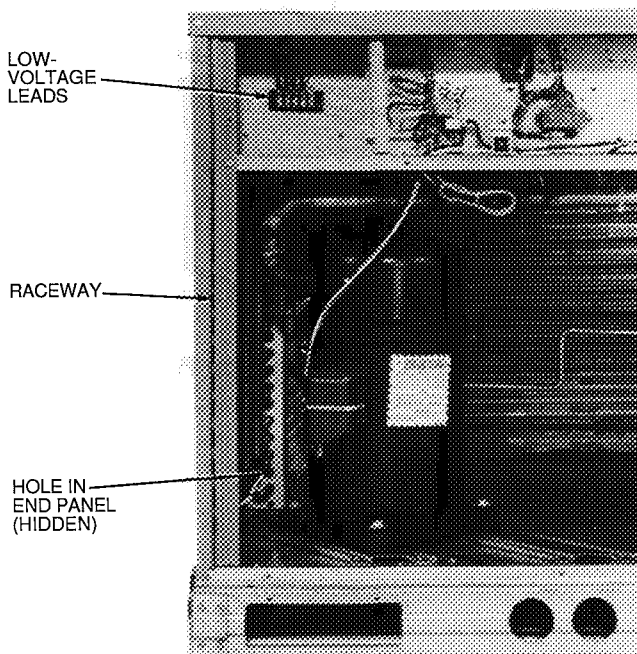

**Fig. 5 — Field Control Wiring Raceway**

## START-UP

### Preliminary Checks

1. Check that all internal wiring connections are tight and that all barriers, covers, and panels are in place.
2. Field electrical power source must agree with unit name-plate rating.
3. All service valves must be open.

**Leak Test** — Test entire refrigerant system by using soap bubbles and/or an electronic leak detector.

**Evacuate and Dehydrate** — Evacuate and dehydrate entire refrigerant system by use of the methods described in GTAC II, Module 4, System Dehydration.

**Refrigerant Charge** — Refer to GTAC II, Module 5, Charging Recovery, Recycling and Reclamation.

Unit panels must be in place when unit is operating during charging procedure.

Unit is shipped with holding charge only. Weigh in 7 lbs R-22 to start unit.

**NO CHARGE** — Use standard evacuating techniques. After evacuating system, weigh in the specified amount of refrigerant. (Refer to Table 1.)

**LOW CHARGE COOLING** — Use Cooling Charging Chart, Fig. 6. Vary refrigerant until the conditions of the chart are met. Note the charging chart is different from type normally used. Chart is based on charging the units to the correct subcooling for the various operating conditions. Accurate pressure gage and temperature sensing device are required. Connect the pressure gage to the service port on the liquid line service valve. Mount the temperature sensing device on the liquid line, close to the liquid line service valve and insulate it so that outdoor ambient temperature does not affect the reading. Indoor-air cfm must be within the normal operating range of the unit.

Operate unit and adjust charge to conform with charging chart, using liquid pressure and temperature to read chart.

**TO USE COOLING CHARGING CHART** — Initially charge with 7 lbs. R-22. Place pressure gage at liquid line service valve. Install thermocouple to liquid line near the liquid line service valve. Operate unit. Plot liquid pressure and temperature on chart and add or reduce charge to meet curve.

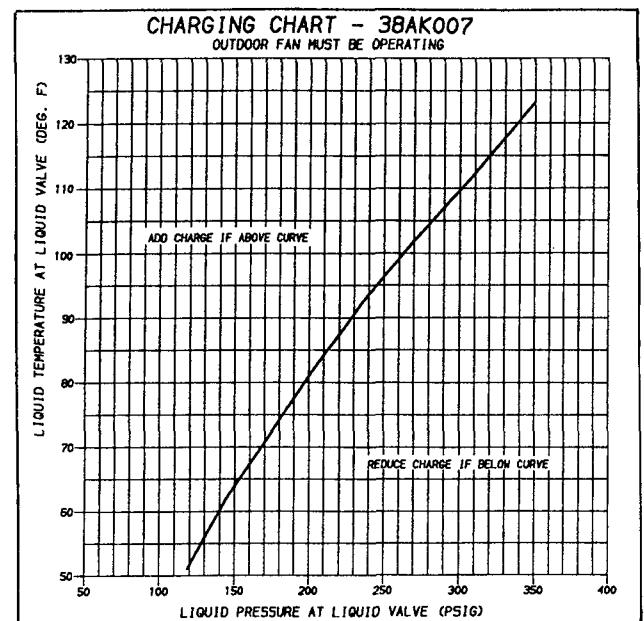

**Fig. 6 — Cooling Charging Chart — 38AK007**

**Unit Preparation** — Make sure that unit has been installed in accordance with installation instructions and applicable codes.

**Compressor Mounting** — Compressors are internally spring mounted. Do not loosen or remove compressor holddown bolts.

**Internal Wiring** — Check all electrical connections in unit control boxes; tighten as required.

**Time Guard II® Device** — Time Guard II Circuit provides for a delay of approximately 5 minutes before restarting compressor after shutdown from safety device action.

On start-up, the Time Guard timer causes a delay of approximately 15 seconds after thermostat closes.

**Refrigerant Service Ports** — Each unit system may have Schrader type service ports: one on the suction line, one on the liquid line, and one on the compressor discharge line. Be sure that caps on the ports are tight.

**Cooling** — Set space thermostat to OFF position. Set system selector switch at COOL position and fan switch at AUTO position. Adjust thermostat to a setting below room temperature. Compressor starts on closure of contactor.

Check cooling effects at a setting below room temperature. Check unit charge. Refer to Refrigerant Charge section on page 5.

Reset thermostat at a position above room temperature. Compressor will shut off.

**TO SHUT OFF UNIT** — Set system selector switch at OFF position. Resetting thermostat at a position above room temperature shuts unit off temporarily until space temperature exceeds thermostat setting. Units are equipped with Cycle-LOC™ protection device. Unit shuts down on any safety trip and remains off; an indicator light on thermostat comes on. Check reason for safety trip.

Compressor restart is accomplished by manual reset at the thermostat by turning the selector switch to OFF position and then to ON position.

**Sequence of Operation** — At start-up, the thermostat calls for cooling, and with all safety devices satisfied, the compressor contactor and fan contactor will energize, causing the compressor and outdoor-fan motor to operate. Contacts on TB1 terminals 1 and 2 are also energized, allowing the field supplied and installed indoor-fan contactor to function. A field supplied and installed liquid line valve (connect to TB1 terminals 3 and 4) will also open, allowing the system to function in cooling. As cooling demand is satisfied, the thermostat contacts break, deenergizing the contactor causing the system to shut off. The liquid line shutoff valve closes minimizing the potential for refrigerant migration at this time. The compressor does not restart until the thermostat again calls for cooling. If a demand for cooling occurs within 5 minutes after the thermostat is satisfied, the system will not restart due to the feature of Time Guard®II. After the 5 minute time period, the system will restart as normal upon thermostat demand. The system is protected with Cycle-Loc device so that the compressor will not start if a high-pressure or low-pressure fault occurs. Merely turn down the thermostat to eliminate the cooling demand to reset the Cycle-Loc device. This should be done only once, and if system shuts down due to the same fault, determine the problem before attempting to reset the Cycle-Loc device. The 38AK007 unit does not require a crankcase heater.

## SERVICE

### ⚠ CAUTION

When servicing unit, shut off all electrical power to unit to avoid shock hazard or injury from rotating parts.

**Cleaning** — Inspect unit interior at the beginning of each cooling season and as operating conditions require.

**CONDENSER COIL** — Inspect coil monthly. Clean condenser coil annually and as required by location or outdoor-air conditions.

Clean coil as follows:

1. Turn off unit power.
2. Remove top panel screws on condensing unit.
3. Remove condenser coil corner post. See Fig. 7. To hold top panel open, place coil corner post between top panel and side panel. See Fig. 8.

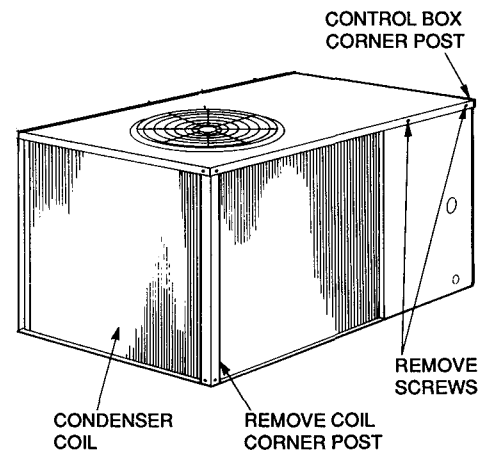

Fig. 7 — Cleaning Condenser Coil

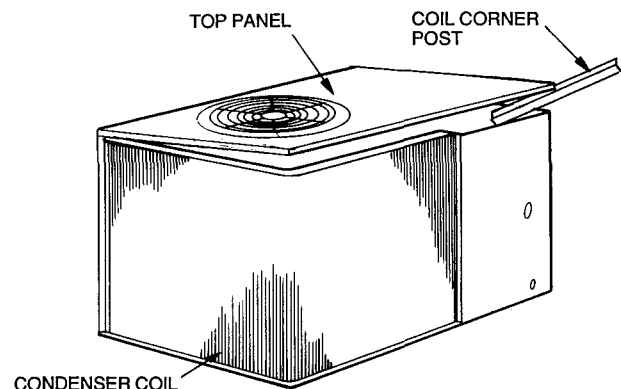
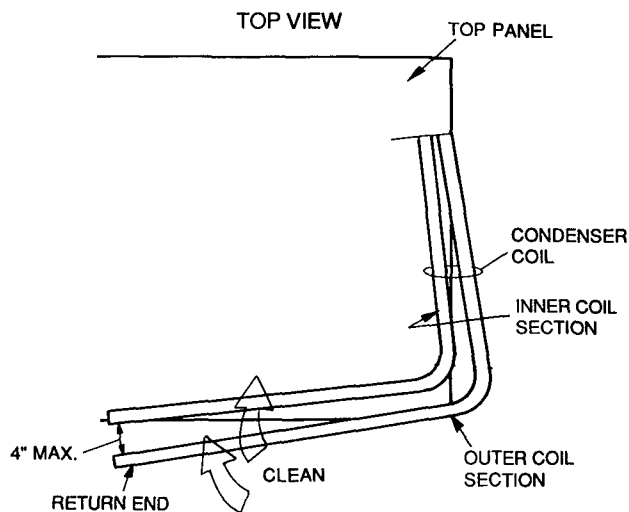

Fig. 8 — Propping Up Top Panel



**Fig. 9 – Separating Coil Sections**

4. Remove device holding coil sections together at return end of condenser coil. Carefully separate the outer coil section 3 to 4 in. from the inner coil section. See Fig. 9.
5. Use a water hose or other suitable equipment to flush down between the 2 coil sections to remove dirt and debris. Clean the outer surfaces with a stiff brush in the normal manner.
6. Reposition the outer coil section, and remove the coil corner post from between the top panel and side panel. Secure the sections together. Install the coil corner post and replace all screws.

### Lubrication

**COMPRESSORS** — Each compressor is charged with correct amount of oil at the factory.

**FAN MOTOR BEARINGS** — Fan motor bearings are of the permanently lubricated type. No further lubrication is required.

### Condenser-Fan Adjustment (Fig. 10)

1. Shut off unit power supply.
2. Remove condenser-fan assembly (grille, motor, motor cover, and fan).
3. Loosen fan hub setscrews.
4. Adjust fan height as shown in Fig. 10.
5. Tighten setscrews.
6. Replace condenser-fan assembly.

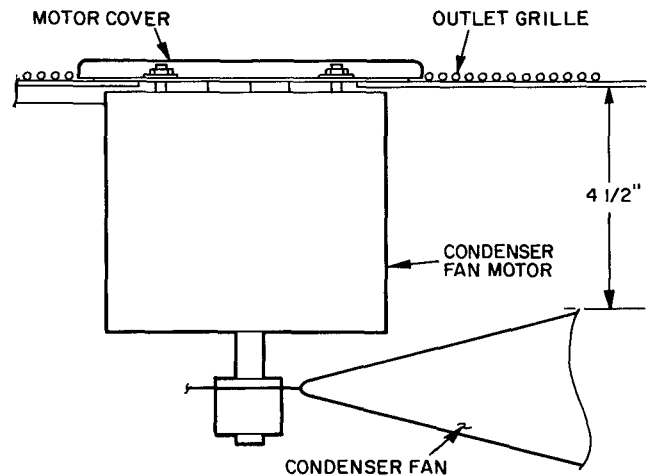

**Fig. 10 – Condenser-Fan Adjustment**

## TROUBLESHOOTING GUIDE

### COMPRESSOR DOES NOT RUN

#### Contactors Open

Power off — *restore power.*  
Fuses blown — *replace with correct fuses after finding cause and correcting.*  
Transformer dead — *replace transformer if primary windings are receiving power.*  
Thermostat circuit open — *check thermostat setting.*  
Low-pressure switch open — *check for refrigerant undercharge or obstruction of indoor airflow.*  
High-pressure switch open — *check for refrigerant overcharge or obstruction of outdoor airflow.*  
Connections loose — *tighten all connections.*  
Compressor motor thermostat open — *check for excessive motor temperature.*

#### Contactors Closed

Compressor leads loose — *check connections.*  
Single phasing — *replace blown fuse.*

### COMPRESSOR CYCLES ON HIGH-PRESSURE SWITCH

#### Condenser Fan On

High-pressure switch faulty — *replace switch.*  
Airflow restricted — *remove obstruction.*  
Air recirculating — *clear airflow area.*  
Noncondensables in system — *purge and recharge as required.*  
Refrigerant overcharge — *purge as required.*  
Refrigerant system restrictions — *check or replace filter drier, expansion valve, etc.*

#### Condenser Fan Off

Fan slips on shaft — *tighten fan hub setscrews.*  
Motor not running — *check power and capacitor.*  
Motor bearings stuck — *replace bearings.*  
Motor overload open — *check overload rating. Check for fan blade obstruction.*  
Motor burned out — *replace motor.*

### COMPRESSOR CYCLES ON LOW-PRESSURE SWITCH

#### Evaporator Air Fan Running

Filter drier plugged — *replace filter drier.*  
Expansion valve power head defective — *replace power head.*  
Low refrigerant charge — *add charge. Check low-pressure switch setting.*

#### Airflow Restricted

Evaporator coil iced up — *check refrigerant charge.*  
Evaporator coil dirty — *clean coil fins.*  
Indoor air filter dirty — *clean or replace filters.*  
Indoor air dampers closed — *check damper operation and position.*

#### Evaporator Air Fan Stopped

Electrical connections loose — *tighten all connections.*  
Fan relay defective — *replace relay.*  
Motor overload open — *check power supply.*  
Motor defective — *replace motor.*  
Fan belt broken or slipping — *replace or tighten belt.*

### COMPRESSOR RUNS BUT COOLING INSUFFICIENT

#### Suction Pressure Low

Refrigerant charge low — *check charge.*  
Head pressure low — *check refrigerant charge.*  
Indoor-air filters dirty — *clean or replace filters.*  
Expansion valve power head defective — *replace power head.*  
Evaporator coil partially iced — *check low-pressure setting.*  
Evaporator airflow restricted — *remove obstruction.*

#### Suction Pressure High

Heat load excessive — *check for open doors or windows.*



## Free Manuals Download Website

<http://myh66.com>

<http://usermanuals.us>

<http://www.somanuals.com>

<http://www.4manuals.cc>

<http://www.manual-lib.com>

<http://www.404manual.com>

<http://www.luxmanual.com>

<http://aubethermostatmanual.com>

Golf course search by state

<http://golfingnear.com>

Email search by domain

<http://emailbydomain.com>

Auto manuals search

<http://auto.somanuals.com>

TV manuals search

<http://tv.somanuals.com>