



RED PLANET
SERIES

RP-100 TELESCOPE
Instruction Manual



CARSON®

Carson Optical
35 Gilpin Avenue
Hauppauge, NY 11788-4723
Phone: 631-963-5000
Fax: 631-427-6749

For information, call toll-free: 1-800-967-8427

info@carsonoptical.com / sales@carsonoptical.com / www.carsonoptical.com

Table of Contents:

	Introduction
3	Box Contents
4-8	Figures 1-8/Figure Key
9-11	Telescope Assembly <ul style="list-style-type: none">• Setting up Your Tripod• Attaching the U Mount• Attaching the Telescope Tube to the Mount• Attaching the Finder Scope• Attaching the Eyepieces• Aligning the Finder Scope
11	Calculating Power
11	Understanding Celestial Movement
12-13	Using the Telescope
13-16	Care and Maintenance of Your Telescope <ul style="list-style-type: none">• Cleaning• Collimation of Optics• Adjusting the Diagonal Holder• Adjusting the Primary Mirror• Night Time Star Collimation Testing
17	Specifications
17	Warnings
17	Customer Service
18	Warranty Information

Congratulations on your purchase of a Carson RP-100 **Red Planet Series™** telescope. This telescope features an easy-to-use design and high performance optics that are perfect for beginning astronomers looking to explore the wonders of outer space and the world around them. Please read this manual carefully to ensure that you assemble and use your telescope correctly. When used properly, your **Red Planet™** telescope should provide years of exciting observations of the universe and the world around you. Please note that this Newtonian Reflector telescope was designed for both astronomical and terrestrial viewing.

IMPORTANT: DO NOT USE YOUR RED PLANET™ TELESCOPE TO LOOK AT OR NEAR THE SUN! DOING SO WILL CAUSE INSTANT AND PERMANENT EYE DAMAGE.

Each box contains the following:

- Complete Optical Tube Assembly
- U Mount
- Heavy-Duty Aluminum Tripod
- 8mm Huygenian Erecting Eyepiece (1.25"O.D.)
- 20mm Huygenian Erecting Eyepiece (1.25"O.D.)
- 10x30mm Erecting Finder Scope

Please unpack your telescope carefully and make sure that all accessories are included in the box.

Fig.1



Fig.3

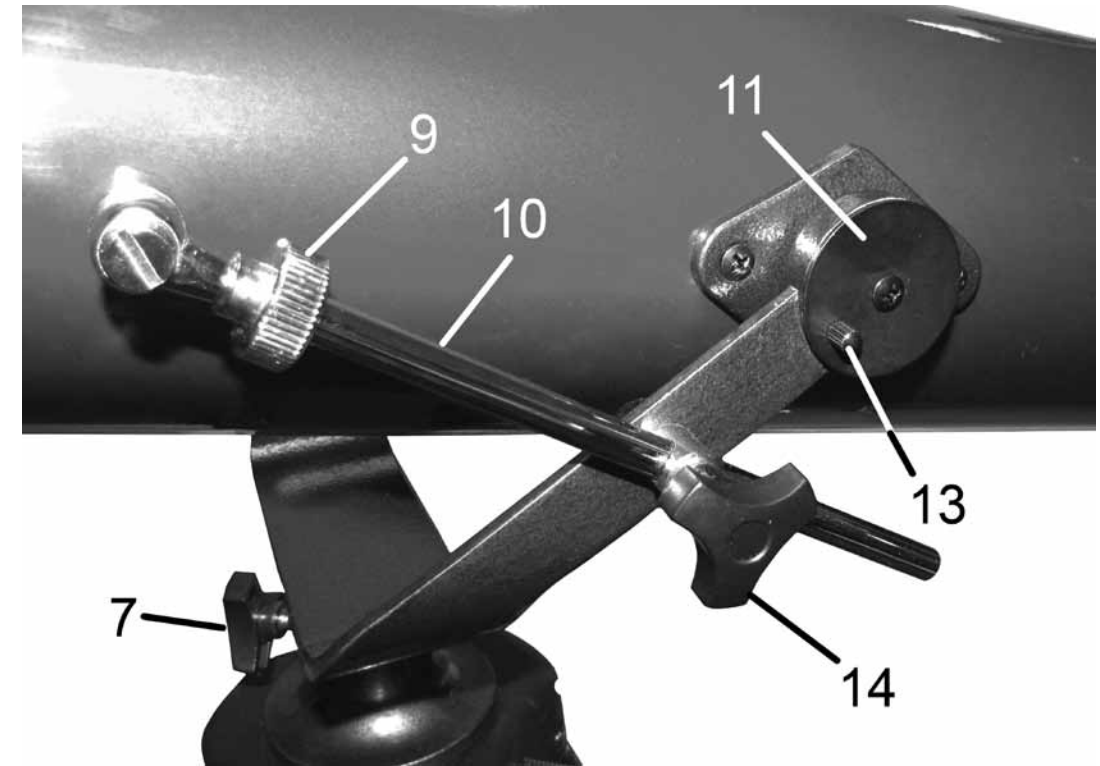

Fig.2

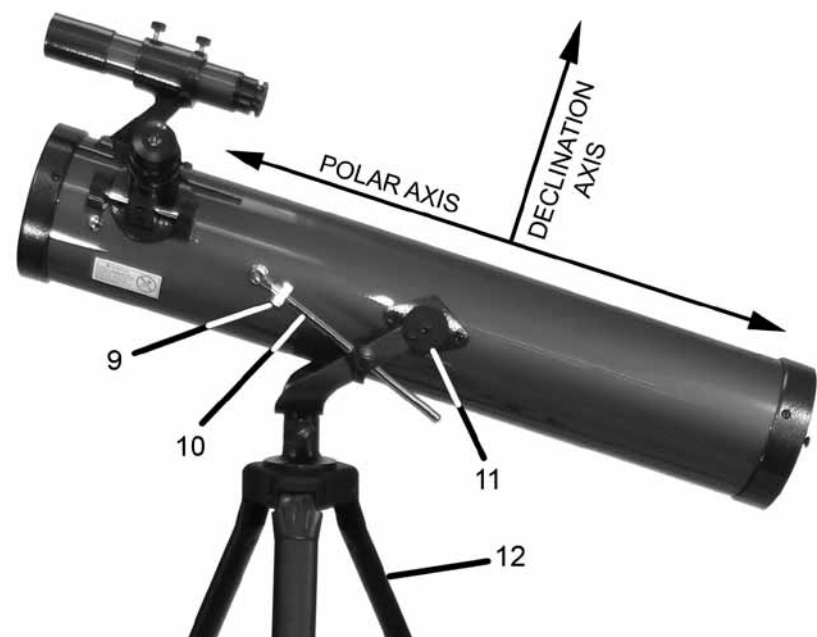

Fig.4

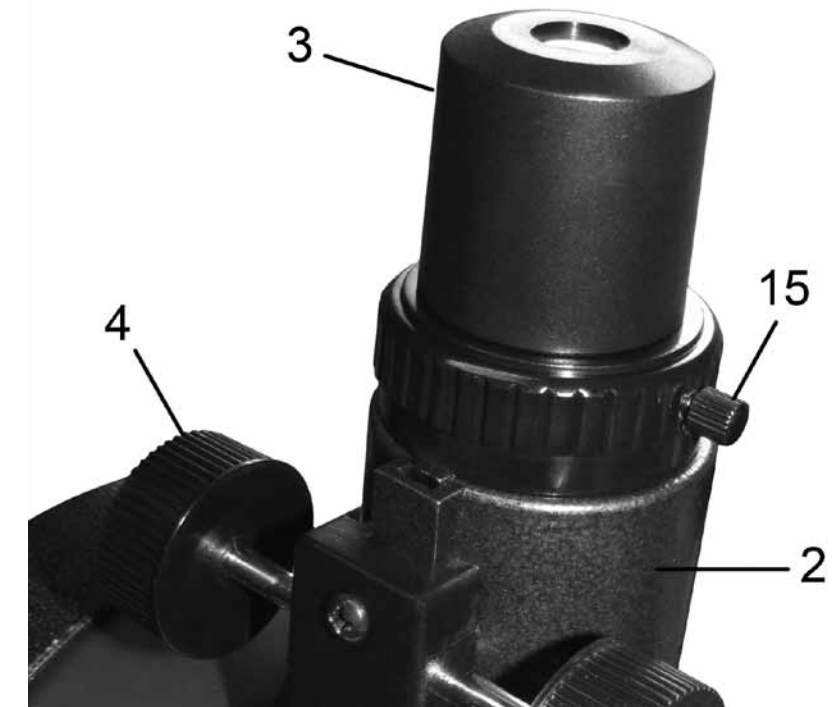

Fig.5

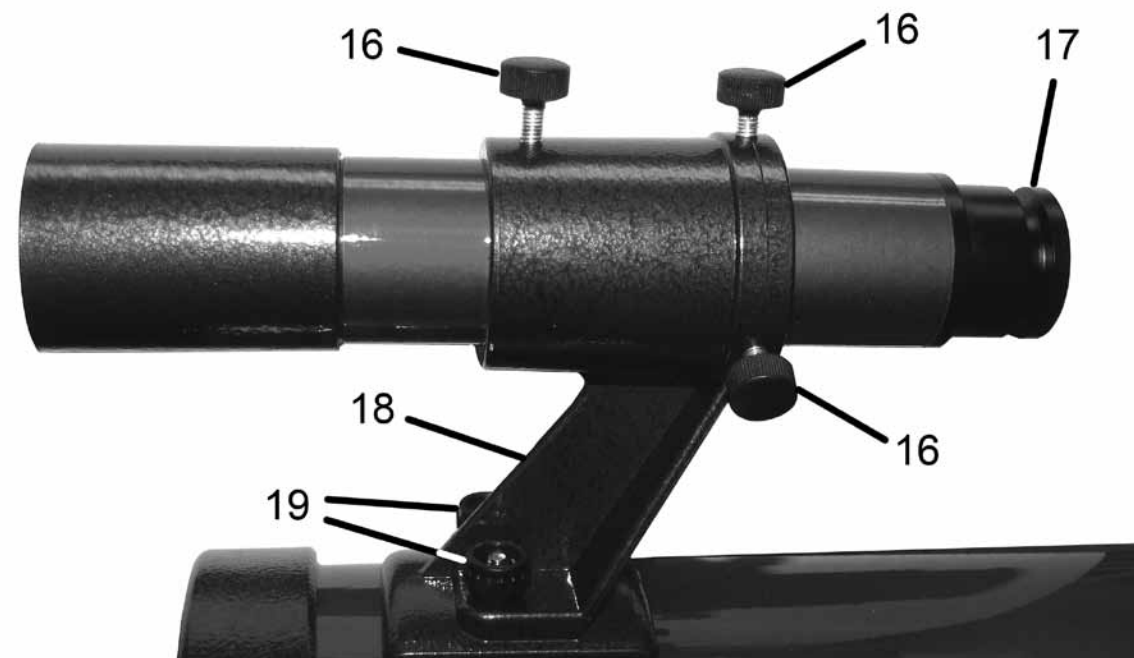

Fig.6

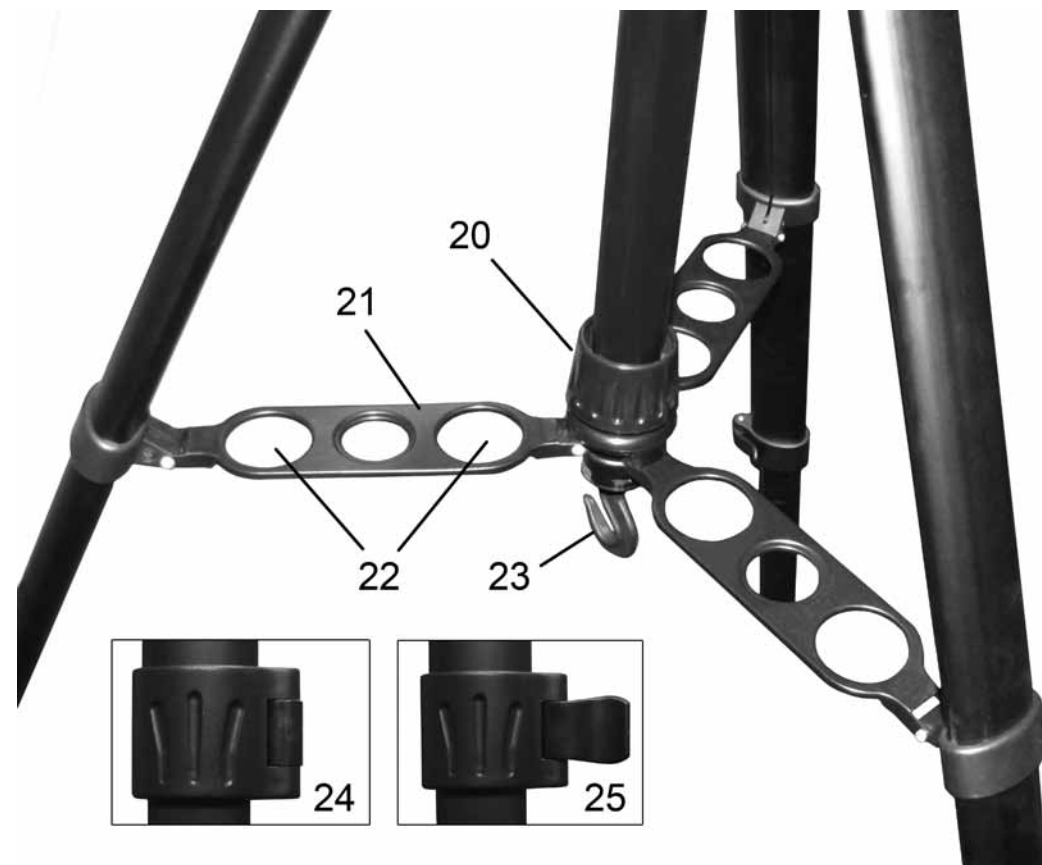
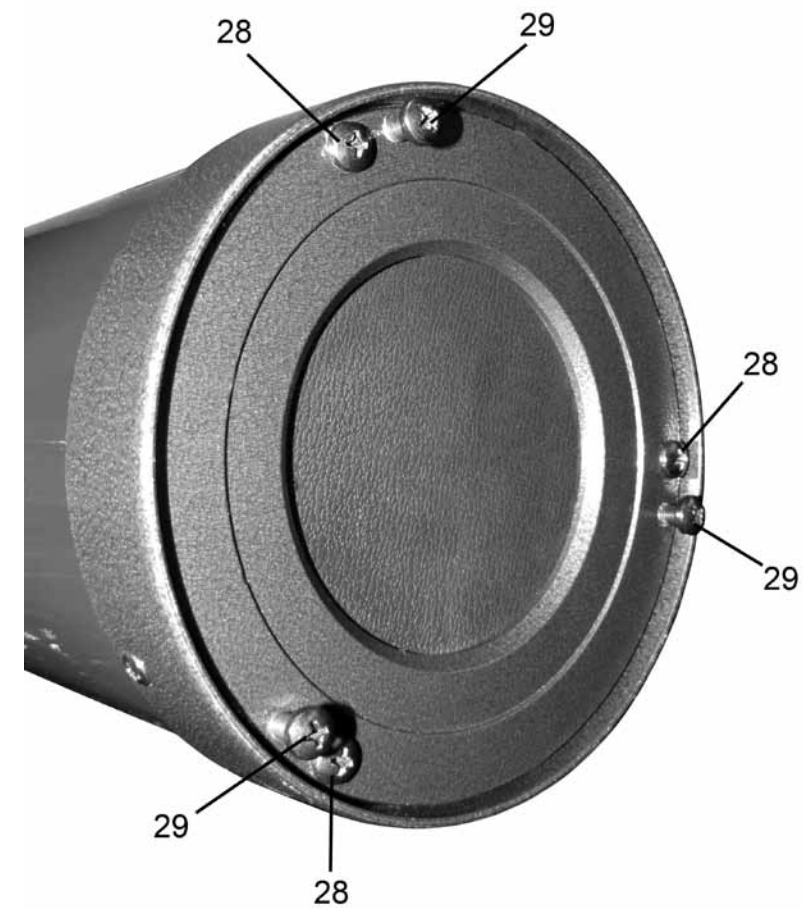

Fig.7



Fig.8



Key to Figures 1-8:

1. 10x30mm Finder Scope
2. Focuser
3. Eyepiece
4. Focus Knobs
5. Optical Tube Assembly
6. U Mount
7. Horizontal Lock Knob
8. U Mount Locking Screw
9. Altitude Rod Fine Adjustment Control
10. Altitude Rod
11. Locking Plates
12. Tripod Legs
13. Locking Plate Thumbscrews
14. Altitude Rod Coarse Adjustment Control
15. Focuser Thumbscrew
16. Finder Scope Bracket Thumbscrew
17. Finder Scope Focus Knob
18. Finder Scope Bracket
19. Finder Scope Bracket Mounting Bolts
20. Tripod Tightening Ring
21. Tripod Brace
22. Eyepiece Holder Slots
23. Tripod Hook
24. Tripod Leg Lock Closed
25. Tripod Leg Lock Open
26. Diagonal Mirror Tilt Screws
27. Diagonal Mirror Holder
28. Primary Mirror Locking Screws
29. Primary Mirror Tilt Screws

Assembly of your Red Planet Telescope:

Setting Up Your Tripod:

The aluminum tripod comes preassembled and ready-to-use. Remove the tripod from the box and pull apart the legs. Gently push down the tripod braces (Fig. 6-21) until they are in the lowest position. Turn the tightening ring (Fig. 6-20) (located at the center of the tripod brace) clockwise to lock the tripod in the open position. You can then extend the legs to the desired height by pulling open the tab on each leg lock (Fig. 6-25), sliding the leg down the desired amount and then pushing the leg lock back against the leg into the locked position (Fig. 6-24). Repeat the process with each leg trying to keep the tripod as level as possible with the ground. You will notice there are holes in the tripod leg braces (Fig. 6-22). These are designed to hold eyepieces when not in use.

Attaching the U Mount:

Remove the U mount (Fig. 1-6) from the box. Place the bottom of the mount into the hole in the top of the tripod head and secure with the mount locking screw (Fig. 1-8). Please be careful to make sure that the mount is securely attached to the tripod.

Attaching the Telescope Tube to the Mount:

Carefully remove the optical tube assembly (Fig. 1-5) from the box. Gently place the optical tube between the forks of the U mount with the focuser (Fig. 1-2) towards the front. Slide the knobs located on the sides of the optical tube assembly into the corresponding openings at the top of the U mount. Twist the locking plates (Fig. 3-11) on the sides of the telescope until the thumbscrew (Fig. 3-13) is aligned with the holes on the forks of the mount. Tighten the thumbscrews to secure the telescope to the mount. Slide the altitude rod (Fig. 3-10) into the hole in the altitude coarse adjustment control (Fig. 3-14). Align the end of the altitude rod with the corresponding threaded hole on the telescope and secure using the included screw. Be careful not to over-tighten.

Attaching the Finder Scope:

There are two finder scope bracket mounting bolts (Fig. 5-19) located at the front end of the optical tube. Remove the nuts and set aside. Place the finder scope bracket (Fig. 5-18) onto the mounting bolts, replace the nuts and tighten down securely to the optical tube. Make sure the bracket is oriented as shown in Fig. 5. Slide the finder scope (Fig. 1-1) into the bracket facing forward.

Attaching the Eyepieces:

Insert the Huygenian 20mm eyepiece (Fig. 4-3) into the focuser (Fig. 4-2) and tighten down using the focuser locking screw (Fig. 4-15).

You have now completed the assembly of your Red Planet™ telescope. We will now need to make the necessary adjustments in order to use your telescope properly.

Aligning the Finder Scope:

The low power and wide field of view provided by the 10x30mm finder scope (Fig. 1-1) provides a quick and easy way to sight an object prior to looking through the high-power telescope. The finder scope must first be properly aligned with the telescope in order to work properly. This alignment is best performed during the daylight. Follow the steps below to align your finder scope properly:

- Place the Huygenian 20mm eyepiece (Fig. 1-3) into the focuser (Fig. 1-2) of the telescope.
- Loosen the horizontal lock knob (Fig. 1-7) and the altitude rod coarse adjustment lock knob (Fig. 3-14).
- Point the main telescope at a specific land object 200 yards or more away and center that object in the telescope field of view. Lock down the horizontal lock knob (Fig. 1-7) and the altitude rod coarse adjustment lock knob (Fig. 3-14) being careful to keep the object centered.
- Now look through the finder scope and loosen or tighten the finder scope bracket thumb screws (Fig. 5-16) until the crosshairs are centered on the same object. Focus by turning the finder scope focus knob (Fig. 5-17) until the image in the finder scope is sharp and clear.
- Check the alignment at nighttime by repeating this process with a bright star or the moon. Make any necessary adjustments.

Now that your finder scope is properly aligned, any object centered in your finder scope should also be centered in your telescope.

Calculating Power:

The magnification of a telescope depends on both the focal length of your telescope as well as the eyepiece you use. There is a simple formula you can use to determine the magnification you are using at any given time. Simply divide the focal length of the telescope by the focal length of the eyepiece. For example, if you are using the 20mm eyepiece with your TP-100 telescope the power would be:

$$\text{Power} = 700\text{mm} / 20\text{mm} = 35\text{x}$$

Using an eyepiece with a smaller focal length will increase the magnification of your telescope. It is always best to start at the lowest magnification configuration. The wider field of view makes it easier to spot far away objects. Once an object is centered in your field of view you can switch to the higher power configurations.

Understanding Celestial Movement:

In order to get the most enjoyment out of your telescope it is necessary to know the basics of how celestial objects move across the sky. Due to the rotation of the earth, celestial objects appear to move from East to West across the sky, much like the Sun. You will notice this movement as an object in your telescope field of view will slowly move across the field and out of view. Continuous adjustment is needed to keep an object in the field of view.

Using the Telescope:

Once you have properly assembled and aligned your telescope you are finally ready to start using it.

- To locate an object using the telescope, first loosen the horizontal lock knob (Fig. 1-7) and the altitude rod coarse adjustment lock knob (Fig. 3-14) allowing the telescope to rotate along both axes. Look through the finder scope (Fig. 1-1) to sight the object you are looking for and center it in the finder scope cross-hairs. You may need to focus the finder scope by turning the finder scope focus knob (Fig. 5-17). Then re-tighten the horizontal lock knob and the altitude rod coarse adjustment lock knob.
- Coarse altitude adjustments can be made by loosening the altitude rod coarse adjustment lock knob (Fig. 3-14) and moving the telescope by hand. Finer altitude adjustments can be made by turning the altitude rod fine adjustment control (Fig. 3-9).
- It is best to use the lowest power eyepiece (the Huygenian 20mm eyepiece) at first. This allows for a wider field of view making it easier to locate objects. Once the object is centered in the field of view you can switch the eyepiece to higher magnifications.
- Once the object is centered in the field of view, turn the focus knobs (Fig. 1-4) on the eyepiece focuser (Fig. 1-2) until the image is clear and sharp.
- You will notice that the view through the finder scope and telescope are normal, unlike other telescopes that have inverted images. This normal view allows you to use this telescope for both terrestrial and astronomical viewing.
- It is best to start by viewing terrestrial objects during the day. This is a good way to practice observing with your telescope. At night it is best to start by looking at the moon or other easy to find celestial objects. As you become more experienced using your telescope you can begin to try locating harder to find objects.
- If you are viewing celestial objects, you will notice that the object will slowly move across the field of view (caused by the rotation of the Earth). You will need to slowly move the telescope vertically and/or horizontally to keep the object centered.

There are many conditions that may affect your ability to focus or observe celestial objects clearly.

- Brightly lit areas (light pollution) will make it difficult to see faint objects in the sky. It will also make it difficult for your eyes to adjust to the dark. You should try and find a dark area and allow your eyes

to adjust to the dark before making observations. Using a red filtered flashlight to view charts and your telescope components is recommended to preserve your night sight. The best viewing conditions are when the sky is inky black.

- Hazy skies, pollution, clouds and moisture can all affect the clarity of your viewing image.
- Avoid touching the eyepiece or optical tube while looking through the telescope. The vibrations caused by this contact will cause the object you are looking at to move. You should also make sure that the surface you place your telescope on does not vibrate or move as this will also cause your viewing object to move.
- You should avoid setting up your telescope inside a room looking through an open window. The difference in air temperatures may result in a blurry image.
- Viewing through a closed window might also result in a distorted image due to the varying densities of window glass.
- Avoid viewing objects that are low on the horizon. Objects that are higher up in the sky will appear much sharper.
- Sudden changes in temperature may cause condensation to appear on the optical components of the telescope. It is best to set up your telescope ahead of time and then wait while the telescope adjusts to the new temperature before using it.

Care and Maintenance of Your Telescope:

Cleaning:

- Always replace dust covers and lens caps when not in use. This will minimize the amount of dust and debris that gets into your telescope.
- Cleaning should be performed only if absolutely necessary. If dust has built up on the optics use a soft camel's hair brush or pressurized air to gently remove it.
- If dew collects on the optics of your telescope or moisture condenses inside the optics, remove all accessories and place the telescope in a dry, dust free environment and point the telescope downward. This should help eliminate the moisture.
- Avoid touching the surface of the mirror.
- Do not attempt to take apart your telescope to clean it.

Fig.9

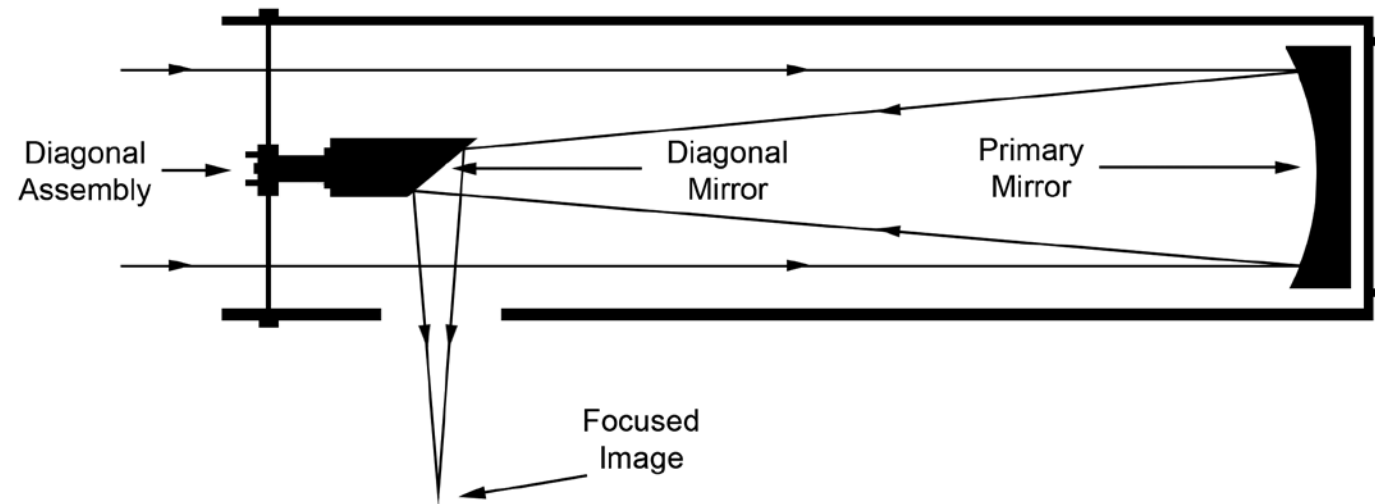

Collimation of the Optics:

The internal optics of the telescope have already been “collimated” or “aligned” at the factory. However, rough handling of the telescope may knock the optics out of collimation, resulting in poor optical performance. Please refer to Fig. 9 to better understand the internal layout of your telescope. To determine if your telescope needs collimation perform the following steps:

- Remove the eyepiece (Fig. 1-3) from the focuser (Fig. 1-2) and turn the focusing knob (Fig. 1-4) until the tube is at its innermost position.
- Point the telescope at a plain background and then peer through the empty focuser. You should see a series of concentric circles (See Fig. 10). The outer most circle being a reflection of the primary mirror (with three mirror clips). The inner circle is the diagonal mirror, which should be precisely centered inside the primary mirror. You should see the reflection of your eye in the diagonal mirror.

Adjusting the Diagonal Holder:

If the telescope is properly collimated you should see the primary mirror (See Fig. 10) and three clips in their entirety. If the primary mirror is not centered properly (See Fig. 11) you will need to adjust the diagonal mirror (See Fig. 9) to correct this. Loosen the diagonal mirror tilt screws (Fig. 7-26) so that you can move the diagonal holder (Fig. 7-27) with your hand.

Tilt the diagonal holder until the entire primary mirror is visible and carefully retighten the screws to lock it into place. If necessary, turn the three screws slightly to make fine adjustments.

Fig.10

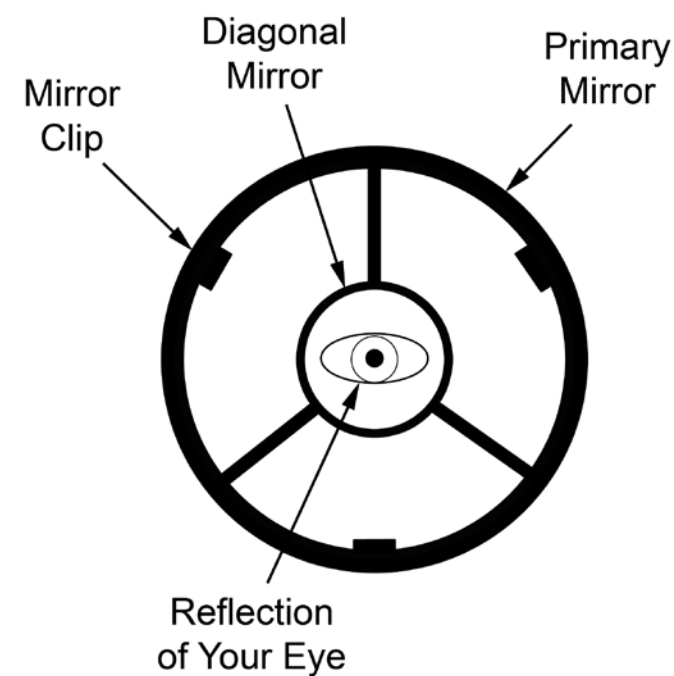
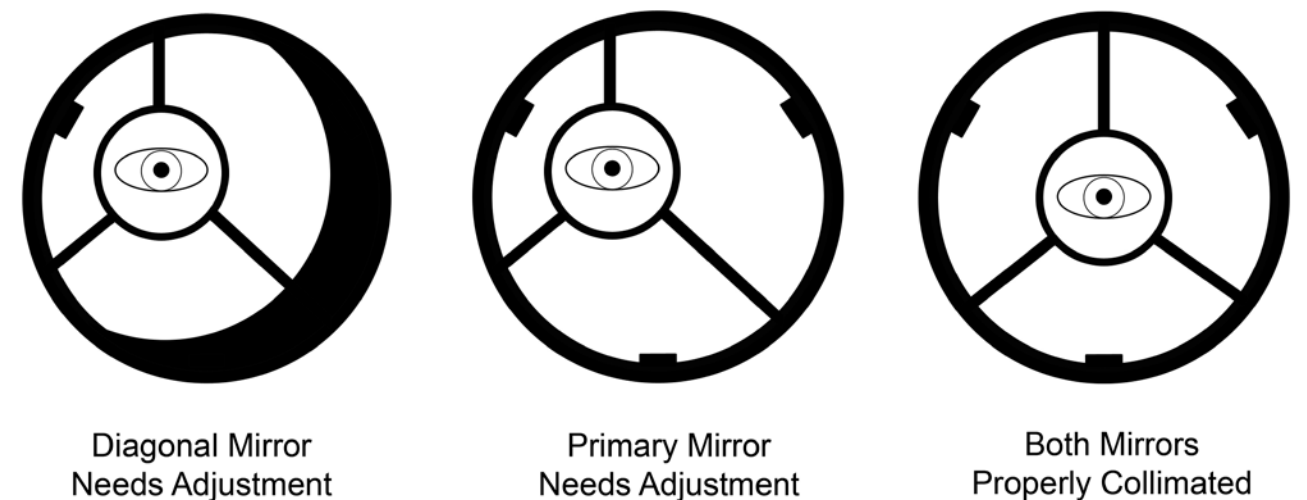

Fig.11



Adjusting the Primary Mirror:

If the telescope is properly collimated you should see the diagonal mirror (See Fig. 10) at the exact center of the primary mirror. If the diagonal mirror appears off-center (See Fig. 11) you will need to adjust the primary mirror (See Fig.9) located on the outside lower-end of the main tube.

To do this you will first need to loosen the primary mirror locking screws (Fig. 8-28). These are the screws that are flush against the surface of the telescope. Then alternately loosen and tighten the primary mirror tilt screws (Fig. 8-29) until the diagonal mirror is centered inside the primary mirror. The primary mirror tilt screws are easily identified because they stick out from the surface of the telescope. Once the adjustment is complete, re-tighten the primary mirror locking screws.

Night Time Star Collimation Testing:

- To test the accuracy of your collimation, equip your telescope with the 20mm eyepiece and focus on a moderately bright star.
- With the star centered in the field of view, slowly turn the focus knob (Fig. 1-4) until the star is out of focus.
- If properly collimated, you should see a series of concentric circles around a black center dot (Fig. 12-C).
- If the circles are not concentric and the black dot is not centered (Fig. 12A) you will need to make adjustments to the primary mirror. Loosen the primary mirror locking screws (Fig. 8-28) and use the horizontal and altitude adjustments to move the circles to the edge of the telescope field of view (Fig. 12-B). Then turn the primary mirror tilt screws (Fig. 8-29) until the black dot moves to the center of the image with the concentric circles radiating from it (Fig. 12-C). Once centered, tighten down the locking screws.

Fig.12

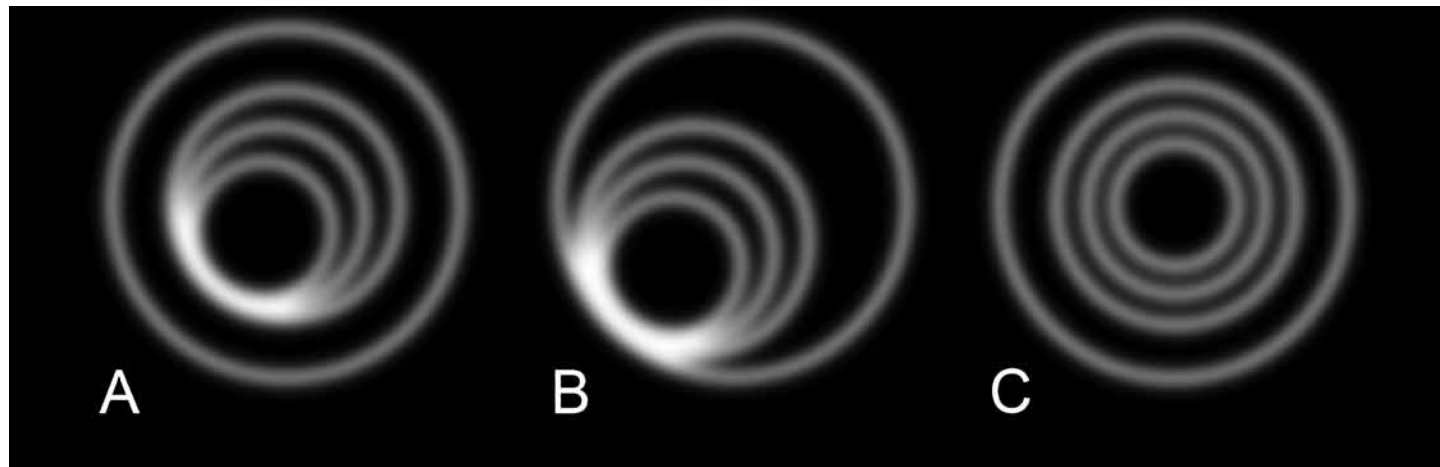

Specifications:

Optical Design:	Newtonian Reflector
Aperture:	76mm (2.99")
Focal Length:	700mm (27.56")
Focal Ratio:	9.21
Finder Scope:	10x30mm
Eyepiece 1:	Huygenian 20mm Erecting
Magnification 1:	35x
Eyepiece 2:	Huygenian 8mm Erecting
Magnification 2:	87.5x
Mount:	U Mount
Weight:	8 lbs.

Warnings:

- Never use this telescope (or its viewfinder) to look directly at or near the sun. Viewing the sun can cause instant and irreversible eye damage.
- Always supervise children when using this telescope.
- Do not leave telescope unattended at any time. Untrained adults or children may not be familiar with the correcting operating procedure.
- Do not point the telescope at the sun even when you are not looking through it. This will cause internal damage to the telescope.
- Handle this telescope with care. Rough handling might knock the internal optical components out of alignment.

Customer Service:

We will be happy to help you with any problems you may experience while using your telescope. Please call our toll-free customer service line at 1-800-967-8427.

Warranty Information:

This Carson product is warranted to be free from defects in material and workmanship for a period of one year from date of purchase. During this period Carson will, at its option and without charge, either repair any part or assembly of parts found to be defective in material or workmanship, or replace this Carson product with a Carson product of comparable value and condition, subject to the limitations and exclusions noted herein.

This warranty extends to the original purchaser only and is not assignable or transferable. It shall not apply to any product that has been subject to misuse, abuse, negligence or accident, or to any defects or damage directly or indirectly caused by the use of unauthorized replacement parts and/or service performed by unauthorized personnel.

This warranty gives you specific legal rights, and you may also have other rights which could vary from state to state. Some states do not allow limitations on the life of an implied warranty and/or do not allow excluding or limiting incidental or consequential damages. If so, the above limitations or exclusions may not apply to you.

Warranty Procedure:

Provide proof of purchase. A receipt or other dated proof of purchase must be included with merchandise being returned for a warranty claim to be processed.

Call or write for authorization. Before returning any product for a warranty claim, a Return Authorization (RA) number must be obtained. No merchandise will be accepted without an RA, and failure to obtain an RA will prevent or delay processing of the warranty claim. To obtain an RA call 631-963-5000, or write to Carson Warranty Service, 35 Gilpin Ave, Hauppauge NY 11788 with a description of the problem. Include your name, address and telephone number.

Package the return carefully. Shippers will not reimburse for damages due to insufficient packaging, even if the merchandise is insured. Print the RA number prominently on the top of the package.

Prepay shipping. Insure the package. Send it to Carson Warranty Service, 35 Gilpin Ave., Hauppauge NY 11788. Merchandise must be shipped prepaid. Carson will not accept merchandise C.O.D.

Free Manuals Download Website

<http://myh66.com>

<http://usermanuals.us>

<http://www.somanuals.com>

<http://www.4manuals.cc>

<http://www.manual-lib.com>

<http://www.404manual.com>

<http://www.luxmanual.com>

<http://aubethermostatmanual.com>

Golf course search by state

<http://golfingnear.com>

Email search by domain

<http://emailbydomain.com>

Auto manuals search

<http://auto.somanuals.com>

TV manuals search

<http://tv.somanuals.com>