



**RED PLANET**  
SERIES

## **RP-200 TELESCOPE Instruction Manual**



**CARSON®**

Carson Optical  
35 Gilpin Avenue  
Hauppauge, NY 11788-4723  
Phone: 631-963-5000  
Fax: 631-427-6749

For information, call toll-free: 1-800-967-8427

[info@carsonoptical.com](mailto:info@carsonoptical.com) / [sales@carsonoptical.com](mailto:sales@carsonoptical.com) / [www.carsonoptical.com](http://www.carsonoptical.com)

## Table of Contents:

3	Box Contents
4-7	Figures 1-6 / Figure Key
8-9	Telescope Assembly <ul style="list-style-type: none"><li>• Setting up Your Tripod</li><li>• Attaching the Horizon Mount</li><li>• Attaching the Slow Motion Cables</li><li>• Attaching the Telescope Tube to the Mount</li><li>• Attaching the Finder Scope</li><li>• Attaching the Eyepieces</li><li>• Aligning the Finder Scope</li></ul>
10	Calculating Power
10	Understanding Celestial Movement
10-11	Using the Telescope
12	Care and Maintenance of Your Telescope <ul style="list-style-type: none"><li>• Cleaning</li></ul>
12	Specifications
13	Warnings
13	Customer Service
13-14	Warranty Information

Congratulations on your purchase of a Carson **RP-200 Red Planet Series™** telescope. This telescope features an easy-to-use design and high performance optics that are perfect for amateur astronomers looking to explore the wonders of outer space. Please read this manual carefully to ensure that you assemble and use your telescope correctly. When used properly, your **Red Planet™** telescope should provide years of exciting observations of the universe. Please note that this Refractor telescope was designed for both terrestrial and astronomical viewing.

**IMPORTANT: DO NOT USE YOUR RED PLANET™ TELESCOPE TO LOOK AT OR NEAR THE SUN! DOING SO WILL CAUSE INSTANT AND PERMANENT EYE DAMAGE.**

Each box contains the following:

- Complete Optical Tube Assembly.
- Horizon Mount.
- Heavy-Duty Aluminum Tripod.
- 9mm Kellner Eyepiece (1.25"O.D.).
- 20mm Kellner Eyepiece (1.25"O.D.).
- 45° Corner Lens
- 8x21mm Erecting Finder Scope.
- Flexible Cable Controls for Both Axes.

Please unpack your telescope carefully and make sure that all accessories are included in the box.

Fig.1

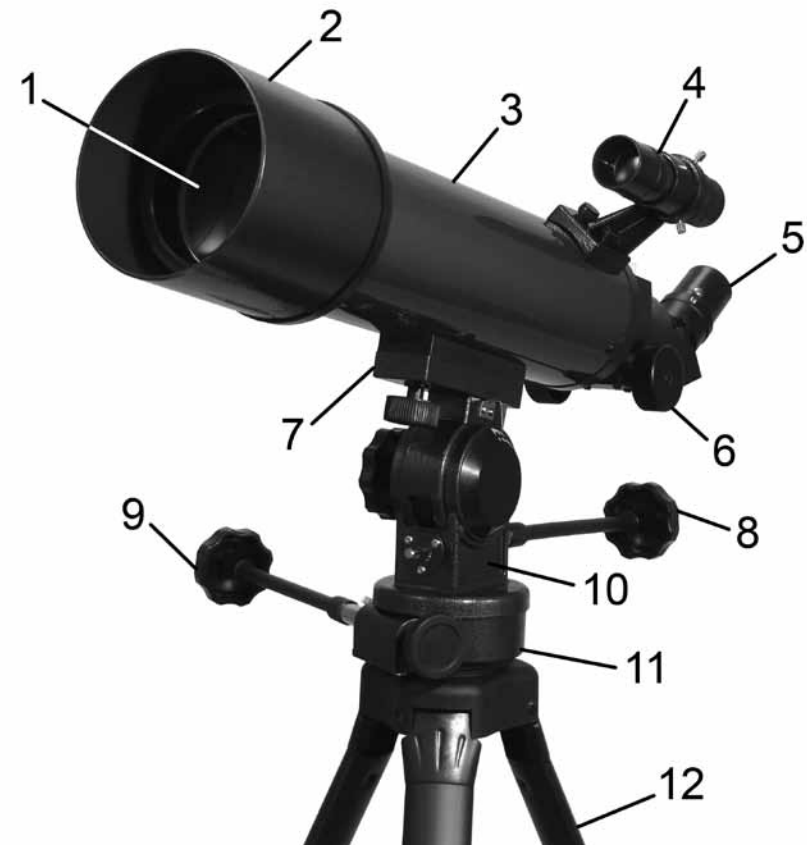

Fig.2

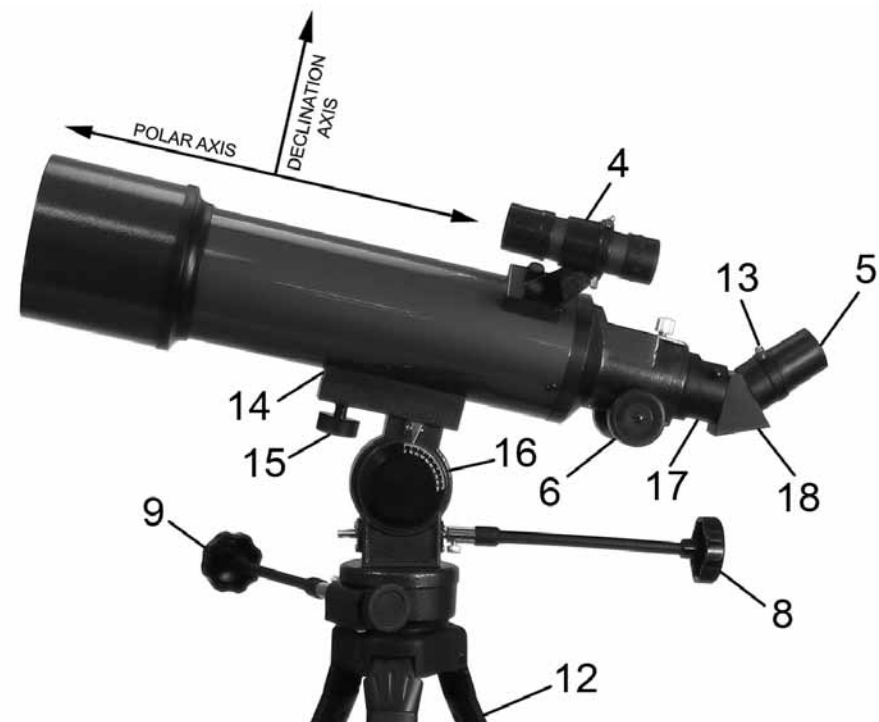

Fig.3

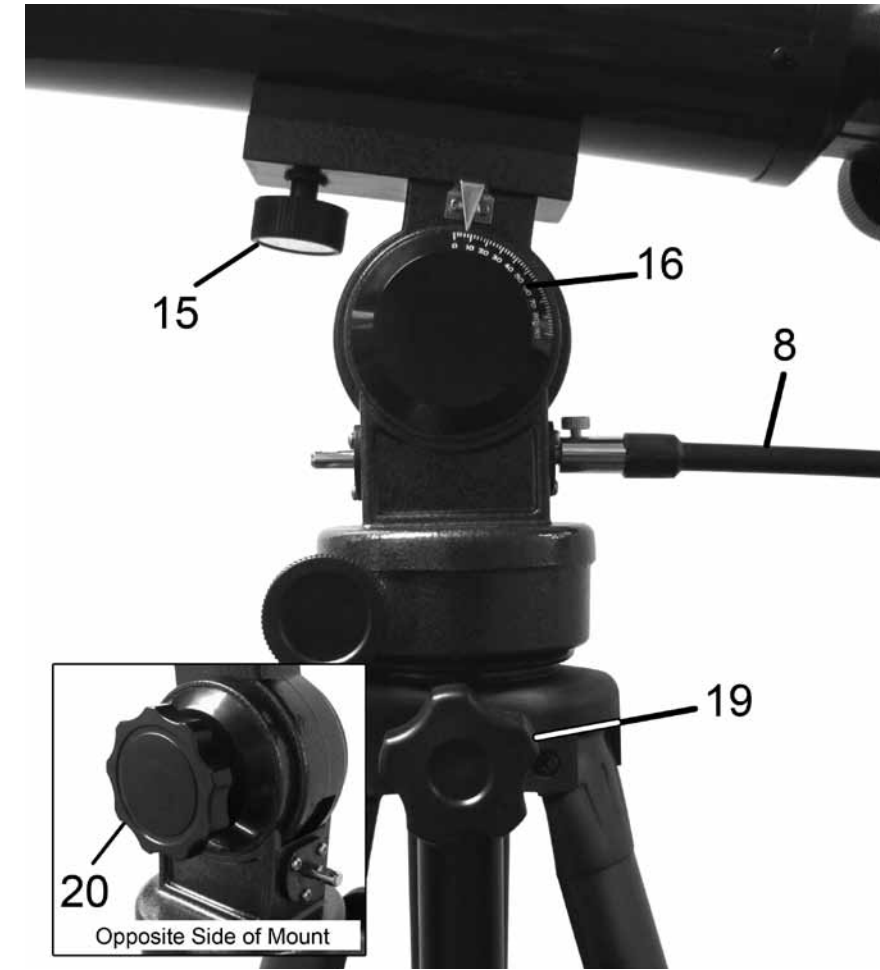

Fig.4

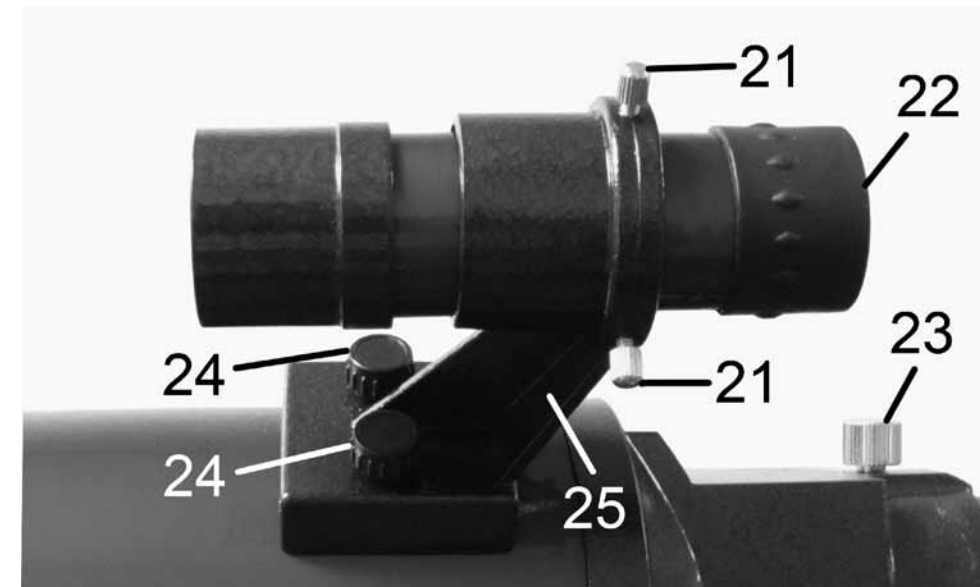

Fig.5

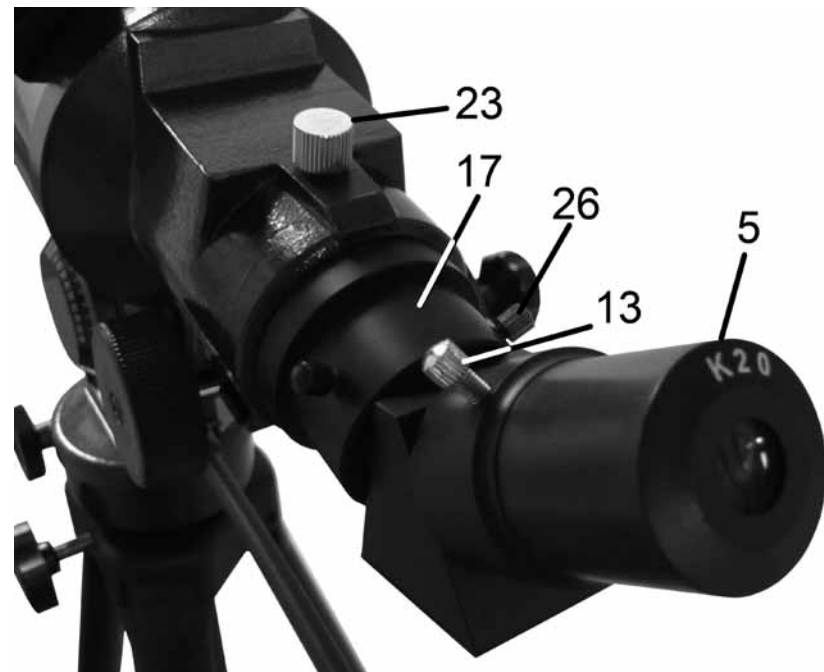
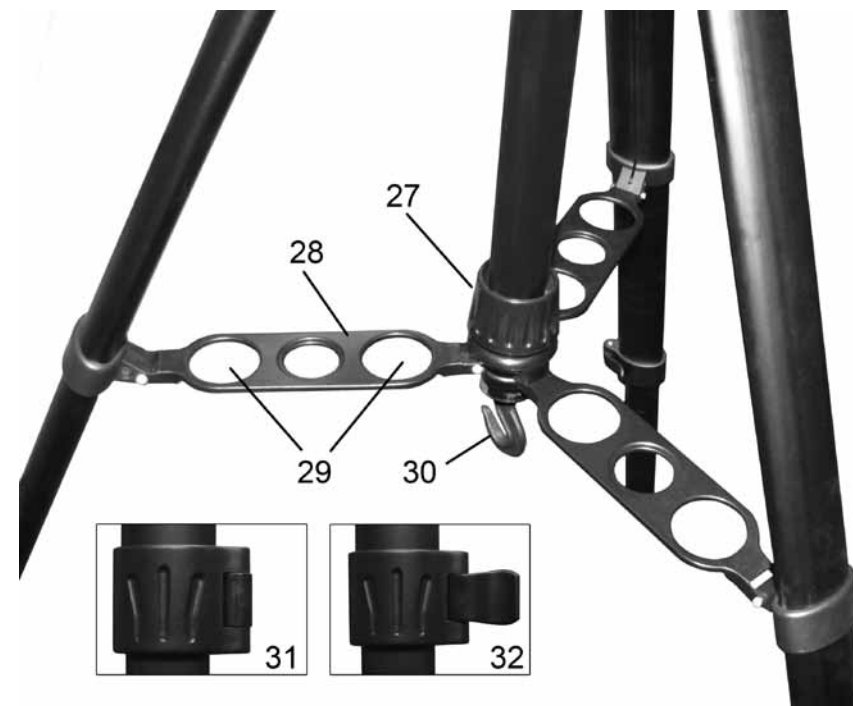

Fig.6



Key to Figures 1-6:

1. Objective Lens
2. Lens Shade
3. Optical Tube Assembly
4. 8x21mm Erecting Finder Scope
5. Eyepiece
6. Focus Knobs
7. Optical Tube Saddle Plate
8. Altitude Adjustment Flexible Cable
9. Horizontal Adjustment Flexible Cable
10. Horizon Mount
11. Horizon Mount Base
12. Tripod Legs
13. Eyepiece Holder Thumb Screw
14. Optical Tube Assembly Tripod Connector
15. Saddle Plate Lock
16. Altitude Dial
17. Focuser Draw Tube
18. 45° Corner Lens
19. Mount Locking Screw
20. Altitude Lock Knob
21. Finder Scope Bracket Thumbscrews
22. Finder Scope Focus Knob
23. Focuser Draw Tube Locking Screw
24. Finder Scope Bracket Thumb Screw
25. Finder Scope Bracket
26. 45° Corner Lens Thumb Screw
27. Tripod Tightening Ring
28. Tripod Brace
29. Eyepiece Holder Slots
30. Tripod Hook
31. Tripod Leg Lock Closed
32. Tripod Leg Lock Open

## Assembly of your Red Planet Telescope:

### Setting Up Your Tripod:

The aluminum tripod comes preassembled and ready-to-use. Remove the tripod from the box and pull apart the legs. Gently push down the tripod braces (Fig. 6-28) until they are in the lowest position. Turn the tightening ring (Fig. 6-27) (located at the center of the Tripod Brace) clockwise to lock the tripod in the open position. You can then extend the legs to the desired height by pulling open the tab on each leg lock (Fig. 6-32), sliding the leg down the desired amount and then pushing the leg lock back against the leg into the locked position (Fig. 6-31). Repeat the process with each leg trying to keep the tripod as level as possible with the ground. You will notice there are holes in the tripod leg braces (Fig. 6-29). These are designed to hold eyepieces when not in use.

### Attaching the Horizon Mount:

Remove the horizon mount (Fig. 1-10) from the box and place the bottom of the mount (Fig. 1-11) into the hole in the top of the tripod head and secure with the mount locking screw (Fig. 3-19). Please be careful to make sure that the mount is securely attached to the tripod.

### Attaching the Slow Motion Cables:

Locate the two slow motion cables (Fig. 1-8,9). Loosen the screw at the end of each cable so that it does not protrude through the hole. Slide one cable onto the shaft on the side of the horizon mount (Fig. 1-9) (located closest the bottom of the mount) and tighten down with the locking screw. Slide the remaining cable onto the altitude adjustment shaft (Fig. 1-8) (located near the middle of the mount) and tighten down with the locking screw. These slow motion cables will allow you to make fine pointing adjustments to the telescope both horizontally and vertically. This will be discussed in more detail later.

### Attaching the Telescope Tube to the Mount:

The top of the equatorial mount is called the optical tube saddle plate (Fig. 1-7). Pull and hold down on the saddle plate lock (Fig. 2-15) and slide the bracket attached to the bottom of the optical tube assembly (Fig. 2-14) into the saddle plate until the saddle plate lock clicks into place. Tighten the saddle plate lock to secure the optical tube in place.

### Attaching the Finder Scope:

There are two finder scope bracket mounting bolts (Fig. 4-24) located at the end of the optical tube near the eyepiece assembly. Remove the nuts and set aside. Place the finder scope bracket (Fig. 4-25) onto the mounting bolts, replace the nuts and tighten down securely to the optical tube. Make sure the bracket is facing forward as shown in Fig. 4. Slide the finder scope (Fig. 1-4) into the bracket facing forward.

### Attaching the Eyepieces:

Insert the 45° corner lens (Fig. 2-18) into the focuser draw tube (Fig. 2-17) and secure into place by tightening the corner lens thumbscrew (Fig. 5-26). Insert the Kellner 20mm eyepiece (Fig. 2-5) into the corner lens (Fig. 2-18) and tighten down using the eyepiece holder thumb screw (Fig. 2-13).

You have now completed the assembly of your Red Planet™ telescope. We will now need to make the necessary adjustments in order to use your telescope properly.

### Aligning the Finder Scope:

The low power and wide field of view provided by the 8x21mm finder scope (Fig. 1-4) provides a quick and easy way to sight an object prior to looking through the high-power telescope. The finder scope must first be properly aligned with the telescope in order to work properly. This alignment is best performed during the daylight. Follow the steps below to align your finder scope properly:

- Place the Kellner 20mm eyepiece (Fig. 2-5) into the corner lens (Fig. 2-18) of the telescope.
- Loosen the altitude lock knob (Fig. 3-20) so that the telescope swings freely along both axes.
- Point the main telescope at a specific land object 200 yards or more away. Lock down the altitude axis. Turn the slow motion cables (Fig. 1-8,9) until the object is centered in the telescope field.
- Now look through the finder scope (Fig. 1-4) and loosen or tighten the finder scope bracket screws (Fig. 4-21) until the crosshairs are centered on the same object. Focus by turning the finder scope focus knob (Fig. 4-22) until the image in the finder scope is sharp and clear.
- Check the alignment at nighttime by repeating this process with a bright star or the moon. Make any necessary adjustments.

Now that your finder scope is properly aligned, any object centered in your finder scope should also be centered in your telescope.

## Calculating Power:

The magnification of a telescope depends on both the focal length of your telescope as well as the eyepiece you use. There is a simple formula you can use to determine the magnification you are using at any given time. Simply divide the focal length of the telescope by the focal length of the eyepiece. For example, if you are using the 20mm eyepiece with your TP-200 telescope the power would be:

$$\text{Power} = 500\text{mm} / 20\text{mm} = 25\text{x}$$

Using an eyepiece with a smaller focal length will increase the magnification of your telescope. It is always best to start at the lowest magnification configuration. The wider field of view makes it easier to spot far away objects. Once an object is centered in your field of view you can switch to the higher power configurations.

## Understanding Celestial Movement:

In order to get the most enjoyment out of your telescope it is necessary to know the basics of how celestial objects move across the sky. Due to the rotation of the earth, celestial objects appear to move from East to West across the sky, much like the Sun. You will notice this movement as an object in your telescope field of view will slowly move across the field and out of view. Continuous adjustment is needed to keep an object in the field of view.

## Using the Telescope:

Once you have properly assembled and aligned your telescope you are finally ready to start using it.

- To locate an object using the telescope, first loosen the altitude lock (Fig. 3-20) allowing the telescope to rotate along both axes. Look through the finder scope (Fig. 1-4) to sight the object you are looking for and center it in the finder scope cross-hairs. You may need to focus the finder scope by turning the finder scope focus knob (Fig. 4-22). Then re-tighten the altitude lock.
- It is best to use the lowest power eyepiece (the Kellner 20mm eyepiece) at first. This allows for a wider field of view making it easier to locate objects. Once the object is centered in the field of view you can switch the eyepiece to higher magnifications.

- Once the object is centered in the field of view, turn the focus knobs (Fig. 1-6) until the image is clear and sharp. If the focus knobs are locked, loosen the focuser draw tube lock (Fig. 5-23) before turning the knobs.
- You will notice that the object you are viewing will slowly move across the field of view (caused by the rotation of the Earth). You will need to turn the slow motion cables (Fig. 1-8,9) to keep the object centered.
- The orientation of the image you see through both the finder scope and eyepiece of this telescope is normal. This allows you to use this telescope effectively when viewing terrestrial as well as astronomical objects.

There are many conditions that may affect your ability to focus or observe celestial objects clearly.

- Brightly lit areas (light pollution) will make it difficult to see faint objects in the sky. It will also make it difficult for your eyes to adjust to the dark. You should try and find a dark area and allow your eyes to adjust to the dark before making observations. Using a red filtered flashlight to view charts and your telescope components is recommended to preserve your night sight. The best viewing conditions are when the sky is inky black.
- Hazy skies, pollution, clouds and moisture can all affect the clarity of your viewing image.
- Avoid touching the eyepiece or optical tube while looking through the telescope. The vibrations caused by this contact will cause the object you are looking at to move. You should also make sure that the surface you place your telescope on does not vibrate or move as this will also cause your viewing object to move.
- You should avoid setting up your telescope inside a room looking through an open window. The difference in air temperatures may result in a blurry image.
- Viewing through a closed window might also result in a distorted image due to the varying densities of window glass.
- Avoid viewing objects that are low on the horizon. Objects that are higher up in the sky will appear much sharper.
- Sudden changes in temperature may cause condensation to appear on the optical components of the telescope. It is best to set up your telescope ahead of time and then wait while the telescope adjusts to the new temperature before using it.

## Care and Maintenance of Your Telescope:

### Cleaning:

- Always replace dust covers and lens caps when not in use. This will minimize the amount of dust and debris that gets into your telescope.
- Cleaning should be performed only if absolutely necessary. If dust has built up on the optics use a soft camel's hair brush or pressurized air to gently remove it.
- To remove dirt, grease or fingerprints, clean with a soft cotton cloth rubbing in a circular motion. Use of a coarse cloth or unnecessary rubbing may scratch the lens surface and eventually cause permanent damage.
- For a more thorough cleaning, photographic type lens cleaning fluid may be used. Always apply the fluid to the cleaning cloth, never directly on the lens.
- Avoid touching the surface of the objective lens.
- Do not attempt to take apart your telescope to clean it.

## Specifications:

Optical Design:	Refractor
Aperture:	80mm (3.15")
Focal Length:	500mm (19.69")
Focal Ratio:	6.25
Optical Coatings:	Fully Coated
Finder Scope:	8x21mm Erecting
Eyepiece 1:	Kellner 9mm
Magnification 1:	56x
Eyepiece 2:	Kellner 20mm
Magnification 2:	25x
Accessory:	45° corner Lens
Mount:	Horizon
Weight:	7.8 lbs.

## Warnings:

- Never use this telescope (or its viewfinder) to look directly at or near the sun. Viewing the sun can cause instant and irreversible eye damage.
- Always supervise children when using this telescope.
- Do not leave telescope unattended at any time. Untrained adults or children may not be familiar with the correcting operating procedure.
- Do not point the telescope at the sun even when you are not looking through it. This will cause internal damage to the telescope.
- Handle this telescope with care. Rough handling might knock the internal optical components out of alignment.

## Customer Service:

We will be happy to help you with any problems you may experience while using your telescope. Please call our toll-free customer service line at 1-800-967-8427.

## Warranty Information:

This Carson product is warranted to be free from defects in material and workmanship for a period of one year from date of purchase. During this period Carson will, at its option and without charge, either repair any part or assembly of parts found to be defective in material or workmanship, or replace this Carson product with a Carson product of comparable value and condition, subject to the limitations and exclusions noted herein.

This warranty extends to the original purchaser only and is not assignable or transferable. It shall not apply to any product that has been subject to misuse, abuse, negligence or accident, or to any defects or damage directly or indirectly caused by the use of unauthorized replacement parts and/or service performed by unauthorized personnel.

This warranty gives you specific legal rights, and you may also have other rights which could vary from state to state. Some states do not allow limitations on the life of an implied warranty and/or do not allow excluding or limiting incidental or consequential damages. If so, the above limitations or exclusions may not apply to you.

**Warranty Procedure:**

Provide proof of purchase. A receipt or other dated proof of purchase must be included with merchandise being returned for a warranty claim to be processed.

Call or write for authorization. Before returning any product for a warranty claim, a Return Authorization (RA) number must be obtained. No merchandise will be accepted without an RA, and failure to obtain an RA will prevent or delay processing of the warranty claim. To obtain an RA call 631-963-5000, or write to Carson Warranty Service, 35 Gilpin Ave, Hauppauge NY 11788 with a description of the problem. Include your name, address and telephone number.

Package the return carefully. Shippers will not reimburse for damages due to insufficient packaging, even if the merchandise is insured. Print the RA number prominently on the top of the package.

Prepay shipping. Insure the package. Send it to Carson Warranty Service, 35 Gilpin Ave., Hauppauge NY 11788. Merchandise must be shipped prepaid. Carson will not accept merchandise C.O.D.



## Free Manuals Download Website

<http://myh66.com>

<http://usermanuals.us>

<http://www.somanuals.com>

<http://www.4manuals.cc>

<http://www.manual-lib.com>

<http://www.404manual.com>

<http://www.luxmanual.com>

<http://aubethermostatmanual.com>

Golf course search by state

<http://golfingnear.com>

Email search by domain

<http://emailbydomain.com>

Auto manuals search

<http://auto.somanuals.com>

TV manuals search

<http://tv.somanuals.com>