

740

Articulated Truck



Engine

Engine Model	Cat® C15 ACERT™	
Gross Power – SAE J1995	350 kW	469 hp
Net Power – SAE J1349	338 kW	453 hp

Weights

Rated Payload	39.5 tonnes	43.5 tons
---------------	-------------	-----------

Body Capacities

Heaped 2:1	24 m ³	31.4 yd ³
------------	-------------------	----------------------

740 Articulated Truck

The 740 Caterpillar® Articulated Truck is a world-leading earthmoving solution.

Cat® C15 Engine with ACERT™ Technology

The core concept behind ACERT™ technology is advanced combustion. ACERT engine technology carefully controls the combustion process to reduce pollutant levels while maintaining performance and efficiency. **pg. 4**

Durability and Reliability

The 740 has built-in durability and reliability. Cat purpose-built articulated truck drivetrain components, front frame and hitch ensure maximum performance in the toughest applications. **pg. 9**

Performance and Productivity – Power Train

The Cat® C15 ACERT engine, matched with the seven-speed forward and two-speed reverse electronic controlled transmission, provides a wide operating range for smooth shifting. **pg. 5**

Serviceability

Long service intervals and easy maintenance provide better machine availability, resulting in lower owning and operating costs. **pg. 10**

Performance and Productivity – Suspension and Traction Control

Three-point front suspension provides a smooth ride, allowing the operator to travel at speed over rough terrain. Cross-axle differential locking system provides full driveline locking for maximum performance in adverse conditions. **pg. 6**

The 740 offers proven reliability and durability, high performance, low fuel consumption, operator comfort and low operating costs.



Performance and Productivity – Body Capacity

- ✓ Increased payload capacity for improved productivity. **pg. 6**

Operator Comfort

Large center-mounted cab, oscillating front axle, air suspension seat, full-size trainer seat and large storage space provide exceptional operator comfort. **pg. 7**

Ease of Operation

Ergonomically designed wrap-around dash, tilt and telescopic steering wheel, easy-to-reach controls and outstanding all-around viewing promote fast, confident machine operation. **pg. 8**

Product Link

- ✓ Satellite technology provides machine data via the internet giving you critical information and enabling Cat dealer World Class services. **pg. 11**

Complete Customer Support

Your Cat dealer offers a wide range of services that can be set up under a customer support agreement when you purchase your equipment. The dealer will help you choose a plan that can cover everything from machine configuration to eventual replacement. **pg. 12**



✓ *New Feature*

Cat C15® Engine with ACERT™ Technology

A combination of proven systems and innovative new technologies, ACERT engines optimize performance while meeting EPA Tier 3 and EU Stage IIIa engine exhaust emission regulations.



ACERT Technology. The Cat® C15 ACERT™ engine introduces a series of evolutionary, incremental improvements that provide breakthrough engine technology built on systems and components developed by Caterpillar with proven reliability. The technology capitalizes on Cat expertise in four core engine systems: fuel, air, electronics and after treatment. ACERT technology is a unique and revolutionary systems solution that enables Cat engines to meet today's clean air regulations, thus establishing the building blocks for attaining tomorrow's more stringent standards.

C15 Block. The one-piece, gray iron block features generous ribbing for stiffness and heavy bearing bulkheads for rigidity and strength as the crankshaft turns. Straight O-ring connection points reduce the loss of engine oil and fluids.

Cylinder Head and Piston Technology.

The C15 ACERT engine has a cross-flow cylinder head with refined port geometry, which provides improved breathing and better combustion. The Monotherm/steel pistons have a forged steel design, which offers high strength, light weight and tighter tolerances. The result is better oil control, minimal blow-by and long liner life.

Advanced Diesel Engine Management (ADEM) A4 Engine Controller.

The ADEM™ A4 electronic control module manages fuel delivery to get the best performance per liter or gallon of fuel used. The engine management system provides flexible fuel mapping, allowing the engine to respond quickly to varying application needs. It tracks engine and machine conditions while keeping the engine operating at peak efficiency.

Fuel Delivery. Multiple injection fuel delivery involves a high degree of precision. Precisely shaping the combustion cycle lowers combustion chamber temperatures, generating fewer emissions and optimizing fuel combustion. This translates into more work output for your fuel cost.

Noise Reduction Technologies.

Noise reduction has been achieved through design changes to the isolated top cover, oil pan, multiple injection strategy, insulated timing case cover, sculpted crankcase and gear train refinements.

Performance and Productivity – Power Train

Integrated power train with more power, greater performance and lower fuel consumption – the power to do more work.

Mechanically Actuated Electronic Unit Injection (MEUI). A highly evolved fuel system with a proven record of reliability in the field. It combines the technical advancement of an electronic control system with the simplicity of direct mechanically controlled unit fuel injection. It excels in its ability to control injection pressure over the entire engine operating speed range. These features allow the C15 to have complete control over injection timing, duration and pressure.

Air-to-Air Aftercooling (ATAAC). ATAAC keeps air intake temperatures down and, in concert with the tight tolerance combustion chamber components, maximizes fuel efficiency and minimizes emissions. Significant improvements in air flow are generated by a turbocharger, unique cross-flow head and a single overhead camshaft.

Wastegate Turbocharging. Single wastegate turbocharger provides higher boost over a wide range, outstanding low-end performance with improved peak torque and engine response.

Electronic Transmission. The Caterpillar seven-speed electronically controlled transmission is designed specifically for the articulated truck and its applications. It features anti-hunt shift strategy for speed continuity. It also incorporates Individual Clutch Modulation (ICM) to ensure constant shift times even when the oil is cold.

Two Reverse Gears. The transmission arrangement provides a second reverse gear for improved performance when operating in longer rear hauling applications. First gear reverse is now of a lower ratio for increased rimpull on wet or steep grades.



Controlled Throttle Shifting (CTS). Significantly reduces power train stress and clutch wear by controlling engine speed, torque converter lock-up and transmission clutch engagements.

Engine Overspeed Inhibitor. Electronic Engine Overspeed Inhibitor. Electronic Transmission Control (ETC) protects against engine overspeeding by shifting the transmission up one gear at specified rpm settings. If the transmission is in its highest gear, torque converter lockup disengages.

Directional Shift Management. Regulates engine speed during directional shifts to prevent damage caused by high-speed directional changes.

Programmable Top Gear Selection. Electronic Transmission Control lets you electronically limit top gear selection without the use of additional service tooling or mechanical limiting of the shift cane.

Caterpillar Engine Compression Brake. Provides extra braking effort on downhill grades. It is an excellent match for the C15 ACERT engine, turning it into a power absorbing air compressor. It has very fast response time and produces no additional heat, so it can be used continuously.

Usable Rimpull. Power train components work together to offer more usable rimpull at higher speeds on effective grades. In first gear, the torque converter overcomes grade resistance by sending more torque to the wheels and preventing engine lugging. On downhill grades, the engine compression brake works like a brake by slowing the machine.

Hydraulic Fan. The remote-mounted hydraulic fan is temperature sensitive providing variable speeds when needed, which minimizes power requirements. The result is more power to the ground and faster cycle times.

Performance and Productivity – Suspension and Traction Control

Suspension systems and traction control – delivering power to the ground in all conditions.

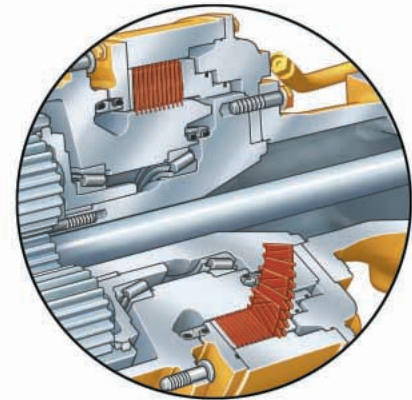
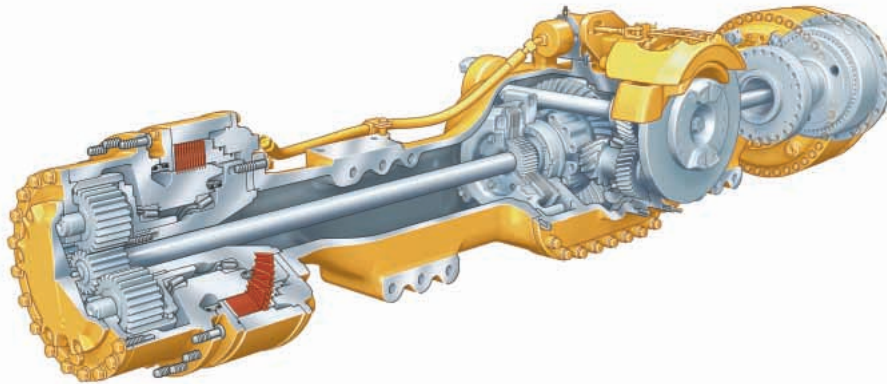

Service brake detail

Front Suspension. The three-point front suspension oscillates $\pm 6^\circ$ to provide a smooth ride, allowing the operator to travel at speed over rough terrain and softening impact loads on structures and components.

A-Frame Construction. The front suspension uses an oscillating A-frame with a lateral tie rod to control axle sideways movement. The independent low-pressure, oil-nitrogen suspension cylinders provide an excellent ride in rough conditions. Low pressure ensures consistent damping and increased seal life.

Front Suspension Cylinders. Large bore, low pressure cylinders are purpose designed for tough applications and offer a soft, smooth ride.

Mounting Points. Suspension mounting points are integrated into the axle housing, increasing reliability.

Rear Suspension. Features a walking beam geometry with Caterpillar designed rear suspension mounts which provide a reliable and stable ride for excellent load retention.

Traction Control. The traction control system is comprised of a wet clutched inter-axle differential and wet clutched cross-axle differentials. All differentials can be engaged and disengaged on-the-go for maximum versatility. When used together, the differentials provide 100 percent driveline locking.

Inter-Axle Differential Lock. Locks all three axles in unison and modifies torque distribution for excellent traction in poor underfoot conditions and on grades. It is operated by a switch located at the footrest.

Cross-Axle Differential Locks. Provides full driveline locking – all three axles and all six wheels – for maximum performance in the most adverse conditions. Acts in unison with the inter-axle differential lock when the footswitch is actuated and the dash-mounted switch is selected.

Fast Hoist Cycle Times. Fast body raise and lower times mean less time spent in the dump area.

Enclosed, Oil-Cooled Brakes.

Multi-plate, oil-immersed brakes are fitted to both front and center axles. These brakes provide outstanding stopping capability, while maintaining maximum durability and low wear characteristics.

Exhaust Heat System. The body comes exhaust heat ready.

Load-Carrying Capacity. The 740 has a large target area to provide consistently high load-carrying capacity. Its diverging flow design gives clean load ejection, which maximizes production and avoids the waste of material carry-back.

Operator Comfort

The operator's office – high productivity from a comfortable, motivated operator.



Ride Comfort. The three-point front suspension with its oscillating axle and low-pressure ride struts, combined with the center-mounted cab, offers unrivaled levels of ride comfort for the operator in all driving conditions. The operator remains comfortable and productive throughout the day.

Spacious Two-Person Cab. The 740 features a large two-person cab, offering comfortable working space for both the operator and trainer or trainee. All 700 Family articulated trucks use the same spacious cab design.

Air Suspension Seat. The air suspension seat enhances operator comfort with a cushioned upper high back, adjustable damping with three settings, ride zone indicator and adjustable lumbar settings. It is fully adjustable to provide the optimal driving position.

Storage Space. Plenty of storage space to create a safe, secure and uncluttered working environment.

Trainer Seat. Full-size trainer seat features a fully padded seat with a backrest and a wide, retractable seatbelt for a secure and comfortable ride. The trainer seat is positioned next to the operator seat, giving both the operator and trainer a clear view of the instrument panel, controls and the road.

Heating/Ventilation/Air Conditioning. Twelve vents provide air distribution to keep the operator comfortable and to provide rapid defrosting of all windows. Heating, air conditioning and defrosting are standard. The recirculation filter is positioned for easy servicing.

Radiator Mounting. The radiator is mounted at an angle to prevent heat transfer to the cab.

Dual-Sliding Window. The right-hand window is a dual-sliding window. Opening this window with the left rear hinged window provides cross-flow ventilation and enhanced operator comfort.

Sound Levels. Cab mounts are designed to reduce noise and vibration in the cab. All connections to the cab are resiliently mounted. The operator's station makes extensive use of sound-absorbing and barrier materials to keep sound levels low.

Steering Column. A comfortable driving position is provided by a telescopic and tilt steering column.

Ease of Operation

Designed for simple, easy operation, the 740 allows the operator to focus on production.



Ergonomic Layout. The controls and layout of the cab are designed to make it as easy to operate as your car. Quick, easy to read and simple to operate, the controls and gauges on the 740 allow the operator to concentrate on production.

Dash. The Generation II wrap-around dash puts all controls within easy reach of the operator. Featuring LED illuminated rocker switches, large LCD display and a rear wash wipe rocker switch. It provides an automotive feel with the industrial strength you would expect from Caterpillar.

Viewing Area. The low sloping hood and placement of the cooling package behind the cab give the operator excellent all-around visibility. The large glass area and central operator position also provide excellent visibility.

Wipers. The wet arm wiper system cleans more glass area and is bottom-mounted to keep it out of the operator's line of sight. Windows are tinted to reduce glare.

Differential Lock Controls. The inter-axle differential lock is engaged/disengaged by using a raised switch incorporated into the drivers foot rest, for ease of operation. For 100% lock up, all three cross-axle differential locks act in unison with the inter-axle differential lock when the foot switch is activated and a dash mounted switch is selected. Disengaging the foot switch opens all differential locks immediately.

Transmission and Hoist Levers.

The hoist lever provides easy, comfortable operation. The transmission lever offers excellent comfort, along with the control for top gear limit, transmission hold and neutral lock.

Suspended Pedals. Easy to operate and reach with plenty of leg and foot room. They also make for easier cleaning of the cab floor by keeping the pedals out of the dirt.

Cat 2S Monitoring System. Provides an improved method of monitoring critical machine functions and alerts the operator to an immediate or impending problem. The system includes four levels of warning.

Durability and Reliability

High availability leads to high productivity. Excellent durability keeps ownership costs low.

Front Frame. The front frame design features a large box section and wide, stiff frame beams to handle torque loads. The divergent frame design decreases stress in the hitch area and optimizes suspension geometry. The frame design makes maximum use of robotic welding for increased durability.

Rear Frame. Twin-box construction minimizes stress concentrations and provides low weight with long service life.

Castings. Both front and rear frames make extensive use of heavy-duty steel castings.

Suspension. The three-point oscillating axle front suspension provides unparalleled ride quality. It also protects the truck from the most adverse road conditions by absorbing shock loads that would otherwise reach the frame.

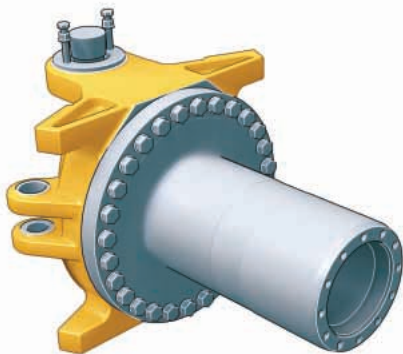

Articulating/Oscillating Hitch.

The articulating hitch provides the truck with steering articulation, and the oscillation ensures all-wheel ground contact in rough terrain.

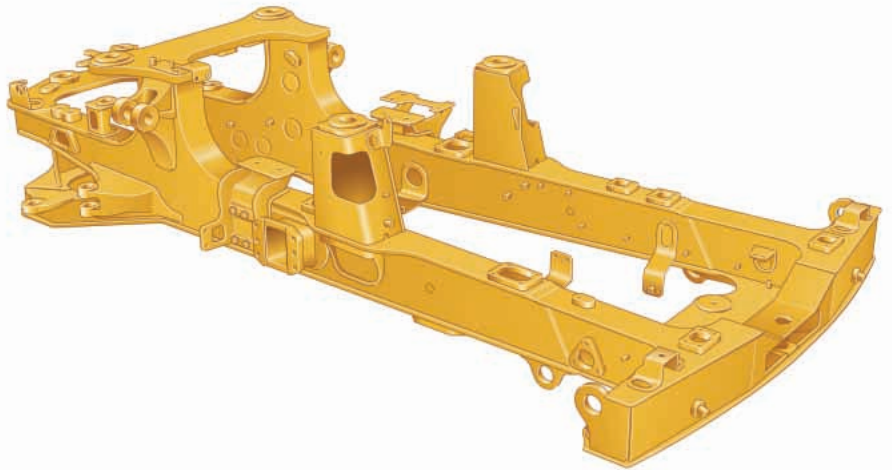

Hitch Construction. Two-piece construction features a strong, durable cast steel head bolted to a hard-wearing forged steel tube. The hitch tube has hardened bearing areas and a hardened thrust face for reduced maintenance and longer life.

Steer Cylinders In-Line with Hitch.

Steer cylinders are in-line with the hitch, minimizing steer loads and stress in the hitch area.

Service Brakes. Oil-cooled multiple disc brakes are continuously cooled for exceptional, non-fading braking. They are designed and built for reliable, adjustment-free operation.

Parking Brake. Located on the center axle in an elevated position and designed to deliver higher heat capacity and abuse resistance.

Cat Power Train Components. All major components have been purpose-designed for earthmoving applications. In fact, many of the major components have been designed specifically for articulated trucks.

Radiator Protection. The radiator is located behind the cab for excellent visibility. This design incorporates three levels of protection:

- 1) Body Spill Guard.**
- 2) Cab Steel Spill Guard.**
- 3) High-Strength Surround.**

Serviceability

More time on production, less time and money spent on servicing.



Long Service Intervals. Long engine oil change and hydraulic oil change intervals lower maintenance costs and downtime. Wheel-bearing adjustment is completely eliminated.

Lube Points. Lube points are grouped at the rear of the front frame and the front of the rear frame. Universal joints are lubed for life, eliminating servicing. Autolube is optional.

Service Points. Engine and transmission dipstick and fill caps, air and fuel filters, and the fuel priming pump are all mounted on the left side of the engine under the hood. Coolant level indicator and fill cap are outside the cab.

Radiator. The radiator package is located behind the cab, which provides protection from frontal impacts and offers easy access to the inlet and outlet sides of the radiator. The ATAAC radiator is located at the front of the truck.

Extended Life Coolant. Extends the change interval and improves component life by reducing aluminum corrosion.

Hood. The hood is raised and lowered electrically, minimizing operator effort when servicing the machine.

Electrical Service Center. Located inside the cab, this service center provides a power port, diagnostic connector and Cat Data Link connector.

Cat Data Link Connector. The Cat Data Link connector provides a plug-in using a laptop computer with Electronic Technician (ET) software. The Cat Data Link port performs programming functions on all electronic controls.

Service Access. The cab tilts to the side to provide easy access underneath, which simplifies servicing of the transmission, drive shafts and hydraulic pumps. Machine electrical and hydraulic interfaces are located on the right side of the cab, behind a removable cab body panel for easy access.

Integrated Transmission Package. The transmission integrates the transmission pump and torque converter into a single package. Because the transmission is an integral design, it eliminates many of the external hoses, resulting in less servicing and higher reliability.

Engine and Transmission Removal. The front frame design allows the engine and transmission to be removed and installed in one piece.

Truck Transport. The suspension system eliminates the need to lower the suspension when transporting the truck, reducing maintenance and downtime.

Output Transfer Gear. Provides lubrication of all bearings and clutches using a distributed-pressure lubricated and filtered system. Good lubrication and filtration reduce service and repair.

Product Link

Powered by Product Link, Equipment Manager is a secure user-friendly, application accessed via your Cat dealer's website.



Equipment Manager – a better way to manage your fleet. Equipment Manager allows transmitted data to be searched and sorted by alert level, group, equipment identification, make and model.

Depending on your information needs, Equipment Manager will:

- Report current equipment parameters (machine hours, location, fuel consumption, etc)
- Track all elements of machine maintenance and keep history
- Predict when a service is needed
- Facilitate maintenance scheduling and parts ordering
- Alert you to potential and immediate issues

Each new machine comes with Asset Watch. However, you can subscribe to a higher level of service for any machine, at any time, through your Cat dealer.

Equipment Manager combines key equipment indicators such as hours, location and diagnostic codes with powerful tools like mapping, maintenance and repair scheduling.

Asset Watch. Asset Watch manages your assets – enabling you to find your machine quickly, and to control its movement and work schedule.

Maintenance Watch. Maintenance Watch includes all the features of Asset Watch and will also help you plan, coordinate and track your repairs and maintenance, allowing you to align maintenance with machine usage more accurately.

Health Watch. Health Watch includes all the features of Asset Watch and will track machine operational conditions to help address potential issues before they become serious. You can also identify abuse, efficiency and training issues with individual operators.

Complete Customer Support

Cat® dealer services help you operate longer with lower costs.



Selection. Make detailed comparisons of the machines you are considering before you buy. What are the job requirements, machine attachments and operating hours? What is your need for machine availability and do you have the proper loading tool match? Your Cat® dealer can help.

Custom Product. The 740 is compatible with a wide range of Caterpillar and auxiliary equipment manufacturers' specialized products. For more information, contact your local Cat dealer.

Purchase. Look past the initial price, look at the value the 740 offers. Consider the resale value, compare productivity and day-to-day operating costs and fuel consumption. Consult your local Cat dealer for financing options.

Operation. For the best operating techniques to increase productivity and your profit, turn to your Cat dealer for the latest training literature and trained staff.

Maintenance. Repair option programs guarantee the cost of repairs up front. Diagnostic programs such as S•O•SSM and Technical Analysis help you avoid unscheduled repairs.

Replacement. Repair or rebuild? Cat articulated trucks are designed for longer life with rebuildable components. Your Cat dealer can help you evaluate the cost involved so you can make the right choice.

Product Support. The 740 offers easy maintenance with combined service points and extended service intervals to keep the machine running longer. Your local Cat dealership will be with you every step of the way with its unsurpassed worldwide parts support, trained technicians and customer support agreements.

Warranty. Your local Cat dealer is there to support and protect you. Extended warranty options are also available.

Cat.com. For more complete information on Cat products, dealer services and industry solutions, visit us on the Web at www.cat.com.

SAFETY.CAT.COM™.

Engine

Engine Model	Cat® C15 ACERT™	
Gross Power – SAE J1995	350 kW	469 hp
Net Power – SAE J1349	338 kW	453 hp
Net Power – ISO 9249	342 kW	458 hp
Net Power – EEC 80/1269	342 kW	458 hp
Flywheel Power	338 kW	453 hp
Bore	137 mm	5.4 in
Stroke	171.5 mm	6.75 in
Displacement	15.2 L	926 in ³

- The power ratings apply at rated speed of 1,800 rpm when tested under the conditions for the specified standard.
- The net power advertised is the power available at the flywheel when the engine is equipped with alternator, air cleaner, muffler and fan at minimum speed.
- Net power when the fan is at maximum speed is 330 kW (442 hp) per the SAE reference conditions.
- The 740 meets EPA Tier 3/EU Stage IIIa emission specifications for the U.S. and Europe through 2010.
- No engine derating required below 2438 m (8,000 ft.).

Weights

Rated Payload	39.5 tonnes	43.5 tons
---------------	-------------	-----------

Body Capacities

Heaped 2:1	24 m ³	31.4 yd ³
Struck	18.5 m ³	24.2 yd ³

Transmission

Forward 1	8.9 km/h	5.5 mph
Forward 2	12.1 km/h	7.5 mph
Forward 3	16.4 km/h	10.2 mph
Forward 4	22 km/h	13.7 mph
Forward 5	30 km/h	18.6 mph
Forward 6	40 km/h	25.1 mph
Forward 7	54.7 km/h	34 mph
Reverse 1	8.4 km/h	5.2 mph
Reverse 2	11.6 km/h	7.2 mph

Sound Levels

Interior Cab	79 dB(A)
--------------	----------

- The operator sound exposure Leq (equivalent sound pressure level) measured according to the work cycle procedures specified in ANSI/SAE J1166 OCT 98 is 79 dB(A), for the cab offered by Caterpillar, when properly installed and maintained and tested with the doors and windows closed.
- Hearing protection may be needed when operating with an open operator station and cab (when not properly maintained or doors/windows open) for extended periods or in noisy environments.

Operating Weights

Front Axle – Empty	19 400 kg	42,770 lb
Center Axle – Empty	7200 kg	15,873 lb
Rear Axle – Empty	6500 kg	14,330 lb
Total – Empty	33 100 kg	72,973 lb

Front Axle – Rated Load	5200 kg	11,464 lb
Center Axle – Rated Load	17 150 kg	37,809 lb
Rear Axle – Rated Load	17 150 kg	37,809 lb
Total – Rated Load	39 500 kg	87,083 lb

Front Axle – Loaded	24 600 kg	54,234 lb
Center Axle – Loaded	24 350 kg	53,683 lb
Rear Axle – Loaded	23 650 kg	52,139 lb
Total – Loaded	72 600 kg	160,055 lb

Body Plate Thickness

Front	8 mm	0.31 in
Scow	16 mm	0.63 in
Side	12 mm	0.47 in
Base	16 mm	0.63 in

Service Refill Capacities

Fuel Tank	532 L	140.5 gal
Cooling System	80 L	21.1 gal
Hydraulic System	328 L	86.6 gal
Engine Crankcase	38 L	9.5 gal
Transmission	72 L	19 gal
Final Drives/Differential	72 L	19 gal
Output Transfer Gear Box	18 L	4.8 gal

Body Hoist

Raise time	12 Seconds
Lower time	7 Seconds

Standards

Brakes	ISO 3450 – 1996
Cab/FOPS	ISO 3449 Level II – 2005
Cab/ROPS	ISO 3471 – 1994
Steering	ISO 5010 – 2007

Turning Circle

Dimensions are for machines equipped with 29.5R25 tires.

Turning dimensions

Steer angle — left/right	45°
SAE turning radius	8138 mm 320.4 in
Clearance radius	8595 mm 338.4 in
Inside radius	4101 mm 161.5 in
Aisle width	5694 mm 224.2 in

Steering

Lock to Lock 4.6 seconds @ 60 rpm

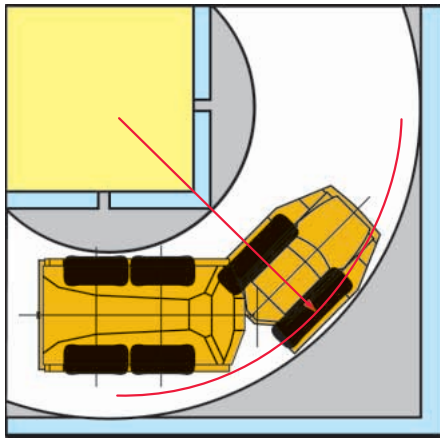

Dimensions

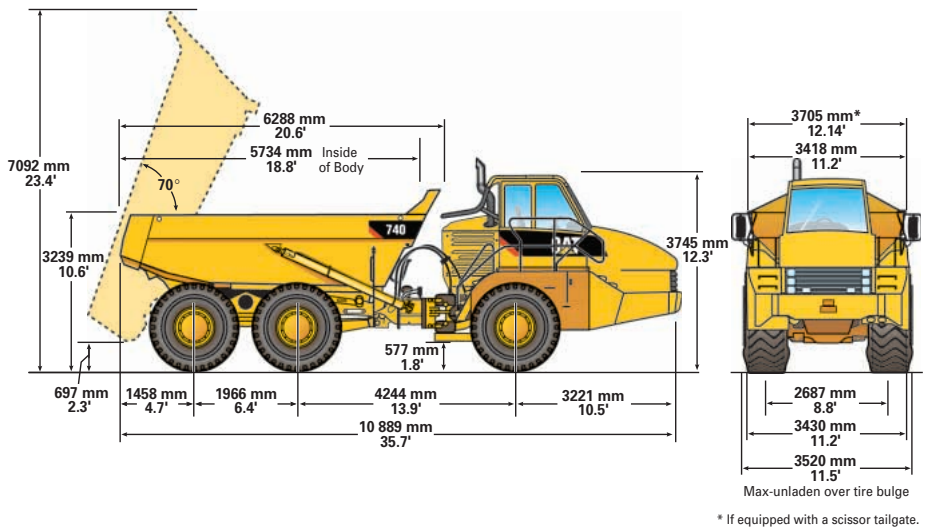

Optimal Loader/Truck Pass Matching

Hydraulic Excavators	385C	365C	345D
Loader Capacity (Tonnes) – 50 min hr	954-1193	750-1100	665-805
Loader Capacity (Tons) – 50 min hr	1049-1314	825-1210	735-885
Passes	3-4	5	6

Wheel Loaders	988H	980H	972H	966H
Loader Capacity (Tonnes) – 50 min hr	565-790	590-650	490-565	400-535
Loader Capacity (Tons) – 50 min hr	625-870	650-717	540-625	440-590
Passes	3-4	4	5	5-6

An optimum system match gives you a major productivity advantage. The 740 is an excellent match for the Cat 385C, 365C and 345C Hydraulic Excavators; and 972H, 980H and 988H Wheel Loaders. This results in increased production and lower system costs per unit of volume moved.

Gradeability/Speed/Rimpull

To determine performance, read from Gross Weight down to % Total Resistance. Total Resistance equals actual % grade plus 1% for each 10 kg/metric ton (20 lb/ton) of Rolling Resistance. From this point, read horizontally to the curve with the highest attainable speed range. Then, go down to Maximum Speed. Usable Rimpull depends on traction available.

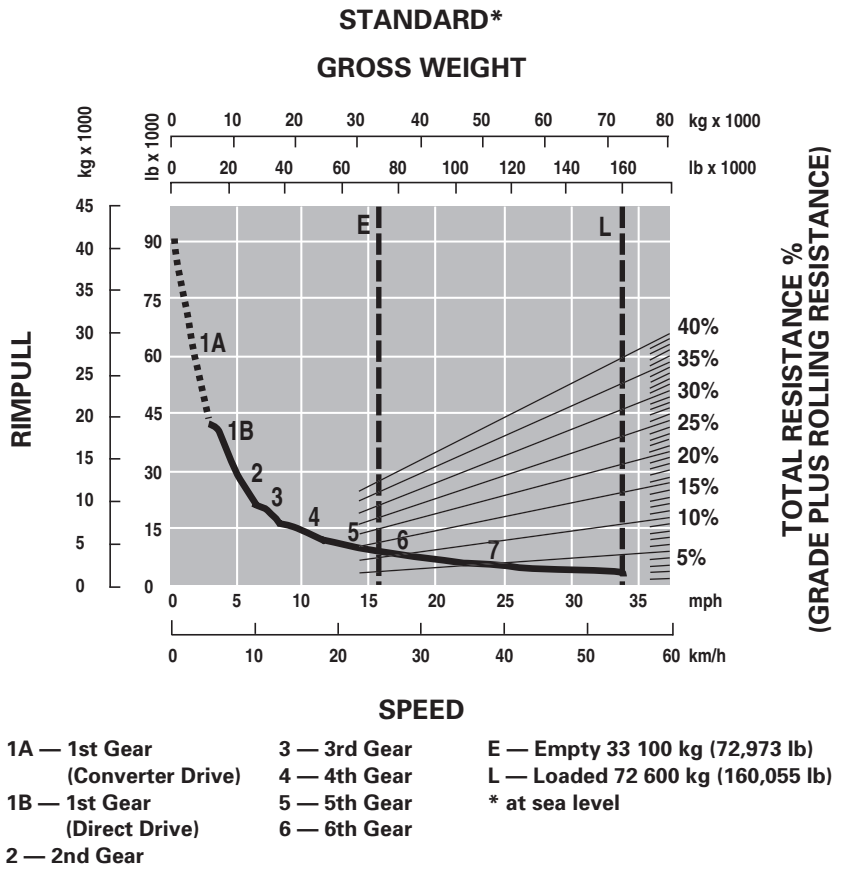

Retarding Performance

To determine performance, read from Gross Weight down to % Effective Grade. Effective Grade equals actual % favorable grade plus 1% for each 10 kg/metric ton (20 lb/ton) of Rolling Resistance. From this point, read horizontally to the curve with the highest attainable speed range. Then, go down to Maximum Speed. Retarding effect on these curves represents full application of the retarder.

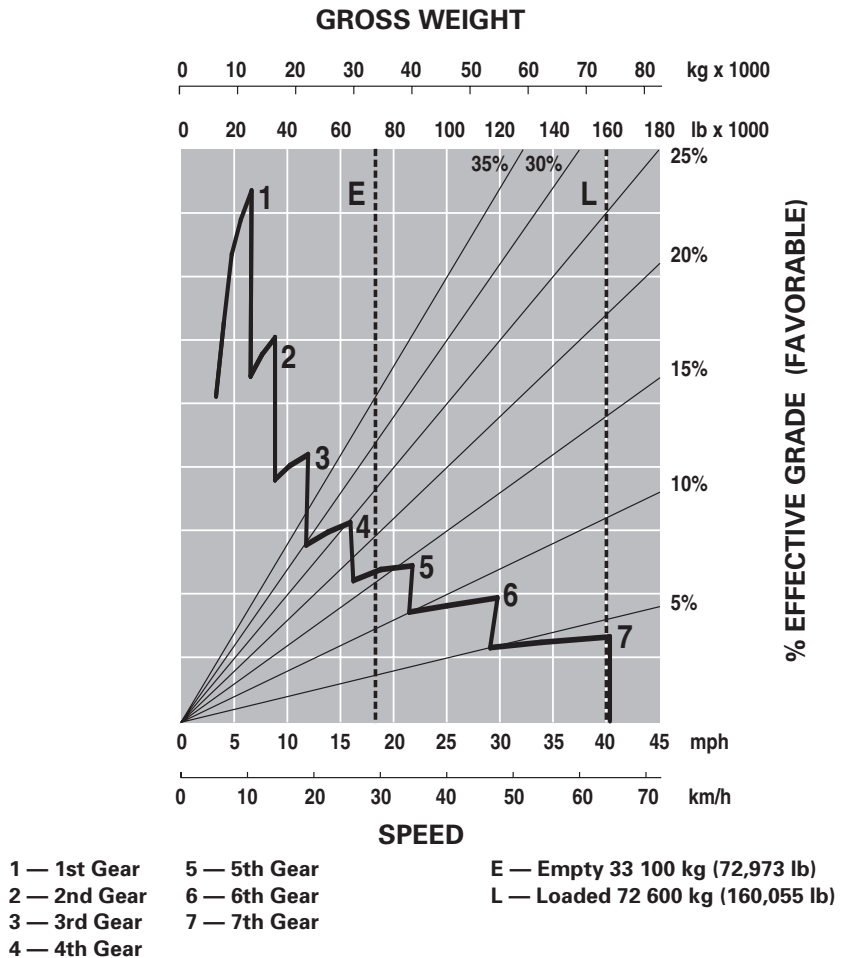

Standard Equipment

Standard equipment may vary. Consult your Caterpillar dealer for details.

- Air conditioning with R134A refrigerant
- Air vents, adjustable
- Auto shift seven-speed forward and two-speed reverse transmission
- Back up alarm
- Body, adapted for exhaust heat
- Cat C15[®] engine with ACERT[™] Technology
- CD/Radio, heavy duty
- Differentials, standard with clutched cross-axle differential locks for all axles
- Electrical system: 24 volt, 5A 24- to 12-volt converter
- Electro hydraulic hoist control
- Engine compression brake
- Ether starting aid
- Glass windows, laminated and tinted, front
- Glass windows, toughened and tinted, sides and rear
- Guards: rear window, radiator, crankcase and axle
- Headlights, four
- Heater and defroster with four-speed fan
- Horn, electric
- Lights: cab interior, front, side, rear, two reversing/working lights, two stop/tail lights, front and rear direction indicators
- Mirrors, main and auxiliary, left and right
- Mud flaps, wheel arch and body mounted, with transportation tie backs
- Oil-cooled brakes, enclosed
- Product Link
(US/Canada/Europe/Turkey/Australia/New Zealand)
- Retarder
- ROPS/FOPS cab, with full instrumentation, including:
 - Instrument cluster display module
 - Indicator lamps: left turn, secondary steering, primary steering loss, front and rear brake temp (735/740 and 740 Ejector only), brake oil pressure, action lamp, transmission fault, park brake, charging system status, differential lock, body not in float, right turn, high beam, transmission hold, machine filter warning, retarder, retarder up shift warning
 - Gauges: engine oil pressure, engine coolant temperature, torque converter oil temperature, fuel level, fuel tank level gauge
 - Meters: service hour meter, speedometer, tachometer
- Seat, fully adjustable, air suspension
- Seat, padded companion/trainer
- Seatbelts, two retractable
- Secondary steering – electronic
- S•O•SSM sampling valves
- Spill guard, front, integral part of fabricated body
- Starting receptacle, electric, remote
- Storage – two cup holders, flask receptacle, under seat storage, door pocket, behind seat storage, coat hook.
- Sun visor
- Three-axle, six wheel drive
- Tilt and telescopic steering wheel
- Tires, 29.5R25, radial
- Tow pins, front and rear
- Vandalism protection: lockable caps for fuel tank and hydraulic oil tank
- Windows opening side, tinted
- Windshield wiper and washer, two speed, intermittent (front)
- Windshield wiper and washer, two speed, (rear)

Optional Equipment

Optional equipment may vary. Consult your Caterpillar dealer for details.

Autolube installation for automatic greasing of bearings
Bath, oil pre-cleaner
Body liners
Caterpillar Work Area Vision System (WAVS)
 rear-view camera
CD/Radio, heavy duty
Cold Weather Coolant (–51° C/–60° F)
Cold weather start attachment
Cycle counter/operator monitoring kit
Engine Block Heater
Exhaust heated body

Extensions, fender
Fast fuel fill
Flashing Xenon Beacon
Fuel Additive – Anti-Waxing
Heated rearview mirrors
Product Link (Where Available)
Tailgate:
 – Scissor-type

Notes

740 Articulated Truck

For more complete information on Cat products, dealer services,
and industry solutions, visit us on the web at www.cat.com

© 2008 Caterpillar
All Rights Reserved
Printed in U.S.A.

Materials and specifications are subject to change without notice.
Featured machines in photos may include additional equipment.
See your Caterpillar dealer for available options.

AEHQ5649-03 (5-08)

Replaces AEHQ5649-02

CAT, CATERPILLAR, SAFETY.CAT.COM, their respective logos, "Caterpillar Yellow"
and the POWER EDGE trade dress, as well as corporate and product identity used
herein, are trademarks of Caterpillar and may not be used without permission.

CATERPILLAR[®]

Free Manuals Download Website

<http://myh66.com>

<http://usermanuals.us>

<http://www.somanuals.com>

<http://www.4manuals.cc>

<http://www.manual-lib.com>

<http://www.404manual.com>

<http://www.luxmanual.com>

<http://aubethermostatmanual.com>

Golf course search by state

<http://golfingnear.com>

Email search by domain

<http://emailbydomain.com>

Auto manuals search

<http://auto.somanuals.com>

TV manuals search

<http://tv.somanuals.com>