



# 345C L

Hydraulic Excavator



**CAT**<sup>®</sup>

---

**Cat<sup>®</sup> C13 Diesel Engine with ACERT<sup>™</sup> Technology**

<b>Net Power (ISO 9249) at 1800 rpm</b>	<b>239 kW/325 hp</b>
<b>Operating Weight</b>	<b>48 800 to 52 300 kg</b>
<b>Maximum Travel Speed</b>	<b>4.4 km/h</b>
<b>Maximum Reach</b>	<b>11.7 m</b>
<b>Maximum Digging Depth</b>	<b>7.5 m</b>

# 345C L Hydraulic Excavator

*High performance and rugged durability combine to maximize your productivity.*

---

## Engine

The Cat® C13 engine has state-of-the-art ACERT™ technology to meet emission regulations with exceptional performance capabilities, fuel efficiency and proven reliability. **pg. 4**

---

## Environmentally Responsible Design

Quieter operation, lower engine emissions, less fluid disposal and cleaner service can help you meet or exceed worldwide regulations and protect the environment. **pg. 4**

---

## SmartBoom™

More productive. Faster cycle times for truck loading and rock scraping. Maintains optimum hammering frequency for effective, steady productivity. **pg. 9**

## *Outstanding performance*

*Excellent control, high stick and bucket forces, impressive lift capacity, simplified service and a more comfortable operator station to increase your productivity and lower your operating costs.*

---

## Application and System Match

The 345C L is designed for matched performance with Cat articulated trucks. Five to six passes under two minutes, matched to the Cat 735 gives you maximum systems production. **pg. 5**

---

## Hydraulics

Hydraulic system has been updated to increase lifting and breakout forces. New Tool Control improves versatility. **pg. 5**

---

## Electronic Control System

ADEM™ A4 maximizes fuel efficiency and performance by maintaining the optimum balance between engine speed and hydraulic demand. **pg. 7**

---

## Operator Station

An all-new cab provides improved visibility and comfort. The new monitor is a full-color graphical display with enhanced functionality to provide simple, comprehensive machine interface. **pg. 6**



---

### **Booms, Sticks and Linkage**

Caterpillar excavator booms and sticks are built for performance and long service life. Two types of booms and four sticks are available, offering a range of configurations suitable for a wide variety of applications. The bucket linkage pins have been enlarged to improve reliability and durability. All booms and sticks are stress relieved. **pg. 11**

---

### **Undercarriage**

Cat designed excavator undercarriage is stable, durable and low maintenance. The undercarriage is a long, variable gauge type for good machine stability and transportability. **pg. 8**

---

### **Extreme Service**

Undercarriage attachment includes next size larger components for increased stability and extra rugged reliability in severe applications. **pg. 8**

---

### **Structures**

Caterpillar design and manufacturing techniques assure outstanding durability and service life from these important components and using thicker plates at the boom foot area to improve rigidity. **pg. 9**

---

### **Buckets, Quick Coupler, Work Tools**

A variety of work tools, including buckets, couplers, hammers, crushers, pulverizers, multiprocessors, shears and grapples are available through Cat Work Tools. **pg. 12**

---

### **Service and Maintenance**

Fast, easy service has been designed in with extended service intervals, advanced filtration, convenient filter access and user-friendly electronic diagnostics for increased productivity and reduced maintenance costs. **pg. 10**

---

### **Complete Customer Support**

Your Cat dealer offers a wide range of services that can be set up under a customer support agreement when you purchase your equipment. The dealer will help you choose a plan that can cover everything from machine and attachment selection to replacement. **pg. 10**



## Engine

*Built for power, reliability, economy and low emissions.*



**Performance.** The Cat C13 engine with ACERT Technology offers 21% greater displacement than the 3176C, and runs at 10% lower speeds for better fuel economy and reduced wear.

**Fuel Consumption.** ADEM A4 controller uses sensors throughout the engine to manage engine load and performance. The ADEM A4 controller is the muscle behind engine responsiveness, self-diagnostics, controlling emissions, and fuel economy.

**Low Sound and Vibration Levels.**

The engine mounts are rubber-isolating mounts matched with the engine package to provide optimum sound and vibration reduction. Another benefit of ACERT Technology, the C13 engine can shape the rate of fuel injection, a process that reduces engine noise levels and vibration.

**Fuel System.** The Cat C13 ACERT engine features electronic controls that govern the mechanically actuated unit fuel injection (MEUI) system. MEUI provides the high-pressure required to help reduce particulate emissions and deliver better fuel economy through finer fuel atomization and more complete combustion.

**Cooling System.** The 345C L layout separates the cooling system from the engine compartment. The cooling fan is hydraulically driven with a variable speed control that manages fan speed to provide optimized cooling.

**Air Cleaner.** The radial seal air filter features a double-layered filter core for more efficient filtration and is located in a compartment behind the cab. A warning is displayed on the monitor when dust accumulates above a preset level.

**Turbocharger.** The Cat C13 ACERT engine uses a Wastegate Turbocharger for improved performance.

**Cold Weather Starting Kit.** The kit consists of four batteries, heavy-duty harness, large capacity starting motor and the ether starting aid. With this kit, the 345C L has the capability to start at -32°C.

## Environmentally Responsible Design

*Caterpillar machines not only help you build a better world, they help maintain and preserve the fragile environment.*

**Outstanding performance.**

Many features designed to provide outstanding performance which can mean more work done in a day, less fuel consumption and minimal impact on our environment.

**Emissions.** ACERT Technology is a differentiated technology that reduces emissions at the point of combustion. The technology capitalizes on Caterpillar's proven leadership in three core engine systems: fuel, air and electronics.

**Quiet operation.** The hydraulically driven cooling fan is thermostatically controlled, so the fan only runs at the speed necessary to maintain correct system operating temperatures. The result is cool quiet operation with less disturbance to the surrounding environment.

**Ozone protection.** To help preserve the earth's ozone layer, the air conditioning unit uses only R-134a refrigerant which does not contain harmful chlorofluorocarbons (CFC's).

**Fewer leaks and spills.** Engine oil and encapsulated hydraulic oil filters are positioned vertically and are easy to reach to minimize spillage. Service intervals are extended to reduce the times fluids are changed and handled. The new hydraulic oil fine filtration system attachment extends the service interval from 2000 to 5000 hours. Compatible with Cat HEES hydraulic bio-oil for ecologically sensitive applications. Finally, the new Cat Extended Life Coolant extends service (up to 6000 h) so there is less need for fluid disposal.

## Applications and Systems Match

*The 345C L is designed for matched performance with Cat Articulated Trucks.*

### Wide range of front end attachments.

Providing choices for systems matching to a range of Cat articulated trucks from the 730 to the 740. This adds flexibility for a wide range of job conditions in a variety of applications such as construction, mining or quarry. Additionally, systems match offers versatility in job set-up whether top loading or same level truck loading.

### Optimum pass match design.

Five to six passes under two minutes, matched to the Cat 735, gives you maximum systems production at the lowest cost per ton of material moved.

### Maximum availability.

New standards for durability and reliability help ensure that your loading system has more uptime, operates efficiently and provides lasting value and high resale.



**Tool Control System.** The various settings allows you to optimize the excavator to the job layout. Five hydraulic pump flow and pressure setting can be preset, on the monitor, eliminating the need to adjust the hydraulics each time a tool is changed. The unique Cat proportional sliding switches provides modulation to the tool and the precision work easy.

**Quarry Package.** The new Quarry Package attachment consists of a bucket cylinder guard and reinforcement bars on the stick, for extra protection in the most severe conditions.

## Hydraulics

*Cat hydraulics deliver power and precise control to keep material moving.*

**Pilot System.** The hydraulic pilot system controls the front linkage, swing and travel operations.

**Component Layout.** The 345C L hydraulic system and component locations have been designed to provide a high level of overall system efficiency.

### Hydraulic Cross-Sensing System.

The two main hydraulic pumps use 100 percent of available horsepower resulting in faster implement speeds and increased productivity.

### Boom and Stick Regeneration Circuit.

Saves energy during boom-down and stick-in operation, providing shorter cycle times and lower operating costs.

**Boom and Swing Priority.** The hydraulic system on the 345C L provides automatic priority function for boom-up and swing operations eliminating the need for work mode buttons. When the boom or swing lever is activated, the system automatically assigns priority based on operator demand.

**Heavy Lift Feature.** The operator can select the heavy lift mode at the push of a button to boost lifting capability and provide improved controllability of heavy loads.

### Biodegradable Hydraulic Oil.

Biodegradable hydraulic oil is available as an option.

### Auxiliary Hydraulic Valve.

The auxiliary valve is standard. It is used with optional control arrangements to operate tools such as hammers and shears, shears, grapples, hammers, pulverizers, multi-processors and vibratory plate compactors.

### Hydraulic Cylinder Snubbers.

Snubbers are located at the rod-end of the boom cylinders and both ends of the stick cylinders to cushion shocks while reducing sound levels and extending component life.

## Operator Station

*Designed for simple, easy operation and comfort, the 345C L allows the operator to focus on production.*



**Cab Design.** The workstation is spacious, quiet and comfortable, assuring high productivity during a long work day. The air conditioner and attachment switches are conveniently located on the right-hand wall, and the key switch and throttle dial are on the right-hand console. The monitor is easy to see and maximizes visibility.

**Seat.** A new optional air suspension seat is available in the 345C L. The standard and optional seats provide a variety of adjustments to suit the operator's size and weight including fore/aft, height and weight. Wide adjustable armrests and a retractable seat belt are also included.

**Skylight.** An enlarged skylight with sunshade provides excellent visibility and good ventilation.

**Hydraulic Activation Control Lever.** For added safety, this lever must be in the operate position to activate the machine control functions.

**Climate Control.** Positive filtered ventilation with a pressurized cab comes standard. Fresh air or re-circulated air can be selected with a switch on the left console.

**Windows.** To maximize visibility, all glass is affixed directly to the cab eliminating the use of window frames. Choice of fixed or easy-to-open split front windshield meet operator preference and application conditions.

- 50/50 split front windshield allows both upper and lower portions to be stored in an overhead position.
- 70/30 split front windshield stores the upper portion above the operator. The lower front windshield features a rounded design to maximize downward visibility and improves wiper coverage.
- Both openable versions feature a one-touch action release system.
- The fixed front windshield is available in standard duty laminated glass or high impact resistant laminated glass.

**Wipers.** Parallelogram wiper, including a washer nozzle is mounted below the cab windshield, optimizes the operator's viewing area and offers continuous and intermittent modes.

**Monitor.** The compact, full-color, graphical display monitor, new with the 345C L, displays machine, maintenance, diagnostic and prognostic information, in twenty different languages. Monitor angle can be adjusted to minimize sun glare.

**Cab Exterior.** The exterior design uses thick steel tubing along the bottom perimeter of the cab, improving the resistance of fatigue and vibration. This design allows the FOGS to be bolted directly to the cab, at the factory or as an attachment later, enabling the machine to meet specifications and job site requirements.

**Cab Mounts.** The cab shell is attached to the frame with viscous rubber cab mounts, which dampen vibrations and sound levels while enhancing operator comfort.

## Electronic Control System

*Manages the engine and hydraulics for maximum performance.*



**Consoles.** Redesigned consoles feature a simple, functional design to reduce operator fatigue, ease of switch operation and excellent visibility. Both consoles have attached armrests and allow the height of the armrests to be adjusted.

**Standard Cab Equipment.** To enhance operator comfort and productivity, the cab includes a lighter, drink holder, coat hook, service meter, literature holder, magazine rack and storage compartment. The cab can be equipped with optional 12 volt converter and up to two 12V-7 amp electrical sockets to provide additional electrical resources.

**Machine Security.** An optional Machine Security System (MSS) is available from the factory. MSS uses a special Caterpillar key with an embedded electronic chip for controlling unauthorized machine operation.

**Product Link.** Product Link is now an attachment available from the factory on the 345C L.

**Travel Controls.** The 345C L uses pilot operated control levers, positioned so the operator can operate with arms on the armrests. The vertical stroke is longer than the horizontal stroke, reducing operator fatigue. The control lever grips are shaped to fit into the operator's hands. The horn switch and one-touch low idle switch are positioned on the left and right grip.

**Monitor Display Screen.** The monitor is a full color 400x234 pixels Liquid Crystal Display (LCD) graphic display.

The Master Caution Lamp blinks ON and OFF when one of the critical conditions below occurs:

- Engine oil pressure low
- Coolant temperature high
- Hydraulic oil temperature high

Under normal conditions or the default condition, the monitor display screen is divided into four areas; clock and throttle dial, gauge, event display and multi-information display.

**Clock and Throttle Dial Area.** The clock and the throttle dial position are in this area and the gas-station icon with green color is also displayed.

**Gauge Area.** Three analog gauges, fuel level, hydraulic oil temperature and coolant temperature, are displayed in this area.

**Event Display Area.** Machine information is displayed in this area with the icon and language.

**Multi-information Display Area.** This area is reserved for displaying information that is convenient for the operator. The "CAT" logo mark is displayed when information to display does not exist.

**Keypad.** The keypad allows operator to select machine operation conditions and to set view preferences.



## Undercarriage

*Durable undercarriage absorbs stresses and provides excellent stability.*



**Travel Motors.** Two-speed axial piston hydraulic motors provide the 345C L drive power and speed selection which is automatic when the high-speed position is selected. This enables the machine to automatically change between computer-controlled high and low speeds depending on drawbar-pull requirements.

**Straight-line Travel Circuit.** The straight-line travel circuit is incorporated into the hydraulic system, which maintains low-speed, straight-line travel, even when operating the front linkage. An optional straight travel pedal controls both tracks simultaneously.

**Final Drive.** The final drives are a new compact design with three-stage planetary reduction. This design results in a complete drive/brake unit that is compact and delivers excellent performance and reliability.

**Track Guards.** The idler guard and bolt-on center guard are standard equipment. They help maintain track alignment while traveling or working on slopes. For applications that require additional track protection or alignment, optional guards are available.

**Extreme Service Undercarriage.** Attachment includes next size larger track roller frame and moving undercarriage components for increased stability and extra rugged reliability in hard-rock and severe impact conditions.

**Fixed Gauge Undercarriage.** Attachment provides a stable, durable and low maintenance platform when working on variety of sites.

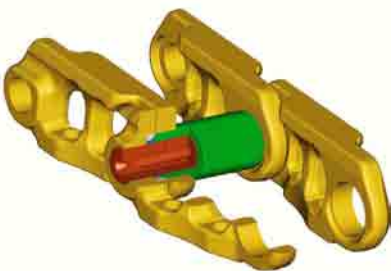

**Track.** The 345C L comes standard with the new grease lubricated track called GLT4. The track links are assembled and sealed with grease to decrease internal bushing wear, reduce travel noise and extend service life lowering operating costs.



## SmartBoom™

*Reduces stress and vibrations transmitted to the machine.*

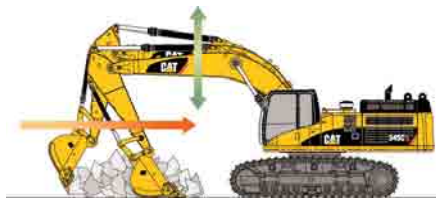

**Rock Scraping.** Scraping rock and finishing work is easy and fast. SmartBoom simplifies the task and allows the operator to fully concentrate on stick and bucket, while boom freely goes up and down without using pump flow.



**Hammer Work.** It has never been this productive and operator-friendly. The front parts automatically follow the hammer while penetrating the rock. Blank shots or excessive force on the hammer are avoided resulting in longer life for the hammer and the machine. Similar advantages are applicable when using vibratory plates.

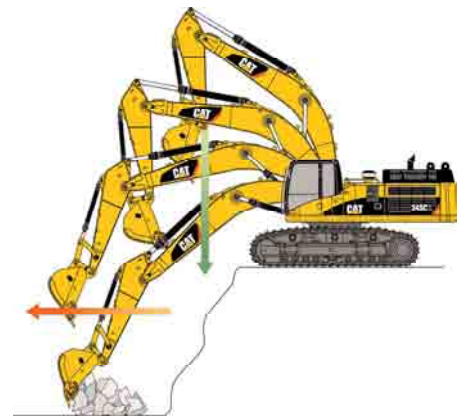

**Truck Loading.** Loading trucks from a bench is more productive and more fuel efficient as the return cycle is reduced while the boom down function does not require pump flow.



**Material Handling.** It is more efficient and productive due to faster return cycles. Unloading barges is easier because SmartBoom avoids excessive force being put on the floor of the barge allowing the operator to fully concentrate on production.

## Structures

*Structural components are the backbone of the machine's durability.*

**Carbody Design.** The advanced carbody design stands up to the toughest applications.

- Modified H-shaped, box-section carbody provides excellent resistance to torsional bending.
- Variable gauge undercarriage has track roller frames which are bolted to the carbody and can be retracted for shipping.
- Robot-welded track roller frames with fabricated U-section design.
- Robot welding ensures consistent, high-quality welds throughout the manufacturing process.

**Upper Frame.** The rugged main frame has been narrowed to improve transportability and is designed for maximum durability. Robot welding is used for consistent, high-quality welds. The main channels are box sections connected by a large diameter tube in the boom foot area to improve rigidity and strength. The outer frame utilizes curved side rails for rigidity against bending and torsional loads.

**Track Roller Frames.** The track roller frame is made of thick steel plate that is bent into a U-shape and welded to the bottom plate to create a box structure. The box structure design provides increased rigidity and impact resistance.

### **Variable Gauge Undercarriage.**

The long variable gauge undercarriage is standard, providing a wide, stable base for operating, or a narrow gauge for reduced shipping width. The track roller frames are bolted to the carbody, and can be placed in two positions.

## Service and Maintenance

*Simplified service and maintenance save you time and money.*



### **Extended Service Intervals.**

Extended service and maintenance intervals increase machine availability. The maintenance intervals for engine oil, engine oil filter and water separator for fuel line have been extended to 500 hours, hydraulic oil to 2000 hours for normal applications with S•O•S<sup>SM</sup> analysis monitoring.

**Capsule Filter.** The hydraulic return filters are located in the hydraulic tank. The filter elements are removable without spilling hydraulic oil.

### **Pilot Hydraulic System Filter.**

Pilot hydraulic system filter keeps contaminants from the pilot system and is located in the pump compartment.

### **Radial Seal Main Air Cleaner.**

Radial seal main air cleaner with pre-cleaner has a double-layered filter element for more efficient filtration. No tools are required to change the element.

**Fuel-Water Separator.** The water separator has a primary fuel filter element and is located in the air cleaner compartment for easy access from the ground.

**Service Points.** Service points are centrally located with easy access to facilitate routine maintenance.

### **Oil Sample and Pressure Ports.**

Oil sample and pressure ports provide easy checking of machine condition and are standard on every machine.

**Greasing Points.** A concentrated remote greasing block on the boom delivers grease to hard-to-reach locations.

## Complete Customer Support

*Cat dealer services help you operate longer with lower costs.*



**Machine Selection.** Make detailed comparisons of the machines you are considering before you buy. What are the job requirements, machine attachments and operating hours? What production is needed? Your Cat dealer can provide recommendations.

**Purchase.** Consider the financing options available as well as day-to-day operating costs. This is also the time to look at dealer services that can be included in the cost of the machine to yield lower equipment owning and operating costs over the long run.

### **Customer Support Agreements.**

Cat dealers offer a variety of product support agreements, and work with customers to develop a plan the best meets specific needs. These plans can cover the entire machine, including attachments, to help protect the customer's investment.

**Operation.** Improving operating techniques can boost your profits. Your cat dealer has videotapes, literature and other ideas to help you increase productivity, and Caterpillar offers certified operator training classes to help maximize the return on your investment.

**Product Support.** You will find nearly all parts at our dealer parts counter. Cat dealers utilize a worldwide computer network to find in-stock parts to minimize machine downtime. You can save money with Cat remanufactured components.

**Maintenance Services.** Repair option programs guarantee the cost of repairs up front. Diagnostic programs such as Scheduled Oil Sampling, Coolant Sampling and Technical Analysis help you avoid unscheduled repairs.

**Replacement.** Repair, rebuild or replace? Your Cat dealer can help you evaluate the cost involved so you can make the right choice.

## Booms, Sticks and Linkage

*Designed for flexibility, high productivity, and efficiency in a variety of applications.*

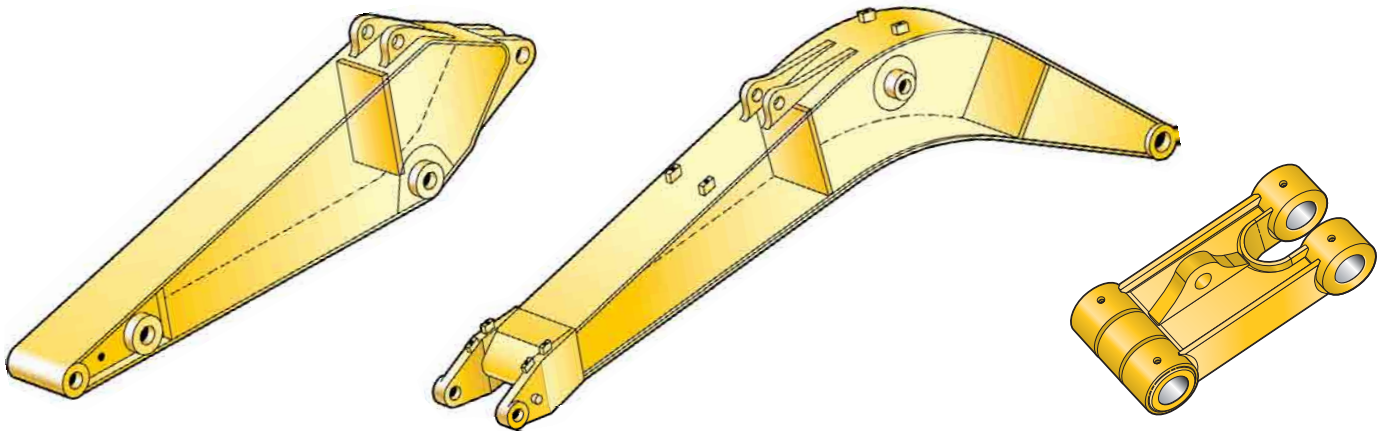

### Front Linkage Attachments.

Select the right combination of front linkage with your Cat dealer to ensure high productivity from the very start of your job. Two types of booms and four sticks are available, offering a range of configurations suitable for a wide variety of applications and offer a large combination of reach and digging forces for optimum versatility. All booms and sticks undergo a stress relieving process for greater durability.

**Boom Construction.** The booms have large cross-sections and internal baffle plates to provide long life durability. Castings and forgings are used in critical high-load areas such as the boom nose, boom foot, and boom cylinder connection.

**Mass Excavation Boom.** The 6.55 m mass boom is designed to provide maximum digging forces, bucket capacity and truck loading productivity. The mass boom comes with two stick options for further job site versatility.

**Reach Boom.** The 6.9 m Reach boom is designed to balance reach, digging force bucket capacity, offering a wide range of applications as digging, loading and trenching.

**Stick Construction.** Sticks are made of high-tensile strength steel using a large box section design with interior baffle plates and an additional bottom guard to protect against damage. The new Quarry Package attachment provides reinforcement bars on the stick.

**Mass Sticks.** Two mass excavation sticks are available for higher digging forces and increased bucket capacity. Mass sticks use UB-family bucket linkage and buckets.

- **M2.5UB.** The 2500 mm stick provides excellent digging envelope with large bucket capacity and high force levels.
- **M3.0UB.** The 3000 mm stick is intended for mass excavation applications with very large buckets with high force requirements.

**Reach Sticks.** Two lengths of reach sticks are available to suite a variety of applications. Reach sticks use the TB-family bucket linkage and buckets.

- **R2.9TB.** The 2900 mm stick has a good digging envelope and handles large bucket sizes.
- **R3.4TB.** The 3350 mm stick offers the most versatility and is suited to all types of applications and bucket capacities.

**Bucket Linkage.** Two bucket linkages are available, with or without a lifting eye on the power link.

- The UB bucket linkage is for use with the mass sticks and UB-family buckets.
- The TB bucket linkage is for use with the reach sticks and TB-family buckets.

**Power Link.** The new power link improves durability, increases machine-lifting capability in key lifting positions, and is easier to use compared to the previous lift bar design. The power link can be equipped with or without the lifting eye.

**Linkage Pins.** All pins used in front linkages have thick chrome plating, giving them high wear and corrosion resistance. The large diameter pins smoothly distribute the shear and bending loads to help ensure long pin, boom and stick life.

## Work Tools and GET

A wide variety of Work Tools help optimize machine performance.

Purpose designed and built to Caterpillar's high durability standards.

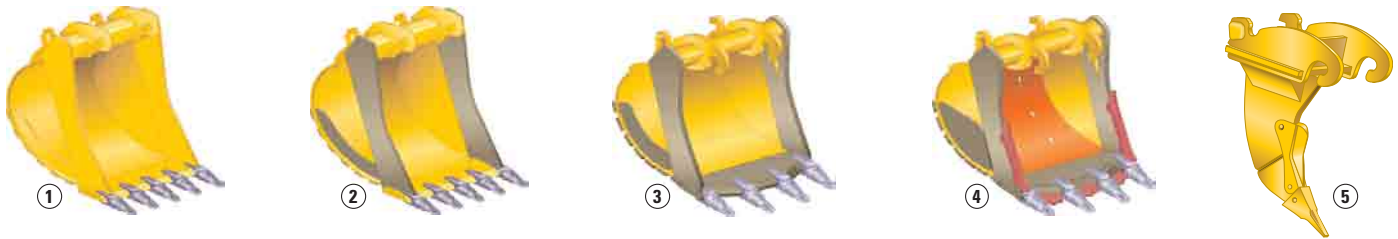

### New Caterpillar K Series™ Tooth System



**Rationalized Bucket Line.** Optimized design matches machine configuration perfectly. Improved balance between performance and durability. Buckets feature the new Caterpillar K Series Tooth System.

- 1 Excavation (X).** Digs and loads soft to medium materials such as clay and earth. Features weld on tip adapters, wear resistant steel alloy cutting edge and wear plates, and high grade steel side bars.
- 2 Extreme Excavation (EX).** Digs and loads compact/abrasive materials like earth/rock, sand/clay, sand/gravel, coal, chalk and low abrasion ores. Features bigger ground engaging tools, plus all wear resistant steel alloy cutting edge, wear plates and side bars.
- 3 Rock (R).** Digs and loads mixed earth/rock soils containing high percentage of rock or other abrasive materials. Features V-spade cutting edge, thicker base and wear surfaces.
- 4 Heavy Duty Rock (HDR).** For aggressive bucket digging and loading in highly abrasive applications such as granite and basalt. Features V-spade cutting edge and extreme wear package.

Differences from rock buckets:

- Highest durability due to extreme wear package;
- Side wear plates are thicker and extend further up to the bucket;
- Inside wear package (liner) made of high strength, 500 Brinell, wear resistant steel alloy;
- Standard equipped with sidebar protectors and edge segments to extend bucket lifetime.

Other buckets and teeth are available from Caterpillar for use in quarry, high abrasion, and special applications. Ask your dealer representative to recommend the optimum solution for your material and operation.

- 5 Ripper.** The Caterpillar TR-series rippers are available for use with CW-series quick couplers, or to attach directly to the stick and linkage. The ripper provides a powerful single point of penetration force to break out rock and other difficult to excavate material. In order to break into the toughest ripping applications a short ripper is available. Usage with the quick coupler and a compatible rock bucket facilitates the "Rip & Load" technique to supplement or replace blasting to prepare rock material prior to truck loading.

**Quick Couplers.** Caterpillar quick couplers enable the operator to simply release one work tool and pick up another. Your hydraulic excavator becomes highly versatile. The dedicated CW-Series quick coupler enables a quick tool exchange while maintaining top machine performance. A lifting hook is added for maximum lift capacity.

**Variety of work tools.** Choose from a variety of work tools such as hammers, crushers, pulverizers, shears, multi-processors and grapples. Ask your Cat dealer for information on attachments or special configurations.

### K Series Tip Selection.

The new Caterpillar K Series Tooth System holds tighter, changes easier and stays sharper.

- 10** General Duty
- 11** Extra Duty
- 12** Penetration
- 13** Penetration Plus
- 14** Heavy Penetration
- 15** Heavy Abrasion
- 16** Wide
- 17** Spike
- 18** Double Spike



# Bucket Specifications

Without Quick Coupler	Linkage	Width	Weight*	Capacity (ISO)	Fill Factor	ME boom 6550 mm		Reach boom 6900 mm	
		mm	kg	m <sup>3</sup>	%	M2.5UB	M3.0UB	R2.9TB	R3.4TB
Excavation (X)	TB	1500	2213	2.2	100	×	×		
	UB	1500	2513	2.8	100			×	×
	UB	1700	2678	3.2	100			×	×
	UB	1900	2878	3.6	100			×	×
Extreme Excavation (EX)	TB	1380	2163	2.0	100	×	×		
	TB	1500	2263	2.2	100	×	×		
	TB	1750	2523	2.8	100	×	×		
	UB	1550	2819	2.8	100			×	×
	UB	1750	3039	3.2	100			×	×
	UB	1850	3112	3.4	100			×	×
Rock (R)	TB	1380	2313	2.0	90	×	×		
	TB	1500	2433	2.2	90	×	×		
	UB	1450	2989	2.6	90			×	×
	UB	1550	3089	2.8	90			×	×
	UB	1700	3259	3.2	90			×	×
	UB	1800	3412	3.4	90			×	×
Heavy Duty Rock (HDR)	UB	1450	3364	2.6	90			×	×
	UB	1550	3489	2.8	90			×	×
Maximum load in kg (payload plus bucket)						8290	7510	7600	7120
<b>With Quick Coupler CW-55</b>									
Excavation (X)	TB	1500	2188	2.2	100	×	×		
Extreme Excavation (EX)	TB	1380	2138	2.0	100	×	×		
	TB	1500	2238	2.2	100	×	×		
	UB	1400	2649	2.4	100			×	×
	UB	1550	2789	2.8	100			×	×
	UB	1750	3014	3.2	100			×	×
Rock (R)	TB	1380	2288	2.0	90	×	×		
	UB	1450	2964	2.6	90			×	×
	UB	1550	3064	2.8	90			×	×
Heavy Duty Rock (HDR)	UB	1450	3339	2.6	90			×	×
Maximum load in kg (payload plus bucket)						7710	6900	7140	6610

\* Bucket weight including K Series Penetration Plus tips



Max. Material Density  
1200 kg/m<sup>3</sup>



Max. Material Density  
1500 kg/m<sup>3</sup>



Max. Material Density  
1800 kg/m<sup>3</sup>



Not compatible

## Work Tools Matching Guide

When choosing between various work tool models that can be installed onto the same machine configuration, consider work tool application, productivity requirements, and durability. Refer to work tool specifications for application recommendations and productivity information.

	Stick length (mm)	Without Quick Coupler				With Quick Coupler CW-55			
		ME boom 6550 mm		Reach boom 6900 mm		ME boom 6550 mm		Reach boom 6900 mm	
		2500	3000	2900	3350	2500	3000	2900	3350
Ripper	TR-55								
Multiprocessor	MP30 CC, CR, PP, PS, S, TS								
	MP40 CC, CR, PS, S		N	N	N	N	N	N	N
Crusher and Pulverizer	VHC-50								
	VHC-60				N		N	N	N
	VHP-50								
	VHP-60		N	N	N	N	N	N	N
Hydraulic Shear	S340							N	N
	S365B*, S385B*					N	N	N	N
Mechanical Grapple	G140								
Demolition and Sorting Grapple	G330								
Hydraulic Hammer	H160D S, H180 S								

\* Boom mounted



360° Working Range



Over the front



Not recommended

## Engine

Cat C13 with ACERT Technology

Net Power at 1800 rpm

ISO 9249	239 kW/325 hp
----------	---------------

EEC 80/1269	239 kW/325 hp
-------------	---------------

Bore	130 mm
------	--------

Stroke	157 mm
--------	--------

Displacement	12.5 liters
--------------	-------------

- All engine horsepower (hp) are metric including front page.
- The C13 engine meets Stage IIIA emission requirements.
- Net power advertised is the power available at the flywheel when the engine is equipped with fan, air cleaner, muffler, and alternator.
- No engine derating required below 2300 m altitude.

## Brakes

Meets the standard ISO 10265:1998

## Sound

### Operator Sound

- The operator sound level measured according to the procedures specified in ISO 6394:1998 is 75 dB(A), for cab offered by Caterpillar, when properly installed and maintained and tested with the doors and windows closed.
- Hearing protection may be needed when operating with an open operator station and cab (when not properly maintained or doors/windows open) for extended periods or in noisy environment.

### Exterior Sound

- The labeled spectator sound power level measured according to the test procedures and conditions specified in 2000/14/EC is 106 dB(A).

## Cab/FOGS

Cab/FOGS meets ISO 10262.

## Hydraulic System

### Main System

Maximum flow	2 x 360 l/min
--------------	---------------

Maximum pressure	
------------------	--

Normal	350 bar
--------	---------

Heavy lift	380 bar
------------	---------

Travel	350 bar
--------	---------

Swing	314 bar
-------	---------

### Pilot System

Maximum flow	43 l/min
--------------	----------

Maximum pressure	41 bar
------------------	--------

### Boom Cylinder

Bore	160 mm
------	--------

Stroke	1575 mm
--------	---------

### Stick Cylinder

Bore	190 mm
------	--------

Stroke for reach front	1778 mm
------------------------	---------

Stroke for ME front	1758 mm
---------------------	---------

### TB Family Bucket Cylinder

Bore	160 mm
------	--------

Stroke	1356 mm
--------	---------

### UB Family Bucket Cylinder

Bore	170 mm
------	--------

Stroke	1396 mm
--------	---------

## Machine and Major Component Weights

Actual weights and ground pressures will depend on final machine configuration.

		ME boom 6550 mm		Reach boom 6900 mm	
		M2.5UB	M3.0UB	R2.9TB	R3.4TB
Stick type					
Stick length	mm	2500	3000	2900	3350
Bucket weight	kg	2900	2900	2200	2100
Bucket capacity	m <sup>3</sup>	2.6	2.6	2.2	2.0
Bucket width/type	mm	1450/R	1450/R	1500/EX	1380/EX
Operating weight*					
with 600 mm shoes	kg	50 420	50 600	49 000	48 800
with 750 mm shoes	kg	51 360	51 540	49 940	49 740
with 900 mm shoes	kg	52 110	52 290	50 690	50 490
Ground pressure	bar	0.89	0.89	0.87	0.86
Stick weight (with bucket cylinder)	kg	2230	2410	2125	2117
Boom weight (with stick cylinder)	kg	4600		4080	
Boom cylinders (pair)	kg	804			
Upperstructure**	kg	12 260			
Undercarriage with 600 mm shoes	kg	17 800			
Counterweight	kg	9040			

\* With counterweight, operator and full fuel.

\*\* Without counterweight.

## Dimensions

All dimensions are approximate.

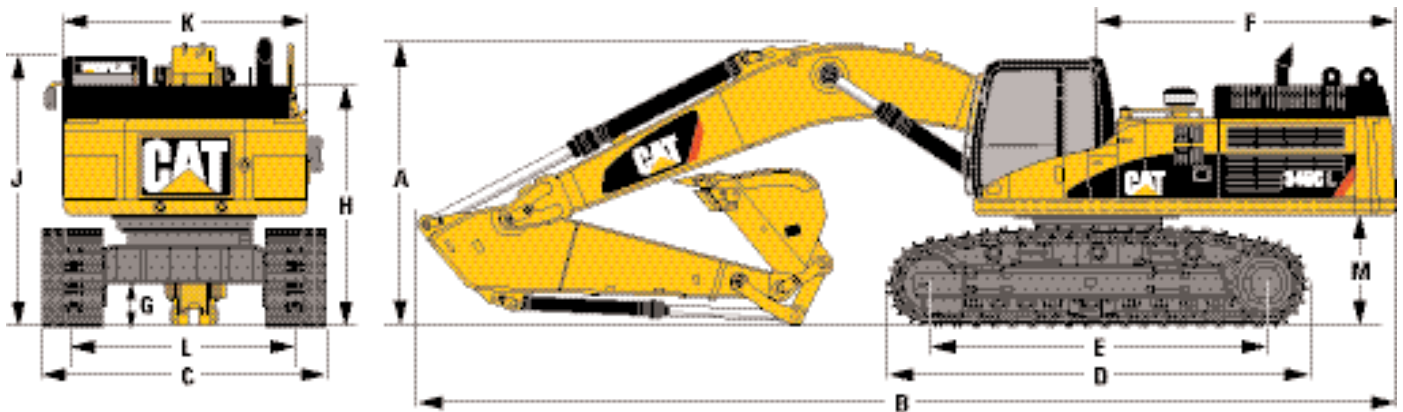

	mm
<b>A</b> Shipping height (with bucket)	
Mass Excavation boom 6550 mm	
2500 mm stick	3989
3000 mm stick	3987
Reach boom 6900 mm	
2900 mm stick	3743
3350 mm stick	3581

	mm
<b>B</b> Shipping length	
Mass Excavation boom 6550 mm	
2500 mm stick	11 591
3000 mm stick	11 507
Reach boom 6900 mm	
2900 mm stick	11 837
3350 mm stick	11 788

	mm
<b>C</b> Track width retracted	
600 mm shoes	2995
750 mm shoes	3140
900 mm shoes	3290
<b>D</b> Track length	5333
<b>E</b> Length to centers of rollers	4338
<b>F</b> Tail swing radius	3765
<b>G</b> Ground clearance	707
<b>H</b> Body height*	2962
<b>J</b> Cab height*	3358
<b>K</b> Body width	2962
<b>L</b> Track gauge	
extended	2890
retracted	2390
<b>M</b> Counterweight clearance	1339

\* With shoe lug height 38 mm

## Track

Track width with long undercarriage:	
Double grouser, heavy duty	
optional	600 mm
optional	750 mm
Triple grouser, heavy duty	
standard	600 mm
optional	750 mm
optional	900 mm
Number of shoes each side	52
Number of rollers each side	9
Number of carrier rollers each side	3

## Drive

Maximum Travel Speed	4.4 km/h
Maximum Drawbar Pull	338 kN

## Swing Mechanism

Swing Speed	8.6 rpm
Swing Torque	149 kNm

## Service Refill Capacities

	Liters
Fuel Tank	705
Cooling System	61
Engine Oil	42
Swing Drive (each)	10
Final Drive (each)	15
Hydraulic system (including tank)	570
Hydraulic tank	243

# Working Ranges

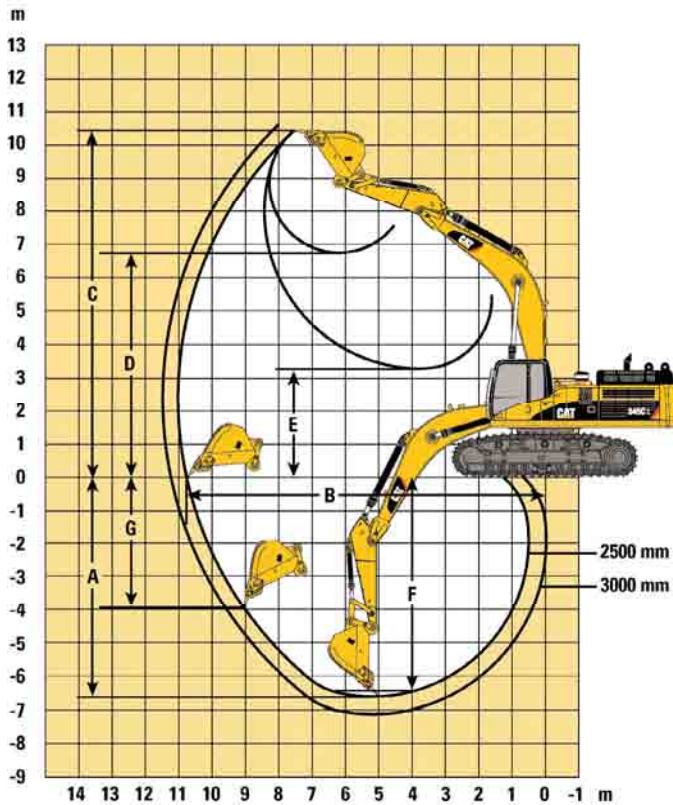

## Mass Excavation (ME) boom configuration (6550 mm)

		M2.5UB	M3.0UB
Stick Length	mm	2500	3000
<b>A</b> Maximum Digging Depth	mm	-6610	-7110
<b>B</b> Maximum Reach at Ground Level	mm	10 756	11 220
<b>C</b> Maximum Cutting Height	mm	10 409	10 601
<b>D</b> Maximum Loading Height	mm	6729	6922
<b>E</b> Minimum Loading Height	mm	3280	2804
<b>F</b> Maximum Digging Depth 2.44 m Level Bottom	mm	-6439	-7026
<b>G</b> Maximum Vertical Wall Digging Depth	mm	-3924	-4362
Bucket Capacity	m <sup>3</sup>	2.6	2.6
Bucket radius at Cutting edge	mm	1936	1936
Bucket digging Force (ISO)	kN	273	258
Stick digging Force (ISO)	kN	258	233

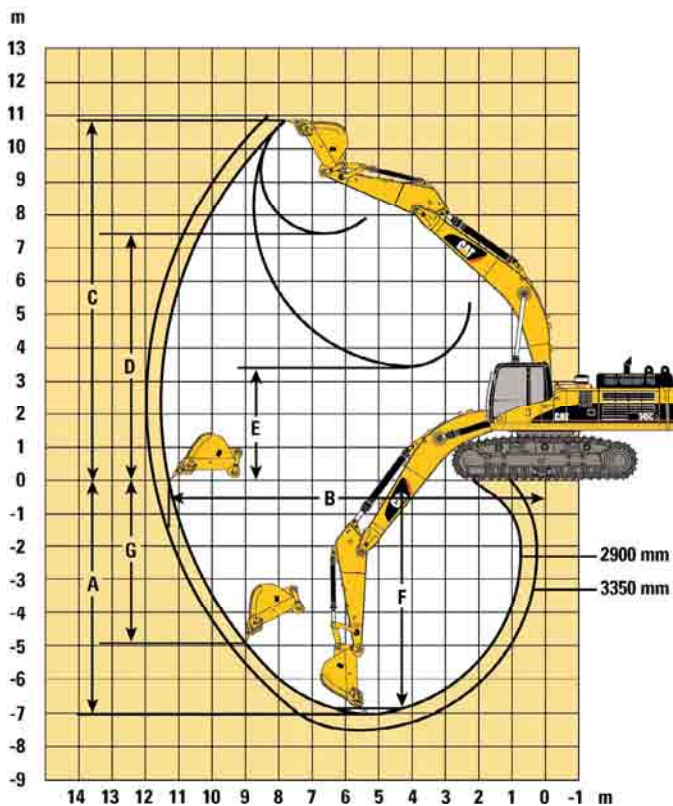

## Reach (R) boom configuration (6900 mm)

		R2.9TB	R3.4TB
Stick Length	mm	2900	3350
<b>A</b> Maximum Digging Depth	mm	-7041	-7491
<b>B</b> Maximum Reach at Ground Level	mm	11 284	11 703
<b>C</b> Maximum Cutting Height	mm	10 826	11 003
<b>D</b> Maximum Loading Height	mm	7403	7580
<b>E</b> Minimum Loading Height	mm	3411	2968
<b>F</b> Maximum Digging Depth 2.44 m Level Bottom	mm	-6879	-7344
<b>G</b> Maximum Vertical Wall Digging Depth	mm	-4888	-5296
Bucket Capacity	m <sup>3</sup>	2.2	2.0
Bucket radius at Cutting edge	mm	1735	1735
Bucket digging Force (ISO)	kN	249	239
Stick digging Force (ISO)	kN	235	217



# Lift Capacities

All weights are in kg. With Heavy Lift on.









## Mass Boom 6550 mm

Short Stick  
2500 mm

Shoes  
600 mm

Bucket Capacity  
2.6 m<sup>3</sup>

Bucket Weight  
2970 kg

	3.0 m		4.5 m		6.0 m		7.5 m		9.0 m		10.5 m		   		m
9.0 m													*5640	*5640	8.28
7.5 m							*9250	*9250					*5370	*5370	9.41
6.0 m							*9620	9350					*5350	5020	10.11
4.5 m			*17 440	*17 440	*12 860	*12 860	*10 470	9030	*9070	6090			*5520	4440	10.48
3.0 m			*21 170	20 050	*14 690	12 660	*11 430	8580	*9470	5940			*5870	4200	10.57
1.5 m			*20 140	18 510	*16 020	11 830	*12 190	8150	*9760	5760			*6440	4250	10.4
0 m			*22 500	18 050	*16 460	11 360	*12 480	7860	*9650	5640			*7310	4630	9.94
-1.5 m	*16 780	*16 780	*21 380	18 130	*15 900	11 220	*12 020	7760					*7540	5510	9.17
-3.0 m	*21 590	*21 590	*18 700	18 570	*14 110	11 400	*10 180	7920							
-4.5 m			*13 990	*13 990	*10 040	*10 040									









## Mass Boom 6550 mm

Medium Stick  
3000 mm

Shoes  
600 mm

Bucket Capacity  
2.6 m<sup>3</sup>

Bucket Weight  
2970 kg

	3.0 m		4.5 m		6.0 m		7.5 m		9.0 m		10.5 m		   		m
9.0 m													*4160	*4160	8.89
7.5 m							*8380	*8380					*3940	*3940	9.94
6.0 m							*8880	*8880	*7000	6240			*3930	*3930	10.59
4.5 m					*11 930	*11 930	*9800	9110	*8520	6160			*4060	3970	10.94
3.0 m			*19 880	*19 880	*13 910	12 830	*10 870	8620	*9040	5950			*4350	3750	11.03
1.5 m			*22 420	18 910	*15 490	11 930	*11 780	8140	*9480	5720			*4810	3780	10.86
0 m	*7890	*7890	*22 970	18 130	*16 260	11 340	*12 280	7790	*9620	5540			*5520	4090	10.43
-1.5 m	*15 700	*15 700	*22 060	18 000	*16 060	11 100	*12 110	7620	*9060	5490			*6640	4800	9.7
-3.0 m	*21 810	*21 810	*19 850	18 280	*14 730	11 170	*10 900	7680							
-4.5 m	*21 140	*21 140	*15 870	*15 870	*11 650	11 560									









## Reach Boom 6900 mm

Short Stick  
2900 mm

Shoes  
600 mm

Bucket Capacity  
2.2 m<sup>3</sup>

Bucket Weight  
2300 kg

	3.0 m		4.5 m		6.0 m		7.5 m		9.0 m		10.5 m		   		m
9.0 m													*4820	*4820	9.07
7.5 m							*9110	*9110					*4640	*4640	10.09
6.0 m							*9700	*9700	*8870	6940			*4630	*4630	10.74
4.5 m			*17 590	*17 590	*13 030	*13 030	*10 680	9580	*9290	6800			*4770	4530	11.09
3.0 m			*21 670	20 510	*15 040	13 110	*11 770	9110	*9840	6580			*5040	4320	11.19
1.5 m			*18 050	*18 050	*16 540	12 330	*12 670	8670	*10 310	6350			*5480	4340	11.05
0 m			*19 250	18 700	*17 170	11 880	*13 130	8370	10 270	6190			*6150	4620	10.65
-1.5 m	*14 790	*14 790	*19 560	18 730	*16 850	11 720	*12 950	8240	*10 050	6140			*7180	5240	9.97
-3.0 m	*18 960	*18 960	*20 360	19 030	*15 510	11 820	*11 840	8310					*6750	*6150	8.93
-4.5 m	*19 520	*19 520	*16 590	*16 590	*12 680	12 180									









## Reach Boom 6900 mm

Medium Stick  
3350 mm

Shoes  
600 mm

Bucket Capacity  
2.0 m<sup>3</sup>

Bucket Weight  
2191 kg

	3.0 m		4.5 m		6.0 m		7.5 m		9.0 m		10.5 m		   		m
9.0 m													*4110	*4110	9.6
7.5 m									*5820	*5820			*3960	*3960	10.55
6.0 m							*9220	*9220	*8480	7160			*3950	*3950	11.17
4.5 m					*12 380	*12 380	*10 270	9800	*9000	6980			*4070	*4070	11.51
3.0 m			*20 650	*20 650	*14 530	13 450	*11 460	9310	*9640	6730			*4310	4110	11.6
1.5 m			*21 390	19 710	*16 270	12 620	*12 490	8850	*10 210	6480			*4700	4120	11.47
0 m	*7540	*7540	*20 100	19 030	*17 190	12 090	*13 130	8510	10 360	6280			*5280	4350	11.09
-1.5 m	*14 070	*14 070	*20 210	18 900	*17 180	11 860	*13 170	8330	10 260	6190			*6160	4880	10.44
-3.0 m	19 000	*19 000	*21 160	19 080	*16 170	11 870	*12 390	8330					*6950	5910	9.46
-4.5 m	*19 700	*19 700	*18 260	*18 260	*13 850	12 130	*10 190	8550							
-6.0 m			*12 600	*12 600	*8950	*8950									



Load Point Height



Load Radius Over Front



Load Radius Over Side



Load at Maximum Reach

\* Limited by hydraulic rather than tipping load.

The above loads are in compliance with hydraulic excavator lift capacity ratings standard ISO/DIS 10567, they do not exceed 87% of hydraulic lifting capacity or 75% of tipping capacity. Weight of all lifting accessories must be deducted from the above lifting capacities.

## Standard Equipment

Standard equipment may vary. Consult your Caterpillar dealer for specifics.

### Electrical

- Alternator – 75 amp
- Lights working
  - Boom, both side
  - Cab interior
  - Cab mounted, two
  - Frame mounted
- Signal/warning horn

### Engine/Power Train

- Automatic engine speed control
- Automatic swing parking brake
- Automatic travel parking brakes
- Caterpillar C13 with ACERT Technology
  - Altitude capability to 2300 m without derating
- Fine swing control
- Fuel Filter
- High ambient cooling, 48°C capability
- Secondary engine shut-off switch
- Side-by-side cooling system with separately mounted AC condenser and variable speed fan
- Two speed travel
- Water separator, with level indicator, for fuel line

### Guards

- Heavy duty bottom guards on upper frame
- Heavy duty swivel guard on undercarriage
- Heavy duty travel motor guards on undercarriage

### Operator Station

- Adjustable armrest
- Air conditioner, heater and defroster with automatic climate control
- Ashtray and 24 volt lighter
- Beverage/cup holder
- Bolt-on FOGS capability
- Capability to install 2 additional pedals
- Coat hook
- Console mounted electronic type joysticks with adjustable gain and response
- Electrical provision for seat heater
- EU sound criteria package
- Floor mat, washable
- Instrument panel and gauges with full color graphical display, start-up level checks
- Laminated front windshield
- Literature compartment
- Mirrors – left and right
- Neutral lever (lock out) for all controls
- Positive filtered ventilation, pressurized cab
- Rear window, emergency exit
- Retractable seat belt 51 mm width
- Sliding upper door window
- Stationary skylight (polycarbonate)
- Storage compartment suitable for a lunch box
- Sunshade for windshield and skylight
- Travel control pedals with removable hand levers
- Windshield wipers and washers (upper and lower)

### Track

- Triple grouser shoes – 600 mm width, heavy duty
- Grease lubricated track
- Hydraulic track adjusters
- Idler and center section track guards

### Undercarriage

- Long, variable gauge
- Steps – four

### Other Standard Equipment

- Auxiliary hydraulic valve for hydro-mechanical tools
- Cat batteries
- Cat branded XT hoses and reusable couplings
- Cat Datalink and capability to use ET
- Caterpillar one key security system with locks for doors, cab and fuel cap
- Cross-roller type swing bearing
- Counterweight 9000 kg with lifting hook
- Drive for auxiliary pump
- Hand control pattern changer
- Heavy lift mode
- Regeneration circuit for boom and stick
- S•O•S<sup>SM</sup> quick sampling valves for engine oil and hydraulic oil
- Steel firewall between engine and hydraulic pumps
- Wiring provisions for Product Link, Auto-lube System and lighted beacon

## Optional Equipment

Optional equipment may vary. Consult your Caterpillar dealer for specifics.

### Front Linkage

Bucket linkages

TB-family for TB sticks (available with or without lifting eye)

UB-family for UB sticks (available with or without lifting eye)

Buckets – see chart pg.13

Booms (with two working lights)

Mass excavation

– 6550 mm

Reach

– 6900 mm

Sticks

For mass boom

– M2.5UB

– M2.5UB quarry reinforced

– M3.0UB

For reach boom

– R2.9TB

– R3.4TB

Tips, sidecutters and edge protectors

### Track

Double grouser, heavy duty

– 600 mm

– 750 mm

Triple grouser, heavy duty

– 750 mm

– 900 mm

### Undercarriage

Fixed gauge

Track length 5370 mm

Gauge 2740 mm

Ground clearance 510 mm

Extreme service

Track length 5850 mm

Gauge

retracted 2250 mm

extended 2750 mm

Ground clearance 840 mm

### Guards

Bucket cylinder quarry

FOGS (Falling Object Guard System) including overhead and windshield guards

Track guiding guards – full length

Wire mesh screen for windshield

### Auxiliary Controls and Lines

Auxiliary boom lines (high pressure for reach and mass booms)

Auxiliary stick lines (high pressure for reach and mass booms)

Basic control arrangements:

– Single action (one way high pressure circuit for hammer application)

– Tool Control

– Combined function (one way high pressure circuit for hammer application, function for 1-way or 2-way high pressure)

– Medium pressure circuit  
– Tool selection (via monitor 5 tools)

– Medium pressure circuit

### Miscellaneous Options

Bio hydraulic oil package

Boom lowering control device with SmartBoom

Cab front rain protector

Converters, 7 amp-12V

– One

– Two

Electric refueling pump with auto shut-off

Fine filtration filter

Jump start terminals

Radiator screen

Reversible cooling fan including protective screen

Starting aid for cold weather with ether

Stick lowering control device

Travel alarm with cut off switch

### Operator Compartment

Joysticks

Four button joystick for standard machine or single action auxiliary control

Thumb wheel modulation joystick for use with combined auxiliary control

Lunch box storage with lid

Machine security system with programmable keys

Radio

AM/FM radio mounted in right hand console with antenna and two speakers

Radio ready mounting at rear location including 24V to 12V converter speakers, antenna

Seat

Adjustable high-back seat with mechanical suspension

Adjustable high-back seat with air suspension

Adjustable high-back heated seat with air suspension

Straight travel pedal

Windshield

1-piece standard duty

1-piece high impact resistant

50-50 split, sliding

70-30 split, sliding

# 345C L Hydraulic Excavator

For more complete information on Cat products, dealer services, and industry solutions, visit us on the web at [www.cat.com](http://www.cat.com)

Materials and specifications are subject to change without notice. Featured machines in photos may include additional equipment. See your Caterpillar dealer for available options.

© 2007 Caterpillar -- All rights reserved

CAT, CATERPILLAR, their respective logos, "Caterpillar Yellow" and the POWER EDGE trade dress as well as corporate and product identity used herein, are trademarks of Caterpillar and may not be used without permission.

HEHH3113-1 (04/2007) hr



## Free Manuals Download Website

<http://myh66.com>

<http://usermanuals.us>

<http://www.somanuals.com>

<http://www.4manuals.cc>

<http://www.manual-lib.com>

<http://www.404manual.com>

<http://www.luxmanual.com>

<http://aubethermostatmanual.com>

Golf course search by state

<http://golfingnear.com>

Email search by domain

<http://emailbydomain.com>

Auto manuals search

<http://auto.somanuals.com>

TV manuals search

<http://tv.somanuals.com>