



# Advanced Series Advanced Series **GT**

## INSTRUCTION MANUAL

C5-S



C8-S



C9.25-S

<b>INTRODUCTION .....</b>	<b>4</b>
Warning .....	4
<b>ASSEMBLY .....</b>	<b>7</b>
Setting up the Tripod .....	7
Attaching the Equatorial Mount .....	8
Attaching the Center Leg Brace .....	8
Installing the Counterweight Bar .....	8
Installing the Counterweight .....	9
Attaching the Hand Control Holder .....	9
Attaching the Slow Motion Knobs .....	9
Attaching the Optical Tube to the Mount .....	10
Attaching the Visual Back .....	10
Installing the Star Diagonal .....	11
Installing the Eyepiece .....	11
Installing the Finderscope .....	11
Removing the Lens Cap .....	12
Moving the Telescope Manually .....	13
Balancing The Mount in R.A. ....	13
Balancing The Mount in DEC .....	14
Adjusting the Mount .....	14
Adjusting the Mount in Altitude .....	14
Adjusting the Mount in Azimuth .....	15
Attaching the Declination Cable (For GT Models Only) .....	15
Powering the Telescope .....	15
<b>HAND CONTROL .....</b>	<b>16</b>
Hand Control Operation .....	17
Alignment Procedures .....	18
Startup Procedure .....	18
Auto Align .....	19
Auto Three-Star Align .....	19
Quick-Align .....	20
Last Alignment .....	20
Re-Alignment .....	20
Object Catalog .....	21
Selecting an Object .....	21
Slewing to an Object .....	21
Finding Planets .....	21
Tour Mode .....	22
Constellation Tour .....	22
Direction Buttons .....	22
Rate Button .....	22
Setup Procedures .....	23
Tracking Mode .....	23
Tracking Rate .....	23
Date/Time .....	23
User Defined Objects .....	23
Get RA/DEC .....	24
Goto R.A/Dec .....	24
Identify .....	24
Precise GoTo .....	25
Scope Setup Features .....	25
Setup Time-Site .....	25
Anti-backlash .....	25
Filter Limits .....	25
Direction Buttons .....	26
Goto Approach .....	26
Autoguide Rates .....	26
Azimuth Limits .....	26
East/West Filtering .....	27
Utility Features .....	27
Calibrate Goto .....	27
Home Position .....	27
Polar Align .....	27
Light Control .....	28
Factory Settings .....	28
Version .....	28

Get Alt-Az .....	28
Goto Alt-Az .....	28
Hibernate.....	28
Turn On/Off GPS.....	28
<b>TELESCOPE BASICS.....</b>	<b>30</b>
Image Orientation .....	30
Focusing.....	31
Aligning the Finderscope .....	31
Calculating Magnification.....	31
Determining Field of View.....	32
General Observing Hints.....	32
<b>ASTRONOMY BASICS.....</b>	<b>33</b>
The Celestial Coordinate System .....	33
Motion of the Stars.....	34
Finding the North Celestial Pole .....	36
Declination Drift Method of Polar Alignment.....	37
<b>CELESTIAL OBSERVING.....</b>	<b>38</b>
Observing the Moon.....	38
Lunar Observing Hints.....	38
Observing the Planets.....	38
Observing the Sun.....	38
Solar Observing Hints.....	39
Observing Deep Sky Objects .....	39
Seeing Conditions .....	39
Transparency.....	39
Sky Illumination.....	39
Seeing .....	39
<b>ASTROPHOTOGRAPHY .....</b>	<b>41</b>
Short Exposure Prime Focus Photography .....	41
Eyepiece Projection.....	42
Long Exposure Prime Focus Photography .....	43
Terrestrial Photography.....	45
Metering.....	45
Reducing Vibration .....	45
CCD Imaging.....	45
Auto Guiding .....	46
<b>TELESCOPE MAINTENANCE .....</b>	<b>47</b>
Care and Cleaning of the Optics.....	47
Collimation .....	47
<b>OPTIONAL ACCESSORIES.....</b>	<b>49</b>
<b>APPENDIX A - TECHNICAL SPECIFICATIONS .....</b>	<b>52</b>
<b>APPENDIX B - GLOSSARY OF TERMS .....</b>	<b>53</b>
<b>APPENDIX C - LONGITUDES AND LATITUDES .....</b>	<b>56</b>
<b>APPENDIX D - RS-232 CONNECTION.....</b>	<b>61</b>
<b>APPENDIX E - TIME ZONE MAP .....</b>	<b>63</b>
<b>SKY MAPS.....</b>	<b>65</b>

# **Introduction**

Congratulations on your purchase of the Celestron Advanced Series telescope (AST)! The Advanced Series of telescopes come in standard (non-computerized) and computerized GT models. The Advanced Series is made of the highest quality materials to ensure stability and durability. All this adds up to a telescope that gives you a lifetime of pleasure with a minimal amount of maintenance. Furthermore, your Celestron telescope is versatile — it will grow as your interest grows.

The Advanced GT Series ushers in the next generation of computer automated telescopes. The Celestron Advanced GT series continues in this proud tradition combining large aperture optics with the sophistication and ease of use of our computerized GoTo mount.

If you are new to astronomy, you may wish to start off by using the built-in Sky Tour feature, which commands the telescopes to find the most interesting objects in the sky and automatically slews to each one. Or if you are an experienced amateur, you will appreciate the comprehensive database of over 40,000 objects, including customized lists of all the best deep-sky objects, bright double stars and variable stars. No matter at what level you are starting out, the Advanced Series telescopes will unfold for you and your friends all the wonders of the Universe.

Some of the many standard features of the Advanced GT include:

- Fully enclosed optical encoders for position location.
- Ergonomically designed mount that disassembles into compact and portable pieces.
- Database filter limits for creating custom object lists.
- Storage for programmable user defined objects; and

Many other high performance features!

The AST's deluxe features combine with Celestron's legendary Schmidt-Cassegrain optical system to give amateur astronomers the most sophisticated and easy to use telescopes available on the market today.

Take time to read through this manual before embarking on your journey through the Universe. It may take a few observing sessions to become familiar with your telescope, so you should keep this manual handy until you have fully mastered your telescope's operation. The Advanced GT hand control has built-in instructions to guide you through all the alignment procedures needed to have the telescope up and running in minutes. Use this manual in conjunction with the on-screen instructions provided by the hand control. The manual gives detailed information regarding each step as well as needed reference material and helpful hints guaranteed to make your observing experience as simple and pleasurable as possible.

Your telescope is designed to give you years of fun and rewarding observations. However, there are a few things to consider before using your telescope that will ensure your safety and protect your equipment.

## **Warning**



- ❑ **Never look directly at the sun with the naked eye or with a telescope (unless you have the proper solar filter). Permanent and irreversible eye damage may result.**
- ❑ Never use your telescope to project an image of the sun onto any surface. Internal heat build-up can damage the telescope and any accessories attached to it.
- ❑ Never use an eyepiece solar filter or a Herschel wedge. Internal heat build-up inside the telescope can cause these devices to crack or break, allowing unfiltered sunlight to pass through to the eye.

Never leave the telescope unsupervised, either when children are present or adults who may not be familiar with the correct operating procedures of your telescope.

**Figure 2.1 – Advanced Series  
(Advanced C8-S Shown)**

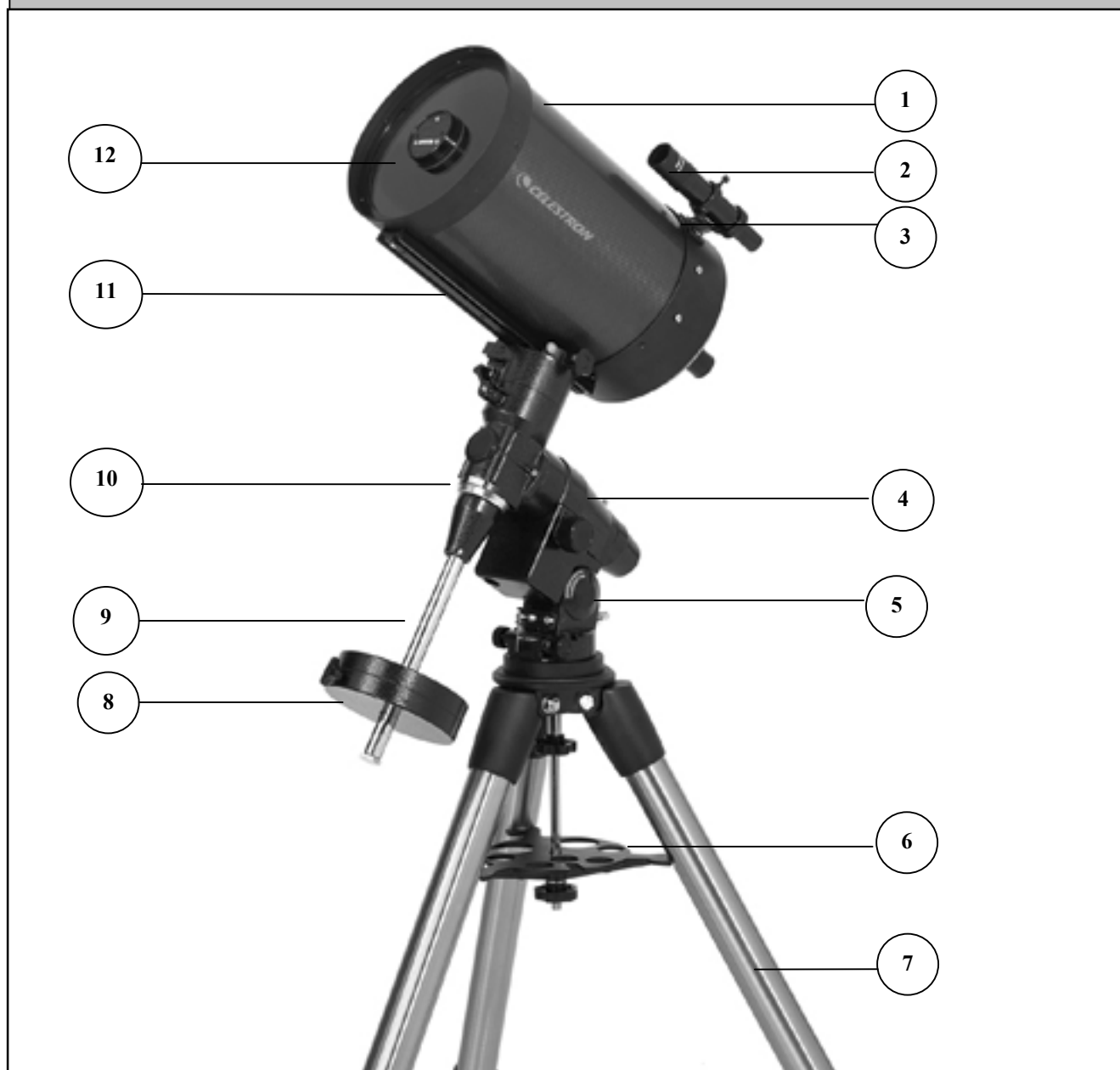

1	Optical Tube	7	Tripod
2	Finderscope	8	Counterweight(s)
3	Finderscope Bracket	9	Counterweight Bar
4	Equatorial Mount	10	Declination Setting Circle
5	Latitude Adjustment Scale	11	Dovetail Mounting Bar
6	Tripod Center Leg Brace/Accessory Tray	12	Schmidt Corrector Lens

**Figure 2.2 – Advanced Series GT  
(Advanced C8-SGT Shown)**

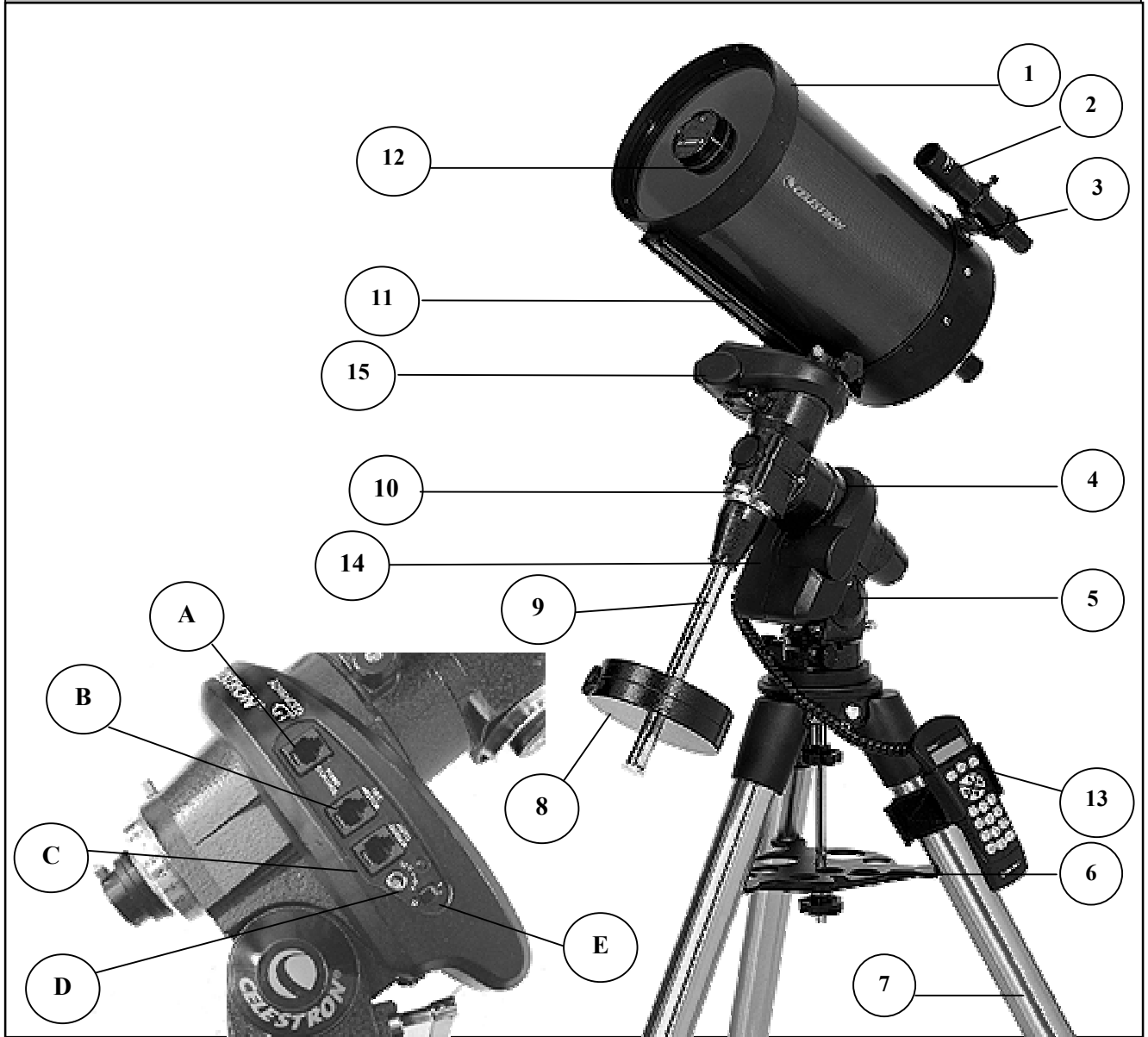

1	Optical Tube	9	Counterweight Bar
2	Finderscope	10	Declination Setting Circle
3	Finderscope Bracket	11	Dovetail Mounting Bar
4	Equatorial Mount	12	Schmidt Corrector Lens
5	Latitude Adjustment Scale	13	Hand Control
6	Tripod Center Leg Brace/Accessory Tray	14	R.A. Motor Drive / Control Panel
7	Tripod	15	Declination Motor Drive
8	Counterweight(s)		
	CONTROL PANEL	C	Autoguider Port
A	Hand Control Port	D	12v Input Jack
B	DEC Motor Port	E	On/Off Switch



This section covers the assembly instructions for your Celestron Advanced Series Telescope (AST). Your AST telescope should be set up indoors the first time so that it is easy to identify the various parts and familiarize yourself with the correct assembly procedure before attempting it outdoors.

	#11071 / 11072	#11025 / 11026	#11045 / 11046
	C5-S	C8-S	C9.25-S
<b>Diameter</b>	127mm (5") Schmidt-Cassegrain	203mm (8") Schmidt-Cassegrain	235mm (9.25") Schmidt-Cassegrain
<b>Focal Length</b>	1250mm F/10	2032mm F/10	2350mm F/10
<b>Eyepiece</b>	25mm - 1.25" (50x)	25mm - 1.25" (81x)	25mm - 1.25" (94x)
<b>Finderscope</b>	6x30	6x30	6x30
<b>Diagonal</b>	90° - 1.25"	90° - 1.25"	90° - 1.25"
<b>Mount</b>	CG-5 Equatorial	CG-5 Equatorial	CG-5 Equatorial
<b>Tripod</b>	2" Stainless Steel	2" Stainless Steel	2" Stainless Steel
<b>Software</b>	The Sky L1	The Sky L1	The Sky L1
<b>Counterweights</b>	1-11lb	1-11lb	2-11lb

The Celestron Advanced Series telescopes are shipped in two boxes (three boxes for GT models). In separate boxes are the following:

- Optical Tube Assembly and Standard Accessories
- Equatorial Mount, Tripod, Hand Control, Counterweight(s) and Counterweight Bar (equatorial mount with motors comes in separate box for GT models)

Remove all the pieces from their respective boxes and place on a flat, clear work area. A large floor space is ideal. When setting up your Celestron telescope you must start with the tripod and work up from there. These instructions are laid out in the order each task must be performed.

## Setting up the Tripod

The CG-5 tripod comes with an all metal center leg brace / accessory tray to give rock solid support to the mount. The tripod comes fully assembled with a metal plate, called the tripod head, that holds the legs together at the top. In addition, there is a central rod that extends down from the tripod head that attaches the equatorial mount to the tripod. To set up the tripod:

1. Stand the tripod upright and pull the tripod legs apart until each leg is fully extended. The tripod will now stand by itself. Once the tripod is set up, you can adjust the height at which it stands.
2. Loosen the lever on the leg clamp so that the tripod leg can be adjusted.
3. Slide the center portion of the tripod leg away from the tripod head until it is at the desired height.
4. Tighten the levers on each leg clamp to hold the legs in place.

## Attaching the Equatorial Mount

The equatorial mount allows you to tilt the telescope's axis of rotation so that you can track the stars as they move across the sky. The CG-5 mount is a German equatorial mount that attaches to the tripod head. On one side of the tripod head there is a metal alignment peg for aligning the mount. This side of the tripod will face north when setting up for an astronomical observing session. To attach the equatorial head:

1. Locate the azimuth adjustment screws on the equatorial mount.
2. Retract the screws so they no longer extend into the azimuth housing on the mount. **Do NOT remove the screws since they are needed later for polar alignment.**
3. Hold the equatorial mount over the tripod head so that the azimuth housing is above the metal peg.
4. Place the equatorial mount on the tripod head so that the two are flush.
5. Tighten the knob (attached to the central rod) on the underside of the tripod head to hold the equatorial mount firmly in place.

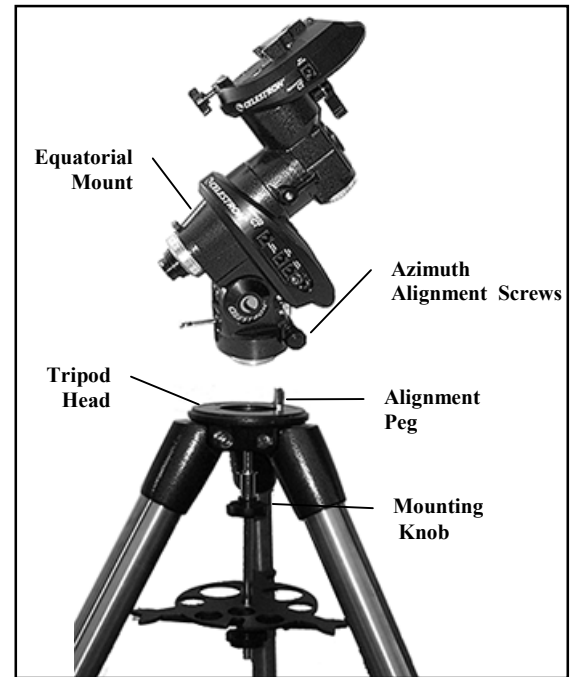

Figure 2-3

## Attaching the Center Leg Brace

1. Slide the accessory tray over the central rod so that each arm of the tray is pushing against the inside of the tripod legs.
2. Thread the accessory tray knob on to the central rod and tighten.

## Installing the Counterweight Bar

To properly balance the telescope, the mount comes with a counterweight bar and at least one counterweight (depending on model). To install the counterweight bar:

1. Locate the opening in the equatorial mount on the DEC axis
2. Thread the counterweight bar into the opening until tight.
3. Tighten the counterweight bar lock nut fully for added support.

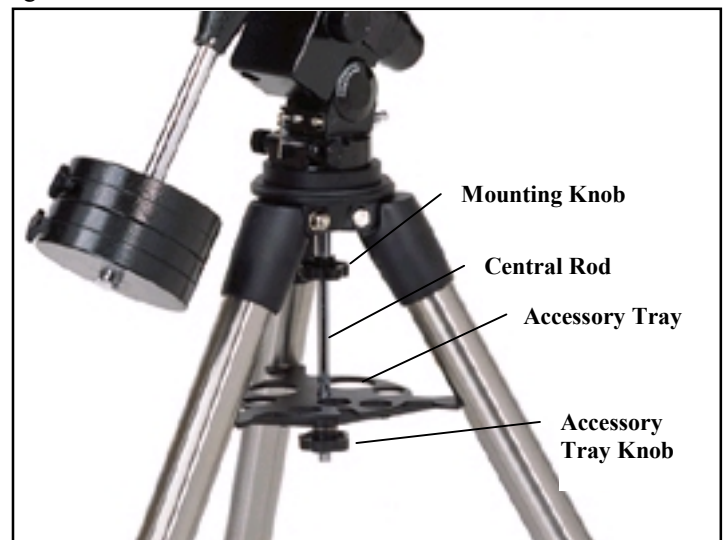

Figure 2-4

Once the bar is securely in place you are ready to attach the counterweight.

**Since the fully assembled telescope can be quite heavy, position the mount so that the polar axis is pointing towards north before the tube assembly and counterweights are attached. This will make the polar alignment procedure much easier.**



## Installing the Counterweight

Depending on which AST telescope you have, you will receive either one or two counterweights. To install the counterweight(s):

1. Orient the mount so that the counterweight bar points toward the ground .
2. Remove the counterweight safety screw on the end of the counterweight bar (i.e., opposite the end that attaches to the mount).
3. Loosen the locking screw on the side of the counterweight.
4. Slide the counterweight onto the shaft (see Figure 2-5).
5. Tighten the locking screw on the side of the weight to hold the counterweight in place.
6. Replace the counterweight safety screw.

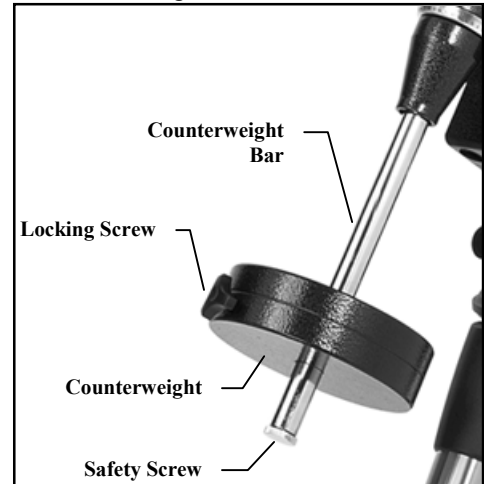

Figure 2-5

## Attaching the Hand Control Holder (Advanced GT Models Only)

The Advanced GT telescope models come with a hand control holder to place the computerized hand control. The hand control holder comes in two pieces: the leg clamp that snaps around the tripod leg and the holder which attaches to the leg clamp. To attach the hand control holder:

1. Place the leg clamp up against one of the tripod legs and press firmly until the clamp wraps around the leg.
2. Slide the back of the hand control holder downward into the channel on the front of the legs clamp (see Fig 2-6) until it snaps into place.

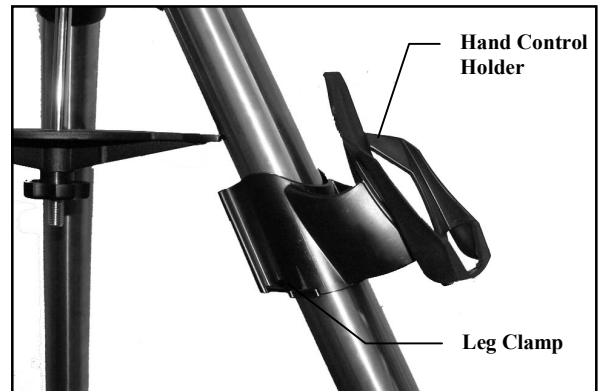

Figure 2-6

## Attaching the Slow Motion Knobs (For Non-GT Models Only)

The Advanced Series (non-GT models) comes with two slow motion control knobs that allows you to make fine pointing adjustments to the telescope in both R.A. and Declination. To install the knobs:

1. Locate the hard plastic shell under the R.A. shafts.
2. Remove either of the two oval tabs by pulling tightly.
3. Line up the flat area on the inner portion of the R.A. slow motion knob with the flat area on the R.A. shaft (see Fig 2-7).
4. Slide the R.A. slow motion knob onto the R.A. shaft.

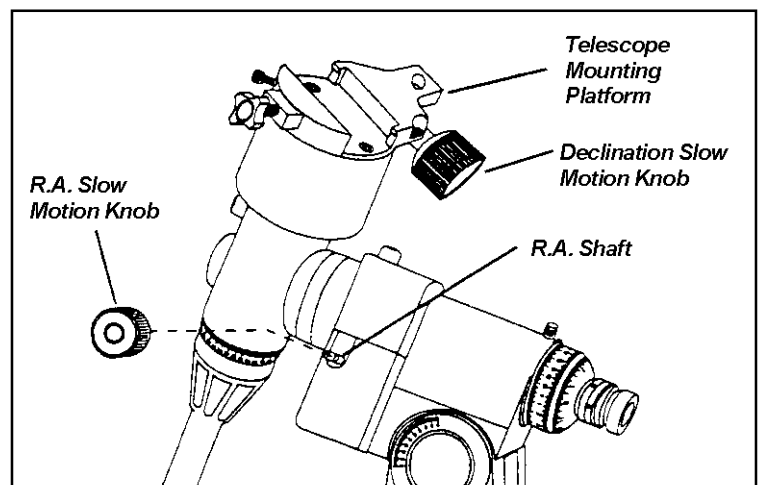

Figure 2-7

The knob is a tension fit, so sliding it on holds it in place. As mentioned above, there are two R.A. shafts, one on either side of the mount. It makes no difference which shaft you use since both work the same. Use whichever one you find more convenient. If, after a few observing sessions, you find the R.A. slow motion knob is more accessible from the other side, pull firmly to remove the knob, then install it on the opposite side.

5. The DEC slow motion knob attaches in the same manner as the R.A. knob. The shaft that the DEC slow motion knob fits over is toward the top of the mount, just below the telescope mounting platform. Once again, you have two shafts to choose from. Use the shaft that is pointing toward the ground. This makes it easy to reach while looking through the telescope, something which is quite important when you are observing.

## Attaching the Optical Tube to the Mount

Advanced  
GT Users!

The telescope attaches to the mount via a dovetail slide bar which is mounted along the bottom of the telescope tube. **Before you attach the optical tube, make sure that the declination and right ascension clutch knobs are tight.** This will ensure that the mount does not move suddenly while attaching the telescope. To mount the telescope tube:

*In order for the GT computerized mount to function properly, before installing the optical tube, the mounting platform must be positioned so that the Declination Index Marks are aligned (see Fig 2-8).*

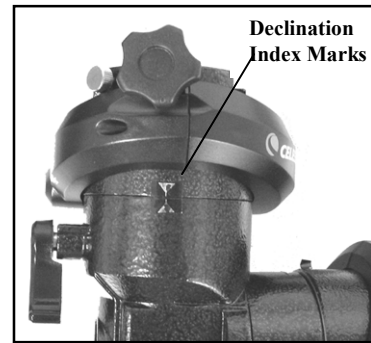

Figure 2-8

1. Loosen the mounting screw on the side of the telescope mounting platform. This allows you to slide the dovetail bar onto the mount.
2. Slide the dovetail bar on the telescope tube into the mounting platform of the mount. Slide the telescope so that the back of the dovetail bar is close to the back of the mounting platform.
3. Tighten the mounting screw on the side of the mounting platform to hold the telescope in place.

Now that the optical tube is securely in place, the visual accessories can now be attached to the telescope.

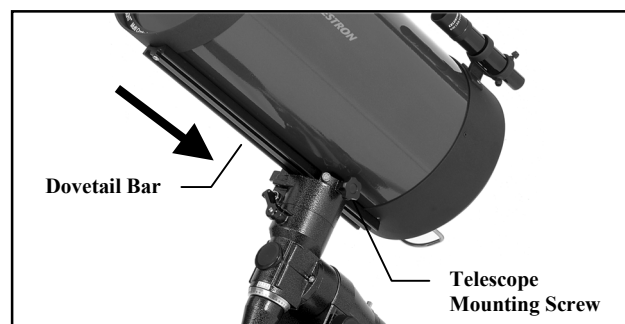

Figure 2-9

## Attaching the Visual Back

The visual back is the accessory that allows you to attach all visual accessories to the telescope. The Advanced Series optical tubes come with the visual back installed. If it is not already on the tube it can be attached as follows:

1. Remove the rubber cover on the rear cell.
2. Place the knurled slip ring on the visual back over the threads on the rear cell (Fig 2-10).

3. Hold the visual back with the set screw in a convenient position and rotate the knurled slip ring clockwise until tight.

Once this is done, you are ready to attach other accessories, such as eyepieces, diagonal prisms, etc.

If you want to remove the visual back, rotate the slip ring counterclockwise until it is free of the rear cell.

## ***Installing the Star Diagonal***

The star diagonal is a prism that diverts the light at a right angle to the light path of the telescope. This allows you to observe in positions that are physically more comfortable than if you looked straight through. To attach the star diagonal onto the optical tube:

1. Turn the set screw on the visual back until its tip no longer extends into (i.e., obstructs) the inner diameter of the visual back.
2. Slide the chrome portion of the star diagonal into the visual back.
3. Tighten the set screw on the visual back to hold the star diagonal in place.

If you wish to change the orientation of the star diagonal, loosen the set screw on the visual back until the star diagonal rotates freely. Rotate the diagonal to the desired position and tighten the set screw.

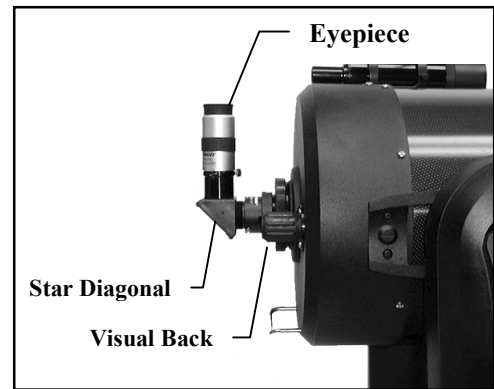

**Figure 2-10**

## ***Installing the Eyepiece***

The eyepiece, or ocular, is an optical element that magnifies the image focused by the telescope. The eyepiece fits into either the visual back directly or the star diagonal. To install an eyepiece:

1. Loosen the set screw on the star diagonal until the tip no longer extends into the inner diameter of the eyepiece end of the diagonal.
2. Slide the chrome portion of the eyepiece into the star diagonal.
3. Tighten the set screw on the star diagonal to hold the eyepiece in place.

To remove the eyepiece, loosen the set screw on the star diagonal and slide the eyepiece out. You can replace it with another eyepiece (purchased separately).

Eyepieces are commonly referred to by focal length and barrel diameter. The focal length of each eyepiece is printed on the eyepiece barrel. The longer the focal length (i.e., the larger the number) the lower the eyepiece power and the shorter the focal length (i.e., the smaller the number) the higher the magnification. Generally, you will use low-to-moderate power when viewing. For more information on how to determine power, see the section on “Calculating Magnification.”

## ***Installing the Finderscope***

The AST telescopes come with a 6x30 finderscope used to help you locate and center objects in the main field of your telescope. To accomplish this, the finder has a built-in cross-hair reticle that shows the optical center of the finderscope.

Start by removing the finder and hardware from the plastic wrapper. Included are the following:

- Finderscope
- Finder Bracket
- Rubber O-ring
- Three Nylon Tipped Thumbscrews (10-24x1/2")
- Two Phillips Head Screws (8-32x1/2")

To install the finderscope:

1. Attach the bracket to the optical tube. To do this, place the curved portion of the bracket with the slot over the two holes in the rear cell. The bracket should be oriented so that the rings that hold the finder are over the telescope tube, not the rear cell (see Fig 2-11). Start threading the screws in by hand and tighten fully with an Allen wrench.
2. Partially thread-in the three nylon-tipped thumbscrews that hold the finder in place inside the bracket. Tighten the screws until the nylon heads are flush with the inner diameter of the bracket ring. Do NOT thread them in completely or they will interfere with the placement of the finder. (Having the screws in place when the finder is installed will be easier than trying to insert the screws after the finder has been installed.)

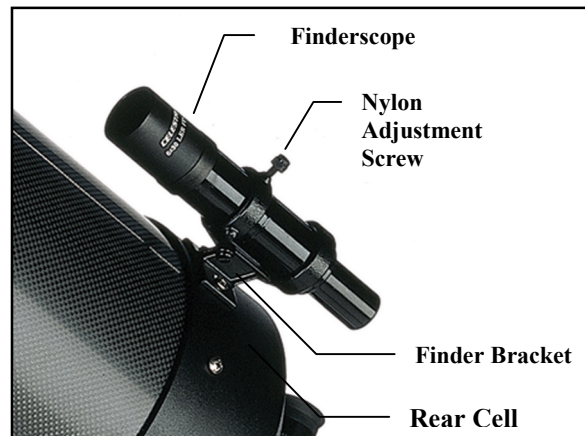

Figure 2-11

3. Slide the rubber O-ring over the back of the finder (it will NOT fit over the objective end of the finder). It may need to be stretched a little. Once on the main body of the finder, slide it up about one inch from the end of the finder.
4. Rotate the finder until one cross hair is parallel to the R.A. axis and the other is parallel to the DEC axis.
5. Slide the eyepiece end of the finder into the front of the bracket.
6. Slightly tighten the three nylon tipped thumbscrews on the front ring of the bracket to hold the finder in place.
7. Once on, push the finder back until the O-ring is snug inside the back ring of the finder bracket.
8. Hand tighten the three nylon tipped thumbscrews until snug.

## **Removing the Lens Cap**

The C5-S and C9.25-S have aluminum lens caps that slide on and off of the front of the telescope. The C8-S lens cap utilizes a bayonet-type locking mechanism to hold it in place. To remove the lens cap, hold the cover firmly and rotate the outer edge 1/2" counterclockwise and pull off.

## Moving the Telescope Manually

In order to properly balance your telescope, you will need to move your telescope manually at various portions of the sky to observe different objects. To make rough adjustments, loosen the R.A. and DEC clutch knobs slightly and move the telescope in the desired direction.

Both the R.A. and DEC axis have lock levers to clutch down each axis of the telescope. To loosen the clutches on the telescope, rotate the lock levers counterclockwise.

## Balancing The Mount in R.A.

To eliminate undue stress on the mount, the telescope should be properly balanced around the polar axis. Proper balancing is crucial for accurate tracking. To balance the mount:

1. Verify that the telescope is securely attached to the telescope mounting platform.
2. Loosen the R.A. lock lever and position the telescope off to one side of the mount. The counterweight bar will extend horizontally on the opposite side of the mount.
3. Release the telescope — GRADUALLY — to see which way the telescope “rolls.”
4. Loosen the set screws on the side of the counterweight so it can be moved the length of the counterweight bar.
5. Move the counterweight to a point where it balances the telescope (i.e., the telescope remains stationary when the R.A. clutch knobs are loose).
6. Tighten the screw on the counterweight to hold it in place.

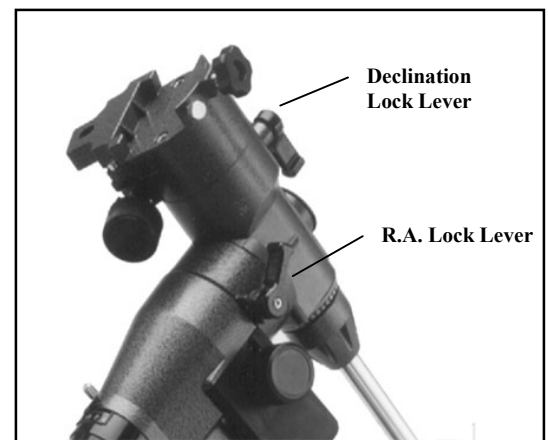

Figure 2-12

While the above instructions describe a perfect balance arrangement, there should be a SLIGHT imbalance to ensure the best possible tracking. When the scope is on the west side of the mount the counterweight should be slightly imbalanced to the counterweight bar side. And when the tube is on the east side of the mount there should be a slight imbalance toward the telescope side. This is done so that the worm gear is pushing against a slight load. The amount of the imbalance is very slight. When taking astrophotographs, this balance process can be done for the specific area at which the telescope is pointing to further optimize tracking accuracy.

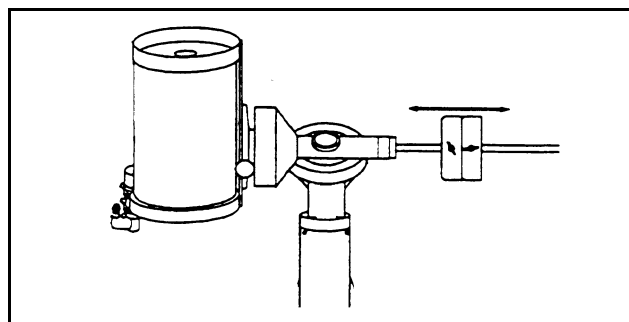

Figure 2-13

## Balancing The Mount in DEC

Although the telescope does not track in declination, the telescope should also be balanced in this axis to prevent any sudden motions when the DEC lock lever is loose. To balance the telescope in DEC:

1. Loosen the R.A. clutch lock lever and rotate the telescope so that it is on one side of the mount (i.e., as described in the previous section on “Balancing the Mount in R.A.”).
2. Tighten the R.A. lock lever to hold the telescope in place.
3. Loosen the DEC clutch lock lever and rotate the telescope until the tube is parallel to the ground.
4. Release the tube — **GRADUALLY** — to see which way it rotates around the declination axis. **DO NOT LET GO OF THE TELESCOPE TUBE COMPLETELY!**
5. Slightly loosen the knobs that holds the telescope to the mounting platform and slide the telescope either forward or backward until it remains stationary when the DEC clutch is loose. Do NOT let go of the telescope tube while the knob on the mounting platform is loose. It may be necessary to rotate the telescope so that the counterweight bar is pointing down before loosening the mounting platform screw.
6. Tighten the knobs on the telescope mounting platform to hold the telescope in place.

Like R.A. balance, these are general balance instructions and will reduce undue stress on the mount. When taking astrophotographs, this balance process should be done for the specific area at which the telescope is pointing.

## Adjusting the Mount

In order for a motor drive to track accurately, the telescope’s axis of rotation must be parallel to the Earth’s axis of rotation, a process known as polar alignment. Polar alignment is achieved NOT by moving the telescope in R.A. or DEC, but by adjusting the mount vertically, which is called altitude, and horizontally, which is called azimuth. This section simply covers the correct movement of the telescope during the polar alignment process. The actual process of polar alignment, that is making the telescope’s axis of rotation parallel to the Earth’s, is described later in this manual in the section on “Polar Alignment.”

### Adjusting the Mount in Altitude

- To increase the latitude of the polar axis, tighten the rear latitude adjustment screw and loosen the front screw (if necessary).
- To decrease the latitude of the polar axis, tighten the front (under the counterweight bar) latitude adjustment screw and loosen the rear screw (if necessary).

The latitude adjustment on the CG-5 mount has a range from approximately 30° going up to 60°.

It is best to always make final adjustments in altitude by moving the mount against gravity (i.e. using the rear latitude adjustment screw to raise the mount). To do this you should loosen both latitude adjustment screws and manually push the front of the mount down as far as it will go. Then tighten the rear adjustment screw to raise the mount to the desired latitude.

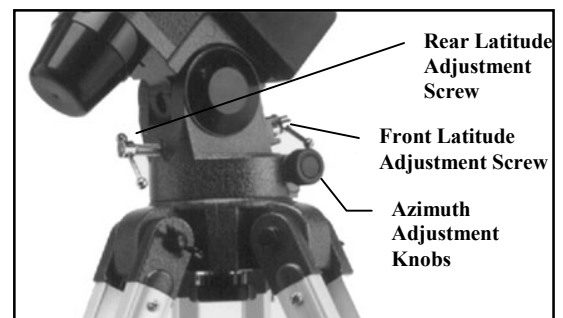

Figure 2-14

For Advanced GT users, it may be helpful to remove the front latitude adjustment screw completely. This will allow the mount to reach lower latitudes without the screw coming into contact with the R.A. motor assembly. To remove the latitude screw, first use the rear screw to raise the mount head all the way up. Then remove the front latitude screw completely. Now you should be able to manually move the mount head all the way to its lowest latitude. Now, using only the rear screw, raise the mount to your desired latitude.

## Adjusting the Mount in Azimuth

For rough adjustments in azimuth, simply pick up the telescope and tripod and move it. For fine adjustments in azimuth:

1. Turn the azimuth adjustment knobs located on either side of the azimuth housing (see Fig 2-14). While standing behind the telescope, the knobs are on the front of the mount.
  - Turning the right adjustment knob clockwise moves the mount toward the right.
  - Turning the left adjustment knob clockwise moves the mount to the left.

Both screws push off of the peg on the tripod head, which means you may have to loosen one screw while tightening the other. The screw that holds the equatorial mount to the tripod may have to be loosened slightly.

Keep in mind that adjusting the mount is done during the polar alignment process only. Once polar aligned, the mount must NOT be moved. Pointing the telescope is done by moving the mount in right ascension and declination, as described earlier in this manual.

## Attaching the Declination Cable (For GT Models Only)

The Advanced Series mount comes with a declination cable that connects from the R.A. motor drive electronic panel to the Dec motor drive. To attach the motor cable:

- Locate the Declination cable and plug one end of the cable into the port on the electronics panel labeled *DEC Port* and plug the other end of the cable into the port located on the declination motor drive (see Fig 2-15).

## Powering the Telescope

The Advanced GT can be powered by the supplied car battery adapter or optional 12v AC adapter. Use only adapters supplied by Celestron. Using any other adapter may damage the electronics or cause the telescope not to operate properly, and will void your manufacturer's warranty.

1. To power the telescope with the car battery adapter (or 12v AC adapter), simply plug the round post into the 12v outlet on the electronic panel and plug the other end into your cars cigarette lighter outlet or portable power supply (see *Optional Accessories*). Note: to prevent the power cord from being accidentally pulled out, wrap the power cord around the strain relief located below the power switch.
2. Turn on the power to the telescope by flipping the switch, located on the electronics panel, to the "On" position.

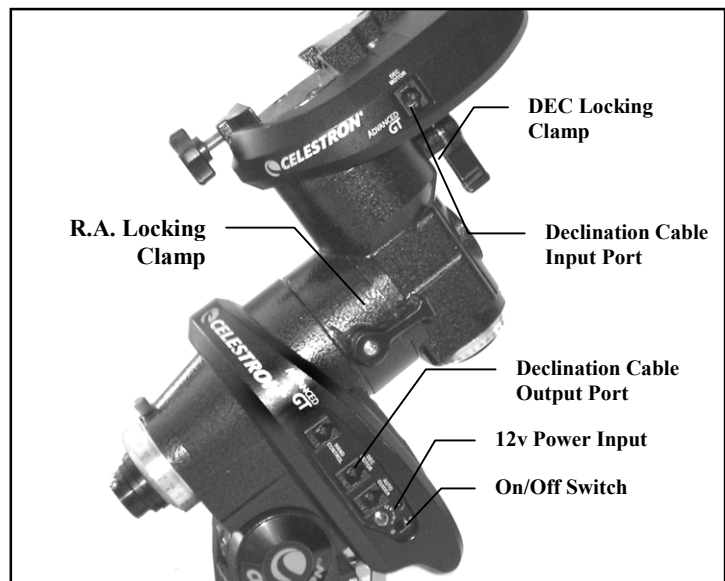
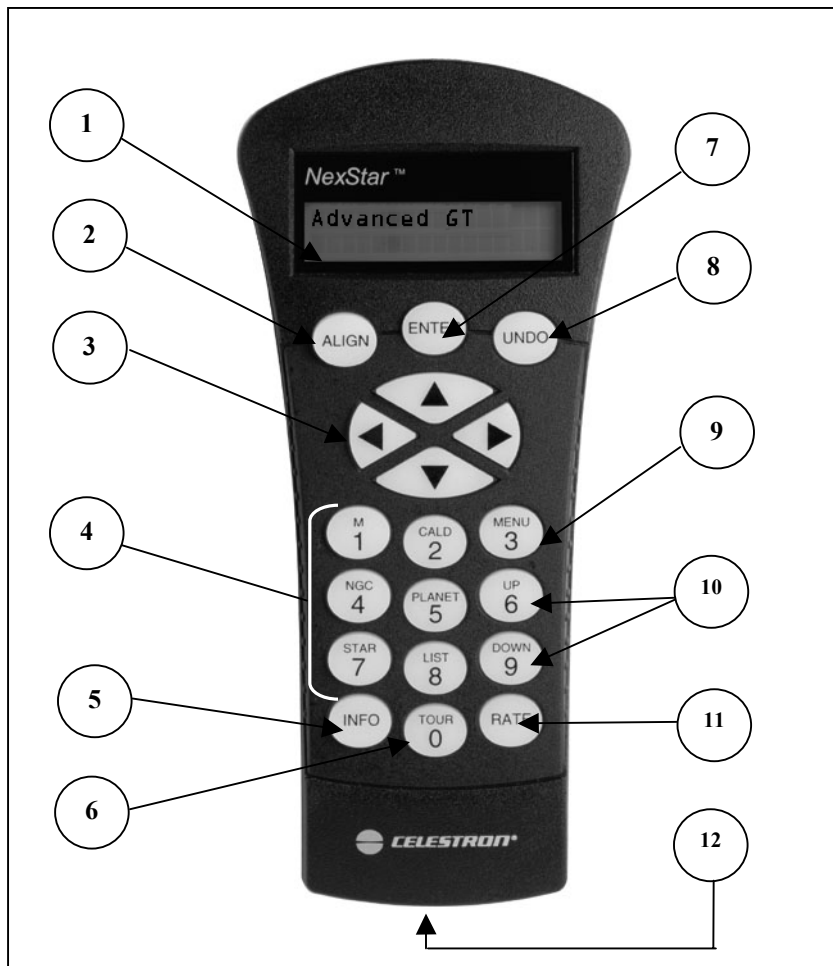

Figure 2-15

# CELESTRON<sup>®</sup> Hand Control

The Advanced Series GT, computerized version of each telescope has a hand controller designed to give you instant access to all the functions that your telescope has to offer. With automatic slewing to over 40,000 objects, and common sense menu descriptions, even a beginner can master its variety of features in just a few observing sessions. Below is a brief description of the individual components of the computerized hand controller:

1. **Liquid Crystal Display (LCD) Window:** Has a dual-line, 16 character display screen that is backlit for comfortable viewing of telescope information and scrolling text.
2. **Align:** Instructs the telescope to use a selected star or object as an alignment position.
3. **Direction Keys:** Allows complete control of the telescope in any direction. Use the direction keys to move the telescope to the initial alignment stars or for centering objects in the eyepiece.



**Figure 3-1**  
**The Advanced GT Hand Control**



4. **Catalog Keys:** The Advanced Series has keys on the hand control to allow direct access to each of the catalogs in its database. The hand control contains the following catalogs in its database:

**Messier** – Complete list of all Messier objects.

**NGC** – Complete list of all the deep-sky objects in the Revised New General Catalog.

**Caldwell** – A combination of the best NGC and IC objects.

**Planets** - All 8 planets in our Solar System plus the Moon.

**Stars** – A compiled list of the brightest stars from the SAO catalog.

**List** – For quick access, all of the best and most popular objects in the Advanced GT database have been broken down into lists based on their type and/or common name:

<b>Named Stars</b>	Common name listing of the brightest stars in the sky.
<b>Named Objects</b>	Alphabetical listing of over 50 of the most popular deep sky objects.
<b>Double Stars</b>	Numeric-alphabetical listing of the most visually stunning double, triple and quadruple stars in the sky.
<b>Variable Stars</b>	Select list of the brightest variable stars with the shortest period of changing magnitude.
<b>Asterisms</b>	A unique list of some of the most recognizable star patterns in the sky.
<b>CCD Objects</b>	A custom list of many interesting galaxy pairs, trios and clusters that are well suited for CCD imaging with the Advanced GT telescope.
<b>IC Objects</b>	A complete list of all the Index Catalog deep-sky objects.
<b>Abell Objects</b>	A custom list of the Abell Catalog deep-sky galaxies.
<b>Constellation</b>	A complete list of all 88 constellations.

5. **Info:** Displays coordinates and useful information about objects selected from the Advanced GT database.
6. **Tour:** Activates the tour mode, which seeks out all the best objects for the current date and time, and automatically slews the telescope to those objects.
7. **Enter:** Pressing *Enter* allows you to select any of the Advanced GT functions and accept entered parameters.
8. **Undo:** *Undo* will take you out of the current menu and display the previous level of the menu path. Press *Undo* repeatedly to get back to a main menu or use it to erase data entered by mistake.
9. **Menu:** Displays the many setup and utilities functions such as tracking rates and user defined objects and many others.
10. **Scroll Keys:** Used to scroll up and down within any of the menu lists. A double-arrow will appear on the right side of the LCD when there are sub-menus below the displayed menu. Using these keys will scroll through those sub-menus.
11. **Rate:** Instantly changes the rate of speed of the motors when the direction buttons are pressed.
12. **RS-232 Jack:** Allows you to interface with a computer and control the telescope remotely.

## Hand Control Operation

This section describes the basic hand control procedures needed to operate the GT Series Telescopes. These procedures are grouped into three categories: Alignment, Setup and Utilities. The alignment section deals with the initial telescope alignment as well as finding objects in the sky; the setup section discusses changing parameters such as tracking mode and tracking rate; finally, the last section reviews all of the utilities functions such as calibrating your mount, polar alignment and backlash compensation.

## Alignment Procedures

In order for the telescope to accurately point to objects in the sky, it must first be aligned to three known positions (stars) in the sky. With this information, the telescope can create a model of the sky, which it uses to locate any object with known coordinates. There are many ways to align your telescope with the sky depending on what information the user is able to provide: **Auto Align** allows the telescope to select three stars and uses the entered time/location information to align the telescope; **Auto Three Star Align** involves the same process as *Auto Align*, however it allows the user to select which star to use to align the telescope. **Quick-Align** will ask you to input all the same information as you would for the Auto Align procedure. However, instead of slewing to the alignment stars for centering and alignment, the telescope bypasses this step and simply models the sky based on the information given. Finally, **Last Alignment** restores your last saved star alignment and switch position. Last Alignment also serves as a good safeguard in case the telescope should lose power.

## Startup Procedure

Before any of the described alignments are performed, the telescope mount needs to be positioned so that the index marks are aligned on both the right ascension and declination axes (see Fig 2-8).

First index its switch position so that each axis has an equal amount of travel to move in either direction. Once the index position has been set, the hand control will display the last entered date and time information stored in the hand control. Once the telescope is powered on:

1. Press ENTER begin the alignment process.
2. The hand control will ask the user to set the mount to its index position. Move the telescope mount, either manually or with the hand control, so that the index marked in both R.A. and Dec are aligned (see Fig 2-8). Press *Enter* to continue.
3. The hand control will then display the last entered local time, date, time zone, longitude and latitude.
  - Use the Up/Down keys (10) to view the current parameters.
  - Press ENTER to accept the current parameters.
  - Press UNDO to enter current date and time information into the hand control. The following information will be displayed:

**Time** - Enter the current local time for your area. You can enter either the local time (i.e. 08:00), or you can enter military time (i.e. 20:00).

- Select PM or AM. If military time was entered, the hand control will bypass this step.
- Choose between Standard time or Daylight Savings time. Use the Up and Down scroll buttons (10) to toggle between options.
- Select the time zone that you are observing from. Again, use the Up and Down buttons (10) to scroll through the choices. Refer to Time Zone map in Appendix for more information.

**Date** - Enter the month, day and year of your observing session.

- Finally, you must enter the longitude and latitude of the location of your observing site. Use the table in Appendix C to locate the closest longitude and latitude for your current observing location and enter those numbers when asked in the hand control, pressing ENTER after each entry. Remember to select "West" for longitudes in North America and "North" for latitudes in the North Hemisphere. For international cities, the correct hemisphere is indicated in the Appendix listings.

### Mount Calibration

After an Auto Align is successfully completed, the hand control will display the message, Calibrating...

This automatic calibration routine is necessary to calculate and compensates for "cone" error inherent in all German equatorial mounts. Cone error is the inaccuracy that results from the optical tube not being exactly perpendicular to the mounts declination axis as well as various other inaccuracies such as backlash in the mounts gears. The telescope is able to automatically determine the cone error value by always using alignment stars on both sides of the Meridian (see Figure 3-2). Mechanical errors can be reduced further by always centering alignment stars using the up and right arrow buttons as described in the Pointing Accuracy box below.

4. Select one of the four alignment methods as described below.

Note: If incorrect information is entered into the hand control, the UNDO button acts like a back space button allowing the user to re-enter the correct data.

## Auto Align

Auto Align allows the telescope to automatically choose three stars (two on one side of the Meridian, and one on the opposite side) on which to align itself. To Auto Align your telescope:

1. Select Auto Align from the alignment choices given. Based on the date and time information entered, the telescope will automatically select and go to a bright star that is above the horizon.
  - If for some reason the chosen star is not visible (perhaps behind a tree or building) press UNDO to automatically select the next bright star from the database star list.
2. Once the telescope is finished slewing to your first alignment star, the display will ask you to use the arrow buttons to align the selected star with the crosshairs in the center of the finderscope. Once centered in the finder, press ENTER.
3. The display will then instruct you to center the star in the field of view of the eyepiece. When the star is centered, press ALIGN to accept this star as your first alignment star.
4. After the first alignment star has been entered the telescope will automatically select a second alignment star on the same side of the Meridian and have you repeat this procedure for that star.
5. For the third alignment star, the telescope will select a bright star on the opposite side of the Meridian and slew to it. Once again center the star in the crosshairs of the finderscope and then center the star in the eyepiece, pressing ENTER when complete.

When the telescope has been aligned on all three stars the display will read Alignment Successful, and you are now ready to find your first object.

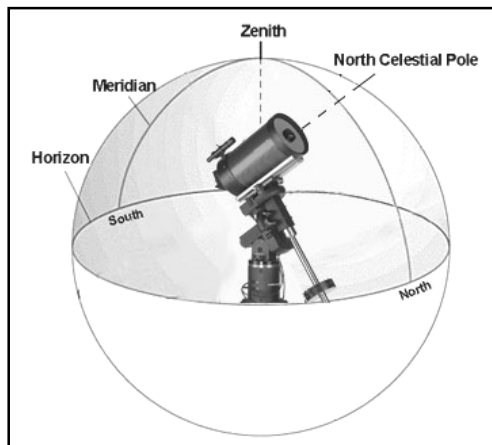

**Figure 3-2**

The Meridian is an imaginary line in the sky that starts at the North celestial pole and ends at the South celestial pole and passes through the zenith. If you are facing South, the meridian starts from your Southern horizon and passes directly overhead to the North celestial pole.

## Auto Three-Star Align

Auto Three-Star Alignment works much the same way as Auto Align, however instead of automatically slewing to the alignment stars, the user is allowed to select the alignment stars from a list. To use *Auto Three-Star Align*:

1. Select Auto Three Star Align from the alignment choices given.
2. The hand control will display a recommended alignment star to begin.
  - Press UNDO to display the next recommended star on the same side of the Meridian, or
  - Press the UP and DOWN arrows keys to scroll through the complete list of available alignment stars to choose from.
3. Once the desired alignment star is displayed on the hand control press ENTER to slew the telescope to the star.

### Pointing Accuracy

For the best possible pointing accuracy, always center the alignment stars using the up arrow button and the right arrow button. Approaching from this direction when looking through the eyepiece will eliminate much of the backlash between the gears and assures the most accurate alignment possible.

4. As with the Auto Align procedure, you will be asked to center the star in the crosshairs of the finderscope and then center the star in the eyepiece, pressing ENTER when complete.

NOTE: Although the telescope allows the user to select the alignment stars, for best all-sky pointing accuracy it is still necessary to select two alignment stars on one side of the Meridian and the third star on the opposite side of the Meridian. For this reason, the hand control will only display stars that are on the same side of the Meridian for the first two alignment stars, then will only display stars on the opposite side of the Meridian for the third alignment star.

## Quick-Align

Quick-Align uses all the date and time information entered at startup to align the telescope. However, instead of slewing to the alignment stars for centering and alignment, the telescope bypasses this step and simply models the sky based on the information given. This will allow you to roughly slew to the coordinates of bright objects like the moon and planets and gives the telescope the information needed to track objects in any part of the sky (depending on accuracy of polar alignment). Quick-Align is not meant to be used to accurately locate small or faint deep-sky objects or to track objects accurately for photography.

To use Quick-Align, simply select Quick Align from the alignment options and press ENTER. The telescope will automatically use the entered date/time parameters to align itself with the sky and display *Alignment Successful*.

NOTE: Once a Quick-Align has been done, you can use the Re-alignment feature (see below) to improve your telescopes pointing accuracy.

## Last Alignment

The *Last Alignment* method will automatically recall the last stored index positions to continue using the alignment that was saved when the telescope was last powered down. This is a useful feature should your telescope accidentally lose power or be powered down.

NOTE: Just like with Quick-Align, you can use the Re-alignment feature (see below) to improve your telescopes pointing accuracy after using the *Last Alignment* method. To maintain a more accurate alignment over a series of observing sessions, use the *Hibernate* feature described later in this chapter.

## Re-Alignment

The Advanced Series telescopes have a re-alignment feature which allows you to replace any of the original alignment stars with a new star or celestial object. This can be useful in several situations:

- If you are observing over a period of a few hours, you may notice that your original two alignment stars have drifted towards the west considerably. (Remember that the stars are moving at a rate of 15° every hour). Aligning on a new star that is in the eastern part of the sky will improve your pointing accuracy, especially on objects in that part of the sky.
- If you have aligned your telescope using the Quick-Align method, you can use *re-align* to align on actual objects in the sky. This will improve the pointing accuracy of your telescope without having to re-enter addition information.

To replace an existing alignment star with a new alignment star:

1. Select the desired star (or object) from the database and slew to it.
2. Carefully center the object in the eyepiece.
3. Once centered, press the UNDO button until you are at the main menu.
4. With Advanced GT displayed, press the ALIGN key on the hand control.
5. The display will then ask you which alignment star you want to replace. Use the UP and Down scroll keys to select the alignment star to be replaced. It is usually best to replace the star closest to the new object. This will space out your alignment stars across the sky.
6. Press ALIGN to make the change.

## Object Catalog

### Selecting an Object

Now that the telescope is properly aligned, you can choose an object from any of the catalogs in the telescope's extensive database. The hand control has a key (4) designated for each of the catalogs in its database. There are two ways to select objects from the database: scrolling through the named object lists and entering object numbers.

Pressing the LIST key on the hand control will access all objects in the database that have common names or types. Each list is broken down into the following categories: Named Stars, Named Object, Double Stars, Variable Stars, Asterisms and CCD Objects. Selecting any one of these catalogs will display a numeric-alphabetical listing of the objects under that list. Pressing the Up and Down keys (10) allows you to scroll through the catalog to the desired object.



**Helpful  
Hint**

*When scrolling through a long list of objects, holding down either the Up or Down key will allow you to scroll through the catalog more rapidly by only displaying every fifth catalog object.*

Pressing any of the other catalog keys (M, CALD, NGC, or STAR) will display a blinking cursor below the name of the catalog chosen. Use the numeric key pad to enter the number of any object within these standardized catalogs. For example, to find the Orion Nebula, press the "M" key and enter "042".

### Slewing to an Object

Once the desired object is displayed on the hand control screen, choose from the following options:

- **Press the INFO Key.** This will give you useful information about the selected object such as R.A. and declination, magnitude size and text information for many of the most popular objects.
- **Press the ENTER Key.** This will automatically slew the telescope to the coordinates of the object.

**Caution: Never slew the telescope when someone is looking into the eyepiece. The telescope can move at fast slew speeds and may hit an observer in the eye.**

Object information can be obtained without having to do a star alignment. After the telescope is powered on, pressing any of the catalog keys allows you to scroll through object lists or enter catalog numbers and view the information about the object as described above.

### Finding Planets

Your telescope can locate all 8 of our solar systems planets plus the Moon. However, the hand control will only display the solar system objects that are above the horizon (or within its filter limits). To locate the planets, press the PLANET key on the hand control. The hand control will display all solar system objects that are above the horizon:

- Use the **Up and Down** keys to select the planet that you wish to observe.
- Press **INFO** to access information on the displayed planet.
- Press **ENTER** to slew to the displayed planet.

## Tour Mode

The Advanced Series telescopes include a tour feature which automatically allows the user to choose from a list of interesting objects based on the date and time in which you are observing. The automatic tour will display only those objects that are within your set filter limits (see *Filter Limits* in the *Setup Procedures* section of the manual). To activate the Tour mode, press the TOUR key (6) on the hand control. The hand control will display the best objects to observe that are currently in the sky.

- To see information and data about the displayed object, press the INFO key.
- To slew to the object displayed, press ENTER.
- To see the next tour object, press the Up key.

## Constellation Tour

In addition to the Tour Mode, your telescope has a Constellation Tour that allows the user to take a tour of all the best objects in each of the 88 constellations. Selecting *Constellation* from the LIST menu will display all the constellation names that are above the user defined horizon (filter limits). Once a constellation is selected, you can choose from any of the database object catalogs to produce a list of all the available objects in that constellation.

- To see information and data about the displayed object, press the INFO key.
- To slew to the object displayed, press ENTER.
- To see the next tour object, press the Up key.

## Direction Buttons

The hand control has four direction buttons (3) in the center of the hand control which control the telescope's motion in altitude (up and down) and azimuth (left and right). The telescope can be controlled at nine different speed rates.

## Rate Button

Pressing the RATE key (11) allows you to instantly change the speed rate of the motors from high speed slew rate to precise guiding rate or anywhere in between. Each rate corresponds to a number on the hand controller key pad. The number 9 is the fastest rate (3° per second, depending on power source) and is used for slewing between objects and locating alignment stars. The number 1 on the hand control is the slowest rate (.5x sidereal) and can be used for accurate centering of objects in the eyepiece and photographic guiding. To change the speed rate of the motors:

- Press the RATE key on the hand control. The LCD will display the current speed rate.
- Press the number on the hand control that corresponds to the desired speed. The number will appear in the upper-right corner of the LCD display to indicate that the rate has been changed.

The hand control has a "double button" feature that allows you to instantly speed up the motors without having to choose a speed rate. To use this feature, simply press the arrow button that corresponds to the direction that you want to move the telescope. While holding that button down, press the opposite directional button. This will increase the slew rate to the maximum slew rate.

The direction that a star moves in the eyepiece when a direction is pressed will change depending on which side of the Meridian the telescope tube is positioned. In order to change the direction of the arrow buttons, see *Scope Setup Features* later in this section.

<i>1 = .5x</i>	<i>6 = 64x</i>
<i>2 = 1x (sidereal)</i>	<i>7 = .5°/sec</i>
<i>3 = 4x</i>	<i>8 = 2°/sec</i>
<i>4 = 8x</i>	<i>9 = 3°/sec</i>
<i>5 = 16x</i>	
<b>Nine available slew speeds</b>	

## Setup Procedures

The Advanced GT contains many user defined setup functions designed to give the user control over the telescope's many advanced features. All of the setup and utility features can be accessed by pressing the MENU key and scrolling through the options:

**Tracking Mode** This allows you to change the way the telescope tracks depending on the type of mount being used to support the telescope. The telescope has three different tracking modes:

**EQ North** Used to track the sky when the telescope is polar aligned in the Northern Hemisphere.

**EQ South** Used to track the sky when the telescope is polar aligned in the Southern Hemisphere.

**Off** When using the telescope for terrestrial (land) observation, the tracking can be turned off so that the telescope never moves.

**Tracking Rate** In addition to being able to move the telescope with the hand control buttons, your telescope will continually track a celestial object as it moves across the night sky. The tracking rate can be changed depending on what type of object is being observed:

**Sidereal** This rate compensates for the rotation of the Earth by moving the telescope at the same rate as the rotation of the Earth, but in the opposite direction. When the telescope is polar aligned, this can be accomplished by moving the telescope in right ascension only.

**Lunar** Used for tracking the moon when observing the lunar landscape.

**Solar** Used for tracking the Sun when solar observing with the proper filter.

**View Time-Site** - Displays the current time and longitude/latitude downloaded from the optional CN-16 GPS receiver. It will also display other relevant time-site information like time zone, daylight saving and local sidereal time. Local sidereal time (LST) is useful for knowing the right ascension of celestial objects that are located on the Meridian at that time. *View Time-Site* will always display the last saved time and location entered while it is linking with the GPS. Once current information has been received, it will update the displayed information. If GPS is switched off or not present, the hand control will only display the last saved time and location.

**User Defined Objects** - Your telescope can store up to 400 different user defined objects in its memory. The objects can be daytime land objects or an interesting celestial object that you discover that is not included in the regular database. There are several ways to save an object to memory depending on what type of object it is:

- GoTo Object:** To go to any of the user defined objects stored in the database, scroll down to either `GoTo Sky Obj` or `Goto Land Obj` and enter the number of the object you wish to select and press ENTER. The telescope will automatically retrieve and display the coordinates before slewing to the object.
- Save Sky Object:** Your telescope stores celestial objects to its database by saving its right ascension and declination in the sky. This way the same object can be found each time the telescope is aligned. Once a desired object is centered in the eyepiece, simply scroll to the "Save Sky Obj" command and press ENTER. The display will ask you to enter a number between 1-200 to identify the object. Press ENTER again to save this object to the database.
- Enter R.A. - Dec:** You can also store a specific set of coordinates for an object just by entering the R.A. and declination for that object. Scroll to the "Enter RA-DEC " command and press ENTER. The display will then ask you to enter first the R.A. and then the declination of the desired object.
- Save Land Object:** The telescope can also be used as a spotting scope on terrestrial objects. Fixed land objects can be stored by saving their altitude and azimuth relative to the location of the telescope at the time of observing. Since these objects are relative to the location of the telescope, they are only valid for that exact location. To save land objects, once again center the desired object in the eyepiece. Scroll down to the "Save Land Obj" command and press ENTER. The display will ask you to enter a number between 1-200 to identify the object. Press ENTER again to save this object to the database.

To replace the contents of any of the user defined objects, simply save a new object using one of the existing identification numbers; the telescope will replace the previous user defined object with the current one.

**Get RA/DEC** - Displays the right ascension and declination for the current position of the telescope.

**Goto R.A/ Dec** - Allows you to input a specific R.A. and declination and slew to it.

**Helpful Hint**

To store a set of coordinates (R.A./Dec) permanently into the database, save it as a *User Defined Object* as described above.

**Identify**

*Identify Mode* will search any of the telescope's database catalogs or lists and display the name and offset distances to the nearest matching objects. This feature can serve two purposes. First, it can be used to identify an unknown object in the field of view of your eyepiece. Additionally, *Identify Mode* can be used to find other celestial objects that are close to the objects you are currently observing. For example, if your telescope is pointed at the brightest star in the constellation Lyra, choosing *Identify* and then searching the *Named Star* catalog will no doubt return the star Vega as the star you are observing. However, by selecting *Identify* and searching by the *Named Object* or *Messier* catalogs, the hand control will let you know that the Ring Nebula (M57) is approximately 6° from your current position. Searching the Double Star catalog will reveal that Epsilon Lyrae is only 1° away from Vega. To use the *Identify* feature:

- Press the Menu button and select the Identify option.
- Use the Up/Down scroll keys to select the catalog that you would like to search.
- Press ENTER to begin the search.

Note: Some of the databases contain thousands of objects, and can therefore take several minutes to return the closest objects.



## Precise GoTo

The Advanced Series telescopes have a precise goto function that can assist in finding extremely faint objects and centering objects closer to the center of the field of view for astrophotography and CCD imaging. Precise Goto automatically searches out the closest bright star to the desired object and asks the user to carefully center it in the eyepiece. The hand control then calculates the small difference between its goto position and its centered position. Using this offset, the telescope will then slew to the desired object with enhanced accuracy. To use Precise Goto:

1. Press the MENU button and use the Up/Down keys to select *Precise Goto*.
  - Choose *Database* to select the object that you want to observe from any of the database catalogs listed or;
  - Choose *RA/DEC* to enter a set of celestial coordinates that you wish to slew to.
2. Once the desired object is selected, the hand control will search out and display the closest bright star to your desired object. Press ENTER to slew to the bright alignment star.
3. Use the direction buttons to carefully center the alignment star in the eyepiece.
4. Press ENTER to slew to the desired object.

## Scope Setup Features

**Setup Time-Site** - Allows the user to customize the telescope's display by changing time and location parameters (such as time zone and daylight savings).

**Anti-backlash** – All mechanical gears have a certain amount of backlash or play between the gears. This play is evident by how long it takes for a star to move in the eyepiece when the hand control arrow buttons are pressed (especially when changing directions). The Advanced GT's anti-backlash features allows the user to compensate for backlash by inputting a value which quickly rewinds the motors just enough to eliminate the play between gears. The amount of compensation needed depends on the slewing rate selected; the slower the slewing rate the longer it will take for the star to appear to move in the eyepiece. There are two values for each axis, positive and negative. Positive is the amount of compensation applied when you press the button, in order to get the gears moving quickly without a long pause. Negative is the amount of compensation applied when you release the button, winding the motors back in the other direction to resume tracking. Normally both values should be the same. You will need to experiment with different values (from 0-99); a value between 20 and 50 is usually best for most visual observing, whereas a higher value may be necessary for photographic guiding.

To set the anti-backlash value, scroll down to the *anti-backlash* option and press ENTER. While viewing an object in the eyepiece, observe the responsiveness of each of the four arrow buttons. Note which directions you see a pause in the star movement after the button has been pressed. Working one axis at a time, adjust the backlash settings high enough to cause immediate movement without resulting in a pronounced jump when pressing or releasing the button. Now, enter the same values for both positive and negative directions. If you notice a jump when releasing the button, but setting the values lower results in a pause when pressing the button, go with the higher value for positive, but use a lower value for negative. The telescope will remember these values and use them each time it is turned on until they are changed.

**Filter Limits** – When an alignment is complete, the telescope automatically knows which celestial objects are above the horizon. As a result, when scrolling through the database lists (or selecting the Tour function), the hand control will display only those objects that are known to be above the horizon when you are observing. You can customize the object database by selecting altitude limits that are appropriate for your location and situation. For example, if you are observing from a mountainous location where the horizon is partially obscured, you can set your

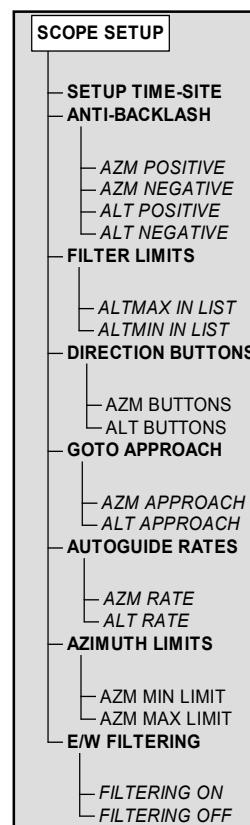

minimum altitude limit to read +20°. This will make sure that the hand control only displays objects that are higher in altitude than 20°.

**Observing Tip!** *If you want to explore the entire object database, set the maximum altitude limit to 90° and the minimum limit to -90°. This will display every object in the database lists regardless of whether it is visible in the sky from your location.*

**Direction Buttons** –The direction a star appears to move in the eyepiece changes depending on which side of the Meridian the telescope tube is on. This can create confusion especially when guiding on a star when doing astrophotography. To compensate for this, the direction of the drive control keys can be changed. To reverse the button logic of the hand control, press the MENU button and select *Direction Buttons* from the Utilities menu. Use the Up/Down arrow keys (10) to select either the azimuth (right ascension) or altitude (declination) button direction and press ENTER. Select either positive or negative for both axes and press ENTER to save. Setting the azimuth button direction to positive will move the telescope in the same direction that the telescope tracks (i.e. towards the west). Setting the altitude buttons to positive will move the telescope counterclockwise along the DEC axis.

**Goto Approach** - lets the user define the direction that the telescope will approach when slewing to an object. This allows the user the ability to minimize the affects of backlash when slewing from object to object. Just like with *Direction Buttons*, setting *GoTo Approach* to positive will make the telescope approach an object from the same direction as tracking (west) for azimuth and counterclockwise in declination. Declination Goto approach will only apply while the telescope tube is on one side of the Meridian. Once the tube passes over to the other side of the Meridian, the Goto approach will need to be reversed.

To change the Goto approach direction, simply choose *Goto Approach* from the *Scope Setup* menu, select either Altitude or Azimuth approach, choose positive or negative and press ENTER.

**Helpful Hint!** In order to minimize the affect of gear backlash on pointing accuracy, the settings for *Button Direction* should ideally match the settings for *GoTo Approach*. By default, using the up and right direction buttons to center alignment stars will automatically eliminate much of the backlash in the gears. If you change the Goto approach of your telescope it is not necessary to change the Button Direction as well. Simply take notice of the direction the telescope moves when completing it final goto approach. If the telescope approaches its alignment star from the west (negative azimuth) and clockwise (negative altitude) then make sure that the buttons used to center the alignment stars also move the telescope in the same directions.

**Autoguide Rate** – Allows the user to set an autoguide rate as a percentage of sidereal rate. This is helpful when calibrating your telescope to a CCD autoguider for long exposure photography.

**Azimuth Limits** - Sets the limits that the telescope can slew in azimuth (R.A.) The slew limits are set to 0° to 180°; with zero being the position of the telescope when the counterweight bar is extended out towards the west and 180° being the position when the counterweight bar is extended out toward the east (see Fig 3-3). However, the slew limits can be customized depending on your needs. For example, if you are using CCD imaging equipment that has cables that are not long enough to move with the telescope as it slews across the sky, you can adjust the azimuth slew limit on the side of the mount that is restricted by the cables. Using the example above, the user could slew the telescope in R.A. (azimuth) until it reaches the point that the cables are extended to their maximum. Then by displaying the

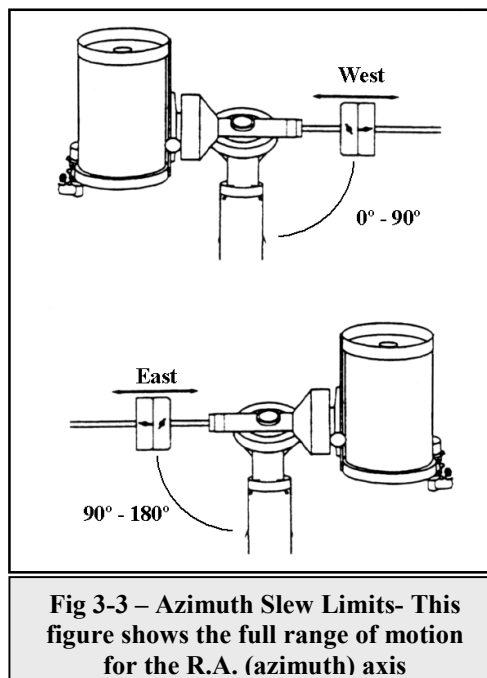

**Fig 3-3 – Azimuth Slew Limits- This figure shows the full range of motion for the R.A. (azimuth) axis**

telescopes azimuth in this position (by looking at *Get Alt-Az* under the *Utilities* menu) you can determine the telescopes azimuth at its most extended position. Enter this azimuth reading for either the maximum or minimum azimuth slew limit to ensure that the telescope will not slew beyond this point.

**Warning:** In order for the telescope to be able to slew to a star from the direction that minimizes the amount of backlash in the gears, it may be necessary for the telescope to slew beyond the specified slew limit in order to approach the star from the correct direction. This can limit your ability to slew to an object by as much as 6° from the azimuth slew limit set in the hand control. If this proves to be a problem, the direction that the telescope takes to center an object can be changed. To change the telescopes slewing direction, see *Goto Approach* under the *Scope Setup* menu. In order to guaranty that the telescope will have a full range of motion in R.A. (azimuth), set the azimuth slew limits to 354 and 186. This will allow the mount to slew without regard to the slew limits.

**East/West (E/W) Filtering** - In order to ensure the best possible full sky pointing accuracy, the Advanced series telescopes automatically filters and chooses its initial alignment stars so that the first two alignment stars are located on one side of the Meridian and the third star is on the opposite side of the Meridian. *East/West Filtering* allows you to turn off this automatic filtering feature, allowing the hand control to display all of its alignment stars when doing a *Auto Three Star Align*, without regard to the Meridian.

## Utility Features

Scrolling through the MENU (9) options will also provide access to several advanced utility functions within the Advanced Series telescopes such as; Calibrate Goto, Polar Alignment, Hibernate as well as many others.

**Calibrate Goto** - Goto Calibration is a useful tool when attaching heavy visual or photographic accessories to the telescope. Goto Calibration calculates the amount of distance and time it takes for the mount to complete its final slow goto when slewing to an object. Changing the balance of the telescope can prolong the time it takes to complete the final slew. Goto Calibration takes into account any slight imbalances and changes the final goto distance to compensate.

**Home Position** – The telescopes "home" position is a user-definable position that is used to store the telescope when not in use. The home position is useful when storing the telescope in a permanent observatory facility. By default the Home position is the same as the index position used when aligning the mount. To set the *Home* position for your mount simply use the arrow buttons on the hand control to move the telescope mount to the desired position. Select the *Set* option and press Enter.

**Polar Align**- The Advanced GT has a polar alignment function that will help you polar align your telescope for increased tracking precision and astrophotography. After performing an Auto Alignment, the telescope will slew to where Polaris should be. By using the equatorial head to center Polaris in the eyepiece, the mount will then be pointed towards the actual North Celestial Pole. Once *Polar Align* is complete, you must re-align your telescope again using any of the alignment methods described earlier. To polar align the mount in the Northern Hemisphere:

1. With the telescope set up and roughly positioned towards Polaris, align the mount using the *Auto Align* or *Auto Three Star* method.
2. Select *Polar Align* from the *Utilities* menu and press Enter.

Based on your current alignment, the telescope will slew to where it thinks Polaris should be. Use the equatorial head latitude and azimuth adjustments to place Polaris in the center of the eyepiece. Do not use the direction buttons to position Polaris. Once Polaris is centered in the eyepiece press ENTER; the polar axis should then be pointed towards the North Celestial Pole.

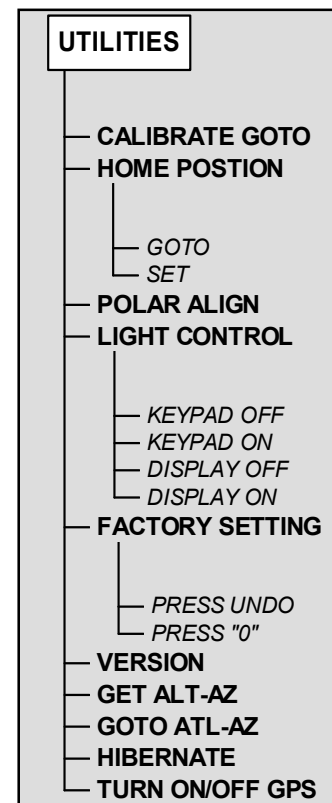

**Light Control** – This feature allows you to turn off both the red key pad light and LCD display for daytime use to conserve power and to help preserve your night vision.

**Factory Settings** – Returns the Advanced GT hand control to its original factory settings. Parameters such as backlash compensation values, initial date and time, longitude/latitude along with slew and filter limits will be reset. However, stored parameters such as user defined objects will remain saved even when *Factory Settings* is selected. The hand control will ask you to press the "0" key before returning to the factory default setting.

**Version** - Selecting this option will allow you to see the current version number of the hand control, motor control and GPS software (if using optional CN-16 GPS accessory). The first set of numbers indicate the hand control software version. For the motor control, the hand control will display two sets of numbers; the first numbers are for azimuth and the second set are for altitude. On the second line of the LCD, the GPS and serial bus versions are displayed.

**Get Alt-Az** - Displays the relative altitude and azimuth for the current position of the telescope.

**Goto Alt-Az** - Allows you to enter a specific altitude and azimuth position and slew to it.

**Hibernate** - Hibernate allows the telescope to be completely powered down and still retain its alignment when turned back on. This not only saves power, but is ideal for those that have their telescopes permanently mounted or leave their telescope in one location for long periods of time. To place your telescope in Hibernate mode:

1. Select Hibernate from the Utility Menu.
2. Move the telescope to a desire position and press ENTER.
3. Power off the telescope. Remember to never move your telescope manually while in Hibernate mode.

Once the telescope is powered on again the display will read Wake Up. After pressing Enter you have the option of scrolling through the time/site information to confirm the current setting. Press ENTER to wake up the telescope.

**Helpful  
Hint**

*Pressing UNDO at the Wake Up screen allows you to explore many of the features of the hand control without waking the telescope up from hibernate mode. To wake up the telescope after UNDO has been pressed, select Hibernate from the Utility menu and press ENTER. Do not use the direction buttons to move the telescope while in hibernate mode.*

**Turn On/Off GPS** - If using your Advanced GT telescope with the optional CN-16 GPS accessory (see *Optional Accessories* section of the manual), you will need to turn the GPS on the first time you use the accessory. . If you want to use the telescope's database to find the coordinates of a celestial object for a future or past dates you would need to turn the GPS off in order to manually enter a time other than the present.

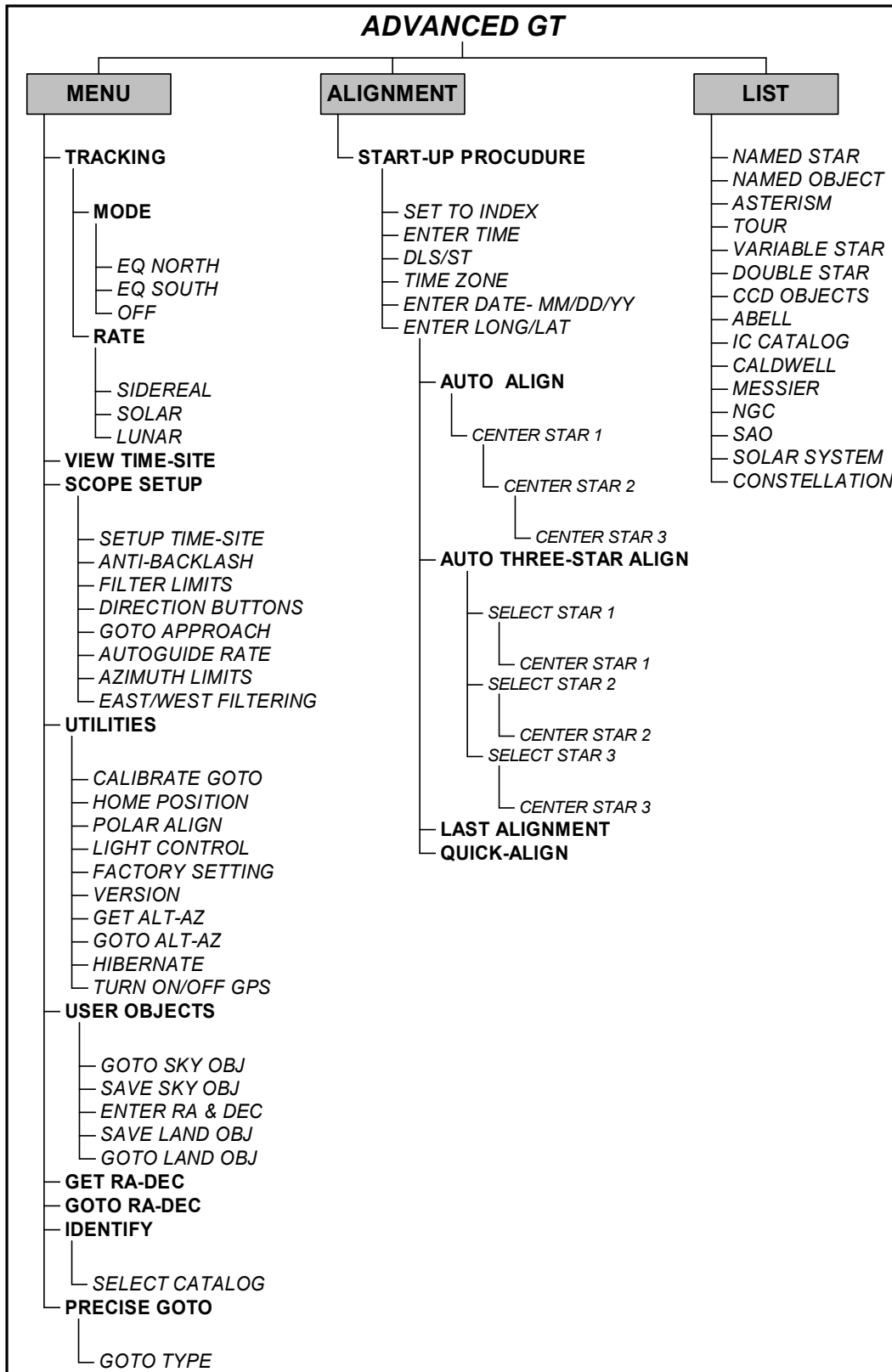



# Telescope Basics

A telescope is an instrument that collects and focuses light. The nature of the optical design determines how the light is focused. Some telescopes, known as refractors, use lenses. Other telescopes, known as reflectors, use mirrors. The Schmidt-Cassegrain optical system (or Schmidt-Cass for short) uses a combination of mirrors and lenses and is referred to as a compound or catadioptric telescope. This unique design offers large-diameter optics while maintaining very short tube lengths, making them extremely portable. The Schmidt-Cassegrain system consists of a zero power corrector plate, a spherical primary mirror, and a secondary mirror. Once light rays enter the optical system, they travel the length of the optical tube three times.

The optics of the Advanced Series Schmidt-Cassegrain telescopes have Starbright coatings - enhanced multi-layer coatings on the primary and secondary mirrors for increased reflectivity and a fully coated corrector for the finest anti-reflection characteristics.

Inside the optical tube, a black tube extends out from the center hole in the primary mirror. This is the primary baffle tube and it prevents stray light from passing through to the eyepiece or camera.

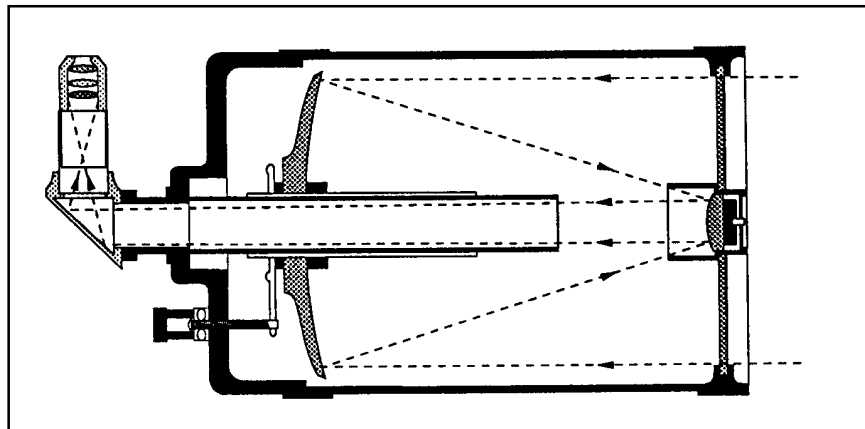

**Figure 4-1**  
*A cutaway view of the light path of the Schmidt-Cassegrain optical design*

## Image Orientation

The image orientation changes depending on how the eyepiece is inserted into the telescope. When using the star diagonal, the image is right-side-up, but reversed from left-to-right (i.e., mirror image). If inserting the eyepiece directly into the visual back (i.e., without the star diagonal), the image is upside-down and reversed from left-to-right (i.e., inverted). This is normal for the Schmidt-Cassegrain design.



**Actual image orientation as seen with the unaided eye**



**Reversed from left to right, as viewed with a Star Diagonal**



**Inverted image, as viewed with the eyepiece directly in telescope**

**Figure 4-2**

## Focusing

The Schmidt-Cassegrain focusing mechanism controls the primary mirror which is mounted on a ring that slides back and forth on the primary baffle tube. The focusing knob, which moves the primary mirror, is on the rear cell of the telescope just below the star diagonal and eyepiece. Turn the focusing knob until the image is sharp. If the knob will not turn, it has reached the end of its travel on the focusing mechanism. Turn the knob in the opposite direction until the image is sharp. Once an image is in focus, turn the knob clockwise to focus on a closer object and counterclockwise for a more distant object. A single turn of the focusing knob moves the primary mirror only slightly. Therefore, it will take many turns (about 30) to go from close focus (approximately 60 feet) to infinity.

For astronomical viewing, out of focus star images are very diffuse, making them difficult to see. If you turn the focus knob too quickly, you can go right through focus without seeing the image. To avoid this problem, your first astronomical target should be a bright object (like the Moon or a planet) so that the image is visible even when out of focus. Critical focusing is best accomplished when the focusing knob is turned in such a manner that the mirror moves against the pull of gravity. In doing so, any mirror shift is minimized. For astronomical observing, both visually and photographically, this is done by turning the focus knob counterclockwise.

**NOTE: Before turning the focus knob, remember to loosen to two mirror locking knobs located on the rear cell of the telescope. These knobs connect a screw to the primary mirror mounting plate and prevent the mirror from moving when locked down. These screws should be locked down when transporting the telescope.**

## Aligning the Finderscope

Accurate alignment of the finder makes it easy to find objects with the telescope, especially celestial objects. To make aligning the finder as easy as possible, this procedure should be done in the daytime when it is easy to find and identify objects. The finderscope has a spring-loaded adjustment screw that puts pressure on the finderscope while the remaining screws are used to adjust the finder horizontally and vertically. To align the finder:

- 1 Choose a target that is in excess of one mile away. This eliminates any possible parallax effect between the telescope and finder.
- 2 Release the altitude and azimuth clamps and point the telescope at your target.
- 3 Center your target in the main optics of the telescope. You may have to move the telescope slightly to center it.
- 4 Adjust the screw on the finder bracket that is on the right (when looking through the finder) until the crosshairs are centered horizontally on the target seen through the telescope.
- 5 Adjust the screw on the top of the finder bracket until the crosshairs are centered vertically on the target seen through the telescope.

Image orientation through the finder is inverted (i.e., upside down and backwards left-to-right). This is normal for any finder that is used straight-through. Because of this, it may take a few minutes to familiarize yourself with the directional change each screw makes on the finder.

## Calculating Magnification

You can change the power of your telescope just by changing the eyepiece (ocular). To determine the magnification of your telescope, simply divide the focal length of the telescope by the focal length of the eyepiece used. In equation format, the formula looks like this:

$$\text{Magnification} = \frac{\text{Focal Length of Telescope (mm)}}{\text{Focal Length of Eyepiece (mm)}}$$

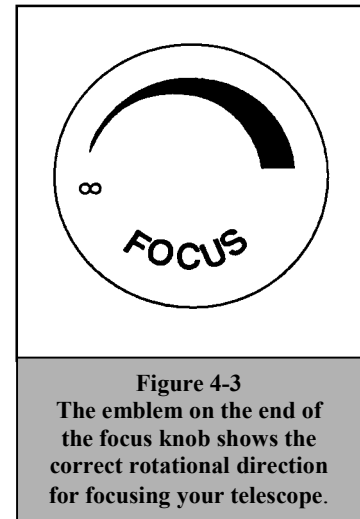

Let's say, for example, you are using the 40mm Plossl eyepiece. To determine the magnification you simply divide the focal length of your telescope (the C8-S for example has a focal length of 2032mm) by the focal length of the eyepiece, 40mm. Dividing 2032 by 40 yields a magnification of 51 power.

Although the power is variable, each instrument under average skies has a limit to the highest useful magnification. The general rule is that 60 power can be used for every inch of aperture. For example, the C8-S is 8 inches in diameter. Multiplying 8 by 60 gives a maximum useful magnification of 480 power. Although this is the maximum useful magnification, most observing is done in the range of 20 to 35 power for every inch of aperture which is 160 to 280 times for the C8-S telescope.

## Determining Field of View

Determining the field of view is important if you want to get an idea of the angular size of the object you are observing. To calculate the actual field of view, divide the apparent field of the eyepiece (supplied by the eyepiece manufacturer) by the magnification. In equation format, the formula looks like this:

$$\text{True Field} = \frac{\text{Apparent Field of Eyepiece}}{\text{Magnification}}$$

As you can see, before determining the field of view, you must calculate the magnification. Using the example in the previous section, we can determine the field of view using the same 40mm eyepiece. The 40mm Plossl eyepiece has an apparent field of view of 46°. Divide the 46° by the magnification, which is 51 power. This yields an actual field of .9°, or nearly a full degree.

To convert degrees to feet at 1,000 yards, which is more useful for terrestrial observing, simply multiply by 52.5. Continuing with our example, multiply the angular field .9° by 52.5. This produces a linear field width of 47 feet at a distance of one thousand yards. The apparent field of each eyepiece that Celestron manufactures is found in the Celestron Accessory Catalog (#93685).

## General Observing Hints

When working with any optical instrument, there are a few things to remember to ensure you get the best possible image.

- Never look through window glass. Glass found in household windows is optically imperfect, and as a result, may vary in thickness from one part of a window to the next. This inconsistency can and will affect the ability to focus your telescope. In most cases you will not be able to achieve a truly sharp image, while in some cases, you may actually see a double image.
- Never look across or over objects that are producing heat waves. This includes asphalt parking lots on hot summer days or building rooftops.
- Hazy skies, fog, and mist can also make it difficult to focus when viewing terrestrially. The amount of detail seen under these conditions is greatly reduced. Also, when photographing under these conditions, the processed film may come out a little grainier than normal with lower contrast and underexposed.
- If you wear corrective lenses (specifically glasses), you may want to remove them when observing with an eyepiece attached to the telescope. When using a camera, however, you should always wear corrective lenses to ensure the sharpest possible focus. If you have astigmatism, corrective lenses must be worn at all times.



# **Astronomy Basics**

Up to this point, this manual covered the assembly and basic operation of your telescope. However, to understand your telescope more thoroughly, you need to know a little about the night sky. This section deals with observational astronomy in general and includes information on the night sky and polar alignment.

## The Celestial Coordinate System

To help find objects in the sky, astronomers use a celestial coordinate system that is similar to our geographical coordinate system here on Earth. The celestial coordinate system has poles, lines of longitude and latitude, and an equator. For the most part, these remain fixed against the background stars.

The celestial equator runs 360 degrees around the Earth and separates the northern celestial hemisphere from the southern. Like the Earth's equator, it bears a reading of zero degrees. On Earth this would be latitude. However, in the sky this is referred to as declination, or DEC for short. Lines of declination are named for their angular distance above and below the celestial equator. The lines are broken down into degrees, minutes of arc, and seconds of arc. Declination readings south of the equator carry a minus sign (-) in front of the coordinate and those north of the celestial equator are either blank (i.e., no designation) or preceded by a plus sign (+).

The celestial equivalent of longitude is called Right Ascension, or R.A. for short. Like the Earth's lines of longitude, they run from pole to pole and are evenly spaced 15 degrees apart. Although the longitude lines are separated by an angular distance, they are also a measure of time. Each line of longitude is one hour apart from the next. Since the Earth rotates once every 24 hours, there are 24 lines total. As a result, the R.A. coordinates are marked off in units of time. It begins with an arbitrary point in the constellation of Pisces designated as 0 hours, 0 minutes, 0 seconds. All other points are designated by how far (i.e., how long) they lag behind this coordinate after it passes overhead moving toward the west.

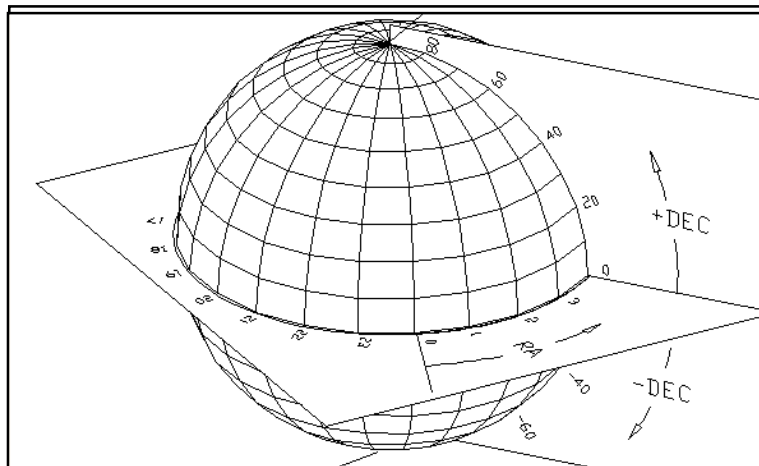

**Figure 5-1**  
The celestial sphere seen from the outside showing R.A. and DEC.

## Motion of the Stars

The daily motion of the Sun across the sky is familiar to even the most casual observer. This daily trek is not the Sun moving as early astronomers thought, but the result of the Earth's rotation. The Earth's rotation also causes the stars to do the same, scribing out a large circle as the Earth completes one rotation. The size of the circular path a star follows depends on where it is in the sky. Stars near the celestial equator form the largest circles rising in the east and setting in the west. Moving toward the north celestial pole, the point around which the stars in the northern hemisphere appear to rotate, these circles become smaller. Stars in the mid-celestial latitudes rise in the northeast and set in the northwest. Stars at high celestial latitudes are always above the horizon, and are said to be circumpolar because they never rise and never set. You will never see the stars complete one circle because the sunlight during the day washes out the starlight. However, part of this circular motion of stars in this region of the sky can be seen by setting up a camera on a tripod and opening the shutter for a couple hours. The processed film will reveal semicircles that revolve around the pole. (This description of stellar motions also applies to the southern hemisphere except all stars south of the celestial equator move around the south celestial pole.)

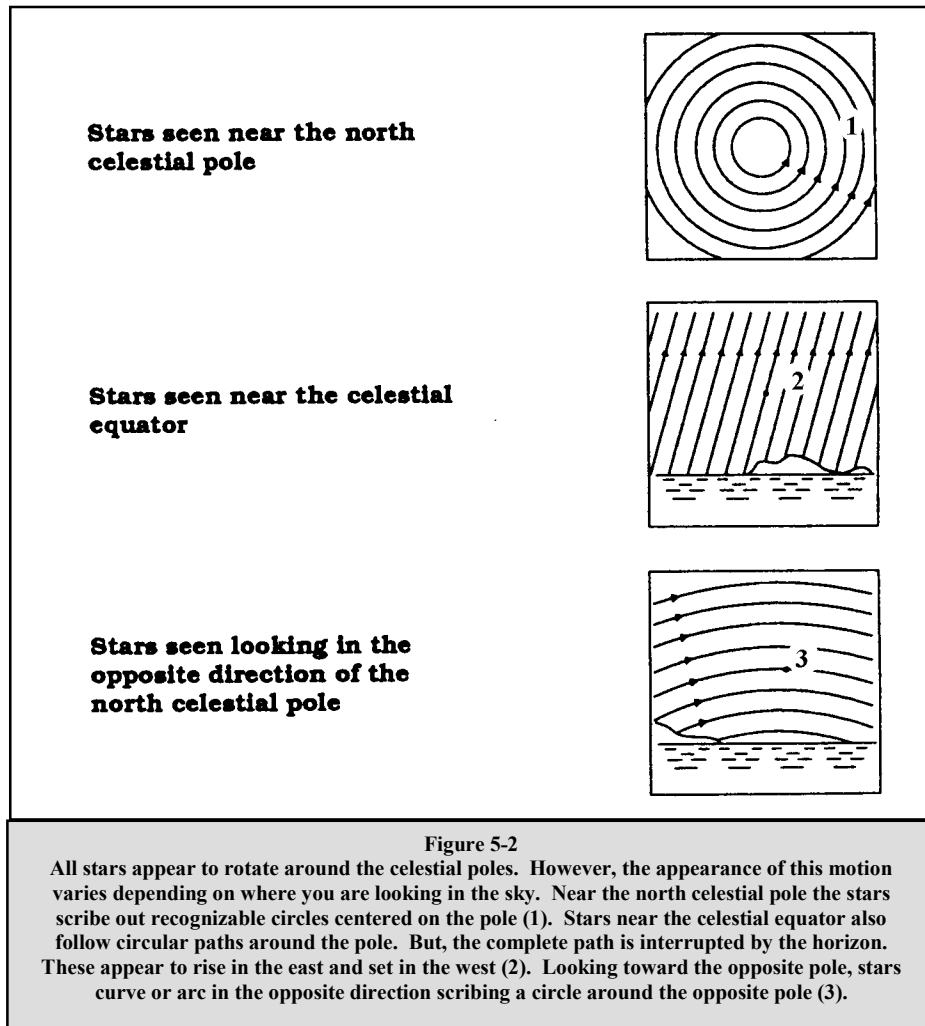

## Latitude Scales

The easiest way to polar align a telescope is with a latitude scale. Unlike other methods that require you to find the celestial pole by identifying certain stars near it, this method works off of a known constant to determine how high the polar axis should be pointed. The Advanced Series mount can be adjusted from 30 to 60 degrees (see figure 5-3).

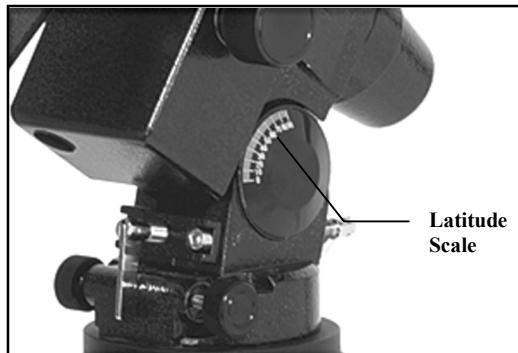

Figure 5-3

The constant, mentioned above, is a relationship between your latitude and the angular distance the celestial pole is above the northern (or southern) horizon; The angular distance from the northern horizon to the north celestial pole is always equal to your latitude. To illustrate this, imagine that you are standing on the north pole, latitude  $+90^\circ$ . The north celestial pole, which has a declination of  $+90^\circ$ , would be directly overhead (i.e.,  $90^\circ$  above the horizon). Now, let's say that you move one degree south — your latitude is now  $+89^\circ$  and the celestial pole is no longer directly overhead. It has moved one degree closer toward the northern horizon. This means the pole is now  $89^\circ$

above the northern horizon. If you move one degree further south, the same thing happens again. You would have to travel 70 miles north or south to change your latitude by one degree. As you can see from this example, the distance from the northern horizon to the celestial pole is always equal to your latitude.

If you are observing from Los Angeles, which has a latitude of  $34^\circ$ , then the celestial pole is  $34^\circ$  above the northern horizon. All a latitude scale does then is to point the polar axis of the telescope at the right elevation above the northern (or southern) horizon. To align your telescope:

1. Make sure the polar axis of the mount is pointing due north. Use a landmark that you know faces north.
2. Level the tripod. There is a bubble level built into the mount for this purpose.

NOTE: Leveling the tripod is only necessary if using this method of polar alignment. Perfect polar alignment is still possible using other methods described later in this manual without leveling the tripod.

3. Adjust the mount in altitude until the latitude indicator points to your latitude. Moving the mount affects the angle the polar axis is pointing. For specific information on adjusting the equatorial mount, please see the section "Adjusting the Mount."

This method can be done in daylight, thus eliminating the need to fumble around in the dark. Although this method does **NOT** put you directly on the pole, it will limit the number of corrections you will make when tracking an object. It will also be accurate enough for short exposure prime focus planetary photography (a couple of seconds) and short exposure piggyback astrophotography (a couple of minutes).

## Pointing at Polaris

This method utilizes Polaris as a guidepost to the celestial pole. Since Polaris is less than a degree from the celestial pole, you can simply point the polar axis of your telescope at Polaris. Although this is by no means perfect alignment, it does get you within one degree. Unlike the previous method, this must be done in the dark when Polaris is visible.

1. Set the telescope up so that the polar axis is pointing north.
2. Loosen the DEC clutch knob and move the telescope so that the tube is parallel to the polar axis. When this is done, the declination setting circle will read  $+90^\circ$ . If the declination setting circle is not aligned, move the telescope so that the tube is parallel to the polar axis.
3. Adjust the mount in altitude and/or azimuth until Polaris is in the field of view of the finder.

- Center Polaris in the field of the telescope using the fine adjustment controls on the mount.

**Remember, while Polar aligning, do NOT move the telescope in R.A. or DEC. You do not want to move the telescope itself, but the polar axis. The telescope is used simply to see where the polar axis is pointing.**

Like the previous method, this gets you close to the pole but not directly on it. The following methods help improve your accuracy for more serious observations and photography.

## Finding the North Celestial Pole

In each hemisphere, there is a point in the sky around which all the other stars appear to rotate. These points are called the celestial poles and are named for the hemisphere in which they reside. For example, in the northern hemisphere all stars move around the north celestial pole. When the telescope's polar axis is pointed at the celestial pole, it is parallel to the Earth's rotational axis.

Many methods of polar alignment require that you know how to find the celestial pole by identifying stars in the area. For those in the northern hemisphere, finding the celestial pole is not too difficult. Fortunately, we have a naked eye star less than a degree away. This star, Polaris, is the end star in the handle of the Little Dipper. Since the Little Dipper (technically called Ursa Minor) is not one of the brightest constellations in the sky, it may be difficult to locate from urban areas. If this is the case, use the two end stars in the bowl of the Big Dipper (the pointer stars). Draw an imaginary line through them toward the Little Dipper. They point to Polaris (see Figure 5-5). The position of the Big Dipper changes during the year and throughout the course of the night (see Figure 5-4). When the Big Dipper is low in the sky (i.e., near the horizon), it may be difficult to locate. During these times, look for Cassiopeia (see Figure 5-5). Observers in the southern hemisphere are not as fortunate as those in the northern hemisphere. The stars around the south celestial pole are not nearly as bright as those around the north. The closest star that is relatively bright is Sigma Octantis. This star is just within naked eye limit (magnitude 5.5) and lies about 59 arc minutes from the pole.

### Definition

*The north celestial pole is the point in the northern hemisphere around which all stars appear to rotate. The counterpart in the southern hemisphere is referred to as the south celestial pole.*

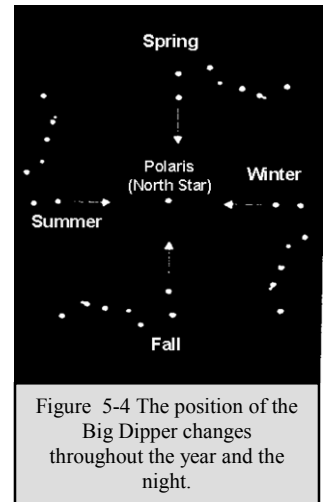

Figure 5-4 The position of the Big Dipper changes throughout the year and the night.

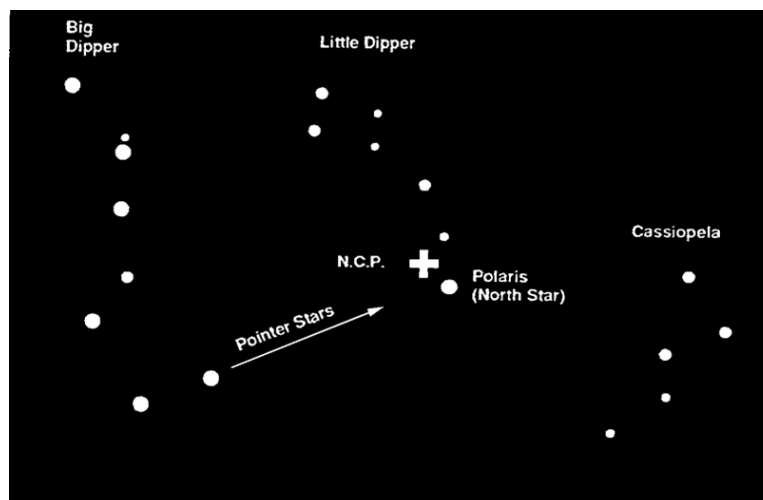

Figure 5-5

The two stars in the front of the bowl of the Big Dipper point to Polaris which is less than one degree from the true (north) celestial pole. Cassiopeia, the "W" shaped constellation, is on the opposite side of the pole from the Big Dipper. The North Celestial Pole (N.C.P.) is marked by the "+" sign.

## Declination Drift Method of Polar Alignment

This method of polar alignment allows you to get the most accurate alignment on the celestial pole and is required if you want to do long exposure deep-sky astrophotography through the telescope. The declination drift method requires that you monitor the drift of selected stars. The drift of each star tells you how far away the polar axis is pointing from the true celestial pole and in what direction. Although declination drift is simple and straight-forward, it requires a great deal of time and patience to complete when first attempted. The declination drift method should be done after any one of the previously mentioned methods has been completed.

To perform the declination drift method you need to choose two bright stars. One should be near the eastern horizon and one due south near the meridian. Both stars should be near the celestial equator (i.e.,  $0^\circ$  declination). You will monitor the drift of each star one at a time and in declination only. While monitoring a star on the meridian, any misalignment in the east-west direction is revealed. While monitoring a star near the east/west horizon, any misalignment in the north-south direction is revealed. It is helpful to have an illuminated reticle eyepiece to help you recognize any drift. For very close alignment, a Barlow lens is also recommended since it increases the magnification and reveals any drift faster. When looking due south, insert the diagonal so the eyepiece points straight up. Insert the cross hair eyepiece and align the cross hairs so that one is parallel to the declination axis and the other is parallel to the right ascension axis. Move your telescope manually in R.A. and DEC to check parallelism.

First, choose your star near where the celestial equator and the meridian meet. The star should be approximately within 1/2 an hour of the meridian and within five degrees of the celestial equator. Center the star in the field of your telescope and monitor the drift in declination.

- If the star drifts south, the polar axis is too far east.
- If the star drifts north, the polar axis is too far west.

Make the appropriate adjustments to the polar axis to eliminate any drift. Once you have eliminated all the drift, move to the star near the eastern horizon. The star should be 20 degrees above the horizon and within five degrees of the celestial equator.

- If the star drifts south, the polar axis is too low.
- If the star drifts north, the polar axis is too high.

Again, make the appropriate adjustments to the polar axis to eliminate any drift. Unfortunately, the latter adjustments interact with the prior adjustments ever so slightly. So, repeat the process again to improve the accuracy checking both axes for minimal drift. Once the drift has been eliminated, the telescope is very accurately aligned. You can now do prime focus deep-sky astrophotography for long periods.

NOTE: If the eastern horizon is blocked, you may choose a star near the western horizon, but you must reverse the polar high/low error directions. Also, if using this method in the southern hemisphere, the direction of drift is reversed for both R.A. and DEC.

# Celestial Observing

With your telescope set up, you are ready to use it for observing. This section covers visual observing hints for both solar system and deep sky objects as well as general observing conditions which will affect your ability to observe.

## Observing the Moon

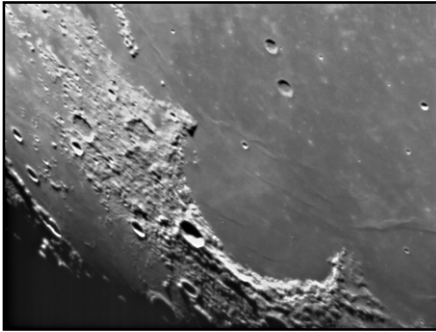

Often, it is tempting to look at the Moon when it is full. At this time, the face we see is fully illuminated and its light can be overpowering. In addition, little or no contrast can be seen during this phase.

One of the best times to observe the Moon is during its partial phases (around the time of first or third quarter). Long shadows reveal a great amount of detail on the lunar surface. At low power you will be able to see most of the lunar disk at one time. The optional Reducer/Corrector lens allows for breath-taking views of the entire lunar disk when used with a low power eyepiece. Change to higher power (magnification) to focus in on a smaller area. Choose the *lunar* tracking rate from the hand control's MENU tracking rate options to keep the moon centered in the eyepiece even at high magnifications.

## Lunar Observing Hints

To increase contrast and bring out detail on the lunar surface, use filters. A yellow filter works well at improving contrast while a neutral density or polarizing filter will reduce overall surface brightness and glare.

## Observing the Planets

Other fascinating targets include the five naked eye planets. You can see Venus go through its lunar-like phases. Mars can reveal a host of surface detail and one, if not both, of its polar caps. You will be able to see the cloud belts of Jupiter and the great Red Spot (if it is visible at the time you are observing). In addition, you will also be able to see the moons of Jupiter as they orbit the giant planet. Saturn, with its beautiful rings, is easily visible at moderate power.

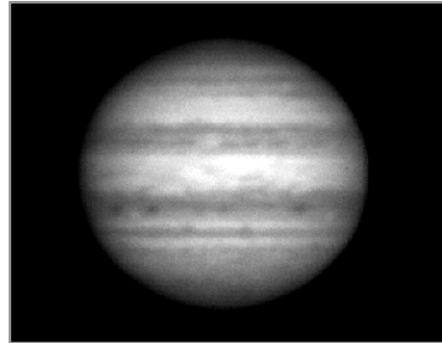

### Planetary Observing Hints

- Remember that atmospheric conditions are usually the limiting factor on how much planetary detail will be visible. So, avoid observing the planets when they are low on the horizon or when they are directly over a source of radiating heat, such as a rooftop or chimney. See the "Seeing Conditions" section later in this section.
- To increase contrast and bring out detail on the planetary surface, try using Celestron eyepiece filters.

## Observing the Sun

Although overlooked by many amateur astronomers, solar observation is both rewarding and fun. However, because the Sun is so bright, special precautions must be taken when observing our star so as not to damage your eyes or your telescope.

Never project an image of the Sun through the telescope. Because of the folded optical design, tremendous heat build-up will result inside the optical tube. This can damage the telescope and/or any accessories attached to the telescope.

For safe solar viewing, use a solar filter that reduces the intensity of the Sun's light, making it safe to view. With a filter you can see sunspots as they move across the solar disk and faculae, which are bright patches seen near the Sun's edge.

## **Solar Observing Hints**

- The best time to observe the Sun is in the early morning or late afternoon when the air is cooler.
- To center the Sun without looking into the eyepiece, watch the shadow of the telescope tube until it forms a circular shadow.
- To ensure accurate tracking, be sure to select the solar tracking rate.

## **Observing Deep Sky Objects**

Deep-sky objects are simply those objects outside the boundaries of our solar system. They include star clusters, planetary nebulae, diffuse nebulae, double stars and other galaxies outside our own Milky Way. Most deep-sky objects have a large angular size. Therefore, low-to-moderate power is all you need to see them. Visually, they are too faint to reveal any of the color seen in long exposure photographs. Instead, they appear black and white. And, because of their low surface brightness, they should be observed from a dark-sky location. Light pollution around large urban areas washes out most nebulae making them difficult, if not impossible, to observe. Light Pollution Reduction filters help reduce the background sky brightness, thus increasing contrast.

## **Seeing Conditions**

Viewing conditions affect what you can see through your telescope during an observing session. Conditions include transparency, sky illumination, and seeing. Understanding viewing conditions and the effect they have on observing will help you get the most out of your telescope.

### **Transparency**

Transparency is the clarity of the atmosphere which is affected by clouds, moisture, and other airborne particles. Thick cumulus clouds are completely opaque while cirrus can be thin, allowing the light from the brightest stars through. Hazy skies absorb more light than clear skies making fainter objects harder to see and reducing contrast on brighter objects. Aerosols ejected into the upper atmosphere from volcanic eruptions also affect transparency. Ideal conditions are when the night sky is inky black.

### **Sky Illumination**

General sky brightening caused by the Moon, aurorae, natural airglow, and light pollution greatly affect transparency. While not a problem for the brighter stars and planets, bright skies reduce the contrast of extended nebulae making them difficult, if not impossible, to see. To maximize your observing, limit deep sky viewing to moonless nights far from the light polluted skies found around major urban areas. LPR filters enhance deep sky viewing from light polluted areas by blocking unwanted light while transmitting light from certain deep sky objects. You can, on the other hand, observe planets and stars from light polluted areas or when the Moon is out.

### **Seeing**

Seeing conditions refers to the stability of the atmosphere and directly affects the amount of fine detail seen in extended objects. The air in our atmosphere acts as a lens which bends and distorts incoming light rays. The amount of bending depends on air density. Varying temperature layers have different densities and, therefore, bend light differently. Light

rays from the same object arrive slightly displaced creating an imperfect or smeared image. These atmospheric disturbances vary from time-to-time and place-to-place. The size of the air parcels compared to your aperture determines the "seeing" quality. Under good seeing conditions, fine detail is visible on the brighter planets like Jupiter and Mars, and stars are pinpoint images. Under poor seeing conditions, images are blurred and stars appear as blobs.

The conditions described here apply to both visual and photographic observations.

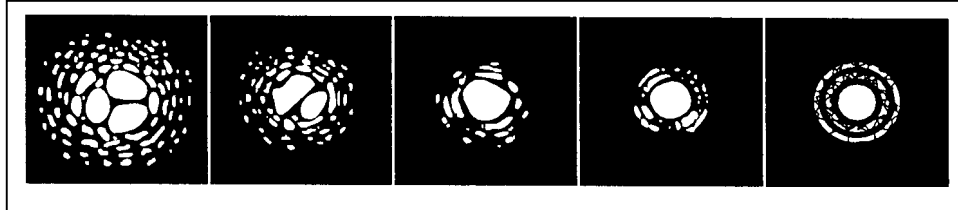

**Figure 6-1**

**Seeing conditions directly affect image quality. These drawings represent a point source (i.e., star) under bad seeing conditions (left) to excellent conditions (right). Most often, seeing conditions produce images that lie some where between these two extremes.**



# **Astrophotography**

After looking at the night sky for a while you may want to try photographing it. Several forms of celestial photography are possible with your telescope, including short exposure prime focus, eyepiece projection, long exposure deep sky, terrestrial and even CCD imaging. Each of these is discussed in moderate detail with enough information to get you started. Topics include the accessories required and some simple techniques. More information is available in some of the publications listed at the end of this manual.

In addition to the specific accessories required for each type of celestial photography, there is the need for a camera - but not just any camera. The camera does not have to have many of the features offered on today's state-of-the-art equipment. For example, you don't need auto focus capability or mirror lock up. Here are the mandatory features a camera needs for celestial photography. First, a "B" setting which allows for time exposures. This excludes point and shoot cameras and limits the selection to SLR cameras, the most common type of 35mm camera on the market today.

Second, the "B" or manual setting should NOT run off the battery. Many new electronic cameras use the battery to keep the shutter open during time exposures. Once the batteries are drained, usually after a few minutes, the shutter closes, whether you were finished with the exposure or not. Look for a camera that has a manual shutter when operating in the time exposure mode. Olympus, Nikon, Minolta, Pentax, Canon and others have made such camera bodies.

The camera must have interchangeable lenses so you can attach it to the telescope and so you can use a variety of lenses for piggyback photography. If you can't find a new camera, you can purchase a used camera body that is not 100-percent functional. The light meter, for example, does not have to be operational since you will be determining the exposure length manually.

You also need a cable release with a locking function to hold the shutter open while you do other things. Mechanical and air release models are available.

## **Short Exposure Prime Focus Photography**

Short exposure prime focus photography is the best way to begin recording celestial objects. It is done with the camera attached to the telescope without an eyepiece or camera lens in place. To attach your camera you need the Celestron T-Adapter (#93633-A) and a T-Ring for your specific camera (i.e., Minolta, Nikon, Pentax, etc.). The T-Ring replaces the 35mm SLR camera's normal lens. Prime focus photography allows you to capture the majority of the lunar disk or solar disk. To attach your camera to your telescope.

1. Remove all visual accessories.
2. Thread the T-Ring onto the T-Adapter.
3. Mount your camera body onto the T-Ring the same as you would any other lens.
4. Thread the T-Adapter onto the back of the telescope while holding the camera in the desired orientation (either vertical or horizontal).

With your camera attached to the telescope, you are ready for prime focus photography. Start with an easy object like the Moon. Here's how to do it:

1. Load your camera with film that has a moderate-to-fast speed (i.e., ISO rating). Faster films are more desirable when the Moon is a crescent. When the Moon is near full, and at its brightest, slower films are more desirable. Here are some film recommendations:
  - T-Max 100

- T-Max 400
  - Any 100 to 400 ISO color slide film
  - Fuji Super HG 400
  - Ektar 25 or 100
2. Center the Moon in the field of your telescope.
  3. Focus the telescope by turning the focus knob until the image is sharp.
  4. Set the shutter speed to the appropriate setting (see table below).
  5. Trip the shutter using a cable release.
  6. Advance the film and repeat the process.

Lunar Phase	ISO 50	ISO 100	ISO 200	ISO 400
Crescent	1/2	1/4	1/8	1/15
Quarter	1/15	1/30	1/60	1/125
Full	1/30	1/60	1/125	1/250

**Table 7-1**  
Above is a listing of recommended exposure times when photographing the Moon at the prime focus of your telescope.

The exposure times listed in table 7-1 should be used as a starting point. Always make exposures that are longer and shorter than the recommended time. Also, take a few photos at each shutter speed. This will ensure that you will get a good photo.

- If using black and white film, try a yellow filter to reduce the light intensity and to increase contrast.
- Keep accurate records of your exposures. This information is useful if you want to repeat your results or if you want to submit some of your photos to various astronomy magazines for possible publication!
- This technique is also used for photographing the Sun with the proper solar filter.

## Eyepiece Projection

This form of celestial photography is designed for objects with small angular sizes, primarily the Moon and planets. Planets, although physically quite large, appear small in angular size because of their great distances. Moderate to high magnification is, therefore, required to make the image large enough to see any detail. Unfortunately, the camera/telescope combination alone does not provide enough magnification to produce a usable image size on film. In order to get the image large enough, you must attach your camera to the telescope with the eyepiece in place. To do so, you need two additional accessories; a deluxe tele-extender (#93643), which attaches to the visual back, and a T-ring for your particular camera make (i.e., Minolta, Nikon, Pentax, etc.).

Because of the high magnifications during eyepiece projection, the field of view is quite small which makes it difficult to find and center objects. To make the job a little easier, align the finder as accurately as possible. This allows you to get the object in the telescope's field based on the finder's view alone.

Another problem introduced by the high magnification is vibration. Simply tripping the shutter — even with a cable release — produces enough vibration to smear the image. To get around this, use the camera's self-timer if the exposure time is less than one second — a common occurrence when photographing the Moon. For exposures over one second, use the "hat trick." This technique incorporates a hand-held black card placed over the aperture of the telescope to

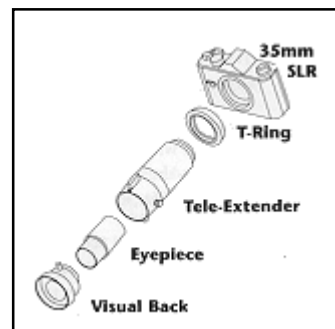

**Figure 7-1 - Accessories for Projection Photography**

act as a shutter. The card prevents light from entering the telescope while the shutter is released. Once the shutter has been released and the vibration has diminished (a few seconds), move the black card out of the way to expose the film. After the exposure is complete, place the card over the front of the telescope and close the shutter. Advance the film and you're ready for your next shot. Keep in mind that the card should be held a few inches in front of the telescope, and not touching it. It is easier if you use two people for this process; one to release the camera shutter and one to hold the card. Here's the process for making the exposure.

1. Find and center the desired target in the viewfinder of your camera.
2. Turn the focus knob until the image is as sharp as possible.
3. Place the black card over the front of the telescope.
4. Release the shutter using a cable release.
5. Wait for the vibration caused by releasing the shutter to diminish. Also, wait for a moment of good seeing.
6. Remove the black card from in front of the telescope for the duration of the exposure (see accompanying table).
7. Replace the black card over the front of the telescope.
8. Close the camera's shutter.

Advance the film and you are ready for your next exposure. Don't forget to take photos of varying duration and keep accurate records of what you have done. Record the date, telescope, exposure duration, eyepiece, f/ratio, film, and some comments on the seeing conditions.

The following table lists exposures for eyepiece projection with a 10mm eyepiece. All exposure times are listed in seconds or fractions of a second.

Planet	ISO 50	ISO 100	ISO 200	ISO 400
<b>Moon</b>	4	2	1	1/2
<b>Mercury</b>	16	8	4	2
<b>Venus</b>	1/2	1/4	1/8	1/15
<b>Mars</b>	16	8	4	2
<b>Jupiter</b>	8	4	2	1
<b>Saturn</b>	16	8	4	2

**Table 7-2**  
**Recommended exposure time for photographing planets.**

The exposure times listed here should be used as a starting point. Always make exposures that are longer and shorter than the recommended time. Also, take a few photos at each shutter speed. This will ensure that you get a good photo. It is not uncommon to go through an entire roll of 36 exposures and have only one good shot.

**NOTE:** Don't expect to record more detail than you can see visually in the eyepiece at the time you are photographing.

Once you have mastered the technique, experiment with different films, different focal length eyepieces, and even different filters.

## Long Exposure Prime Focus Photography

This is the last form of celestial photography to be attempted after others have been mastered. It is intended primarily for deep sky objects, that is objects outside our solar system which includes star clusters, nebulae, and galaxies. While it may seem that high magnification is required for these objects, just the opposite is true. Most of these objects cover large angular areas and fit nicely into the prime focus field of your telescope. The brightness of these objects, however, requires long exposure times and, as a result, are rather difficult.

There are several techniques for this type of photography, and the one chosen will determine the standard accessories needed. The best method for long exposure deep sky astrophotography is with an off-axis guider. This device allows you to photograph and guide through the telescope simultaneously. Celestron offers a very special and advanced off-axis guider, called the Radial Guider (#94176). In addition, you will need a T-Ring to attach your camera to the Radial Guider.

Other equipment needs include a guiding eyepiece. Unlike other forms of astrophotography which allows for fairly loose guiding, prime focus requires meticulous guiding for long periods. To accomplish this you need a guiding ocular with an illuminated reticle to monitor your guide star. For this purpose, Celestron offers the Micro Guide Eyepiece (#94171) Here is a brief summary of the technique.

1. Polar align the telescope. For more information on polar aligning, see the Polar Alignment section earlier in the manual.
2. Remove all visual accessories.
3. Thread the Radial Guider onto your telescope.
4. Thread the T-Ring onto the Radial Guider.
5. Mount your camera body onto the T-Ring the same as you would any other lens.
6. Set the shutter speed to the "B" setting.
7. Focus the telescope on a star.
8. Center your subject in the field of your camera.
9. Find a suitable guide star in the telescope field. This can be the most time consuming process.
10. Open the shutter using a cable release.
11. Monitor your guide star for the duration of the exposure using the buttons on the hand controller to make the needed corrections.
12. Close the camera's shutter.

When getting started, use fast films to record as much detail in the shortest possible time. Here are proven recommendations:

- Ektar 1000 (color print)
- Konica 3200 (color print)
- Fujichrome 1600D (color slide)
- 3M 1000 (color slide)
- Scotchchrome 400
- T-Max 3200 (black and white print)
- T-Max 400 (black and white print)

As you perfect your technique, try specialized films, that is films that are designed or specially treated for celestial photography. Here are some popular choices:

- Ektar 125 (color print)
- Fujichrome 100D (color slide)
- Tech Pan, gas hypered (black and white print)
- T-Max 400 (black and white print)

There is no exposure determination table to help you get started. The best way to determine exposure length is look at previously published photos to see what film/exposure combinations were used. Or take unguided sample photos of various parts of the sky while the drive is running. Always take exposures of various lengths to determine the best exposure time.

## **Terrestrial Photography**

Your telescope makes an excellent telephoto lens for terrestrial (land) photography. Terrestrial photography is best done with the telescope in Alt-Az configuration and the tracking drive turned off. To turn the tracking drive off, press the MENU (9) button on the hand control and scroll down to the Tracking Mode sub menu. Use the Up and Down scroll keys (10) to select the Off option and press ENTER. This will turn the tracking motors off, so that objects will remain in your camera's field of view.

## **Metering**

The Advanced Series telescope has a fixed aperture and, as a result, fixed f/ratios. To properly expose your subjects photographically, you need to set your shutter speed accordingly. Most 35mm SLR cameras offer through-the-lens metering which lets you know if your picture is under or overexposed. Adjustments for proper exposures are made by changing the shutter speed. Consult your camera manual for specific information on metering and changing shutter speeds.

## **Reducing Vibration**

Releasing the shutter manually can cause vibrations, producing blurred photos. To reduce vibration when tripping the shutter, use a cable release. A cable release keeps your hands clear of the camera and lens, thus eliminating the possibility of introducing vibration. Mechanical shutter releases can be used, though air-type releases are best. Blurry pictures can also result from shutter speeds that are too slow. To prevent this, use films that produce shutter speeds greater than 1/250 of a second when hand-holding the lens. If the lens is mounted on a tripod, the exposure length is virtually unlimited.

Another way to reduce vibration is with the Vibration Suppression Pads (#93503). These pads rest between the ground and tripod feet. They reduce the vibration amplitude and vibration time.

## **CCD Imaging**

Advanced GT telescope's versatility allows it to be used in many different f-number configurations for CCD imaging. It can be used at f/6.3 (with the optional Reducer/Corrector), f/10, and f/20 (with the optional 2x Barlow) making it the most versatile imaging system available today. This makes the system ideal for imaging deep-sky objects as well as planetary detail.

The key factors for good CCD imaging are; exposure time, field-of-view, image size, and pixel resolution. As the F/# goes down (or gets faster), the exposure times needed decreases, the field-of-view-increases, but the image scale of the object gets smaller. What is the difference between f/6.3 and f/10? F/6.3 has about 2/3 the focal length of f/10. That makes the exposure time needed about 2.5 times shorter than at f/10, the field of view 50% larger compared to that of f/10. (see Table below)

	Telescope Model	Standard Cassegrain f/10	With Reducer/Corrector f/6.3
Focal Length & Speed	C5-S	49" (1250mm)	31" (788mm)
	C8-S	80" (2032mm)	50.4" (1280mm)
	C9.25-S	93" (2350mm)	58" (1481mm)
ST 237 F.O.V.*	C5-S	13 x 10 (arc min)	20.5 x 15.7 (arc min)
	C8-S	8 x 6.1 (arc min)	12.6 x 9.7 (arc min)
	C9.25-S	6.9 x 5.3 (arc min)	11 x 8.4 (arc min)

\* Field of view calculated using SBIG ST 237 CCD camera with 4.7mm x 3.6mm chip.

Table 7-3

## Auto Guiding

The Advanced GT telescope has a designated auto guiding port for use with a CCD autoguider. The diagram below may be useful when connecting the CCD camera cable to the telescope and calibrating the autoguider. Note that the four outputs are active-low, with internal pull-ups and are capable of sinking 25 mA DC.

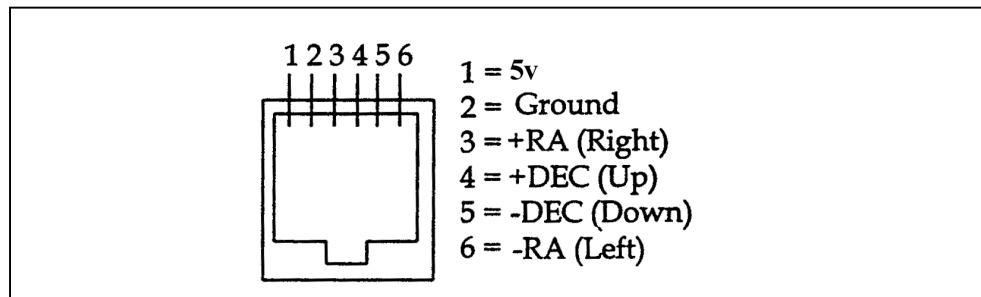

# **Telescope Maintenance**

While your telescope requires little maintenance, there are a few things to remember that will ensure your telescope performs at its best.

## Care and Cleaning of the Optics

Occasionally, dust and/or moisture may build up on the corrector plate of your telescope. Special care should be taken when cleaning any instrument so as not to damage the optics.

If dust has built up on the corrector plate, remove it with a brush (made of camel's hair) or a can of pressurized air. Spray at an angle to the lens for approximately two to four seconds. Then, use an optical cleaning solution and white tissue paper to remove any remaining debris. Apply the solution to the tissue and then apply the tissue paper to the lens. Low pressure strokes should go from the center of the corrector to the outer portion. **Do NOT rub in circles!**

You can use a commercially made lens cleaner or mix your own. A good cleaning solution is isopropyl alcohol mixed with distilled water. The solution should be 60% isopropyl alcohol and 40% distilled water. Or, liquid dish soap diluted with water (a couple of drops per one quart of water) can be used.

Occasionally, you may experience dew build-up on the corrector plate of your telescope during an observing session. If you want to continue observing, the dew must be removed, either with a hair dryer (on low setting) or by pointing the telescope at the ground until the dew has evaporated.

If moisture condenses on the inside of the corrector, remove the accessories from the rear cell of the telescope. Place the telescope in a dust-free environment and point it down. This will remove the moisture from the telescope tube.

To minimize the need to clean your telescope, replace all lens covers once you have finished using it. Since the rear cell is NOT sealed, the cover should be placed over the opening when not in use. This will prevent contaminants from entering the optical tube.

Internal adjustments and cleaning should be done only by the Celestron repair department. If your telescope is in need of internal cleaning, please call the factory for a return authorization number and price quote.

## Collimation

The optical performance of your telescope is directly related to its collimation, that is the alignment of its optical system. Your telescope was collimated at the factory after it was completely assembled. However, if the telescope is dropped or jarred severely during transport, it may have to be collimated. The only optical element that may need to be adjusted, or is possible, is the tilt of the secondary mirror.

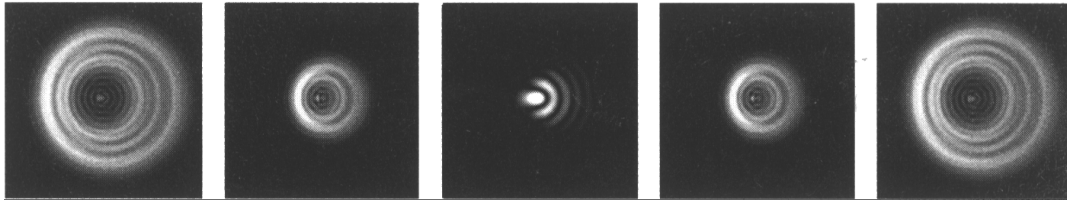

**Figure 8-1**  
The three collimation screws are located on the front of the secondary mirror housing.

To check the collimation of your telescope you will need a light source. A bright star near the zenith is ideal since there is a minimal amount of atmospheric distortion. Make sure that tracking is on so that you won't have to manually track the star. Or, if you do not want to power up your telescope, you can use Polaris. Its position relative to the celestial pole means that it moves very little thus eliminating the need to manually track it.

Before you begin the collimation process, be sure that your telescope is in thermal equilibrium with the surroundings. Allow 45 minutes for the telescope to reach equilibrium if you move it between large temperature extremes.

To verify collimation, view a star near the zenith. Use a medium to high power ocular — 12mm to 6mm focal length. It is important to center a star in the center of the field to judge collimation. Slowly cross in and out of focus and judge the symmetry of the star. If you see a systematic skewing of the star to one side, then re-collimation is needed.

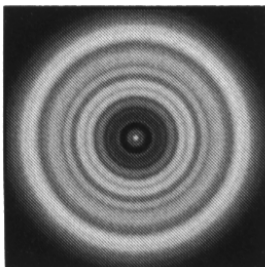

**Figure 8-2 -- Even though the star pattern appears the same on both sides of focus, they are asymmetric. The dark obstruction is skewed off to the left side of the diffraction pattern indicating poor collimation.**

To accomplish this, you need to tighten the secondary collimation screw(s) that move the star across the field toward the direction of the skewed light. These screws are located in the secondary mirror holder (see figure 8-1). Make only small 1/6 to 1/8 adjustments to the collimation screws and re-center the star by moving the scope before making any improvements or before making further adjustments.

To make collimation a simple procedure, follow these easy steps:

1. While looking through a medium to high power eyepiece, de-focus a bright star until a ring pattern with a dark shadow appears (see figure 8-2). Center the de-focused star and notice in which direction the central shadow is skewed.
2. Place your finger along the edge of the front cell of the telescope (be careful not to touch the corrector plate), pointing towards the collimation screws. The shadow of your finger should be visible when looking into the eyepiece. Rotate your finger around the tube edge until its shadow is seen closest to the narrowest portion of the rings (i.e. the same direction in which the central shadow is skewed).
3. Locate the collimation screw closest to where your finger is positioned. This will be the collimation screw you will need to adjust first. (If your finger is positioned exactly between two of the collimation screws, then you will need to adjust the screw opposite where your finger is located).
4. Use the hand control buttons to move the de-focused star image to the edge of the field of view, in the same direction that the central obstruction of the star image is skewed.
5. While looking through the eyepiece, use an Allen wrench to turn the collimation screw you located in step 2 and 3. Usually a tenth of a turn is enough to notice a change in collimation. If the star image moves out of the field of view in the direction that the central shadow is skewed, than you are turning the collimation screw the wrong way. Turn the screw in the opposite direction, so that the star image is moving towards the center of the field of view.
6. If while turning you notice that the screws get very loose, then simply tighten the other two screws by the same amount. Conversely, if the collimation screw gets too tight, then loosen the other two screws by the same amount.
7. Once the star image is in the center of the field of view, check to see if the rings are concentric. If the central obstruction is still skewed in the same direction, then continue turning the screw(s) in the same direction. If you find that the ring pattern is skewed in a different direction, than simply repeat steps 2 through 6 as described above for the new direction.



**Figure 8-3**  
A collimated telescope should appear symmetrical with the central obstruction centered in the star's diffraction pattern.

Perfect collimation will yield a star image very symmetrical just inside and outside of focus. In addition, perfect collimation delivers the optimal optical performance specifications that your telescope is built to achieve.

If seeing (i.e., air steadiness) is turbulent, collimation is difficult to judge. Wait until a better night if it is turbulent or aim to a steadier part of the sky. A steadier part of the sky is judged by steady versus twinkling stars.



## CELESTRON Optional Accessories

You will find that additional accessories enhance your viewing pleasure and expand the usefulness of your telescope. For ease of reference, all the accessories are listed in alphabetical order.

**Adapter AC (#18773)** - Allow DC (battery powered) telescopes to be converted for use with 120 volt AC power.

**Auxiliary Port Accessory (#93965)** - This accessory plugs into the auxiliary port of the telescopes control panel to provide additional ports for accessories like the CN-16 GPS as well as a PC programming port.

**Barlow Lens** - A Barlow lens is a negative lens that increases the focal length of a telescope. Used with any eyepiece, it doubles the magnification of that eyepiece. Celestron offers two Barlow lens in the 1-1/4" size. The 2x Ultima Barlow (#93506) is a compact triplet design that is fully multicoated for maximum light transmission and parfocal when used with the Ultima eyepieces. The OMNI Barlow (#93326) is a compact achromatic Barlow lens that is under three inches long and weighs only 4 oz. It works very well with all Celestron eyepieces.

**Erect Image Diagonal (#94112-A)** - This accessory is an Amici prism arrangement that allows you to look into the telescope at a 45° angle with images that are oriented properly (upright and correct from left-to-right). It is useful for daytime, terrestrial viewing.

**Eyepieces** - Like telescopes, eyepieces come in a variety of designs. Each design has its own advantages and disadvantages. For the 1-1/4" barrel diameter there are four different eyepiece designs available.

- **OMNI Plössl** - Plössl eyepieces have a 4-element lens designed for low-to-high power observing. The Plössls offer razor sharp views across the entire field, even at the edges! In the 1-1/4" barrel diameter, they are available in the following focal lengths: 4mm, 6mm, 9mm, 12.5mm, 15mm, 20mm, 25mm, 32mm and 40mm.
- **X-Cel** - This 6 element design allows each X-Cel Eyepiece to have 20mm of eye relief, 55° field of view and more than 25mm of lens aperture (even with the 2.3mm). In order to maintain razor sharp, color corrected images across its 55° field of view, extra-low dispersion glass is used for the most highly curved optical elements. The excellent refractive properties of these high grade optical elements, make the X-Cel line especially well suited for high magnification planetary viewing where sharp, color-free views are most appreciated. X-Cel eyepiece come in the following focal lengths: 2.3mm, 5mm, 8mm, 10mm, 12.5mm, 18mm, 21mm, 25mm.
- **Ultima** - Ultima is our 5-element, wide field eyepiece design. In the 1-1/4" barrel diameter, they are available in the following focal lengths: 5mm, 7.5mm, 10mm, 12.5mm, 18mm, 30mm, 35mm, and 42mm. These eyepieces are all parfocal. The 35mm Ultima gives the widest possible field of view with a 1-1/4" diagonal.
- **Axiom** - As an extension of the Ultima line, a new wide angle series is offered - called the Axiom series. All units are seven element designs and feature a 70° extra wide field of view (except the 50mm). All are fully multicoated and contain all the features of the Ultimas.



**Filters Sets, Eyepiece** - Celestron offers four convenient filter sets, which contain four different filters per set. Not only are these highly useful filter combinations, but they also offer an economical way to add versatility to your filter collection.

Series 1 - #94119-10

Orange, Light Blue, ND13%T, Polarizing (#s 21, 80A, #15, Polarizing)

Series 2 – #94119-20  
Deep Yellow, Red, Light Green, ND25% T (#s 12, 25, 56, 96ND-25)

Series 3 – #94119-30  
Light Red, Blue, Green, ND50% T (#s 23A, 38A, 58, 96ND-50)

Series 4 – #94119-40  
Yellow, Deep Yellow, Violet, Pale Blue (#s 8, 47, 82A, ND96-13)

**Flashlight, Night Vision - (#93588)** - Celestron's premium model for astronomy, using two red LED's to preserve night vision better than red filters or other devices. Brightness is adjustable. Operates on a single 9 volt battery (included).

**CN16 GPS Accessory (#93963)** - Plug in this 16-channel GPS module into your telescopes drive base port to link up and automatically download information from one of many global positioning satellites. Controlled with the computerized hand control, the CN-16 will greatly improve the accuracy of your star alignments.

**CN16 GPS Bracket (#93964)** – Support your CN-16 GPS accessory with this bracket and strap combination that securely wraps around any of the tripod legs and holds the GPS module in place .

**Light Pollution Reduction (LPR) Filters** - These filters are designed to enhance your views of deep sky astronomical objects when viewed from urban areas. LPR Filters selectively reduce the transmission of certain wavelengths of light, specifically those produced by artificial lights. This includes mercury and high and low pressure sodium vapor lights. In addition, they also block unwanted natural light (sky glow) caused by neutral oxygen emission in our atmosphere. Celestron offers a model for 1-1/4" eyepieces (#94126A) and a model that attaches to the rear cell ahead of the star diagonal and visual back (#94127A).



**Micro Guide Eyepiece (#94171)** - This multipurpose 12.5mm illuminated reticle can be used for guiding deep-sky astrophotos, measuring position angles, angular separations, and more. The laser etched reticle provides razor sharp lines and the variable brightness illuminator is completely cordless. The micro guide eyepiece produces 163 power with the C8-S and 188 power with the C9.25-S.

**Moon Filter (#94119-A)** - Celestron's Moon Filter is an economical eyepiece filter for reducing the brightness of the moon and improving contrast, so greater detail can be observed on the lunar surface. The clear aperture is 21mm and the transmission is about 18%.

**Motor Drive, Single Axis (#93518)** – This motor drive is a single axis (R.A.), DC motor drive. It is powered by four D-cell batteries (not included). 2x and 4x sidereal speeds are available through the included hand controller. For non-computerized Advanced Series Mounts.

**Motor Drive, Dual Axis (#93523)** - This dual axis motor drive, with drive corrector capabilities, are designed for Celestron's Advanced CG-5 mounts. They precisely control the telescope's tracking speed during long, timed exposures of celestial objects, producing the best possible image sharpness. Four speeds are available—1x (sidereal), 2x for guiding, 4x, and 8x for centering. These precision, state-of-the-art DC motor drives operate from 4 D-cell batteries (not included). The hand controller module is very compact and fits easily in the palm of your hand. Motors for both axes are included, along with brackets, clutches and hardware. For non-computerized Advanced Series Mounts.

**Polarizing Filter Set (#93608)** - The polarizing filter set limits the transmission of light to a specific plane, thus increasing contrast between various objects. This is used primarily for terrestrial, lunar and planetary observing.

**Polar Axis Finderscope (#94220)** – This useful accessory speeds accurate polar alignment by providing a means of visually aligning your German equatorial mount with Polaris and true north. As a result, you can spend more time observing and less time setting up. The finderscope has an easy to use cross hair reticle.

**PowerTank (#18774)** – 12v 7Amp hour rechargeable power supply. Comes with two 12v output cigarette outlets, built-in red flash light , Halogen emergency spotlight. Switchable 110v/220v AC adapter and cigarette lighter adapter included.



**Radial Guider (#94176)** - The Celestron Radial Guider<sup>®</sup> is specifically designed for use in prime focus, deep sky astrophotography and takes the place of the T-Adapter. This device allows you to photograph and guide simultaneously through the optical tube assembly of your telescope. This type of guiding produces the best results since what you see through the guiding eyepiece is exactly reproduced on the processed film. The Radial Guider is a “T”-shaped assembly that attaches to the rear cell of the telescope. As light from the telescope enters the guider, most passes straight through to the camera. A small portion, however, is diverted by a prism at an adjustable angle up to the guiding eyepiece. This guider has two features not found on other off-axis guiders; first, the prism and eyepiece housing rotate independently of the camera orientation making the acquisition of a guide star quite easy. Second, the prism angle is tunable allowing you to look at guide stars on-axis. This accessory works especially well with the Reducer/Corrector.



**Reducer/Corrector (#94175)** - This lens reduces the focal length of the telescope by 37%, making your C8-S a 1280mm f/6.3 instrument. In addition, this unique lens also corrects inherent aberrations to produce crisp images all the way across the field when used visually. When used photographically, there is some vignetting that produces a 26mm circular image on the processed film. It also increases the field of view significantly and is ideal for wide-field, deep-space viewing. It is also perfect for beginning prime focus, long-exposure astro photography when used with the radial guider. It makes guiding easier and exposures much shorter.



**RS-232 Cable (#93920)** – Allows your Advanced Series telescope to be controlled using a laptop computer or PC. Once connected, the telescope can be controlled using popular astronomy software programs.

**Sky Maps (#93722)** - Celestron Sky Maps are the ideal teaching guide for learning the night sky. You wouldn't set off on a road trip without a road map, and you don't need to try to navigate the night sky without a map either. Even if you already know your way around the major constellations, these maps can help you locate all kinds of fascinating objects.

**Skylight Filter (#93621)** - The Skylight Filter is used on the Celestron telescope as a dust seal. The filter threads onto the rear cell of your telescope. All other accessories, both visual and photographic (with the exception of Barlow lenses), thread onto the skylight filter. The light loss caused by this filter is minimal.

**Solar Filter** - The Baader AstroSolar<sup>®</sup> filter is a safe and durable filter that covers the front opening of the telescope. View sunspots and other solar features using this double-sided metal coated filter for uniform density and good color balance across the entire field. The Sun offers constant changes and will keep your observing interesting and fun. Celestron offers filters for the C5-S (#94139) and C8-S (#94162).

**T-Adapter (#93633-A)** - T-Adapter (with additional T-Ring) allows you to attach your SLR camera to the rear cell of your Celestron telescope. This turns your telescope into a high power telephoto lens perfect for terrestrial photography and short exposure lunar and filtered solar photography.

**T-Ring** - The T-Ring couples your 35mm SLR camera body to the T-Adapter, radial guider, or tele-extender. This accessory is mandatory if you want to do photography through the telescope. Each camera make (i.e., Minolta, Nikon, Pentax, etc.) has its own unique mount and therefore, its own T-Ring. Celestron has 8 different models for 35mm cameras.

**Tele-Extender, Deluxe (#93643)** - The tele-extender is a hollow tube that allows you to attach a camera to the telescope when the eyepiece is installed. This accessory is used for eyepiece projection photography which allows you to capture very high power views of the Sun, Moon, and planets on film. The tele-extender fits over the eyepiece onto the visual back. This tele-extender works with eyepieces that have large housings, like the Celestron Ultima series.

**A full description of all Celestron accessories can be found in the Celestron Accessory Catalog (#93685)**

## Appendix A – Technical Specifications

Advanced Series	11071/11072	11025/11026	11045/11046
	C5-S	C8-S	C9.25-S
<b>Specifications:</b>			
<b>Optical Design</b>	127mm(5") Schmidt-Cassegrain	203mm (8") Schmidt-Cassegrain	235mm (9.25") Schmidt-Cassegrain
<b>Focal Length</b>	1250mm F/10	2032mm F/10	2350mm F/10
<b>Finderscope</b>	6x30	6x30	6x30
<b>Mount</b>	CG-5 Equatorial	CG-5 Equatorial	CG-5 Equatorial
<b>Eyepiece</b>	25mm Plossl (50x)	25mm Plossl (81x)	25mm Plossl (94x)
<b>Star Diagonal</b>	1.25"	1.25"	1.25"
<b>Accessory tray</b>	Yes	Yes	Yes
<b>Tripod</b>	2" Stainless Steel	2" Stainless Steel	2" Stainless Steel
<b>Technical Specs</b>			
<b>Highest Useful Magnification</b>	300x	480x	555x
<b>Lowest Useful Magnification</b>	18x	29x	34x
<b>Limiting Stellar Magnitude</b>	13	14	14.4
<b>Resolution: Rayleigh</b>	1.1 arc seconds	.68 arc seconds	.59 arc seconds
<b>Dawes Limit</b>	.91 arc seconds	.57 arc seconds	.49 arc seconds
<b>Photographic Resolution</b>	200 line/mm	200 line/mm	200 line/mm
<b>Light Gathering Power</b>	329x unaided eye	843x unaided eye	1127x unaided eye
<b>Field of View: standard eyepiece</b>	1°	.64°	.55°
<b>Linear FOV (@1000 yds)</b>	52.5 ft.	33.6 ft.	29 ft.
<b>Optical Coatings - Standard</b>	Starbright Coating	Starbright Coating	Starbright Coating
<b>Secondary Mirror Obstruction</b>	1.75"	2.7"	3.35"
<b>by Area</b>	12%	11%	13%
<b>by Diameter</b>	35%	34%	36%
<b>Optical tube length</b>	14 inches	17 inches	22 inches
<b>Telescope Weight</b>	48 lbs	54.5 lbs	73 lbs

Advanced GT	
<b>Additional Specifications</b>	
<b>Hand Control</b>	Double line, 16 character Liquid Crystal Display; 19 fiber optic backlit LED buttons
<b>Motor: Type</b>	DC Servo motors with encoders, both axes
<b>Max Slew Speed</b>	3°/second
<b>Software Precision</b>	24bit, 0.08 arcsec calculation
<b>Hand Control Ports</b>	RS-232 communication port on hand control
<b>Motor Ports</b>	Aux Port, Autoguide Ports
<b>Tracking Rates</b>	Sidereal, Solar and Lunar
<b>Tracking Modes</b>	EQ North & EQ South
<b>Alignment Procedures</b>	AutoAlign, 3-Star Alignment, Quick Align, Last Align
<b>Database</b>	40,000+ objects, 400 user defined programmable objects. Enhanced information on over 200 objects
<b>Complete Revised NGC Catalog</b>	7,840
<b>Complete Messier Catalog</b>	110
<b>Complete IC Catalog</b>	5,386
<b>Complete Caldwell</b>	109
<b>Abell Galaxies</b>	2,712
<b>Solar System objects</b>	9
<b>Famous Asterisms</b>	20
<b>Selected CCD Imaging Objects</b>	25
<b>Selected SAO Stars</b>	29,500
<b>Total Object Database</b>	45,492

## Appendix B - Glossary of Terms

### A-

Absolute magnitude	The apparent magnitude that a star would have if it were observed from a standard distance of 10 parsecs, or 32.6 light-years. The absolute magnitude of the Sun is 4.8. at a distance of 10 parsecs, it would just be visible on Earth on a clear moonless night away from surface light.
Airy disk	The apparent size of a star's disk produced even by a perfect optical system. Since the star can never be focused perfectly, 84 per cent of the light will concentrate into a single disk, and 16 per cent into a system of surrounding rings.
Alt-Azimuth Mounting	A telescope mounting using two independent rotation axis allowing movement of the instrument in Altitude and Azimuth.
Altitude	In astronomy, the altitude of a celestial object is its Angular Distance above or below the celestial horizon.
Aperture	the diameter of a telescope's primary lens or mirror; the larger the aperture, the greater the telescope's light-gathering power.
Apparent Magnitude	A measure of the relative brightness of a star or other celestial object as perceived by an observer on Earth.
Arcminute	A unit of angular size equal to 1/60 of a degree.
Arcsecond	A unit of angular size equal to 1/3,600 of a degree (or 1/60 of an arcminute).
Asterism	A small unofficial grouping of stars in the night sky.
Asteroid	A small, rocky body that orbits a star.
Astrology	The pseudoscientific belief that the positions of stars and planets exert an influence on human affairs; astrology has nothing in common with astronomy.
Astronomical unit (AU)	The distance between the Earth and the Sun. It is equal to 149,597,900 km., usually rounded off to 150,000,000 km.
Aurora	The emission of light when charged particles from the solar wind slams into and excites atoms and molecules in a planet's upper atmosphere.
Azimuth	The angular distance of an object eastwards along the horizon, measured from due north, between the astronomical meridian (the vertical line passing through the center of the sky and the north and south points on the horizon) and the vertical line containing the celestial body whose position is to be measured. .

### B -

Binary Stars	Binary (Double) stars are pairs of stars that, because of their mutual gravitational attraction, orbit around a common Center of Mass. If a group of three or more stars revolve around one another, it is called a multiple system. It is believed that approximately 50 percent of all stars belong to binary or multiple systems. Systems with individual components that can be seen separately by a telescope are called visual binaries or visual multiples. The nearest "star" to our solar system, Alpha Centauri, is actually our nearest example of a multiple star system, it consists of three stars, two very similar to our Sun and one dim, small, red star orbiting around one another.
--------------	---------------------------------------------------------------------------------------------------------------------------------------------------------------------------------------------------------------------------------------------------------------------------------------------------------------------------------------------------------------------------------------------------------------------------------------------------------------------------------------------------------------------------------------------------------------------------------------------------------------------------------------------------------------------------------------------------------

### C -

Celestial Equator	The projection of the Earth's equator on to the celestial sphere. It divides the sky into two equal hemispheres.
Celestial pole	The imaginary projection of Earth's rotational axis north or south pole onto the celestial sphere.
Celestial Sphere	An imaginary sphere surrounding the Earth, concentric with the Earth's center.
Collimation	The act of putting a telescope's optics into perfect alignment.

### D -

Declination (DEC)	The angular distance of a celestial body north or south of the celestial equator. It may be said to correspond to latitude on the surface of the Earth.
-------------------	---------------------------------------------------------------------------------------------------------------------------------------------------------

### E -

Ecliptic	The projection of the Earth's orbit on to the celestial sphere. It may also be defined as "the apparent yearly path of the Sun against the stars".
Equatorial mount	A telescope mounting in which the instrument is set upon an axis which is parallel to the axis of the Earth; the angle of the axis must be equal to the observer's latitude.

### F -

Focal length	The distance between a lens (or mirror) and the point at which the image of an object at infinity is brought to focus. The focal length divided by the aperture of the mirror or lens is termed the focal ratio.
--------------	------------------------------------------------------------------------------------------------------------------------------------------------------------------------------------------------------------------

<b>J -</b> Jovian Planets	Any of the four gas giant planets that are at a greater distance from the sun than the terrestrial planets.
<b>K -</b> Kuiper Belt	A region beyond the orbit of Neptune extending to about 1000 AU which is a source of many short period comets.
<b>L -</b> Light-Year (LY)	A light-year is the distance light traverses in a vacuum in one year at the speed of 299,792 km/ sec. With 31,557,600 seconds in a year, the light-year equals a distance of 9.46 X 1 trillion km (5.87 X 1 trillion mi).
<b>M -</b> Magnitude	Magnitude is a measure of the brightness of a celestial body. The brightest stars are assigned magnitude 1 and those increasingly fainter from 2 down to magnitude 5. The faintest star that can be seen without a telescope is about magnitude 6. Each magnitude step corresponds to a ratio of 2.5 in brightness. Thus a star of magnitude 1 is 2.5 times brighter than a star of magnitude 2, and 100 times brighter than a magnitude 5 star. The brightest star, Sirius, has an apparent magnitude of -1.6, the full moon is -12.7, and the Sun's brightness, expressed on a magnitude scale, is -26.78. The zero point of the apparent magnitude scale is arbitrary.
Meridian	A reference line in the sky that starts at the North celestial pole and ends at the South celestial pole and passes through the zenith. If you are facing South, the meridian starts from your Southern horizon and passes directly overhead to the North celestial pole.
Messier	A French astronomer in the late 1700's who was primarily looking for comets. Comets are hazy diffuse objects and so Messier cataloged objects that were not comets to help his search. This catalog became the Messier Catalog, M1 through M110.
<b>N -</b> Nebula	Interstellar cloud of gas and dust. Also refers to any celestial object that has a cloudy appearance.
North Celestial Pole	The point in the Northern hemisphere around which all the stars appear to rotate. This is caused by the fact that the Earth is rotating on an axis that passes through the North and South celestial poles. The star Polaris lies less than a degree from this point and is therefore referred to as the "Pole Star".
Nova	Although Latin for "new" it denotes a star that suddenly becomes explosively bright at the end of its life cycle.
<b>O -</b> Open Cluster	One of the groupings of stars that are concentrated along the plane of the Milky Way. Most have an asymmetrical appearance and are loosely assembled. They contain from a dozen to many hundreds of stars.
<b>P -</b> Parallax	Parallax is the difference in the apparent position of an object against a background when viewed by an observer from two different locations. These positions and the actual position of the object form a triangle from which the apex angle (the parallax) and the distance of the object can be determined if the length of the baseline between the observing positions is known and the angular direction of the object from each position at the ends of the baseline has been measured. The traditional method in astronomy of determining the distance to a celestial object is to measure its parallax.
Parfocal	Refers to a group of eyepieces that all require the same distance from the focal plane of the telescope to be in focus. This means when you focus one parfocal eyepiece all the other parfocal eyepieces, in a particular line of eyepieces, will be in focus.
Parsec	The distance at which a star would show parallax of one second of arc. It is equal to 3.26 light-years, 206,265 astronomical units, or 30,8000,000,000,000 km. (Apart from the Sun, no star lies within one parsec of us.)
Point Source	An object which cannot be resolved into an image because it is too far away or too small is considered a point source. A planet is far away but it can be resolved as a disk. Most stars cannot be resolved as disks, they are too far away.
<b>R -</b> Reflector	A telescope in which the light is collected by means of a mirror.
Resolution	The minimum detectable angle an optical system can detect. Because of diffraction, there is a limit to the minimum angle, resolution. The larger the aperture, the better the resolution.
Right Ascension: (RA)	The angular distance of a celestial object measured in hours, minutes, and seconds along the Celestial Equator eastward from the Vernal Equinox.
<b>S -</b> Schmidt Telescope	Rated the most important advance in optics in 200 years, the Schmidt telescope combines the best features of the refractor and reflector for photographic purposes. It was invented in 1930 by Bernhard Voldemar Schmidt (1879-1935).
Sidereal Rate	This is the angular speed at which the Earth is rotating. Telescope tracking motors drive the

telescope at this rate. The rate is 15 arc seconds per second or 15 degrees per hour.

**T -**

Terminator

The boundary line between the light and dark portion of the moon or a planet.

**U -**

Universe

The totality of astronomical things, events, relations and energies capable of being described objectively.

**V -**

Variable Star

A star whose brightness varies over time due to either inherent properties of the star or something eclipsing or obscuring the brightness of the star.

**W -**

Waning Moon

The period of the moon's cycle between full and new, when its illuminated portion is decreasing.

Waxing Moon

The period of the moon's cycle between new and full, when its illuminated portion is increasing.

**Z -**

Zenith

The point on the Celestial Sphere directly above the observer.

Zodiac

The zodiac is the portion of the Celestial Sphere that lies within 8 degrees on either side of the Ecliptic. The apparent paths of the Sun, the Moon, and the planets, with the exception of some portions of the path of Pluto, lie within this band. Twelve divisions, or signs, each 30 degrees in width, comprise the zodiac. These signs coincided with the zodiacal constellations about 2,000 years ago. Because of the Precession of the Earth's axis, the Vernal Equinox has moved westward by about 30 degrees since that time; the signs have moved with it and thus no longer coincide with the constellations.













## Appendix D - RS-232 Connection

You can control your telescope with a computer via the RS-232 port on the computerized hand control and using an optional RS-232 cable (#93920). Once connected, the telescope can be controlled using popular astronomy software programs.

### Communication Protocol:

The Advanced GT communicates at 9600 bits/sec, No parity and a stop bit. All angles are communicated with 16 bit angle and communicated using ASCII hexadecimal.

Description	PC Command ASCII	Hand Control Response	Notes
Echo	Kx	X#	Useful to check communication
Goto Azm-Alt	B12AB, 4000	#	10 characters sent. B=Command, 12AB=Azm, comma, 4000=Alt. If command conflicts with slew limits, there will be no action.
Goto Ra-Dec	R34AB, 12CE	#	Scope must be aligned. If command conflicts with slew limits, there will be no action.
Get Azm-Alt	Z	12AB, 4000#	10 characters returned, 12AB=Azm, comma, 4000=Alt, #
Get RA-Dec	E	34AB, 12CE#	Scope must be aligned
Cancel Goto	M	#	
Is Goto in Progress	L	0# or 1#	0=No, 1=Yes; "0" is ASCII character zero
Is Alignment Complete	J	0# or 1#	0=No, 1=Yes
<b>Commands below available on version 1.6 or later</b>			
HC version	V	22	Two bytes representing V2.2
Stop/Start Tracking	Tx x = 0 (Tracking off) x = 1 (Alt-Az on) x = 2 (EQ-N) x = 3 (EQ-S)	#	Alt-Az tracking requires alignment
32-bit goto RA-Dec	r34AB0500,12CE0500	#	
32-bit get RA-Dec	e	34AB0500,12CE0500#	The last two characters will always be zero.
<b>Commands below available on version 2.2 or later</b>			
32-bit goto Azm-Alt	b34AB0500,12CE0500	#	
32-bit get Azm-Alt	z	34AB0500,12CE0500#	The last two characters will always be zero.

The cable required to interface to the telescope has an RS-232 male plug at one end and a 4-4 telephone jack at the other end. The wiring is as follows:

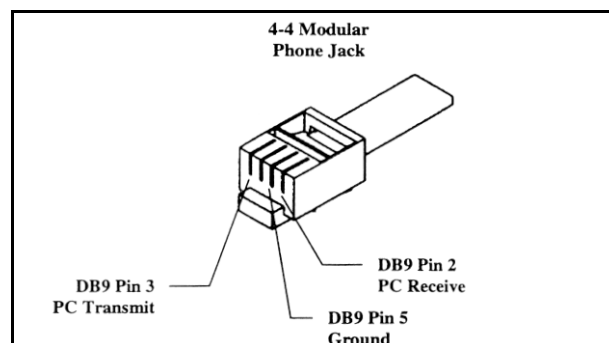

## Additional RS232 Commands

### **Send Any Track Rate Through RS232 To The Hand Control**

1. Multiply the desired tracking rate (arcseconds/second) by 4. Example: if the desired trackrate is 150 arcseconds/second, then TRACKRATE = 600
2. Separate TRACKRATE into two bytes, such that (TRACKRATE = TrackRateHigh\*256 + rackRateLow). Example: TrackRateHigh = 2 TrackRateLow = 88
3. To send a tracking rate, send the following 8 bytes:
  - a. **Positive Azm tracking:** 80, 3, 16, 6, TrackRateHigh, TrackRateLow, 0, 0
  - b. **Negative Azm tracking:** 80, 3, 16, 7, TrackRateHigh, TrackRateLow, 0, 0
  - c. **Positive Alt tracking:** 80, 3, 17, 6, TrackRateHigh, TrackRateLow, 0, 0
  - d. **Negative Alt tracking:** 80, 3, 17, 7, TrackRateHigh, TrackRateLow, 0, 0
4. The number 35 is returned from the handcontrol

### **Send A Slow-Goto Command Through RS232 To The Hand Control**

(note: Only valid for motorcontrol version 4.1 or greater)

1. Convert the angle position to a 24bit number. Example: if the desired position is 220°, then POSITION\_24BIT =  $(220/360)*2^{24} = 10,252,743$
2. Separate POSITION\_24BIT into three bytes such that (POSITION\_24BIT = PosHigh\*65536 + PosMed\*256 + PosLow). Exampe: PosHigh = 156, PosMed = 113, PosLow = 199
3. Send the following 8 bytes:
  - a. Azm Slow Goto: 80, 4, 16, 23, PosHigh, PosMed, PosLow, 0
  - b. Alt Slow Goto: 80, 4, 17, 23, PosHigh, PosMed, PosLow, 0
4. The number 35 is returned from the handcontrol

### **Reset The Position Of Azm Or Alt**

1. Convert the angle position to a 24bit number, same as Slow-Goto example.
2. Send the following 8 bytes:
  - a. Azm Set Position: 80, 4, 16, 4, PosHigh, PosMed, PosLow, 0
  - b. Alt Set Position: 80, 4, 17, 4, PosHigh, PosMed, PosLow, 0
3. The number 35 is returned from the handcontrol
4. Note: If using Motorcontrol version less than 4.1, then send:
  - a. Azm Set Position: 80, 3, 16, 4, PosHigh, PosMed, PosLow, 0
  - b. Alt Set Position: 80, 3, 17, 4, PosHigh, PosMed, PosLow, 0

# APPENDIX E – MAPS OF TIME ZONES

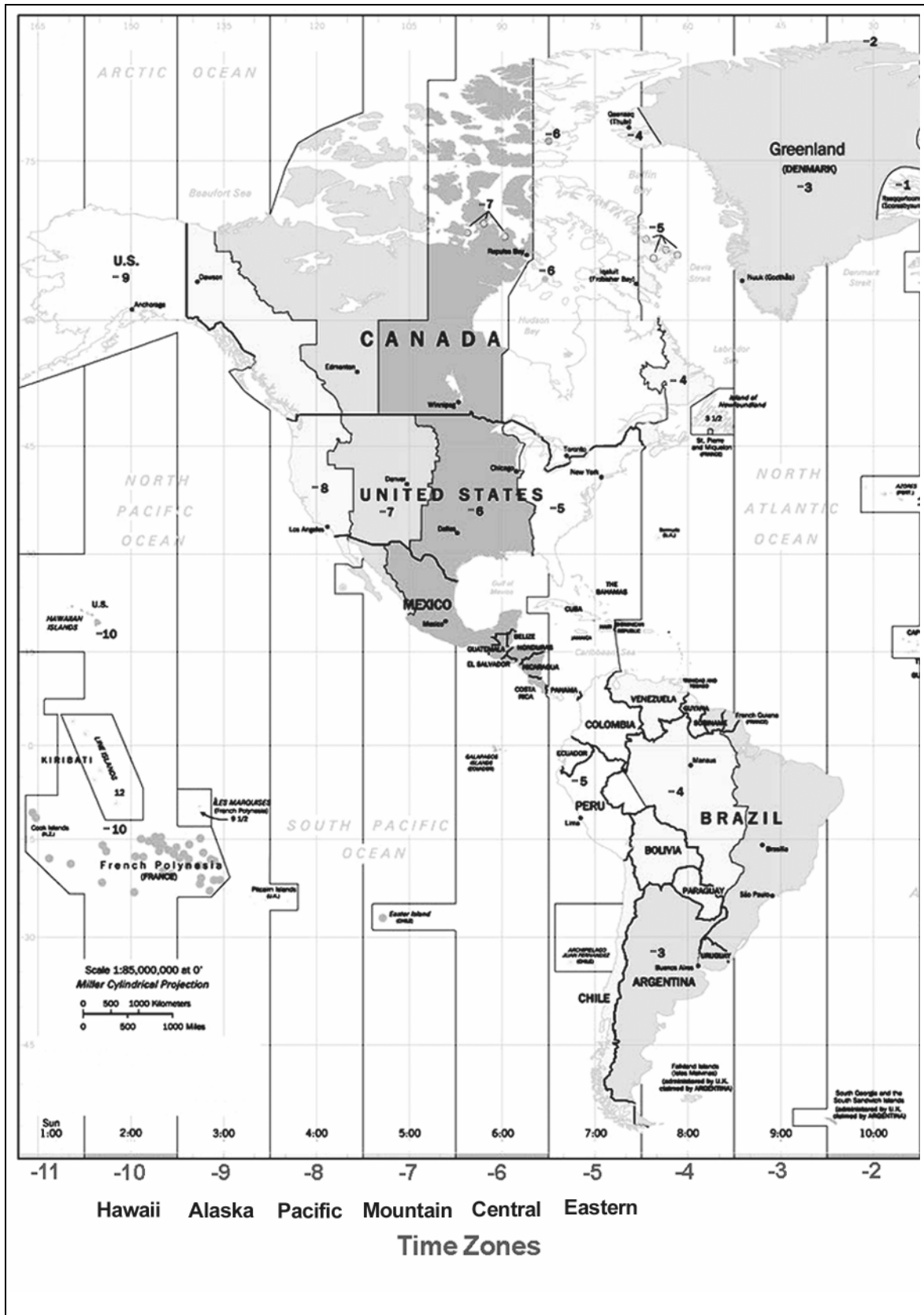

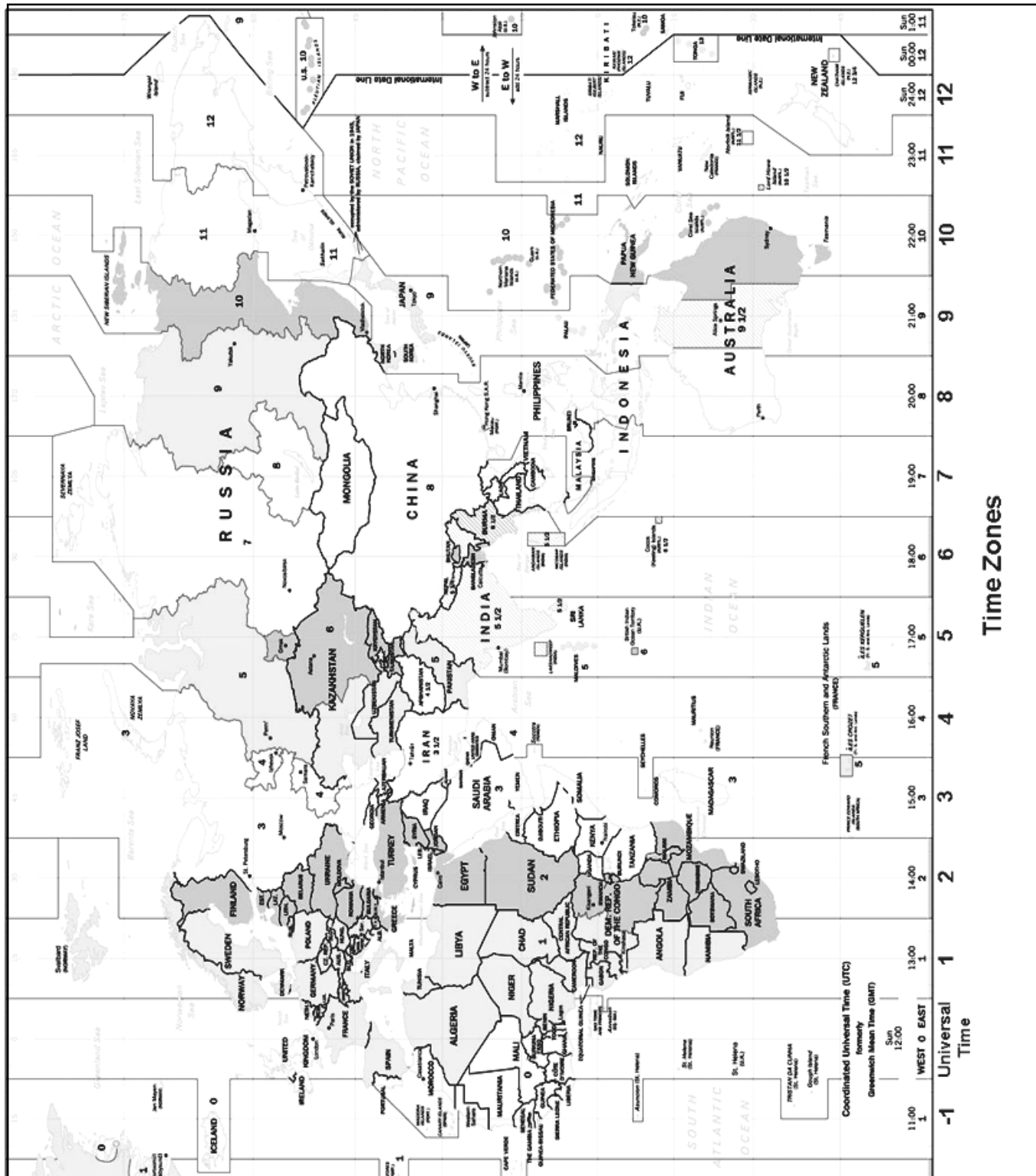



# January - February Sky

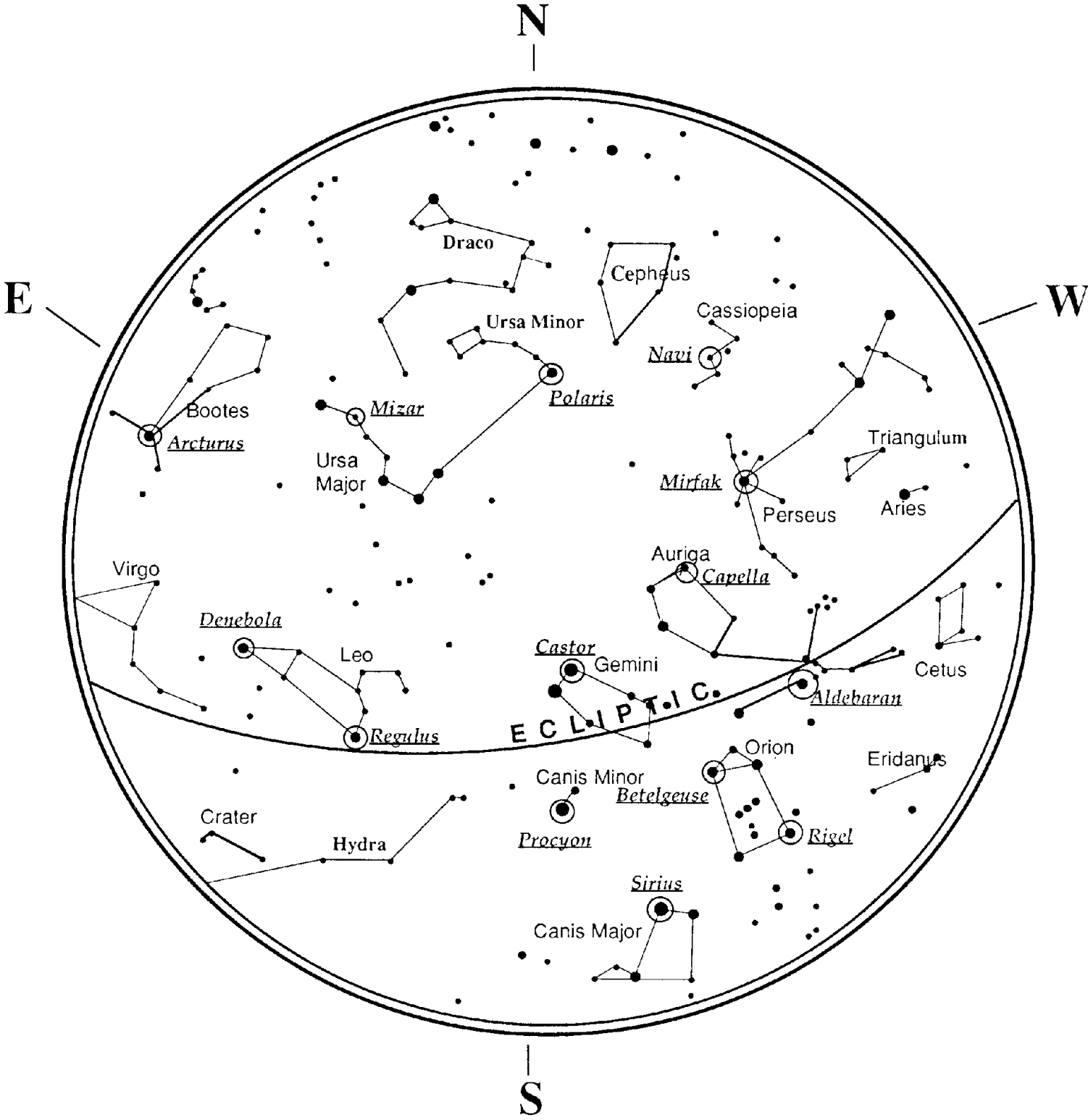

# March - April Sky

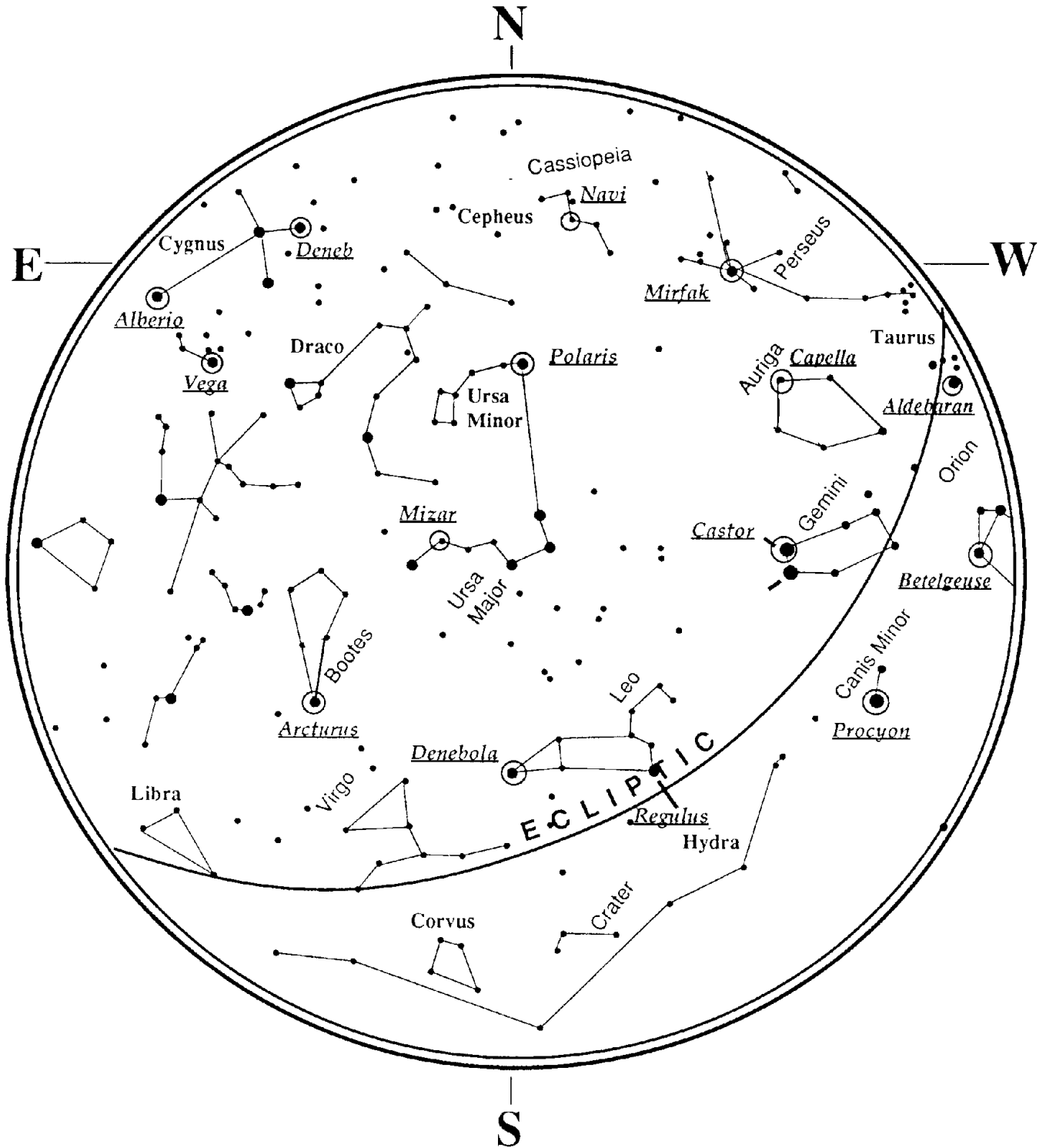

# May - June Sky

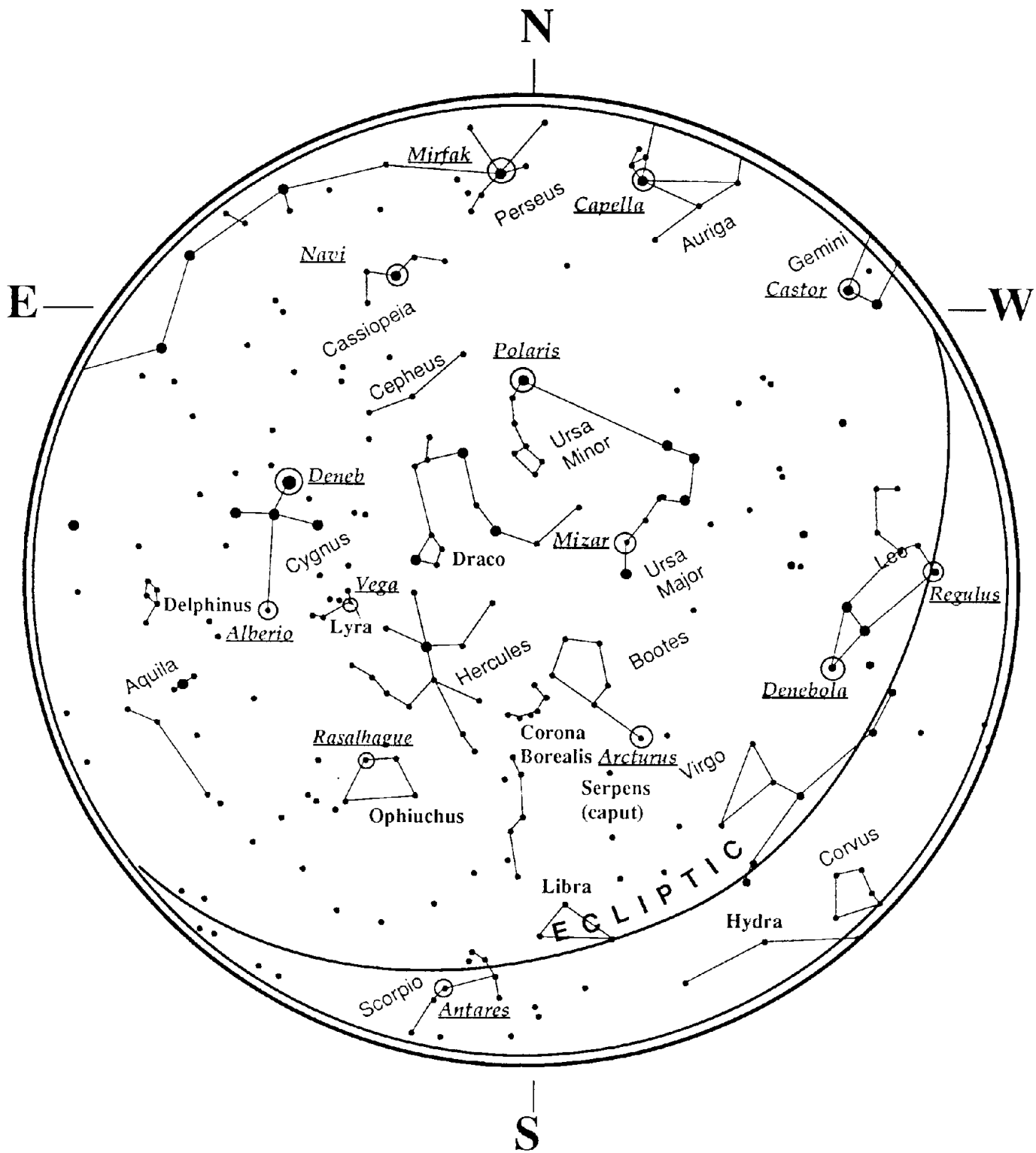

# July - August Sky

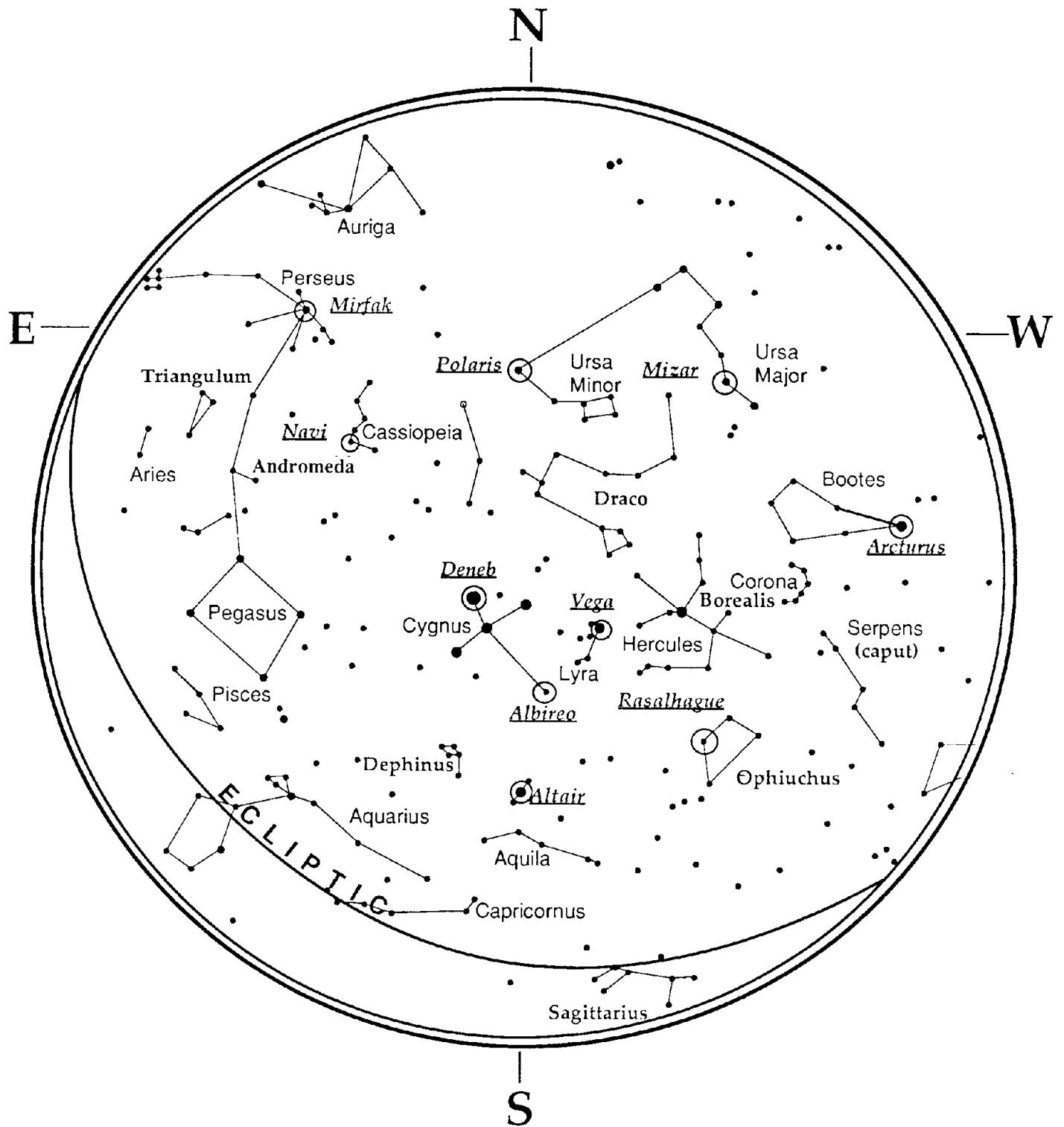

# September - October Sky

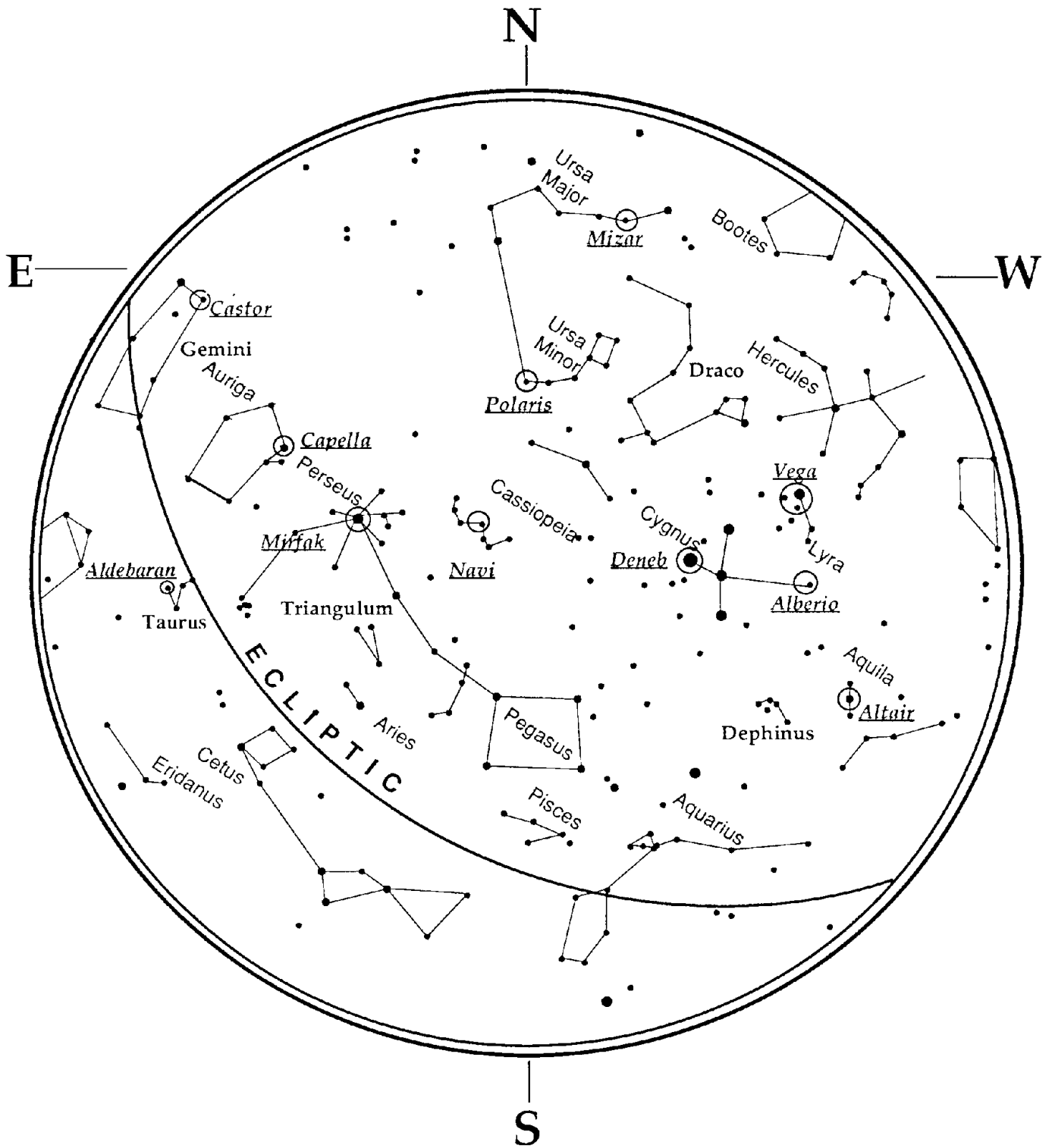

# November - December Sky

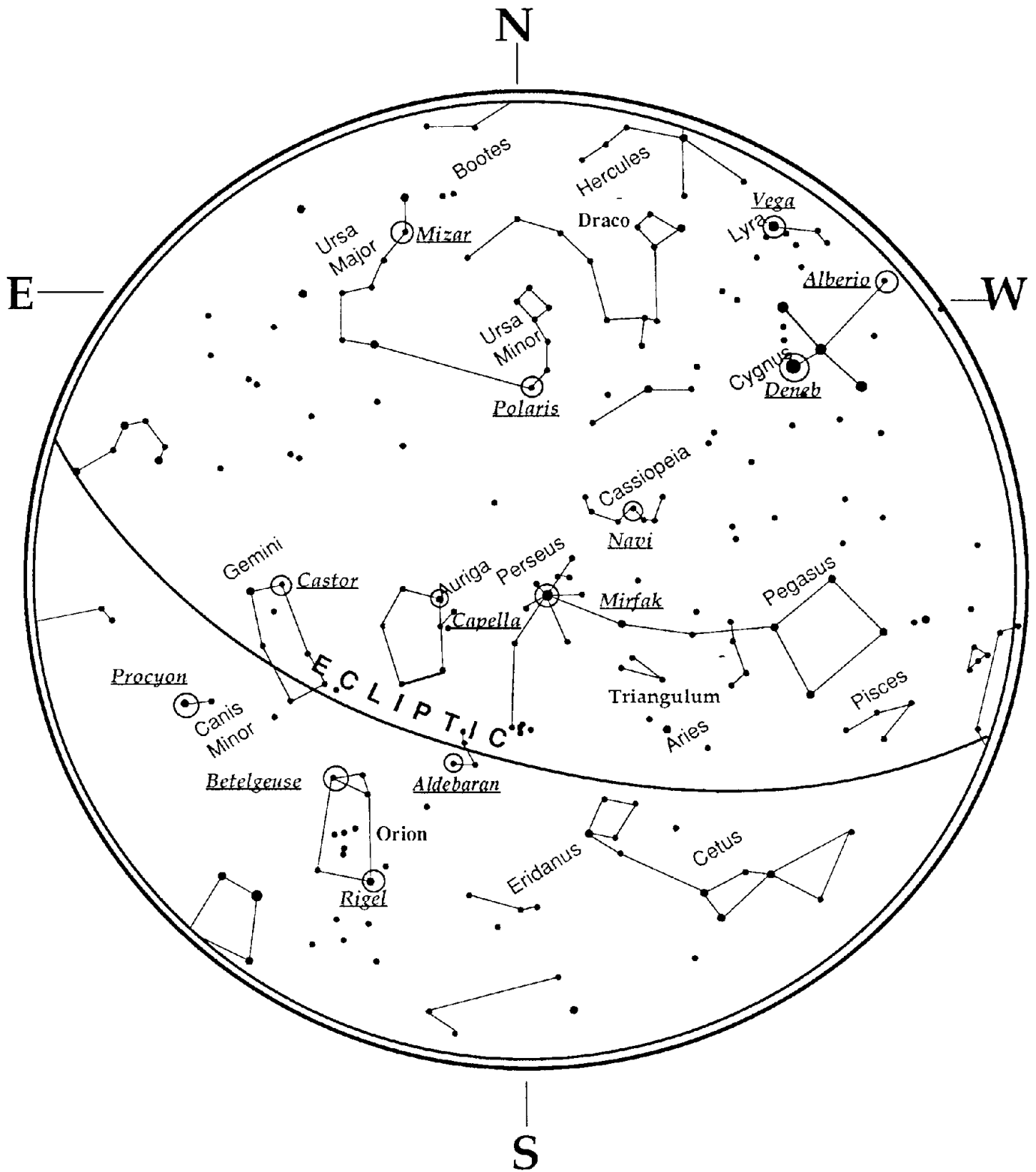

## CELESTRON TWO YEAR WARRANTY

- A. Celestron warrants this telescope to be free from defects in materials and workmanship for two years. Celestron will repair or replace such product or part thereof which, upon inspection by Celestron, is found to be defective in materials or workmanship. As a condition to the obligation of Celestron to repair or replace such product, the product must be returned to Celestron together with proof-of-purchase satisfactory to Celestron.
- B. The Proper Return Authorization Number must be obtained from Celestron in advance of return. Call Celestron at (310) 328-9560 to receive the number to be displayed on the outside of your shipping container.

All returns must be accompanied by a written statement setting forth the name, address, and daytime telephone number of the owner, together with a brief description of any claimed defects. Parts or product for which replacement is made shall become the property of Celestron.

**The customer shall be responsible for all costs of transportation and insurance, both to and from the factory of Celestron, and shall be required to prepay such costs.**

Celestron shall use reasonable efforts to repair or replace any telescope covered by this warranty within thirty days of receipt. In the event repair or replacement shall require more than thirty days, Celestron shall notify the customer accordingly. Celestron reserves the right to replace any product which has been discontinued from its product line with a new product of comparable value and function.

**This warranty shall be void and of no force of effect in the event a covered product has been modified in design or function, or subjected to abuse, misuse, mishandling or unauthorized repair. Further, product malfunction or deterioration due to normal wear is not covered by this warranty.**

CELESTRON DISCLAIMS ANY WARRANTIES, EXPRESS OR IMPLIED, WHETHER OF MERCHANTABILITY OF FITNESS FOR A PARTICULAR USE, EXCEPT AS EXPRESSLY SET FORTH HEREIN.

THE SOLE OBLIGATION OF CELESTRON UNDER THIS LIMITED WARRANTY SHALL BE TO REPAIR OR REPLACE THE COVERED PRODUCT, IN ACCORDANCE WITH THE TERMS SET FORTH HEREIN. CELESTRON EXPRESSLY DISCLAIMS ANY LOST PROFITS, GENERAL, SPECIAL, INDIRECT OR CONSEQUENTIAL DAMAGES WHICH MAY RESULT FROM BREACH OF ANY WARRANTY, OR ARISING OUT OF THE USE OR INABILITY TO USE ANY CELESTRON PRODUCT. ANY WARRANTIES WHICH ARE IMPLIED AND WHICH CANNOT BE DISCLAIMED SHALL BE LIMITED IN DURATION TO A TERM OF TWO YEARS FROM THE DATE OF ORIGINAL RETAIL PURCHASE.

Some states do not allow the exclusion or limitation of incidental or consequential damages or limitation on how long an implied warranty lasts, so the above limitations and exclusions may not apply to you.

This warranty gives you specific legal rights, and you may also have other rights which vary from state to state.

Celestron reserves the right to modify or discontinue, without prior notice to you, any model or style telescope.

If warranty problems arise, or if you need assistance in using your telescope contact:

**Celestron**  
Customer Service Department  
2835 Columbia Street  
Torrance, CA 90503 U.S.A.  
Tel. (310) 328-9560  
Fax. (310) 212-5835  
Monday-Friday 8AM-4PM PST

This warranty supersedes all other product warranties.

**NOTE: This warranty is valid to U.S.A. and Canadian customers who have purchased this product from an Authorized Celestron Dealer in the U.S.A. or Canada. Warranty outside the U.S.A. and Canada is valid only to customers who purchased from a Celestron Distributor or Authorized Celestron Dealer in the specific country and please contact them for any warranty service.**



Celestron  
2835 Columbia Street  
Torrance, CA 90503 U.S.A.  
Tel. (310) 328-9560  
Fax. (310) 212-5835  
Web site at <http://www.celestron.com>

Copyright 2003 Celestron  
All rights reserved.

(Products or instructions may change  
without notice or obligation.)

Item # 11025-INST  
\$10.00  
08-03



## Free Manuals Download Website

<http://myh66.com>

<http://usermanuals.us>

<http://www.somanuals.com>

<http://www.4manuals.cc>

<http://www.manual-lib.com>

<http://www.404manual.com>

<http://www.luxmanual.com>

<http://aubethermostatmanual.com>

Golf course search by state

<http://golfingnear.com>

Email search by domain

<http://emailbydomain.com>

Auto manuals search

<http://auto.somanuals.com>

TV manuals search

<http://tv.somanuals.com>