

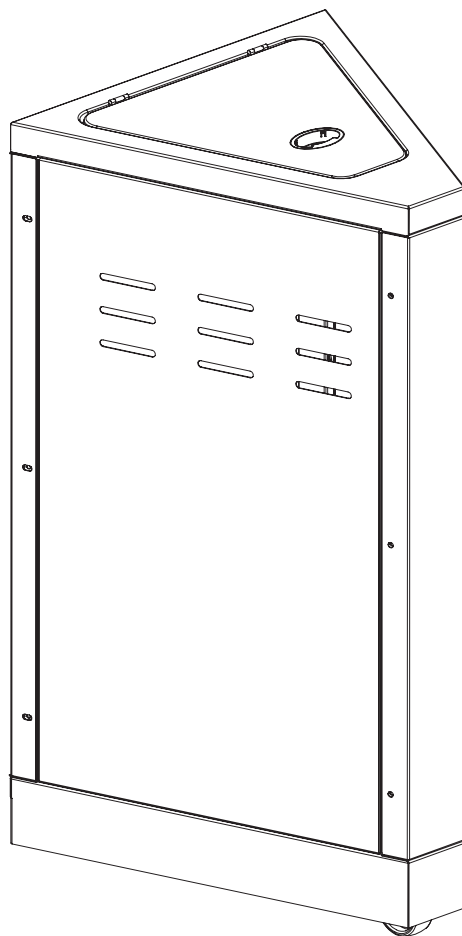

Corner Unit with built-in trash bag holder

SAFE USE, CARE AND ASSEMBLY MANUAL



1-YEAR LIMITED WARRANTY

85-1066-6 (A01001)

Read and save this manual for future reference. If pre-assembled, leave this manual with unit for consumer's future reference.

For product inquiries, parts, and warranty, please call

1-877-707-5463

TABLE OF CONTENTS

Warranty	ii
Important	1
Warnings	1
Care and Maintenance.	1
Parts List	2
Parts Diagram	2
Assembly Instructions	3-5

WARRANTY

One Year Limited Warranty

DO NOT RETURN TO STORE FOR PRODUCT INQUIRIES, PARTS OR WARRANTY. Please call toll-free 1-877-707-5463 for immediate customer service.

For Best Results

Remove all contents from packaging, and make sure all parts are present before attempting assembly. Tighten all bolts by hand first, then when the cart is fully assembled, go back and tighten.

One-year Limited Warranty

This Centro product carries a one-year limited warranty against defects in workmanship and materials, when assembled and used in accordance with the instructions in this manual. Trileaf Distribution requires proof of purchase to provide immediate service. Please keep your sales receipt with this manual.

This Limited Warranty is for replacement of defective parts only. Trileaf Distribution reserves the right to have its representatives inspect any product of part prior to honouring any warranty claim.

This limited warranty does not cover damage due to porcelain chipping, scratching of stainless steel surfaces, nor does it cover corrosion or discoloration due to misuse, lack of maintenance, fires, hostile environments, accidents, alterations, abuse or neglect, improper installation and failure to read and/or abide by any product warnings. Part failure due to lack of cleaning and maintenance, or use of improper cleaners will not be covered under this warranty. This limited warranty does not cover any damage sustained during removal and/or storage of this product. Should deterioration of parts occur to the degree of NON PERFORMANCE within the duration of the warranty coverage, a replacement part will be provided. Please see the CARE AND MAINTENANCE SECTION FOR MORE INFORMATION.

This limited warranty is nontransferable and becomes void if used for commercial or rental purposes. Should this product become defective within the stated warranty period, **do not return to store, but call 1-877-707-5463.**

Purchaser: By accepting delivery of this product, the purchaser hereby accepts the foregoing and expressly waives any other remedy and damages, direct, indirect, and consequential.

IMPORTANT

Do not use if temperature falls below 0C (32F). Periodically check all hardware and plastic parts for wear. Please retain these instructions for future reference. **Please keep sales receipt for proof of purchase.**

WARNINGS

- Please keep all assembly hardware, tools and packaging away from children.
 - Dispose of unused parts and their packages promptly.
 - **Do not** allow children to play in or around product.
 - Weight limit trash holder is 15lb.
 - Weight limit for the counter top is 20 lb (9 kg).
 - Remove trash from unit after every use to avoid attracting animals, and insects.
-

CARE AND MAINTENANCE

Do not use abrasive cleaners to clean any painted, porcelain or stainless steel parts. Exterior surfaces should be cleaned with warm soapy water, and dried thoroughly.

To protect against corrosion and discoloration please read the following.

Stainless Steel performs best when clean- cleanliness is essential for maximum resistance to corrosion. There are various practices for cleaning stainless Steel in use. This includes methods for removing free-iron contamination on stainless Steel surfaces. The salt air environment of coastal areas or a high humidity environment can be corrosive to Stainless Steel finishes. These conditions can cause rusting. Other contaminants include dirt, debris, residue from cleaners (many cleaners contain corrosive ingredients which require thorough post clean rinsing with clean water) or other material, hinders the passivation process and traps corrosive agents to the stainless steel, reducing corrosion protection. Routine cleaning is necessary to preserve and protect the appearance and integrity of the surface.

To clean stainless Steel surfaces, use a soft cloth and clean warm water to remove mild stains and loose dirt. Other cleaning agents include a stainless steel cleaner, a non-abrasive, chloride free, non-acidic cleaner, or simply a vinegar and water solution. Always wipe in the direction of the grain and ensure that the unit is dried thoroughly after cleaning. DO not use steel wool, as it will scratch the finish.

85-1066-6 (A01001)

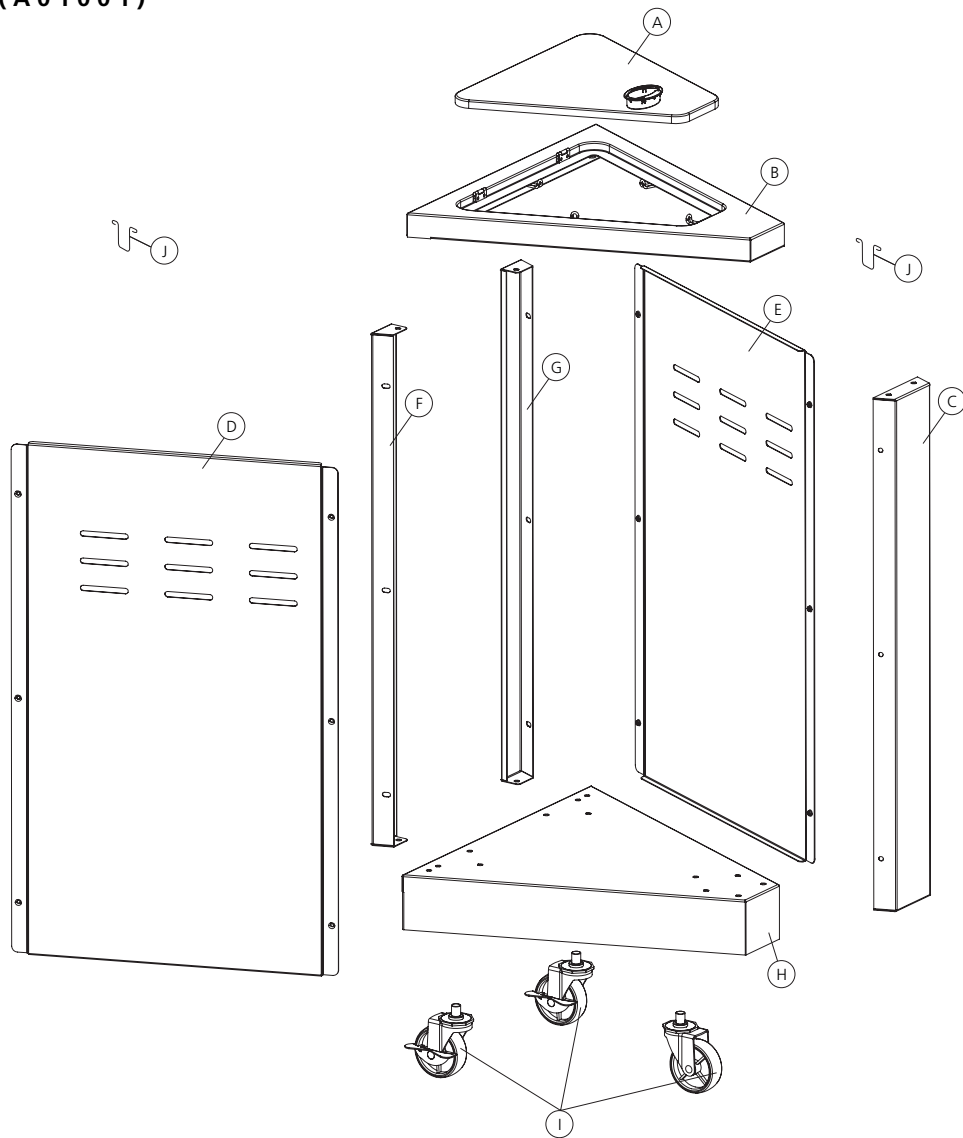

PARTS LIST

85-1066-6 (A01001)

Item No.	Quantity	Specification	Part No.
A	1	Top Lid	A010-0001-01
B	1	Top Panel Assembly	A010-0100-01
C	1	Front Shelf	A010-0003-01
D	1	Left Side Panel	A010-0005-01
E	1	Right Side Panel	A010-0006-01
F	1	Back Shelf, Left	A010-0002-01
G	1	Back Shelf, Right	A010-0007-01
H	1	Bottom Shelf	A010-0004-01
I	1	Caster Assembly	G401-0062-01
J	2	Joint Hook	A011-0039-01

ASSEMBLY INSTRUCTIONS

Tools Needed for Assembly

- Hammer
- Slotted screwdriver
- #3 Phillips® screwdriver
- Safety glasses

Before assembling the cart, read these instructions carefully. Assemble the cart on a flat, clean surface.

Notes: Do not fully tighten all the nuts during this initial stage.

You may have extra hardware after assembly is complete.

Hardware Pack List

No.	Description	Part Number	Quantity
1	1/4"-20UNCx13Screw	20120-13013-250	6
2	Ø7 Lock Washer	41400-07000-250	6
3	Ø7 Washer	40300-07000-250	6
4	1/4"-20UNC NUT	30220-13000-250	2
5	NO.10-24UNCx10 Screw	20124-10010-250	12
6	Ø5 Lock Washer	41400-05000-250	12
7	Ø5 Washer	40300-05000-250	12
8	Wrench	G401-0071-0182	1

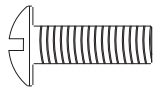

#1 – 1/4-20UNCx13Screw (6)



#4 – 1/4"-20UNC NUT (2)

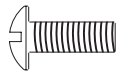

#5 – NO.10-24UNCx10 Screw (12)

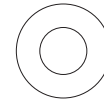

#7 – Ø5 Washer (12)

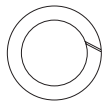

#3 – Ø7 Washer (6)

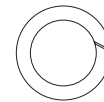

#2 – Ø7 Lock Washer (6)



#6 – Ø5 Lock Washer (12)

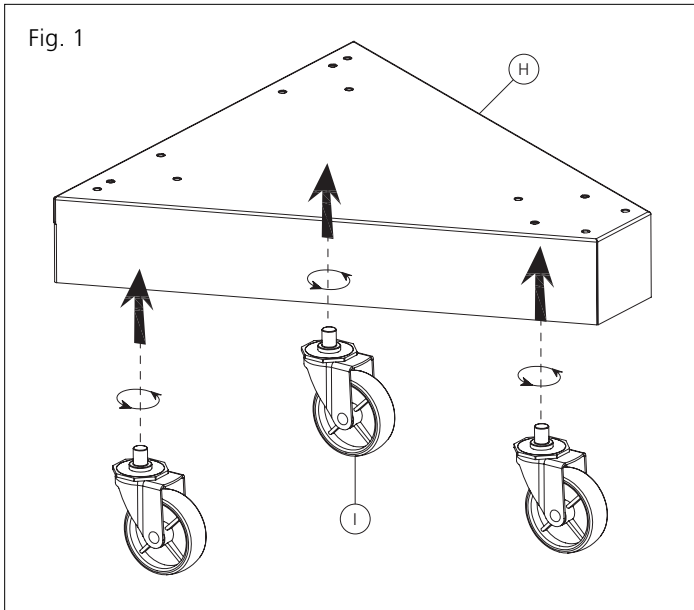

1

Assemble the three casters (I) to the bottom shelf (H) as shown.

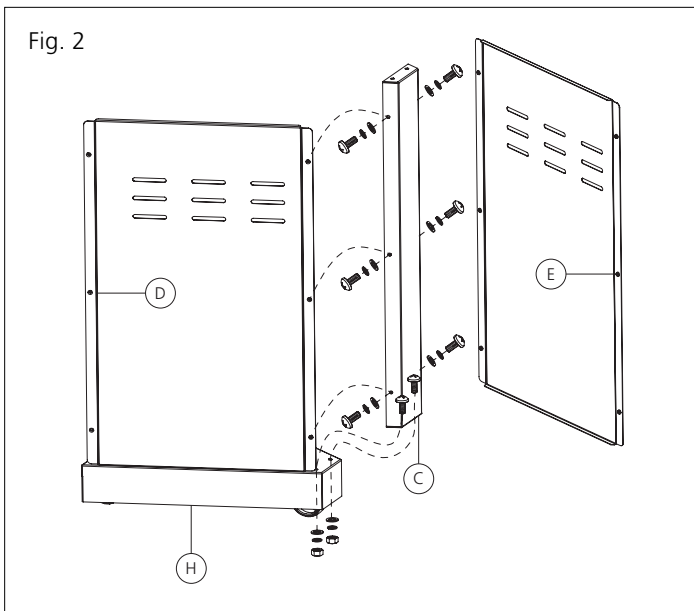

2

Assemble the left side panel (D) to the bottom shelf (H) using hardware #1, #2, #3, and #4 (x2) to Affix the front part of the left side panel (D) to the bottom shelf (H).

Affix the right side panel (E) to the bottom shelf (H) using hardware #1, #2, #3, and #4 (x2). Place the front shelf (C) between two side panels (D & E) as shown. Use hardware #5, #6, and #7 (x6) as shown to connect together with both side panels.

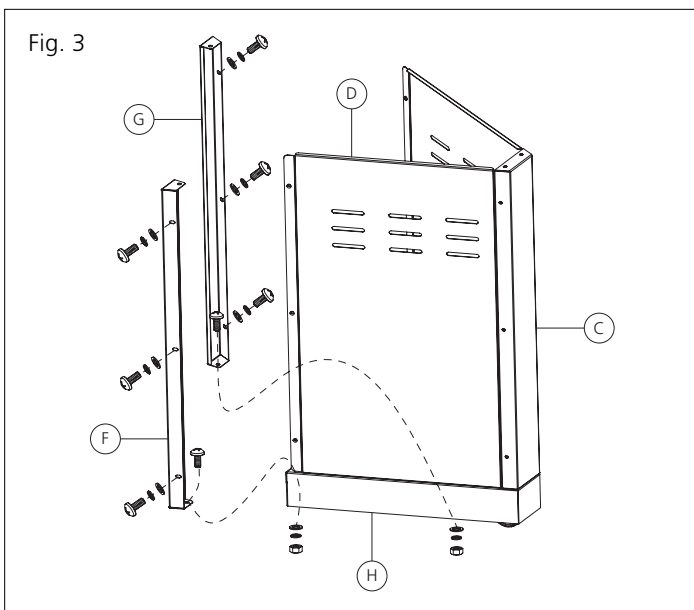

3

Affix the left and right back shelf (F & G) to the bottom panel using hardware #1, #2, #3, and #4 (x2) as shown.

Then Affix each back shelf to the side shelf using hardware #5, #6, and #7 (x6).

Fig. 4

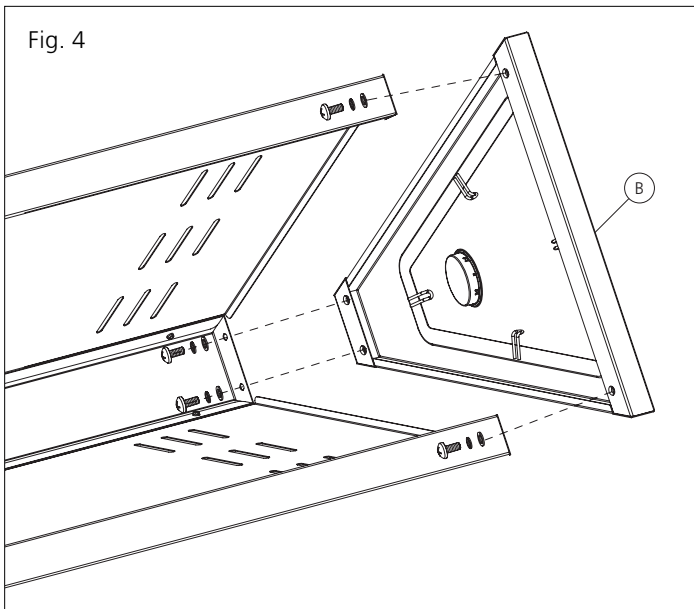

4

Assemble the top panel assembly (B) to the cart assembly using hardware #1, #2 and #3 (x4). Must fix the top panel (B) to the front and both side panels.

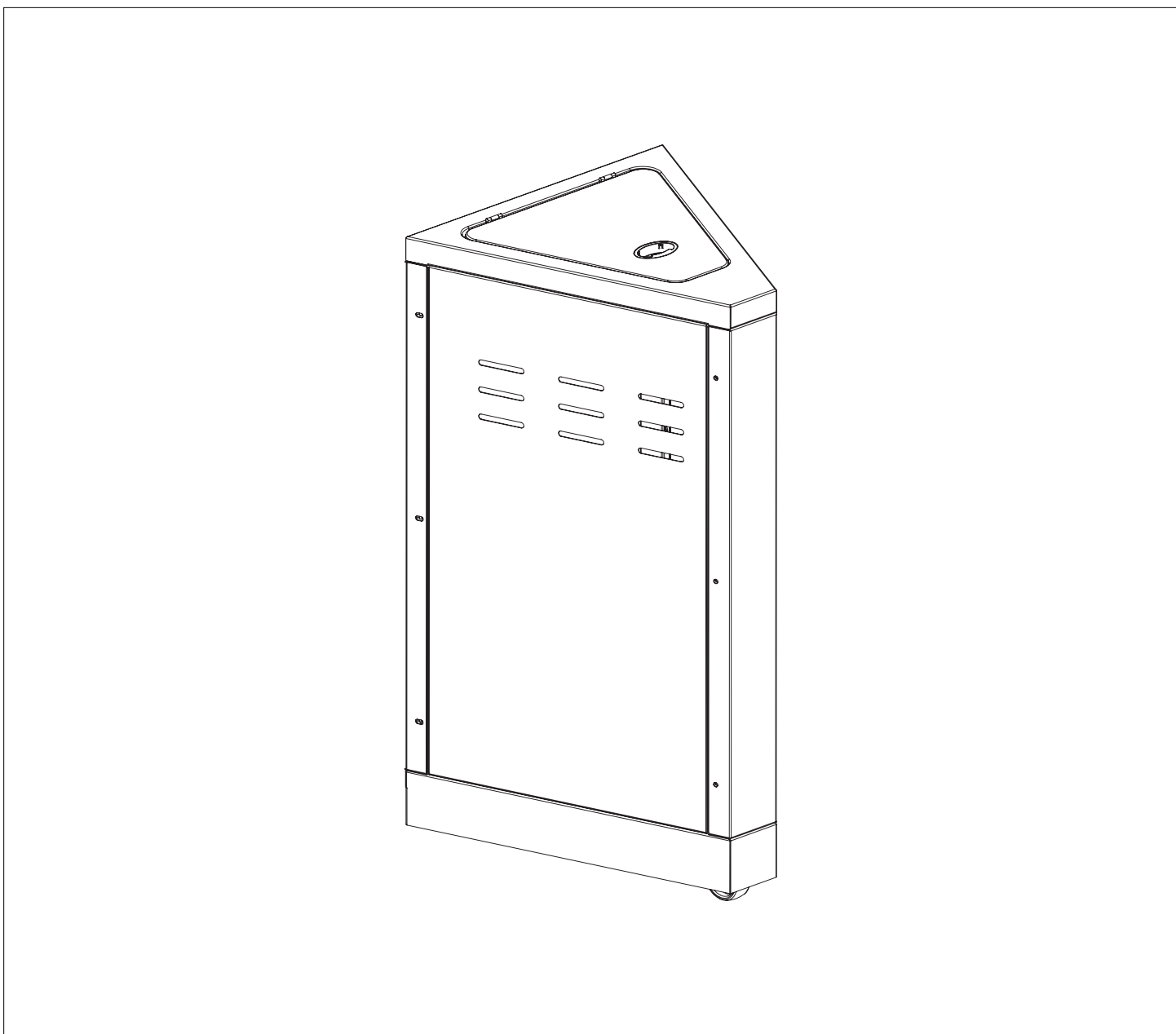

DISTRIBUTOR

Trileaf Distribution Trifeuil
Toronto, Canada
M4S 2B8



Free Manuals Download Website

<http://myh66.com>

<http://usermanuals.us>

<http://www.somanuals.com>

<http://www.4manuals.cc>

<http://www.manual-lib.com>

<http://www.404manual.com>

<http://www.luxmanual.com>

<http://aubethermostatmanual.com>

Golf course search by state

<http://golfingnear.com>

Email search by domain

<http://emailbydomain.com>

Auto manuals search

<http://auto.somanuals.com>

TV manuals search

<http://tv.somanuals.com>