

CHAMBERLAIN®

Whisper Drive®

The Chamberlain Group, Inc.
845 Larch Avenue
Elmhurst, Illinois 60126-1196
www.chamberlain.com



SECURITY+® GARAGE DOOR OPENER

Models WD952LD
WD952KD

For Residential Use Only

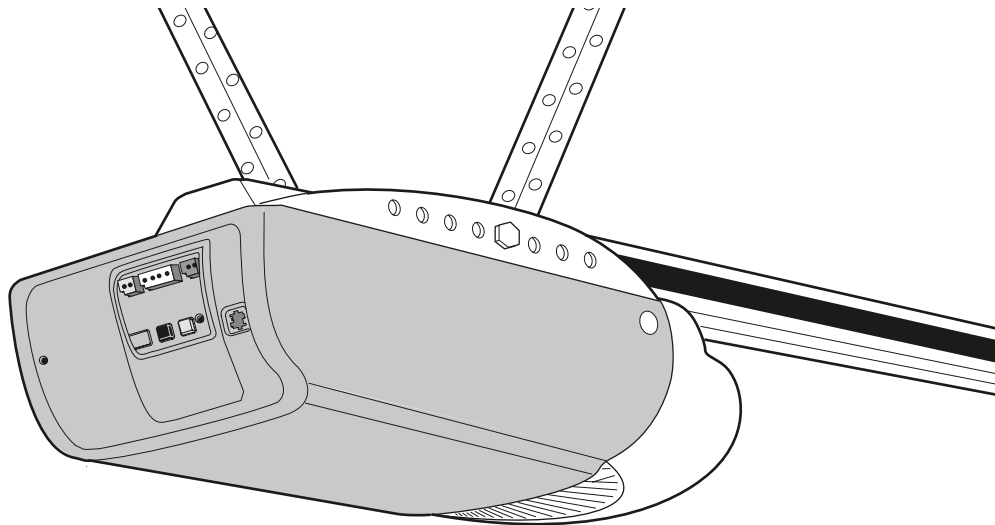

Owner's Manual

- Please read this manual and the enclosed safety materials carefully!
- Fasten the manual near the garage door after installation.
- The door WILL NOT CLOSE unless The Protector System® is connected and properly aligned.
- Periodic checks of the opener are required to ensure safe operation.
- The model number label is located on the front panel of your opener.

TABLE OF CONTENTS

| | | | |
|--|--------------|--|--------------|
| Introduction | 2-7 | Adjustment | 27-29 |
| Safety symbol and signal word review..... | 2 | Program the travel limits | 27 |
| Preparing your garage door | 3 | Setting the force | 28 |
| Tools needed..... | 3 | Test the safety reversal system..... | 29 |
| Planning | 4-5 | Test The Protector System® | 29 |
| Carton inventory..... | 6 | Operation | 30-36 |
| Hardware inventory | 7 | Operation safety instructions..... | 30 |
| Assembly | 8-11 | Using your garage door opener | 30 |
| Assemble the rail and install the trolley | 8 | Using the wall-mounted door control | 31 |
| Fasten the rail to the motor unit..... | 9 | To open the door manually..... | 31 |
| Install the idler pulley..... | 9 | Battery backup unit | 32-33 |
| Install the belt and attach the belt cap retainer..... | 10 | Care of your garage door opener..... | 34 |
| Set the tension | 11 | Having a problem? | 35 |
| Installation | 11-26 | Diagnostic chart..... | 36 |
| Installation safety instructions..... | 11 | Programming | 37-38 |
| Determine the header bracket location | 12 | To add or reprogram a hand-held remote control | 37 |
| Install the header bracket..... | 13 | To erase all codes from motor unit memory..... | 37 |
| Attach the rail to the header bracket..... | 14 | 3-Button remotes..... | 37 |
| Position the opener | 15 | To add, reprogram or change | |
| Hang the opener | 16 | a Keyless Entry PIN | 38 |
| Install the door control..... | 17 | Repair Parts | 39-40 |
| Install the lights | 18 | Rail assembly parts..... | 39 |
| Attach the emergency release rope and handle | 18 | Installation parts | 39 |
| Electrical requirements..... | 19 | Motor unit assembly parts | 40 |
| Install The Protector System® | 20-22 | Accessories | 41 |
| Fasten the door bracket..... | 23-24 | Notes | 42-43 |
| Connect the door arm to the trolley | 25-26 | Repair Parts and Service | 44 |
| | | Warranty | 44 |

INTRODUCTION

Safety Symbol and Signal Word Review

This garage door opener has been designed and tested to offer safe service provided it is installed, operated, maintained and tested in strict accordance with the instructions and warnings contained in this manual.

**WARNING**

Mechanical

**WARNING**

Electrical

CAUTION

When you see these Safety Symbols and Signal Words on the following pages, they will alert you to the possibility of **serious injury or death** if you do not comply with the warnings that accompany them. The hazard may come from something mechanical or from electric shock. Read the warnings carefully.

When you see this Signal Word on the following pages, it will alert you to the possibility of damage to your garage door and/or the garage door opener if you do not comply with the cautionary statements that accompany it. Read them carefully.

Preparing your garage door

Before you begin:

- Disable locks.
- Remove any ropes connected to garage door.
- **Complete the following test** to make sure your garage door is balanced and is not sticking or binding:
 1. Lift the door about halfway as shown. Release the door. If balanced, it should stay in place, supported entirely by its springs.
 2. Raise and lower the door to see if there is any binding or sticking.

If your door binds, sticks, or is out of balance, call a trained door systems technician.

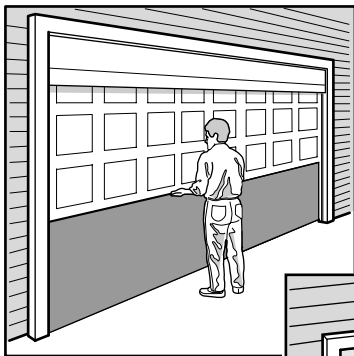

Sectional Door

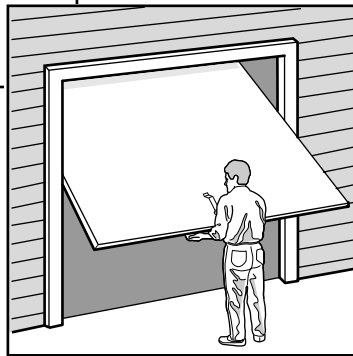

One-Piece Door

⚠ WARNING

To prevent possible **SERIOUS INJURY** or **DEATH**:

- **ALWAYS** call a trained door systems technician if garage door binds, sticks, or is out of balance. An unbalanced garage door may not reverse when required.
- **NEVER** try to loosen, move or adjust garage door, door springs, cables, pulleys, brackets or their hardware, all of which are under **EXTREME** tension.
- Disable **ALL** locks and remove **ALL** ropes connected to garage door **BEFORE** installing and operating garage door opener to avoid entanglement.

CAUTION

To prevent damage to garage door and opener:

- **ALWAYS** disable locks **BEFORE** installing and operating the opener.
- **ONLY** operate garage door opener at 120V, 60 Hz to avoid malfunction and damage.

Tools needed

During assembly, installation and adjustment of the opener, instructions will call for hand tools as illustrated below.

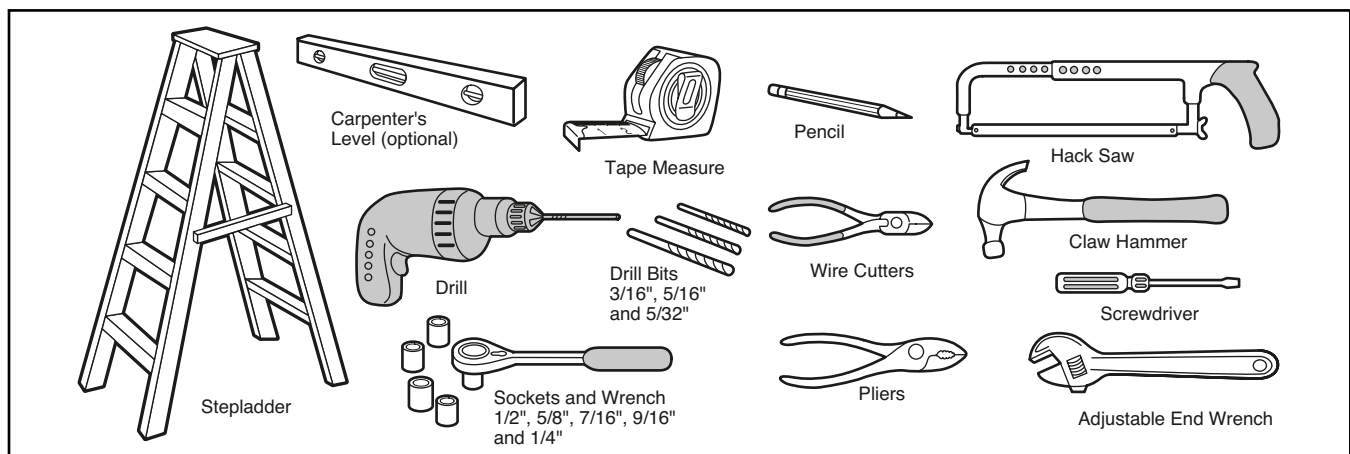

Planning

Identify the type and height of your garage door. Survey your garage area to see if any of the conditions below apply to your installation. Additional materials may be required. You may find it helpful to refer back to this page and the accompanying illustrations as you proceed with the installation of your opener.

Depending on your requirements, there are several installation steps which may call for materials or hardware not included in the carton.

- Installation Step 1 – Look at the wall or ceiling above the garage door. The header bracket must be securely fastened to structural supports.
- Installation Step 5 – Do you have a finished ceiling in your garage? If so, a support bracket and additional fastening hardware may be required.
- Installation Step 10 – Depending upon garage construction, extension brackets or wood blocks may be needed to install sensors.
- Installation Step 10 – Alternate floor mounting of the safety reversing sensor will require hardware not provided.

- Do you have an access door in addition to the garage door? If not, Model 7702CB Emergency Key Release is required. See Accessories page.
- Look at the garage door where it meets the floor. Any gap between the floor and the bottom of the door must not exceed 1/4" (6 mm). Otherwise, the safety reversal system may not work properly. See Adjustment Step 3. Floor or door should be repaired.

SECTIONAL DOOR INSTALLATIONS

- Do you have a steel, aluminum, fiberglass or glass panel door? If so, horizontal and vertical reinforcement is required (Installation Step 11).
- The opener should be installed above the center of the door. If there is a torsion spring or center bearing plate in the way of the header bracket, it may be installed within 4 feet (1.21 m) to the left or right of the door center. See Installation Steps 1 and 11.
- If your door is more than 7 feet (2.12 m) high, see rail extension kits listed on Accessories page.

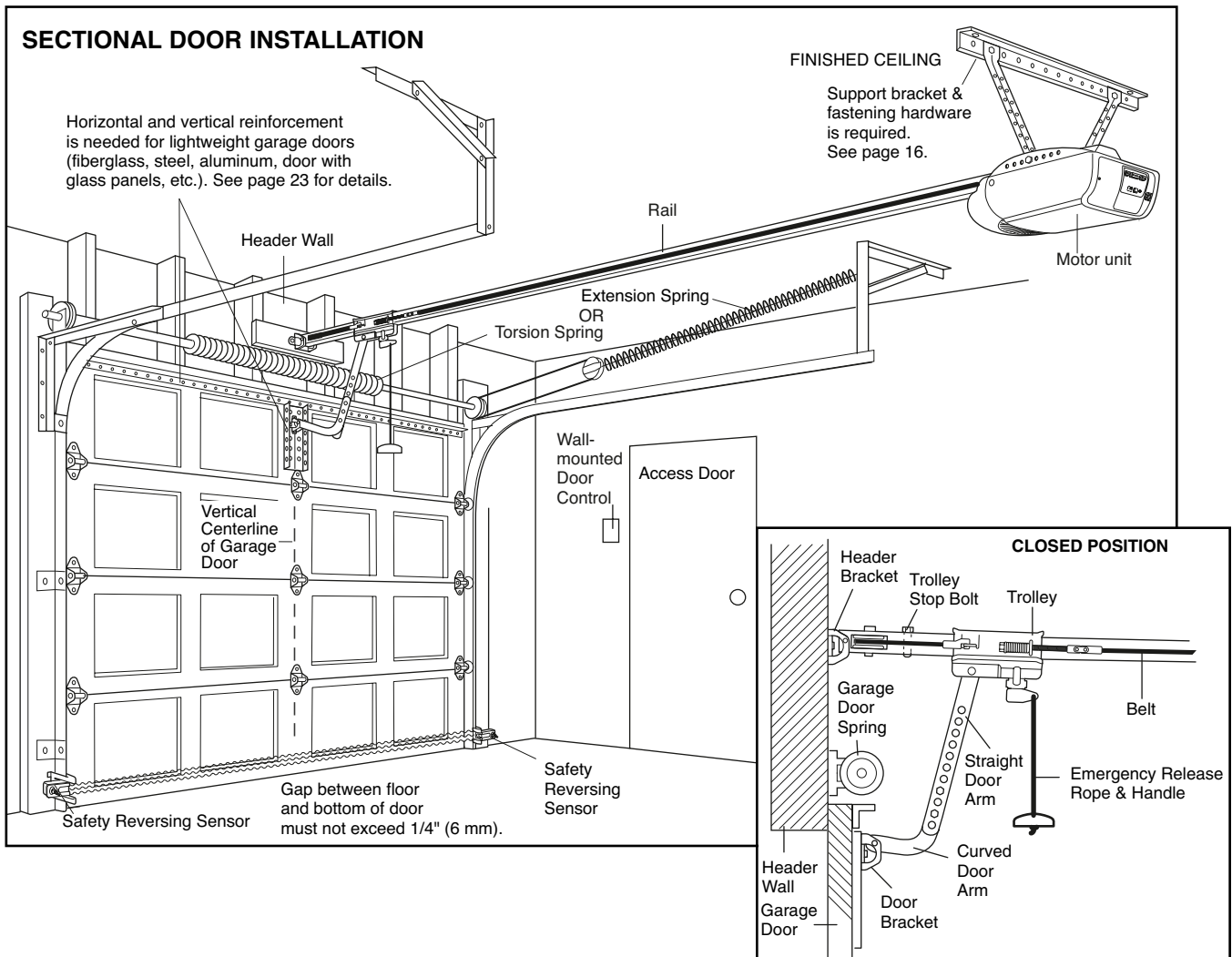

Planning (Continued)

ONE-PIECE DOOR INSTALLATIONS

- Generally, a one-piece door does not require reinforcement. If your door is lightweight, refer to the information relating to sectional doors in Installation Step 11.
- Depending on your door's construction, you may need additional mounting hardware for the door bracket (Step 11).

⚠ WARNING

Without a properly working safety reversal system, persons (particularly small children) could be SERIOUSLY INJURED or KILLED by a closing garage door.

- The gap between the bottom of the garage door and the floor **MUST NOT** exceed 1/4" (6 mm). Otherwise, the safety reversal system may not work properly.
- The floor or the garage door **MUST** be repaired to eliminate the gap.

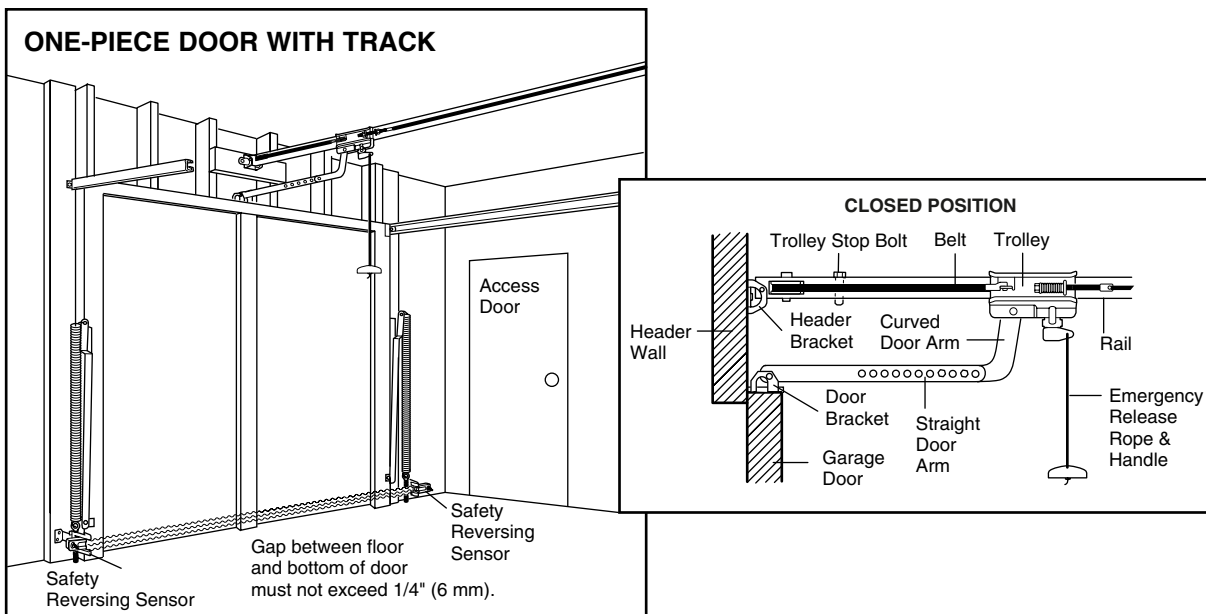
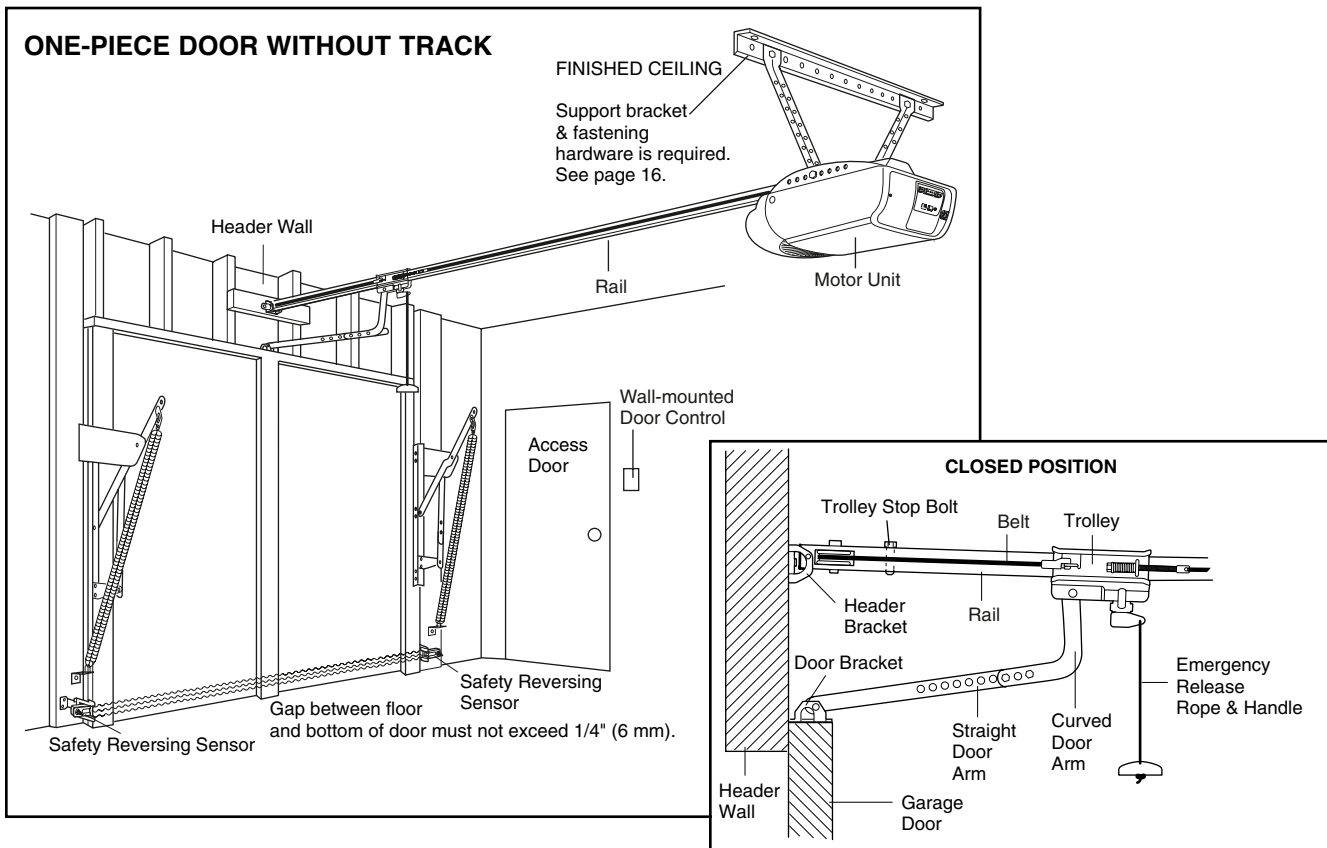

Carton Inventory

Your garage door opener is packaged in one carton which contains the motor unit and all parts illustrated below. Accessories will depend on the model purchased. If anything is missing, carefully check the

packing material. Parts may be stuck in the foam. Hardware for assembly and installation is shown on the next page. Save the carton and packing material until installation and adjustment is complete.

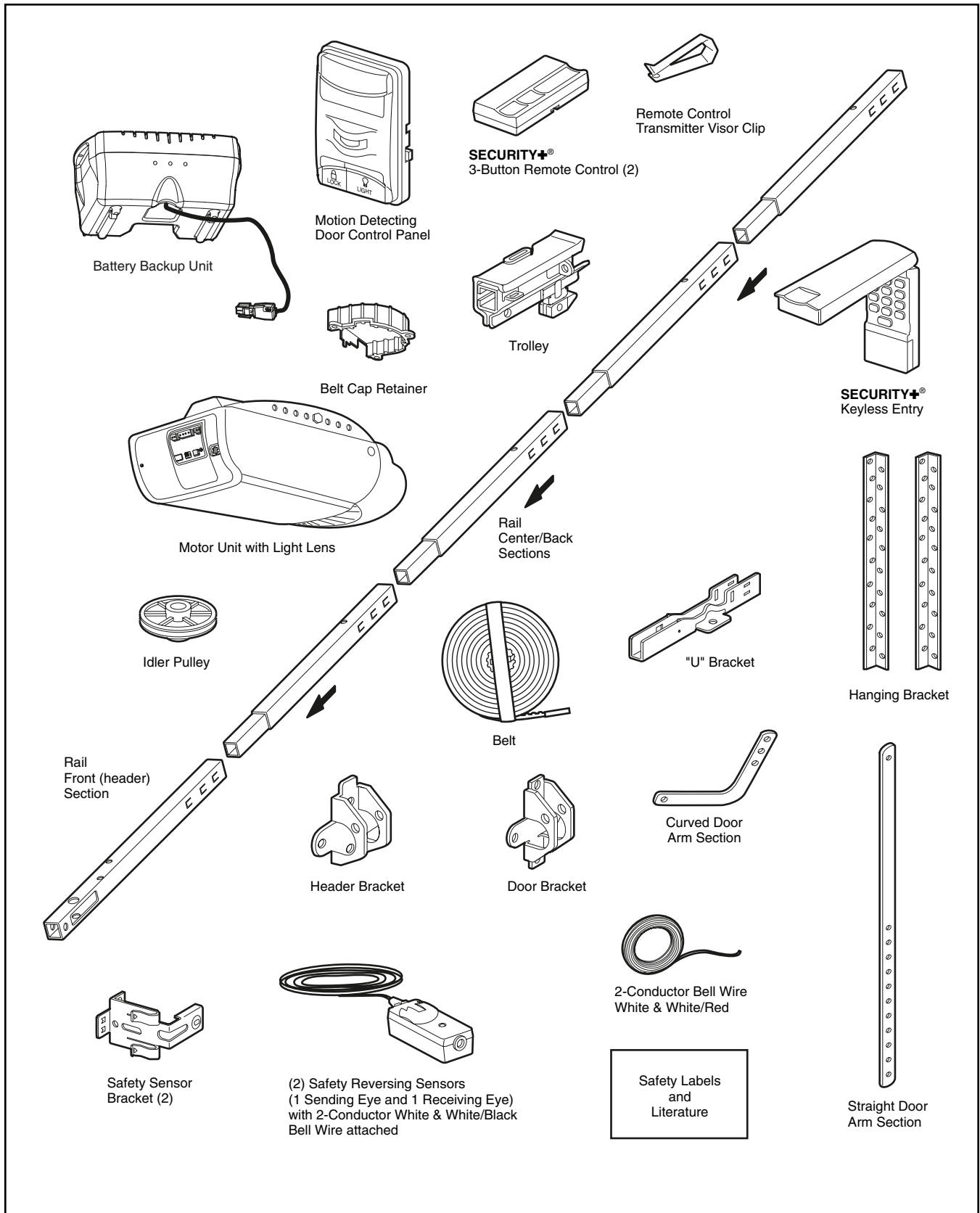

Hardware Inventory

Separate all hardware and group as shown below for the assembly and installation procedures.

ASSEMBLY HARDWARE

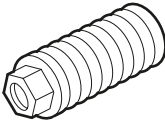

Spring/Trolley Nut (1)



Lock Nut
1/4"-20 (2)



Lock Washer
3/8" (1)



Nut
3/8" (1)

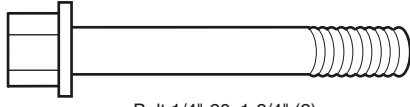

Bolt 1/4"-20x1-3/4" (2)

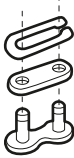

Master Link (2)

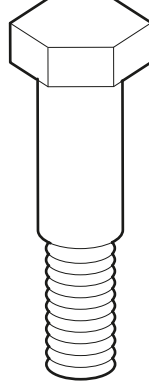

Idler Bolt (1)

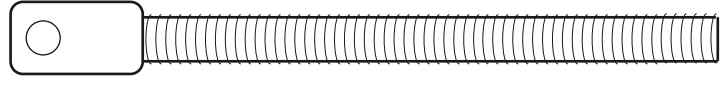

Trolley Threaded Shaft (1)

INSTALLATION HARDWARE

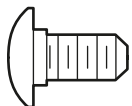

Carriage Bolt
1/4"-20x1/2" (2)

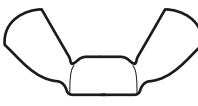

Wing Nut
1/4"-20 (2)



Ring
Fastener (3)



Nut 5/16"-18 (8)



Handle

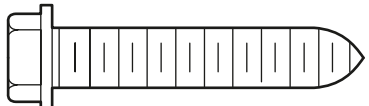

Lag Screw
5/16"-9x1-5/8" (2)

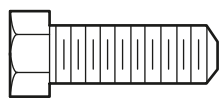

Hex Bolt
5/16"-18x7/8" (4)



Lock Washer 5/16" (7)



Insulated
Staples (30)

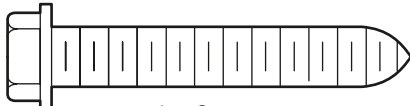

Lag Screw
5/16"-18x1-7/8" (2)



Screw
6ABx1-1/4" (2)



Screw 6-32x1" (2)

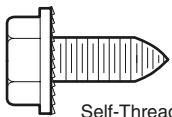

Self-Threading Screw
1/4"-14x5/8" (2)

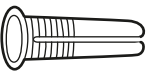

Drywall Anchors (2)

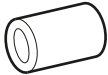

Spacer (2)



Rope



Clevis Pin
5/16"x1-1/2" (1)



Clevis Pin
5/16"x1" (1)

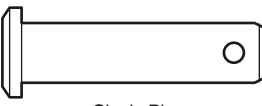

Clevis Pin
5/16"x1-1/4" (1)

ASSEMBLY STEP 1

Assemble the Rail & Install the Trolley

To avoid installation difficulties, do not run the garage door opener until instructed to do so.

The front rail has a cut out "window" at the door end (see illustration). **The hole above this window is larger on the top of the rail than on the bottom.** A smaller hole 3-1/2" (8.9 cm) away is close to the rail edge. Rotate the back rail so it has a similar hole close to the **opposite** edge, about 4-3/4" (12 cm) from the far end.

1. Remove the straight door arm and hanging bracket packaged inside the front rail and set aside for Installation Step 5 and 12. **NOTE:** To prevent **INJURY** while unpacking the rail carefully remove the straight door arm stored within the rail section.
2. Align the rail sections on a flat surface as shown and slide the tapered ends into the larger ones. Tabs along the side will lock into place.

| CAUTION |
|--|
| To prevent INJURY from pinching, keep hands and fingers away from the joints while assembling the rail. |

3. Place the motor unit on packing material to protect the cover, and rest the back end of the rail on top. For convenience, put a support under the front end of the rail.
4. As a temporary stop, insert a screwdriver into the hole 10" (25 cm) from the front end of the rail, as shown.
5. Check to be sure there are 4 plastic wear pads inside the inner trolley. If they became loose during shipping, check all packing material. Snap them back into position as shown.
6. Slide the trolley assembly along the rail from the back end to the screwdriver.

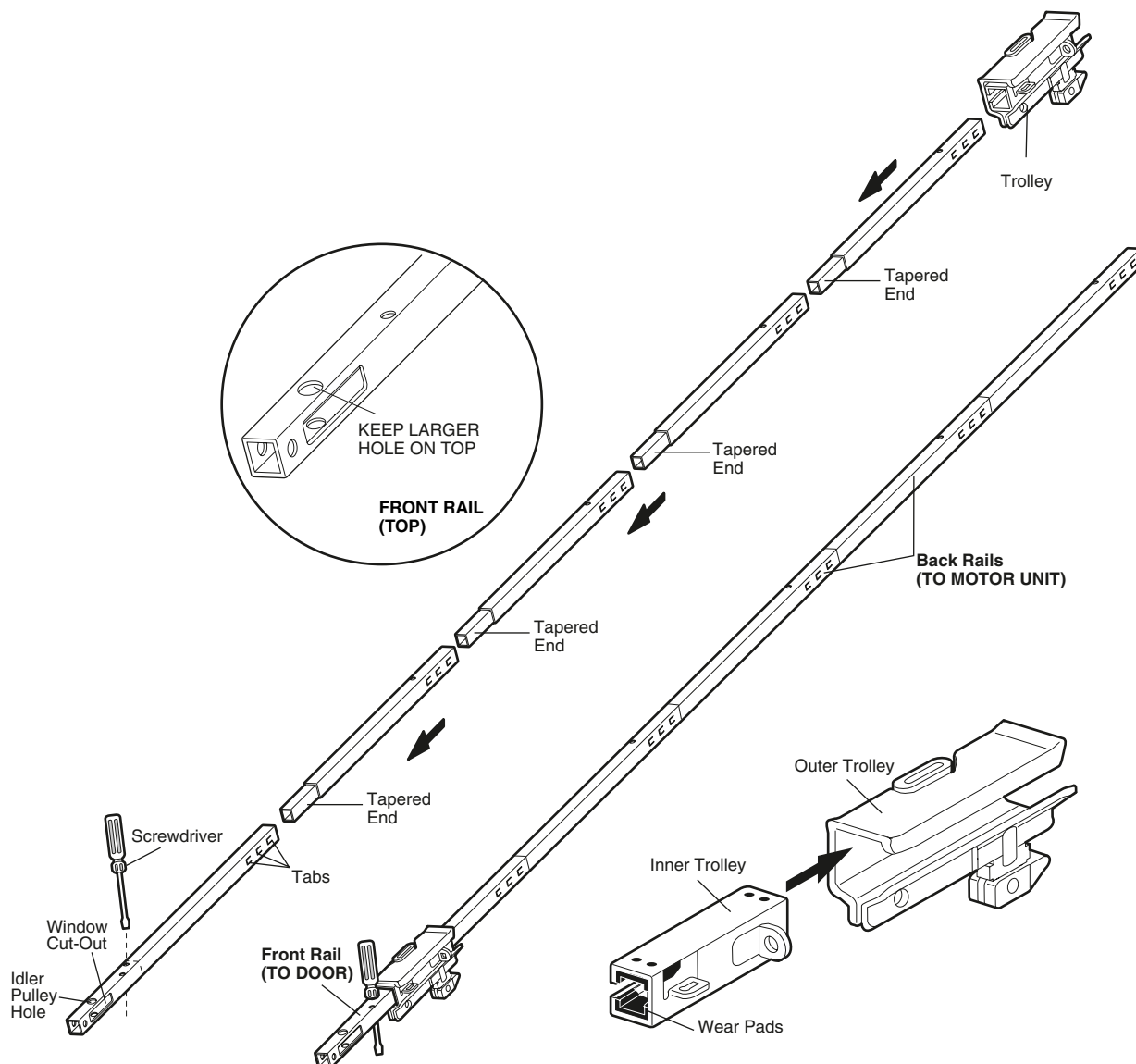

ASSEMBLY STEP 2

Fasten the Rail to the Motor Unit

- Insert a 1/4"-20x1-3/4" bolt into the cover protection bolt hole on the back end of the rail as shown. Tighten securely with a 1/4"-20 lock nut. *Do NOT overtighten.*
- Remove the two bolts from the top of the motor unit.
- Place the "U" bracket, flat side down, on the motor unit and align the bracket holes with the bolt holes. Fasten with the previously removed bolts.
- Align the rail assembly with the top of the motor unit. Slide the rail end onto the "U" bracket, *all the way to the stops that protrude on the top and sides of the bracket.*

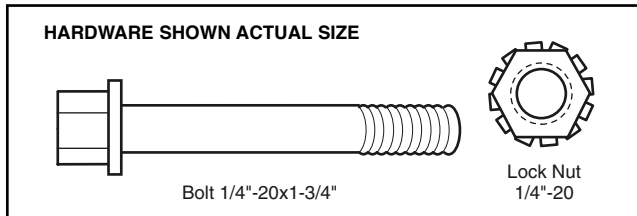

CAUTION

To avoid **SERIOUS** damage to garage door opener, use **ONLY** those bolts/fasteners mounted in the top of the opener.

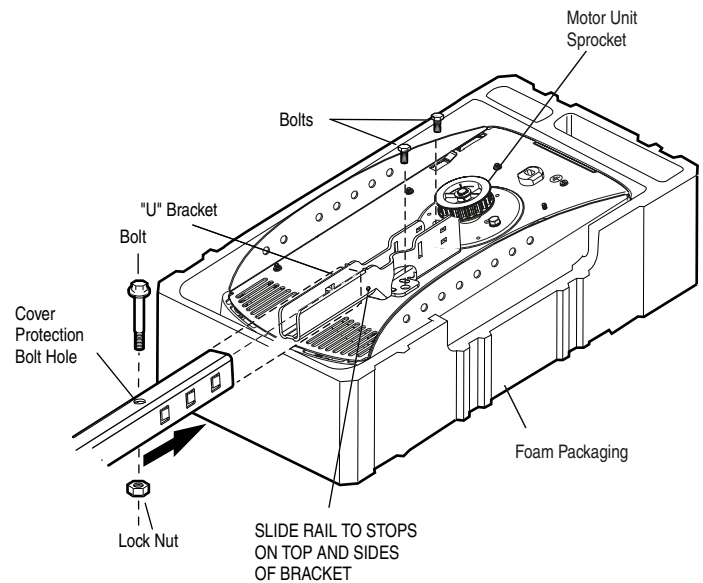

ASSEMBLY STEP 3

Install the Idler Pulley

- Lay the belt beside the rail, as shown. Grasp the end with the hooked trolley connector and pass approximately 12" (30 cm) of belt through the window. Keep the ribbed side toward the rail, and allow it to hang until Assembly Step 5.
- Remove the tape from the idler pulley. The inside center should be pre-greased. If dry, regrease to ensure proper operation.
- Place the idler pulley into the window as shown.
- Insert the idler bolt from the top through the rail and pulley. Tighten with a 3/8" lock washer and nut underneath the rail until the lock washer is compressed.
- Rotate the pulley to be sure it spins freely.
- Insert a 1/4"-20x1-3/4" bolt into the trolley stop hole in the front of the rail as shown. Tighten securely with a 1/4"-20 lock nut.

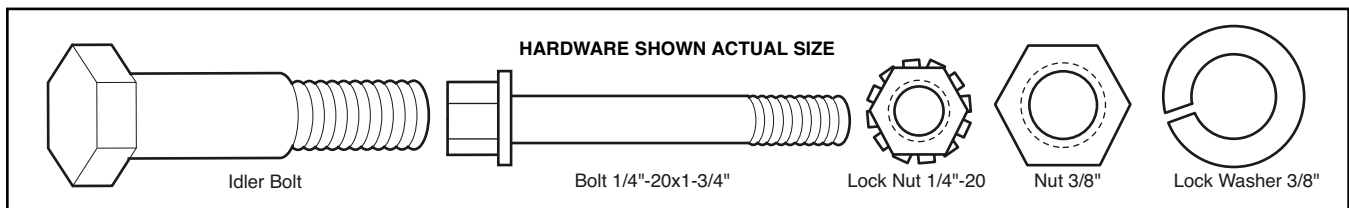
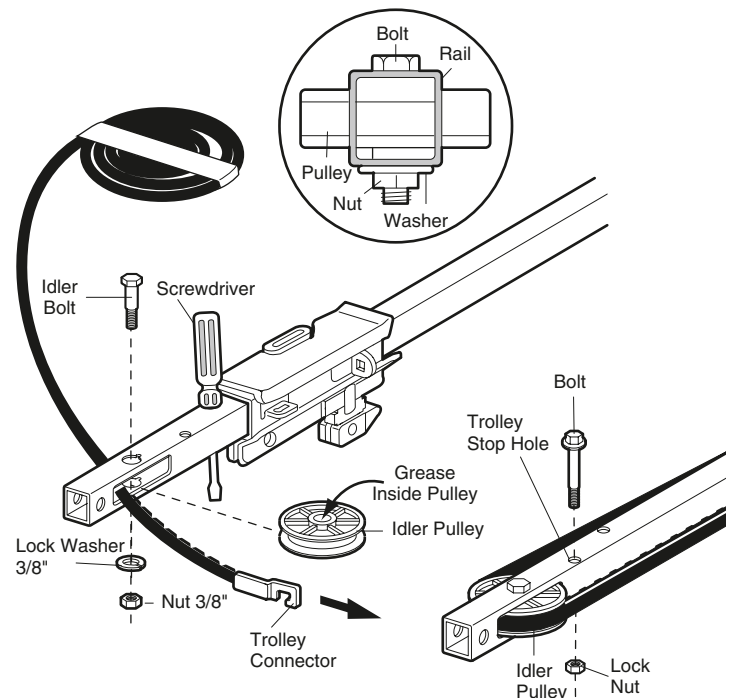

ASSEMBLY STEP 4

Install the Belt and Attach the Belt Cap Retainer

1. Pull the belt around the idler pulley and toward the trolley. *The ribbed side must contact the pulley.*
2. Hook the trolley connector into the retaining slot on the trolley as shown.
3. With the trolley against the screwdriver, dispense the remainder of the belt along the rail length toward the motor unit and around the sprocket. The sprocket teeth must engage the belt.
4. Check to make sure the belt is not twisted, then connect it to the flat end of the trolley threaded shaft with the master link, as illustrated:
 - Push pins of master link bar through holes in end of belt and trolley threaded shaft.
 - Push master link cap over pins and past pin notches.
 - Slide clip-on spring over cap and onto pin notches until both pins are securely locked in place.
5. Insert the trolley threaded shaft through the hole in the trolley. *Be sure the belt is not twisted, and the ribbed side faces the rail.*
6. Hold the belt at the trolley shaft as you thread the spring nut by hand onto the shaft until finger tight against the trolley. *Do not use any tools.*
7. Remove the screwdriver.
8. Position the belt cap retainer over the motor unit sprocket as shown and fasten to the mounting plate with 8x3/8" hex screws provided.

⚠ WARNING

To avoid possible SERIOUS INJURY to fingers from moving garage door opener:

- ALWAYS keep hand clear of sprocket while operating opener.
- Securely attach sprocket cover BEFORE operating.

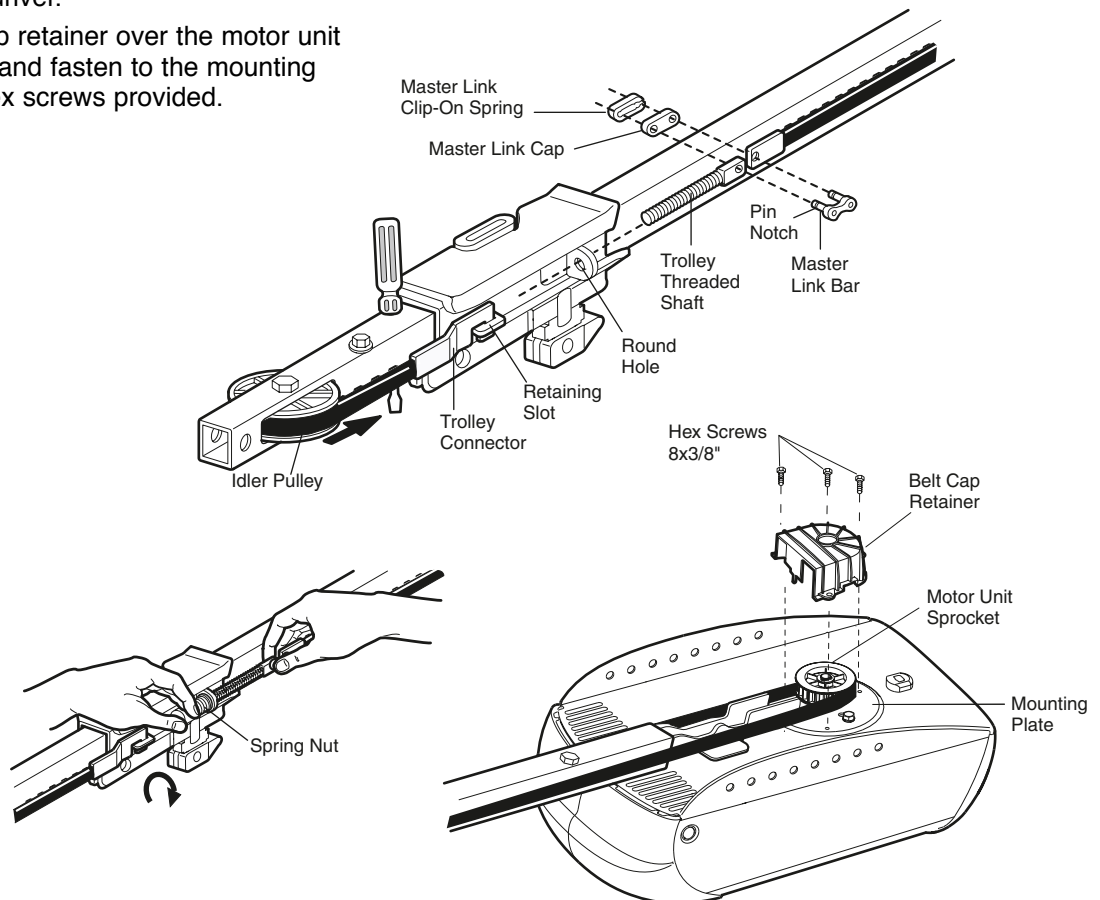
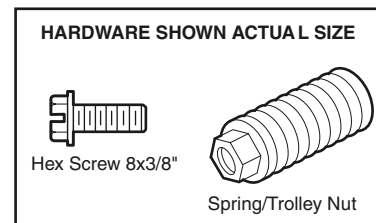

ASSEMBLY STEP 5

Set the Tension

- Insert a screwdriver tip into one of the nut ring slots and brace it firmly against the trolley.
- Place a 7/16" open end wrench on the square end. Rotate the nut about 1/4 turn until the spring releases and snaps the nut ring against the trolley.

This sets the spring to optimum belt tension.

You have now finished assembling your garage door opener. Please read the following warnings before proceeding to the installation section.

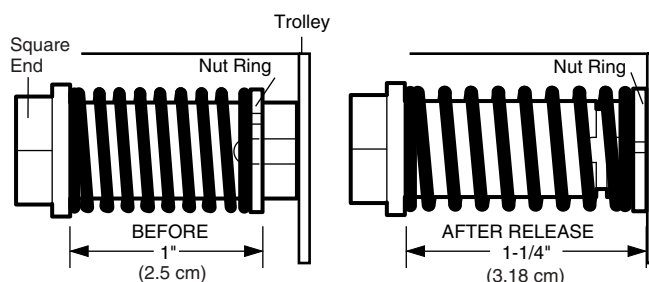
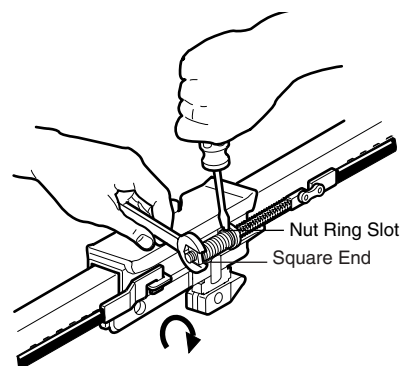

INSTALLATION

IMPORTANT INSTALLATION INSTRUCTIONS

WARNING

To reduce the risk of SEVERE INJURY or DEATH:

1. READ AND FOLLOW ALL INSTALLATION WARNINGS AND INSTRUCTIONS.
2. Install garage door opener only on properly balanced and lubricated garage door. An improperly balanced door may not reverse when required and could result in SEVERE INJURY or DEATH.
3. All repairs to cables, spring assemblies and other hardware MUST be made by a trained door systems technician BEFORE installing opener.
4. Disable all locks and remove all ropes connected to garage door BEFORE installing opener to avoid entanglement.
5. Install garage door opener 7 feet (2.12 m) or more above floor.
6. Mount emergency release handle 6 feet (1.82 m) above floor.
7. NEVER connect garage door opener to power source until instructed to do so.
8. NEVER wear watches, rings or loose clothing while installing or servicing opener. They could be caught in garage door or opener mechanisms.
9. Install wall-mounted garage door control:
 - within sight of the garage door.
 - out of reach of children at minimum height of 5 feet (1.52 m).
 - away from all moving parts of the door.
10. Place entrapment warning label on wall next to garage door control.
11. Place manual release/safety reverse test label in plain view on inside of garage door.
12. Upon completion of installation, test safety reversal system. Door MUST reverse on contact with a 1-1/2" (3.8 cm) high object (or a 2x4 laid flat) on the floor.

INSTALLATION STEP 1

Determine the Header Bracket Location

⚠ WARNING

To prevent possible SERIOUS INJURY or DEATH:

- Header bracket **MUST** be RIGIDLY fastened to structural support on header wall or ceiling, otherwise garage door might not reverse when required. **DO NOT** install header bracket over drywall.
- Concrete anchors **MUST** be used if mounting header bracket or 2x4 into masonry.
- NEVER try to loosen, move or adjust garage door, springs, cables, pulleys, brackets, or their hardware, all of which are under EXTREME tension.
- ALWAYS call a trained door systems technician if garage door binds, sticks, or is out of balance. An unbalanced garage door might not reverse when required.

Installation procedures vary according to garage door types. Follow the instructions which apply to your door.

1. Close the door and mark the inside vertical centerline of the garage door.
2. Extend the line onto the header wall above the door.

You can fasten the header bracket within 4 feet (1.21 m) of the left or right of the door center only if a torsion spring or center bearing plate is in the way; or you can attach it to the ceiling (see page 13) when clearance is minimal. (It may be mounted on the wall upside down if necessary, to gain approximately 1/2" [1.3 cm].)

If you need to install the header bracket on a 2x4 (on wall or ceiling), use lag screws (not provided) to securely fasten the 2x4 to structural supports as shown here and on page 13.

3. Open your door to the highest point of travel as shown. Draw an intersecting horizontal line on the header wall above the high point:
 - 2" (5 cm) above the high point for sectional door and one-piece door with track.
 - 8" (20 cm) above the high point for one-piece door without track.

This height will provide travel clearance for the top edge of the door.

NOTE: If the total number of inches exceeds the height available in your garage, use the maximum height possible, or refer to page 13 for ceiling installation.

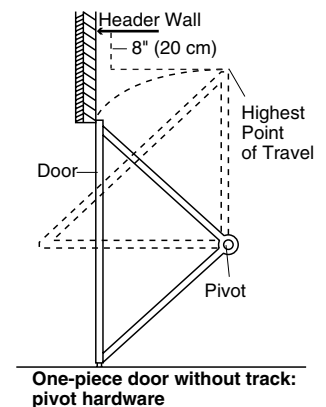
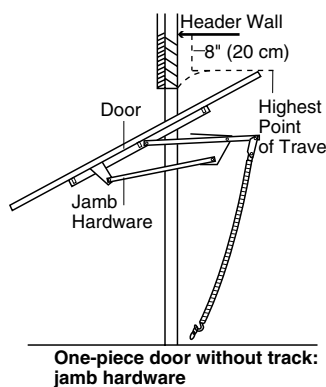
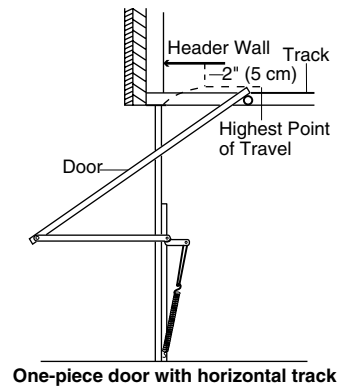
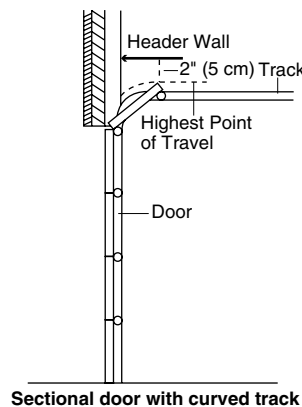
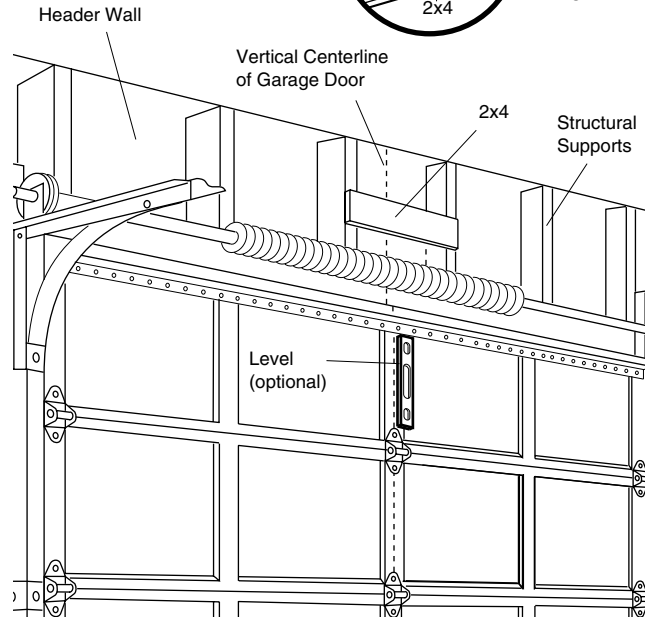
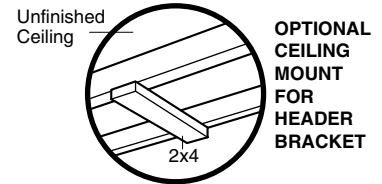

INSTALLATION STEP 2

Install the Header Bracket

You can attach the header bracket either to the wall above the garage door, or to the ceiling. Follow the instructions which will work best for your particular requirements. **Do not install the header bracket over drywall. If installing into masonry, use concrete anchors (not provided).**

WALL HEADER BRACKET INSTALLATION

- Center the bracket on the vertical centerline with the bottom edge of the bracket on the horizontal line as shown (with the arrow pointing toward the ceiling).
- Mark the vertical set of bracket holes (do not use the holes designated for ceiling mount). Drill $3/16"$ pilot holes and fasten the bracket securely to a structural support with the hardware provided.

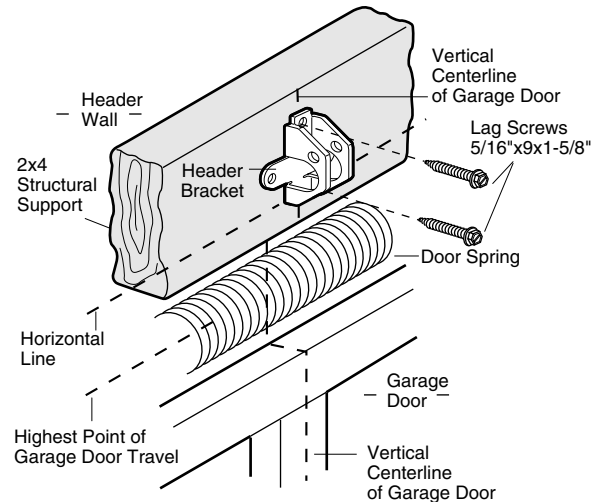
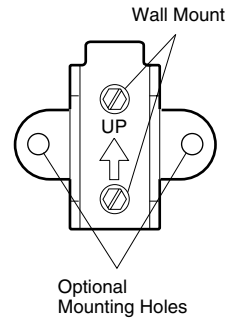
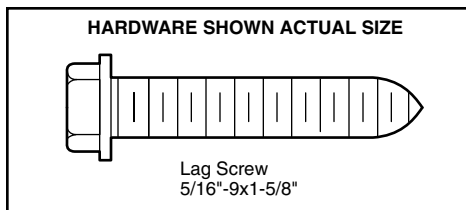

CEILING HEADER BRACKET INSTALLATION

- Extend the vertical centerline onto the ceiling as shown.
- Center the bracket on the vertical mark, no more than 6" (15 cm) from the wall. Make sure the arrow is pointing away from the wall. The bracket can be mounted flush against the ceiling when clearance is minimal.
- Mark the side holes. Drill $3/16"$ pilot holes and fasten bracket securely to a structural support with the hardware provided.

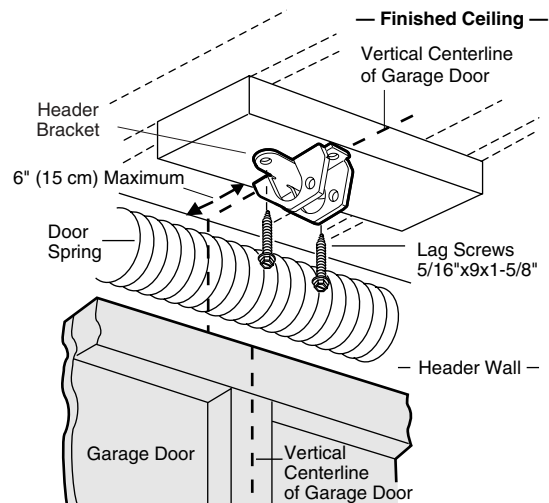
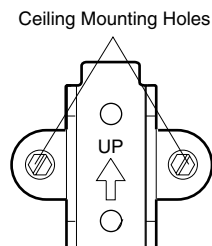

INSTALLATION STEP 3

Attach the Rail to the Header Bracket

NOTE: (Optional) With some existing installations, you may re-use the old header bracket with the two plastic spacers included in the hardware bag. Place the spacers inside the bracket on each side of the rail, as illustrated.

- Position the opener on the garage floor below the header bracket. Use packing material as a protective base. **NOTE:** If the door spring is in the way you'll need help. Have someone hold the opener securely on a temporary support to allow the rail to clear the spring.
- Position the rail bracket against the header bracket.
- Align the bracket holes and join with a clevis pin 5/16"x1-1/2" as shown.
- Insert a ring fastener to secure.

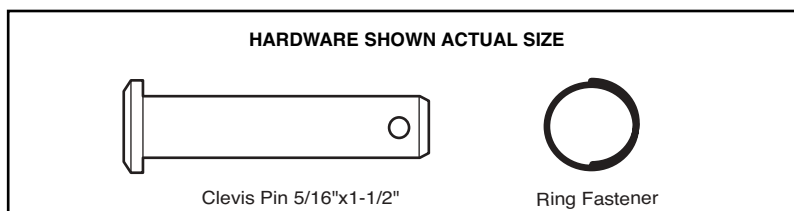
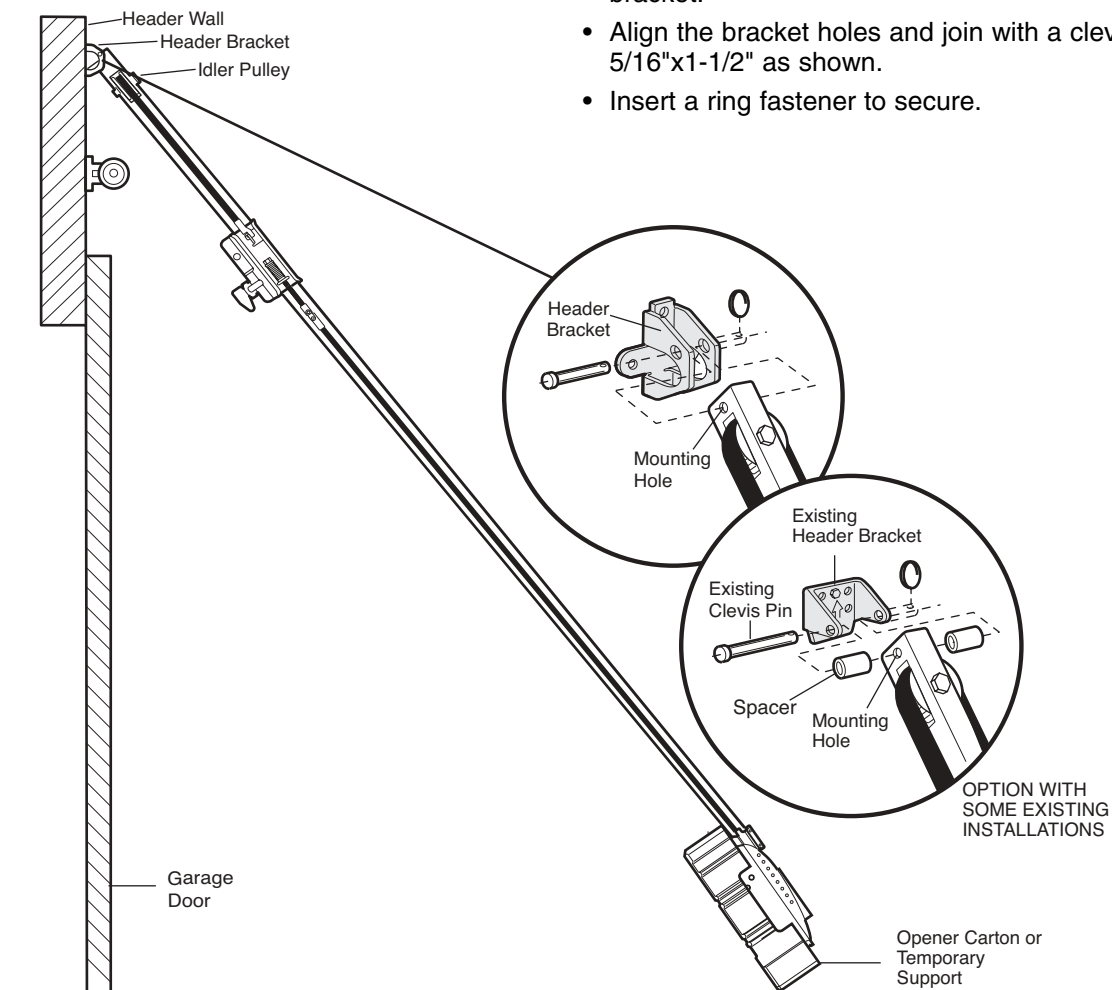

INSTALLATION STEP 4

Position the Opener

Follow instructions which apply to your door type as illustrated.

SECTIONAL DOOR OR ONE-PIECE DOOR WITH TRACK

A 2x4 laid flat is convenient for setting an ideal door-to-rail distance.

- Remove foam packaging.
- Raise the opener onto a stepladder. You will need help at this point if the ladder is not tall enough.
- Open the door all the way and place a 2x4 laid flat on the top section beneath the rail.
- If the top section or panel hits the trolley when you raise the door, pull down on the trolley release arm to disconnect inner and outer sections. Slide the outer trolley toward the motor unit. The trolley can remain disconnected until Installation Step 12 is completed.

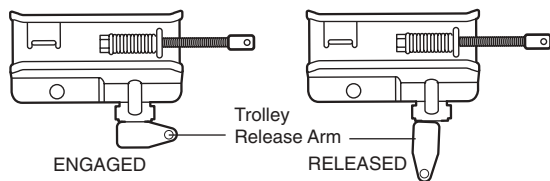

ONE-PIECE DOOR WITHOUT TRACK

A 2x4 on its side is convenient for setting an ideal door-to-rail distance.

- Remove foam packaging.
- Raise the opener onto a stepladder. You will need help at this point if the ladder is not tall enough.
- Open the door all the way and place a 2x4 on its side on the top section of the door beneath the rail.
- The top of the door should be level with the top of the motor unit. Do not position the opener more than 4" (10 cm) above this point.

CAUTION

To prevent damage to garage door, rest garage door opener rail on 2x4 placed on top section of door.

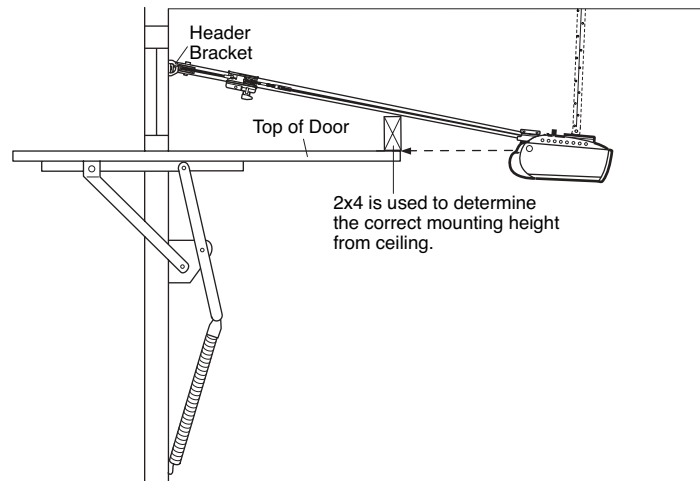
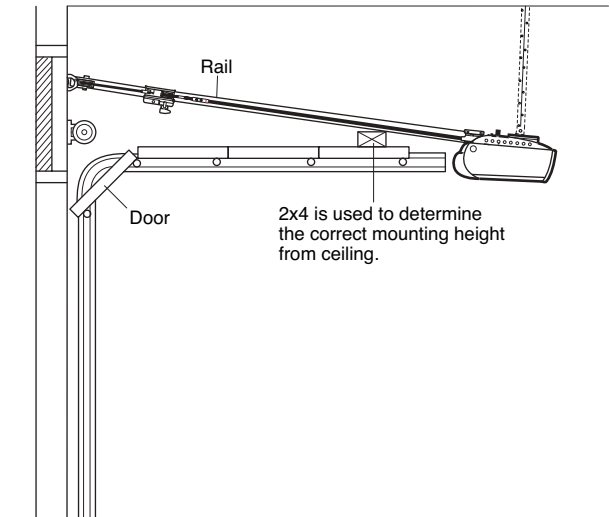

INSTALLATION STEP 5

Hang the Opener

Three representative installations are shown. Yours may be different. Hanging brackets should be angled, Figure 1, to provide rigid support. On finished ceilings, Figure 2, attach a sturdy metal bracket to structural supports before installing the opener. This bracket and fastening hardware are not provided.

Existing brackets from a previous installation may be fastened to the sides of the motor unit as in Figures 1 and 2, or to the mounting tabs as shown in Figure 3. Then continue with step 5 below.

1. Measure the distance from each side of the motor unit to the structural support.
2. Cut both pieces of the hanging bracket to required lengths.
3. Drill $\frac{3}{16}$ " pilot holes in the structural supports.
4. Attach one end of each bracket to a support with $\frac{5}{16}$ "- $18 \times 1\frac{7}{8}$ " lag screws.
5. Fasten the opener to the hanging brackets with $\frac{5}{16}$ "- $18 \times 7/8$ " hex bolts, lock washers and nuts.
6. Check to make sure the rail is centered over the door (or in line with the header bracket if the bracket is not centered above the door).
7. Remove the 2x4. Operate the door manually. If the door hits the rail, raise the header bracket.

NOTE: DO NOT connect power to opener at this time.

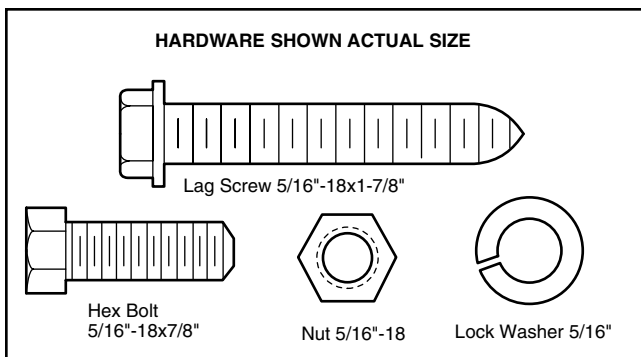

⚠ WARNING

To avoid possible **SERIOUS INJURY** from a falling garage door opener, fasten it **SECURELY** to structural supports of the garage. Concrete anchors **MUST** be used if installing any brackets into masonry.

Figure 1

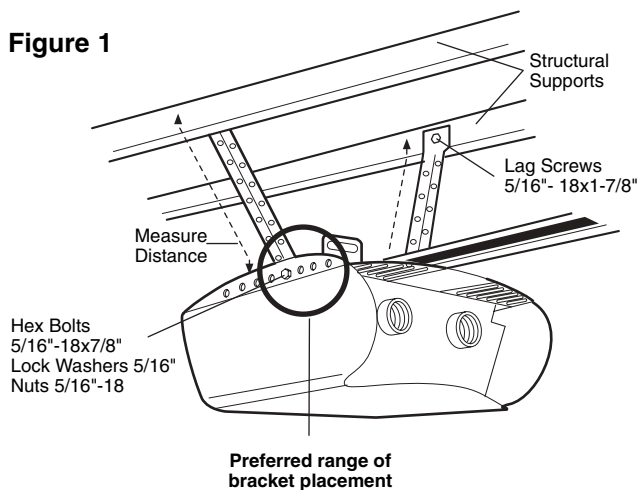

Figure 2

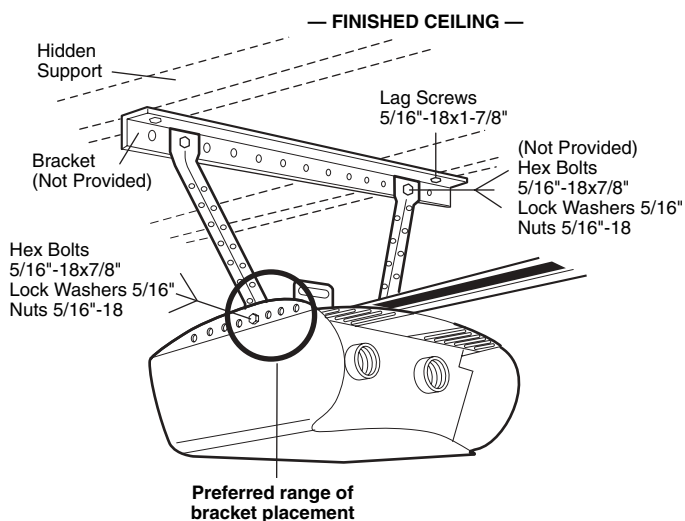
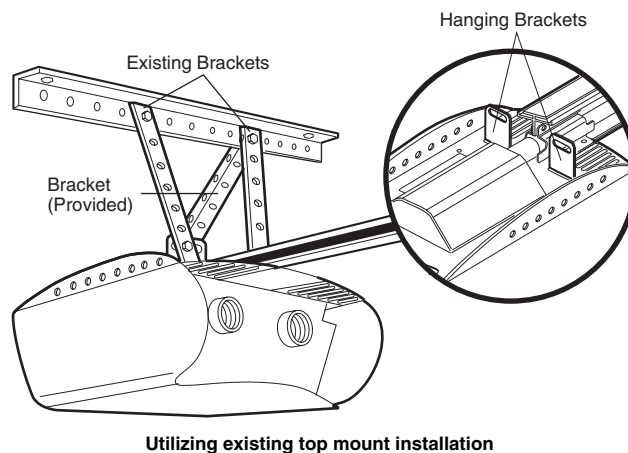

Figure 3



INSTALLATION STEP 6

Install the Door Control

Locate door control within sight of door, at a minimum height of 5 feet (1.5 m) where small children cannot reach, away from moving parts of door and door hardware. If installing into drywall, drill 5/32" holes and use the anchors provided. For pre-wired installations (as in new home construction), it may be mounted to a single gang box (Figure 2).

- Strip 7/16" (11 mm) of insulation from one end of bell wire and connect to the two screw terminals on back of door control by color: white wire to 2 and white/red wire to the 1.
- Remove cover by gently prying at slot in top of the cover with a small flat head screwdriver. Fasten with 6ABx1-1/4" self-tapping screws (drywall installation) or 6-32x1" machine screws (into gang box) as follows:
 - Install bottom screw, allowing 1/8" (3 mm) to protrude above wall surface.
 - Position bottom of door control on screw head and slide down to secure. Adjust screw for snug fit.
 - Drill and install top screw with care to avoid cracking plastic housing. **Do not overtighten.**
 - Insert top tabs and snap on cover.
- (For standard installation only)** Run bell wire up wall and across ceiling to motor unit. Use insulated staples to secure wire in several places. Do not pierce wire with a staple, creating a short or open circuit.
- Strip 7/16" (11 mm) of insulation from end of bell wire. Connect bell wire to the quick-connect terminals as follows: white to white and white/red to red.

NOTE: When connecting multiple door controls to the opener, twist same color wires together. Insert wires into quick-connect holes: white to white and red/white to red.

- Use tacks or staples to permanently attach entrapment warning label to wall near door control, and manual release/safety reverse test label in a prominent location on inside of garage door.

NOTE: DO NOT connect power and operate opener at this time. The trolley will travel to the full open position but will not return to the close position until the sensor beam is connected and properly aligned.

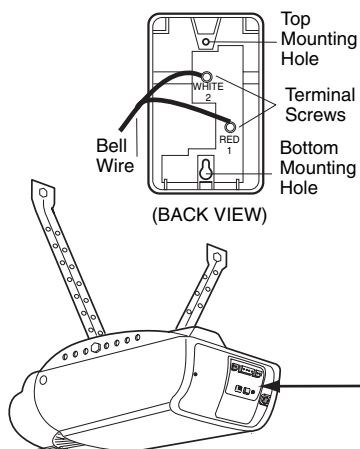

Figure 1

STANDARD WALL MOUNT

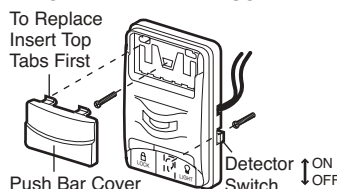
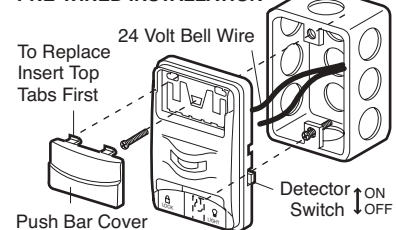

Figure 2

PRE-WIRED INSTALLATION



⚠️ WARNING

To prevent possible SERIOUS INJURY or DEATH from electrocution:

- Be sure power is not connected BEFORE installing door control.
- Connect ONLY to 24 VOLT low voltage wires.

To prevent possible SERIOUS INJURY or DEATH from a closing garage door:

- Install door control within sight of garage door, out of reach of children at a minimum height of 5 feet (1.5 m), and away from all moving parts of door.
- NEVER permit children to operate or play with door control push buttons or remote control transmitters.
- Activate door ONLY when it can be seen clearly, is properly adjusted, and there are no obstructions to door travel.
- ALWAYS keep garage door in sight until completely closed. NEVER permit anyone to cross path of closing garage door.

Outside Keylock Accessory Connections

To opener quick-connect terminals: white to white; white/red to red.

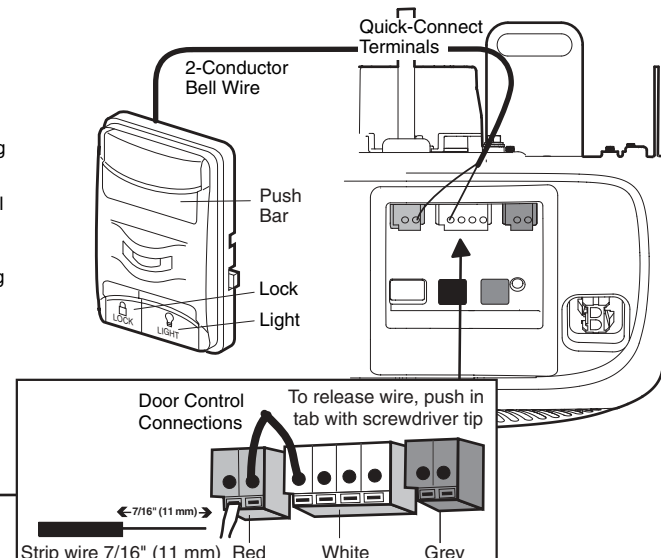
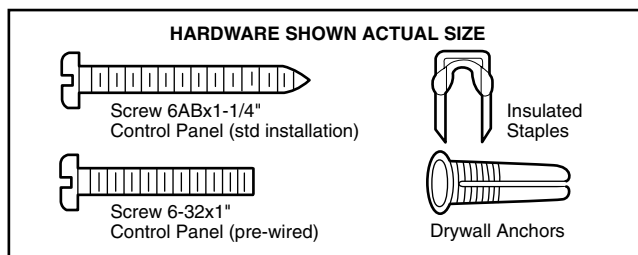

INSTALLATION STEP 7

Install the Lights

- Press the release tabs on both sides of lens. Gently rotate lens back and downward until the lens hinge is in the fully open position. Do not remove the lens.
- Install up to a 100 watt maximum light bulb in each socket. The lights will turn ON and remain lit for approximately 4-1/2 minutes when power is connected. Then the lights will turn OFF.
- Reverse the procedure to close the lens.
- If the bulbs burn out prematurely due to vibration, replace with a Garage Door Opener bulb.

NOTE: Use only standard light bulbs. The use of short neck or speciality light bulbs may overheat the endpanel or light socket.

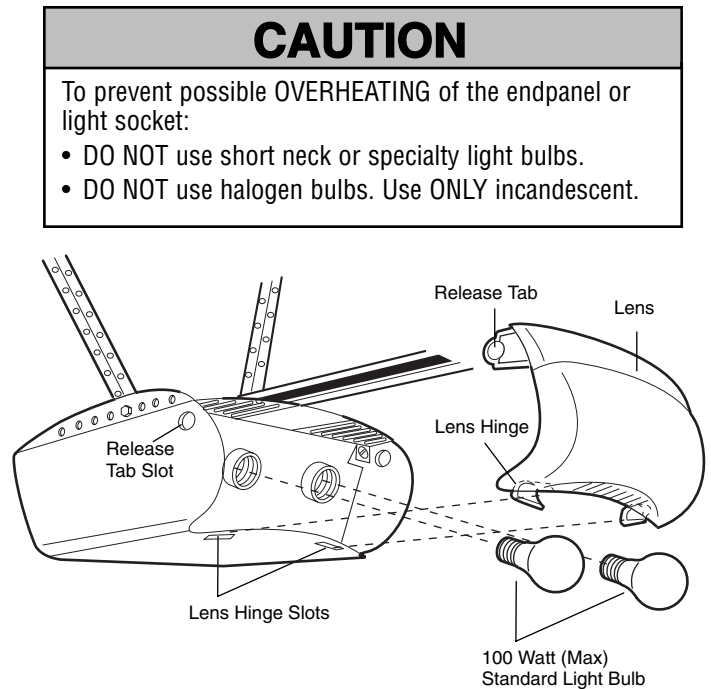

INSTALLATION STEP 8

Attach the Emergency Release Rope and Handle

- Thread one end of the rope through the hole in the top of the red handle so "NOTICE" reads right side up as shown. Secure with an overhand knot at least 1" (2.5 cm) from the end of the rope to prevent slipping.
- Thread the other end of the rope through the hole in the release arm of the outer trolley.
- Adjust rope length so the handle is 6 feet (1.81 m) above the floor. Ensure that the rope and handle clear the tops of all vehicles to avoid entanglement. Secure with an overhand knot.

NOTE: If it is necessary to cut the rope, heat seal the cut end with a match or lighter to prevent unraveling.

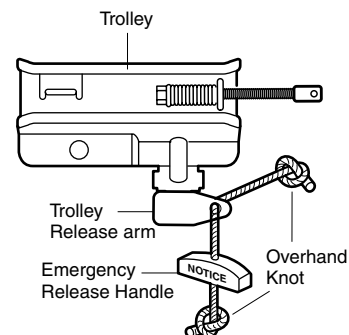
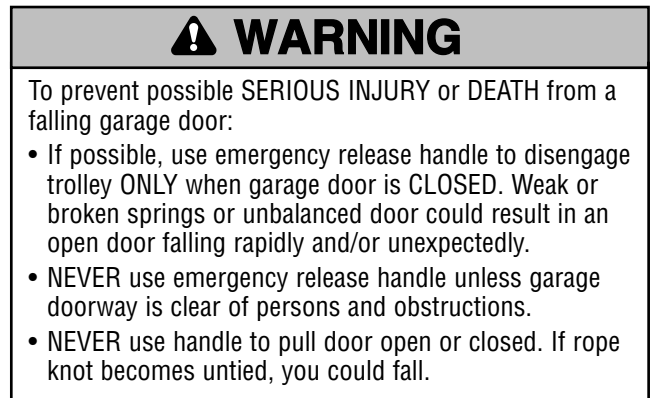

INSTALLATION STEP 9

Electrical Requirements

To avoid installation difficulties, do not run the opener at this time.

To reduce the risk of electric shock, your garage door opener has a grounding type plug with a third grounding pin. This plug will only fit into a grounding type outlet. If the plug doesn't fit into the outlet you have, contact a qualified electrician to install the proper outlet.

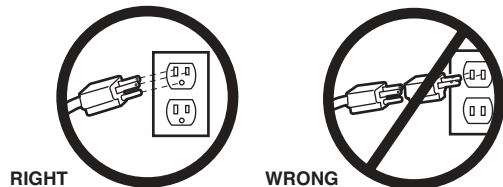

If permanent wiring is required by your local code, refer to the following procedure.

To make a permanent connection through the 7/8" hole in the top of the motor unit:

- Remove the motor unit cover screws and set the cover aside.
- Remove the attached 3-prong cord.
- Connect the black (line) wire to the screw on the brass terminal; the white (neutral) wire to the screw on the silver terminal; and the ground wire to the green ground screw. **The opener must be grounded.**
- Reinstall the cover.

To avoid installation difficulties, do not run the opener at this time.

WARNING

To prevent possible SERIOUS INJURY or DEATH from electrocution or fire:

- Be sure power is not connected to the opener, and disconnect power to circuit BEFORE removing cover to establish permanent wiring connection.
- Garage door installation and wiring MUST be in compliance with all local electrical and building codes.
- NEVER use an extension cord, 2-wire adapter, or change plug in any way to make it fit outlet. Be sure the opener is grounded.

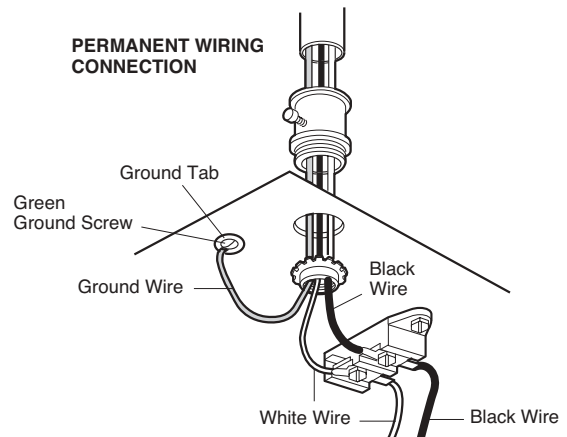

INSTALLATION STEP 10

Install The Protector System®

The safety reversing sensor must be connected and aligned correctly before the garage door opener will move in the down direction.

IMPORTANT INFORMATION ABOUT THE SAFETY REVERSING SENSOR

When properly connected and aligned, the sensor will detect an obstacle in the path of its electronic beam. The sending eye (with an amber indicator light) transmits an invisible light beam to the receiving eye (with a green indicator light). If an obstruction breaks the light beam while the door is closing, the door will stop and reverse to full open position, and the opener lights will flash 10 times.

The units must be installed inside the garage so that the sending and receiving eyes face each other across the door, no more than 6" (15 cm) above the floor. Either can be installed on the left or right of the door as long as the sun never shines directly into the receiving eye lens.

The mounting brackets are designed to clip onto the track of sectional garage doors without additional hardware.

⚠ WARNING

Be sure power is not connected to the garage door opener BEFORE installing the safety reversing sensor. To prevent SERIOUS INJURY or DEATH from a closing garage door:

- Correctly connect and align the safety reversing sensor. This required safety device MUST NOT be disabled.
- Install the safety reversing sensor so beam is NO HIGHER than 6" (15 cm) above garage floor.

If it is necessary to mount the units on the wall, the brackets must be securely fastened to a solid surface such as the wall framing. Extension brackets (see Accessories) are available if needed. If installing in masonry construction, add a piece of wood at each location to avoid drilling extra holes in masonry if repositioning is necessary.

The invisible light beam path must be unobstructed. No part of the garage door (or door tracks, springs, hinges, rollers or other hardware) may interrupt the beam while the door is closing.

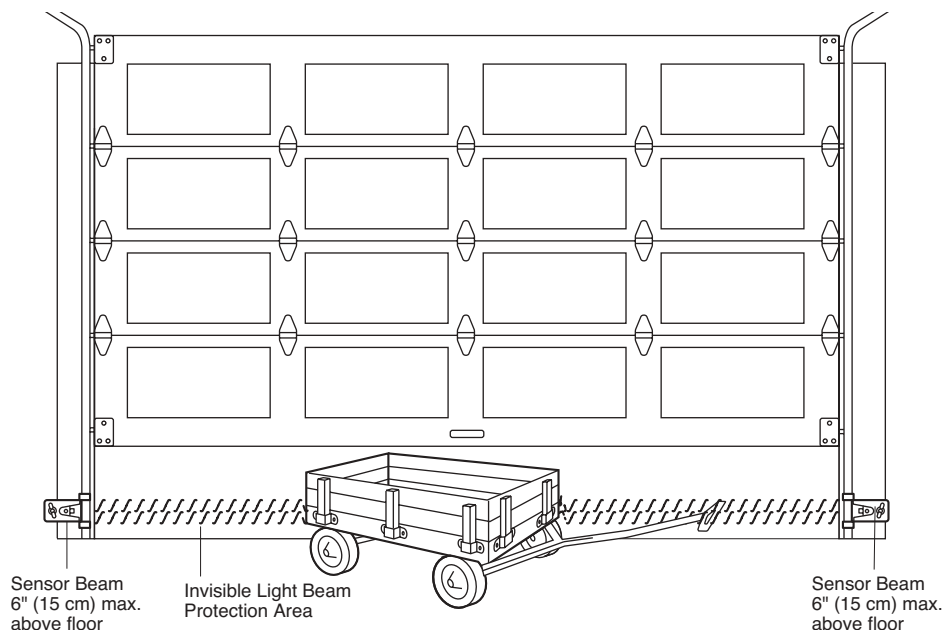

Facing the door from inside the garage

INSTALLING THE BRACKETS

Be sure power to the opener is disconnected.

Install and align the brackets so the sensors will face each other across the garage door, with the beam no higher than 6" (15 cm) above the floor. They may be installed in one of three ways, as follows.

Garage door track installation (preferred):

- Slip the curved arms over the rounded edge of each door track, with the curved arms facing the door. Snap into place against the side of the track. It should lie flush, with the lip hugging the back edge of the track, as shown in Figure 1.

If your door track will not support the bracket securely, wall installation is recommended.

Wall installation (Figure 2 & 3):

- Place the bracket against the wall with curved arms facing the door. Be sure there is enough clearance for the sensor beam to be unobstructed.
- If additional depth is needed, an extension bracket (See Accessories) or wood blocks can be used.
- Use bracket mounting holes as a template to locate and drill (2) 3/16" diameter pilot holes on the wall at each side of the door, no higher than 6" (15 cm) above the floor.
- Attach brackets to wall with lag screws (Not provided).
- If using extension brackets or wood blocks, adjust right and left assemblies to the same distance out from the mounting surface. Make sure all door hardware obstructions are cleared.

Floor installation (Figure 4):

- Use wood blocks or extension brackets (See Accessories) to elevate sensor brackets so the lenses will be no higher than 6" (15 cm) above the floor.
- Carefully measure and place right and left assemblies at the same distance out from the wall. Be sure all door hardware obstructions are cleared.
- Fasten to the floor with concrete anchors as shown.

Figure 1 DOOR TRACK MOUNT (RIGHT SIDE)

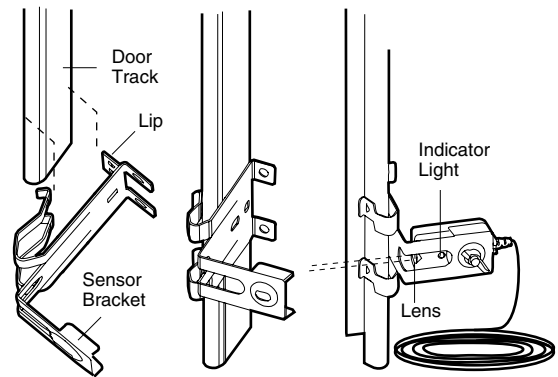

Figure 2

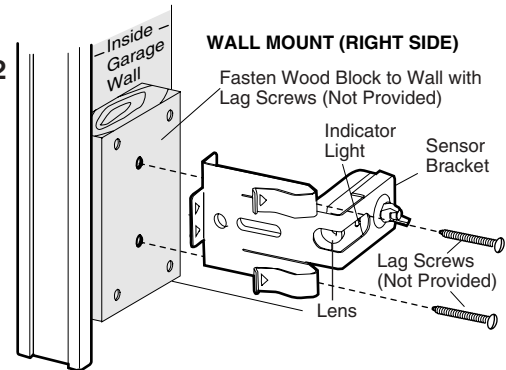

Figure 3

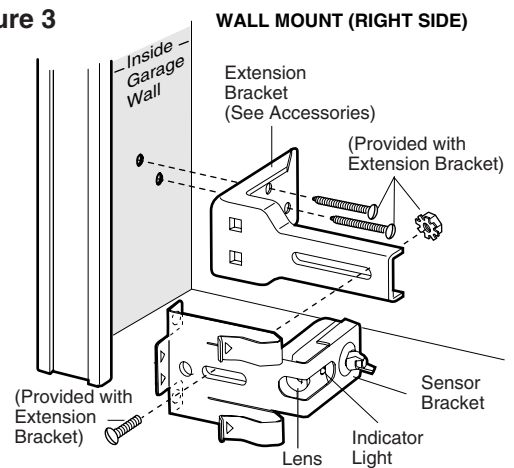
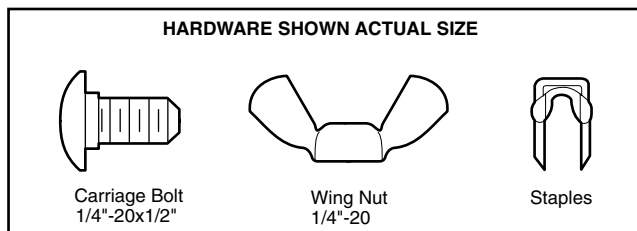
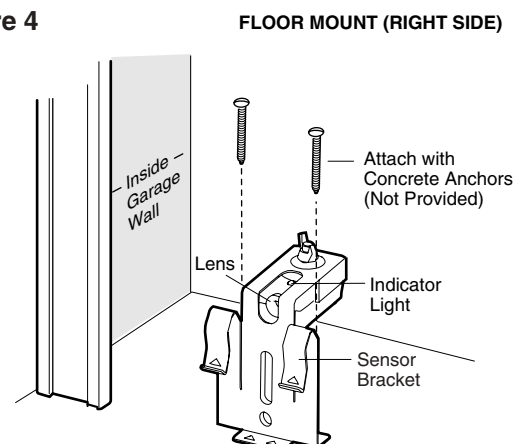

Figure 4



MOUNTING AND WIRING THE SAFETY SENSORS

- Slide a 1/4"-20x1/2" carriage bolt head into the slot on each sensor. Use wing nuts to fasten sensors to brackets, with lenses pointing toward each other across the door. Be sure the lens is not obstructed by a bracket extension (Figure 5).
- Finger tighten the wing nuts.
- Run the wires from both sensors to the opener. Use insulated staples to secure wire to wall and ceiling.
- Strip 7/16" (11 mm) of insulation from each set of wires. Separate white and white/black wires sufficiently to connect to the opener quick-connect terminals. Twist like colored wires together. Insert wires into quick-connect holes: white to white and white/black to grey (Figure 6).

ALIGNING THE SAFETY SENSORS

- Plug in the opener. The indicator lights in both the *sending* and *receiving eyes* will *glow steadily* if wiring connections and alignment are correct.

The *sending eye* amber indicator light will glow regardless of alignment or obstruction. If the green indicator light in the *receiving eye* is off, dim, or flickering (and the invisible light beam path is not obstructed), alignment is required.

- Loosen the *sending eye* wing nut and readjust, aiming directly at the *receiving eye*. Lock in place.
- Loosen the *receiving eye* wing nut and adjust sensor until it receives the sender's beam. When the green indicator light *glows steadily*, tighten the wing nut.

Figure 5

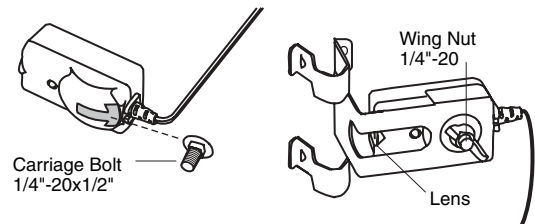

TROUBLESHOOTING THE SAFETY SENSORS

1. If the *sending eye* indicator light does not *glow steadily* after installation, check for:
 - Electric power to the opener.
 - A short in the white or white/black wires. These can occur at staples, or at opener connections.
 - Incorrect wiring between sensors and opener.
 - A broken wire.
2. If the *sending eye* indicator light *glows steadily* but the *receiving eye* indicator light doesn't:
 - Check alignment.
 - Check for an open wire to the *receiving eye*.
3. If the *receiving eye* indicator light is dim, realign either sensor.

NOTE: When the invisible beam path is obstructed or misaligned while the door is closing, the door will reverse. If the door is already open, it will not close. The opener lights will blink 10 times. See page 20.

Figure 6

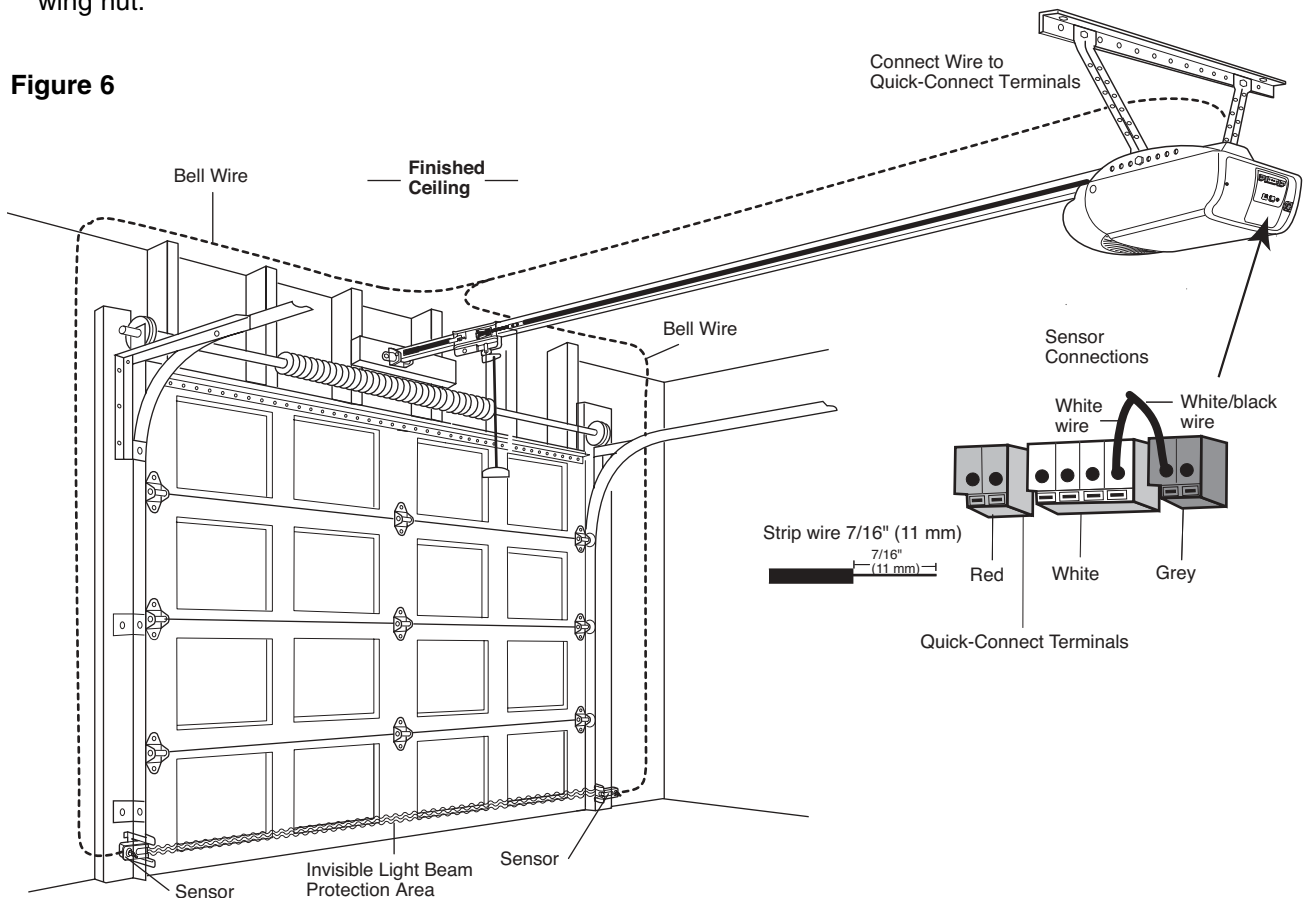

INSTALLATION STEP 11

Fasten the Door Bracket

Follow instructions which apply to your door type as illustrated below or on the following page.

A horizontal reinforcement brace should be long enough to be secured to two or three vertical supports. A vertical reinforcement brace should cover the height of the top panel.

Figure 1 shows one piece of angle iron as the horizontal brace. For the vertical brace, 2 pieces of angle iron are used to create a U-shaped support. The best solution is to check with your garage door opener installation door reinforcement kit.

NOTE: Many door reinforcement kits provide for direct attachment of the clevis pin and door arm. In this case you will not need the door bracket; proceed to Step 12.

SECTIONAL DOORS

1. Center the door bracket on the previously marked vertical centerline used for the header bracket installation. Note correct UP placement, as stamped inside the bracket.
2. Position the top edge of the bracket 2"-4" below the top edge of the door, OR directly below any structural support across the top of the door.
3. Mark, drill holes and install as follows, depending on your door's construction:

Metal or light weight doors using a vertical angle iron brace between the door panel support and the door bracket:

- Drill 3/16" fastening holes. Secure the door bracket using the two 1/4"-14x5/8" self-threading screws. (Figure 2A)
- Alternately, use two 5/16" bolts, lock washers and nuts (not provided). (Figure 2B)

Metal, insulated or light weight factory reinforced doors:

- Drill 3/16" fastening holes. Secure the door bracket using the self-threading screws (Figure 3).

Wood Doors:

- Use top and bottom or side to side door bracket holes. Drill 5/16" holes through the door and secure bracket with 5/16"x2" carriage bolts, lock washers and nuts (not provided). (Figure 4)

NOTE: The 1/4"-14x5/8" self-threading screws are not intended for use on wood doors.



CAUTION

Fiberglass, aluminum or lightweight steel garage doors **WILL REQUIRE** reinforcement BEFORE installation of door bracket. Contact your door manufacturer for reinforcement kit.

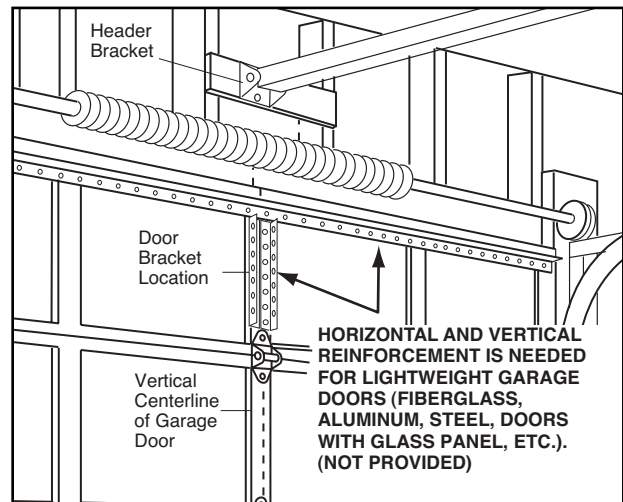

Figure 1

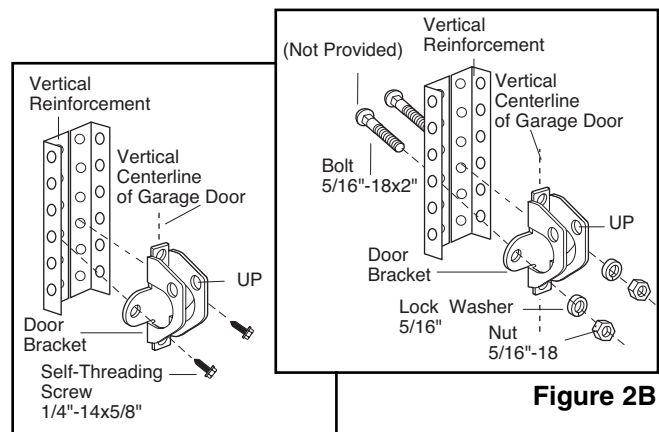

Figure 2A

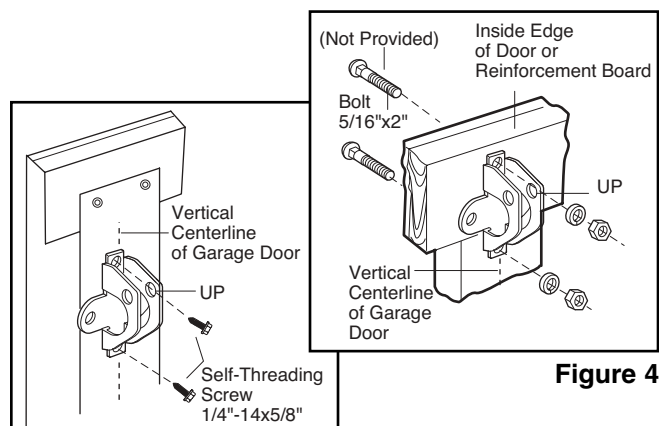

Figure 3

Figure 4

ONE-PIECE DOORS

Please read and comply with the warnings and reinforcement instructions on the previous page. They apply to one-piece doors also.

- Center the door bracket on the top of the door, in line with the header bracket as shown. Mark either the left and right, or the top and bottom holes.
- **Metal Doors:** Drill 3/16" pilot holes and fasten the bracket with the 1/4"-14x5/8" self-threading screws provided.
- **Wood Doors:** Drill 5/16" holes and use 5/16"x2" carriage bolts, lock washers and nuts (not provided) or 5/16"x1-1/2" lag screws (not provided) depending on your installation needs.

NOTE: The door bracket may be installed on the top edge of the door if required for your installation. (Refer to the dotted line optional placement drawing.)

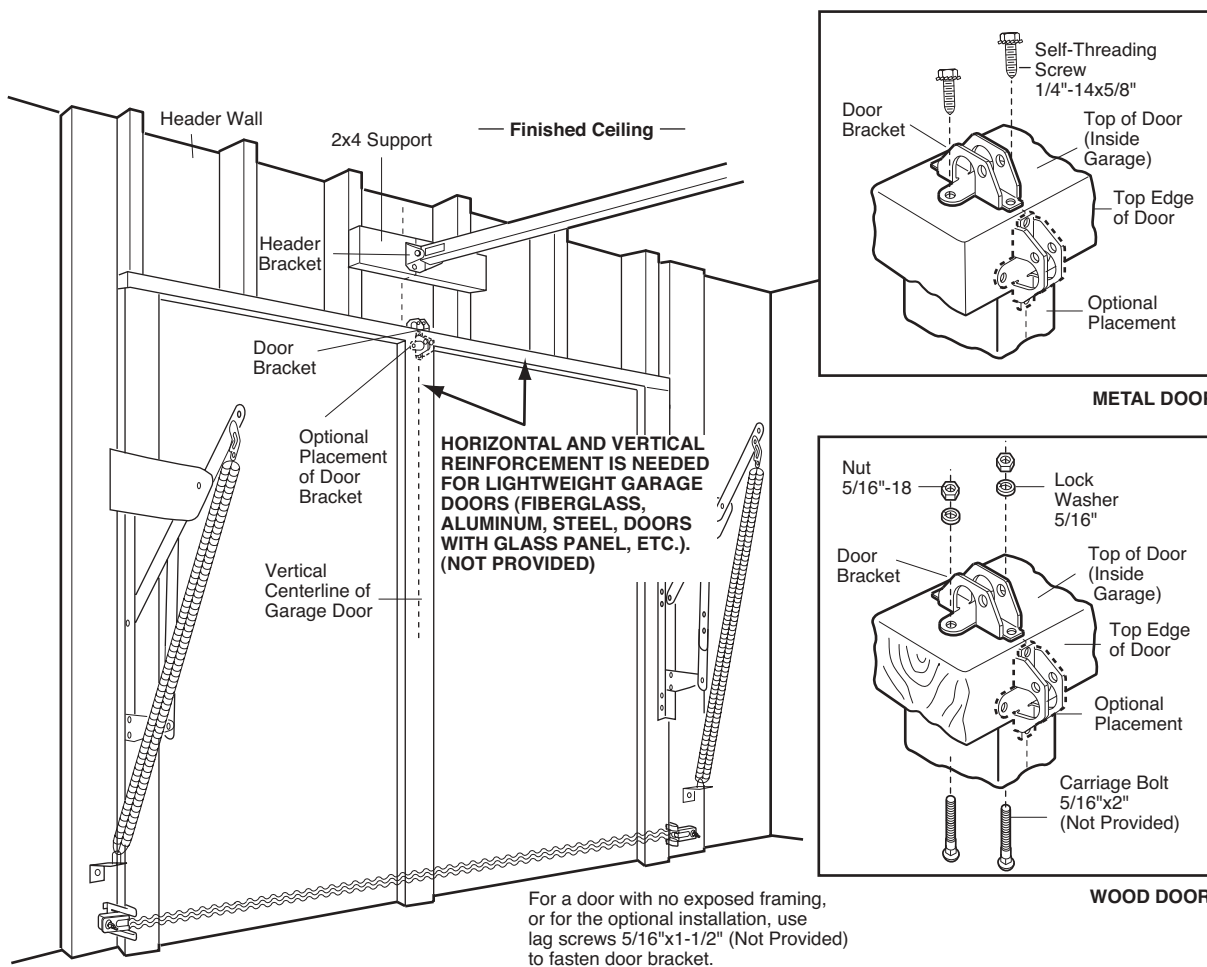
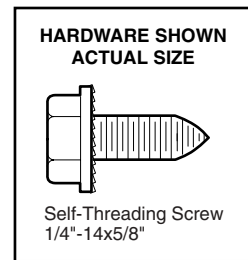

INSTALLATION STEP 12

Connect Door Arm to Trolley

Follow instructions which apply to your door type as illustrated below and on the following page.

SECTIONAL DOORS ONLY

- Make sure garage door is fully closed. Pull the emergency release handle to disconnect the outer trolley from the inner trolley. Slide the outer trolley back (away from the pulley) about 8" (20 cm) as shown in Figures 1, 2 and 3.

• Figure 1:

- Fasten straight door arm section to outer trolley with the 5/16"x1" clevis pin. Secure the connection with a ring fastener.
- Fasten curved section to the door bracket in the same way, using the 5/16"x1-1/4" clevis pin.

• Figure 2:

- Bring arm sections together. Find two pairs of holes that line up and join sections. Select holes as far apart as possible to increase door arm rigidity.

• Figure 3, Hole alignment alternative:

- If holes in curved arm are above holes in straight arm, disconnect straight arm. Cut about 6" (15 cm) from the solid end. Reconnect to trolley with cut end down as shown.
 - Bring arm sections together.
 - Find two pairs of holes that line up and join with bolts, lock washers and nuts.
- Pull the emergency release handle toward the opener at a 45° angle so that the trolley release arm is horizontal. Proceed to Adjustment Step 1, page 27. Trolley will re-engage automatically when opener is operated.

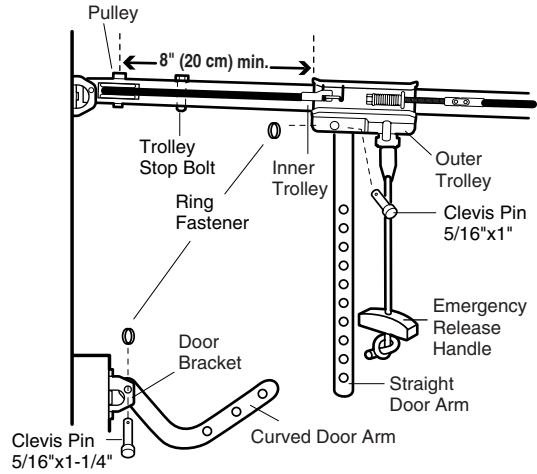

Figure 1

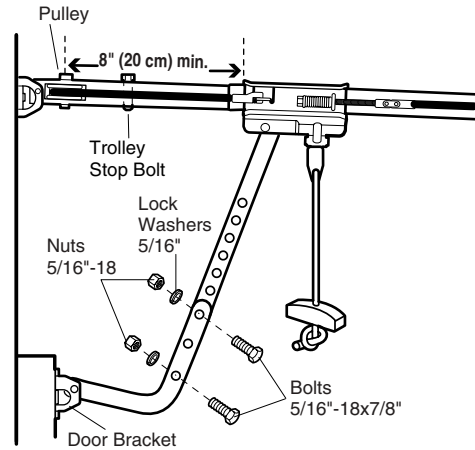

Figure 2

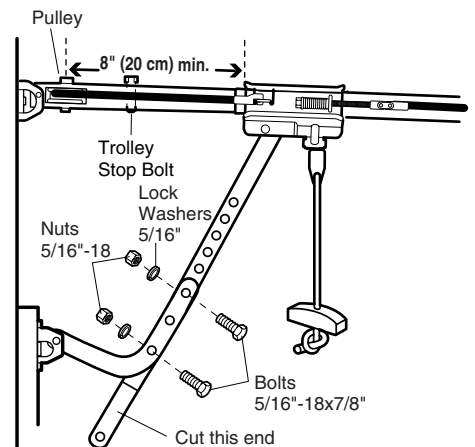
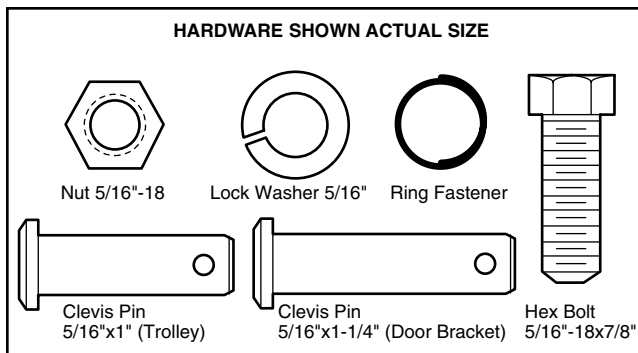
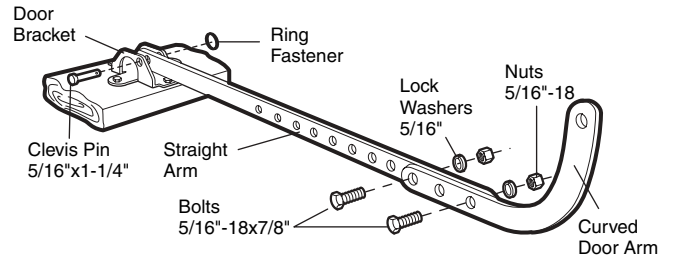

Figure 3

ALL ONE-PIECE DOORS

1. Assemble the Door Arm:

- Fasten the straight and curved door arm sections together to the longest possible length (with a 2 or 3 hole overlap).
- Make sure the garage door is fully closed. Connect the straight door arm section to the door bracket with the 5/16"x1-1/4" clevis pin.
- Secure with a ring fastener.
- Pull the emergency release handle, disconnecting the outer trolley from the inner trolley by pulling straight down on the emergency release handle and sliding the outer trolley back toward the motor unit.
- Connect the curved door arm section to the trolley using the 5/16"x1-1/4" clevis pin and ring fastener.



NOTE: Adjusting the limits on the following page:

- The trolley will automatically connect. If not, review the trolley lockout feature on page 31.
- When setting the up limit on the following page, the door should not have a "backward" slant when fully open as illustrated below. A slight backward slant will cause unnecessary bucking and/or jerking operation as the door is being opened or closed from the fully open position.

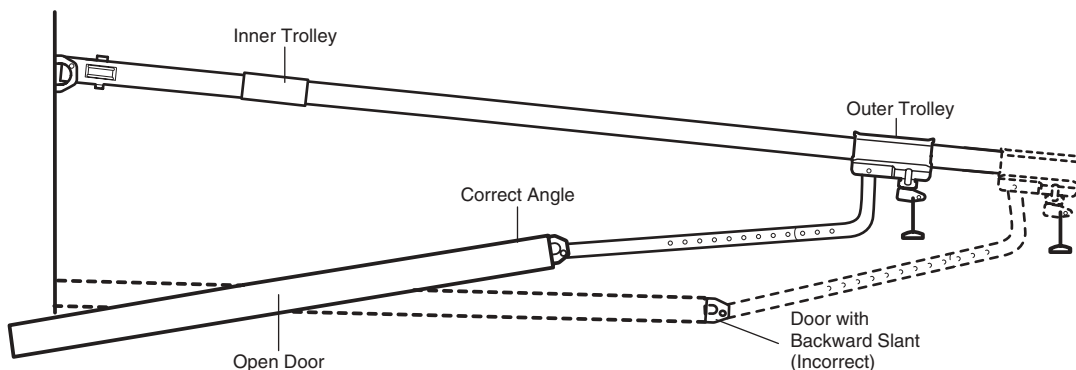
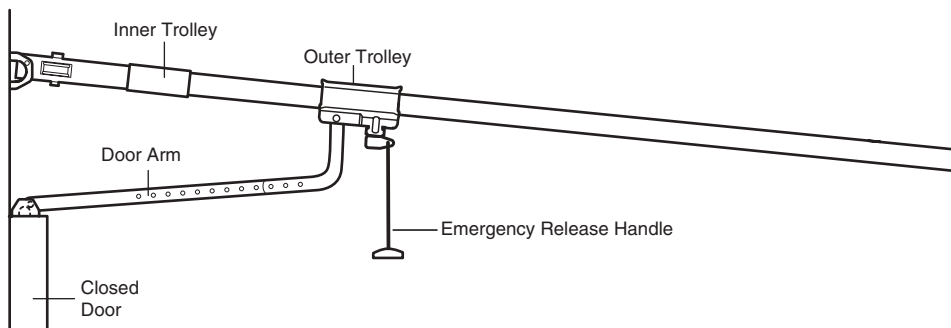

ADJUSTMENT STEP 1

Program the Travel Limits

Travel limits regulate the points at which the door will stop when moving up or down. Follow the steps below to set the limits.

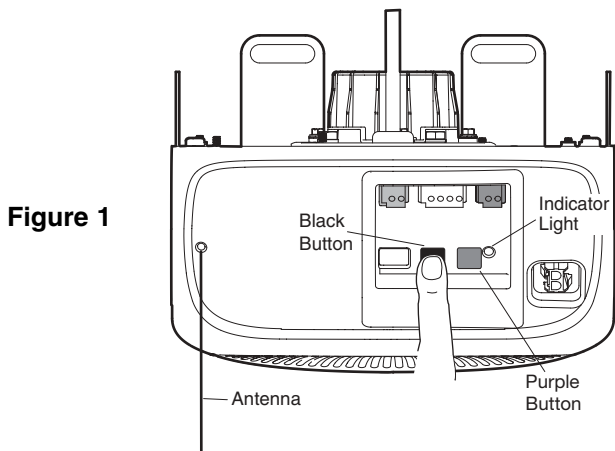

Figure 1

To program the travel limits:

1. Press and hold the black button until the yellow indicator light starts flashing slowly then release.
2. Push and hold the black button until the door reaches the desired UP (open) position (Figure 2). Adjust the position of the door by using the black and purple buttons. Black moves the door UP (open) and purple moves the door DOWN (close).

Check to be sure the door opens high enough for your vehicle.

NOTE: Refer to previous page for correct door position for one-piece door.

3. Push the remote control or door control (Figure 3). This sets the UP (open) limit and begins closing the door. Immediately press either the black or purple button; the door will stop.

Adjust the desired DOWN (close) limit position using the black and purple buttons (Figure 4). Check to be sure the door is fully closed without applying excessive pressure on the rail (rail should not bow upwards and the belt should not sag or droop below the rail). Push the remote control or door control (Figure 3). This sets the DOWN (close) limit and begins opening the door.

Figure 3

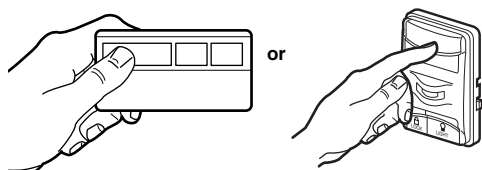

WARNING

Without a properly installed safety reversal system, persons (particularly small children) could be SERIOUSLY INJURED or KILLED by a closing garage door.

- Incorrect adjustment of garage door travel limits will interfere with proper operation of safety reversal system.
- After ANY adjustments are made, the safety reversal system MUST be tested. Door MUST reverse on contact with 1-1/2" high (3.8 cm) object (or 2x4 laid flat) on floor.

CAUTION

To prevent damage to vehicles, be sure fully open door provides adequate clearance.

Figure 2

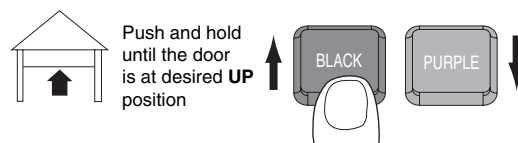
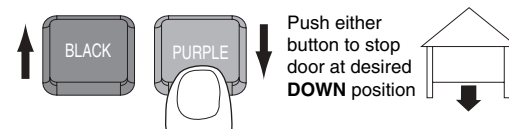

Figure 4



4. Open and close the door with the remote control or door control 2 or 3 times.

If the door stops in both the desired UP (open) and DOWN (close) positions, proceed to *Adjustment Step 2, Setting the Force*, followed by *Adjustment Step 3, Test the Safety Reversal System*.

ADJUSTMENT STEP 2

Setting the Force

The force setting button is located on the back panel of the motor unit. The force setting measures the amount of force required to open and close the door.

1. Locate the purple button on the back panel of unit (Figure 1).
2. Push the purple button twice to enter unit into Force Adjustment Mode (Figure 2). The LED (Indicator Light) will flash quickly.
3. Push the remote control or door control (Figure 3). The door will travel to the DOWN (close) position. Push the remote control or door control again, the door will travel to the UP (open) position. Push the remote control or door control a third time to send the door to the DOWN (close) position.

The LED (Indicator Light) will stop flashing when the force has been learned.

The unit has learned the forces required to open and close your door.

The door must travel through a complete cycle, UP and DOWN, in order for the force to be set properly. If the unit cannot open and close your door fully, inspect your door to insure that it is balanced properly and is not sticking or binding. See page 3, "Preparing your garage door."

WARNING

Without a properly installed safety reversal system, persons (particularly small children) could be SERIOUSLY INJURED or KILLED by a closing garage door.

- After ANY adjustments are made, the safety reversal system MUST be tested. Door MUST reverse on contact with 1-1/2" high (3.8 cm) object (or 2x4 laid flat) on floor.

Figure 1

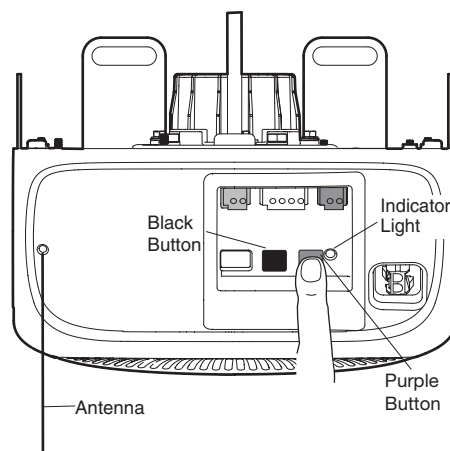

Figure 2

Push Purple button twice to enter unit into **Force Adjustment Mode**

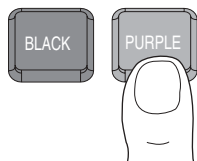
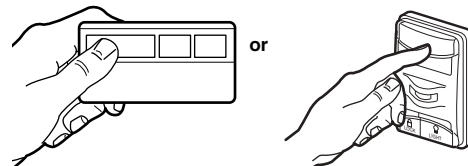

Figure 3



ADJUSTMENT STEP 3

Test the Safety Reversal System

TEST

- With the door fully open, place a 1-1/2" (3.8 cm) board (or a 2x4 laid flat) on the floor, centered under the garage door.
- Operate the door in the down direction. The door **must** reverse on striking the obstruction.

ADJUST

- If the door stops on the obstruction, it is not traveling far enough in the down direction. Complete Adjustment Steps 1 and 2 Programming the Limits and Forces.

NOTE: On a sectional door, make sure limit adjustments do not force the door arm beyond a straight up and down position. See Figure 3, page 25.

- Repeat the test.
- When the door reverses on the 1-1/2" (3.8 cm) board (or 2x4 laid flat), remove the obstruction and run the opener through 3 or 4 complete travel cycles to test adjustment.
- If the unit continues to fail the Safety Reverse Test, call for a trained door systems technician.

IMPORTANT SAFETY CHECK:

Test the Safety Reverse System after:

- Each adjustment of door arm length, limits, or force controls.
- Any repair to or adjustment of the garage door (including springs and hardware).
- Any repair to or buckling of the garage floor.
- Any repair to or adjustment of the opener.

ADJUSTMENT STEP 4

Test The Protector System®

- Press the remote control push button to open the door.
- Place the opener carton in the path of the door.
- Press the remote control push button to close the door. The door will not move more than an inch (2.5 cm), and the opener lights will flash.

The garage door opener will not close from a remote if the indicator light in either sensor is off (alerting you to the fact that the sensor is misaligned or obstructed).

If the opener closes the door when the safety reversing sensor is obstructed (and the sensors are no more than 6" [15 cm] above the floor), call for a trained door systems technician.

⚠ WARNING

Without a properly installed safety reversal system, persons (particularly small children) could be **SERIOUSLY INJURED** or **KILLED** by a closing garage door.

- Safety reversal system **MUST** be tested every month.
- After **ANY** adjustments are made, the safety reversal system **MUST** be tested. Door **MUST** reverse on contact with 1-1/2" high (3.8 cm) object (or 2x4 laid flat) on the floor.

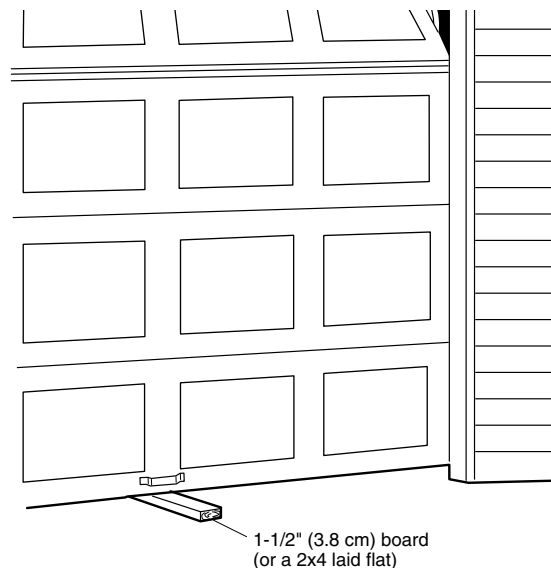

⚠ WARNING

Without a properly installed safety reversing sensor, persons (particularly small children) could be **SERIOUSLY INJURED** or **KILLED** by a closing garage door.

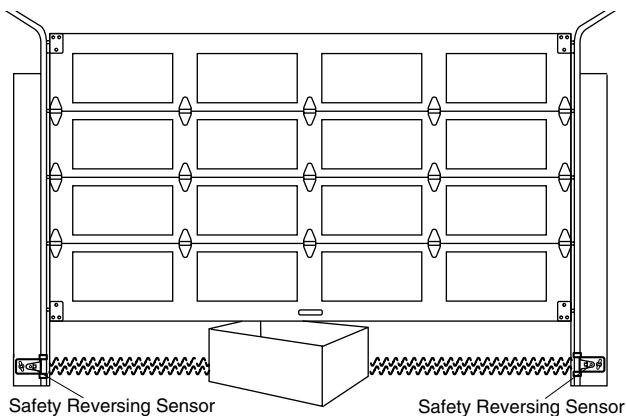

OPERATION

IMPORTANT SAFETY INSTRUCTIONS

WARNING

To reduce the risk of SEVERE INJURY or DEATH:

1. READ AND FOLLOW ALL WARNINGS AND INSTRUCTIONS.
2. ALWAYS keep remote controls out of reach of children. NEVER permit children to operate or play with garage door control push buttons or remote controls.
3. ONLY activate garage door when it can be seen clearly, it is properly adjusted, and there are no obstructions to door travel.
4. ALWAYS keep garage door in sight until completely closed. NO ONE SHOULD CROSS THE PATH OF THE MOVING DOOR.
5. NO ONE SHOULD GO UNDER A STOPPED, PARTIALLY OPENED DOOR.
6. If possible, use emergency release handle to disengage trolley ONLY when garage door is CLOSED. Weak or broken springs or unbalanced door could result in an open door falling rapidly and/or unexpectedly.
7. NEVER use emergency release handle unless garage doorway is clear of persons and obstructions.
8. NEVER use handle to pull garage door open or closed. If rope knot becomes untied, you could fall.
9. After ANY adjustments are made, the safety reversal system MUST be tested.
10. Safety reversal system MUST be tested every month. Garage door must reverse on contact with 1-1/2" (3.8 cm) high object (or a 2x4 laid flat) on the floor.
11. ALWAYS KEEP GARAGE DOOR PROPERLY BALANCED (see page 3). An improperly balanced door may not reverse when required and could result in SEVERE INJURY or DEATH.
12. All repairs to cables, spring assemblies and other hardware, all of which are under EXTREME tension, MUST be made by a trained door systems technician.
13. ALWAYS disconnect electric power to garage door opener BEFORE making any repairs or removing covers.
14. **SAVE THESE INSTRUCTIONS.**

Using Your Garage Door Opener

Your Security+® opener and hand-held remote control have been factory-set to a matching code which changes with each use, randomly accessing over 100 billion new codes. Your opener will operate with up to eight Security+® remote controls and one Security+® Keyless Entry System. If you purchase a new remote, or if you wish to deactivate any remote, follow the instructions in the *Programming* section.

Activate your opener with any of the following:

- *The hand-held Remote Control:* Hold the large push button down until the door starts to move.
- *The wall-mounted Door Control:* Hold the push button or bar down until the door starts to move.
- *The Keyless Entry (See Accessories):* If provided with your garage door opener, it must be programmed before use. See *Programming*.

When the opener is activated (with the safety reversing sensor correctly installed and aligned)

1. If open, the door will close. If closed, it will open.
2. If closing, the door will reverse.
3. If opening, the door will stop.
4. If the door has been stopped in a partially open position, it will close.
5. If obstructed while closing, the door will reverse. If the obstruction interrupts the sensor beam, the opener lights will blink for five seconds.

6. If obstructed while opening, the door will stop.
7. If fully open, the door will not close when the beam is broken. The sensor has no effect in the opening cycle.

If the sensor is not installed, or is misaligned, the door won't close from a hand-held remote. However, you can close the door with the Door Control, the Outdoor Key Switch, or Keyless Entry, *if you activate them until down travel is complete*. If you release them too soon, the door will reverse.

The opener lights will turn on under the following conditions: when the opener is initially plugged in; when power is restored after interruption; when the opener is activated.

They will turn off automatically after 4-1/2 minutes or provide constant light when the Light feature on the Motion Detecting Control Console is activated. Bulb size is 100 watts maximum.

Security+® light feature: Lights will also turn on when someone walks through the open garage door. With a Motion Detecting Control Panel, this feature may be turned off as follows: With the opener lights off, press and hold the light button for 10 seconds, until the light blinks. To restore this feature, start with the opener lights on, then press and hold the light button for 10 seconds until the light blinks.

Using the Wall-Mounted Door Control

THE MOTION DETECTING CONTROL CONSOLE

Press the lighted push button to open or close the door. Press again to reverse the door during the closing cycle or to stop the door while it's opening.

This door control contains a motion detector that will automatically turn on the light when it detects a person entering the garage. This feature can be easily turned off for extended work light use.

Light feature

Press the Light button to turn the opener light on or off. It will not control the opener lights when the door is in motion. If you turn it on and then activate the opener, the light will remain on for 4-1/2 minutes. Press again to turn it off sooner. The 4-1/2 minute interval can be changed to 1-1/2, 2-1/2, or 3-1/2 minutes as follows: Press and hold the Lock button until the light blinks (about 10 seconds). A single blink indicates that the timer is reset to 1-1/2 minutes. Repeat the procedure and the light will blink twice, resetting the timer to 2-1/2 minutes. Repeat again for a 3-1/2 minute interval, etc., up to a maximum of four blinks and 4-1/2 minutes.

When using the opener lights as working lights, we recommend that you first disable the motion sensor. See *Automatic Light Feature*, below.

Automatic Light Feature: The opener light will turn on automatically when a person enters the garage. When a person walks in front of the door control, the light will come on for five minutes, then shut off. This feature works by detecting body heat and may not work in temperatures around 100°F (37.7°C).

To disable this feature, slide the Detector Switch on the right side of the door control down (off).

We recommend that you disable the motion sensor when using the opener lights as working lights. Otherwise, they will turn off automatically if you are working beyond the sensors range.

Lock feature

Designed to prevent operation of the door from hand-held remote controls. However, the door will open and close from the Door Control, the Outdoor Key Switch and the Keyless Entry Accessories.

To activate, press and hold the Lock button for 2 seconds. The push button light will flash as long as the Lock feature is on.

To turn off, press and hold the Lock button again for 2 seconds. The push button light will stop flashing. The Lock feature will also turn off whenever the "learn" button on the motor unit panel is activated.

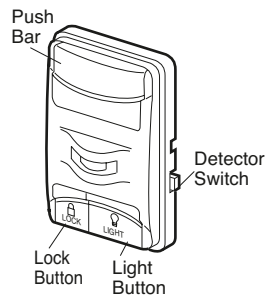

Additional feature when used with the 3-Button hand-held remote

To control the opener lights:

In addition to operating the door, you may program the remote to operate the lights.

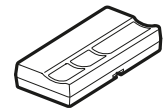

1. With the door closed, press and hold a small remote button that you want to control the light.
2. Press and hold the Light button on the door control.
3. While holding the Light button, press and hold the Lock button on the door control.
4. After the opener lights flash, release all buttons.

To Open the Door Manually

⚠ WARNING

To prevent possible SERIOUS INJURY or DEATH from a falling garage door:

- If possible, use emergency release handle to disengage trolley ONLY when garage door is CLOSED. Weak or broken springs or unbalanced door could result in an open door falling rapidly and/or unexpectedly.
- NEVER use emergency release handle unless garage doorway is clear of persons and obstructions.
- NEVER use handle to pull door open or closed. If rope knot becomes untied, you could fall.

DISCONNECT THE TROLLEY:

The door should be fully closed if possible. Pull down on the emergency release handle (so that the trolley release arm snaps into a vertical position) and lift the door manually. The *lockout feature* prevents the trolley from reconnecting automatically, and the door can be raised and lowered manually as often as necessary.

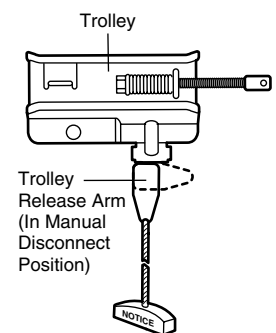

Lockout position (Manual disconnect)

TO RE-CONNECT THE TROLLEY:

Pull the emergency release handle toward the opener at an angle so that the trolley release arm is horizontal. The trolley will reconnect on the next UP or DOWN operation, either manually or by using the door control or remote.

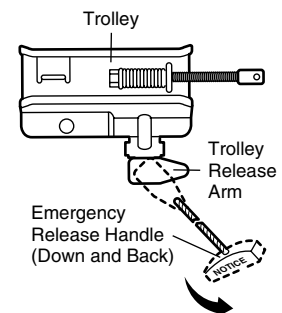

To reconnect

BATTERY BACKUP UNIT

Mounting the **battery backup unit (BBU)** can be done using one of two methods. The BBU can be mounted directly on top of the motor unit or it can be secured on a structural support just above it.

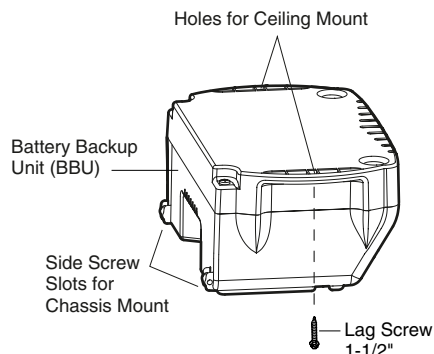

1. Mounting the BBU Directly to the Motor Unit.

- Position the BBU on top of the motor unit. Make sure the motor unit power cord is drawn out from beneath the BBU. The BBU should sit firmly on top of the motor unit. Adjust angle iron placement so that it is out of the way of the BBU's installation (Figure 1).
- Align the two screw slots on the BBU to the back chassis holes.
- Secure the BBU to each side of the chassis flanges with 3/4" screws provided.

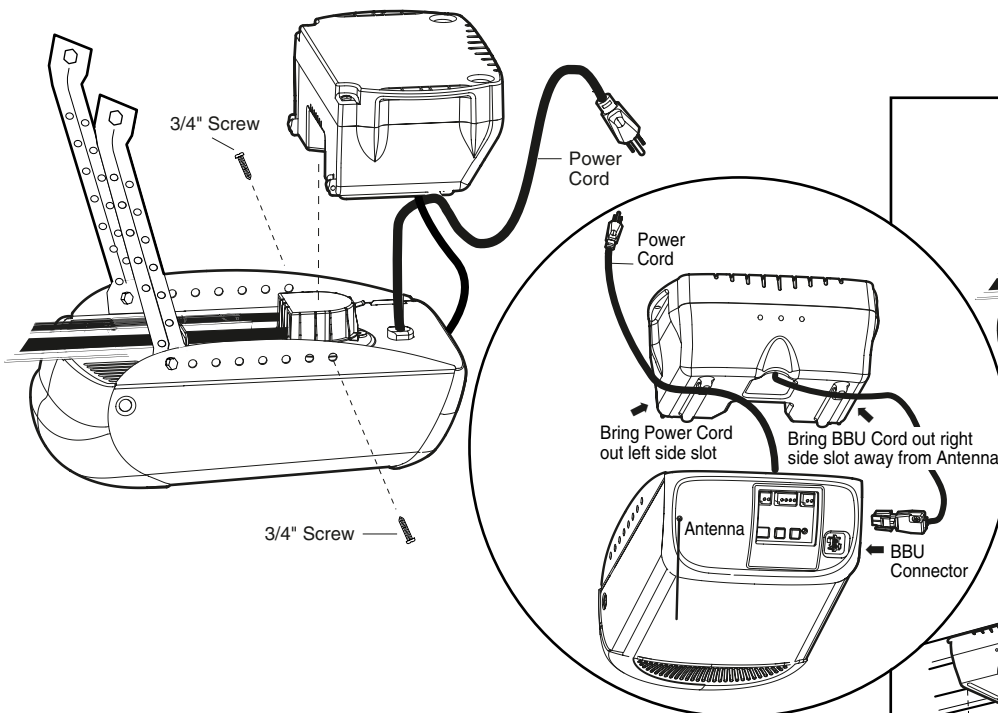

Figure 1

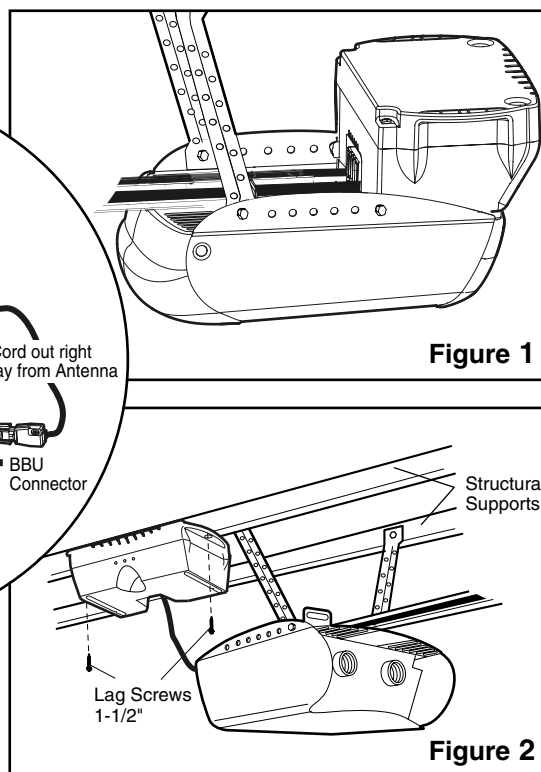

Figure 2

⚡ WARNING

To prevent possible **SERIOUS INJURY** or **DEATH** from electrocution, disconnect power to motor unit **BEFORE** proceeding.

2. Mounting the BBU Directly to the Ceiling Structural Support.

- After the motor unit has been installed, position the BBU above the motor unit to a structural support (joist) within BBU's cord length of 3' (.91 m) (Figure 2).
- Attach the BBU to the support by using the ceiling mount holes on either side of the BBU.
- Secure the BBU to the ceiling using 1-1/2" lag screws (provided).

3. Connect the BBU to the Motor Unit.

- Disconnect the motor unit from the electrical outlet.
- Connect the BBU cord into the connector on the right side of the end panel on the motor unit. Connect the motor unit into the electrical outlet. The BBU will activate and all LEDs will turn on for 3 seconds.
- The green LED will begin flashing indicating the BBU is charging from the motor unit.

IMPORTANT NOTE: Installation of BBU when permanent electrical power is not available (such as new construction and the electricity is not installed) may damage the batteries. Unplug BBU after testing to prevent damage.

WARNING

To reduce the risk of FIRE or INJURY to persons use only Chamberlain part #41B591 for replacement batteries.

OPERATING INSTRUCTIONS

1. Test the installed BBU with the motor unit.

To test the BBU, disconnect the motor unit power cord from the electrical outlet.

- A solid yellow LED indicates the BBU is operating on battery power.
- A flashing yellow LED with beep indicates the BBU is operating on battery power and that the battery charge is low.
- To test the BBU is functioning properly, open and close the garage door.
- Re-connect the motor unit power cord back into the electrical outlet.
- Verify that the green LED is flashing on the BBU (indicates that the BBU is now charging).
- Test completed.

2. Charge the battery.

- Allow the batteries 24 to 48 hours to fully charge before using the BBU system.

A fully charged BBU supplies 24V DC to the motor unit for one to two days of normal operation during an electrical power outage. If the battery voltage drops too low, the batteries will disconnect and the motor unit will no longer operate under battery power.

After the electrical power has been restored, the batteries will recharge within 48 hours. Under normal usage batteries will last 3 to 5 years.

To obtain maximum battery life and prevent damage, also disconnect the battery backup if you unplug the motor unit while on vacation or any other extended period of time.

NOTE: Door operation may be limited until batteries are fully charged. The motor unit's lights will not turn on during BBU mode.

Battery Backup Unit (BBU) Diagnostics

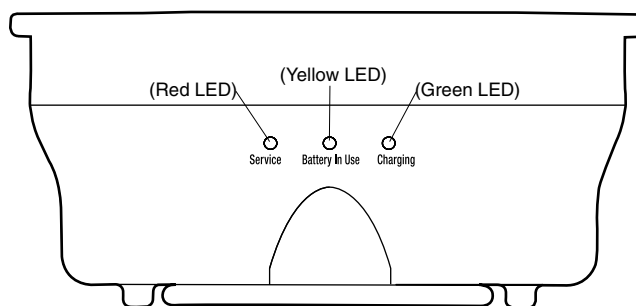

GREEN LED:

All systems are normal.

- A solid LED light indicates the batteries are fully charged.
- A flashing LED indicates the batteries are being charged.

NOTE: Batteries do not have to be fully charged to operate the motor unit.

YELLOW LED:

The motor unit has lost power and is operating off of the BBU.

- A solid LED with beep, sounding approximately every 2 seconds, indicates the motor unit is activating the door and is operating off of the BBU.
- A flashing LED with beep, sounding every 30 seconds, indicates batteries are low.
- Once the power is restored the BBU will recharge. This is indicated by a flashing green LED.

RED LED:

An error has been detected and the BBU will automatically shut off. The BBU will attempt to restart by reconnecting to the batteries. If the error is still present it will shut itself off again. This process will repeat every 5 minutes or until the error has been resolved. This is used to prevent further draining of the batteries.

- If a red LED remains on when the power is restored, and is accompanied by a beep sounding every 30 seconds, please call for service.

CARE OF YOUR OPENER

MAINTENANCE SCHEDULE

Once a Month

- Manually operate door. If it is unbalanced or binding, call a trained door systems technician.
- Check to be sure door opens & closes fully. Adjust limits if necessary. (See page 27)
- Repeat the safety reverse test. Make any necessary adjustments. (See Adjustment Step 3)

Once a Year

- Oil door rollers, bearings and hinges. The opener does not require additional lubrication. Do not grease the door tracks.

THE REMOTE CONTROL BATTERY

⚠ WARNING

To prevent possible **SERIOUS INJURY** or **DEATH**:

- **NEVER** allow small children near batteries.
- If battery is swallowed, immediately notify doctor.

The lithium battery should produce power for up to 5 years. To replace battery, use the visor clip or screwdriver blade to pry open the case as shown. Insert battery positive side up (+).

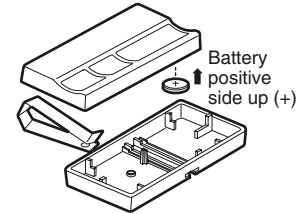

Dispose of old battery properly.

NOTICE: To comply with FCC and or Industry Canada rules (IC), adjustment or modifications of this receiver and/or transmitter are prohibited, except for changing the code setting or replacing the battery. **THERE ARE NO OTHER USER SERVICEABLE PARTS.** Tested to Comply with FCC Standards FOR HOME OR OFFICE USE. Operation is subject to the following two conditions: (1) this device may not cause harmful interference, and (2) this device must accept any interference received, including interference that may cause undesired operation.

HAVING A PROBLEM?

1. My door will not close and the light bulbs blink on my motor unit: The safety reversing sensor must be connected and aligned correctly before the garage door opener will move in the down direction.

- Verify the safety sensors are properly installed, aligned and free of any obstructions. Refer to *Installation Step 10: Install The Protector System®*.
- Check diagnostic LED for flashes on the motor unit then refer to the *Diagnostic Chart* on the following page.

2. My remotes will not activate the door:

- Verify your door control is not blinking. If it is blinking, deactivate the Lock Mode following the instructions for *Using the Wall-Mounted Door Control*.
- Reprogram remotes following the programming instructions. Refer to *Programming*.
- If remote will still not activate your door, check diagnostic LED for flashes on motor unit then refer to *Diagnostic Chart* on the following page.

3. My door reverses for no apparent reason:

Repeat safety reverse test after adjustments to force or travel limits. The need for occasional adjustment for the force and limit settings is normal. Weather conditions in particular can affect door travel.

- Manually check door for balance or any binding problems.
- Refer to *Adjustment Step 2, Setting the Force*.

4. My door reverses for no apparent reason after fully closing and touching the floor: Repeat safety reverse test after adjustments to force or travel limits. The need for occasional adjustment for the force and limit settings is normal. Weather conditions in particular can affect door travel.

- Refer to *Adjustment Step 1, Program the Travel Limits*. Decrease down travel by turning down limit adjustment screw clockwise.

5. My lights will not turn off when door is open:

- The garage door opener is equipped with a security light feature. This feature activates the light on when the safety sensor beam has been obstructed. Refer to Operation section; *Using the Wall-Mounted Door Control, Light Feature*.

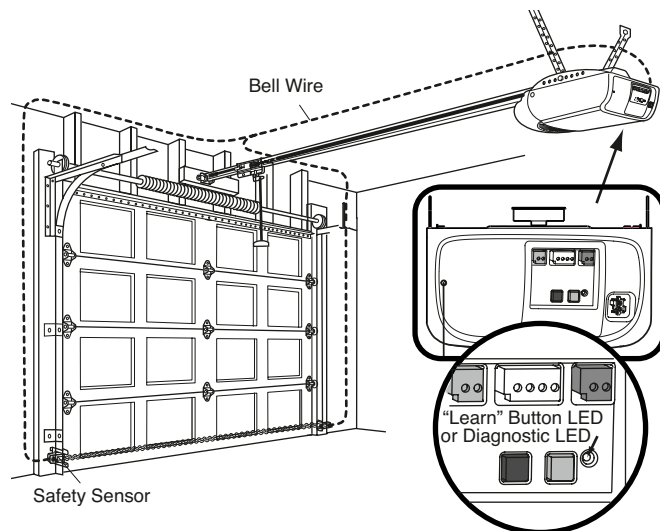

Sending Eye Safety Sensor
(Amber Indicator Light)

Receiving Eye Safety Sensor
(Green Indicator Light)

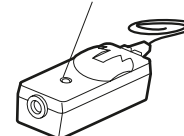
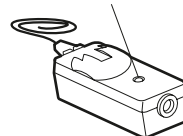

6. My motor unit hums briefly:

- First verify that the trolley is against the stop bolt.
- Release the door from the opener by pulling the Emergency Release Rope.
- Manually bring the door to a closed position.
- Loosen the belt by adjusting the *outer nut* 4 to 5 turns. This relieves the tension.
- Run the motor unit from the remote control or door control. The trolley should travel towards the door and stop. If the trolley re-engages with the door, pull the Emergency Release Rope to disengage.

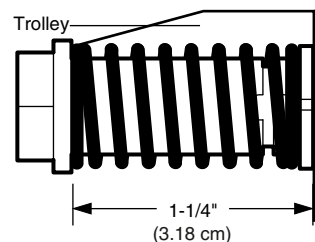

- Decrease the UP travel by turning the UP Travel adjustment screw 2 full turns *away* from the arrow.
- Re-Tighten the outer nut until the trolley spring is approximately 1-1/4" (3.18 cm) in length.
- If the trolley does not move away from the bolt, repeat the steps above.

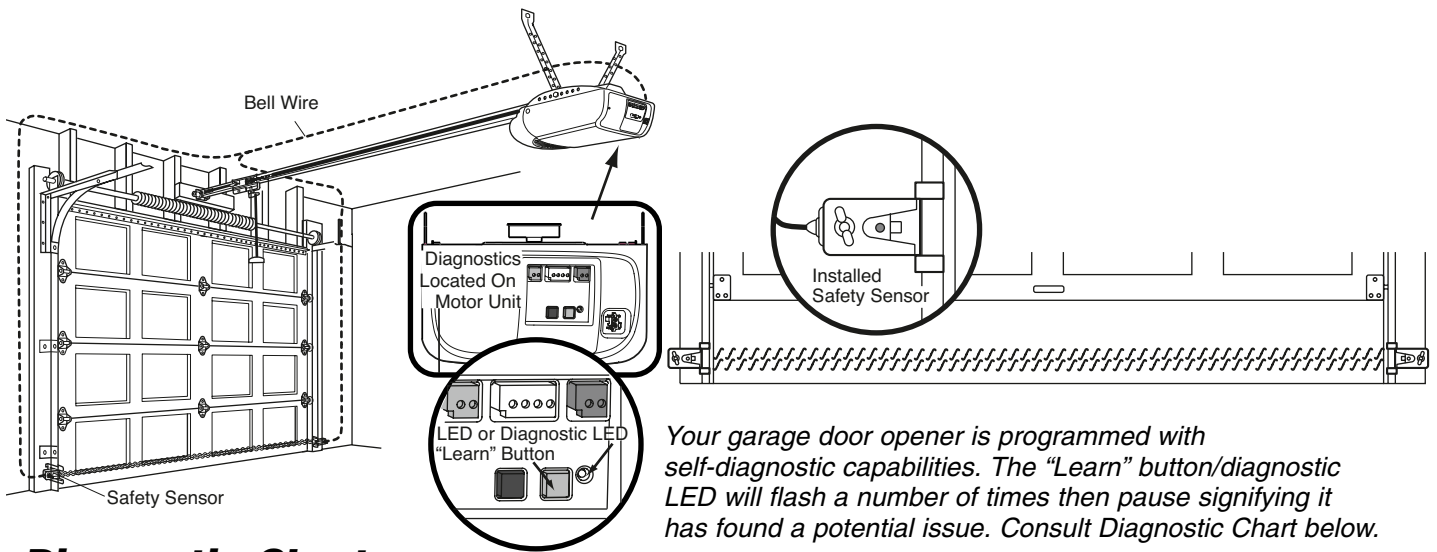

Your garage door opener is programmed with self-diagnostic capabilities. The "Learn" button/diagnostic LED will flash a number of times then pause signifying it has found a potential issue. Consult Diagnostic Chart below.

Diagnostic Chart

1 FLASH

Safety sensors wire open (broken or disconnected).

OR

2 FLASHES

Safety sensors wire shorted or black/white wire reversed.

3 FLASHES

Door control or wire shorted.

4 FLASHES

Safety Sensors slightly misaligned (dim or flashing LED).

5 FLASHES

Possible RPM sensor failure. Unplug to reset.

6 FLASHES

Motor Circuit Failure. Replace Receiver Logic Board.

● **Symptom: One or both of the Indicator lights on the safety sensors do not glow steady.**

- Inspect sensor wires for a short (staple in wire), correct wiring polarity (black/white wires reversed), broken or disconnected wires, replace/attach as needed.
- Disconnect all wires from back of motor unit.
- Remove sensors from brackets and shorten sensor wires to 1-2 ft (30-60 cm) from back each of sensor.
- Reattach sending eye to motor unit using shortened wires. If sending eye indicator light glows steadily, attach the receiving eye.
- Align sensors, if the indicator lights glow replace the wires for the sensors. If the sensor indicator lights do not light, replace the safety sensors.

● **Symptom: LED is not lit on door control.**

- Inspect door control/wires for a short (staple in wire), replace as needed.
- Disconnect wires at door control, touch wires together. If motor unit activates, replace door control.
- If motor unit does not activate, disconnect door control wires from motor unit. Momentarily short across red and white terminals with jumper wire. If motor unit activates, replace door control wires.

● **Symptom: Sending indicator light glows steadily, receiving indicator light is dim or flashing.**

- Realign receiving eye sensor, clean lens and secure brackets.
- Verify door track is firmly secured to wall and does not move.

● **Symptom: The motor unit does not operate or trolley is stuck on stop bolt = Motor unit hums briefly; RPM Sensor = Short travel 6-8" (15-20 cm).**

- Unplug unit to reset. Try to operate motor unit, check diagnostic code.
- If it is still flashing 5 times and motor unit moves 6-8" (15-20 cm), replace RPM sensor.
- If motor unit doesn't operate, replace logic board.

● **Symptom: Motor unit doesn't operate.**

- Replace logic board because motor rarely fails.

PROGRAMMING

NOTICE: If this Security+® garage door opener is operated with a non-rolling code transmitter, the technical measure in the receiver of the garage door opener, which provides security against code-theft devices, will be circumvented. The owner of the copyright in the garage door opener does not authorize the purchaser or supplier of the non-rolling code transmitter to circumvent that technical measure.

Your garage door opener has already been programmed at the factory to operate with your hand-held remote control. The door will open and close when you press the large push button.

Below are instructions for programming your opener to operate with additional Security+® remote controls.

To Add or Reprogram a Hand-held Remote Control

USING THE “LEARN” BUTTON

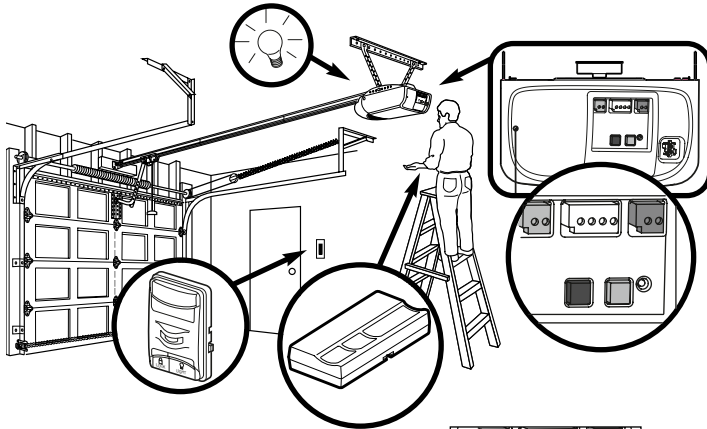

1. Press and release the “learn” button on the motor unit. The learn indicator light will glow steadily for 30 seconds.

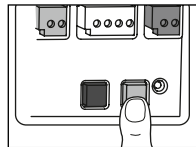

2. Within 30 seconds, press and hold the button on the hand-held remote* that you wish to operate your garage door.

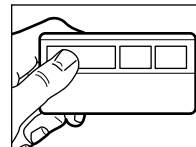

3. Release the button when the motor unit lights blink. It has learned the code. If light bulbs are not installed, two clicks will be heard.

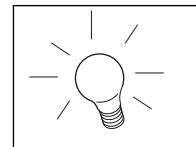

USING THE MOTION DETECTING CONTROL PANEL

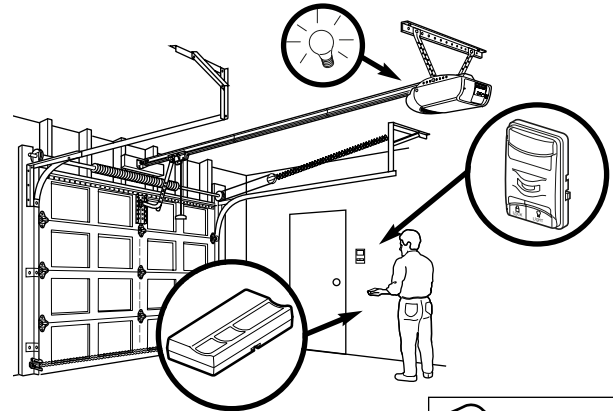

1. Press and hold the button on the hand-held remote* that you wish to operate your garage door.

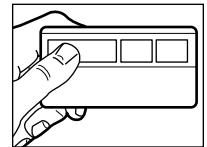

2. While holding the remote button, press and hold the LIGHT button on the Motion Detecting Door Control.

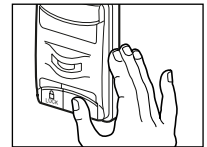

3. Continue holding both buttons while you press the push bar on the Motion Detecting Door Control (all three buttons are held).

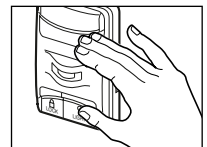

4. Release buttons when the motor unit lights blink. It has learned the code. If light bulbs are not installed, two clicks will be heard.

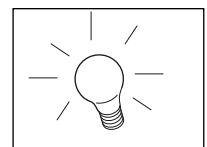

To Erase All Codes From Motor Unit Memory

To deactivate any unwanted remote, first erase all codes:

Press and hold the “learn” button on motor unit until the learn indicator light goes out (approximately 6 seconds). All previous codes are now erased. Reprogram each remote or keyless entry you wish to use.

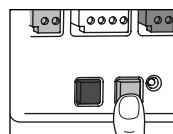

*3-Button Remotes

If provided with your garage door opener, the large button is factory programmed to operate it. Additional buttons on any Security+® 3-Button remote or compact remote can be programmed to operate other Security+® garage door openers.

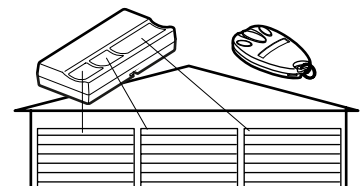

To Add, Reprogram or Change a Keyless Entry PIN

NOTE: Your new Keyless Entry must be programmed to operate your garage door opener.

USING THE "LEARN" BUTTON

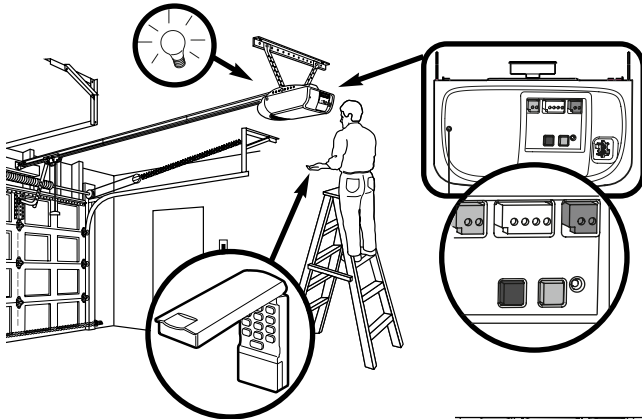

1. Press and release the "learn" button on motor unit. The learn indicator light will glow steadily for 30 seconds.
2. Within 30 seconds, enter a four digit personal identification number (PIN) of your choice on the keypad. Then press and hold the ENTER button.
3. Release the button when the motor unit lights blink. It has learned the code. If light bulbs are not installed, two clicks will be heard.

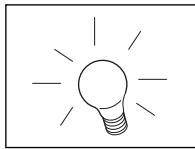
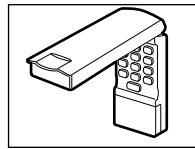
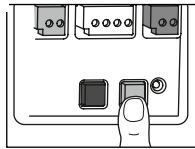

To change an existing, known PIN

If the existing PIN is known, it may be changed by one person without using a ladder.

1. Press the four buttons for the present PIN, then press and hold the # button.
The opener light will blink twice. Release the # button.

2. Press the new 4-digit PIN you have chosen, then press ENTER.

The motor unit lights will blink once when the PIN has been learned.

Test by pressing the new PIN, then press ENTER. The door should move.

To set a temporary PIN

You may authorize access by visitors or service people with a temporary 4-digit PIN. After a programmed number of hours or number of accesses, this temporary PIN expires and will no longer open the door. It can be used to *close* the door even after it has expired. To set a temporary PIN:

1. Press the four buttons for your personal entry PIN (not the last temporary PIN), then press and hold the * button.

The opener light will blink three times. Release the button.

USING THE MOTION DETECTING CONTROL PANEL

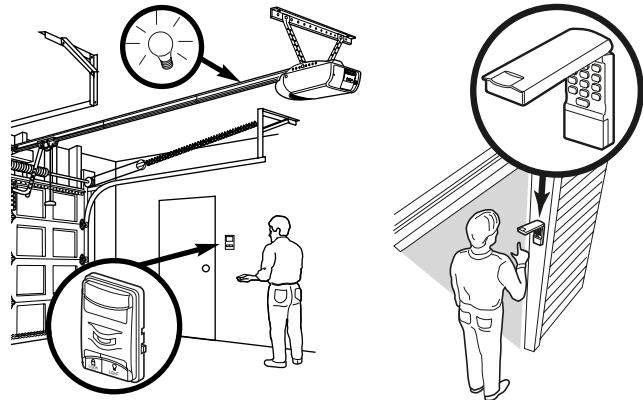

NOTE: This method requires two people if the Keyless Entry is already mounted outside the garage.

1. Enter a four digit personal identification number (PIN) of your choice on the keypad. Then press and hold ENTER.
2. While holding the ENTER button, press and hold the LIGHT button on the Motion Detecting Control Panel.
3. Continue holding the ENTER and LIGHT buttons while you press the push bar on the Motion Detecting Control Panel (all three buttons are held).
4. Release buttons when the motor unit lights blink. It has learned the code. If light bulbs are not installed, two clicks will be heard.

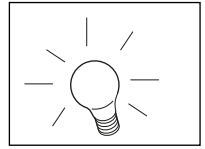
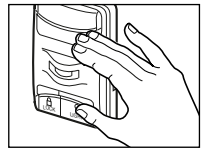
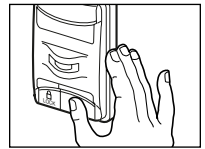
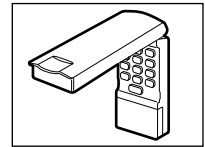

2. Press the temporary 4-digit PIN you have chosen, then press ENTER.

The opener light will blink four times.

3. To set the number of **hours** this temporary PIN will work, press the number of hours (up to 255), then press *.

OR

3. To set the number of **times** this temporary PIN will work, press the number of times (up to 255), then press #.

The opener light will blink once when the temporary PIN has been learned.

Test by pressing the four buttons for the temporary PIN, then press ENTER. The door should move. If the temporary PIN was set to a certain number of openings, remember that the test has used up one opening. To clear the temporary password, repeat steps 1-3, setting the number of hours or times to 0 in step 3.

REPAIR PARTS

Rail Assembly Parts

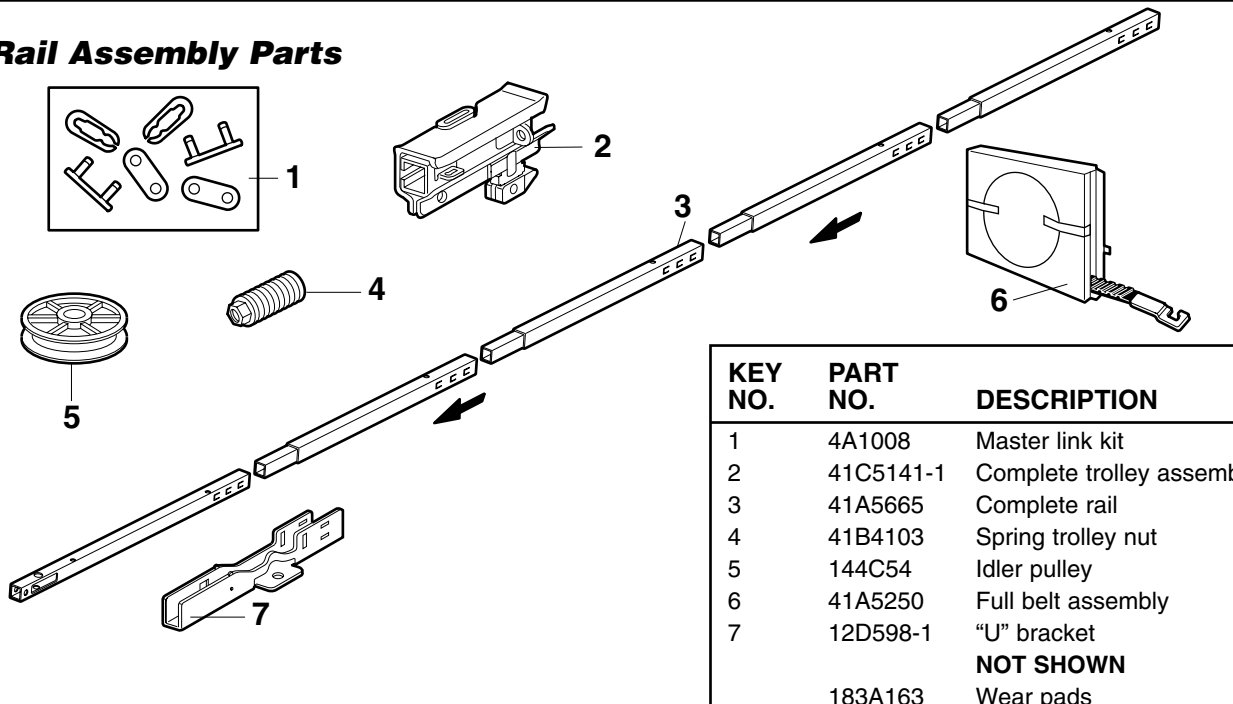

| KEY NO. | PART NO. | DESCRIPTION |
|---------|-----------|---------------------------|
| 1 | 4A1008 | Master link kit |
| 2 | 41C5141-1 | Complete trolley assembly |
| 3 | 41A5665 | Complete rail |
| 4 | 41B4103 | Spring trolley nut |
| 5 | 144C54 | Idler pulley |
| 6 | 41A5250 | Full belt assembly |
| 7 | 12D598-1 | "U" bracket |
| | | NOT SHOWN |
| | 183A163 | Wear pads |
| | 41A145 | Rail clip |

Installation Parts

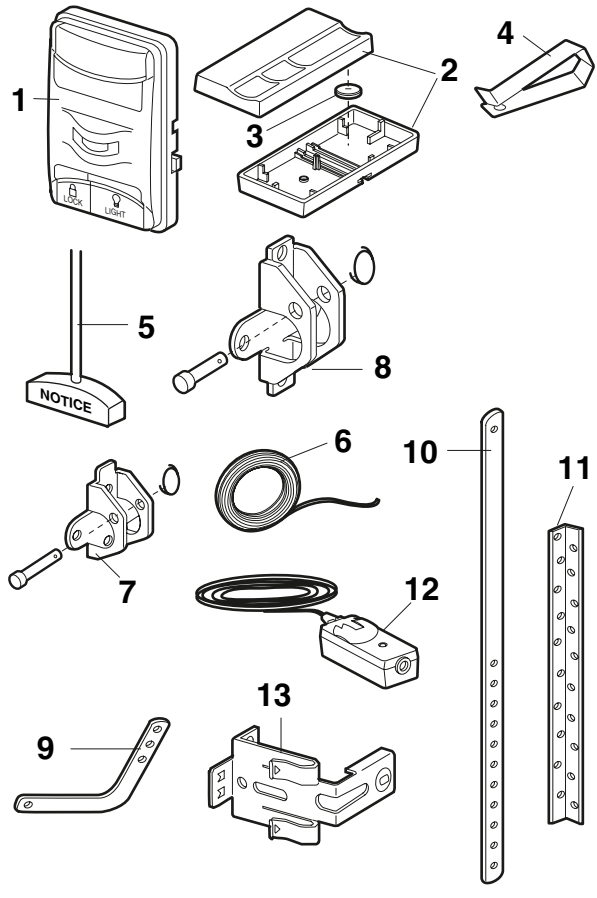

| KEY NO. | PART NO. | DESCRIPTION |
|---------|------------|--|
| 1 | 41C472-7 | Motion detecting control panel |
| 2 | 953D | 3-Button remote control |
| 3 | 10A20 | 3V 2032 Lithium battery |
| 4 | 29B137 | Visor clip |
| 5 | 41A2828 | Emergency release rope and handle assembly |
| 6 | 41B4494-1 | 2-Conductor bell wire: white and white/red |
| 7 | 41A5047-3 | Header bracket w/clevis pin and fastener |
| 8 | 41A5047-1 | Door bracket w/clevis pin and fastener |
| 9 | 178B35 | Curved door arm section |
| 10 | 178B34 | Straight door arm section |
| 11 | 12B776 | Hanging bracket |
| 12 | 41A5034 | Safety sensor kit: receiving and sending eyes with 3' (.91 m) 2-conductor bell wire attached |
| 13 | 41A5266-1 | Safety sensor bracket |
| | | NOT SHOWN |
| | 41A5257-9 | Installation hardware bag (includes hardware listed on page 7) |
| | 114A3056 | Owner's manual |
| | 114A3056SP | Owner's manual - Spanish |

Motor Unit Assembly Parts

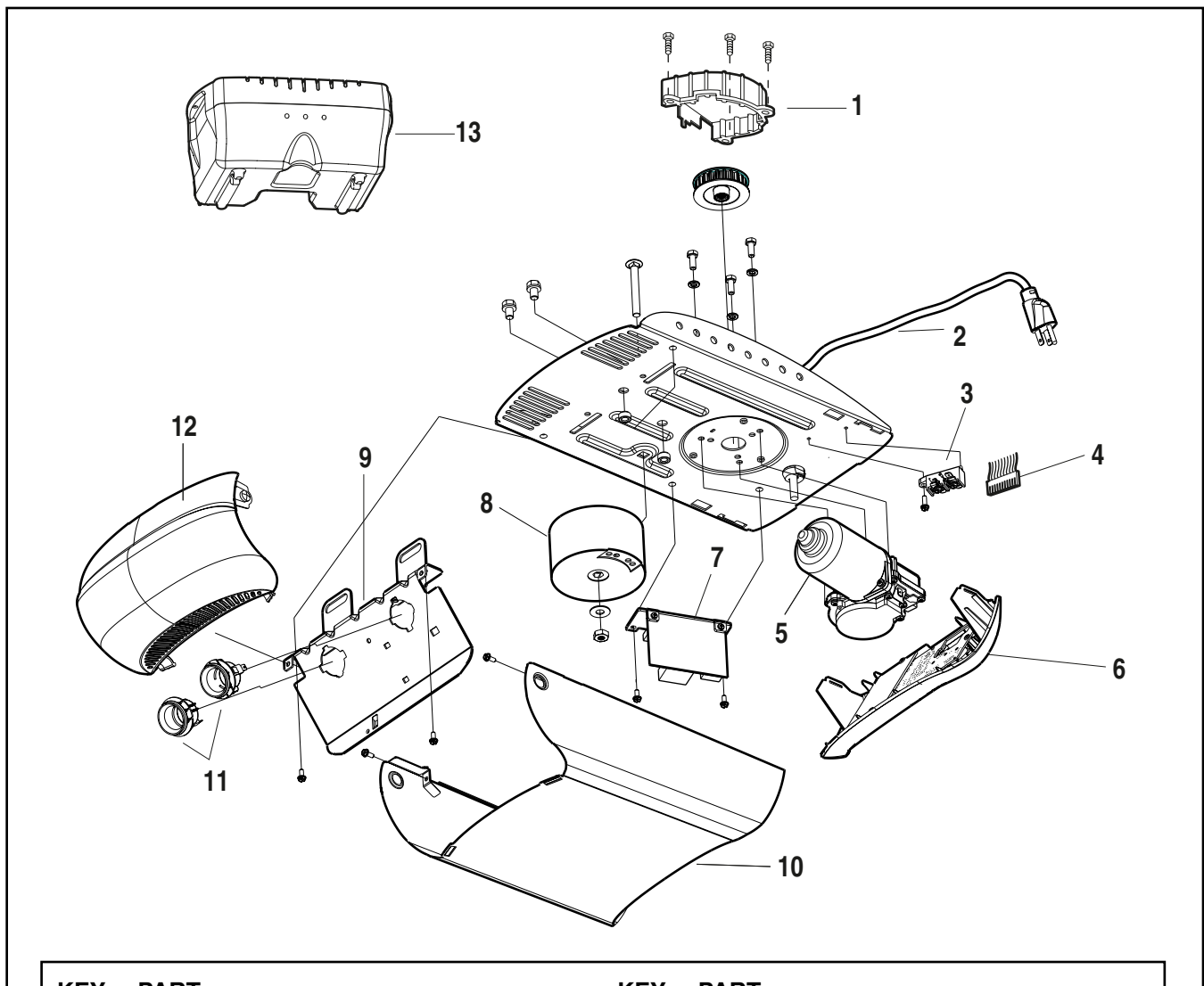

| KEY NO. | PART NO. | DESCRIPTION | KEY NO. | PART NO. | DESCRIPTION |
|---------|-----------|--|---------|------------|-------------------------------------|
| 1 | 41C76 | Belt cap and sprocket | 7 | 41B5351-7 | Power supply |
| 2 | 41B4245 | Line cord | 8 | 41C168 | Transformer and harness |
| 3 | 41B4375-3 | Terminal block w/screws | 9 | 41D630-2 | Bracket: light socket, limit switch |
| 4 | 41C5317-1 | Wire harness (logic) | 10 | 41A5490-17 | Cover |
| | 41C5839 | High voltage wire harness | 11 | 175C147 | Light socket |
| | 41C5806 | DC motor wire harness | 12 | 108D78 | Light lens |
| | 41C5418 | Light socket wire harness | 13 | 41A5893-1 | BBU housing ONLY |
| 5 | 41D605-1 | Motor 80kg/100kg | | | NOT SHOWN |
| 6 | 41DB001 | Receiver logic board assembly with end panel | | 41B591 | Battery replacement for BBU |
| | | | | 41A5726 | BBU circuit board |

ACCESSORIES

953D

3-Button SECURITY+® Remote Control:

Includes visor clip.

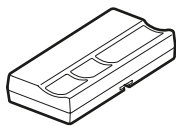

7702CB

Outside Quick Release:

Required for a garage with NO access door.



956D

3-Button Mini-Remote Control with SECURITY+®:

With key ring and fastening strip.



760CB

Outdoor Key Switch:

Operates the garage door automatically from outside when remote control is not handy.

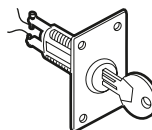

940D

SECURITY+® Keyless Entry:

Enables homeowner to operate garage door opener from outside by entering a password on a specially designed keyboard. Also can add a temporary password for visitors or service persons. This temporary password can be limited to a programmable number of hours or entries.

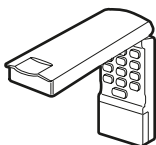

8808CB

8 Foot (2.4 m) Rail Extension:

To allow an 8 foot (2.4 m) door to open fully.

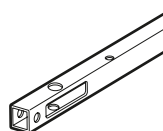

945CB

Multi-Button Door Control Panel:

Provides a Lock feature which prevents operation of garage door opener from portable remotes and a Light feature for constant light.



8810CB

10 Foot (3 m) Rail Extension:

To allow a 10 foot (3 m) door to open fully.

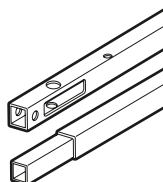

935CB

Motion Detecting Control Panel:

Multi-Button door control with motion sensor that automatically turns opener lights on for 5 minutes when it detects a person entering the garage. Sensor can be easily deactivated when desired.



41A5281

Extension Brackets:

(Optional) For safety sensor installation onto the wall or floor. To order call: 1-800-528-9131.

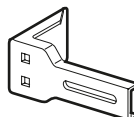

CLDM1

Garage Door Monitor:

Monitors the status of your garage door from inside your home.



CLLAT

Remote Light Control:

Enables homeowner to turn on a lamp, television or other appliance from their car with their garage door opener remote or from anywhere in their home with an additional Chamberlain Security+® remote.

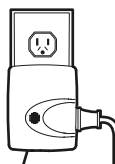

CHAMBERLAIN SERVICE IS ON CALL

OUR LARGE SERVICE ORGANIZATION
SPANS AMERICA

INSTALLATION AND SERVICE INFORMATION IS AS
NEAR AS YOUR TELEPHONE SEVEN DAYS A WEEK.
SIMPLY DIAL OUR TOLL FREE NUMBER:

1-800-528-9131

HOURS: (Central Std. Time)
5:00 A.M. TO 7:00 P.M. - Monday through Friday
8:00 A.M. TO 6:00 P.M. - Saturday
8:00 A.M. TO 4:30 P.M. - Sunday

www.chamberlain-diy.com

For professional installation, parts and service,
contact your local CHAMBERLAIN dealer. Look for him
in the Yellow Pages, or call our Service number for a
list of dealers in your area.

HOW TO ORDER REPAIR PARTS

Selling prices will be furnished on request, or parts will
be shipped at prevailing prices and you will be billed
accordingly.

WHEN ORDERING REPAIR PARTS, ALWAYS GIVE
THE FOLLOWING INFORMATION:

- PART NUMBER
- PART NAME
- MODEL NUMBER

ADDRESS ORDERS TO:

THE CHAMBERLAIN GROUP, INC.
Technical Support Group
6020 S. Country Club Road
Tucson, Arizona 85706

SERVICE INFORMATION

TOLL FREE NUMBER:

1-800-528-9131

CHAMBERLAIN® ONE-YEAR LIMITED WARRANTY 10 YEAR BELT LIMITED WARRANTY & LIFETIME MOTOR LIMITED WARRANTY

The Chamberlain Group, Inc. ("Seller") warrants to the first retail purchaser of this product, for the residence in which this product is originally installed, that it is free from defect in materials and/or workmanship for a period of one year from the date of purchase, [and that the belt is free from defect in materials and/or workmanship for a period of 10 years from the date of purchase and that the motor is free from defect in materials and/or workmanship for the lifetime of the product]. The proper operation of this product is dependent on your compliance with the instructions regarding installation, operation, maintenance and testing. Failure to comply strictly with those instructions will void this limited warranty in its entirety.

If, during the limited warranty period, this product appears to contain a defect covered by this limited warranty, call 1-800-528-9131, toll free, before dismantling this product. Then send this product, pre-paid and insured, to our service center for warranty repair. You will be advised of shipping instructions when you call. Please include a brief description of the problem and a dated proof-of-purchase receipt with any product returned for warranty repair. Products returned to Seller for warranty repair, which upon receipt by Seller are confirmed to be defective and covered by this limited warranty, will be repaired or replaced (at Seller's sole option) at no cost to you and returned pre-paid. Defective parts will be repaired or replaced with new or factory-rebuilt parts at Seller's sole option.

ALL IMPLIED WARRANTIES FOR THE PRODUCT, INCLUDING BUT NOT LIMITED TO ANY IMPLIED WARRANTIES OF MERCHANTABILITY AND FITNESS FOR A PARTICULAR PURPOSE, ARE LIMITED IN DURATION TO THE ONE YEAR LIMITED WARRANTY PERIOD SET FORTH ABOVE [EXCEPT THE IMPLIED WARRANTIES WITH RESPECT TO THE BELT AND MOTOR, WHICH ARE LIMITED IN DURATION TO THE BELT 10 YEARS AND MOTOR LIFETIME LIMITED WARRANTY PERIOD FOR THE BELT AND MOTOR], AND NO IMPLIED WARRANTIES WILL EXIST OR APPLY AFTER SUCH PERIOD. Some States do not allow limitations on how long an implied warranty lasts, so the above limitation may not apply to you. THIS LIMITED WARRANTY DOES NOT COVER NON-DEFECT DAMAGE, DAMAGE CAUSED BY IMPROPER INSTALLATION, OPERATION OR CARE (INCLUDING, BUT NOT LIMITED TO ABUSE, MISUSE, FAILURE TO PROVIDE REASONABLE AND NECESSARY MAINTENANCE, UNAUTHORIZED REPAIRS OR ANY ALTERATIONS TO THIS PRODUCT), LABOR CHARGES FOR REINSTALLING A REPAIRED OR REPLACED UNIT, REPLACEMENT OF BATTERIES AND LIGHT BULBS OR UNITS INSTALLED FOR NON-RESIDENTIAL USE.

THIS LIMITED WARRANTY DOES NOT COVER ANY PROBLEMS WITH, OR RELATING TO, THE GARAGE DOOR OR GARAGE DOOR HARDWARE, INCLUDING BUT NOT LIMITED TO THE DOOR SPRINGS, DOOR ROLLERS, DOOR ALIGNMENT OR HINGES. THIS LIMITED WARRANTY ALSO DOES NOT COVER ANY PROBLEMS CAUSED BY INTERFERENCE. ANY SERVICE CALL THAT DETERMINES THE PROBLEM HAS BEEN CAUSED BY ANY OF THESE ITEMS COULD RESULT IN A FEE TO YOU.

UNDER NO CIRCUMSTANCES SHALL SELLER BE LIABLE FOR CONSEQUENTIAL, INCIDENTAL OR SPECIAL DAMAGES ARISING IN CONNECTION WITH USE, OR INABILITY TO USE, THIS PRODUCT. IN NO EVENT SHALL SELLER'S LIABILITY FOR BREACH OF WARRANTY, BREACH OF CONTRACT, NEGLIGENCE OR STRICT LIABILITY EXCEED THE COST OF THE PRODUCT COVERED HEREBY. NO PERSON IS AUTHORIZED TO ASSUME FOR US ANY OTHER LIABILITY IN CONNECTION WITH THE SALE OF THIS PRODUCT.

Some States do not allow the exclusion or limitation of consequential, incidental or special damages, so the above limitation or exclusion may not apply to you. This limited warranty gives you specific legal rights, and you may also have other rights which vary from state to state.

Free Manuals Download Website

<http://myh66.com>

<http://usermanuals.us>

<http://www.somanuals.com>

<http://www.4manuals.cc>

<http://www.manual-lib.com>

<http://www.404manual.com>

<http://www.luxmanual.com>

<http://aubethermostatmanual.com>

Golf course search by state

<http://golfingnear.com>

Email search by domain

<http://emailbydomain.com>

Auto manuals search

<http://auto.somanuals.com>

TV manuals search

<http://tv.somanuals.com>