



Cisco XR 12404 Router Installation Guide

Americas Headquarters

Cisco Systems, Inc.
170 West Tasman Drive
San Jose, CA 95134-1706
USA
<http://www.cisco.com>
Tel: 408 526-4000
800 553-NETS (6387)
Fax: 408 527-0883

Text Part Number: OL-13830-02

THE SPECIFICATIONS AND INFORMATION REGARDING THE PRODUCTS IN THIS MANUAL ARE SUBJECT TO CHANGE WITHOUT NOTICE. ALL STATEMENTS, INFORMATION, AND RECOMMENDATIONS IN THIS MANUAL ARE BELIEVED TO BE ACCURATE BUT ARE PRESENTED WITHOUT WARRANTY OF ANY KIND, EXPRESS OR IMPLIED. USERS MUST TAKE FULL RESPONSIBILITY FOR THEIR APPLICATION OF ANY PRODUCTS.

THE SOFTWARE LICENSE AND LIMITED WARRANTY FOR THE ACCOMPANYING PRODUCT ARE SET FORTH IN THE INFORMATION PACKET THAT SHIPPED WITH THE PRODUCT AND ARE INCORPORATED HEREIN BY THIS REFERENCE. IF YOU ARE UNABLE TO LOCATE THE SOFTWARE LICENSE OR LIMITED WARRANTY, CONTACT YOUR CISCO REPRESENTATIVE FOR A COPY.

The following information is for FCC compliance of Class A devices: This equipment has been tested and found to comply with the limits for a Class A digital device, pursuant to part 15 of the FCC rules. These limits are designed to provide reasonable protection against harmful interference when the equipment is operated in a commercial environment. This equipment generates, uses, and can radiate radio-frequency energy and, if not installed and used in accordance with the instruction manual, may cause harmful interference to radio communications. Operation of this equipment in a residential area is likely to cause harmful interference, in which case users will be required to correct the interference at their own expense.

The following information is for FCC compliance of Class B devices: The equipment described in this manual generates and may radiate radio-frequency energy. If it is not installed in accordance with Cisco's installation instructions, it may cause interference with radio and television reception. This equipment has been tested and found to comply with the limits for a Class B digital device in accordance with the specifications in part 15 of the FCC rules. These specifications are designed to provide reasonable protection against such interference in a residential installation. However, there is no guarantee that interference will not occur in a particular installation.

Modifying the equipment without Cisco's written authorization may result in the equipment no longer complying with FCC requirements for Class A or Class B digital devices. In that event, your right to use the equipment may be limited by FCC regulations, and you may be required to correct any interference to radio or television communications at your own expense.

You can determine whether your equipment is causing interference by turning it off. If the interference stops, it was probably caused by the Cisco equipment or one of its peripheral devices. If the equipment causes interference to radio or television reception, try to correct the interference by using one or more of the following measures:

- Turn the television or radio antenna until the interference stops.
- Move the equipment to one side or the other of the television or radio.
- Move the equipment farther away from the television or radio.
- Plug the equipment into an outlet that is on a different circuit from the television or radio. (That is, make certain the equipment and the television or radio are on circuits controlled by different circuit breakers or fuses.)

Modifications to this product not authorized by Cisco Systems, Inc. could void the FCC approval and negate your authority to operate the product.

The Cisco implementation of TCP header compression is an adaptation of a program developed by the University of California, Berkeley (UCB) as part of UCB's public domain version of the UNIX operating system. All rights reserved. Copyright © 1981, Regents of the University of California.

NOTWITHSTANDING ANY OTHER WARRANTY HEREIN, ALL DOCUMENT FILES AND SOFTWARE OF THESE SUPPLIERS ARE PROVIDED "AS IS" WITH ALL FAULTS. CISCO AND THE ABOVE-NAMED SUPPLIERS DISCLAIM ALL WARRANTIES, EXPRESSED OR IMPLIED, INCLUDING, WITHOUT LIMITATION, THOSE OF MERCHANTABILITY, FITNESS FOR A PARTICULAR PURPOSE AND NONINFRINGEMENT OR ARISING FROM A COURSE OF DEALING, USAGE, OR TRADE PRACTICE.

IN NO EVENT SHALL CISCO OR ITS SUPPLIERS BE LIABLE FOR ANY INDIRECT, SPECIAL, CONSEQUENTIAL, OR INCIDENTAL DAMAGES, INCLUDING, WITHOUT LIMITATION, LOST PROFITS OR LOSS OR DAMAGE TO DATA ARISING OUT OF THE USE OR INABILITY TO USE THIS MANUAL, EVEN IF CISCO OR ITS SUPPLIERS HAVE BEEN ADVISED OF THE POSSIBILITY OF SUCH DAMAGES.

CCVP, the Cisco logo, and the Cisco Square Bridge logo are trademarks of Cisco Systems, Inc.; Changing the Way We Work, Live, Play, and Learn is a service mark of Cisco Systems, Inc.; and Access Registrar, Aironet, BPX, Catalyst, CCDA, CCDP, CCIE, CCIP, CCNA, CCNP, CCSP, Cisco, the Cisco Certified Internetwork Expert logo, Cisco IOS, Cisco Press, Cisco Systems, Cisco Systems Capital, the Cisco Systems logo, Cisco Unity, Enterprise/Solver, EtherChannel, EtherFast, EtherSwitch, Fast Step, Follow Me Browsing, FormShare, GigaDrive, HomeLink, Internet Quotient, IOS, iPhone, IP/TV, iQ Expertise, the iQ logo, iQ Net Readiness Scorecard, iQuick Study, LightStream, Linksys, MeetingPlace, MGX, Networking Academy, Network Registrar, *Packet*, PIX, ProConnect, ScriptShare, SMARTnet, StackWise, The Fastest Way to Increase Your Internet Quotient, and TransPath are registered trademarks of Cisco Systems, Inc. and/or its affiliates in the United States and certain other countries.

All other trademarks mentioned in this document or Website are the property of their respective owners. The use of the word partner does not imply a partnership relationship between Cisco and any other company. (0705R)

Any Internet Protocol (IP) addresses used in this document are not intended to be actual addresses. Any examples, command display output, and figures included in the document are shown for illustrative purposes only. Any use of actual IP addresses in illustrative content is unintentional and coincidental.

Cisco XR 12404 Router Installation Guide

© 2007 Cisco Systems, Inc. All rights reserved.



CONTENTS

About This Guide ix

Audience ix

Purpose ix

Installation Guide Organization x

Document Conventions xi

Obtaining Documentation, Obtaining Support, and Security Guidelines xii

CHAPTER 1

Cisco XR 12404 Router Overview 1-1

Router Overview 1-1

Physical and Functional Description of Router 1-2

Route Processor 1-3

Performance Route Processor Overview 1-5

PRP Memory Components 1-9

Supported Line Cards 1-13

Consolidated Switch Fabric Card 1-15

Alarm Functionality 1-15

Switch Fabric Functionality 1-17

Clock and Scheduler Functionality 1-17

Power Entry Modules 1-17

AC PEMs 1-18

DC PEMs 1-19

Power Distribution 1-20

Fan Tray Assembly 1-20

- Cable Management System **1-22**
- Maintenance Bus **1-24**
 - Power-On/Off Control **1-24**

CHAPTER 2**Preparing for Installation 2-1**

- Tools and Equipment **2-2**
- Safety and Compliance **2-2**
 - General Safety Guidelines **2-3**
 - Compliance and Safety Information **2-4**
 - Preventing Electrostatic Discharge Damage **2-4**
 - Laser Safety **2-6**
 - Lifting Guidelines **2-6**
- Safety with Electricity **2-8**
- Installation Site Requirements **2-8**
 - Rack-Mounting and Ventilation Guidelines **2-8**
 - Environmental Guidelines **2-11**
 - Power Connection Guidelines **2-13**
 - Site Wiring **2-15**
- Unpacking and Repacking the Cisco XR 12404 Router **2-16**
- Transporting a Cisco XR 12000 Series Router **2-17**
- Site Preparation Checklist **2-17**

CHAPTER 3**Installing the Router 3-1**

- Required Tools **3-2**
- Installing a Cisco XR 12404 Router **3-2**
 - Installing the Rack-Mounting Brackets—Optional **3-3**
 - Installing the Center-Mounting Brackets—Optional **3-5**
 - Installing the Chassis in a Rack **3-7**
 - Installing the Chassis on a Tabletop or Flat Surface **3-8**

Supplemental Bonding and Grounding Connections	3-8
Connecting RP and Line Card Cables	3-12
Connecting to the Console Port and Auxiliary Ports	3-14
PRP Console Port Signals	3-16
PRP Auxiliary Port Signals	3-17
Installing a Flash Memory Card	3-17
Connecting the PRP to an Ethernet Network	3-18
Connecting to an AC Power Source	3-23
Connecting to a DC Power Source	3-25
Powering on the Router for the First Time	3-28
External Network Interface	3-32
Manually Booting the System	3-32

CHAPTER 4**Troubleshooting the Installation 4-1**

Identifying Startup Problems	4-2
Using the System LEDs to Troubleshoot	4-3
Problem-Solving with Subsystems	4-5
Troubleshooting an AC Power Subsystem	4-6
Troubleshooting the DC Power Subsystem	4-9
Troubleshooting the Processor Subsystem	4-13
Troubleshooting the RP	4-14
Troubleshooting the Line Cards	4-19
Troubleshooting the Cooling Subsystem	4-19

CHAPTER 5**Maintaining the Router 5-1**

Tools and Equipment	5-2
Powering Off the Router	5-3
Removing and Installing the Front Cover	5-4

- Removing and Replacing the Air Filter **5-7**
- Removing and Replacing the Fan Tray Assembly **5-10**
 - Troubleshooting the Fan Tray Assembly Installation **5-12**
- Removing and Replacing an AC Power Entry Module **5-13**
 - Troubleshooting an AC PEM Installation **5-15**
- Removing and Replacing a DC Power Entry Module **5-17**
 - Troubleshooting the DC PEM Installation **5-20**
- Removing and Replacing a DC PDU **5-21**
 - Troubleshooting the DC PDU Installation **5-27**
- Removing and Replacing an RP or Line Card **5-29**
 - Attaching the Cable-Management Bracket and Connecting Cables **5-32**
- Removing and Replacing a Consolidated Switch Fabric Card **5-35**
- Upgrading the RP and Line Card Memory **5-37**

APPENDIX A**Technical Specifications A-1**

- Product Architecture **A-2**
 - Specifications **A-3**
- Compliance Information **A-5**
- Regulatory, Compliance, and Safety Information **A-8**
 - Translated Safety Warnings and Agency Approvals **A-8**
 - Electromagnetic Compatibility Regulatory Statements **A-8**

INDEX



About This Guide

Audience

The audience for the Cisco XR 12404 Router Installation Guide user documentation are the people who will install and configure a Cisco XR 12404 Router. The user typically has a substantial background in installing and configuring router- and switch-based Internets but may or may not have experience with Cisco products and supported protocols.

The reader of this documentation should be familiar with electronic circuitry and wiring practices and have experience as an electronic or electromechanical technician.

Purpose

This installation and configuration guide explains the hardware installation and basic configuration procedures for a Cisco XR 12404 Router. It contains procedures for installing the hardware, creating a basic configuration file, and starting up the router.

Installation Guide Organization

The Cisco XR 12404 Router Installation Guide has the following chapters and appendix; the paper version of this document may contain an index.

- Chapter 1, “Cisco XR 12404 Router Overview”—Contains a high-level system overview and physical description of the major components of a Cisco XR 12404 Router including the power and cooling systems, the power requirements, the Route Processor (RP) and the consolidated switch fabric (CSF) card which contains the clock and scheduler, alarm and switch fabric functions.
- Chapter 2, “Preparing for Installation”—Contains safety, site requirements for power, environmental safety, cabling, rack-mounting, electrostatic discharge (ESD), the site log, and site preparation checklist.
- Chapter 3, “Installing the Router”—Contains procedures for verifying the Cisco XR 12404 Router installation, grounding, cable connection, AC-and DC-power source and powering-up the router.
- Chapter 4, “Troubleshooting the Installation”—Contains procedures for identifying and solving problems that may occur during installation.
- Chapter 5, “Maintaining the Router”—Contains safety at the field replaceable unit (FRU) level, removal and replacement procedures for field-replaceable units, FRU assemblies, and associated procedures to troubleshoot and verify each FRU.
- Appendix A, “Technical Specifications”—Contains Cisco XR 12404 Router specifications.
- Index—Contains a keyword and subject index of pertinent terms and information.

Document Conventions

This publication uses the following conventions:

- The key combination **Ctrl-z** means hold down the **Control** key while you press the **z** key.

Command descriptions use these conventions:

- Examples that contain system prompts denote interactive sessions, indicating the commands that you should enter at the prompt. The system prompt indicates the current level of the EXEC command interpreter.

For example, the prompt `router>` indicates that you should be at the *user* level, and the prompt `router#` indicates that you should be at the *privileged* level. Access to the privileged level usually requires a password. Refer to the related software configuration and reference documentation for additional information.

- Commands and keywords are in **bold** font.
- Arguments for which you supply values are in *italic* font.
- Elements in square brackets ([]) are optional.
- Alternative but required keywords are grouped in braces ({ }) and separated by vertical bars (|).

Examples use these conventions:

- Terminal sessions and sample console screen displays are in *screen* font.
- Information you enter is in **boldface screen** font.
- Nonprinting characters, such as passwords, are in angle brackets (< >).
- Default responses to system prompts are in square brackets ([]).
- Exclamation points (!) at the beginning of a line indicate a comment line.



Caution

Means *reader be careful*. You are capable of doing something that might result in equipment damage or loss of data.



Note

Means *reader take note*. Notes contain helpful suggestions or references to materials not contained in this manual.

**Timesaver**

Means *the described action saves time*. You can save time by performing the action described in the paragraph.

**Warning**

This warning symbol means *danger*. You are in a situation that could cause bodily injury. Before you work on any equipment, be aware of the hazards involved with electrical circuitry and be familiar with standard practices for preventing accidents. To see translations of the warnings that appear in this publication, refer to the *Regulatory Compliance and Safety Information* document that accompanied this device.

Obtaining Documentation, Obtaining Support, and Security Guidelines

For information on obtaining documentation, obtaining support, providing documentation feedback, security guidelines, and recommended aliases and general Cisco documents, see the monthly *What's New in Cisco Product Documentation*, which also lists all new and revised Cisco technical documentation, at:

<http://www.cisco.com/en/US/docs/general/whatsnew/whatsnew.html>



CHAPTER 1

Cisco XR 12404 Router Overview

This chapter provides an overview of the Cisco XR 12404 router. It contains physical descriptions of the router hardware and major components, and functional descriptions of hardware-related features.

Router Overview

The Cisco XR 12404 router scales the Internet Service Provider edge from speeds of T3/E3 (44.7/34.4 Mbps) up to OC-192/STM-64 or 10GE (10 Gbps).

Figure 1-1 shows the PRP-2, consolidated switch fabric (CSF) card, and line card locations of the Cisco XR 12404 router. Network interfaces reside on the line cards that provide the connection between the router's CSF and the external networks. The bottom slot (labeled Fabric Alarm) is a dedicated slot for the combined CSF card.



Note

Illustration is shown without the front door for clarity.

Figure 1-1 Cisco XR 12404 Router—Front View

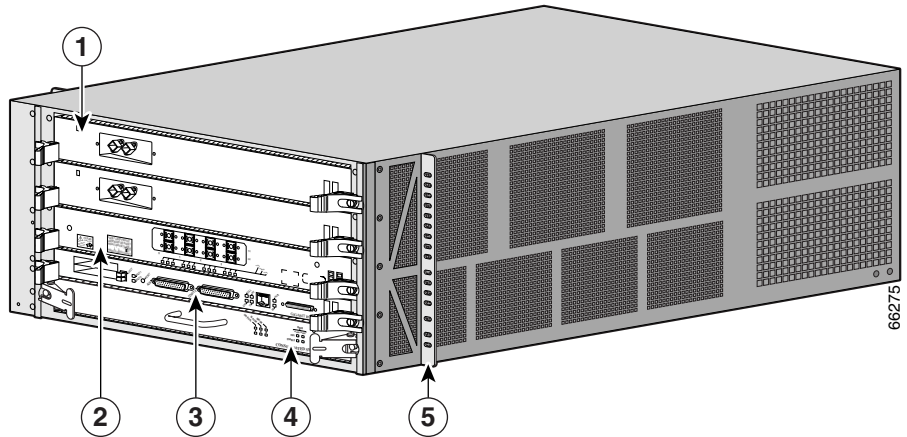

1	Line card	4	CSF card
2	Line card	5	Rack mounting bracket
3	Route Processor		

Physical and Functional Description of Router

The Cisco XR 12404 router supports up to 8 chassis in a one standard 7-foot (2.15 meter) rack and has the following key features:

- Route processor (PRP-2)—The primary route processor is installed in its own dedicated slot. A redundant route processor can go in any line card slot. See the “Route Processor” section on page 1-3 for information.
- Line cards—The card cage contains 4 hot-swappable card slots. The router can accommodate up to three OC-192 line cards (or 2 line cards if redundant route processors are installed). See the “Supported Line Cards” section on page 1-13 for information.
- Consolidated switch fabric card (CSF)—Switch fabric, alarm, and clock schedule functions are located on one board. The CSF card has a switching capacity of 10 Gbps. See the “Consolidated Switch Fabric Card” section on page 1-15 for information.

- AC power entry module (PEM)—A customized and hot-swappable one-piece unit. See the “Power Entry Modules” section on page 1-17 for information.
- DC power entry module (PEM) and DC power distribution unit (PDU)—Two pieces that can be removed as one unit or in separate pieces. See the “Power Entry Modules” section on page 1-17 for information.



Note When operating the router, both power module bays must have DC PEMs and DC PDUs installed to ensure EMI compliance.

- Fan tray assembly—Supplies cooling air to the router. See the “Fan Tray Assembly” section on page 1-20 for information.
- Cable management bracket used to neatly route line card cables. See the “Cable Management System” section on page 1-22 for information.
- Maintenance Bus—Controls all of the MBus modules in the system. See the “Maintenance Bus” section on page 1-24 for information.

Route Processor

The route processor for the Cisco XR 12404 router is the Performance Route Processor (PRP-2). For detailed information about the PRP-2, refer to the Cisco document, *Performance Route Processor Installation and Configuration Guide*.

The PRP-2 performs the following primary functions:

- Executes routing protocol stacks
- Performs all protocol communications with other routers
- Builds and distributes forwarding information to all line cards
- Uploads the operating system software images to all installed line cards during power-on
- Provides out-of-band system console and auxiliary ports and an Ethernet port for router configuration and maintenance
- Monitors and manages the power and temperature of system components such as line cards, power supplies, and fans

The Cisco PRP-2 delivers all these functions with enhanced performance and capabilities. It also delivers the following feature enhancements (depending on the software version running):

- 2 Ethernet management ports
- Hard-drive support (optional part)
- BITS input ports
- 1 GB compact image Flash memory support (optional part)
- Memory scalability up to 4 GB

The PRP-2 communicates with the line cards either through the switch fabric or through the MBus. The switch fabric connection is the main data path for routing table distribution as well as for packets that are sent between the line cards and the PRP-2. The MBus connection allows the PRP-2 to download a system bootstrap image, collect or load diagnostic information, and perform general, internal system maintenance operations.

The PRP-2 can be designated as either the Designated System Controller (DSC) or the Secure Domain router (SDR).

The Designated System Controller (DSC) performs the following functions:

- Implements control plane operations for the chassis
- Monitors temperature and voltage
- Monitors line cards
- On boot up, the first card to become active is designated as the DSC.

The Secure Domain Router (SDR) controls domain security features independent of any other SDRs on the network.

Performance Route Processor Overview

The performance route processor (PRP) uses a Motorola PowerPC 7450 CPU that runs at an external bus clock speed of 133 MHz and has an internal clock speed of 667 MHz.

Figure 1-2 identifies the slots, ports, and LEDs on the PRP front panel.

Figure 1-2 Performance Route Processor Front Panel

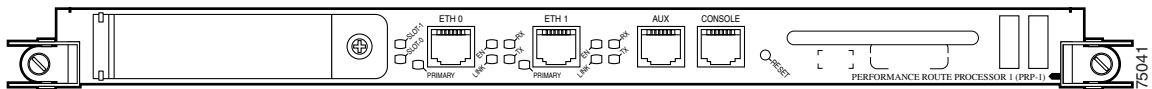

1	PCMCIA flash disk slots (shown with cover in place) and slot LEDs	4	Console serial port
2	RJ-45 Ethernet ports and data status LEDs	5	Reset button
3	Auxiliary serial port	6	Alphanumeric messages

PRP PCMCIA Card Slots and Status LEDs

Two PCMCIA card slots (slot 0 and slot 1) provide the PRP with additional flash memory capacity. All combinations of different flash devices are supported by the PRP. You can use ATA flash disks, Type 1 or Type 2 linear flash memory cards, or a combination of the two.



Note

The PRP only supports +5.2 VDC flash memory devices. It does *not* support +3.3 VDC PCMCIA devices.

Status LEDs (Slot-0 / Slot-1) indicate when the flash memory card in that slot is accessed (see Figure 1-2). Each slot has an eject button (located behind the cover) to remove a flash card from the slot.

PRP Ethernet Ports and Status LEDs

The PRP has two 8-pin media-dependent interface (MDI) RJ-45 ports for either IEEE 802.3 10BASE-T (10 Mbps) or IEEE 802.3u 100BASE-TX (100 Mbps) Ethernet connections. These ports are labeled ETH 0 and ETH 1.

The transmission speed of the Ethernet port is not user-configurable. You set the speed through an autosensing scheme on the PRP which is determined by the network that the Ethernet port is connected to. However, even at an autosensed data transmission rate of 100 Mbps, the Ethernet port can only provide a usable bandwidth of substantially less than 100 Mbps. You can expect a maximum usable bandwidth of approximately 20 Mbps when using an Ethernet connection.

The following LEDs on the front panel indicate traffic status and port selection (Figure 1-3):

- LINK, EN, TX, RX—Indicate link activity (LINK), port enabled (EN), data transmission (TX), and data reception (RX).
- PRIMARY—Indicates which Ethernet port is selected (ETH 0 or ETH 1).



Note Because both ports are supported on the PRP, ETH 0 is always on. ETH 1 lights when it is selected.

Figure 1-3 Port Activity LEDs—Partial Front Panel

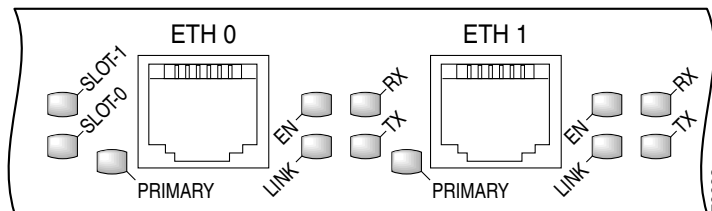

PRP Auxiliary and Console Ports

The auxiliary and console ports on the PRP are EIA/TIA-232 (also known as RS-232) asynchronous serial ports. These ports connect external devices to monitor and manage the system.

- The auxiliary port—A (male) plug that provides a data terminal equipment (DTE) interface. The auxiliary port supports flow control and is often used to connect a modem, a channel service unit (CSU), or other optional equipment for Telnet management.
- The console port—A (female) receptacle that provides a data circuit-terminating equipment (DCE) interface for connecting a console terminal.

PRP Reset Switch

Access to the (soft) reset switch is through a small opening in the PRP front panel (see Figure 1-2). To press the switch, insert a paper clip or similar small pointed object into the opening.



Caution

The reset switch is *not* a mechanism for resetting the PRP and reloading the Cisco IOS image. It is intended for software development use only. To prevent system problems or loss of data, use the reset switch only on the advice of Cisco service personnel.

Pressing the reset switch causes a nonmaskable interrupt (NMI) and places the PRP in ROM monitor mode. When the PRP enters ROM monitor mode, its behavior depends on the setting of the PRP software configuration register. For example, if the boot field of the software configuration register is set to:

- 0x0—The PRP remains at the ROM monitor prompt (rommon>) and waits for a user command to boot the system manually.
- 0x1—The system automatically boots the first Cisco IOS image found in flash memory on the PRP.

PRP Alphanumeric Message Displays

The alphanumeric message displays are organized in two rows of four LED characters each (Figure 1-4).

Figure 1-4 Alphanumeric Message Displays—Partial Front Panel

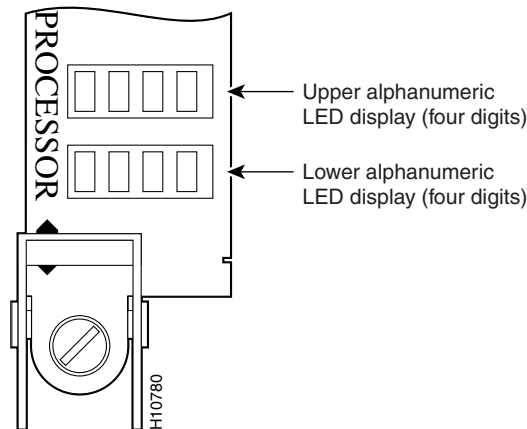

The alphanumeric message displays show router status messages during the boot process, and after the boot process is complete.

- During the boot process, the message displays are controlled directly by the MBus module.
- After the boot process, the message displays are controlled by Cisco IOS XR software (through the MBus).

The alphanumeric message displays also provide information about different levels of system operation, including the status of the PRP, router error messages, and user-defined status and error messages



Note

A list of all system and error messages appears in the *Cisco IOS System Error Messages* publication.

PRP Memory Components

This section describes various types of memory used on the PRP to support router functions. Table 1-1 provides a quick reference of the different types of memory, and Figure 1-5 shows the location on the PRP board.

Table 1-1 PRP Memory Components

Type	Size	Quantity	Description	Location
SDRAM	512 MB ¹ , 1 GB, or 2 GB	1 or 2	Uses 512 MB or 1 GB DIMMs (based on SDRAM configuration) for main Cisco IOS XR software functions	U15 (bank 1) U18 (bank 2)
SRAM	2 MB (fixed)	—	Secondary CPU cache memory functions	—
NVRAM	2 MB (fixed)	—	System configuration files, register settings, and logs	—
Flash memory	64 MB SIMM	1	Cisco IOS XR boot image (bootflash), crash information, and other user-defined files	P3
Flash disk (PCMCIA)	64 MB ¹	1 or 2	Cisco IOS XR software images, system configuration files, and other user-defined files on one or two Flash memory cards	Flash memory card slot 0 and slot 1
Flash boot ROM	512 KB	1	Flash EPROM for the ROM monitor program boot image	—

1. Default shipping configuration.

Figure 1-5 PRP Memory Locations

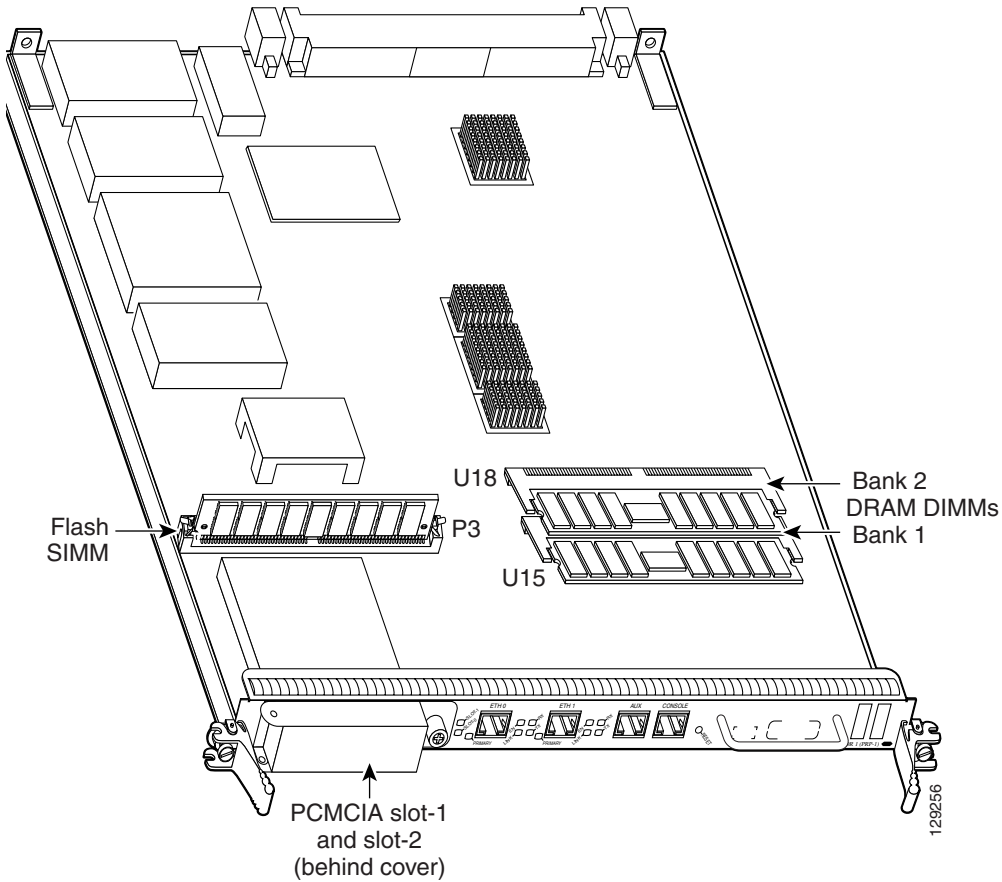

PRP SDRAM

The PRP uses Error Checking and Correction (ECC) Synchronized Dynamic Random Access Memory (SDRAM) to store routing tables, protocols, network accounting applications, and to run Cisco IOS software.

Table 1-2 lists the DRAM configurations for the PRP. If you are using:

- One DIMM—Bank 1 (U15) must be populated first.
- Two DIMMs—You cannot mix memory sizes; both banks must contain the same size DIMM.

Table 1-2 *PRP DRAM Configurations*

Total SDRAM	SDRAM Sockets	Number of DIMMs
512 MB ¹	U15 (bank 1) U18 (bank 2)	One 512 MB DIMM or Two 256 MB DIMMs
1 GB	U15 (bank 1) U18 (bank 2)	One 1 GB DIMM or Two 512 MB DIMMs
2 GB	U15 (bank 1) U18 (bank 2)	Two 1 GB DIMMs

1. Default shipping configuration.



Caution

DRAM DIMMs must be 3.3-volt, 60-nanosecond devices only. Do not attempt to install other devices in the DIMM sockets. To prevent memory problems, use the Cisco approved memory products listed in Table 1-2.

PRP SRAM

Static Random Access Memory (SRAM) provides 2 MB of secondary CPU cache memory. Its principal function is to act as a staging area for routing table updates, and for information sent to and received from the line cards. SRAM is *not* user-configurable and cannot be upgraded in the field.

PRP NVRAM

Non-volatile Random Access Memory (NVRAM) provides 2 MB of memory for system configuration files, software register settings, and environmental monitoring logs. Built-in lithium batteries retain the contents of NVRAM for a minimum of 5 years. NVRAM is *not* user configurable and cannot be upgraded in the field.

PRP Flash Memory

Use flash memory to store multiple Cisco IOS XR software and microcode images that you can use to operate the router. You can download new images to flash memory over the network (or from a local server) to replace an existing image, or to add it as an additional image. The router can be booted (manually or automatically) from any of the stored images in flash memory.

Flash memory also functions as a Trivial File Transfer Protocol (TFTP) server to allow other servers to boot remotely from the stored images, or to copy them into their own flash memory.

The system uses two types of flash memory:

- Onboard flash memory (called *bootflash*)—Contains the Cisco IOS boot image
- Flash memory disks (or cards)—Contain the Cisco IOS software image

Table 1-3 lists supported flash disk sizes and Cisco part numbers.

Table 1-3 Supported Flash Disk Sizes

Flash Disk Size ¹	Part Number
64 MB ²	MEM-12KRP-FD64=
128 MB	MEM-12KRP-FD128=
1 GB	MEM-12KRP-FD1G=

1. Standard Type 1 and Type 2 linear flash memory cards also are supported, although they may not have the capacity to meet the configuration requirements of your system.
2. Default shipping configuration.

Supported Line Cards

The Cisco XR 12404 router is shipped with up to three installed line cards and one route processor that provide a variety of network media types. Line card slots and route processors shipped from the factory are based on your order. Figure 1-6 shows the card cage slot locations:

- Line cards can be installed in slots 1 through 3 in the card cage.
- Slot zero (0) is the default slot for the primary route processor.
- The bottom slot is reserved for the consolidated switch fabric (CSF) card.

**Note**

Refer to the software release notes for a current list of supported line cards (see the “Obtaining Documentation, Obtaining Support, and Security Guidelines” section on page -xii).

Figure 1-6 Card Slot Locations

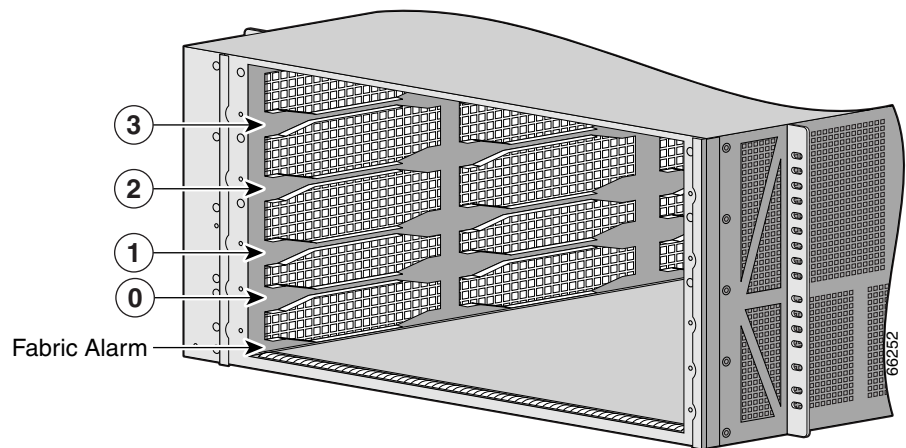

The line cards interface to each other, and to the route processor through the CSF card. Line cards installed in the Cisco XR 12404 router are hot swappable and can be replaced while the router is operating.

Figure 1-7 shows examples of single-mode and multimode line cards.

Figure 1-7 Sample Line Cards

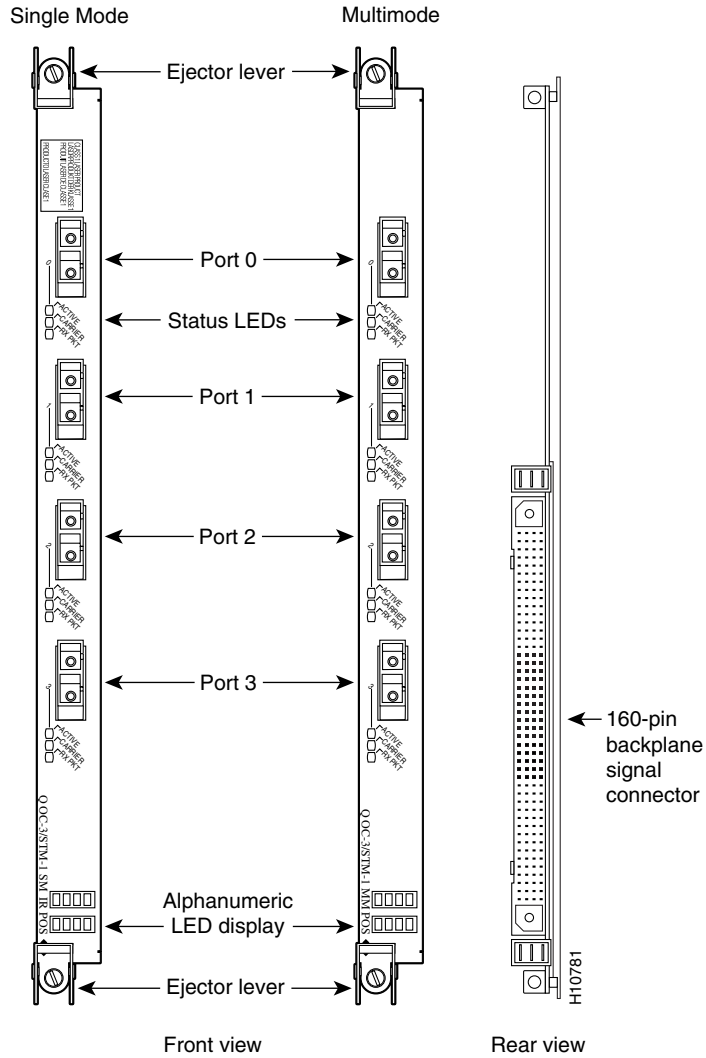

Consolidated Switch Fabric Card

The Cisco XR 12404 router CSF card contains the following functionality:

- Alarm notification and power source monitoring
- Switch fabric synchronized speed interconnections
- Clock and scheduler synchronization signaling

Alarm Functionality

The CSF card alarm functionality provides visual alarm notification of a fault condition. The alarm card function indicates the following condition.

- Alarm status
- CSF MBus
- Alarm MBus status
- Fan fault monitoring
- AC or DC power source status
- DC PEM status
 - The 5V MBus power supply has been integrated onto the CSF permitting the use of generic PEMs in the chassis. The Cisco XR 12404 router can monitor for the PEM for these conditions:
- The operational status
- Output voltage
- Output current.
- Alarm Output Function
 - The alarm output function is controlled by the software on the route processor. When a signal is received from the route processor the alarm MBus module on the CSF card activates specific LEDs to signal a condition that is critical, major, or minor.

- LEDs
 - LEDs alert you to a condition in the router. The determination of a critical, major, or minor alarm condition is designed into Cisco IOS XR software running on your route processor.
- CSF MBus Status
 - Drivers are provided for MBus OK and Fail indication.
- The 5V MBus power supply
 - Consists of a 100 W DC-DC converter.
- Alarm Status
 - The Alarm output function consists of a group of LEDs and their associated drivers connected to an output port on the alarm MBus module. As directed by the software on the route processor, the alarm MBus module on the CSF card activates specific LEDs. The software which drives these LEDs divides them into three levels, Critical, Major, and Minor. The classification of a critical, major, or minor alarm is determined by Cisco IOS XR software running on the route processor. Each of the three LEDs is a dual LED (for failure redundancy).
 - The OK/Fail pair of LEDs indicate the status of the alarm MBus:
Green indicates that the alarm MBus module is operating properly.
Amber Fail indicates that the alarm MBus has detected an error in itself or with the MBus module.

Power Source Monitoring

The alarm MBus monitors the power supply and signals when there is a condition outside the normal range of operation.

- Power source voltage is not being provided to a component
- A fault exist in the power source or PEM
- A voltage monitor signal is outside the allowable range
- The current monitor signal is outside the allowable range

Switch Fabric Functionality

Switch fabric circuitry provides up to 40 Gbps (full duplex) of synchronized speed interconnections that carries user traffic between line cards or between the route processor and the line cards.

Clock and Scheduler Functionality

The fabric card generates and distributes system-wide clock and cell time synchronization signaling. System clock generation is delivered to the system through the backplane and local clock functions are derived from the system clock.

- **System Clock**—The system clock synchronizes data transfers between line cards or between the route processor and a line card through the CSF. The system clock signal is sent to all line cards and the route processor.
- **Scheduler**—The scheduler handles requests from the line cards for access to the CSF. When the scheduler receives a request from a line card for CSF access, the scheduler determines when to allow the line card access to the CSF.

Power Entry Modules

The Cisco XR 12404 router chassis supports two hot swappable AC or DC PEMs. The router must be populated with 2 PEMs to meet EMI standards.



Caution

Do not mix PEM types in the router. PEMs must be the same type; either both AC PEMs, or both DC PEMs and PDUs.

AC PEMs

Each AC PEM converts 200 to 240 VAC into -48 VDC, which is distributed through the chassis backplane to all cards, RPs, and the fan assembly.

Figure 1-8 identifies the components of an AC power supply.

Figure 1-8 AC PEM Components

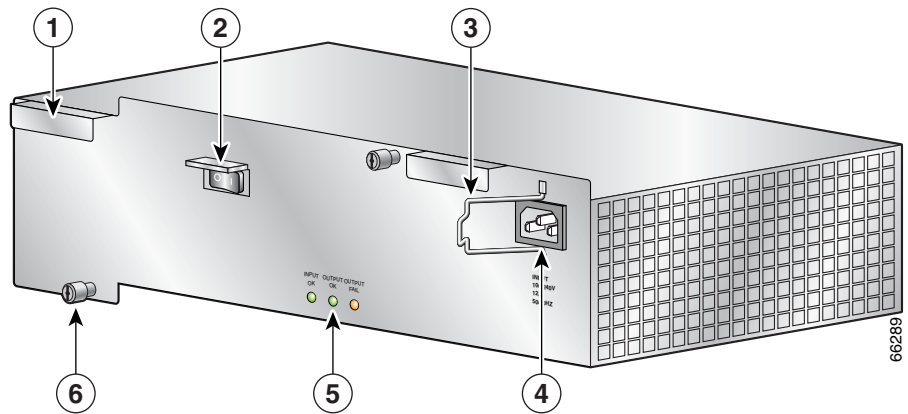

1	AC PEM finger grips	4	Power cord receptacle
2	On/Off switch	5	Status LEDs
3	Bail latch	6	Captive screws

The status LEDs on the AC PEM provide information about the current operational status of the power supply. Table 1-4 summarizes the function of these indicators.

Table 1-4 AC-Input PEM LED Indicators

LED Label	Color	Function
OUTPUT OK	Green	PEM is powered on and operating normally.

Table 1-4 AC-Input PEM LED Indicators (continued)

LED Label	Color	Function
Input OK	Green	The AC power source is present and operating within the specified limit.
Output Fail	Amber	Indicates a failure in the PEM.

DC PEMs

Each DC PEM operates from a nominal source DC voltage of -48 to -60 VDC and requires a dedicated 60 amp service.

Figure 1-9 identifies the components of a DC power supply.

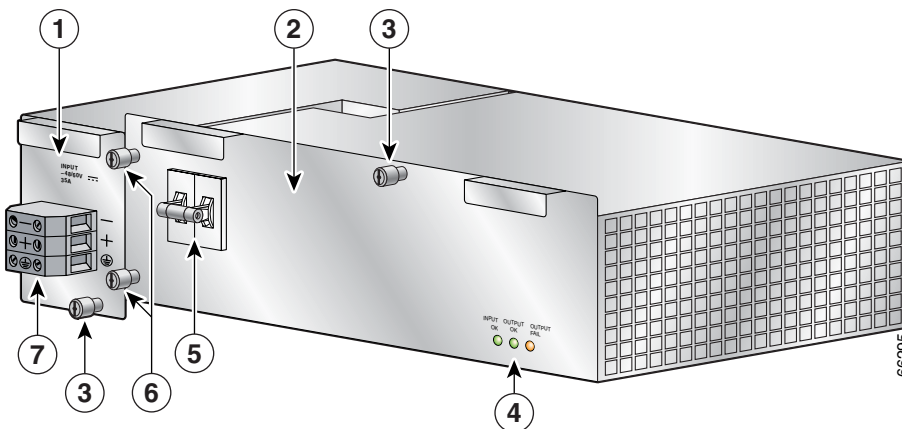
Figure 1-9 DC PEM and PDU Components

1	DC PDU	5	On/Off switch
2	DC PEM	6	PDU captive screws
3	PEM captive screws	7	PDU terminal block
4	Status LEDs		

The status LEDs on the DC PEM provide information about the current operational status of the power supply. Table 1-5 summarizes the function of these indicators.

Table 1-5 DC-Input PEM LED Indicators

LED Label	Color	Function
Output OK	Green	PEM is powered on and operating normally.
Input OK	Green	DC power is present at the PEM input and within the specified limits.
Output Fail	Amber	Indicates a failure in the PEM.

Power Distribution

The backplane distributes power through the Cisco XR 12404 router and to all cards in the card cage. The PEM converts AC power source into –48 VDC. When directed by the route processor or by MBus software, the MBus module turns on the DC-DC converter; the –48 VDC is converted into +2.5 VDC, +3.3 VDC and +5 VDC for all internal voltages required by the cards.

Power for the fan tray assembly is supplied directly from the backplane. An internal fan tray assembly controller card converts –48 VDC into DC voltage that powers the fans.

Fan Tray Assembly

The Cisco XR 12404 router is equipped with a fan tray assembly located at the side of the chassis. The fan tray assembly maintains acceptable operating temperatures for the internal components by drawing cooling air across the card cage.

The fan tray assembly is a sheet metal enclosure containing 7 fans and 2 fan controller cards (Figure 1-10).

**Warning**

Exhaust from other equipment vented directly into the Cisco XR 12404 router air inlet can cause an over-heat condition. Install the router so that it is protected from a direct flow of hot air from other equipment.

Figure 1-10 Fan Tray Assembly

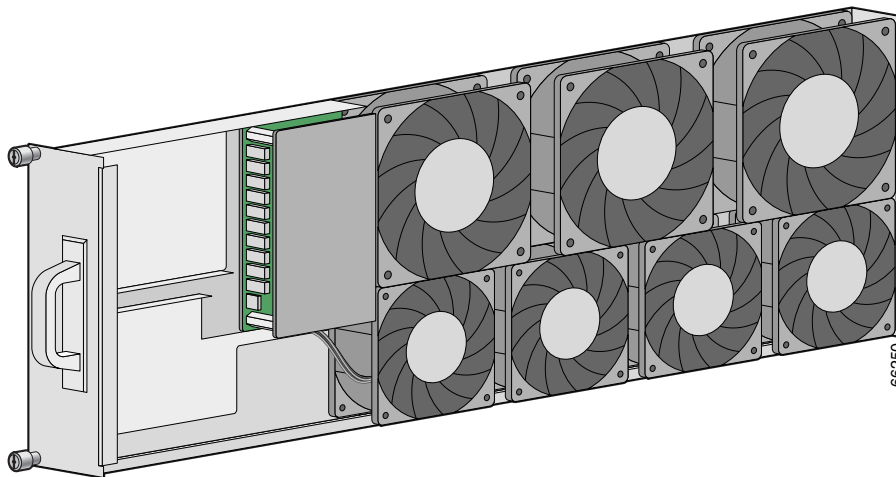

The fan tray assembly draws room air in through the air filter, across the card cage and out through exhaust vents located on the side of the chassis.

**Note**

Warm air exits at the side of the chassis. Allow sufficient air flow by maintaining 6 inches (15.24 CM) of clearance at both the inlet and exhaust openings on the chassis.

A fan tray assembly controller card monitors the operation of the 7 fans.

Cable Management System

The Cisco XR 12404 router is set up with two types of cable management systems:

- Line card cable-management bracket (Figure 1-11)—Attached to each line card and routes the line card cables to the chassis cable management bracket. These brackets keep the cables free of sharp bends and out of the way.

Figure 1-11 RP and Line Card Cable-Management Brackets

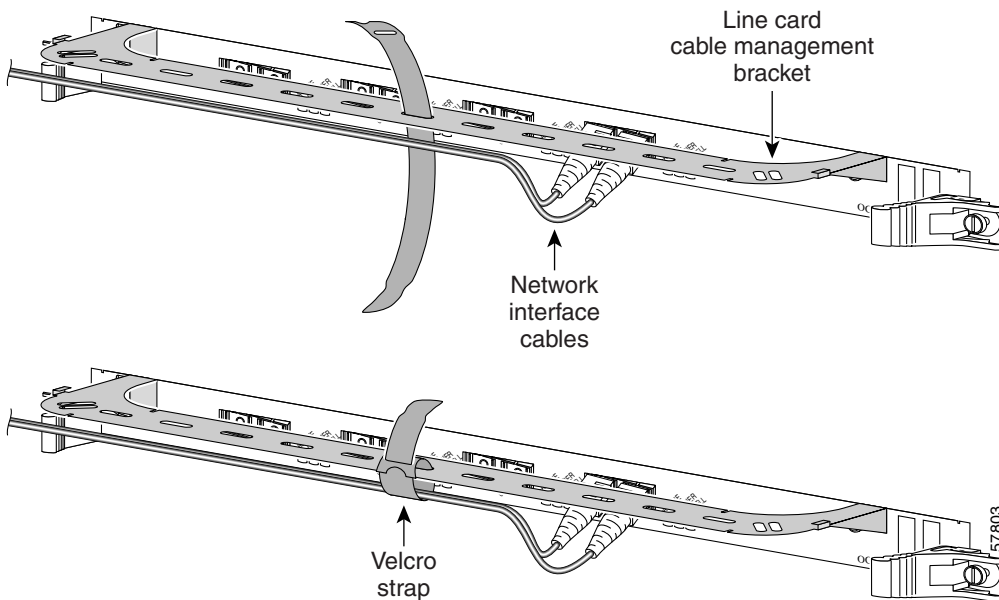

- Chassis cable-management bracket (see Figure 1-12)—Attached to the chassis and routes the line card cables away from the chassis.

Figure 1-12 Chassis Cable Management Bracket

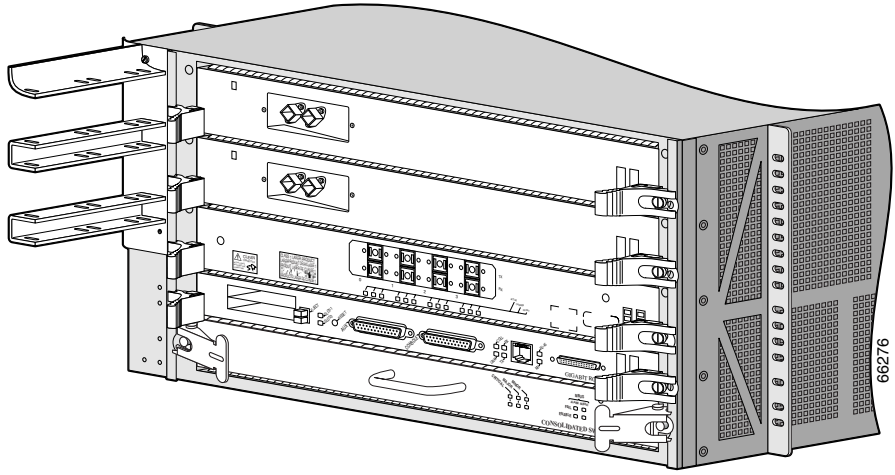

Cable-management systems:

- Organize the interface cables on the line cards, route processor, and clock and scheduler cards as they enter and exit the system.
- Consists of two parts, a card cable-management bracket and a chassis cable-management bracket.



Caution

Excessive bending in an interface cable can cause performance degradation.

Maintenance Bus

The Cisco XR 12404 router maintenance bus and MBus modules manage all of the maintenance functions of the system. The MBus consists of two separate busses (providing MBus redundancy). Each MBus is linked to all of the following.

- Line cards
- Route Processor
- CSF card

The MBus module located on each component, communicates over the MBus and is powered by +5 VDC directly from the fabric card. The MBus performs the functions of power-on/off control for each component, component (device) discovery, code download, diagnostics, and environmental monitoring and alarms.

Power-On/Off Control

Each MBus module directly controls the DC-to-DC converters on the component it is mounted on based on commands the component receives from its on-board EPROM and from the route processor. Each MBus module is tied directly to +5 VDC from the consolidated fabric card.

When power is applied to the Cisco XR 12404 router, all MBus modules immediately power on. The MBus modules on the route processor and CSF card immediately turn on the DC-to-DC converter, powering up the respective card. The line card MBus module waits to power on the line card until it receives a command from the route processor.

Component Discovery

The route processor can determine the system configuration using the MBus. A message is sent from the route processor over the MBus requesting all installed devices to identify themselves. The response back provides component type, line card slot number, and CSF card slot number.

Code Download

A portion of the line card operating software can be downloaded from the route processor to the line card over the MBus. Because the MBus is relatively slow compared to the CSF, only enough code is downloaded to the line card for it to access the CSF and complete the download process.

Diagnostics

The diagnostic software image is downloaded from the route processor to the line card during the test sequence.

Environmental Monitoring and Alarms

The MBus module on each component monitors that component's environment as follows.

- Line cards and the route processor are monitored for temperature by two temperature sensors mounted on each card. The MBus module makes voltage monitoring through software; for example the +2.5 VDC, +3.3 VDC, and +5 VDC DC-to-DC converters.
- The CSF card is monitored for temperature by two temperature sensors mounted on the card. The MBus module performs voltage monitoring through software (for example, the +2.5 VDC and +3.3 VDC).
- Voltage monitoring for +5 VDC, for example; is made by the alarm MBus module on the CSF card.
- Environmental monitoring includes voltage and current monitoring, temperature monitoring, and sensing for fan power and RPM.



CHAPTER 2

Preparing for Installation

This chapter provides specific information about preparing your site for the installation of the Cisco XR 12404 Router. Included in this chapter are:

- Tools and Equipment, page 2-2
- Safety and Compliance, page 2-2
- Safety with Electricity, page 2-8
- Installation Site Requirements, page 2-8
- Unpacking and Repacking the Cisco XR 12404 Router, page 2-16
- Transporting a Cisco XR 12000 Series Router, page 2-17
- Site Preparation Checklist, page 2-17

Before installing the Cisco XR 12404 Router, you should consider the following:

- Power and cabling requirements that must be in place at your installation site
- Equipment you will need to install the router
- Environmental conditions your installation site must meet to maintain normal operation.



Note Do not unpack the router until you are ready to install it.

Tools and Equipment

The Cisco XR 12404 Router is designed to be installed with a minimum number of tools. The following tools are required.

- 1/4-inch flat-blade screwdriver
- 3/16-inch flat-blade screwdriver
- 9/16-inch wrench
- 10-mm wrench (either open-end or socket)
- 2-mm allen wrench
- ESD-preventive wrist or ankle strap
- Antistatic mat
- Tape measure
- Wire cutters
- Pliers

Safety and Compliance

The following guidelines will help to ensure your safety and protect the equipment. This list is not inclusive of all potentially hazardous situations, so be alert.

- General Safety Guidelines, page 2-3
- Preventing Electrostatic Discharge Damage, page 2-4
- Laser Safety, page 2-6
- Laser Safety, page 2-6
- Lifting Guidelines, page 2-6

General Safety Guidelines

The following are some general safety guidelines you should be aware of when installing or maintaining the Cisco XR 12404 Router.

- Never attempt to lift an object that might be too heavy for you to lift by yourself.
- Always disconnect the power source and unplug all power cables before lifting, moving or working on the router.
- Keep the work area clear and dust free during and after installation.
- Keep tools and router components away from walk areas.
- Do not wear loose clothing, jewelry (including rings and chains), or other items that could get caught in the router.
- Fasten your tie or scarf and sleeves.
- Cisco equipment operates safely when it is used in accordance with its electrical ratings and product usage instructions.
- Do not work alone if potentially hazardous conditions exist.
- Always unplug the power cables when performing maintenance or working on the router, unless the replacement part is capable of online insertion and removal, hot swappable.
- The installation of the router should be in compliance with national and local electrical codes: in the United States, National Fire Protection Association (NFPA) 70, United States National Electrical Code; in Canada, Canadian Electrical Code, part I, CSA C22.1; in other countries, International Electrotechnical Commission (IEC) 364, part 1 through part 7.
- Before installing, configuring, or maintaining the router, review the safety warnings listed in the document *Regulatory Compliance and Safety Information for the Cisco XR 12000 Series Routers*.
- A Cisco XR 12404 Router configured with the AC power entry module (PEM) are shipped with a three-wire electrical grounding-type plug that will only fit into a grounding-type power outlet. This is a safety feature. The equipment grounding should be in accordance with local and national electrical codes.

- A Cisco XR 12404 Router configured with a DC PEM requires a dedicated 35–Amp DC circuit breaker for the DC power source. This circuit breaker should protect against short-circuit and overcurrent faults in accordance with United States National Electrical Code NFPA 70 (United States), Canadian Electrical Code, part I, CSA C22.1; CSA C22.2 No. 0 (Canada) and IEC 364 (other countries).
- Only a DC power source that complies with the safety extra-low voltage (SELV) requirements in UL60950, CSA 60950, EN60950, and IEC 60950 can be connected to a Cisco XR 12404 Router DC PEM.
- A Cisco XR 12404 Router configured with a DC PEM is to be installed in a restricted access area and in accordance with Articles 110–18, 110–26, and 110–27 of the National Electric Code, ANSI/NFPA 70.
- A Cisco XR 12404 Router configured with a DC power distribution unit (PDU) shall have a readily accessible disconnect device incorporated in the fixed wiring.

Compliance and Safety Information

The Cisco XR 12404 Router is designed to meet the regulatory compliance and safety approval requirements. Refer to the *Regulatory Compliance and Safety Information for the Cisco XR 12000 Series Routers*.

Preventing Electrostatic Discharge Damage

Electrostatic discharge (ESD) damage to circuit boards can occur if they are handled improperly. Such mishandling can result in intermittent or complete failures of the board.

When handling circuit boards, observe the following guidelines to prevent ESD damage.

- Always use an ESD-preventive ankle or wrist strap and ensure that the strap makes adequate contact with your skin.
- The ankle or wrist strap protects equipment from ESD voltages on the body only; ESD voltages on clothing can still cause damage to electronic components.

Attaching an ESD-Preventive Strap

Attach an ESD antistatic strap to your body and to an open metal part of the chassis on the Cisco XR 12404 Router (Figure 2-1).

Figure 2-1 Attaching an ESD-Preventive Strap to the Cisco XR 12404 Router Chassis

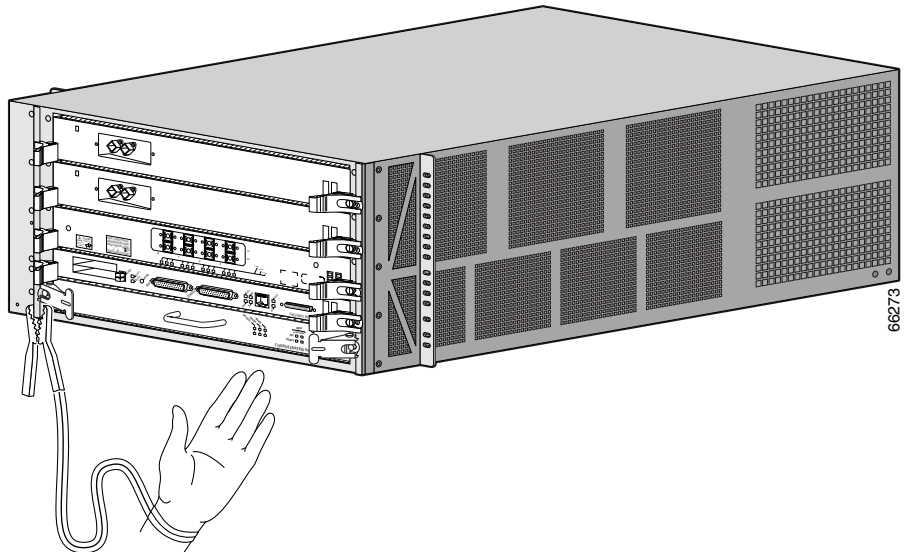
**Caution**

Periodically check the resistance value of the antistatic ankle or wrist strap. The resistance measurement should be between 1 and 10 megohms.

Laser Safety

Single-mode style line cards for the Cisco XR 12404 Router are equipped with lasers, which emit invisible radiation. Do not stare into open line card ports.



Warning

Avoid exposure to laser radiation. Do not stare into an open apertures, because invisible laser radiation may be emitted from the aperture when a cable is not inserted in the port.

Lifting Guidelines

A fully configured Cisco XR 12404 Router weighs approximately 100 pounds (45.36 kg). Before you install the router, ensure that your site is properly prepared so you can avoid having to move the router later to accommodate power source and network connections (Figure 2-2).

Figure 2-2 *Lifting a Cisco XR 12404 Router*

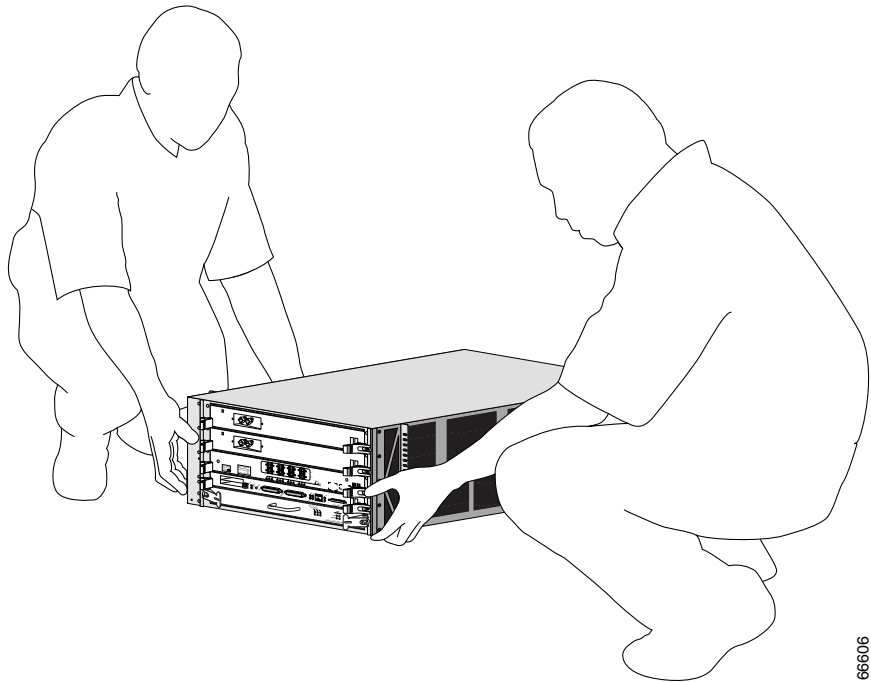

90606

Each time you lift any heavy assembly, refer to these lifting guidelines:

- Never attempt to lift an object that might be too heavy for you to lift by yourself
- Have a second person available to help lift the assembly
- Ensure that your footing is solid; balance the weight of the object between your feet
- Lift the assembly slowly; never move suddenly or twist your body as you lift
- Keep your back straight and lift with your legs, not your back
- If you must bend down to lift the assembly, bend at the knees, not at the waist, to reduce the strain on your lower back muscle
- Always disconnect the power source and unplug all power cables before lifting, moving or working on the router

Safety with Electricity

Most Cisco XR 12404 Router field replaceable units (FRUs) support online insertion and removal (OIR), which means an FRU is hot-swappable and can be removed and replaced while the system is operating without presenting an electrical hazard or damage to the system.

Installation Site Requirements

This section provides site requirement guidelines that you must consider before installing the Cisco XR 12404 Router.

Rack-Mounting and Ventilation Guidelines

Before installing the Cisco XR 12404 Router in a rack, consider the following general rack-mounting guidelines.

As you face the rear of the chassis, the fan tray assembly is located on the right side. Air flow to the air filter and fan tray assembly should not be blocked.

**Note**

Warm air exhaust at the side of the chassis through the fan tray. Allow sufficient air flow by maintaining 6 inches (15.24 CM) of clearance at both the inlet and openings on the chassis.

- A ventilation system that is too powerful in an enclosed rack can also prevent cooling by creating negative air pressure around the chassis and redirecting the air away from the air intake vent. If necessary, operate the router with the rack door open or in an open rack.
- The correct use of baffles inside an enclosed rack can assist in cooling the router.
- Equipment located near the bottom of the rack can generate excessive heat that is drawn upward and into the intake ports of equipment above, leading to possible overheat conditions.

Rack Mounting Clearance

The rack-mounting hardware included with the Cisco XR 12404 Router is suitable for most 19 inch equipment racks.

The following are rack-mounting guidelines for the Cisco XR 12404 Router.

- If you use a standard 19 inch racks be sure that the rack is bolted to the floor. The chassis mounts to the two rack posts, and the rest of the chassis is cantilevered off of the posts.
- Ensure that the weight of the Cisco XR 12404 Router does not make the rack unstable.
- Some racks are secured to ceiling brackets, if necessary, because of the weight of the equipment in the rack. Make sure that the rack you are installing the Cisco XR 12404 Router in is secured.
- For the enhanced model of the Cisco XR 12404 Router, the mounting rails on a 4-post rack must be recessed no more than 1.5 inches for the front door to fully open and close and to provide adequate room for cable routing.

Multiple Routers in a Rack

One of the unique features of the Cisco XR 12404 Router is its size. Up to 8 Cisco XR 12404 Routers can fit in a standard 19 inch equipment rack. When placing multiple routers in a rack, ensure there is sufficient ventilation to accommodate the router.

The heated exhaust air from other equipment can enter the inlet air vents and cause an overtemperature condition inside the router.

- Install and use the line card brackets and chassis cable-management bracket included with the router to keep cables organized and out of the way of line cards.
- Ensure that cables from other equipment do not interfere with access to the card cage, or require you to disconnect cables unnecessarily to perform equipment maintenance or upgrades.
- When mounting the router in a four-post type rack, be sure to use all of the screws provided to secure the chassis to the rack posts.

Figure 2-3 shows the outer dimensions of the Cisco XR 12404 Router chassis with the front door installed.

Figure 2-3 Cisco XR 12404 Router Chassis Outer Dimensions—Top View

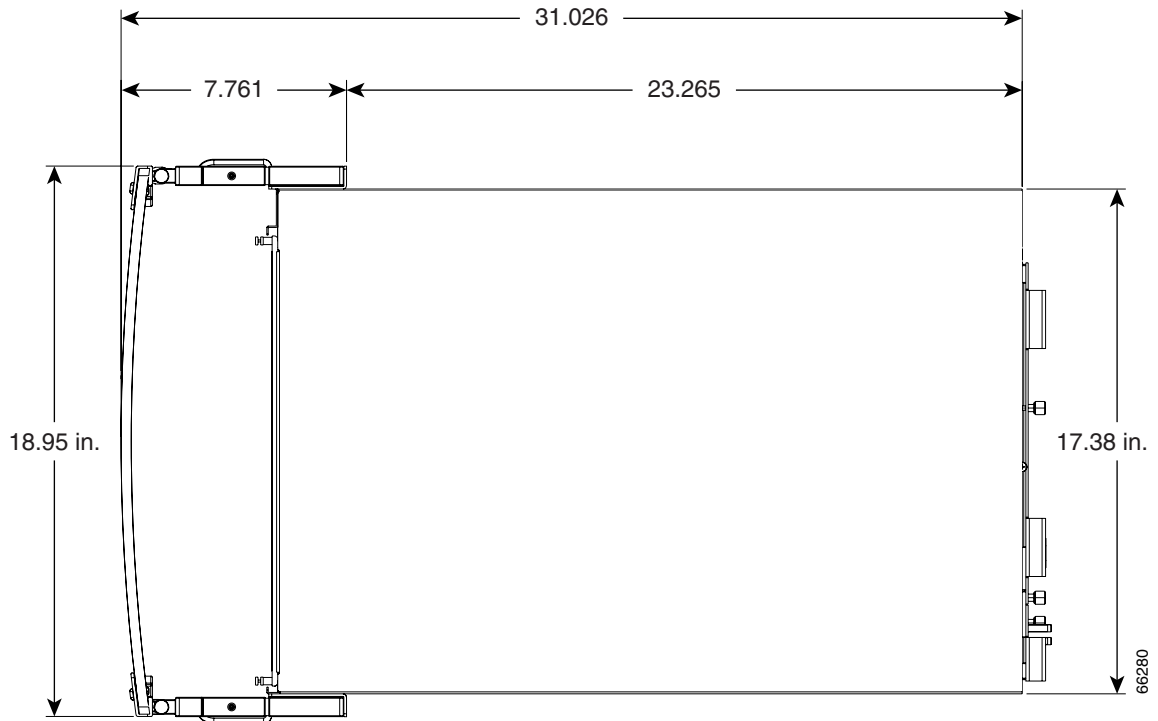

Environmental Guidelines

This section offers guidelines for operating your Cisco XR 12404 Router in various environments; airflow, temperature and humidity, power source, AC and DC powered routers, grounding connections and site wiring. To assure normal operation and avoid maintenance difficulty, plan and prepare your site before you install the router.

Airflow

The Cisco XR 12404 Router air circulation system consists of 1 fan tray assembly mounted at the side of the chassis. The fan tray assembly maintains acceptable operating temperatures for the internal components by drawing cooling air in through a replaceable air filter, located on the right side of the chassis.

Air circulates through the card cage, and exhausts at the side of the chassis (Figure 2-4).

- Allow sufficient air flow by maintaining 6 inches (15.24 cm) of clearance at both the inlet and exhaust openings on the chassis.
- The site should be as dust-free as possible. Dusty environments can clog the air filter, reducing the cooling airflow through the system. This can cause an over temperature condition in the router.

Under extreme environment conditions, the environmental monitoring system will shut down the power to protect the system components.

Figure 2-4 Cisco XR 12404 Router Air Circulation System

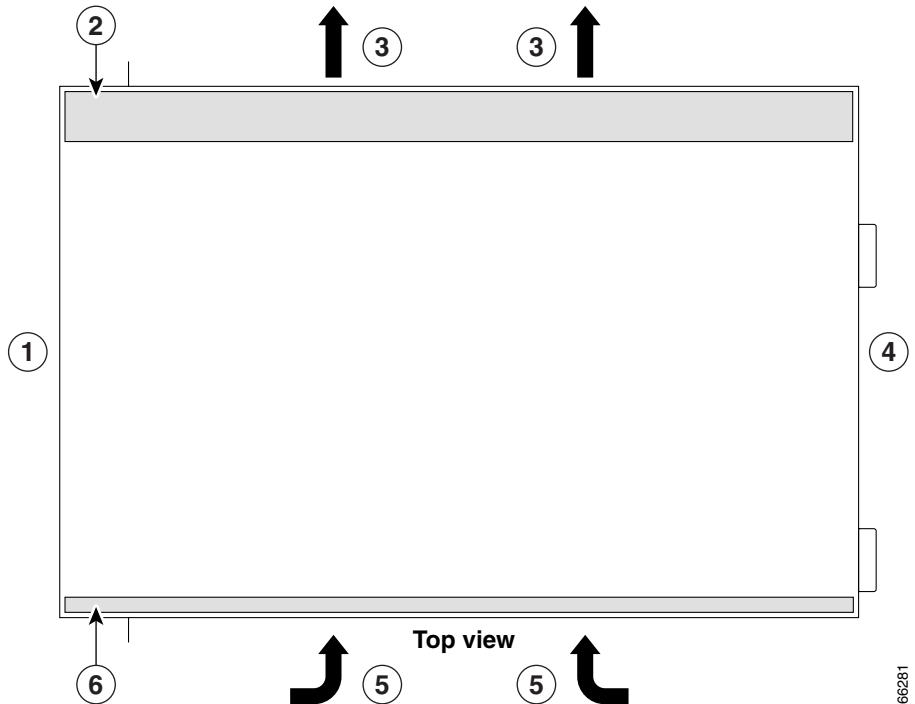

Temperature and Humidity

The operating environmental site requirements are listed in Appendix A. The temperature and humidity ranges listed are those within which the router will continue to operate. You can maintain normal operation by anticipating and correcting environmental irregularities before they approach critical values.

The environmental monitoring functionality built into the router protects the system and components from potential damage from overvoltage and overtemperature conditions.

Power Connection Guidelines

The Cisco XR 12404 Router requires an AC PEM or a combination DC PDU and DC PEM. Site requirements differ depending on the type of power source voltage. We recommend you follow these precautions and recommendations when planning power source connections to your router.

- Check the power at your site before installation and periodically after installation to ensure that you are receiving clean power from the power source.
- If necessary, install a power conditioner.
- Install proper grounding, or use the proper grounding receptacle located on the side of the chassis, to avoid damage from lightning and power surges.

AC-Powered Routers

A Cisco XR 12404 Router configured with two AC PEMs, are shipped with a three-wire electrical grounding-type plug that will only fit into a grounding-type power outlet. This is a safety feature. The equipment grounding should be in accordance with local and national electrical codes.

At sites where the Cisco XR 12404 Router operates with AC PEMs, observe the following guidelines (Figure 2-3):

- A power factor corrector (PFC) allows the PEM to accept AC power source voltage from an AC power source operating between 100 to 120 VAC, 15–Amp service in North America; and a range of 185 to 264 VAC, 10–Amp service, in an international environment.
- All AC PEM power cords measure 14 feet (4.3 meters).
- Provide a dedicated power source for each PEM installed in the router.
- Install an uninterruptible power source where possible.



Caution

Use the North American plug L6-20 20A only on 240 volt systems.

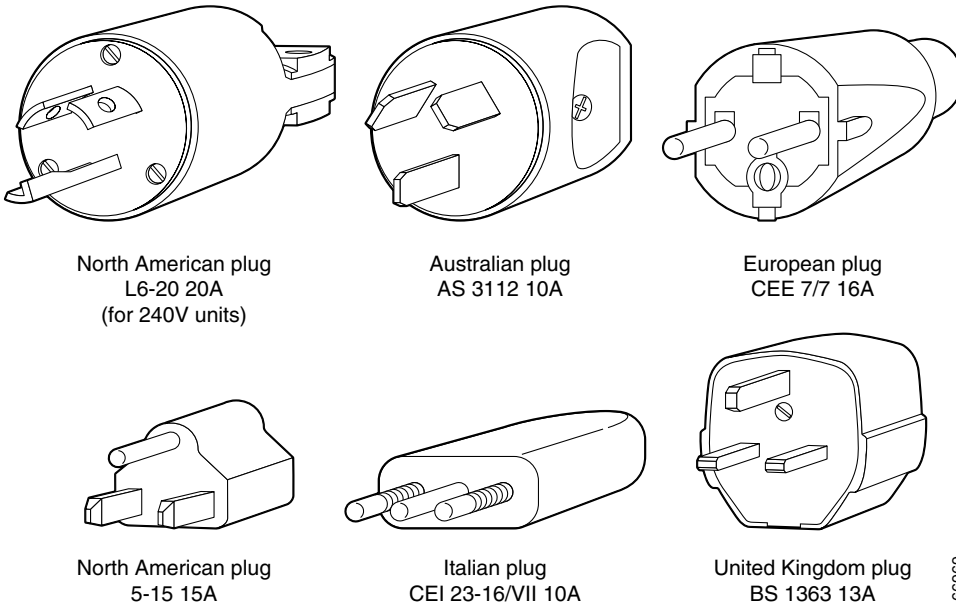
Figure 2-5 Cisco XR 12404 Router AC Power Plugs

Power Connection Guidelines for DC-Powered Routers

When the Cisco XR 12404 Router operates with a DC PDU, observe these guidelines:

- A Cisco XR 12404 Router configured with a DC PDU and DC-input PEMs has a maximum power rating of 35A per power module and requires a dedicated DC power source to support this maximum current. The facility DC source circuit breaker protection needs to comply with safety local codes and regulations. This circuit breaker protects against short-circuit and overcurrent faults in accordance with United States National Electrical Code NFPA 70 (United States), Canadian Electrical Code, part I, CSA C22.1 (Canada), and IEC 364 (other countries).
- DC power cable leads should be #6 American Wiring Gauge (AWG) high-strand-count wire.
- Provide a dedicated power source for each power entry module installed in the router.

- Install an uninterruptable power source where possible.

Grounding Connections

Before you connect power or turn on your Cisco XR 12404 Router, you must provide an adequate system ground for the router. The equipment grounding should be in accordance with local and national electrical codes.

For installations other than in a network equipment building system (NEBS) environment, you may choose to rely on the safety earth ground connection supplied via the International Electrotechnical Commission (IEC) 320 inlets for AC-powered units and the main terminal block ground connection for DC-powered units.

Site Wiring

This section offers site wiring guidelines for setting up the plant wiring and cabling at your site. When planning the location of the new system, consider the following:

- Electromagnetic interference (EMI)
- Distance limitations for signaling and unshielded conductors

Electromagnetic Interference

Electromagnetic interference can occur between the signal on the wires and external or ambient EMI fields when the wires are run for any significant distance. This fact has two implications for the construction of plant wiring.

- Bad wiring practice can result in radio interference emanating from the plant wiring.



Warning

Strong EMI, especially when it is caused by lightning or radio transmitters, can destroy the signal drivers and receivers in the Cisco XR 12404 Router, and can create an electrical hazard by conducting power surges through lines and may cause damage to the equipment.

**Note**

To predict and remedy strong EMI, you may need to consult experts in radio frequency interference (RFI).

If you use twisted-pair cable in your plant wiring with a good distribution of grounding conductors, the plant wiring is unlikely to emit radio interference. If you exceed the recommended distances, use a high-quality twisted-pair cable with one ground conductor for each data signal when applicable.

Distance Limitations

If wires exceed recommended distances, or if wires pass between buildings, give special consideration to the effect of a lightning strike in your vicinity. The electromagnetic pulse (EMP) caused by lightning or other high-energy phenomena can easily couple enough energy into unshielded conductors to destroy electronic devices. If you have had problems of this sort in the past, you may want to consult experts in electrical surge suppression and shielding.

Most data centers cannot resolve the infrequent but potentially catastrophic problems just described without pulse meters and other special equipment. These problems can cost a great deal of time to identify and resolve, so take precautions by providing a properly grounded and shielded environment, with special attention to issues of electrical surge suppression.

Unpacking and Repacking the Cisco XR 12404 Router

The shipping package for Cisco XR 12000 Series Routers is engineered to reduce the potential of product damage associated with routine material handling experienced during shipment. To minimize potential damage to the product, transport these products in their Cisco-specified packaging. Failure to do so may result in damage to the router or degradation of its performance. Also, do not remove the Internet router from its shipping container until you are ready to install it. The router should always be transported or stored in an upright position. Keep the router in the shipping container until you have determined where you will install it.

If you do not receive everything you ordered, contact a customer service representative for assistance. See the section titled, “Obtaining Documentation, Obtaining Support, and Security Guidelines” section on page -xii.

Transporting a Cisco XR 12000 Series Router

The shipping package for Cisco XR 12000 Series Routers is engineered to reduce the potential of product damage associated with routine material handling experienced during shipment. To minimize potential damage to the product, transport these products in their Cisco-specified packaging. Failure to do so may result in damage to the router or degradation of its performance. Also, do not remove the Internet router from its shipping container until you are ready to install it. The router should always be transported or stored in an upright position. Keep the router in the shipping container until you have determined a location for installation.

Site Preparation Checklist

Your Cisco XR 12404 Router is shipped with a site log (Table 2-1). Keep your site log in a location near the router where anyone who performs tasks can have access to it. Site log entries might include the following.

- Installation Progress—Make entries in the site log to record installation progress. You can note any difficulties encountered and remedies during the installation process.
- Upgrades, Removals, and Replacement Procedures—Use the site log as a record of system maintenance and expansion history.
 - FRU installed, removed, or replaced
 - Cisco XR 12404 Router configuration changes
 - Software upgrades
 - Corrective or preventive maintenance procedures performed
 - Intermittent problems
 - Your comments

Table 2-1 shows a sample site log. You can make copies of the sample or design your own site log.

Table 2-1 *Sample Site Log*

Date	Description of Action Performed or Symptom Observed	Initials



CHAPTER 3

Installing the Router

This chapter describes how to install a Cisco XR 12404 Router. It includes the following sections:

- Installing a Cisco XR 12404 Router, page 3-2
- Connecting RP and Line Card Cables, page 3-12
- Connecting to the Console Port and Auxiliary Ports, page 3-14
- Connecting to an AC Power Source, page 3-23
- Connecting to a DC Power Source, page 3-25
- Powering on the Router for the First Time, page 3-28
- External Network Interface, page 3-32
- Manually Booting the System, page 3-32

Required Tools

You need the following items to install the Cisco XR 12404 Router:

- Number 2 Phillips screwdriver
- Small flat-bladed screwdriver
- Tape measure (optional)
- Level (optional)

Installing a Cisco XR 12404 Router

This section provides the procedures for installing the Cisco XR 12404 Router in a rack or on a flat surface. It contains the following procedures:

- Installing the Rack-Mounting Brackets—Optional
- Installing the Chassis in a Rack
- Installing the Chassis on a Tabletop or Flat Surface
- Installing the Chassis on a Tabletop or Flat Surface

Your installation site should already be prepared before you begin installing the router. For complete information about site preparation see Chapter 2, “Preparing for Installation.”

Make sure that you have considered the following before you install the router:

- Mounted at the left side of the chassis is the fan tray, the exhaust vents should not be blocked.
- Facing the rear of the router, mounted on the left side is the air filter; air flow to the air filter should not be blocked.
- 24 inches (61 centimeters) of clearance in front of the chassis may be needed for working with line cards, attaching Network Interface Cables (NICs), the CSF or the RP.
- Location is temperature-controlled, air-conditioned and dust-free.
- Power cables and power supplies have been checked for compatibility with your power service.

- Labels on the equipment have been checked to ensure that the power service at your site is suitable for the Cisco XR 12404 Router.
- AC and DC power source voltage receptacles are easy to reach.

Installing the Rack-Mounting Brackets—Optional

The rack-mounting brackets temporarily bear the weight of the router while it is being positioned in the rack.

While the use of the rack-mounting is optional, installing them makes it much easier to mount the router in a rack, and also ensures that the router is level. The rack-mounting brackets can be left in place following the router installation.



Warning

Two or more people should install the router to minimize the risk of personal injury and damage to the equipment.

Refer to Figure 3-1 and use the following procedure to install the rack-mounting brackets.

-
- Step 1** Measure and mark the hole at the same height on both the left and right rack rails.
 - Step 2** Hold the right bracket against the right mounting rail and align the bottom screw hole in the bracket with the marked screw hole.
 - Step 3** While supporting the bracket against the mounting rail with one hand, use the other hand to insert a screw through a hole in the rack-mounting bracket.
 - Step 4** Finger-tighten the screw.
 - Step 5** Insert a second screw in the top hole in the bracket and finger tighten the screw.
 - Step 6** Mount the left rack-mounting bracket the same as you mounted the right bracket.
 - Step 7** Measure the two brackets to ensure they are positioned at the same height.
 - Step 8** Use a level to ensure the tops of the two brackets are level, or use a measuring tape to ensure that each bracket is the same distance from the top of both rack rails.
 - Step 9** Use a screwdriver to tighten all the screws (Figure 3-1).

Figure 3-1 Rack-Mounting Brackets

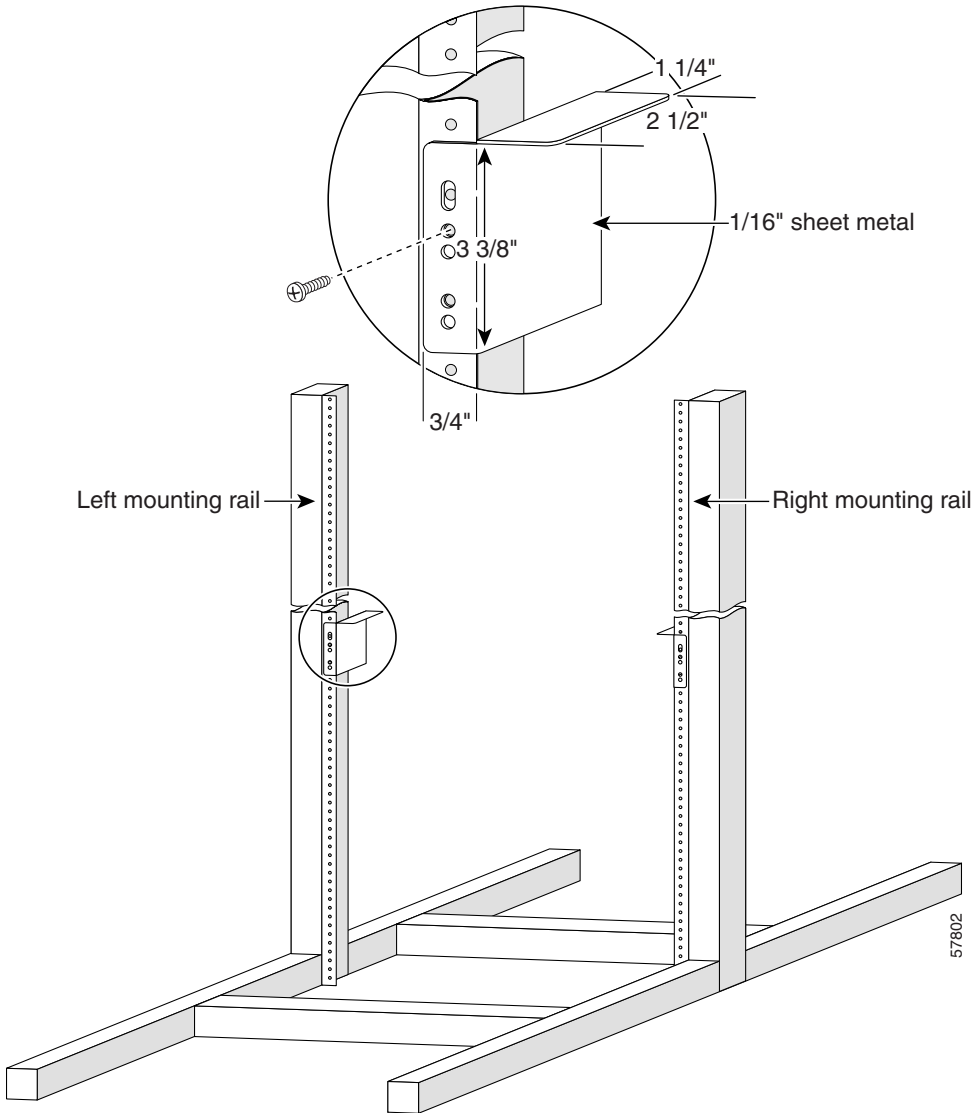

Installing the Center-Mounting Brackets—Optional

If you plan to install the Cisco XR 12404 Router in the center-mounting position, you must first install the center-mounting brackets on the equipment rack rails, then secure the chassis to the center-mounting brackets. If you do not plan to use the optional center-mounting brackets, proceed directly to the “Installing the Chassis in a Rack” section on page 3-7.

The optional center-mounting bracket installation kit ships in an accessories box included in the Cisco XR 12404 Router shipping container.

Refer to Figure 3-2 and use the following procedure to install the optional center-mounting brackets.

-
- Step 1** Measure and mark the hole at the same height on both the left and right posts.
 - Step 2** Hold the right bracket against the right rack rail and align the bottom screw hole in the bracket with the marked screw hole.
 - Step 3** While supporting the bracket against the rack rail with one hand, use the other hand to insert a screw through a hole in the center-mounting bracket that aligns with a hole on the rack rail.
 - Step 4** Use your fingers to tighten the screw.
 - Step 5** Insert a second screw in the top hole in the bracket and finger tighten the screw.
 - Step 6** Use a screwdriver to tighten all the screws.
 - Step 7** Mount the left center-mounting bracket so that it is at the same height as the right bracket.
 - Step 8** Use a level to ensure the two brackets are level; or use a measuring tape to ensure the both center-mounting brackets are the same distance from the top of both rack mounting rails.
 - Step 9** Use a screwdriver to tighten all the screws.

Figure 3-2 Center-Mounting Brackets

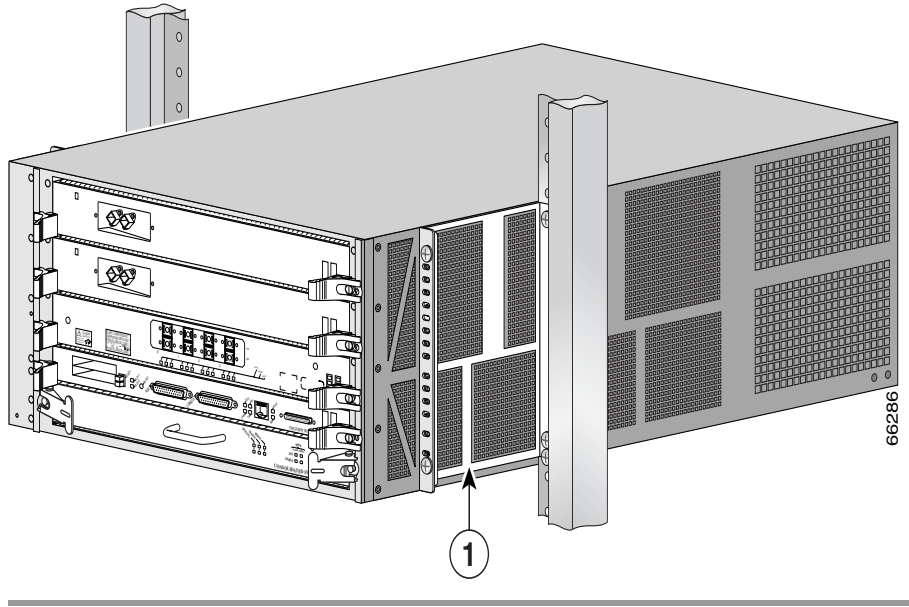

Installing the Chassis in a Rack

Use the following procedure to install the Cisco XR 12404 Router in a rack.

**Warning**

Two or more people should install the router to minimize the risk of personal injury and damage to the equipment.

Step 1 Move the router as close to the installation location as possible without interfering with the installation process.

Step 2 With one person lifting from the front and one from the rear of the chassis, lift the chassis off the pallet and position the chassis in the rack.



Note A third person might be needed to assist in lifting and positioning the chassis in the rack, or to install the screws once the chassis is in position.

Step 3 Install the screws to secure the chassis to the rack

- a. Look at the bottom mounting holes on the chassis. Align one of the holes with a mounting hole in the rack.
- b. Install one of the mounting screws provided.
- c. On the other side of the chassis adjust the position of the chassis so that the same mounting hole in the bottom group of mounting holes is aligned with a hole in the rack.
- d. Install one of the mounting screws provided.

Step 4 Repeat Step 3a through Step 3d for additional mounting holes.

Step 5 Use a screwdriver to tighten all the screws.

Installing the Chassis on a Tabletop or Flat Surface

Use the following procedure to install the Cisco XR 12404 Router on a tabletop or other stable flat surface.

-
- Step 1** Move the router as close to the installation location as possible.
- Step 2** With one person positioned at the front and rear of the chassis, lift the chassis off of the pallet and position the chassis on the flat surface.
- Step 3** Secure the chassis to the flat surface to ensure it does not fall off.
- You can use the same mounting hardware that secured your router to the shipping pallet to secure the chassis to the flat surface.
-

Supplemental Bonding and Grounding Connections

Before you connect power or turn on your Cisco XR 12404 Router, you must provide an adequate system ground for the router. The equipment grounding should be in accordance with local and national electrical codes.

If you are not installing the Cisco XR 12404 Router in a NEBS environment, you can choose to bypass these guidelines and rely on the safety earth ground connection supplied via the 5-15 15A North American plug to the AC-powered PEMs, and the main terminal block ground connection for DC-powered PEMs.

- On Cisco XR 12404 Routers configured for AC-input operation, the AC PDU is equipped with a three-wire electrical grounding-type connector that accept three-wire, grounding-type AC power cords such as the power cords shipped with the router. This is a safety feature.

- On Cisco XR 12404 Routers configured for DC-input operation, the DC PDU is equipped with a DC power connector block with wire-connection terminals for connecting the negative lead (top terminal), the positive lead (middle terminal), and the ground lead (bottom terminal). This is a safety feature.

**Note**

Cisco XR 12404 Router grounding architecture conforms to the DC-I (DC-isolated) method of grounding as described in Telcordia GR-1089-CORE. A DC-I architecture means that there is no connection between the DC return terminal and the frame ground. DC return and frame ground are isolated from one another at the router.

If the router is installed in a NEBS environment, we strongly recommend that you connect the central office ground system or interior equipment grounding system to the supplemental bonding and grounding point on the router chassis. This grounding point consists of threaded inserts is located on the side of the chassis near the back of the chassis (see Figure 3-3). It is also referred to as the NEBS bonding and grounding receptacle, and is intended to satisfy the Telcordia NEBS requirements for supplemental bonding and grounding connections.

Figure 3-3 Supplemental Bonding and Grounding Port for NEBS Compliance

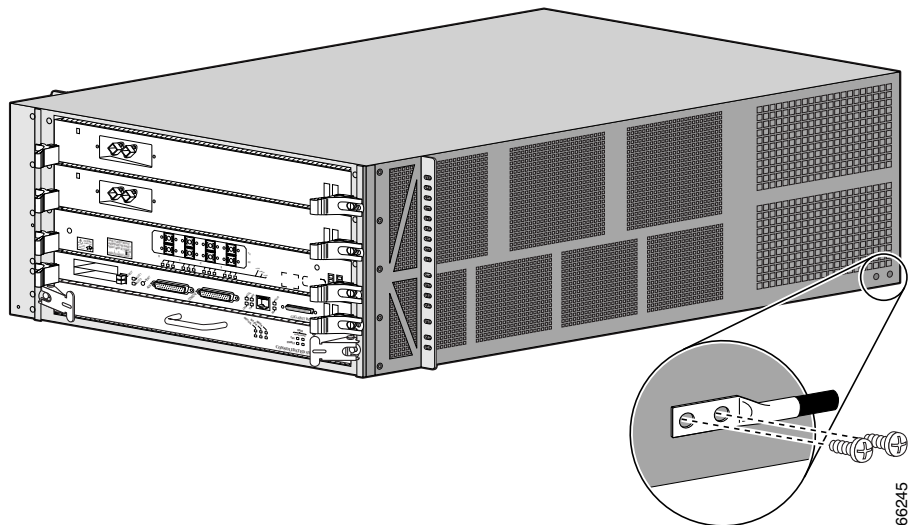

Use a cable lug with two holes at 0.63" (16 mm) centers to connect to the chassis with two 6.3 mm (M6) screws as shown in Figure 3-4. The lug can be ordered from Cisco (Part Number 32-0607-01).

Figure 3-4 Cable Lug

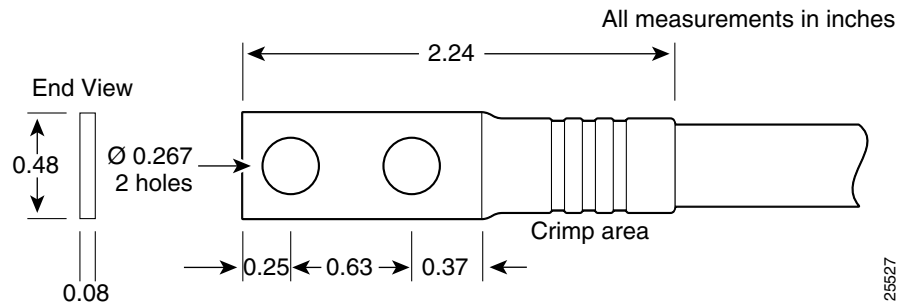

The dual-hole lug is crimped onto a grounding wire of a wire size and length determined by your router location and facility environment. The crimping tool shown in Figure 3-5 is a standard crimping tool obtainable from any normal hardware source.

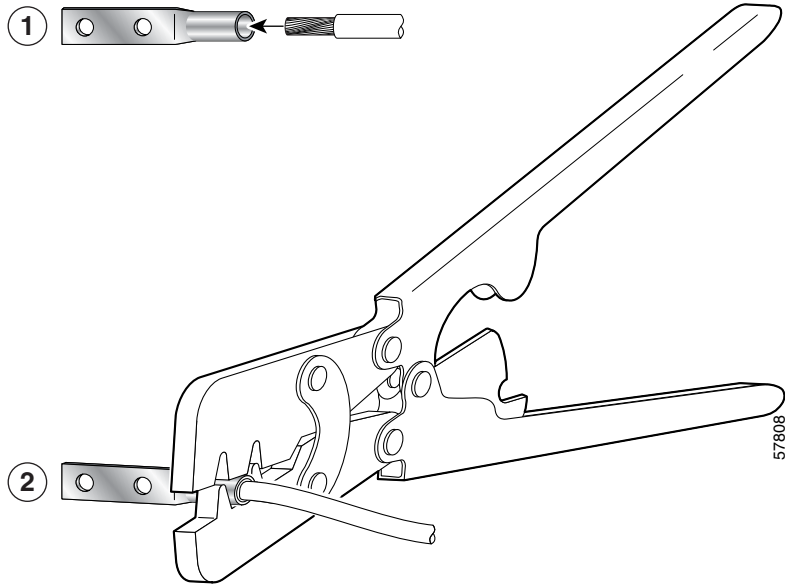
Figure 3-5 Crimping the Lug

- | | | | |
|---|------------------------------|---|---------------|
| 1 | Place ground wire in the lug | 2 | Crimp the lug |
|---|------------------------------|---|---------------|

Connecting RP and Line Card Cables

Use the following procedure to connect RP and line card cables to the router.

- Step 1** Proceeding from left to right identify the network interface cable that connects to each card port.
- Step 2** Connect the network interface cables:
 - a. Carefully route the identified cable through the cable-management tray and over to the card interface port; connect one cable at a time (Figure 3-6).
 - b. Proceeding from left to right carefully wrap the cables using the velcro straps.

Figure 3-6 RP and Line Card Cable-Management Brackets

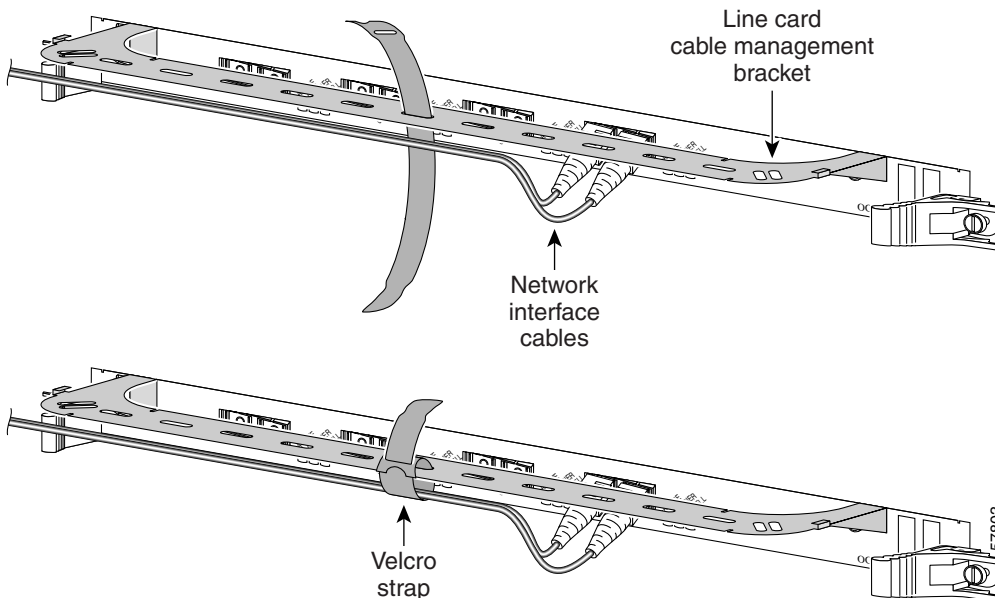

**Caution**

Carefully adjust the interface cable in the RP or line card cable-management bracket to prevent any kinks or sharp bends in the interface cable. Kinks and sharp bends can destroy or degrade the ability of the optical fiber to propagate the signal-encoded beam of light accurately from one end of the cable to the other. Also, allow adequate strain relief in the interface cable.

Step 3

Route the cable to the chassis cable-management bracket mounted to the left side of the chassis (Figure 3-7).

- Use the screws packaged with the chassis cable management bracket kit.

Figure 3-7 Chassis Cable-Management Bracket

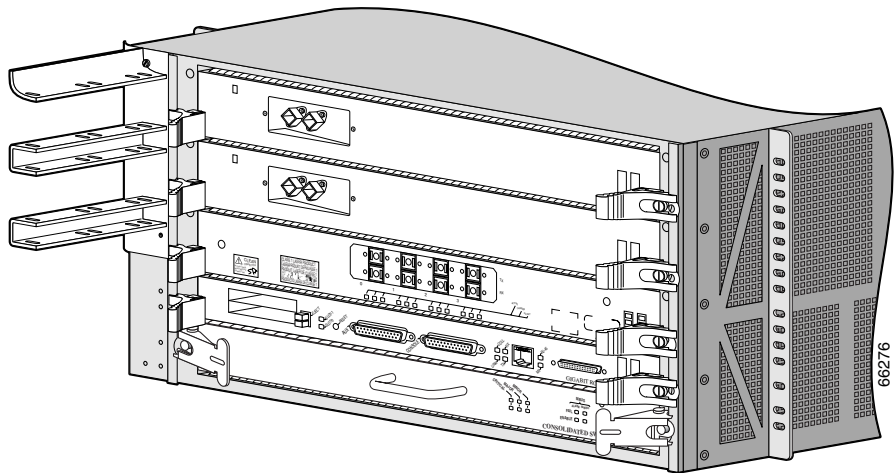

Connecting to the Console Port and Auxiliary Ports

This section provides the information to connect a console to the router. Both Data Set Ready (DSR) and Data Carrier Detect (DCD) signals are active when the system is running. The console port does not support modem control or hardware flow control. The console port requires a straight-through EIA/TIA-232 cable.

The system console port on the PRP is a DCE RJ-45 receptacle for connecting a data terminal, which you must configure. The console port is labeled *Console*, as shown in Figure 3-8.

**Note**

To comply with Telcordia GR-1089 NEBS standard for electromagnetic compatibility and safety, connect all console, auxiliary, Ethernet, and BITS interfaces only to intrabuilding or non-exposed wiring or cabling. The intrabuilding cable must be shielded and the shield must be grounded at both ends.

Check your terminal's documentation to determine the baud rate of the terminal you plan to use. If your documentation does not specify settings use the following terminal settings:

1. Baud to 9600
2. Data bits to 8
3. Parity to no parity
4. Stop bits to 2

The console port requires a straight-through RJ-45 cable.

Figure 3-8 PRP Console and Auxiliary Port Connections

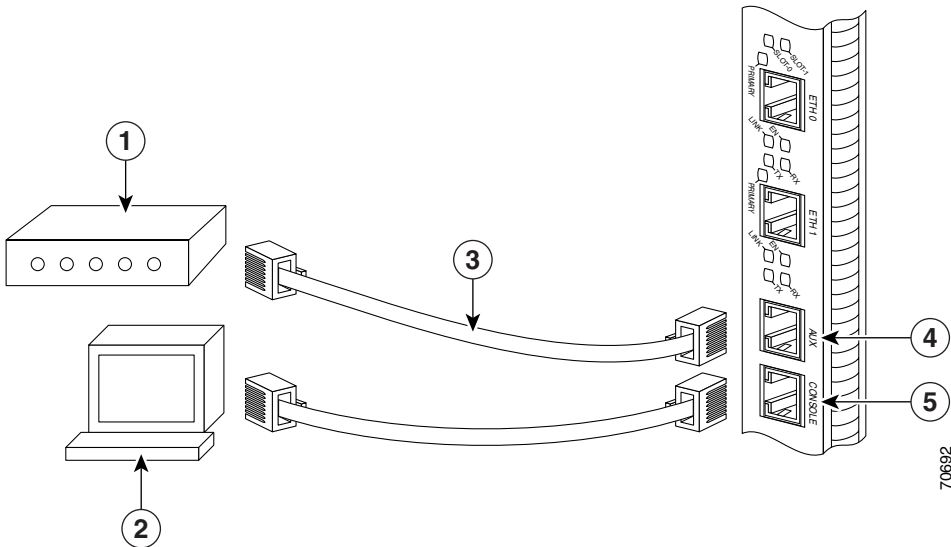

1	Modem	4	Auxiliary port
2	Console terminal	5	Console port
3	RJ-45 Ethernet cables		

**Note**

The console and auxiliary ports are both asynchronous serial ports; any devices connected to these ports must be capable of asynchronous transmission. (Asynchronous is the most common type of serial device; for example, most modems are asynchronous devices.)

PRP Console Port Signals

The console port on the PRP is a DCE RJ-45 receptacle. Table 3-1 lists the signals used on this port.

Table 3-1 PRP Console Port Signals

Console Port Pin	Signal	Input/Output	Description
1 ¹	—	—	—
2	DTR	Output	Data Terminal Ready
3	TxD	Output	Transmit Data
4	GND	—	Signal Ground
5	GND	—	Signal Ground
6	RxD	Input	Receive Data
7	DSR	Input	Data Set Ready
8 ¹	—	—	—

1. These pins are not connected.

PRP Auxiliary Port Signals

The auxiliary port on the PRP is a DTE, RJ-45 plug for connecting a modem or other DCE device (such as a CSU/DSU or another router) to the router. The port is labeled *Aux*, as shown in Figure 3-8. The asynchronous auxiliary port supports hardware flow control and modem control. Table 3-2 lists the signals used on the auxiliary port.

Table 3-2 PRP Auxiliary Port Signals

Auxiliary Port Pin	Signal	Input/Output	Description
1	RTS	Output	Request To Send
2	DTR	Output	Data Terminal Ready
3	TxD	Output	Transmit Data
4	GND	—	Signal Ground
5	GND	—	Signal Ground
6	RxD	Input	Receive Data
7	DSR	Input	Data Set Ready
8	CTS	Input	Clear To Send

Installing a Flash Memory Card

By default, a Flash memory card containing a valid Cisco IOS XR software image is inserted in bottom slot, PCMCIA slot 0 before the router is shipped.



Note

PCMCIA slot 0 is the bottom slot and slot 1 is the top slot. Both Flash memory card slots on each RP can be used at the same time.

The software configuration register is set to 0x0102, which causes the router to boot automatically from the Cisco IOS XR software image stored on the Flash memory card.

- The Flash memory card that shipped with your system is installed in the bottom slot, PCMCIA slot 0 of the RP (Figure 3-9).

Figure 3-9 Flash Memory Card Slots

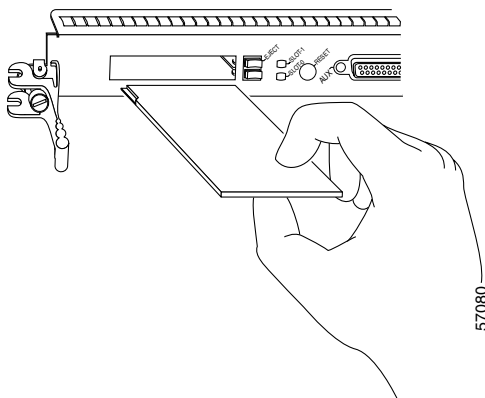

Ensure that a console terminal is connected to the RP console port and turned on, or that you have a remote login to the router from another device through a telnet session.

Connecting the PRP to an Ethernet Network

The PRP includes two 10/100 Mbps Ethernet ports, each using an 8-pin RJ-45 receptacle for either IEEE 802.3 10BASE-T (10 Mbps) or IEEE 802.3u 100BASE-TX (100 Mbps) connections. The transmission speed of the Ethernet ports is auto-sensing by default and is user configurable.

To connect cables to the PRP Ethernet interfaces (ports labeled ETH0 and ETH1), attach the Category 5 UTP cable directly to a RJ-45 receptacle on the PRP.



Note

The Ethernet interfaces on the PRP are end-station devices, not repeaters; therefore, you *must* connect an Ethernet interface to a repeater or hub.

RJ-45 cables are not available from Cisco Systems, but are available from outside commercial cable vendors.

**Note**

Only connect cables that comply with EIA/TIA-568 standards. See Table 3-4 and Table 3-5 for cable recommendations and specifications.

**Note**

To comply with Telcordia GR-1089 NEBS standard for electromagnetic compatibility and safety, connect all console, auxiliary, and Ethernet interfaces only to intrabuilding or non-exposed wiring or cabling. The intrabuilding cable must be shielded and the shield must be grounded at both ends.

**Caution**

The Ethernet ports are primarily used as a Telnet port into the Cisco XR 12000 Series Router, and for booting or accessing Cisco IOS XR software images over a network to which an Ethernet port is directly connected. Cisco Express Forwarding (CEF) functions are switched off by default for security reasons. Cisco strongly cautions you to consider the security implications of switching on CEF routing functions on these ports.

Figure 3-10 is an example of the functionality of an Ethernet port. In this example, you cannot access Network 2.0.0.0 through the Ethernet port (ETH0) on the PRP in router A; you can only access the hosts and router C, which are in Network 1.0.0.0 (see dotted arrows in Figure 3-10).

To access Network 2.0.0.0 from router A, you must use an interface port on one of your line cards (in this example, a Packet-over-SONET (POS) line card in router A) to go through router B, through router C, and into Network 2.0.0.0 (see solid arrows in Figure 3-10).

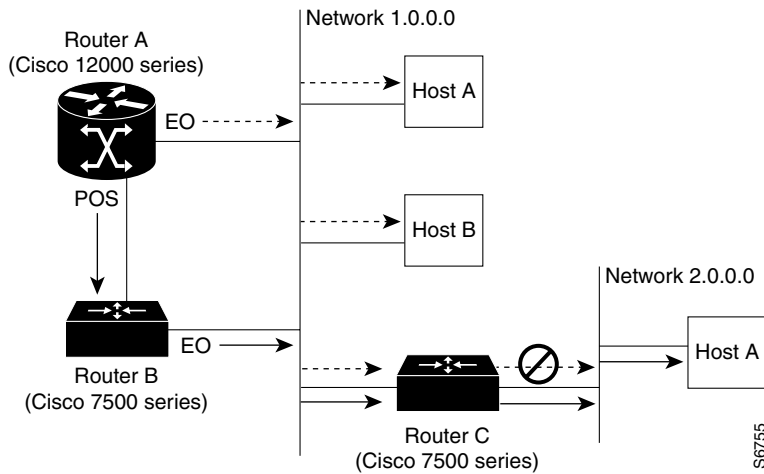
Figure 3-10 Using the Ethernet Port on the PRP

S6755

PRP Ethernet Connections

Figure 3-11 shows a PRP RJ-45 receptacle and cable connectors. The RJ-45 connection does not require an external transceiver. The RJ-45 connection requires Category 5 unshielded twisted-pair (UTP) cables, which are not available from Cisco Systems, but are available from commercial cable vendors. Table 3-3 lists the port pinouts for the RJ-45 receptacle.

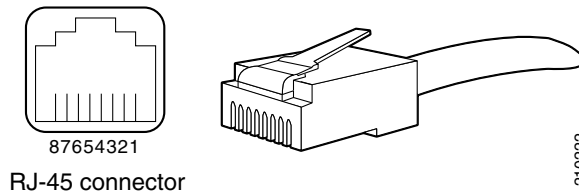
Figure 3-11 RJ-45 Receptacle and Plug (Horizontal Orientation)

RJ-45 connector

210222

**Warning**

The ports labeled Ethernet, 10BASE-T, Token Ring, Console, and AUX are safety extra-low voltage (SELV) circuits. SELV circuits should only be connected to other SELV circuits. Because the BRI circuits are treated like telephone-network voltage, avoid connecting the SELV circuit to the telephone network voltage (TNV) circuits.

Table 3-3 PRP RJ-45 Ethernet Receptacle Pinout

Ethernet Port Pin	Signal	Description
1	TxD+	Transmit data +
2	TxD-	Transmit data -
3	RxD+	Receive data +
4	Termination Network	No connection
5	Termination Network	No connection
6	RxD-	Receive data -
7	Termination Network	No connection
8	Termination Network	No connection

Depending on your RJ-45 cabling requirements, use the cable pinouts shown in Figure 3-12 or Figure 3-13.

Figure 3-12 Straight-Through Cable Pinout—Connecting MDI Ethernet Port to MDI-X Wiring

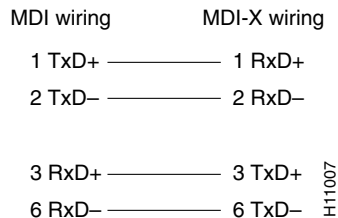

Figure 3-13 Crossover Cable Pinout (for Connecting Two PRPs)

Table 3-4 lists the cabling specifications for 100-Mbps transmission over unshielded twisted-pair (UTP) cables.

**Note**

The transmission speed of the Ethernet ports is auto-sensing by default and is user configurable.

Table 3-4 Specifications and Connection Limits for 100-Mbps Transmission

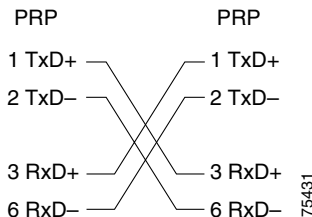
Parameter	RJ-45
Cable specification	Category 5 ¹ UTP, 22 to 24 AWG ²
Cable length (max)	—
Segment length (max)	328 feet (100 m) for 100BASE-TX
Network length (max)	656 feet (200 m) ³ (with 1 repeater)

1. EIA/TIA-568 or EIA-TIA-568 TSB-36 compliant. Not supplied by Cisco.
2. AWG = American Wire Gauge. This gauge is specified by the EIA/TIA-568 standard.
3. This length is specifically between any two stations on a repeated segment.

Table 3-5 lists IEEE 802.3u physical characteristics for 100BASE-TX.

Table 3-5 IEEE 802.3u Physical Characteristics

Parameter	100BASE-TX
Data rate (Mbps)	100
Signaling method	Baseband
Maximum segment length	100 m between DTE ¹ and repeaters
Media	Category 5 UTP (for RJ-45)
Topology	Star/Hub

1. DTE = data terminal equipment.

Connecting to an AC Power Source

This section provides the procedure for connecting your router to an AC power source. A power factor corrector (PFC) allows the AC-input power supply to accept AC power source voltage from an AC power source operating between 100-120 VAC, 15-Amp service in North America; and a range of 185-264 VAC, 10-Amp service in an international environment.



Caution

The AC PEM weighs 14.0 pounds (6.35 kg.). Use two hands when handling a PEM.

-
- Step 1** Attach an ESD-preventive strap to yourself and to either the chassis, or to a bare metal surface.
- Step 2** Using two hands to support and guide the PEM, slide it into the PEM bay. Push the PEM all the way into the bay until the PEM connector engages the backplane connector.

Step 3 Tighten the captive screws on the PEM faceplate (Figure 3-14).

Figure 3-14 AC PEM

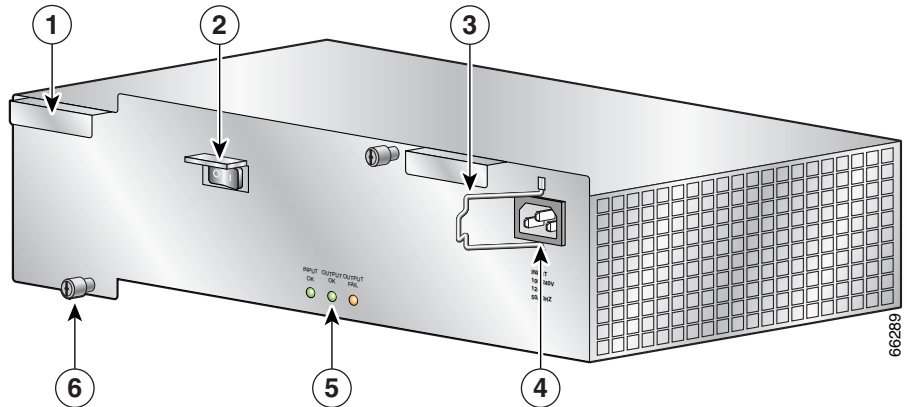

1	AC PEM handle	4	Power cord receptacle
2	On/Off switch	5	LEDs
3	Bail latch	6	Captive screws

- All electrical connections between the power supply and the backplane are made automatically when the power supply is fully inserted in the power supply bay.

Step 4 Locate the AC power cord and remove it from its shipping packaging. Verify that the AC power cord shipped with the power supply is the correct type for your site.



Note If you have an incorrect type of power cord, contact your service representative for a replacement.

Step 5 Plug the AC power cord into the AC PEM.

Step 6 Connect the other end of the AC power cord to the AC power source outlet.



Note We recommend attaching each AC PEM to an independent power source for full redundancy. We also recommend that you use an uninterruptable power source (UPS) to protect against power failures at your site.



Note When operating your router on an AC power source, both PEM bays must have all AC PEMs installed to ensure compliance with regulatory EMI standards.

Connecting to a DC Power Source

Each DC PDU should be connected to separate DC sources using six threaded terminals. Two terminals for negative (source DC), two terminals for positive (source DC return), and two terminals for ground. The DC power cable leads should be 6 American Wiring Gauge (AWG) high strand count wire. The PEM accepts DC power source voltage from a dedicated 35–Amp service DC power source operating between -48 to -60 VDC.



Warning

Power to your router must be Off and all cables disconnected before you install the DC power assembly. The DC PDU and DC PEM when connected, is not a hot-swappable field replaceable unit.



Note

We recommend each DC PDU be connected to an independent power source for full redundancy. We also recommend that you use an uninterruptable power source (UPS) to protect against power failures at your site.



Caution

The DC PEM and DC PDU assembly weighs 14.0 pounds (6.35 kg.). Use two hands when handling the power supply.

Use the following procedure to install the DC PEM and DC PDU in the router.

-
- Step 1** Attach an ESD-preventive strap to yourself and to either the chassis, or to a bare metal surface.
- Step 2** Insert the DC power module into the power module bay at the rear of the chassis (Figure 3-15).

Figure 3-15 DC Powered Cisco XR 12404 Router—Rear View

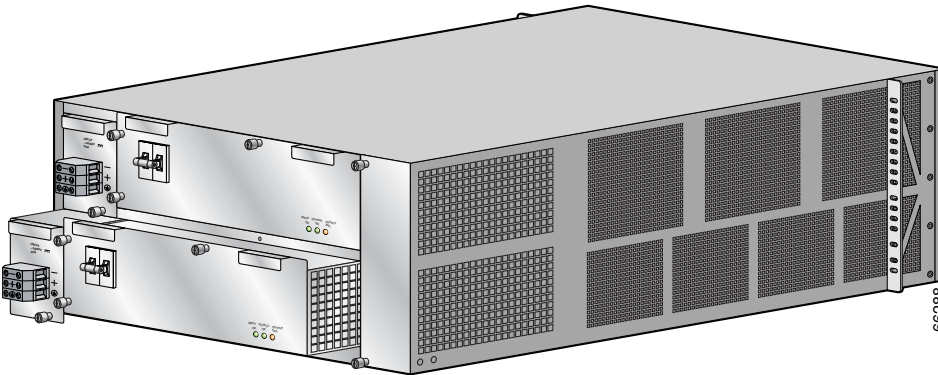

- Step 3** Press the module against the backplane until the connectors are seated against the backplane receptacles.
- Step 4** Tighten all of the captive screws on the faceplate.
All electrical connections between the power supply and the backplane happen automatically when the power supply is fully inserted in the power supply bay.
- Step 5** Tighten the captive screws on the DC PDU.

- Step 6** Secure each lead to the proper terminal port by tightening the terminal port connector screws with a 3/16-inch flat-blade screw driver (Figure 3-16).

Figure 3-16 DC PDU Power Block

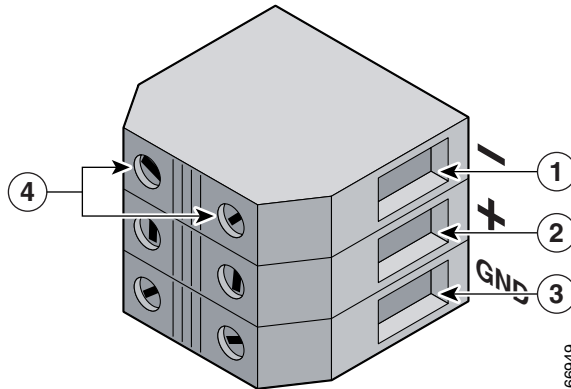

1	Negative Terminal Port	3	Ground Terminal Port
2	Positive Terminal Port	4	Terminal Port Connector Screws

- Step 7** Verify that the DC power source circuit breaker servicing the DC PEM is switched on.

Powering on the Router for the First Time

Use the following procedure to power on the router for the first time.

Step 1 Check the following list *before* you power on the router:

- All cards are fully inserted in the card and CSF cage and all captive screws are tight



Caution Do not overtighten the captive screws on the cards you might strip the threads on the screw or in the insert in the component faceplate.

- Line card cable-management brackets are attached to their respective line cards
- Interface cables are routed neatly through the line card cable-management bracket
- Interface cables are completely seated in their line card connectors
- Interface cables are routed neatly through the chassis cable-management bracket
- PEMs are fully inserted in to each AC PEM bay or DC PDU and DC PEM bay
- PEM cables are securely connected to the PEM
- Power cables are securely connected to the PDU, the power source and are secured with appropriate strain relief.
- Empty card slots or card bays are filled with card blanks to ensure proper air flow through the chassis and electromagnetic compatibility (EMC)

- Step 2** Power on the router by switching on all the circuit breakers and/or plug the power cord into an active power source that controls power to the router's AC PEM or DC power distribution unit (PDU).
- Step 3** You should observe the following LED confirmation:
- AC PEMs—Verify the AC PEM LEDs are on and that the status is OK (Figure 3-17).

Figure 3-17 AC PEM LEDs

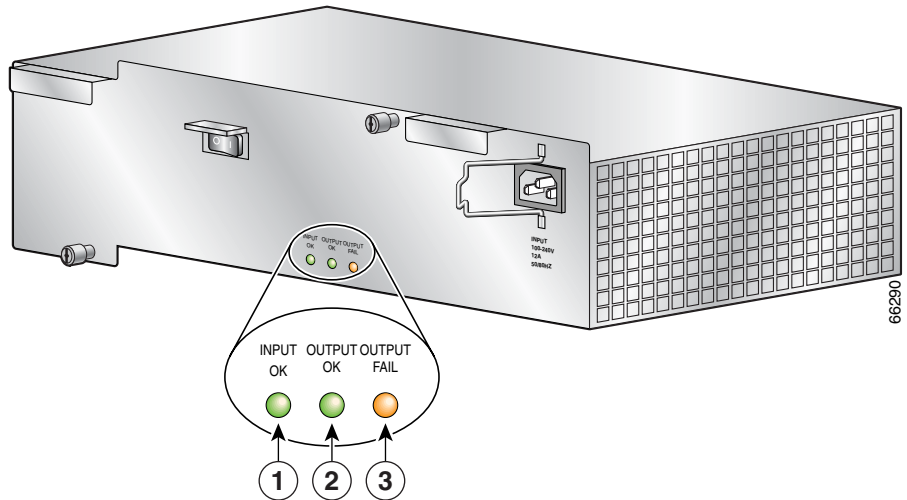

1	Input OK	Green	AC is present and within specified limits
2	Output OK	Green	Power supply module is operating normally in a powered up condition
3	Output Fail	Amber	Power module is operating in a fault condition and shutdown has occurred

- DC PEMs—Verify the DC PEM LEDs are on and that the status is OK (Figure 3-18).

Figure 3-18 DC PEM LEDs

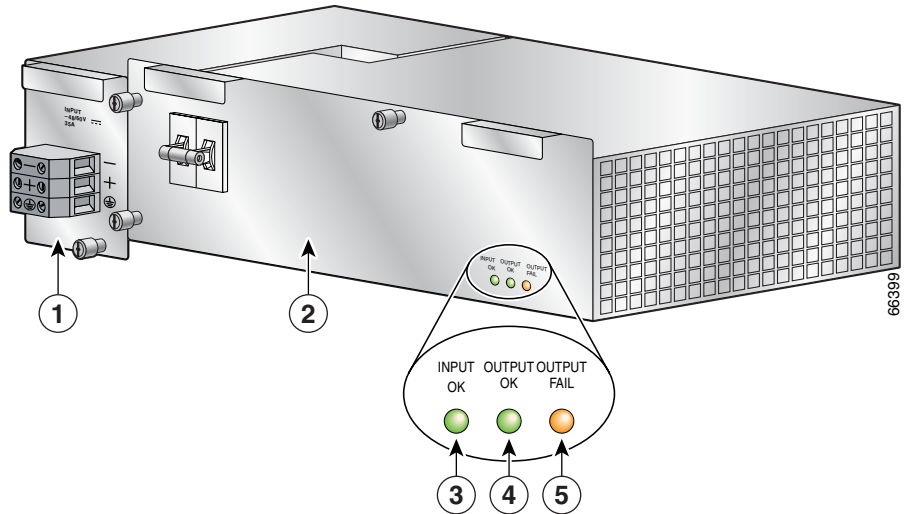

1	DC PDU	N/A	N/A
2	DC PEM	N/A	N/A
3	Input OK	Green	DC is present and within specified limits
4	Output OK	Green	Power supply module is operating normally in a powered up condition
5	Output Fail	Amber	Power module is operating in a fault condition and shutdown has occurred

- Visually check the CSF LEDs (Figure 3-19):

Figure 3-19 CSF LEDs

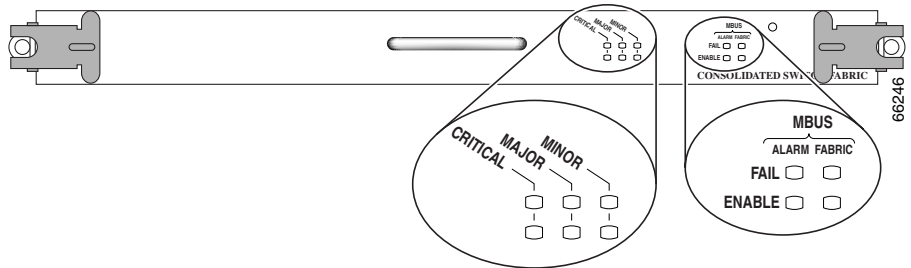

Table 3-6 CSF LEDs

Switch Fabric LEDs	Status	Condition
Critical	Off	Normally Off
Major	Off	Normally Off
Minor	Off	Normally Off

Table 3-7 CSF MBus Alarm LEDs

MBus Alarm LEDs	Status	Condition
Fail	Off	Normally Off
Enable	On	Normally On

Table 3-8 CSF MBus LEDs

MBus Fabric LEDs	Status	Condition
Fail	Off	Normally Off
Enable	On	Normally On

- Step 4** On the console terminal, verify that the console displays the system banner and that the system and all interfaces initialize successfully.
-

If the router does not power on, or if any interfaces do not initialize properly, see Chapter 4, “Troubleshooting the Installation.” If you are still unable to resolve the problem, contact your Cisco service representative for assistance.

External Network Interface

After configuration, the RP and line cards can communicate with external networks.

You do not need to configure the network interfaces immediately, but you cannot connect to a network until you configure the interfaces for operation in your networking environment.

**Note**

The interface-specific LEDs on the line cards go on when the line card interfaces are configured.

To verify correct operation of each line card interface, complete the first-time setup procedures and configuration, then check the status of the interfaces against the LED descriptions in the configuration notes for each line card.

If the system does not complete each of the boot process steps, go to “Chapter 4, “Troubleshooting the Installation.”

Manually Booting the System

If your router does not find a valid system configuration image, or if you interrupt the boot sequence, the system might enter read-only memory (ROM) monitor mode and display the ROM monitor prompt (rommon>). From ROM monitor mode, you have access to a number of commands to locate and boot a valid system image.



CHAPTER 4

Troubleshooting the Installation

This chapter provides troubleshooting guidelines for Cisco XR 12404 router. If the solutions provided in this chapter do not make the router fully functional, contact your Cisco service representative for assistance.

- Problem-Solving with Subsystems, page 4-5
- Identifying Startup Problems, page 4-2
- Troubleshooting an AC Power Subsystem, page 4-6
- Troubleshooting the DC Power Subsystem, page 4-9
- Troubleshooting the Processor Subsystem, page 4-13
- Troubleshooting the Cooling Subsystem, page 4-19

Identifying Startup Problems

Startup problems are commonly due to power source failures or to a card not properly seated in the backplane. Although an overtemperature condition is unlikely at initial startup, the environmental monitoring functions are included here because they also monitor internal voltages.

When you start up the router for the first time, you should observe the startup sequence. The normal startup sequence is as follows:

- Each card in the system has an MBus module and at least one DC-DC converter. Each MBus module controls the DC-DC converter. The MBus module receives +5 VDC directly from the power supplies through the backplane. When the power supply is powered on, each MBus module boots from an onboard electrically erasable programmable read-only memory (EEPROM) device. Each MBus module processor reads a set of identification pins on the card to the backplane connector telling the MBus module processor what kind of card it is mounted on, which in turn, determines how the MBus module will function.
- The consolidated switch fabric (CSF) containing the system clock, immediately powers up.
- The MBus module on the RP monitors the progress of the clock and scheduler card power on. When the CSF has powered up, the MBus module on the RP turns on its DC-DC converter powering up the RP.
- The RP sends instructions to each line card to power up. Each line card processor begins to perform its own boot process and notifies the RP when the boot process is complete through its MBus module.
- As the boot process progresses for each card, the status of the card is shown on the alphanumeric LED displays. The left display is powered by the DC-DC converter on the card; the right display is powered by the DC voltage that powers the MBus module.

By checking the state of the LEDs on the power supplies and the alphanumeric displays on the RP and line cards, you can determine when and where the system failed in the startup sequence.

Using the System LEDs to Troubleshoot

You can determine when and where the system failed in the startup sequence by checking the state of the LEDs on the power modules and line cards, and on the alphanumeric displays on the RP.

You should observe the following when you power on the router:

- **INPUT OK LEDs**—These LEDs should light immediately; they should remain on as long as the system is receiving power from the power source and the power switch is in the on position.

The LEDs indicate the status of the PEM and internal DC voltages. If either LED does not light, or if they shut off while the power switch is on, there could be a problem with either the power source, the internal DC voltage used to power internal components, or the cooling subsystem.

The LEDs remain on when all of the following conditions are met:

- **AC PEMs:** The AC power source voltage is operating between 100-120 VAC and is using 15-Amp service for North America, or is operating between 185-264 VAC and is using 10-Amp service in an international environment.
- **DC PEMs:** The DC power source is supplying power to the PEMs and the power switch is in the on position.



Note The amber OUTPUT FAIL LED is normally off, but lights if the PEM detects a fault.

- The power supplies are providing –48 VDC to internal components.

- All internal DC voltages are within tolerance.

If the AC power source or any of the internal DC voltages exceed allowable tolerances, the OUTPUT OK LED shuts off, or will shut off shortly after you turn on the power. Because both the RP (which uses +2.5, +3.3 and +5 VDC), and the fan tray assembly (which uses -48 VDC) are required for operation, a problem with any of the internal DC lines can prevent the system from starting up or continuing operation.

For example, if there is a problem with the -48 VDC line that supplies the fan tray, the system powers up, but will also recognize that the fans are not operating. The system will initiate a fan failure shutdown sequence, display the appropriate warning messages, and then shut down after two minutes.

If there is a problem with any of the other DC lines, the RP will not be able to initialize the system software, so the system might attempt to start up and fail during the boot sequence.

- The fan tray immediately begins operating.
- The alphanumeric LED displays on the RP indicate the following:
 - The left display indicates which RP software component is running.
 - The right display indicates the phase of the boot process that is currently occurring.

Problem-Solving with Subsystems

The key to solving router problems is to isolate the problem to a specific subsystem. The first step in solving startup problems is to compare what the system *is doing* to what it *should be doing*. Because a startup problem is usually attributable to a single component, it is more efficient to first isolate the problem to a subsystem rather than trying to troubleshoot each component in the system.

For troubleshooting purposes, the Cisco XR 12404 router consists of the following subsystems:

- Power subsystem—Includes the following components:
 - AC-input power supplies or DC-input power entry modules (PEMs). The Cisco XR 12404 router can be configured for source AC or source DC power (you can not mix AC and DC power).
 - Chassis backplane power distribution. The –48 VDC power from the power supplies is transferred to the chassis backplane, which distributes –48 VDC power to the cards in the card cages through the backplane connectors.
 - DC-DC converters. Each card in the router is equipped with DC-to-DC converters. These converters are controlled by the MBus module on each card. The DC-to-DC converters take –48 VDC and convert it into the voltages required by the card circuitry.
- Processor subsystem—The processor subsystem includes the RP and all line cards. The RP downloads a copy of the Cisco IOS XR image to each line card processor. The system uses alphanumeric LED displays to display status and error messages, which can help in troubleshooting.
- Cooling subsystem—The cooling subsystem is comprised of one fan tray assembly and one air filter. The fan tray assembly and air filter are hot swappable, and can be replaced while the system is running.



Caution

Replace the fan tray assembly within 2 minutes of removing it from the chassis or the router will go into a critical failure mode and shutdown due to an overtemp condition.

Troubleshooting an AC Power Subsystem

AC PEMs provide -48 VDC OUTPUT. The $+5$ VDC OUTPUT from the CSF powers the MBus module on each card in the system. The MBus module, in turn, control the DC-DC converters also present on each card in the system. The DC-DC converter takes -48 VDC from the power supply and converts it into $+2.5$, $+3.3$ and $+5$ VDC, which is distributed to the card circuitry.

AC PEMs are monitored by the MBus module and the RP for over- or undervoltage and over- or undercurrent conditions.

Begin checking the power subsystem by first looking at the LEDs on the power supply. The INPUT OK LED on an AC PEM lights when AC power is applied; the OUTPUT OK LED lights when the PEM power switch is turned on.

Figure 4-1 shows the location of the LEDs on the AC PEM (item 5).

Figure 4-1 AC PEM

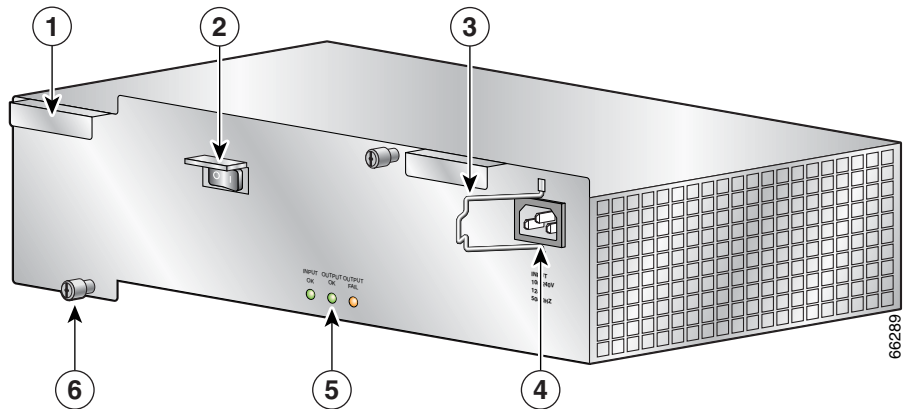

1	AC PEM handle	4	Power cord receptacle
2	On/Off switch	5	LEDs
3	Bail Latch	6	Captive screws

Table 4-1 summarizes the function of these indicators.

Table 4-1 DC-Input PEM LED Indicators

LED Label	Color	Function
OUTPUT OK	Green	PEM is operating normally in a powered-on condition.
INPUT OK	Green	DC power is present at the PEM input and within the specified limits.
OUTPUT FAIL	Amber	Indicates a failure in the PEM.

The following conditions must exist for an AC PEM to operate normally:

- The PEM is fully seated in its bay and the ejector levers are secured.
- AC-input power is within the required range is correctly connected to PEMs.
- The power switch on the PEM is switched on.
- The green LEDs labeled OUTPUT OK and INPUT OK on the PEM are on.

To help isolate a problem with an AC-input power supply, follow these steps:

Step 1 If the OUTPUT OK LED is off, verify that the power supply is fully seated in its bay, the ejector levers are flush with the power supply faceplate, and the captive screws are secured.

- If the OUTPUT OK LED is on, go to Step 6.
- If the OUTPUT OK LED remains off, go to Step 2

Step 2 Check the AC power source.

- Check the AC power cord from the power source to the router.
 - Verify that the power cord is seated securely in the PDU and the AC outlet.
 - Verify that the power cord is not worn or damaged. If the insulation appears cracked or broken, or the plugs appear loose, replace the power cord with a new power cord.
- Verify that the AC power source circuit breaker is on and has not tripped, and that the circuit breaker has the proper current rating.

- Verify that each power supply in the router is attached to a separate AC power source.
- If the router is connected to an uninterruptable power supply (UPS), verify that the UPS is functioning correctly. Note that there might be a UPS for each power supply in the system.

If the AC power source wiring appears to be okay, but the power supply OUTPUT OK LED remains off, go to Step 3.

Step 3 Plug the power cord into a different, but compatible AC outlet.

- If the power supply OUTPUT OK LED is on, the original AC outlet is faulty and cannot be used. Notify the appropriate facilities personnel and go to Step 6.
- If the power supply OUTPUT OK LED remains off, go to Step 4.

Step 4 Exchange the existing power cord for another power cord.

- If the power supply OUTPUT OK LED is on, the original power cord is faulty and must be replaced. The AC portion of the power supply is working normally, go to Step 6.
- If the OUTPUT OK LED still fails light when connected to a different power source with a new power cord, the power supply is probably faulty. Go to Step 5.

Step 5 If a spare power supply is available, replace the existing module with the spare and restart the system.

- If the OUTPUT OK LED on the spare power supply is on, the power supply is working normally, go to Step 6. The original power supply is faulty and should be returned for replacement.

Step 6 Is the power supply INPUT OK LED on?

- If yes, the power supply is functioning normally.



Note In a Cisco XR 12406 router with two power supplies, the output power from the second power supply is adequate to maintain router operation.

- If no, and there is no other system activity (fan assembly is off; line cards are not powered), the power supply is faulty. Replace the power supply.

- If no, but the fan assembly is operating, suspect a faulty power supply INPUT OK LED. If the fan assembly is operating, all internal DC voltages are within tolerance. Use the **show environment** command to check the voltages on each card. The fan assembly uses -48 VDC.
-

If you are unable to resolve the problem or if you determine that either the power supply or power cable is faulty, contact a service representative for assistance.

Troubleshooting the DC Power Subsystem

The DC PEMs and PDUs provide DC power to the router which is distributed to the card circuitry.

Begin checking the power subsystem by first looking at the three LEDs on the PEM. The INPUT OK LED on an DC PEM is on when DC power is applied, The OUTPUT OK LED is on when the power switch is turned on.

- The amber OUTPUT FAIL LED is normally off, but comes on if the PEM detects a fault.
- The DC PEMs are monitored by the MBus module and the RP for over-or-under voltage and current conditions.

Figure 4-2 shows the location of the LEDs on the PEM.

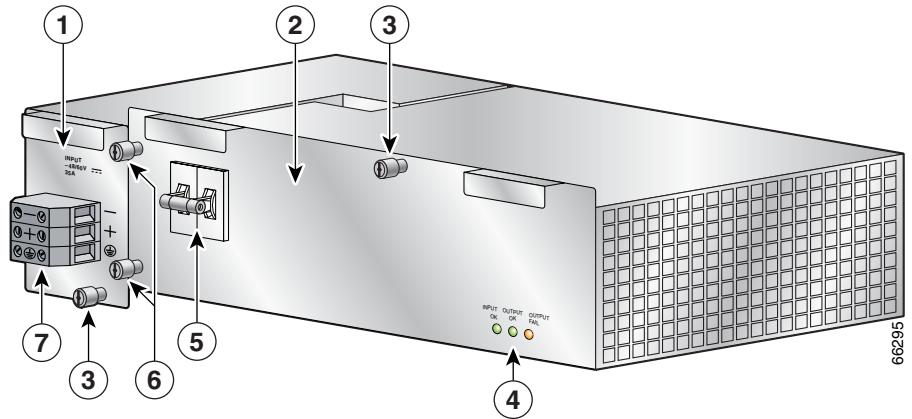
Figure 4-2 DC PEM and PDU

1	DC PDU	5	On/Off switch
2	DC PEM	6	PDU captive screws
3	PEM captive screws	7	Terminal Block
4	LEDs		

Table 4-2 summarizes the function of these indicators.

Table 4-2 DC-Input PEM LED Indicators

LED Label	Color	Function
OUTPUT OK	Green	PEM is operating normally in a powered-on condition.
INPUT OK	Green	DC power is present at the PEM input and within the specified limits.
OUTPUT FAIL	Amber	Indicates a failure in the PEM.

The following conditions must exist for a DC PEM to operate normally:

- The PEM is fully seated in its bay and the ejector levers are secured.
- DC-input power is within the required range and is correctly connected to the chassis PDU terminal connector block.
- The circuit breaker on the PEM is switched on.
- The green LEDs labeled OUTPUT OK and INPUT OK are on, and the amber LED labeled OUTPUT FAIL is off.

Follow these steps to help isolate a problem with a DC PEM:

-
- Step 1** Is the OUTPUT FAIL LED on?
- If yes, the PEM is faulty. Replace the PEM.
 - If no, go to Step 2.
- Step 2** If the INPUT OK LED is off, verify that the PEM is fully seated in its bay, the ejector levers are flush with the PEM faceplate, and the captive screws are secured.
- If the INPUT OK LED comes on, go to Step 6.
 - If the INPUT OK LED remains off, go to Step 3.
- Step 3** Verify that the PEM circuit breaker switch is on.
- If yes, go to Step 4.
 - If no, switch the circuit breaker on.
 - If the INPUT OK LED remains off, go to Step 4.
 - If the INPUT OK LED comes on, go to Step 6.

- Step 4** Power off the PEM circuit breaker switch and check the DC power source:
- Check the DC power wires from the power source to the router.
 - Verify that the power wires are fastened securely at the PDU and the DC source.
 - Verify that the power wires are not worn or damaged. If the insulation appears cracked or broken, have the power wires replaced.
 - Make sure that the DC power source circuit breaker is on, and that the circuit breaker has the proper current rating.
 - Verify that each PEM in the router is attached to a separate DC power source.
 - Power on the PEM circuit breaker.
 - If the PEM INPUT OK LED comes on, go to Step 6.
 - If the PEM INPUT OK LED remains off, go to Step 5.
- Step 5** Remove the PEM and insert it in the second bay in the router, or into a bay on another Cisco XR 12404 router.
- If the INPUT OK LED remains off, the PEM is faulty and needs to be replaced.
 - If the INPUT OK LED comes on, the input portion of the PEM is working normally, go to Step 6.
- Step 6** Is the OUTPUT OK LED on?
- If yes, the power source is good and the PEM is operating normally.



Note In a Cisco XR 12404 router with two power supplies, the output power from the second power supply is adequate to maintain router operation.

- If no, and there is no other system activity (fan assembly is off; line cards are not powered), the PEM is faulty. Replace the PEM.
 - If no, but the fan assembly is operating, suspect a faulty OUTPUT OK LED. If the fan assembly is operating, all internal DC voltages are within tolerance. Use the **show environment** command to check the voltages on each card. The blower module uses –48 VDC.
-

If you are unable to resolve the problem or if you determine that either the PEM or power wiring is faulty, contact a service representative for assistance.

Troubleshooting the Processor Subsystem

The Cisco XR 12404 router processor subsystem consists of the RP, the line cards, and the CSF card. The system cannot operate unless the RP is installed. The RP and the line cards each have two processors. One processor is the main processor; and the other processor is a component in the MBus module.

- The MBus module begins operation as soon as power is applied to the system. The MBus module determines the type of card it is mounted on and whether it should turn on the DC-DC converter.
- The RP MBus module turns on card power after a brief delay; the line card MBus modules delay turning on power until they receive a command from the RP.

A Cisco XR 12404 router requires that one RP be installed, or the system cannot operate. A line card that is partially connected to the backplane can send incomplete signals to the RP, which could cause the system to hang. If necessary, you can troubleshoot individual line cards, but first make sure that the RP is installed properly and the system software has initialized successfully.



Note

The primary RP must be installed in Slot0 which is a narrow slot. If a redundant RP is installed in another slot, a narrow card filler panel must be used to ensure proper air flow through the chassis and electromagnetic compatibility (EMC).

A power-on self-test (POST) runs immediately at power-on to determine the condition of the RP memory. Results are displayed in the alphanumeric LED display as a pass/fail message.

Troubleshooting the RP

When the router is powered on, the alphanumeric display on the RP indicate the following (Figure 4-3):

- Upper row—Indicates which RP software component is running. At the end of a successful boot process, this display reads MSTR.
- Lower row—Indicates the current phase of the boot process. At the end of a successful boot process, this display reads PRP.

Figure 4-3 RP Alphanumeric Display

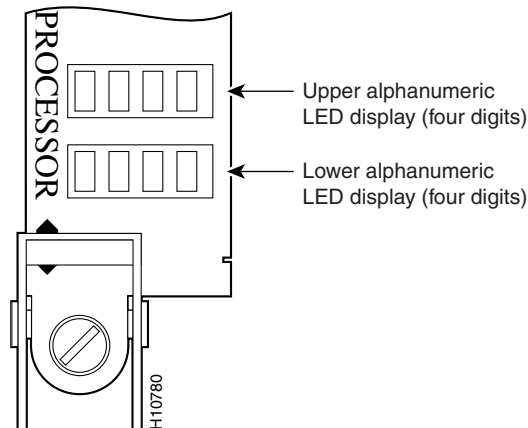

Troubleshooting Using the RP Alphanumeric Display

You can use the alphanumeric display to isolate a problem with the RP. The two rows on the alphanumeric display are powered separately:

- The upper row receives power from the DC-to-DC converters on the RP.
- The lower row is powered directly from the MBus on the RP through the chassis backplane.
 - If the lower row is not operating, the MBus module may be malfunctioning.
 - If the MBus module is operating, the lower row could be on even if the RP failed to power on.
- If neither the upper nor the lower row is on, but the power modules and the blower modules are operational, the RP may not be installed properly, or the +5 VDC output from the chassis backplane is faulty.
 - Make sure that the system is powered on.
 - Initialize the RP by ejecting it from the chassis backplane and then reseating it.



Caution

The soft reset (NMI) switch is *not* a mechanism for resetting the RP and reloading the Cisco IOS image. It is intended for software development use. To prevent system problems or loss of data, use the soft reset switch *only* when instructed by a Cisco certified service representative.

- If both the upper and the lower displays are operating, check the meaning of the messages (see Table 4-3).

When the DC-to-DC converters are powered-on by the MBus module, the RP processor begins the boot process and displays various status messages. Some messages appear briefly; while others appear for several seconds. If the messages appear to stop at a particular point, the boot process may be halted.

- Make a note of the message.
- Turn off power to the router, then turn on the power again to reset the router and start the boot process. If the router halts again, replace the RP.

Table 4-3 *Troubleshooting Using the RP Alphanumeric Display Messages*

Message	Description
LMEM TEST	Running low memory test
LCAH TEST	Initializing lower 15K cache
BSS INIT	Initializing main memory for ROM
NVRAM INIT	Initializing NVRAM
EXPT INIT	Initializing interrupt handlers
TLB INIT	Initializing TLB
CACH INIT	Initializing CPU data and instruction cache
CACH PARY	Enabling CPU cache parity
MEM INIT	Initializing main memory
NVRAM SIZE	Detecting the NVRAM size
PCMC INIT	Initializing the PCMCIA
EXIT INIT	Exiting the initialization sequence
IOS UP	Running Cisco XR IOS software

The RP has 8 device or port LED activity indicators that show the status of the Ethernet connections (Figure 4-4).

Figure 4-4 RP LEDs

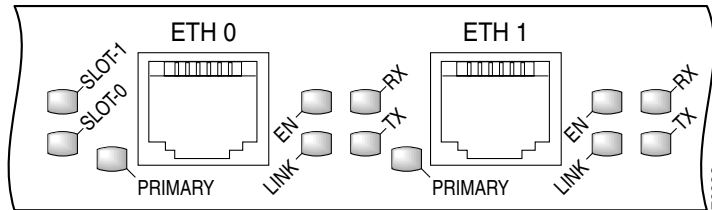

LINK	Indicates link activity
EN	Indicates the port is enabled
TX	Indicates data transmission
RX	Indicates data reception

The RJ-45 port LEDs on the RP indicate:

- Which Flash memory card slot is active.
 - Each LED lights when its corresponding PCMCIA slot is accessed (SLOT 0 and SLOT 1).
- Which Ethernet connection is in use.
 - 4 RJ-45 Ethernet port activity LEDs indicate link activity (LINK), port enabled (EN), data transmission (TX), and data reception (RX).
- What is occurring on the Ethernet interface.
 - 2 Ethernet port-selection LEDs (labeled PRIMARY) identify which of the Ethernet connections are selected. Because both ports are supported on the RP, the LED on port ETH0 is always on. The LED on port ETH1 lights when it is selected.

Check the following to help isolate a problem with the RP.

- Are both alphanumeric LED displays on?
 - The two displays are powered separately. The left display receives power from the DC-DC converter on the RP. The right display is powered directly from the power supply; therefore, even if the RP has not powered up, its right display could be on. If both displays are off, the RP may not be properly seated in the backplane connector, there might be a problem with the MBus module on the RP, or the system power supply might be off.
- If both displays are on, check the message being displayed. As soon as the DC-DC converter is turned on by the MBus module, the processor on the RP begins the boot process. Status messages are displayed as the boot process continues. If one of the messages appears frozen, the boot process could be halted. Write the message being displayed on a piece of paper. Turn off the PEM power switches, then turn them back on to reset the system and start the boot process again. If the system halts again, the RP could be faulty and may need to be replaced.
 - If the PEMs and fans appear operational but none of the RP LEDs or displays are on, suspect that the RP has not been properly installed or that the +5 VDC output from the CSF card is faulty.
 - Turn the PEM power switch to the OFF position on each PEM.
 - Loosen the two captive screws on the left and right sides of the RP faceplate, and use the ejector levers to eject and reseal the RP. Tighten the captive screws, then power on the system by turning the PEM power switches on.
- Is a Critical, Major, or Minor alarm LED on the CSF card on?
 - If any of the three CSF card LEDs is on, a fault has been detected in the system. Check the console for messages indicating the source of the problem.
 - There could be a false error indication originating from the RP. You may want to reseal or replace the RP.



Caution

The RP reset switch resets the RP and the entire system. To prevent system errors and problems, use it only at the direction of a Cisco-certified service representative.

Troubleshooting the Line Cards

As each line card powers on, a power-on self-test (POST) is performed on the line card memory. A full set of field diagnostics can also be run on a line card from the system console providing a pass/fail message both in the line card alphanumeric LED display and on the system console.

Check the following to help isolate a problem with the line cards:

- Are both banks of alphanumeric LED displays on?
 - The two displays are powered separately. The left display receives power from the DC-DC converter on the line card. The right display is powered directly from the power supply. So, even if the line card has not powered up, the right display could be on. If both displays are off, the line card might not be fully plugged into the backplane connector, there might be a problem with the MBus module on the line card, or the system power supply may be off.
 - If both displays are on, check the message being displayed. As soon as the DC-DC converter is turned on by the MBus module, the processor on the line card begins the boot process. Status messages are displayed in the alphanumeric displays as the boot process continues on the line card.

The system attempts to boot identical line cards in parallel. Further, the system boots line cards as soon as they are powered on and become available for backup.

During the line card boot process, which occurs immediately after the RP boot process, you can observe the alphanumeric LED displays on each line card. For additional information about the displays and definitions, see the Cisco IOS XR Troubleshooting Guide (see “Obtaining Documentation, Obtaining Support, and Security Guidelines” section on page -xii).

Troubleshooting the Cooling Subsystem

The Cisco XR 12404 router has a fan tray assembly located on the left side of the chassis when you are facing the front of the chassis. The fan tray assembly provides cooling air for the router components. The fan tray assembly receives power and signals through a connector mounted on the fan tray, which mates with a connector mounted on the backplane.

The fan tray assembly contains:

- 7 fans
- 2 controller cards
- 1 connector

Check the following to help isolate a problem with the cooling system:

- Do the fans come on?



Note In noisy environments listen for the fans. Place your hand at the left side of the chassis beside the fan tray assembly to feel for air being forced out the exhaust vents.

- If the fans come on, the –48 VDC line from the power supply to the fan tray assembly is good.
- If the fans do not come on, there could be a problem with either the fan tray assembly or the –48 VDC power. Check the OUTPUT FAIL LED on each power supply. If the OUTPUT FAIL LED on a PEM is on, the PEM is faulty and should be replaced.
- If the fans do not come on and the PEM OUTPUT FAIL LED is off (–48 VDC is OK), ensure that the fan tray assembly is seated properly to the backplane connector.
 - Remove the fan tray assembly by loosening the two captive screws securing it to the chassis. Pull the assembly out a few inches and firmly push it back in to reseal it. Tighten the two captive screws.
- If the fans do not come on, there could be a problem with the fan tray assembly controller card.
- The following message on your console monitor, indicates that the system has detected an overtemperature condition or out-of-tolerance power inside your router.

```
Queued messages:
%ENVM-1-SHUTDOWN: Environmental Monitor
initiated shutdown
```

An overtemperature condition is unlikely at initial startup due to an environmental shutdown. As a precaution, ensure that heated exhaust air from other equipment is not entering the air filter, and that there is sufficient

clearance (at least 6 inches, 15.24 cm) around all sides of the chassis to allow cooling air to enter and hot air to exhaust. Should an overtemperature condition occur at initial startup:

- Check the condition of the air filter. If the air filter appears dirty, you should remove the air filter and replace it; or remove the air filter, take it away from the chassis, and vacuum the air filter.
- The overtemperature condition message could also indicate a faulty component or temperature sensor. Before the system shuts down, use the **show environment all** or **show environment table** commands to view the internal system environment including voltages and temperatures measured at each card.

If you are still unable to resolve the problem, contact a service representative for assistance.



CHAPTER 5

Maintaining the Router

This chapter contains safety at the field replaceable unit (FRU) level, removal and replacement instructions for FRUs and procedures to troubleshoot the FRUs.

Your Cisco XR 12404 router is equipped as ordered and is ready for installation and startup when it leaves the factory. After you install and configure the router, you may need to perform other procedures to ensure that the router continues to operate properly. Also, as your networking requirements change, you may need to upgrade your system by adding or changing components.

Before performing the procedures in this chapter, be sure to review the safety information in the “Laser Safety” section on page 2-6, and the “Lifting Guidelines” section on page 2-6.

You should also be familiar with the *Regulatory Compliance and Safety Information for the Cisco 12000 Series Router* document (78-4347-xx) that came with the router.



Caution

All procedures in this chapter assume that you are wearing an ESD-preventative wrist strap. Refer to “Preventing Electrostatic Discharge Damage” section on page 2-4 for additional information.

The following sections describe tools and procedures necessary to maintain the Cisco XR 12404 router.

- Tools and Equipment, page 5-2
- Powering Off the Router, page 5-3
- Removing and Installing the Front Cover, page 5-4

- Removing and Replacing the Air Filter, page 5-7
- Removing and Replacing the Fan Tray Assembly, page 5-10
- Removing and Replacing an AC Power Entry Module, page 5-13
- Removing and Replacing a DC Power Entry Module, page 5-17
- Removing and Replacing a DC PDU, page 5-21
- Removing and Replacing an RP or Line Card, page 5-29
- Removing and Replacing a Consolidated Switch Fabric Card, page 5-35
- Upgrading the RP and Line Card Memory, page 5-37

Tools and Equipment

The following section lists tools and equipment for unpacking, performing maintenance, and setting up your Cisco XR 12404 router.

- ESD-preventive strap
- 3/16-inch flat-blade screwdrivers
- 1/4-inch flat-blade screwdrivers
- 9/15-inch (14-mm) wrench
- 3/4-inch (19-mm) socket and ratchet wrench
- 2-mm allen wrench
- Vacuum cleaner
- Antistatic bag (or similar ESD-preventive container)
- Number 2 Phillips screwdriver

Powering Off the Router

Unless otherwise noted, the maintenance tasks described in this chapter can be performed while the router remains powered on. Most Cisco XR 12404 router field replaceable units (FRUs) support online insertion and removal (OIR), which means they can be removed and installed (hot-swapped) while the router remains powered on.

- Line cards and the fan tray assembly are hot-swappable.
- PEMs and RPs also support OIR, but are hot-swappable only when the system is equipped with two PEMs or two RPs, respectively.
- The power distribution unit (PDU) and CSF card do not support OIR.

Use the following procedure to power off an AC- or a DC-powered router.

-
- Step 1** Turn off the power switches (AC) or circuit breaker switches (DC) on the PEMs.
- Step 2** Turn off the facility circuit breakers for power source lines connected to the PDU.
- Step 3** When the procedure requires that the router be disconnected from source power:
- AC-powered systems—Unplug the AC power cords from the power outlets.
 - DC-powered systems—Disconnect and remove the source DC wires from the power connector blocks on the PDU.
- Step 4** Verify the following conditions:
- LEDs on the PEMs are off.
 - LEDs on the RP, all line cards, and CSF are off.
 - The fans in the fan module tray are off.

Removing and Installing the Front Cover

This section describes how to change the front cover to open from left-to-right by installing the hinge on the opposite side.

Use the following procedure to change the location of the hinge.

-
- Step 1** Open the front cover by pressing the right latch button (Figure 5-1).

Figure 5-1 Opening the Front Cover

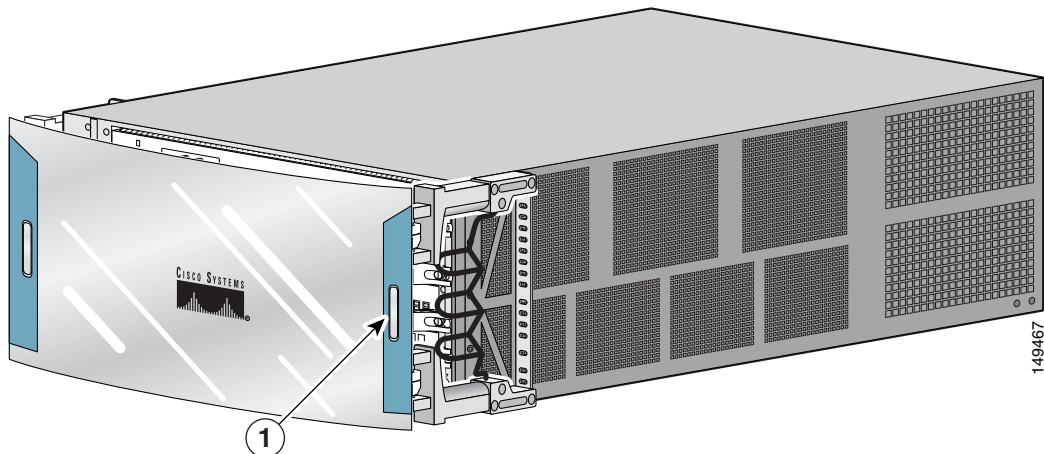

-
- 1** Front Cover Latch
-

- Step 2** Remove the front cover by lifting the (top and bottom) hinge pins to free the cover from the chassis (Figure 5-2).

**Caution**

Make sure you are holding the front cover securely so it does not drop when you release it from the chassis.

- Step 3** Reinstall the hinge pins into the chassis hinge brackets.

Figure 5-2 Removing or Installing Hinge Pins

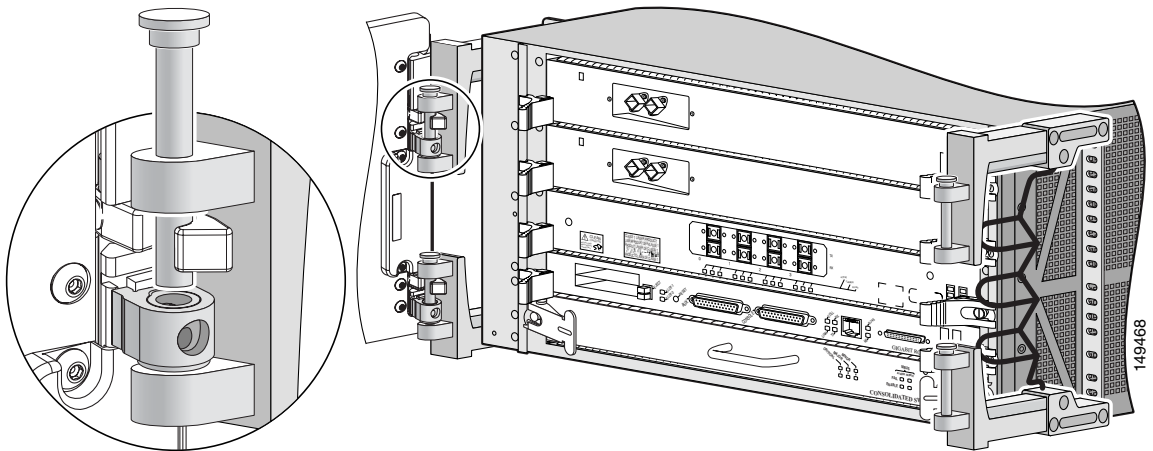

Step 4 Remove the bumpers and pivot blocks from the cover as shown in Figure 5-3.

Figure 5-3 Removing the Bumpers and Pivot Blocks

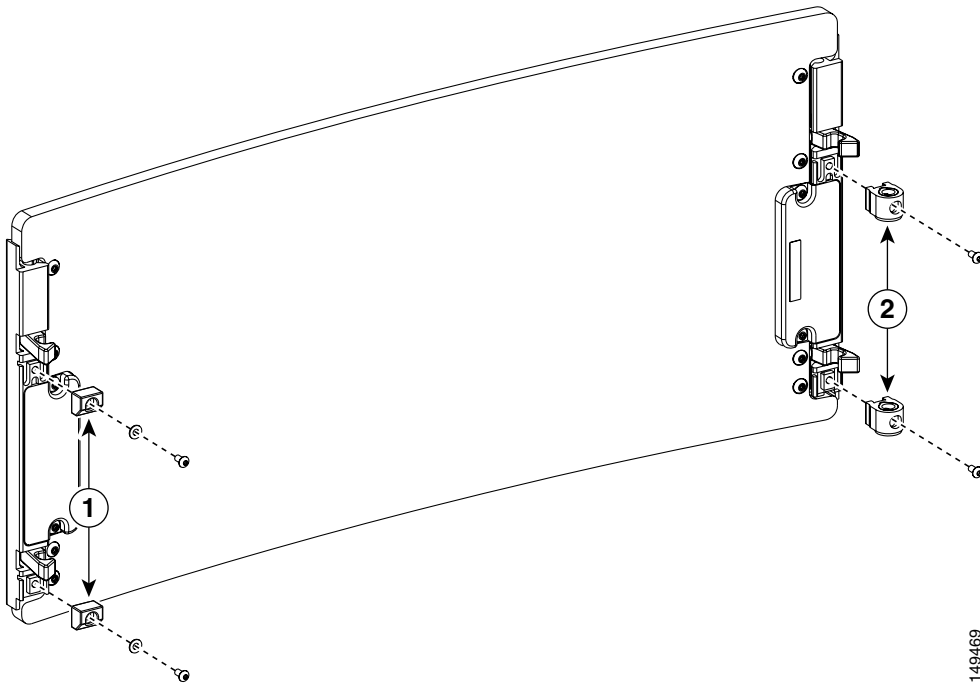

1	Bumpers	2	Pivot Blocks
---	---------	---	--------------

Step 5 Reinstall the hardware to the opposite sides of the front cover:

- a. Mount pivot blocks to the left side and tighten the screws until snug.
- b. Mount the bumpers to the right side and tighten the screws until snug.

- Step 6** Attach the front cover to the chassis:
- a. Remove the hinge pins from the hinges on the right side of the chassis.
 - b. Align the pivot blocks on the front cover with the hinges on the right side of the chassis and install the hinge pins to hold the cover in place (see Figure 5-2).
 - c. Close the front cover by pressing the latch button allowing the cover latch to engage with the hinge pins on the chassis.
-

Removing and Replacing the Air Filter

The Cisco XR 12404 router is equipped with a user-serviceable air filter that removes dust drawn into the router by the fan assembly tray. You should examine the air filter once a month (or more often in dusty environments). If the filter appears dirty, you can either vacuum or replace it. If the filter appears worn or torn, dispose of it in a responsible manner and install a replacement air filter.



Caution

A damaged air filter can restrict the airflow, cause an overtemperature condition in the router and degrade EMI performance.

Use the following procedure to clean or replace the air filters.

- Step 1** Grasp the small tab on the edge of the air filter and pull the tab to remove the air filter from the chassis (Figure 5-4).



Tip

If you are unable to lift the tab on the edge of the air filter, use a flat-blade screwdriver to lift the tab, then grasp it.

Figure 5-4 Cisco XR 12404 router Air Filter Location

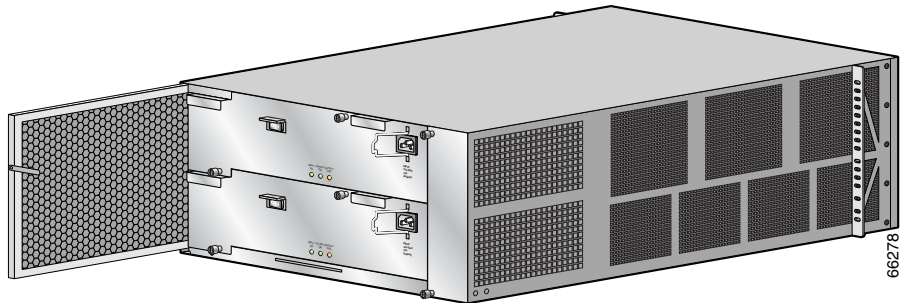

- Step 2** Visually check the condition of the air filter.
- If the filter appears dirty, you can either vacuum or replace it.



Caution

Do not vacuum the air filter while it is installed in the housing.

- If the filter appears worn or torn, dispose of it in a responsible manner and install a replacement air filter.

- Step 3** Reinstall the air filter into the chassis noting the direction of the airflow arrows on the top of the air filter frame (Figure 5-5).

**Caution**

The arrows located on the edge of each air filter frame that indicate the direction of *air flow*. Always install the air filter with the arrow pointing in toward the RP and line card cage.

Figure 5-5 Cisco XR 12404 router Air Filter Direction of Air Flow

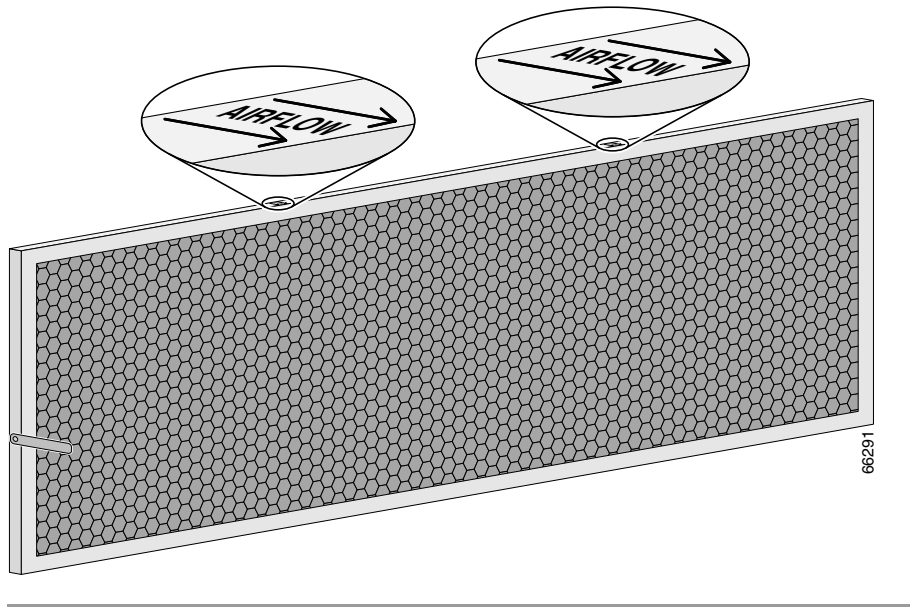

66291

Removing and Replacing the Fan Tray Assembly

Use the following procedure to remove and replace the fan tray assembly.



Caution

Although the fan tray assembly supports OIR and can be replaced without interruption to system operation, do not operate the system without the fan tray assembly for more than a few minutes to prevent overheating.

Step 1

Loosen the two captive screws on the fan tray assembly (item 3 in Figure 5-6).

Figure 5-6 Cisco XR 12404 router Fan Tray Assembly Location

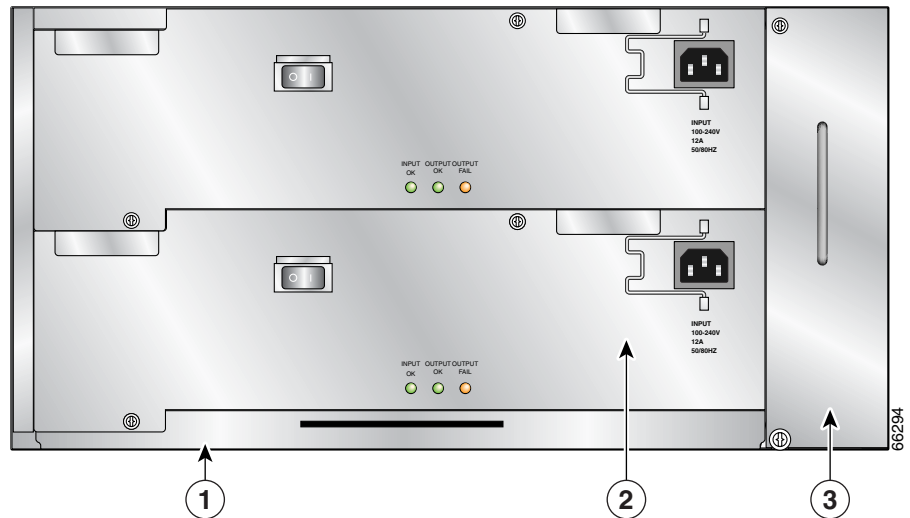

1	Chassis	3	Fan tray assembly
2	AC PEM		

- Step 2** Grasp the handle and pull the fan tray assembly out of the chassis (Figure 5-7).
- Support the bottom of the assembly with your other hand when removing the fan tray.
 - Electrical connection for the fans are automatically disconnected when the fan tray is removed from the housing.

Figure 5-7 Cisco XR 12404 router Fan Tray Assembly

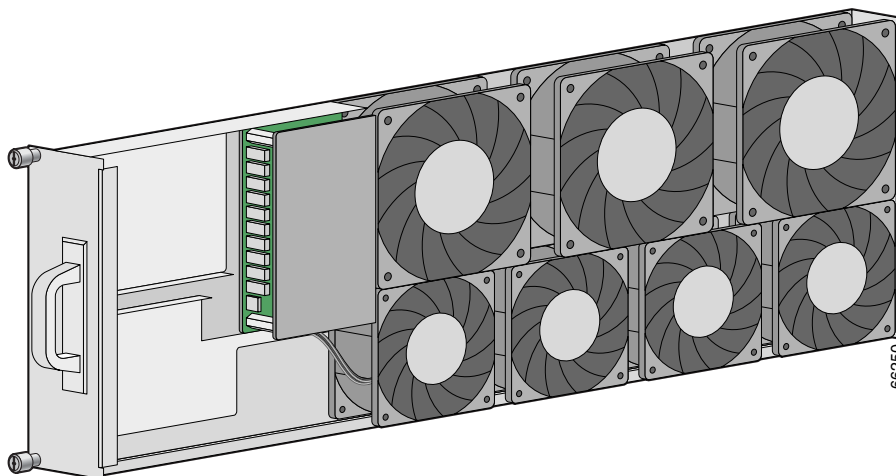

- Step 3** Hold the replacement fan tray assembly with both hands and insert the connector end of the fan tray into the chassis.



Caution The fan tray is designed to install only one way. Do not use excessive force when installing the fan tray assembly.

- Step 4** Tighten the two captive screws on the fan tray assembly.
- See the “Troubleshooting the Fan Tray Assembly Installation” section on page 5-12 if the fan tray assembly is not operating properly after installation.

Troubleshooting the Fan Tray Assembly Installation

Use the following procedure to troubleshoot the fan tray assembly if it is not operating properly after installation.

**Caution**

To prevent overheating, do not operate the system without the fan tray assembly operational for more than a few minutes.

-
- Step 1** Make sure the router is powered on and that all power cords are connected properly.
- Step 2** Loosen the captive screws and reseal the fan tray assembly.
- Tighten the captive screws to secure the fan tray assembly to the chassis.
- Step 3** If after several attempts to reseal the fan tray assembly, replace the existing fan tray assembly with a spare.
- If the spare fan tray assembly also fails, power off the router and contact a Cisco service representative for assistance.
-

Removing and Replacing an AC Power Entry Module

Although an AC PEM supports OIR, in order to maintain operational redundancy, proper cooling, and meet EMI compliance standards, you must have both working power supplies installed. When you remove a failed power supply with the router in operation, perform the replacement as quickly as possible. Make sure you have the tools and the replacement power supply ready before beginning the removal and installation procedure.

Refer to Figure 5-8 and use the following procedure to remove and replace an AC PEM.

-
- Step 1** Power off the faulty PEM.
 - Step 2** Unplug the power supply cord from its AC outlet.
 - Step 3** Power off the circuit breaker assigned to that AC outlet.
 - Step 4** Release the bail latch and unplug the power cord from its receptacle.
 - Step 5** Loosen the two captive screws that secure the PEM to the chassis.
 - Step 6** Remove the PEM from the chassis using the finger grips to pull it out.

**Warning**

An AC PEM weighs approximately 11.0 lbs. (4.98 kg.). Use both hands to remove it from the chassis.

Figure 5-8 AC PEM Components

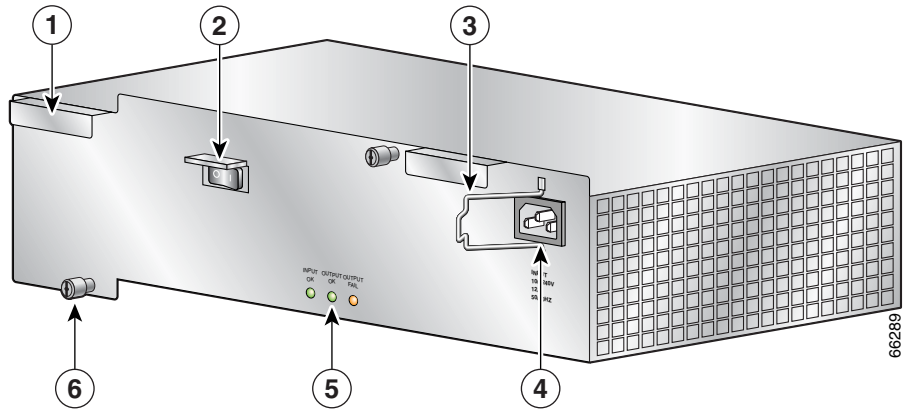

1	AC PEM finger grips	4	Power cord receptacle
2	On/Off switch	5	Status LEDs
3	Bail latch	6	Captive screws

**Tip**

If you plan to return the defective PEM to the factory, repackage it in the shipping container you received with the replacement PEM.

Step 7 Slide the replacement PEM into the bay until it is seated to the backplane connector.

**Note**

Make sure the power switch is in the off (0) position.

Step 8 Tighten the two captive screws to secure the PEM to the chassis.
Electrical connections between the PEM the backplane connector are made automatically when the PEM is fully seated and the captive screws are tightened.

Step 9 Connect the power cord into the receptacle and place the bail latch over the power cord to secure it in place.

Step 10 Plug the power cord into its AC outlet.

Step 11 Power on the circuit breaker assigned to that AC outlet.

Step 12 Power on the PEM.

- The green Input OK and Output OK LEDs should be on.
- The amber Output Fail LED should be off.

See the “Troubleshooting an AC PEM Installation” section on page 5-15 if the PEM does not power on correctly.

Troubleshooting an AC PEM Installation

Refer to Figure 5-9 and use the following procedure to troubleshoot the PEM installation.

Figure 5-9 AC PEM Status LEDs

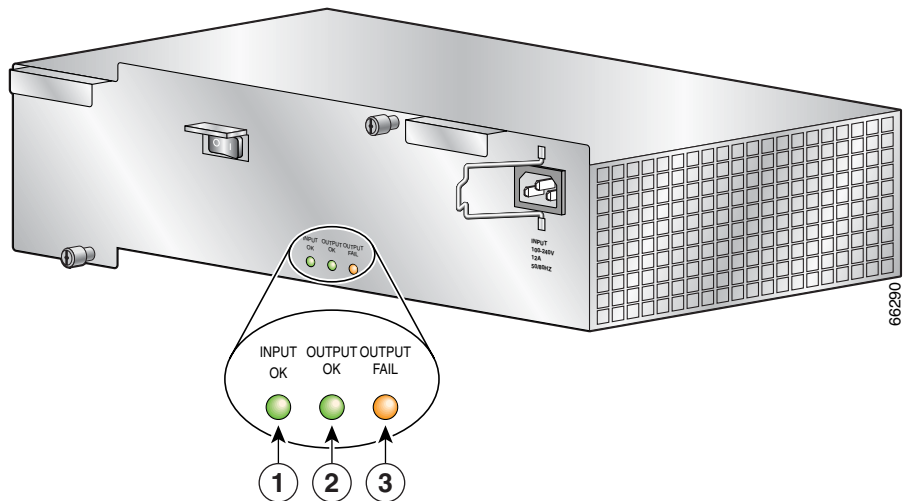

1	Input OK	Green On	The PEM is powered on and operating correctly.
2	Output OK	Green On	The AC power source is present and operating within the specified limit.
3	Output Fail	Amber On	The PEM detects a fault condition causing it to shutdown.

-
- Step 1** If the Input OK and Output OK LEDs are off, or if the Output Fail LED is on, make sure that the:
- PEM is firmly seated in the bay and the captive screws are tightened securely.
 - AC power source circuit breaker is switched on.
 - Power cord is firmly plugged into the AC power source receptacle.
 - Power cord is firmly plugged into the PEM and the bail latch is secure over the plug.
 - Power switch is set to the on (1) position.
- Step 2** If the problem still exists after checking the items in Step 1, replace the PEM. If replacing the PEM does not correct the problem, contact a Cisco service representative for assistance.
-

Removing and Replacing a DC Power Entry Module

Although a DC PEM supports OIR, in order to maintain operational redundancy, proper cooling, and meet EMI compliance standards, you must have both working power supplies installed. When you remove a failed power supply with the router in operation, perform the replacement as quickly as possible. Make sure you have the tools and the replacement power supply ready before beginning the removal and installation procedure.

Refer to Figure 5-10 and use the following procedure to remove and replace a DC PEM.

-
- Step 1** Power off the faulty PEM.
- Step 2** Power off the circuit breaker assigned to the DC power source.
- Step 3** Loosen the three captive screws that secure the PEM to the chassis.

Removing and Replacing a DC Power Entry Module

Step 4 Remove the PEM from the chassis using the finger grips to pull it out.



Warning

A DC PEM weighs approximately 11.0 lbs. (4.98 kg.). Use both hands to remove it from the chassis.

Figure 5-10 DC PEM and PDU Components

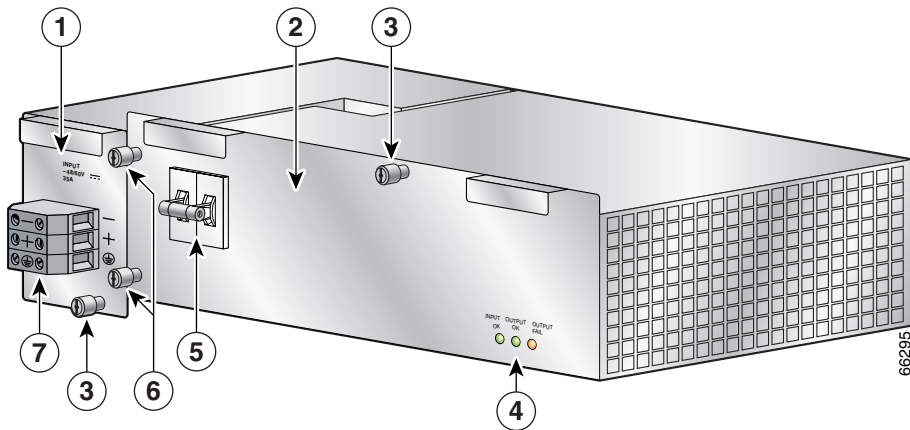

1	DC PDU	5	On/Off switch
2	DC PEM	6	PDU captive screws
3	PEM captive screws	7	PDU terminal block
4	Status LEDs		



Tip

If you plan to return the defective PEM to the factory, repackage it in the shipping container you received with the replacement PEM.

Step 5 Slide the replacement PEM into the bay until it is seated to the backplane connector.

- Make sure the power switch is in the off (0) position.

Step 6 Tighten the three captive screws to secure the PEM to the chassis.

Electrical connections between the PEM the backplane connector are made automatically when the PEM is fully seated and the captive screws are tightened.

Step 7 Power on the circuit breaker assigned to the DC source power.

Step 8 Power on the PEM.

- The green Input OK and Output OK LEDs are on.
- The amber Output Fail LED is off.

See the “Troubleshooting the DC PEM Installation” section on page 5-20 if the PEM does not power on correctly.

Troubleshooting the DC PEM Installation

Refer to Figure 5-11 and use the following procedure to troubleshoot the PEM installation.

Figure 5-11 DC PEM Status LEDs

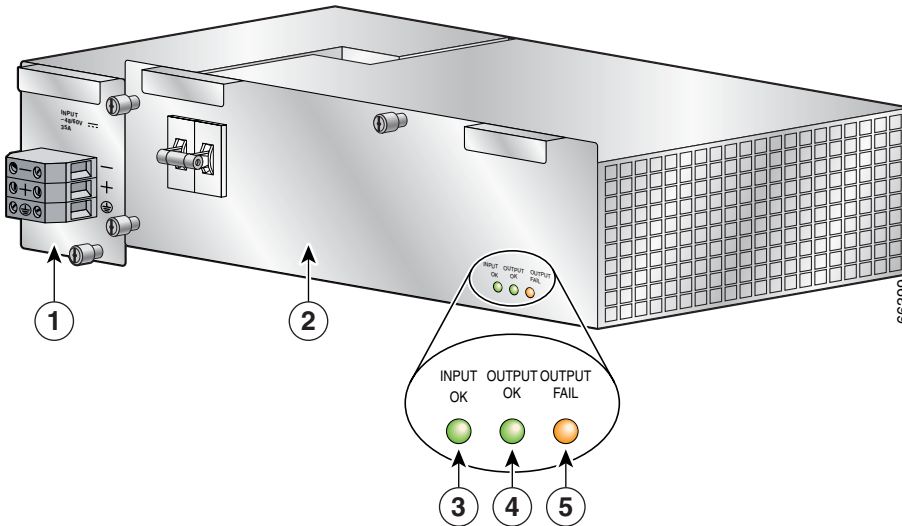

1	DC PDU		
2	DC PEM		
3	Input OK (Green)	On	DC PEM is operating normally in a power-on condition
4	Output OK (Green)	On	DC power source is present and within specified limit
5	Output Fail (Amber)	On	PEM is operating in a fault condition and shutdown has occurred

-
- Step 1** Make sure the power supply is seated properly:
- Eject and reseat the power supply. Make sure that the:
 - Captive screw on the ejector lever are tightened securely.
 - Power switch is set to the on (1) position.
- Step 2** If the Input OK and Output OK LEDs are off, or if the Output Fail LED is on, make sure that the:
- Power switch is set to the on (1) position.
 - Power leads are securely connected to the power connector block on the PDU.
 - Power cables are securely connected at the DC source connection.
 - The source DC circuit breaker is turned on.
- Step 3** If the problem still exists, replace the PEM.
- If replacing the PEM does not correct the problem, contact a Cisco service representative for assistance.
-

Removing and Replacing a DC PDU

The DC PDU does *not* support online insertion and removal (OIR) and cannot be replaced while the system is operating. You must power off the router before replacing the PDU.



Caution

To remove and replace the DC PDU, the system must be powered off. Notify the network administrator and other appropriate personnel that all routing traffic stops while the PDU is replaced.

Use the following procedure to remove and replace a DC PDU.

Removing and Replacing a DC PDU

Step 1 Power off *both* PEMs (item 5 in Figure 5-12).

Figure 5-12 DC PEM and PDU Components

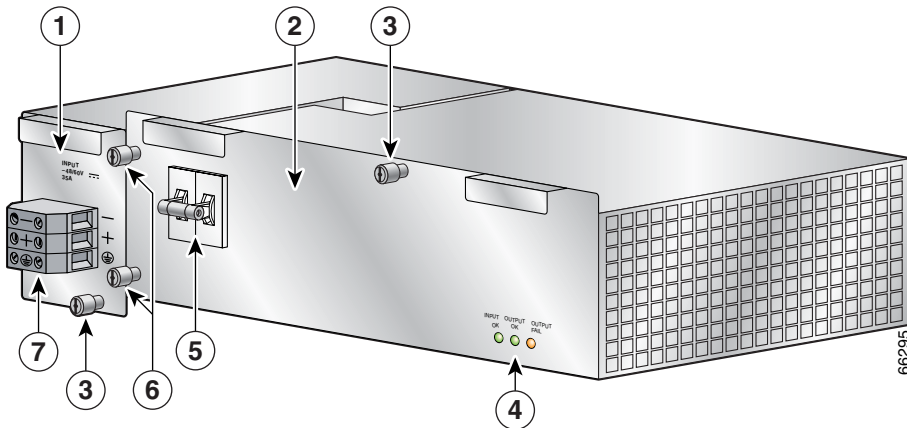

1	DC PDU	5	On/Off switch
2	DC PEM	6	PDU captive screws
3	PEM captive screws	7	PDU terminal block
4	Status LEDs		

Step 2 Power off the circuit breakers assigned to the DC power source.

- Step 3** Loosen the terminal block screws to disconnect the positive, negative, and ground wires from the DC PDU terminal block of the faulty PEM (Figure 5-13).

**Warning**

To prevent injury and damage to the equipment, always remove the source DC power leads and ground from the power shelf terminals in the following order: (a) negative (-), (b) positive (+), (c) ground.

**Caution**

Before removing wires, be sure to note the color for each type of wire (positive, negative, and ground). Because there is no color code standard for source DC wiring, you must be sure which power wires are connected to the proper positive (+) and negative (-) terminal ports. Typically, green (or green and yellow) indicate a ground wire, while power wire leads may be labeled positive (+) or negative (-). Because this is not always the case, the safest way to indicate the polarity of a wire is to note its color and identify it as described in this procedure.

Figure 5-13 DC PDU Terminal Block

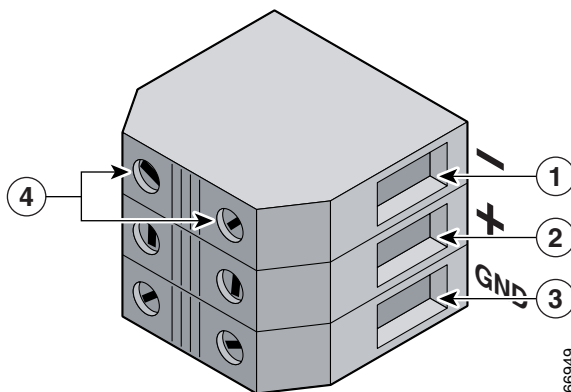

1	Negative port	3	Ground port
2	Positive port	4	Terminal port connector screws

Step 4 Loosen the captive screws securing the PDU and the PEM to the chassis (see item 6 in Figure 5-12).

Step 5 Remove the PDU/PEM from the chassis using the finger grips to pull it out.



Warning

A DC PEM and PDU weigh more than 11.0 lbs. (4.98 kg.). Use both hands to remove it from the chassis.

Step 6 Disconnect the PDU from the PEM.

Step 7 Connect the new PDU to the PEM (Figure 5-14).

Figure 5-14 Connector for DC PEM and DC PDU—DC PEM Rear View

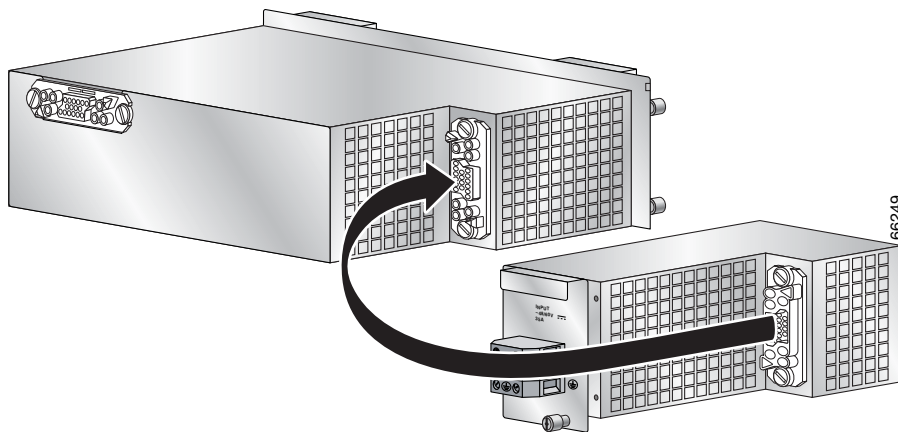

Step 8 Slide the PDU/PEM into the bay until the PEM is seated to the backplane connector. Make sure the power switch is in the off (0) position.

Step 9 Tighten the captive screws to secure the PDU and PEM to the chassis.

Electrical connections between the PEM the backplane connector are made automatically when the PEM is fully seated and the captive screws are tightened.

- Step 10** Connect the ground, positive, and negative wires to the PDU terminal block in the following order (Figure 5-15):
- Ground lead to the bottom port.
 - Positive lead to the middle port.
 - Negative lead to the top port.
 - Repeat these steps for the second power connector block.

**Warning**

To prevent injury and damage to the equipment, always attach the ground and source DC power leads to the power block connector in the following order: (a) ground to ground, (b) positive (+) to positive (+), (c) negative (-) to negative (-).

**Caution**

Be sure to connect the wires according to the color coding notes and labels you made in Step 3.

Figure 5-15 DC PDU Terminal Block

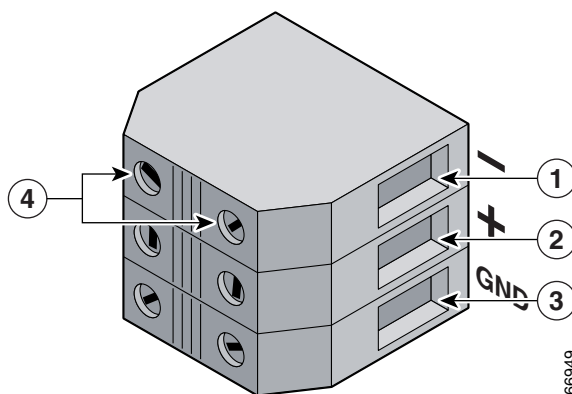

1	Negative port	3	Ground port
2	Positive port	4	Terminal port connector screws

Step 11 Power on the circuit breakers assigned to the DC power source.

Step 12 Power on *both* PEMs.

- The green Input OK and Output OK LEDs should be on.
- The amber Output Fail LED should be off.

See the “Troubleshooting the DC PDU Installation” section on page 5-27 if the PEM does not power on correctly.

Troubleshooting the DC PDU Installation

Refer to Figure 5-16 and use the following procedure to troubleshoot the PDU installation.

Figure 5-16 DC PDU, PEM, and Status LEDs

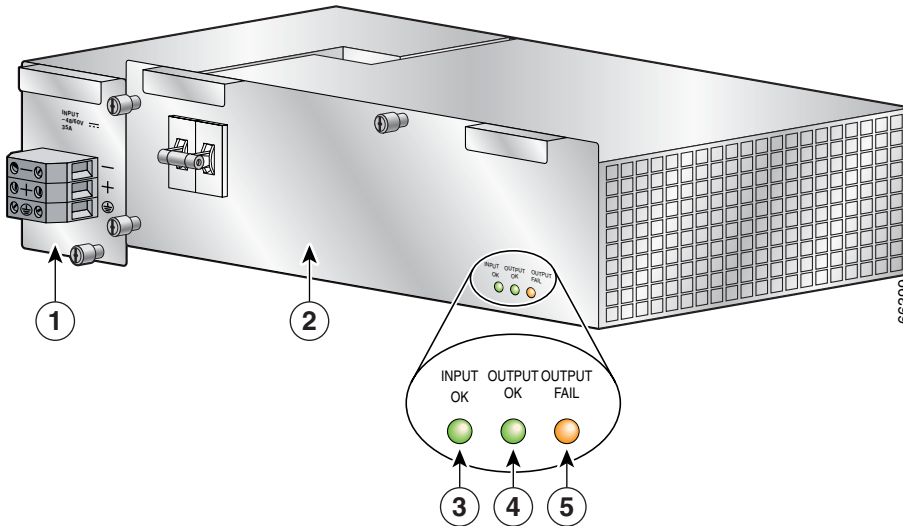

1	DC PDU		
2	DC PEM		
3	Input OK (Green)	On	DC PEM is operating normally in a power-on condition
4	Output OK (Green)	On	DC power source is present and within specified limit
5	Output Fail (Amber)	On	PEM is operating in a fault condition and shutdown has occurred

-
- Step 1** If the Input OK and Output OK LEDs are off, or if the Output Fail LED is on, check that the:
- PEM is firmly seated in the bay and the captive screws are tightened securely.
 - DC power source circuit breakers are switched on.
 - DC power cables are securely attached to the PDU terminal block.
 - Power switch is set to the on (1) position.
- Step 2** If the problem still exists after checking the items in Step 1, replace the PEM.
- Step 3** If replacing the PEM does not correct the problem, contact a Cisco service representative for assistance.
-

Removing and Replacing an RP or Line Card

Line cards can occupy any slot, zero (0) through 3 in the RP and line card cage. The Cisco XR 12404 router is configured with the RP in slot 0 (Figure 5-17). Redundant RPs can be placed in any slot, but requires a line card spacer to comply with EMI emission standards.



Note

Installing a card in slot 1 when all other slots are filled may require additional effort to properly seat the card. Because of the tight fit you have to either apply extra pressure to properly seat the card, or you can remove the card in slot 2 before installing the card in slot 1. After you install the card in slot 1 you can reinstall the card in slot 2.

Cisco XR 12404 router line cards support OIR, so they can be removed and installed while the router remains powered on. RPs also support OIR, but are hot-swappable only when the system is equipped with two RPs.

Additional line card information can be found in the respective installation and configuration documentation for each type of line card.

Figure 5-17 CSF Location and RP and Line Card Slot Numbers

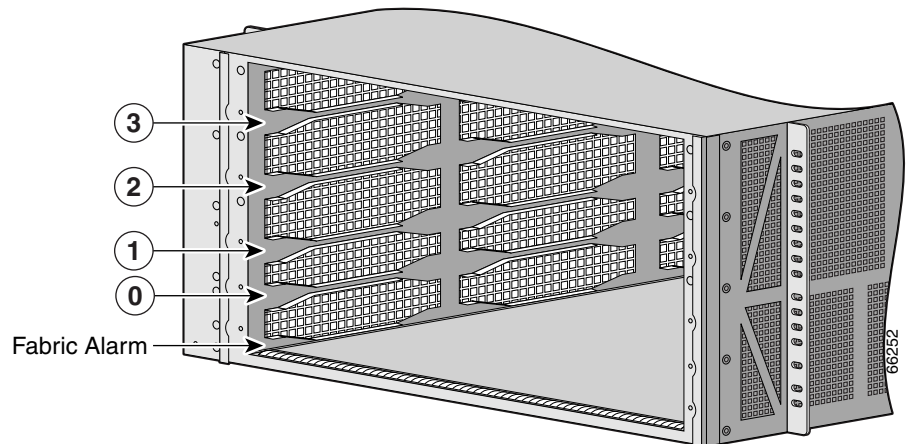

- Step 1** Identify the RP or line card to be replaced and write down the following information:
- The RP cable connections on the RP.
 - The number and type of RP or line card, so that you will know the location of the card when you re-install it or the replacement, in the card cage.
 - The network interface cable connection ports, on the RP or line card.
- Step 2** On RPs and line cards with multiple ports, start with the left port on the card and disconnect the interface cable connectors from each of the ports.
- Step 3** After all of the interface cables are disconnected, loosen the two captive screws on the cable-management bracket and pull the bracket away from the card.
- Step 4** Loosen the two ejector lever captive screws at each end of the card faceplate.
- Step 5** Simultaneously pivot the ejector levers away from each other to unseat the card from the backplane connector (Figure 5-18).

Figure 5-18 Removing an RP or Line Card from the Card Cage

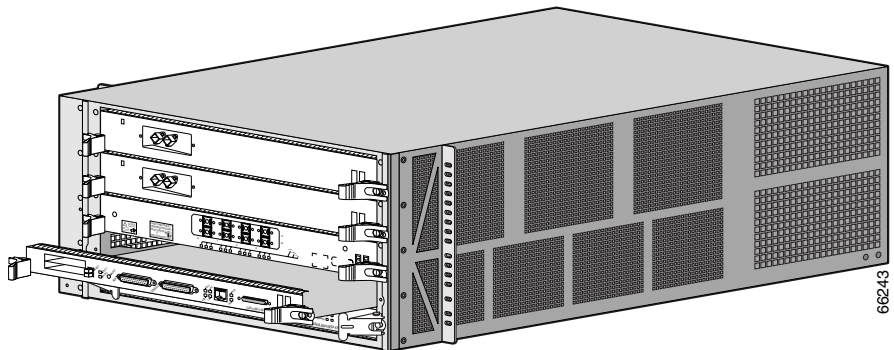

Step 6 Grasp the edges of the card carrier with both hand to support it and remove the card.



Caution Remove each RP or line card completely from the slots. A card left partially inserted into the slot can damage the EMI shielding on card in the slot directly below.

- Immediately place the RP or line card in an antistatic bag to protect it against ESD and to prevent dust from getting to the fiber-optic connectors on fiber-optic line cards.
- If you plan to return the defective unit to the factory, repackage it in the shipping container you received with the replacement RP or line card.

Step 7 Remove the RP or line card from its shipping package and antistatic bag.



Caution Handle the RPs and line cards by the metal card carrier edges only; avoid touching the board itself or any connector pins.

Step 8 Seat the RP or line card:

- a. Set both edges of the RP or line card into the card slot and partially slide the card into the chassis.
- b. Pivot the ejector levers away from each other by rotating each ejector lever outward away from the faceplate.
- c. Continue sliding the card into the slot until the ejector levers make contact with the front of the card cage, then *stop*.
- d. Seat the card by grasping each ejector levers and simultaneously pivot them toward the card faceplate.



Note The line card does not boot properly if not fully seated.

Step 9 Tighten the captive screws on the card.



Note The card captive screws must be tightened to meet EMI specification standards.

Repeat Step 1 through Step 9 for any additional replacement RPs or line cards, and then proceed to the next section.

Attaching the Cable-Management Bracket and Connecting Cables

The Cisco XR 12404 router line cards use cable-management brackets to:

- Organizing the network interface cables
- Keeping the network interface cables out of the way
- Positioning connectors at their respective ports on the line card faceplate
- Keeping the cables free of sharp bends (excessive bending in a network interface cable can cause performance degradation)

When you install a new RP or line card, you need to attach the line card cable-management bracket to the faceplate of the card before connecting the cables. The type of cable-management bracket used by a line card is determined by the card type and the number of network interface ports it has.

Use the following procedure to attach the cable-management bracket and cables to a line card.

Step 1 Orient the top of the cable-management bracket with the top of the line card faceplate (the end opposite the two four-character alphanumeric displays.)

Step 2 Align the two captive screws on the bracket with the threaded insert holes near the ejector levers on each end of the line card faceplate and finger-tighten the screws.

Step 3 Use a flat-blade screwdriver to secure the two captive screws.



Caution

Do not overtighten the captive screws; overtightening the screws can strip the threads on the screw or the insert in the faceplate.

Step 4 Repeat steps 1 through 3 for any remaining line cards.

Step 5 Attach an appropriate number of velcro straps through the slots in the cable-management bracket to support the network interface cables (Figure 5-19).

- a. Pull the small end of the velcro strap through the slot in the cable-management bracket.
- b. Insert the small end of the velcro strap into the slot in the wide end of the velcro strap.
- c. Pull the small end through the velcro strap slot to secure it to the cable-management bracket.

Figure 5-19 Line Card Cable-Management Brackets with Velcro Straps

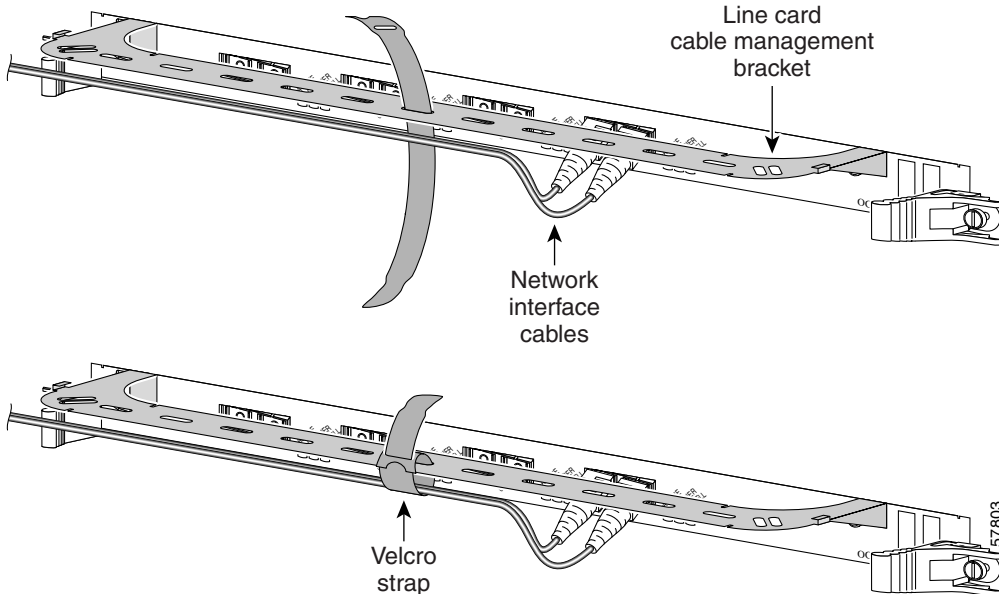

- Step 6** Proceeding from the left port on the line card to the right port (on line cards with multiple ports), identify the network interface cable for the line card port and insert the cable connector into the line card port (see Figure 5-19).
- a. Align the interface cable with the cable-management bracket.
 - b. Repeat for the remainder of the interface cables for this line card.



Note Carefully adjust the interface cables in the cable-management bracket to prevent any kinks or sharp bends in the interface cables. Kinks and sharp bends can destroy or degrade the ability of the optical fiber to propagate the signal-encoded beam of light accurately from one end of the cable to the other. Also, allow adequate strain relief in the interface cables.

- Step 7** Secure the interface cables to the cable-management bracket by wrapping the velcro straps around them (see Figure 5-19).



Note Do not wrap the velcro straps too tightly.

Removing and Replacing a Consolidated Switch Fabric Card

Use the following procedure to remove and replace a CSF card.

**Caution**

The CSF card is not hot-swappable component. You must shut down the router before removing the CSF.

- Step 1** Power off the router (see “Powering Off the Router” section on page 5-3).
- Step 2** Loosen the two captive screws on each side of the CSF card.
- Step 3** Grasp the card ejector levers and pivot them away from the CSF card faceplate (Figure 5-20).

Figure 5-20 *Installing a CSF Card*

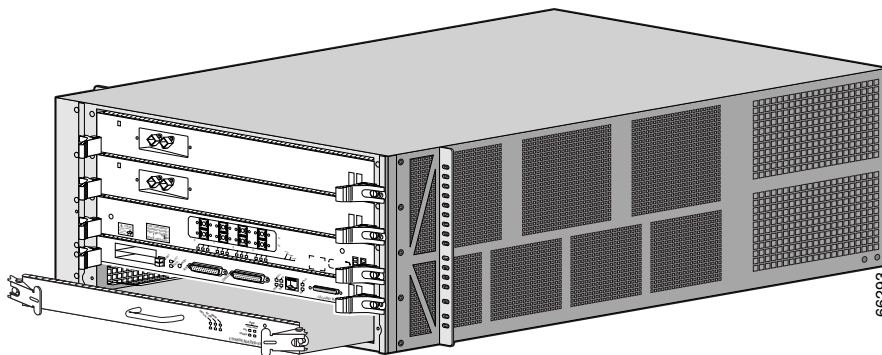

- Step 4** Slide the CSF half-way out of the slot, then *stop*.
- Step 5** Touching only the metal card carrier, use your free hand to support the bottom of the CSF and slide the card completely out of the chassis.
- Always place the CSF directly into an antistatic bag or other ESD-preventive container.
 - If you plan to return the defective CSF to the factory, repackage it in the shipping container you received with the replacement card.
- Step 6** Set both edges of the CSF carrier into the card slot carrier alignment grooves on either side of the CSF slot and slide the card halfway into the chassis.
- Step 7** Pivot the ejector levers outward away from the faceplate.
- Step 8** Slide the card into the CSF slot until the ejector levers make contact with the front of the card cage, then *stop*.
- Step 9** Pivot the ejector levers toward the faceplate until the connector properly seats in the backplane.
- Step 10** Tighten the two captive screws.



Caution Do not overtighten the captive screws; over tightening can strip the threads on the screw or in the insert in the CSF faceplate.

- Step 11** Power on the router.
- If the router does not power on correctly, see the “Troubleshooting the Line Cards” section on page 4-19.
-

Upgrading the RP and Line Card Memory

Upgrading the RP and line card memory is presented in the *Cisco XR 12000 Series Router Memory Replacement Instructions*. This document contains the latest information about memory requirements and replacing memory on the Cisco XR 12404 router RP and line cards. Consult this publication before replacing memory on your RP or line card, or adding memory to your RP or line card.

You can find Cisco XR 12000 Series Router memory replacement instructions at Cisco.com.



APPENDIX **A**

Technical Specifications

This appendix contains the following sections:

- Product Architecture, page A-2
- Compliance Information, page A-5
- Regulatory, Compliance, and Safety Information, page A-8

Product Architecture

Table A-1 lists system level requirements for the Cisco XR 12404 Router.

Table A-1 Cisco XR 12404 Router Product Architecture

Feature	Description
Slot Capacity	4 slots 3 OC-192 capable I/O slots 1 RP slot that is 10G capable 1 CSF/alarm card
Chassis	One card cage with five slots, three OC-192 pitch slots, one RP slot and one CSF slot
Height	Not to exceed 8.75 inches; supports 8 systems per 7 ft. rack
Width	19 inch rack mountable
Depth	27.85 in. (70.74 cm) maximum
Switching Capacity	10 Gbps full-duplex switching capacity per slot. This includes the RP slots. Each slot capable of supporting all current and future Engine 0, Engine 1, Engine 2, Engine 3 and Engine 4 based line cards. Specific interfaces include OC-192c, QOC-48c, 10GE, 10x1GE, 3xGE, 1xGE, 8xFE, and other 10GiG cards. The switching capacity is required to handle all four 10GiG capable slots (including RP), thus the total switching capacity will be 80 Gbps full-duplex
Cooling	Side-to-side cooling
Power Supplies	110V AC 220V AC DC (optional)

Table A-1 Cisco XR 12404 Router Product Architecture (continued)

Feature	Description
Power Requirements	110V AC power, sufficient to manage three OC-192c/10GE capable line cards and one 10G capable RP. Total power supplied to the system should not exceed 1200VA Two AC or DC power supplies in redundant configuration should be able to support the entire power needs of the chassis.
Power Supply Redundancy	Redundant and load sharing AC power entry module (PEMs), or Redundant and load sharing DC PEMs and DC power distribution units (PDUs)
Route Processors	Supports up to 2 RPs per system The second RP can be used in any slot ¹ The first RP is inserted in slot 0 (1.25 inch height)
Route Processor Redundancy	Supports online insertion and removal, hot swappable RP redundancy
Switch Fabric	The switch fabric supports up to 80 Gbps of capacity
NEBS	The Cisco 12404 Internet Router is designed to comply with NEBS Level 3 certification

1. A narrow card filler panel must be used to ensure proper air flow through the chassis and electromagnetic compatibility (EMC)

Specifications

Table A-2 lists Cisco XR 12404 Router physical specifications. Table A-3 lists the environmental specifications.

Table A-2 Cisco XR 12404 Router Physical Specifications

Description	Value
Frame height	8.75 inches (22.2 cm)
Frame width	19 inches (48.3 cm)
Frame depth	26 inches (66.0 cm)
Weight	
Maximum configuration	103 pounds (46.7 kg)
Minimum configuration	73 pounds (33.1 kg) (without line cards)

Table A-3 Cisco XR 12404 Router Environmental Requirements

Environmental Requirements	Ranges
Temperature	32 to 104F (0 to 40 C) operating -4 to 149F (-20 to 65 C) non-operating -5 to 133F (-23 to 55 C) Max operating for 96 hrs. only
Humidity	10 to 90% non-condensing operating 5 to 95% non-condensing non-operating
Altitude	0 to 10,000 ft. (0 to 3,050 m) operating 0 to 30,000 ft. (0 to 9,144 m) non-operating
Heat dissipation	3,343 Btu/hr. maximum
Cooling	Facing the router, right side-to-side cooling
Shock	5 to 500 Hz, 0.5g (0.1 oct/min ¹) operating 5 to 100Hz, 1g (0.1 oct/min) non-operating 100 to 500Hz, 15g (0.2 oct/min) 500 to 1,000Hz, 1.5g (0.2 oct/min)

1. oct/min = Octave per minute

**Caution**

Exhaust from other equipment vented directly into the Cisco XR 12404 Router air inlet may cause overheating. Install the router so that it is protected from a direct flow of hot air from other equipment.

Compliance Information

Compliance information for the Cisco XR 12404 Router is presented in the following tables:

- Table A-4, “Electromagnetic Emissions Requirements”
- Table A-5, “Immunity Tests”
- Table A-6, “Network Equipment Building Systems—NEBS”
- Table A-7, “European Telecommunication Standards Institute—ETSI”
- Table A-8, “Safety Approval Requirement”

Table A-4 ***Electromagnetic Emissions Requirements***

Country	Standard Requirements	Class: Up to 1 GHz
Australia	AS/NZS 3548:1995	A
Canada	ICES003-1998/CISPR22:1996	A
Hungarian	MSZEN55022	A
Japan	VCCI V-3/99.04	A
Korea	EN55022-1998/EN50082-1	A
New Zealand	AS/NZS 3548:1995	A
Singapore	CISPR22:1996	A
Taiwan	BSMI/CNS 13438	A
USA	FCC CFR 47-PART 15 1998	A ¹
China/others	CISPR22:1997	A
Europe/EU	EN55022-1998/EN55024-ITE	B

Compliance Information
Table A-4 Electromagnetic Emissions Requirements (continued)

Country	Standard Requirements	Class: Up to 1 GHz
ETSI	EN 300386-2/EN55022	B (Noncentral office)

1. Up to 40 GHz

Table A-5 Immunity Tests

Test Type or Specification	Applies to	Class/Level/Criteria
Electrostatic Discharge EN61000-4-2:1995	System/enclosure	Level 4/8KV contact, 15KV air/B
Radiated Immunity IEC61000-4-3:1995 ENV50140:1993	System/enclosure	Level 3/10V/m/A 1KHz 80% AM (80MHz - 1 GHz)
Fast Transients EN61000-4-4:1995	AC power lines DC lines Signal lines	Level 4/4KV 2.5 kHz Rep Freq/B Level 4/4KV 2.5 kHz Rep Freq/B Level 4/1KV 5kHz Rep Freq/A Level 4/2 KV 5kHz Rep Freq/B
Surge Immunity EN61000-4-5:1995	AC power line (live-neutral) 2 ohms AC power line (live-earth) 12 ohms DC power line (live-earth) DC Power line (return-earth) Signal lines 2 ohms	Class 4/2KV/B Class 4/4KV/B Class 4/500V/B Class 4/500V/B Indoor: 500V Outdoor: 4KV/R

Table A-5 Immunity Tests (continued)

Test Type or Specification	Applies to	Class/Level/Criteria
Conducted RF Immunity EN61000-4-6:1996+ ENV50141:1993	AC power line DC power line Signal lines	Level 3/10V/A (150kHz-80MHz)
Voltage Dips + Sag Interruptions AC Power Lines EN61000-4-11:1995	AC power lines	30% 10 ms (0.5 Period)/B 30% 5000ms (25 Periods) 60% 100 ms (5 Periods)/C 60% 1000 ms (50 Periods) >95% 10ms (0.5 Period)/C >95% 5000 ms (250 Periods)

Table A-6 Network Equipment Building Systems—NEBS**NEBS Requirements**

SR-3580—NEBS criteria levels (Level 3-compliant)

GR-1089-Core—NEBS EMC and safety

GR-63-Core—NEBS physical protection

Table A-7 European Telecommunication Standards Institute—ETSI**ETSI Specifications**

ETS 300 386-1—Levels for equipment with a “high priority of service” that is installed in “locations other than telecommunication centers.”

ETS 300 386-2:1997—Levels for equipment with a “high priority of service” that is installed in “locations other than telecommunications centers.”

ETSI 300 132-2: September 1996—DC power supply interfaces at the input to telecommunications equipment Sections 4.8, 4.9.

Table A-8 Safety Approval Requirement

Category	Approval Agency and Requirement
Safety Certification	UL 1950 CSA-22.2 No. 950 EN60950 ACA TS001 AS/NZS 3260 IEC60950 EN60825

Regulatory, Compliance, and Safety Information

This section includes regulatory, compliance, and safety information in the following sections:

- Translated Safety Warnings and Agency Approvals, page A-8
- Electromagnetic Compatibility Regulatory Statements, page A-8

Translated Safety Warnings and Agency Approvals

The complete list of translated safety warnings and agency approvals is available in the *Regulatory Compliance and Safety Information for Cisco 12000 Series Routers* publication (Document Number 78-4347-xx).

Electromagnetic Compatibility Regulatory Statements

FCC Class A Compliance

This equipment has been tested and found to comply with the limits for a Class A digital device, pursuant to part 15 of the FCC rules. These limits are designed to provide reasonable protection against harmful interference when the equipment is operated in a commercial environment. This equipment generates, uses, and can radiate radio-frequency energy and, if not installed and used in accordance with the instruction manual, may cause harmful interference to radio communications.

Operation of this equipment in a residential area is likely to cause harmful interference, in which case users will be required to correct the interference at their own expense.

Modifying the equipment without Cisco authorization may result in the equipment no longer complying with FCC requirements for Class A digital devices. In that event, your right to use the equipment may be limited by FCC regulation and you may be required to correct any interference to radio or television communication at your own expense.

You can determine whether your equipment is causing interference by turning it off. If the interference stops, it was probably caused by the Cisco equipment or one of its peripheral devices. If the equipment causes interference to radio or television reception, try to correct the interference by using one or more of the following measures:

- Turn the television or radio antenna until the interference stops.
- Move the equipment to one side or the other of the television or radio.
- Move the equipment farther away from the television or radio.
- Plug the equipment into an outlet that is on a different circuit from the television or radio. (That is, make certain the equipment and the television or radio are on circuits controlled by different circuit breakers or fuses.)

CISPR 22

This apparatus complies with CISPR 22/EN55022 Class B radiated and conducted emissions requirements.

Canada

English Statement of Compliance

This class A digital apparatus complies with Canadian ICES-003.

French Statement of Compliance

Cet appareil numérique de la classe A est conforme à la norme NMB-003 du Canada.

Europe—EU

This apparatus complies with EN55022 Class B and EN55024 standards when used as ITE/TTE equipment, and EN300386 for Telecommunications Network Equipment (TNE) in both installation environments, telecommunication centers and other indoor locations.

VCCI Class A Notice for Japan



Warning

This is a Class A product based on the standard of the Voluntary Control Council for Interference by Information Technology Equipment (VCCI). If this equipment is used in a domestic environment, radio disturbance may arise. When such trouble occurs, the user may be required to take corrective actions.

Statement 191

警告 これは、情報処理装置等電波障害自主規制協議会（VCCI）の規定に基づくクラスA装置です。この装置を家庭環境で使用すると、電波妨害を引き起こすことがあります。この場合には、使用者が適切な対策を取るよう要求されることがあります。

Class A Notice for Hungary

**Warning**

This equipment is a class A product and should be used and installed properly according to the Hungarian EMC Class A requirements (MSZEN55022). Class A equipment is designed for typical commercial establishments for which special conditions of installation and protection distance are used. Statement 256

Figyelem

Figyelmeztetés a felhasználói kézikönyv számára: Ez a berendezés "A" osztályú termék, felhasználására és üzembe helyezésére a magyar EMC "A" osztályú követelményeknek (MSZ EN 55022) megfelelően kerülhet sor, illetve ezen "A" osztályú berendezések csak megfelelő kereskedelmi forrásból származhatnak, amelyek biztosítják a megfelelő speciális üzembe helyezési körülményeket és biztonságos üzemelési távolságok alkalmazását.

Class A Notice for Taiwan and Other Traditional Chinese Markets

**Warning**

This is a Class A Information Product, when used in residential environment, it may cause radio frequency interference, under such circumstances, the user may be requested to take appropriate countermeasures. Statement 257

警告

這是甲類資訊產品，在居住環境中使用時，可能會造成射頻干擾，在這種情況下，使用者會被要求採取某些適當的對策。

Class A Notice for Korea

**Warning**

This is a Class A Device and is registered for EMC requirements for industrial use. The seller or buyer should be aware of this. If this type was sold or purchased by mistake, it should be replaced with a residential-use type.

Statement 294

주의 A급 기기 이 기기는 업무용으로 전자파 적합 등록을 한 기기이
오니 판매자 또는 사용자는 이 점을 주의하시기 바라며 만약
잘못 판매 또는 구입하였을 때에는 가정용으로 교환하시기 바랍니다.



INDEX

Numerics

100BASE-T

- maximum cable lengths **3-23**
- specifications **3-22**
- transmission recommendations **3-22**

A

AC power

- cords **2-14**

air filter, troubleshooting **4-21**

air flow

- cleaning filter **5-8**

- description **1-21**

alphanumeric LEDs **1-8, 4-15**

antistatic bag **5-36**

attaching cables

- auxiliary and console port **3-15**

autosensing scheme **1-6**

auxiliary port **1-7**

B

bandwidth **1-6**

baud rate **3-14**

boot image **1-9**

booting system **3-32**

boot process, troubleshooting **4-2**

bracket installation **3-5**

C

cable-management system **5-32**

- recommendations **2-9**

cables

- 100BASE-T **3-23**

- AC power **2-13**

- DC power **2-14**

captive screws

- power-on **3-28**

captive screws, overtightening **5-33, 5-36**

card-handling **5-31**

center-mount brackets **3-5**

chassis, rack installation **3-7**

Cisco 12006 Series

electromagnetic compatibility regulatory statements **A-8**
 electromagnetic emissions compliance **A-5**
 ETSI compliance **A-7**
 immunity test compliance **A-6**
 NEBS compliance **A-7**
 safety approval compliance **A-8**
 translated safety warnings **A-8**

clock progress **4-2**

codes, electrical **2-4, 2-14**

commands

- show environment **4-9, 4-12**
- show environment all **4-21**
- show environment table **4-21**

compliance information

- electromagnetic compatibility regulatory statements **A-8**
- electromagnetic emissions requirements **A-5**
- ETSI specifications **A-7**
- immunity tests **A-6**
- NEBS compliance requirements (table) **A-7**
- safety approval requirements (table) **A-8**
- translated safety warnings and agency approvals **A-8**

connecting AC-power **3-24**

connector

- auxiliary port **3-17**
- console port **3-16**

console and auxiliary port attachments **3-14**

console port, pinouts **3-16**
 cooling subsystem

- environmental shutdown **4-20**
- troubleshooting **4-19**

CPU cache memory **1-9**

CSC ejector levers **5-36**

CSF to factory **5-36**

D

data bits **3-14**
 Data Set Ready (DSR) **3-14**
 DC-power entry module

- electrical codes **2-4**

DC voltages, internal **4-4**

E

earth ground connection **3-9**
 ejector levers, CSC **5-36**
 electrical

- codes **2-14**

electrical codes **2-4**

electromagnetic compatibility **3-14**

electromagnetic interference

- See EMI

electromagnetic pulse

- See EMP

EMC

NEBS EMC requirements **A-7**
 regulatory compliance statements **A-8**

EMI

approvals **A-8**
 prevention **2-15**

EMP **2-16**

environmental monitoring, MBus **1-25**

ESD-preventive container **5-36**

Ethernet port

attachments **3-21**
 description **1-6**

Exhaust from other equipment **1-21**

F

Fast Ethernet specifications **3-22**

flash memory

cards **1-9**
 card slot **1-5**

H

handling cards **5-31**

I

IEEE 802.3u specifications **3-23**

immunity approvals **A-8**

initialization sequence **4-16**

installation

chassis **3-7**
 tools required **2-2**

interface cables and connections **3-17**

interrupt function **1-7**

L

laser safety **2-6**

LED displays, RP **4-14**

LEDs

line cards **4-19**
 route processor **4-15, 4-16**
 startup **4-4**
 troubleshooting power supplies **4-6, 4-9**

line card

alphanumeric display **4-19**
 diagnostics **4-19**
 removing **5-30**

M

maintenance bus **1-24**

MBus, for troubleshooting **4-2**

MDI RJ-45 receptacle **3-20**

MII cable specifications **3-23**

monitoring clock progress **4-2**

monitor mode **1-7**

N

NEBS

- compliance **A-7**
- supplemental bonding and grounding connection **3-9**

NMI switch **1-7**nonmaskable interrupt **1-7**

NVRAM

- PRP description **1-12**
- size **4-16**

Oobserving initial conditions **3-28**overtemperature conditions **4-21**

Pparity **3-14**part numbers **1-12**PCMCIA slot **1-5**pinouts console port **3-14, 3-16**plant wiring **2-15**POST (power-on self-test) **4-13**

power

- recommendations and requirements **2-13**
- surge suppression **2-16**

power-on, first time **3-28**

power subsystem

DC-DC power converters **4-5**

processor

- CPU on the PRP **1-5**
- subsystem, troubleshooting **4-13**

PRP

- alphanumeric LED displays **4-15**
- auxiliary port **1-7**
- Cisco IOS XR software images **1-11**
- console port function **1-7**
- DRAM configurations **1-11**
- Ethernet port **1-6**
- LEDs **4-14**
- memory components **1-9**
- NVRAM **1-12**
- soft reset switch **1-7**
- SRAM **1-11**

R

rack-mounting

- frame **3-7**
- guidelines **2-9**
- ventilation **3-2**

radio frequency interference **2-16**replacing line card **5-31**replacing RP or line card **5-29**reset switch, PRP **1-7**

RJ-45

- 1FE cable specifications **3-22**

- RJ-45 ports **1-6**
 - ROM monitor mode **1-7**
 - router startup **3-28**
 - RP
 - LED front panel **4-17**
 - LEDs **4-17**
 - soft reset switch **4-15**
 - RP soft reset (NMI) switch **4-15**
-
- S**
- safety
 - approval agency requirements **A-8**
 - extra-low voltage requirements **2-4**
 - lifting **2-6**
 - serial ports, asynchronous
 - See auxiliary port; console port
 - show environment all command **4-21**
 - show environment command **4-9, 4-12**
 - show environment table command **4-21**
 - site requirements
 - power **2-15**
 - rack mounting **2-8**
 - supplemental earth ground connection **3-9**
 - system grounding **2-15, 3-8**
 - soft reset (NMI) switch **1-7, 4-15**
 - specifications
 - dimensions **A-4**
 - Fast Ethernet (100BASE-T) **3-22**
 - IEEE 802.3u **3-23**
 - physical **A-4**
 - starting the router **3-28**
 - startup problems **4-2**
 - stop bits **3-14**
 - supplemental bonding and grounding connection **3-9**
 - switches, PRP soft reset **1-7**
 - switch fabric, description **1-17**
 - system
 - booting for first time **3-32**
 - grounding DC-powered installations **3-9**
 - lifting safely **2-6**
 - power guidelines **2-13**
 - supplemental bond and ground connection description **3-10**
 - supplemental earth ground connection **3-9**
-
- T**
- Telcordia GR-1089 NEBS standard **3-14**
 - temperatures **4-21**
 - transmission recommendations
 - 100BASE-T **3-22**
 - troubleshooting
 - boot process **4-2**
 - checking the blower modules **4-4**
 - cooling subsystem **4-19**
 - damaged AC power cord **4-7**
 - damaged DC power wiring **4-12**

- DC-input power subsystem **4-13**
- power problems **4-2**
- power subsystem **4-6, 4-9**
- processor subsystem **4-18**
- startup problems **4-2**

troubleshooting power subsystem **4-6**

twisted-pair wiring **2-16**

U

UPS **2-13, 2-15, 3-25, 3-27**

V

voltages **4-21**

W

wiring

- DC power **2-14**
- plant wiring **2-15**
- PRP Ethernet port connections **3-18**

Free Manuals Download Website

<http://myh66.com>

<http://usermanuals.us>

<http://www.somanuals.com>

<http://www.4manuals.cc>

<http://www.manual-lib.com>

<http://www.404manual.com>

<http://www.luxmanual.com>

<http://aubethermostatmanual.com>

Golf course search by state

<http://golfingnear.com>

Email search by domain

<http://emailbydomain.com>

Auto manuals search

<http://auto.somanuals.com>

TV manuals search

<http://tv.somanuals.com>