



Installing and Configuring the Server Switch

This chapter describes installing and configuring the Server Switch Module and configuring the password and system clock. Additional configuring includes synchronizing with NTP and extending an InfiniBand fabric.

This chapter contains the following sections:

- [Installing the Server Switch Module, page 2-1](#)
- [Downloading Operating System Software from Cisco.com, page 2-1](#)
- [Configuring the Server Switch Module, page 2-2](#)
- [Connecting Beyond BladeCenter, page 2-4](#)

Installing the Server Switch Module

To install the Cisco Server Switch Module, follow these steps:

-
- Step 1** Ensure that you are properly grounded by attaching the ESD wrist strap to bare skin and attaching the clip on the other end to unpainted metal.
 - Step 2** Choose the I/O slot into which you want to install the Server Switch Module. You must install the module in I/O slot 7 or slot 9.
 - Step 3** Refer to your BladeCenter unit documentation for standard hardware module installation instructions.
-

Downloading Operating System Software from Cisco.com

The operating system associated with the Cisco 4x InfiniBand HCA Expansion Card for IBM BladeCenter can be downloaded from www.cisco.com by using the Technical Support & Documentation link. To download the software, follow these steps:

-
- Step 1** Go to www.cisco.com and log in with your CCO user ID.
 - Step 2** Click **Technical Support & Documentation**.
 - Step 3** Click **Software Downloads**.
 - Step 4** Click **Server Networking & Virtualization Software**.

- Step 5** Click **Cisco InfiniBand Switch Module for IBM BladeCenter** to obtain the operating system TopspinOS v2.6.0.
The software is an ISO image.
- Step 6** Burn the ISO image onto a CD.
The ISO image contains the latest switch operating system software, release notes and other documentation.
-

Configuring the Server Switch Module

To configure the Cisco InfiniBand Server Switch Module, follow these steps:

- Step 1** Open the BladeCenter Chassis Manager log-in screen by launching a Web browser and entering the IP address of the BladeCenter chassis in the address bar.
- Step 2** Log in.
The BladeCenter Chassis Manager interface appears.
- Step 3** Expand I/O Module Tasks in the left-hand navigation tree.
- Step 4** Select **Management** under **I/O Module Tasks** in the left pane.
An I/O Module Management heading appears in the display.
- Step 5** Click the link of the physical slot that holds the Server Switch Module that you want to configure.
A heading appears, where X is the number of the slot.
- Step 6** Enter an IP address for the Server Switch Module in the IP address field of the New Static IP Configuration section.



Note The IP address of the Server Switch Module *must* fall in the same subnet as the modules in the other slots.

- Step 7** Enter a subnet mask or the Server Switch Module in the Subnet mask field of the New Static IP Configuration section.



Note The subnet mask of the Server Switch Module *must* match the subnet mask of the modules in the other slots.

- Step 8** Enter a gateway IP address for the Server Switch Module in the Gateway address field of the New Static IP Configuration section, and then click **Save**.



Note The gateway address of the Server Switch Module *must* match the gateway address of the modules in the other slots.

- Step 9** Open a Telnet session to the Server Switch Module with the IP address that you configured in [Step 6](#). Log in to your Server Switch Module, and then proceed to “[Changing the Default Password](#)” to secure your Server Switch Module. Log in with the default user name of **USERID** and password of **PASSWORD**, where the 0 in **PASSWORD** is a zero.

```
Switch(Cisco BladeCenter)
Cisco BladeCenter login: USERID
Password: xxxxxxxx

Cisco BladeCenter>
```

Changing the Default Password

Change the default password immediately to secure your Server Switch. To change the default administrative password, follow these steps:

- Step 1** Switch to Privileged Exec mode by entering the **enable** command.

```
Cisco BladeCenterH> enable
Cisco BladeCenterH#Switch to Global Configuration mode by entering the configure terminal
command.
Cisco BladeCenterH# configure terminal
Cisco BladeCenterH(config)#
```

- Step 2** Change the password of the user ID by entering the **username** command. Include the following:

- User ID for which you need to change the password (in this case, **USERID**)
- **password** keyword
- New password that you want to apply to the user ID

```
Cisco BladeCenterH(config)# username USERID password n0accE$$
```

- Step 3** Return to User Exec mode by entering the **exit** command with the **all** keyword.

```
Cisco BladeCenterH(config)# exit all
Cisco BladeCenterH>
```

Configuring the System Clock

Configure your system clock immediately so that all system messages include accurate timestamps. You can either configure the clock setting on the onboard Server Switch clock, or you can synchronize your Server Switch to a network time protocol (NTP) server.

To configure the clock settings on the onboard clock, follow these steps:

- Step 1** Switch to Privileged Exec mode by entering the **enable** command.

```
Cisco BladeCenterH> enable
Cisco BladeCenterH#
```

Step 2 Set the on-board clock by entering the **clock set** command with the following variables:

- the time of day in *hh:mm:ss* format
- the day in *dd* format
- the month in *mm* format
- the year in *yy* format

The example that follows sets the date to 1:45 am on June 3rd, 2004:

```
Cisco BladeCenterH# clock set 01:45:00 03 06 04
```

To configure primary, secondary, and tertiary NTP servers to synchronize the Server Switch with the network, follow these steps:

Step 1 Switch to Privileged Exec mode by entering the **enable** command.

```
Cisco BladeCenterH> enable
Cisco BladeCenterH#
```

Step 2 Switch to Global Configuration mode by entering the **configure terminal** command.

```
Cisco BladeCenterH# configure terminal
Cisco BladeCenterH(config)#
```

Step 3 Assign a primary NTP server by entering the **ntp** command with this information:

- **server-one** keyword
- IP address of the NTP server

```
Cisco BladeCenterH(config)# ntp server-one 10.2.0.13
```

Step 4 (Optional, Recommended) Assign a secondary NTP server by entering the **ntp** command with this information:

- **server-two** keyword
- IP address of the NTP server

```
Cisco BladeCenterH(config)# ntp server-two 10.2.0.14
```

Step 5 (Optional, Recommended) Assign a tertiary NTP server by entering the **ntp** command with this information:

- **server-three** keyword
- IP address of the NTP server

```
Cisco BladeCenterH(config)# ntp server-three 10.2.0.15
```

Connecting Beyond BladeCenter

To extend your InfiniBand fabric beyond your BladeCenter cluster, you must configure the priority of the subnet manager on your Server Switch Module, then connect one or more of the external interfaces on your Server Switch Module to an outside InfiniBand fabric.

The device with the highest subnet manager priority becomes the master subnet manager in the InfiniBand network. To configure subnet manager priority, follow these steps:

Step 1 Switch to Privileged Exec mode by entering the **enable** command.

```
Cisco BladeCenterH> enable
Cisco BladeCenterH#
```

Step 2 Switch to Global Configuration mode by entering the **configure** command.

```
Cisco BladeCenterH# configure
Cisco BladeCenterH(config)#
```

Step 3 Configure the priority of the subnet manager by entering the **ib sm** command with this information:

- **subnet-prefix** keyword
- Subnet prefix of the InfiniBand network to which the Server Switch belongs
- **priority** keyword
- Priority integer value of the subnet manager (1 is the lowest the priority)

```
Cisco BladeCenterH(config)# ib sm subnet-prefix fe:80:00:00:00:00:00:00 priority 1
```

Step 4 Exit Global Configuration mode.

```
Cisco BladeCenterH(config)#exit
Cisco BladeCenterH#
```

Step 5 Save the configuration by entering the copy running-config startup-config command.

```
Cisco BladeCenterH# copy running-config startup-config
Cisco BladeCenterH#
```

After you configure your subnet manager priority, connect your Server Switch Module to the outside InfiniBand fabric. By default, the external interfaces on your Server Switch Module auto-negotiate speed with the fabric.

Connecting InfiniBand Cables

To plug in an InfiniBand cable, push the connector into the interface until you hear/feel a click.

To remove a cable with a pull connector, grasp the connector with one hand and push it *toward* the port, then pull the latch away from the port with your other hand and gently wiggle the connector away from the port.

Figure 2-1 Removing a Pull Connector

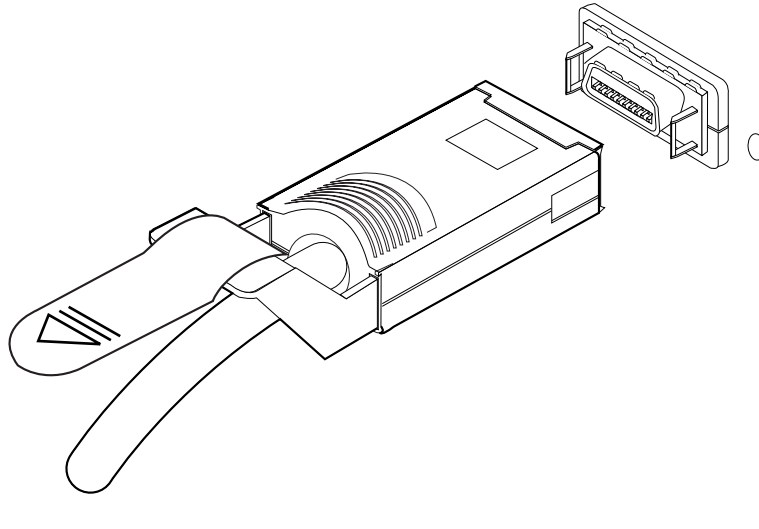

15-4590

Free Manuals Download Website

<http://myh66.com>

<http://usermanuals.us>

<http://www.somanuals.com>

<http://www.4manuals.cc>

<http://www.manual-lib.com>

<http://www.404manual.com>

<http://www.luxmanual.com>

<http://aubethermostatmanual.com>

Golf course search by state

<http://golfingnear.com>

Email search by domain

<http://emailbydomain.com>

Auto manuals search

<http://auto.somanuals.com>

TV manuals search

<http://tv.somanuals.com>