

Combination Sleever, Bosom, Body and Yoke Press

— Installation —

CSBBYMV

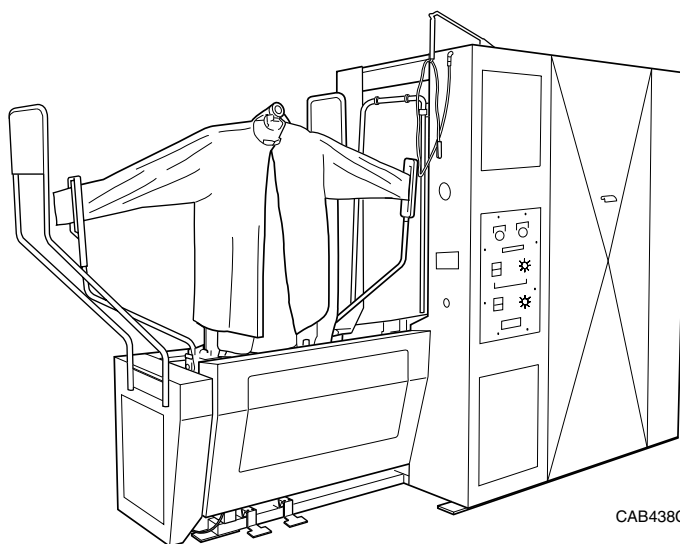

CAB438C



WARNING

**Read and understand these instructions
before operating or servicing these machines.**

Keep These Instructions for Future Reference.

(If this machine changes ownership, this manual must accompany machine.)



An LSG Company
831 South First Street, P.O. Box 32270
Louisville, KY 40232-2270
Phone: (502) 587-1292
Sales Fax: (502) 585-3625
Service/Parts Fax: (502) 681-1275

www.cissellmfg.com

Part No. AJ0976
March 2004

Table of Contents

Safety Information	3
Explanation of Safety Messages.....	3
Important Safety Instructions	3
Operation	5
Overall Dimensions and Connecting Data	5
Dimensions and Specifications.....	6
Utility Specifications	7
Electric	7
Compressed Air	7
Steam.....	7
Steam Return.....	7
Shipping Information	8
Materials Required.....	8
Receiving Inspection	9
Moving and Locating Press	9
Foundation Requirements.....	9
Uncrating	9
Anchoring and Leveling Press.....	10
Items Shipped in Box.....	11
Connecting Steam Supply and Returns	11
Connecting Air Service.....	12
Connecting Electrical Service.....	12
Routing Blower Exhaust from Press.....	13
Final Check-Out Procedures.....	13
Buck Indexing Mechanical Check-Out.....	13
Electrical Check-Out.....	14
Steam Injection and Temperature Check-Out.....	15
Break-In Adjustments	16

© Copyright 2004, Alliance Laundry Systems LLC

All rights reserved. No part of the contents of this book may be reproduced or transmitted in any form or by any means without the expressed written consent of the publisher.

Safety Information

Explanation of Safety Messages

Precautionary statements (“DANGER,” “WARNING,” and “CAUTION”), followed by specific instructions, are found in this manual and on machine decals. These precautions are intended for the personal safety of the operator, user, servicer, and those maintaining the machine.

	DANGER
Indicates an imminently hazardous situation that, if not avoided, will cause severe personal injury or death.	

	WARNING
Indicates a hazardous situation that, if not avoided, could cause severe personal injury or death.	

	CAUTION
Indicates a hazardous situation that, if not avoided, may cause minor or moderate personal injury or property damage.	

Additional precautionary statements (“IMPORTANT” and “NOTE”) are followed by specific instructions.

IMPORTANT: The word “IMPORTANT” is used to inform the reader of specific procedures where minor machine damage will occur if the procedure is not followed.

NOTE: The word “NOTE” is used to communicate installation, operation, maintenance or servicing information that is important but not hazard related.

Important Safety Instructions

Save These Instructions

	WARNING
Failure to install, maintain, and/or operate this machine according to manufacturer’s instructions may result in conditions which can produce serious injury, death and/or property damage.	

NOTE: The WARNING and IMPORTANT instructions appearing in this manual are not meant to cover all possible conditions and situations that may occur. It must be understood that common sense, caution, and carefulness are factors which CANNOT be built into this press. These factors MUST BE supplied by the person(s) installing, maintaining or operating the ironer.

Always contact your dealer, distributor, service agent, or the manufacturer on any problems or conditions you do not understand.

1. Read all instructions before using the press.
2. Refer to the GROUNDING INSTRUCTIONS in the INSTALLATION manual for the proper grounding of the press.
3. Do not allow children to play on or in the press.
4. Do not reach into the press while the press is in operation.
5. Do not install or store the press where it will be exposed to water and/or weather.
6. Do not tamper with the controls.
7. Do not repair or replace any part of the press, or attempt any servicing unless specifically recommended in the user-maintenance instructions or in published user-repair instructions that the user understands and has the skills to carry out.
8. To reduce the risk of an electric shock or fire, DO NOT use an extension cord or an adapter to connect the press to the electrical power source.
9. Use press only for its intended purpose, finishing garments.
10. ALWAYS disconnect the press from electrical supply before attempting any service. Disconnect the power cord by grasping the plug, not the cord.

Safety Information

11. Install the press according to the INSTALLATION INSTRUCTIONS. All connections for steam, electrical power and grounding must comply with local codes and be made by licensed personnel when required.
12. Replace worn power cords and/or loose plugs.
13. Never operate the press with any guards and/or panels removed.
14. DO NOT operate the press with missing or broken parts.
15. DO NOT bypass any safety devices.
16. Failure to install, maintain, and/or operate this press according to the manufacturer's instructions may result in conditions which can produce bodily injury and/or property damage.

NOTE: The WARNINGS and IMPORTANT SAFETY INSTRUCTIONS appearing in this manual are not meant to cover all possible conditions and situations that may occur. Common sense, caution and care must be exercised when installing, maintaining, or operating the press.

Any problems or conditions not understood should be reported to the dealer, distributor, service agent or the manufacturer.

Operation

Overall Dimensions and Connecting Data

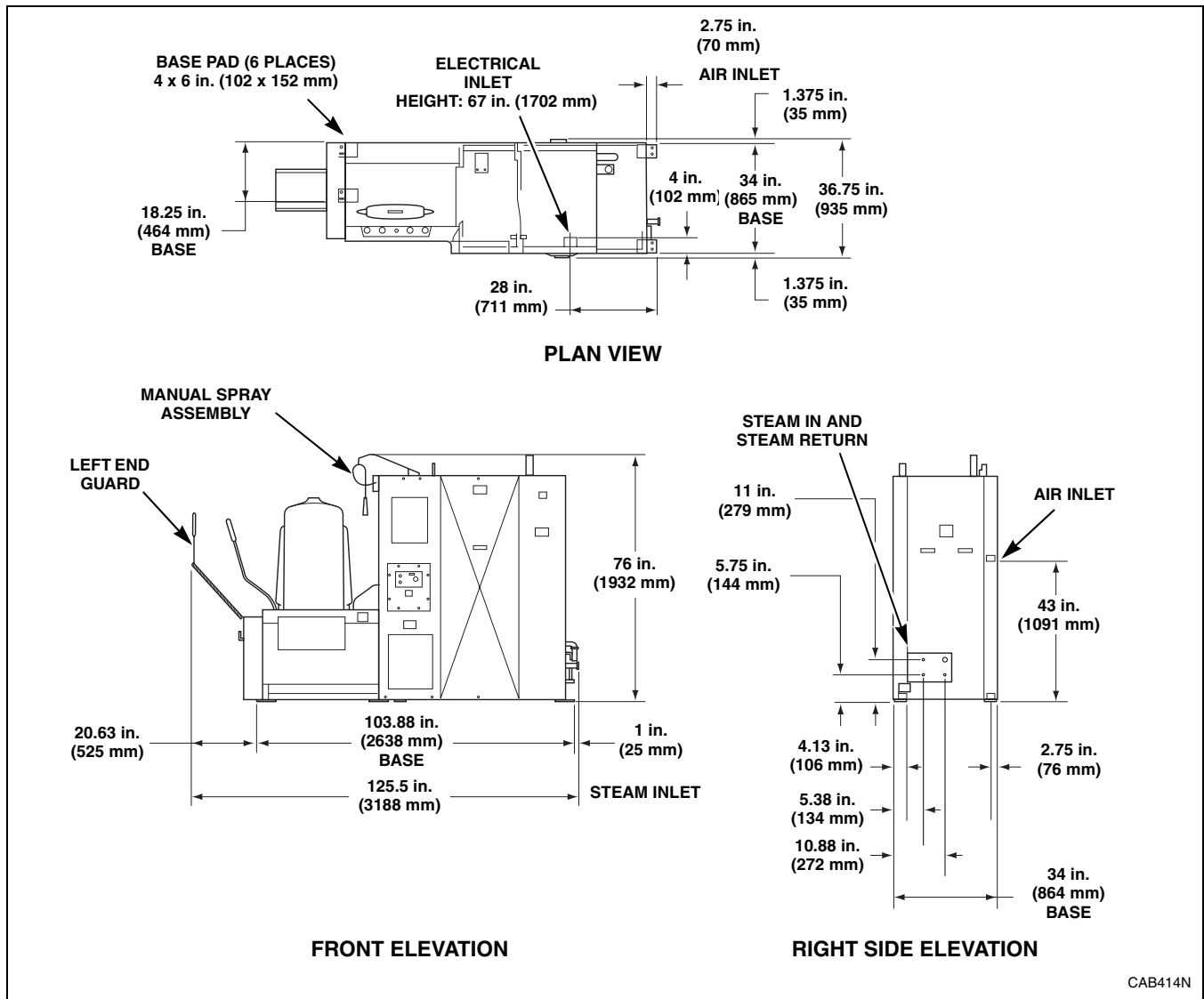

Figure 1

Dimensions and Specifications

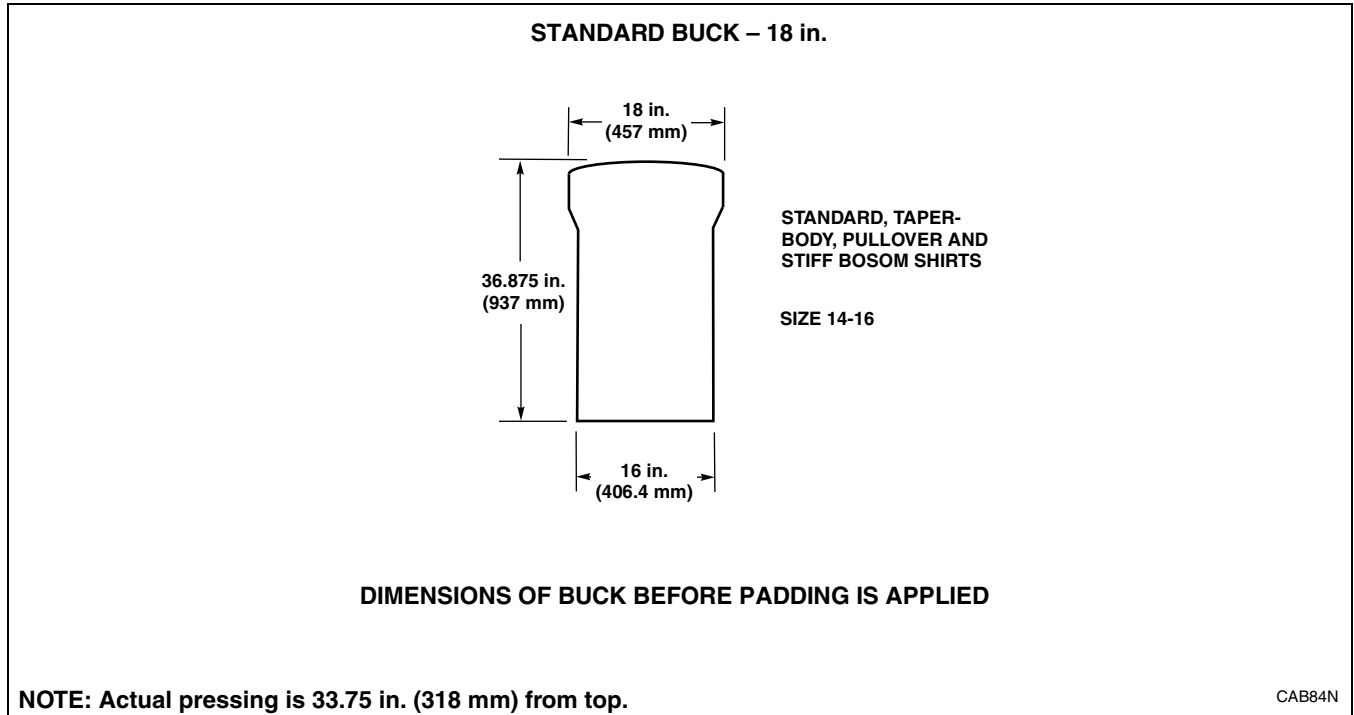

Figure 2

Utility Specifications

Electric

Voltage/Hertz/Phase		200/60/3	230/60/3	460/60/3	575/60/3	220/50/3	380/50/3	415/50/3
Minimum Supply Circuit Conductor Ampacity		30.7	29.5	14.8	16.8	N/A	N/A	N/A
Maximum Rating of Protection Device	Circuit Breaker	50	50	25	30	N/A	25	25
	Dual Element Fuse	60	60	30	35	N/A	30	30
Full Load Amps		24.5	23.6	11.8	13.4	N/A	11.8	11.8
Average Running Amperes		19	18	9	10	N/A	9	9
Number of Primary Power Connections		3+ grd	3+ grd	3+ grd	3+ grd	3+ grd	3+ grd	3+ grd
Wire Size		N/A	N/A	N/A	N/A	N/A	4 x 6 mm ²	4 x 6 mm ²

Motor	60 Hertz HP	60 Hertz RPM	50 Hertz HP	50 Hertz RPM
Sleeve Blower	1	3450	N/A	N/A
Sidebag Blower	4.6	3450	4.0	2875

Compressed Air

	1/4 in. NPT Connection (Clean, Dry Air Required)	
	U.S.A.	Metric
Air Pressure	80 – 100 psig	5.6 – 6.9 bar
Minimum Free Air Consumption	1.2 ft ³ /cycle	034 m ³ /cycle
Suggested Operating Pressure	65 psig	4.48 bar

Steam

	1-1/4 in. NPT Connection	
	U.S.A.	Metric
Maximum Steam Pressure	125 psig	8.6 bar
Suggested Operating Pressure	110 psig	7.58 bar
Consumption @ 105 psig	86 lbs/hr	39 kg/hr
Steam Rating @ 105 psig	2.5 bhp	24.51 kW

Steam Return

	1/2 in. NPT Connection (3 Places)	
	U.S.A.	Metric
Flow-rate @ 100 psig	86 lbs/hr	39 kg/hr

Operation

Shipping Information

	U.S.A.	Metric
Length	111 in.	282 cm
Width	42 in.	107 cm
Height	82 in.	208 cm
Weight	2470 lbs.	1120 kg

NOTE: Applicable codes, ordinances, specifications and/or other governing data related to installation must be complied with. The materials listed in Table 1 may or may not conform to these requirements.

Materials Required

Quantity	Description	Source
1	Lockout type fused disconnect switch suitable for the electric service connected to the press (refer to wiring schematic in control box) (not required if circuit breaker is used)	Local
As required	Wire of suitable size, type and length to connect the electric service to the press (refer to wiring schematic in control box)	Local
As required	Flexible conduit and connections to encase the wires and make connections (refer to wiring schematic in control box)	Local
3	Steam trap and check valve, or combination steam trap/check valve sized steam return lines and steam consumption	Local
3	Ball shut-off valves sized for steam supply, return lines and air supply	Local
As required	Pipe, couplings, unions, flanges, etc., to connect steam supply and return lines and air supply line to press. Wall thickness of pipe and tubing must be in compliance with recommendations by compressor and boiler manufacturers and local code.	Local
6	5/8 in. anchor bolts	Local
As required	Machinery grout (if machine sits 1/2 in. [12.7 mm] or greater off of floor)	Local
As required	Pipe, couplings, unions, flanges, etc., to route air bag blower exhaust away from the press	Local

Table 1

Receiving Inspection

The press is shipped assembled and enclosed in a plastic cover and crate. Upon delivery, inspect crate and contents for shipping damage. If crate or cover is damaged, or signs of possible damage are evident, have carrier note the condition on the shipping papers before shipping receipt is signed, or advise carrier of condition when discovered.

Remove protective cover and check items received against items listed on packing list. If any item is damaged or missing, a written claim should be filed with the carrier as soon as possible.

Moving and Locating Press

IMPORTANT: If a forklift is used to move the press, exercise care that forklift arms are inserted under the frame and do not contact any operating mechanism.

Move press to the installation location while it is still attached to skid. However, press can be removed from skid before moving.

To remove unit from skid, unscrew the four shipping cap screws from the attaching holes and work press from skid.

Press should be located in an area that provides a minimum of 24 inches (61 cm) between press and any structure.

IMPORTANT: The above dimensions are considered minimum working and maintenance dimensions and should be increased if possible.

Foundation Requirements

Install press on a solid, level floor such as concrete.

IMPORTANT: Installation on a wooden floor can cause machine to shift, which will result in misalignment of heads and bucks and damage to both press and garments.

Floor should be capable of supporting 125 pounds (56.7 kilograms) per square foot. Remove all floor covering material (tile, wood, carpeting, etc.) from press mounting area.

Uncrating

1. Remove wooden crate. Move the press to area of final location and remove wooden skid. Remove all panels.

	WARNING
<p>To avoid possible serious injury:</p> <ul style="list-style-type: none"> • ALWAYS be careful to AVOID spring-loaded components when working inside press. • Installation MUST be performed ONLY by qualified service personnel. 	
<small>W336</small>	

2. Install left end guard using attached hardware before opening press heads. Refer to *Figure 1* for location if needed.
3. Remove any shipping material on heads and buck.
4. Carefully remove any shipping braces using a hammer or any long-handled striking device, to knock shipping braces away from unit. Avoid using excessive force to remove brace. Excessive force applied to the braces can result in damage to unit and/or alignment of internal parts.

Anchoring and Leveling Press

Refer to *Figure 3*.

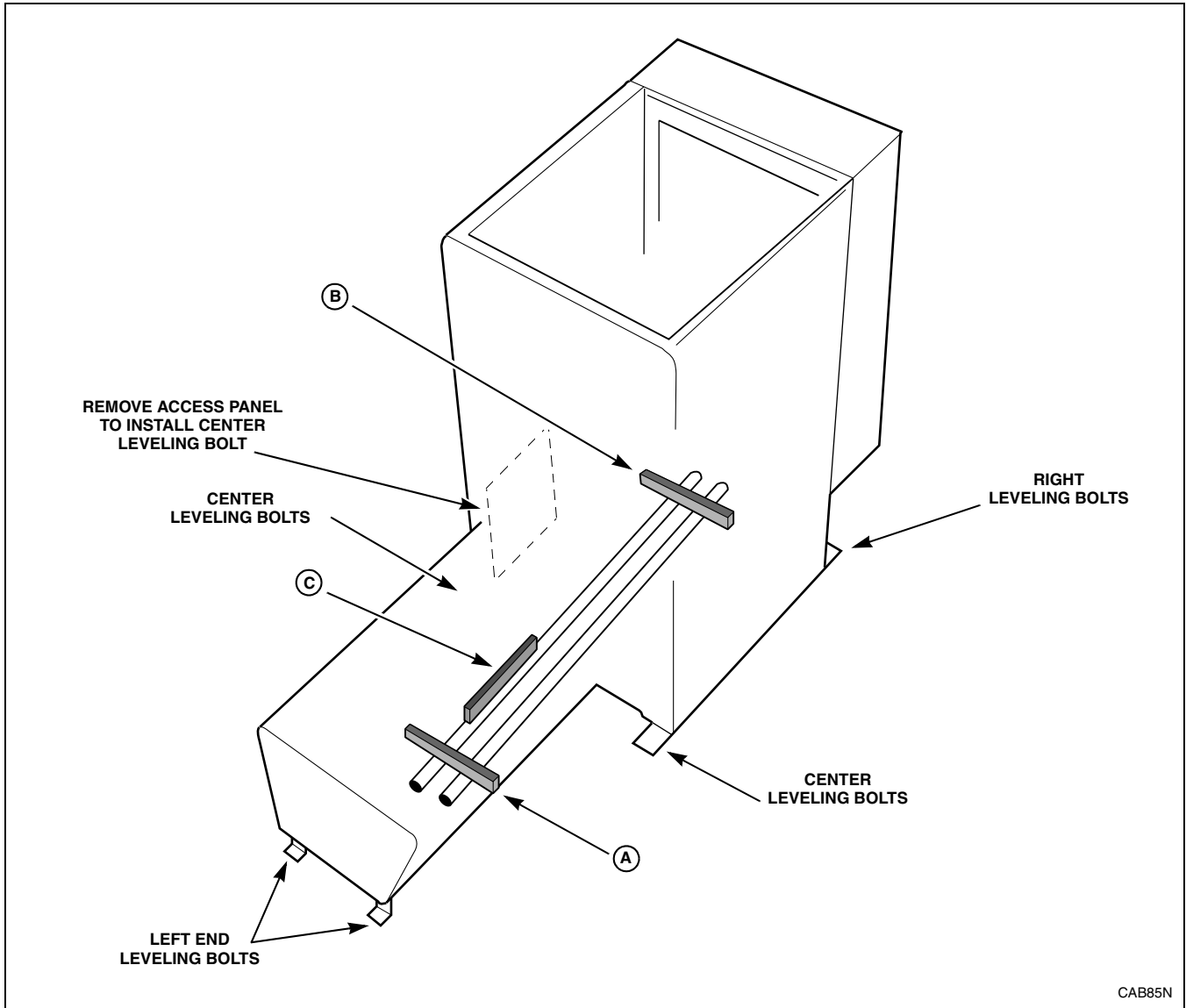

Figure 3

1. Place machine in desired location.
2. Trace the 6anchoring holes onto the floor.
3. Move the press aside.
4. Drill the floor in all 6 places with a masonry bit so that it will accept the 5/8"-11 expansion anchors.
5. Insert 5/8"-11 expansion anchors into holes.
6. Using 5/8"-11 Grade 5 expansion bolts, expand each anchor by turning the bolt into the anchor until the bolt is secure and the anchor is fully expanded.

7. Remove the bolts and reposition the machine over the anchors.

IMPORTANT: Leveling the press is required. Failure to follow leveling instructions can cause misalignment of heads and buck and damage to the press and garments, as well as void warranty.

8. Place a level across carriage rails at A and adjust left end leveling bolts. Refer to *Figure 3*.
9. Move level to location B and adjust right end leveling bolts. Refer to *Figure 3*.

10. Place level along inside carriage rail at C and raise or lower either end of press as necessary. Turn leveling bolts equal amounts to maintain alignment at A and B.
11. Use a level to recheck A, B, and C.
12. Turn two center leveling bolts until they just touch the floor.
13. Tighten leveling bolt jam nuts and bolt press to floor.
14. Use a level to recheck A, B and C.
15. Install two 5/8" washers on each of the 5/8"-11 Grade 5 anchoring bolts.
16. Place anchoring bolts with washers into expansion anchors.
17. Tighten all anchor bolts and torque to 80 ft./lbs.
18. Use grout if required.

Items Shipped in Box

A cardboard box is shipped inside press cabinet. It includes:

- Hi-temp lubricant
- Installation and Operation Manuals
- Eccentric wrench

NOTE: Eccentric wrench will be used later for adjusting buck carriage roller throughout life of press. Keep hi-temp lubricant for maintenance.

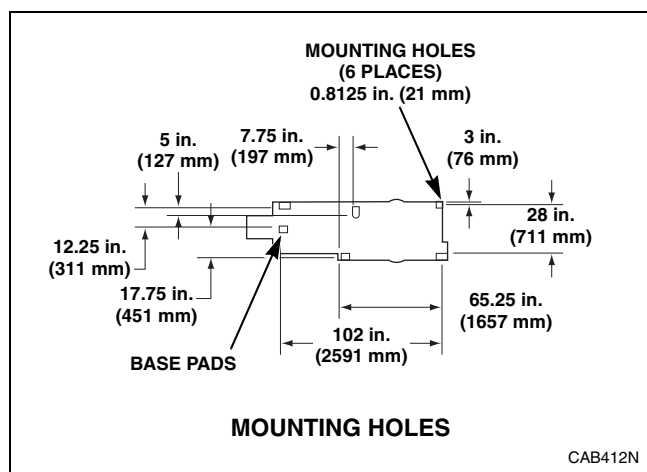

Figure 4

Connecting Steam Supply and Returns

Refer to *Figure 5*.

NOTE: Clean out all pipe lines before connecting them to the press.

IMPORTANT: Failure to properly install suitable traps and check valves and supply correct steam pressure will reduce operating efficiency.

Steam supply connected to press must have a constant minimum pressure of 110 psi (7.58 bar).

The following steps outline the procedure for connecting steam supply and return lines to press.

1. Run a 1-1/4 inch NPT steam line to the steam supply connection with suitable black iron pipe, elbows, strainer, ball valve and union.

IMPORTANT: A minimum 3 inch (7.62 cm) riser should be installed off the supply header to minimize water in the steam supply to the press.

NOTE: It is recommended that a steam strainer be installed between the steam supply and press.

2. Install three suitable 1/2 inch NPT steam traps, unions, check valves and ball valve between steam return connections and steam return lines.

NOTE: Cast iron inverted bucket traps are recommended. Size traps according to steam pressure and consumption found in *Utility Specifications*.

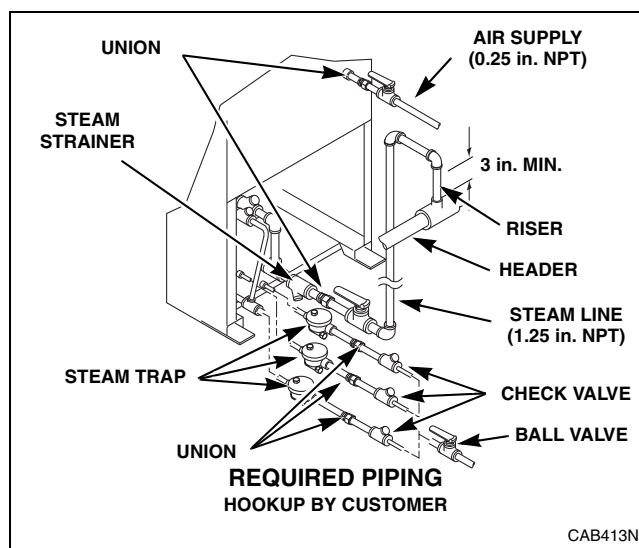

Figure 5

Connecting Air Service

Air service connected to press must have a minimum constant pressure of 75 psi (5.17 bar) and be of ample volume to meet requirements listed in *Utility Specifications* section. Air pressure should be reduced to 65 psi (4.48 bar) at air inlet regulator. It is the responsibility of the customer to connect the air line with galvanized pipe, brass, aluminum or stainless steel pipe, copper tubing, fittings, shut-off valve, union, air filter and air dryer suitable for delivery of clean, dry air to the inlet.

IMPORTANT: Failure to provide clean, dry air to press will cause premature valve failure, unnecessary downtime and void warranty.

NOTE: A shut-off valve and union placed at each unit is recommended.

Connecting Electrical Service

	WARNING
To avoid possible serious injury or death: <ul style="list-style-type: none">• ALWAYS shut off AND lock out ALL electrical power to press BEFORE performing electrical work.	
<small>W368</small>	

IMPORTANT: Improper connections will result in equipment damage and will void the warranty.

1. Install a suitably sized fused disconnect switch or circuit breaker as close to press as practical.
2. Remove one knockout plug from electrical connection box.
3. Connect proper size conduit encased wires to wires inside box.
4. Connect conduit to box.

NOTE: Refer to wiring schematic enclosed in control panel for further details and instructions.

Routing Blower Exhaust from Press

Blower exhaust can add unwanted heat and noise into a room. Route blower exhaust from press upward near ceiling or to outside. Running exhaust outside is recommended. If running exhaust outside, make sure rain cannot get in.

Install exhaust piping from exhaust muffler as follows:

1. Use coupling to connect minimum amount of customer-provided 2-1/2 inch (6.35 cm) pipe (schedule 80 CPVC, copper) to muffler 2 inch (5.08 cm) pipe.
2. Run pipe to ceiling area or outside building. Support pipe as required. The end of the pipe run should be bell shaped and pointed downward to avoid collecting debris.

IMPORTANT: Pipe must be adequately supported. When using CPVC, support the pipe every 5 feet (1.52 m).

NOTE: Use 45 degree bends wherever possible. avoid 90 degree bends.

3. Exhaust can be routed into common header with other presses. Header must be suitably sized. Refer to *Table 2*.

NOTE: Bring pipe into header using Y tee. Angle pipe so air is routed toward opening to atmosphere.

IMPORTANT: Undersized header WILL shorten motor life and void warranty.

No. of Connections	Header Pipe Size
2	2-1/2 in. (6.35 cm)
3	3 in. (7.62 cm)
4	3-1/2 in. (8.89 cm)
5	4 in. (10.16 cm)
6	5 in. (12.70 cm)

Table 2

Final Check-Out Procedures

NOTE: Refer to Operation Manual to identify controls before performing the following check-outs.

Buck Indexing Mechanical Check-Out

The following steps outline the procedure for buck indexing mechanical check-out to the press:

	WARNING
<p>To avoid possible serious injury:</p> <ul style="list-style-type: none"> • BEFORE attempting to pull buck out of cabinet, ALWAYS shut off AND lock out ALL electric, air and steam power to press AND allow heated surfaces to cool • ONLY USE ORANGE HANDLE to push and pull buck IN and OUT of CABINET. 	
<small>W439</small>	

1. Pull buck out to dressing position.
2. Turn on air to press and reset air circuit. Pressure gauge should read line pressure 65 psi.
3. Step on the right foot pedal. Collar clamp should open. Release the foot pedal and collar clamp should close.
4. Step on the left foot pedal. Sleeve extender arms should swing outward away from buck.
5. Press the sleeve extender release button. Sleeve extenders should swing inward toward buck.
6. Simultaneously press and release both BUCK IN buttons. Buck should travel into pressing position inside the cabinet and heads close.
7. Check that the collar block is positioned in the head cutout per *Figure 6*. If collar block is not properly aligned, check press level. If press is level, shim buck, adjust collar block or discharge tube as necessary.

Operation

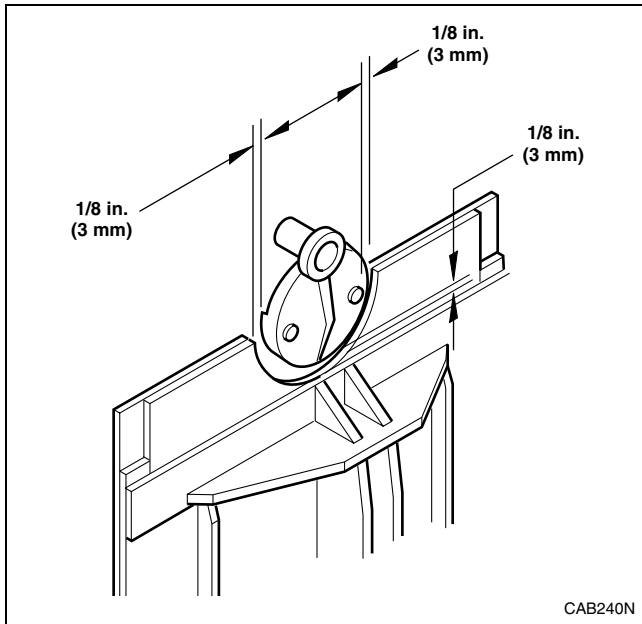



Figure 6

8. Press the head release button. Heads should open and buck should return to the dressing station.
9. Simultaneously press and release both buck in buttons. As buck travels into cabinet, press red safety bar which is near the operator. Buck travel should stop, press heads should remain open and air should exhaust from the system. Pressure gauge should read 0 psi.
10. Reset air to press. Simultaneously press and release both buck in buttons. Allow buck to travel into cabinet and heads to close. Press other red safety bar. Press heads should open, buck should remain stationary and air should exhaust from the system. Pressure gauge should read 0 psi.

	WARNING
To avoid possible serious injury, NEVER use press unless BOTH safety bars and BUCK IN BUTTONS are working properly.	
<small>W369</small>	

11. Reset air to press. Simultaneously press and release both buck in buttons. Allow buck to travel into cabinet and heads to close. Press emergency stop button. Press heads should open, buck should remain stationary and air should exhaust from the system. Pressure gauge should read 0 psi.

Electrical Check-Out

Black and red electrical control buttons start and stop all electrical functions.

1. Reset air to press per step 1 in *Buck Indexing Mechanical Check-Out*. Turn electrical on to press at fused disconnect switch or circuit breaker.
2. Make sure Emergency Stop button is up if applicable.
3. Press black start button.

NOTE: Start button will not start blower unless air is reset to press.

4. Check blower for proper rotation. Check airflow direction at press muffler. Air should be exhausting from muffler. If air is sucked in toward muffler, change any two wires in the electrical connection box.
5. Check isolation damper between sleeve heat exchanger and blower. Air cylinder should extend to open damper.
6. Step on left foot pedal. Vacuum should turn on to buck. Press vacuum release button. Vacuum should turn off to buck.
7. Set cycle timer selector switch to on position and set pressing cycle timer for approximately 35 seconds. Turn steam timer selector switch to off position. Send buck into pressing position. Heads should close and remain closed for approximately 35 seconds.
8. When press heads open, the buck should automatically return to the dressing position.
9. Turn steam timer selector switch to the on position. Set steam timer for 5 seconds. Send buck into pressing position. Blower air should blow through arm holes after a 5 second delay and remain on until cycle timer times out.
10. After all checks (steps 1 through 9) are completed, proceed with *Steam Injection and Temperature Check-Out*.

Steam Injection and Temperature Check-Out

The following checks ensure that the steam supply to the press is of sufficient temperature.

	WARNING
<p>To avoid possible serious injury or death, perform the following BEFORE proceeding to check out:</p> <ul style="list-style-type: none"> • Shut off AND lock out ALL electrical power to press. • Shut off AND lock out ALL air service to press. 	
W370	

Turn electrical power off.

1. Slowly open shut-off valves in both steam supply and return lines.
2. Open needle valve at water gun assembly.
3. Allow press to heat for at least 15 minutes.
4. Check head surface temperature with pyrometer or temperature stick measuring device. Temperature should be 320° to 340°F (160° to 172°C).
5. Inspect all traps for proper operation per manufacturer's instructions.

	WARNING
<p>To avoid possible serious injury, perform the following BEFORE proceeding to step 6:</p> <ul style="list-style-type: none"> • Make sure ALL motion has stopped. • ALWAYS be careful to AVOID spring loaded components when working inside press. • NEVER index buck while checking temperature. 	
W371	

6. Turn on air supply to press and reset air system. Turn on electric power to press. Press black start button. Blower will start. Allow press to heat for an additional 5 minutes.
7. Turn both timers off.
8. Check temperature of air to yoke bag snorkel. Send buck into pressing position. Remove plug from tube at top of heat exchanger and insert pyrometer to take air temperature reading. Temperature should be 350°F (178°C).

IMPORTANT: Failure to perform the required checks and make corrective actions could result in damage to unit and void warranty.

Operation

Break-In Adjustments

As new press is used, working surfaces “seat-in” and friction decreases. This usually results in increased working speed.

These conditions are considered normal in a new press and do not indicate a need for constant maintenance. This initial “break-in” period will vary with usage, but generally occurs during the first week of operation. At this time the following items should be inspected and adjusted if necessary.

1. Recheck the level of press. This is especially important if press is located on wooden flooring.

2. Simultaneously press both buck in buttons to send buck into cabinet and close heads. Check alignment of collar block in head cutout. Check snorkel alignment. Refer to *Figure 6*. Make adjustments if required.
3. Adjust buck in travel speed. If buck is traveling too fast or bottoms out shock absorber, slow indexing cylinder down.
4. Check operation of all operating controls.
5. Inspect press for loose bolts, screws, pipe fittings and carriage rollers, especially on the buck carriage.

	WARNING
<p>To AVOID possible serious injury, BEFORE performing maintenance or repair tasks:</p> <ul style="list-style-type: none">• Shut off AND lock out ALL electric power to the press.• Shut off AND lock out ALL steam service to the press.• Allow heated surfaces to cool.	
<small>W334</small>	

Free Manuals Download Website

<http://myh66.com>

<http://usermanuals.us>

<http://www.somanuals.com>

<http://www.4manuals.cc>

<http://www.manual-lib.com>

<http://www.404manual.com>

<http://www.luxmanual.com>

<http://aubethermostatmanual.com>

Golf course search by state

<http://golfingnear.com>

Email search by domain

<http://emailbydomain.com>

Auto manuals search

<http://auto.somanuals.com>

TV manuals search

<http://tv.somanuals.com>