

# User's Manual

## **CITIZEN**

### **THERMAL LABEL PRINTER**

#### **MODEL CBM - 253**

Japan CBM Corporation

### Declaration of Conformity

Manufacturer's Name : Japan CBM Corporation

Manufacturer's Address: CBM Bldg., 5-68-10, Nakano, Nakano-ku  
Tokyo, 164-0001, Japan

Declare the Product

Product Name: Thermal Label Printer

Model Number(s): CBM-253 Series  
(CBM-253P, CBM-253R)  
(S.No.60400000 ~ )

Conform to the following Standards:

LVD:	EN60950	: 1992+A1+A2:1993
EMC:	EN55022	: 1994 Class B
	EN61000-3-2	: 1995
	EN61000-3-3	: 1995
	EN50082-1	: 1992
	IEC801-2	: 1991 4KV CD, 8KV AD
	IEC801-3	: 1984 3V/m, 26MHz-1GHz, AM1KHz 80%
	IEC801-4	: 1988 0.5KV Signal Line 1KV AC mains

Supplementary Information

“The product complies with the requirements of the Low Voltage Directive 73/23/EEC, 93/68/EEC and the EMC Directive 89/336/EEC, 91/263/EEC, 92/31/EEC, 93/68EEC”

Place Tokyo, Japan

Signature:

Date April.1996



Full Name : Mikio Moriya  
Position : General Manager  
R & D Department

Europe Contact :

Norco Declaration AB  
Box 7146 S-250 07 Helsingborg, Sweden

**Warning**

This is a Class A products. In a domestic environment this product may cause radio interference in which case the user may be required to take adequate measures.

This declaration is applied only for 230V model.

## IMPORTANT SAFETY INSTRUCTIONS

- Read all of these instructions and save them for future reference.
- Follow all warnings and instructions marked on the product.
- Unplug this product from the wall outlet before cleaning. Do not use liquid or aerosol cleaners. Use a damp cloth for cleaning.
- Do not use this product near water.
- Do not place this product on an unstable cart, stand or table. The product may fall, causing serious damage to the product.
- Slots and openings on the back or bottom of the case are provided for ventilation. To ensure reliable operation of the product and to protect it from overheating, do not block or cover these openings. The openings should never be blocked by placing the product on a bed, sofa, rug or other similar surface. This product should never be placed near or over a radiator or heater. This product should not be placed in a built-in installation unless proper ventilation is provided.
- This product should be operated from the type of power source indicated on the marking label. If you are not sure of the type of power available, consult your dealer or local power company.
- Do not allow anything to rest on the power cord. Do not place this product where the cord will be walked on.
- If an extension cord is used with this product, make sure that the total of the ampere ratings of the products plugged into the extension cord does not exceed the extension cord ampere rating. Also, make sure that the total of all products plugged into the wall outlet does not exceed 15 amperes.
- Never push objects of any kind into this product through cabinet slots as they may touch dangerous voltage points or short out parts that could result in a risk of fire or electric shock. Never spill liquid of any kind on the product.
- Except as explained elsewhere in this manual, do not attempt to service this product by yourself. Opening and removing the covers that are marked "Do Not Remove" may expose you to dangerous voltage points or other risks. Refer all servicing on those compartments to service personnel.
- Unplug this product from the wall outlet and refer servicing to qualified service personnel under the following conditions:
  - A. When the power cord or plug is damaged or frayed.
  - B. If liquid has been spilled into the product.
  - C. If the product has been exposed to rain or water.
  - D. If the product does not operate normally when the operating instructions are followed. Adjust only those controls that are covered by the operating instructions since improper adjustment of other controls may result in damage and will often require extensive work by a qualified technician to restore the product to normal operation.
  - E. If the product has been dropped or the cabinet has been damaged.
  - F. If the product exhibits a distinct change in performance, indicating a need for service.
- Please keep the poly bag which this equipment is packed in away from children or throw it away to prevent children from putting it on. Putting it on may cause suffocation.

**IMPORTANT:** This equipment generates, uses, and can radiate radio frequency energy and if not installed and used in accordance with the instruction manual, may cause interference to radio communications. It has been tested and found to comply with the limits for a Class A computing device pursuant to Subpart J of Part 15 of FCC Rules, which are designed to provide reasonable protection against such interference when operated in a commercial environment. Operation of this equipment in a residential area is likely to cause interference, in which case the user at his own expense will be required to take whatever measures may be necessary to correct the interference.

**CAUTION: Use shielded cable for this equipment.**

### **Sicherheitshinweis**

Die Steckdose zum Anschluß dieses Druckers muß nahe dem Gerät angebracht und leicht zugänglich sein.

### **For Uses in Canada**

This digital apparatus does not exceed the class A limits for radio noise emissions from digital, apparatus, as set out in the radio interference regulations of the Canadian department of communications.

### **Pour L'utilisateurs Canadiens**

Cet appareil numérique ne dépasse pas les limites de catégorie A pour les émissions de bruit radio émanant d'appareils numériques, tel que prévu dans les règlements sur l'interférence radio du département Canadien des communications.



**<Cautions>**

1. Before using the equipment, be sure to read this User's manual thoroughly .
2. Portions of the contents of this User's manual may be changed without prior notice.
3. The reproduction of part or all of the contents of this User's manual without permission is strictly forbidden.
4. Absolutely do not carry out maintenance, disassembly, or repair of parts that are not specified in this User's manual.
5. Note that losses which may be attributed to the customer's wrong operation method or usage environment will be outside the responsibility of this company.
6. Do not carry out operations other than those explained in this User's manual, since doing so may become a cause of accidents or breakdowns.
7. Because data is basically transient, long-period and permanent storage of data will not be possible. Please note in advance that this company will not be responsible in any way for losses or lost profits caused through the clearing of data due to breakdowns, repairs, investigations, etc.
8. If any questionable points, mistakes, omitted explanations, etc. are found in the contents of this document, please notify this company.
9. Please note that notwithstanding the conditions in above 8, this company will not be responsible for the consequences of results obtained through operation of this equipment.

## CAUTIONS FOR SAFE USE (Be sure to follow these cautions)

The cautions that must be followed in order to prevent injury to persons using this equipment or to other persons, and to protect against damage to property are displayed as shown below.

- The danger of injury or damage resulting from mistaken methods of use and not following the displayed cautions will be explained as follows:

 <b>WARNING!</b>	<p>The <b>WARNING</b> symbol indicates that if the methods of use is mistaken by not following the explanation given, there will be a possibility of the occurrence of death or serious injury.</p>
 <b>CAUTION</b>	<p>The <b>CAUTION</b> symbol indicates that if the methods of use is mistaken by not following the explanation given, there will be a possibility of the occurrence of problems or physical damage.</p>

 The symbol represents an illustration shown to attract reader's attentions.

 <b>WARNING!</b>
<ul style="list-style-type: none"> <li>• Do not subject this equipment to excessive force or shocks such as by treading on it, dropping it or hitting it, since these actions may result in damage causing a danger of fire or electrical shock. In a situation where the equipment has been damaged, switch off the power, remove the power plug from the mains outlet, and contact your sales shop.</li> <li>• Do not install this equipment in unstable locations that are not flat, since there will be a danger of the equipment falling down or falling over, causing injury.</li> </ul>

**WARNING !**

- Do not install this equipment in locations with poor ventilation, and do not use the equipment in such a way that the ventilation port is obstructed, since these actions may result in fire or electric shock.
- Do not use this equipment in locations such as laboratories in which chemical reactions take place, or in locations in which the air includes salt or toxic gases, since these actions may result in fire or electric shock.
- Do not use this equipment at voltages other than the specified voltage or at frequencies other than at the specified frequencies, since the use other voltages and frequencies may result in breakdowns, creating a danger of fire or electric shock.

In the situation where a breakdown has taken place, switch off the power, remove the power plug from the mains outlet, and contact your sales shop.

- Do not insert or remove the power cables or data cables by pulling on the cables, and do not pull on or carry the main unit in such a way as to subject the cables to force, since these actions will produce the risk of overheating or smoking, creating a source of fire or electric shock.
- Do not drop or insert foreign objects like paper clips or split pins, etc. into the equipment, since these actions may cause breakdowns, creating a danger of fire or electric shock.  
In the situation where a breakdown has taken place. switch off the power, remove the power plug from the mains outlet. and contact your sales shop.
- Do not arrange the power cable so that many plugs are using the same power outlet, since this action will produce a risk of overheating or smoking, creating a source of fire or electric shock.

**WARNING !**

- Do not spill drinks such as tea, coffee or juice, or spray anti-mosquito preparations, etc. onto the equipment, since these actions will result in breakdowns, fire or electric shock.  
If water, etc. has been spilled into the equipment, switch off the power, remove the power plug from the mains outlet, and contact your sales shop.
- Do not attempt to disassemble or modify this equipment, since these actions will cause fire or electric shock.
- The plastic bag that contained the equipment should be stored in a location that is out of the reach of children or should be destroyed, since there is a danger that children may suffocate themselves if they place the bag over their heads.
- Do not attempt to attach anything other than a solenoid, or to attach a solenoid having a resistance value or less than  $24\Omega$  to the drawer drive terminal.  
The attachment of unspecified equipment may cause breakdown of the equipment or heat damage to the solenoid, resulting in the danger of fire or electric shock.
- Do not carry out setting of the dip switches while the power plug is still plugged in to the power outlet, since this action may cause breakdowns or the danger of electric shock.
- Do not remove any screws other than the screws that fix the rear cover, since removing other screws may cause breakdowns or the danger of electric shock.



 **CAUTION**

- Do not touch the print head or motor immediately after printing, since these parts will be very hot and there will be a danger of burning your hand.

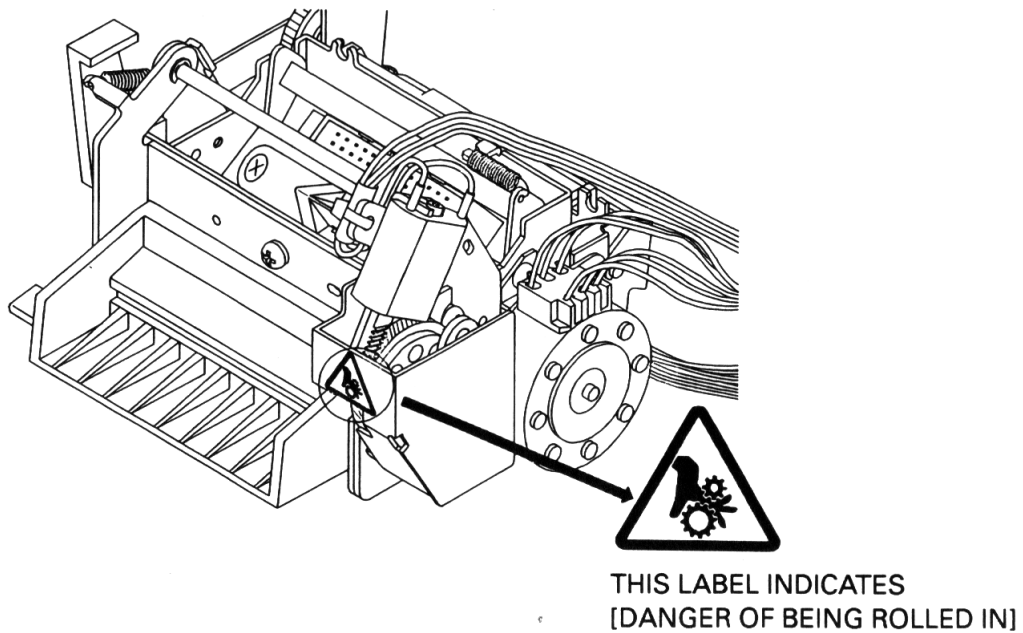
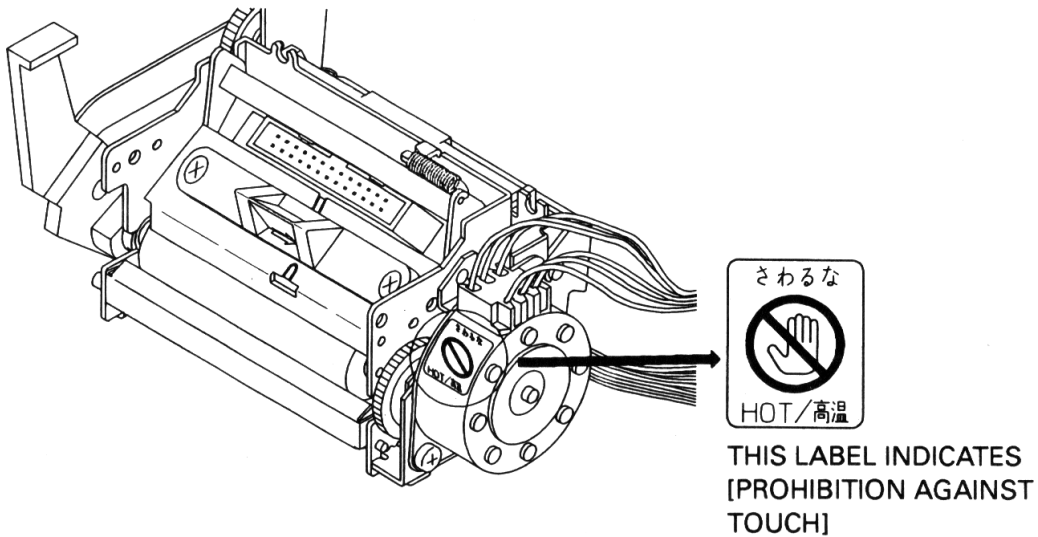

**CAUTION**

- Do not place objects on top of this equipment. since there will be a danger of the objects falling off or falling over, resulting in injury.
- Do not use or store this equipment in locations that have fire or moisture, in locations that are subject to direct sunlight, in locations that are abnormally hot such as close to heating equipment, or in locations that are very humid or dusty, since t his will be a cause of breakdowns.

## CONTENTS

<b>1.</b>	<b>OUTLINE.....</b>	<b>1</b>
1.1	Features .....	1
1.2	Cautions for installation .....	1
1.3	General cautions.....	2
<b>2.</b>	<b>BASIC SPECIFICATIONS.....</b>	<b>4</b>
2.1	Model classifications.....	4
2.2	Printing specifications.....	4
2.3	Character specifications .....	5
2.4	Paper specifications.....	8
2.5	Interfaces .....	10
2.6	Data buffer .....	10
2.7	Paper and sensor.....	10
2.8	Auto-cutter .....	10
2.9	Drawer kick-out connector.....	10
2.10	Electrical specifications .....	10
2.11	External appearance specifications .....	11
2.12	Environmental specifications .....	11
2.13	Reliability specifications .....	11
2.14	EMI standards and safety standards .....	11
<b>3.</b>	<b>EXTERNAL APPEARANCE AND NAMES OF EACH PART .....</b>	<b>12</b>
3.1	External appearance and part names .....	12
3.2	Explanation of each part .....	13
<b>4.</b>	<b>OPERATION .....</b>	<b>15</b>
4.1	Opening the printer cover .....	15
4.2	Opening the auto-cutter.....	16
4.3	Setting the paper roll in the paper holder .....	17
4.4	Loading the paper.....	18
4.5	Loading the paper when paper roll is small .....	19
4.6	Setting the printer cover back .....	22
4.7	Opening the print head.....	23
4.8	Serf-printing .....	24
4.9	Hexadecimal dumping function .....	24
4.10	Paper end detecting function.....	25

---

<b>5.</b>	<b>INTERFACE SPECIFICATIONS</b> .....	<b>26</b>
5.1	Serial interface .....	26
5.2	Parallel interface .....	28
<b>6.</b>	<b>DRAWER KICK-OUT CONNECTOR</b> .....	<b>30</b>
<b>7.</b>	<b>DIP SWITCH SETTINGS</b> .....	<b>32</b>
<b>8.</b>	<b>FUNTIONS</b> .....	<b>35</b>
8.1	Command table .....	35
8.2	Details of commands.....	37
8.2.1	How to read each section .....	37
8.2.2	Detailed explanations.....	38
8.3	Character code tables .....	106
8.3.1	Page 0 (International character set: When U.S.A characters have been selected) .....	106
8.3.2	Page 1 (International character set: When U.S.A characters have been selected) .....	107
8.3.3	International character sets .....	108
<b>9.</b>	<b>EXTERNAL DIMENSION</b> .....	<b>109</b>

## 1. OUTLINE

This printer is a thermal line printer that is capable of being widely used with various types of data communication terminals, POS terminals, or kitchen printers, etc. Because this printer uses a thermal line printing system, high speed printing is possible. Furthermore, this printer may be widely utilized for various applications due to the incorporation of ample functions.

### 1.1 Features

- Small size and light weight.
- High speed printing. (400 dot lines/second)
- Quiet operation and high reliability.
- Due to the head opening mechanism, maintenance such as head cleaning will be simple.
- RS-232C or Centronics interface are selectable.
- Bar code printing is available. (Using exclusive commands)
- The character size can be specified. (Standard size, double wide, double height, double wide and double height.)
- International character sets for 11 countries are built in.
- A drawer kick-out interface is built in.
- An auto-cutter is equipped.
- The receiving buffer size is selectable. (45 bytes or 4 K bytes.)

### 1.2 Cautions for installation

1. Concerning the use of this equipment, please carefully read the "Cautions for safe use", and carry out operations following these cautions.
2. Confirm that the accessories listed below are included in addition to the printer main unit in this set of equipment.
  - Roll of paper ..... 1 roll
  - User's manual ..... 1 manual
3. This equipment should not be operated or stored in locations that have fire or moisture, in locations that are exposed to direct sunlight, in locations that have abnormally high temperatures due to heating equipment or hot equipment, in low locations, or in locations that are very damp or dusty.
4. This equipment should not be installed in locations where chemical reactions are generated, such as in laboratories, etc.

5. This equipment should not be installed in locations where the air contains salt or toxic gases.
6. Install the printer on a flat, stable table top in a location having good ventilation. (Ensure that the ventilation holes are not blocked.)
7. Items should not be placed on top of this equipment.
8. Note that the use of this equipment close to a radio or television receiver, or sharing the same power source outlet may cause reception problems in the radio or television.
9. Only use this equipment at the specified voltage and frequency.
10. Do not place objects on top of the power cable or tread on top of the cable.
11. Do not pull or carry the main unit by holding the power cable or data cable.
12. Avoid connecting the power cable together with several other power cables to one power source outlet.
13. When pulling out the power cord, be sure to hold the plug while pulling it out.
14. Be sure to connect the connector properly. In particular, the internal terminals may be destroyed if the connector is connected using the reverse polarity.
15. Be sure to set the power switch to OFF before mounting or removing the interface connector cable.
16. As far as possible, avoid over-lengthening the signal wire or connecting the printer to equipment that generates noise. In situations where wiring of this kind must be carried out, apply adequate countermeasures such as using shielded wiring or twisted pair wiring for each signal.
17. Only connect the prescribed solenoid to the drawer kick connector.
18. Ensure that there is a power source outlet close to the equipment, and make sure that this power source outlet can be easily reached.

### **1.3 General cautions**

1. Concerning the use of this equipment, please read the "Cautions for safe use", and carry out operations following these cautions.
2. Do not carry out blank printing in the condition where there is no recording paper in the printing unit.
3. Take care not to touch the printing unit of the thermal print head with your bare hands.
4. When cleaning the head or platen, please use the exclusive cleaning kit for radio cassette recorder on the market etc.
5. When cleaning the surface of the main unit case, do not use thinners, turpentine, benzene or ketene group solvents, or chemical-impregnated cleaning cloths.
6. Avoid using this equipment in locations which are subject to large amounts of oil, iron powder, debris, dust, etc.
7. Take care not to drop paper clips, valve core pins, foreign objects, etc. into the main unit, since this will become a cause of breakdowns.

8. Do not spill liquids or spray chemicals, etc. onto this equipment.
9. Do not subject this equipment to strong shock or vibration by standing on it, dropping it, hitting it, etc.
10. Carry out the operation of the operating panel unit with care, since disordered operation will become a cause of breakdowns and mistaken operation. Furthermore, absolutely do not operate the panel using sharp objects such as the tip of a pen etc.
11. During operation, do not touch moving parts such as gears, or the electrical parts inside the main unit.
12. Take care not to injure yourself or cause damage to other objects from the edges of the sheet metal.
13. If an abnormality occurs during use, immediately stop using the printer and remove the power cable from the power source outlet.
14. If a breakdown occurs, do not attempt to disassemble the equipment. Be sure to leave the repair of this equipment to Service personnel.

## 2. BASIC SPECIFICATIONS

### 2.1 Model classifications

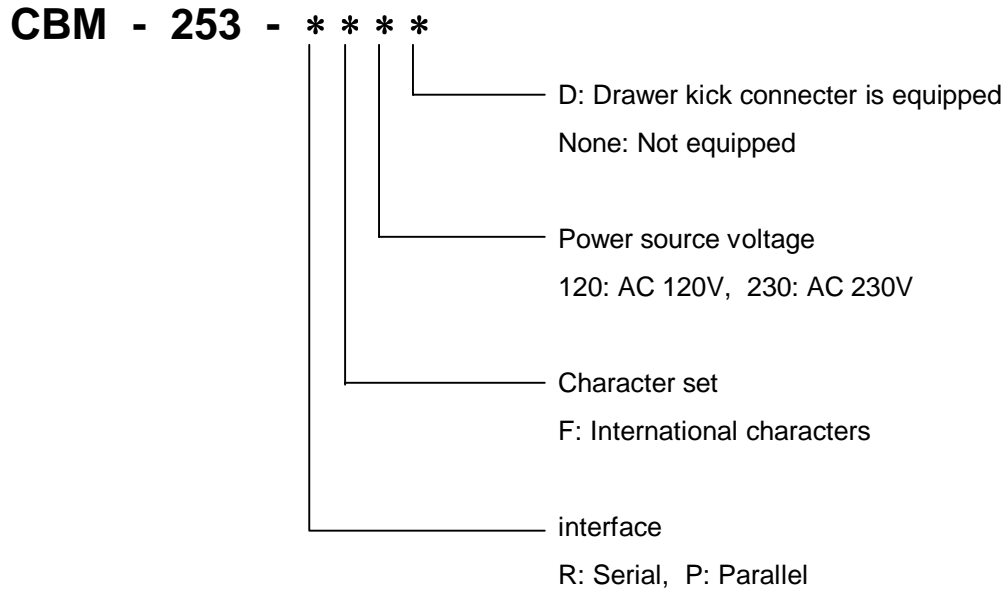

### 2.2 Printing specifications

Printing method	Direct heat coloring system (Direct thermal)
Printing direction	Line feeding by friction feeding
Effective printing area	Effective Printing width: 56mm 448 dots/line (Thermal paper) 53mm 424 dots/line (Thermal label paper)
Dot density	Main scanning line density: 8 dots/mm. (203 dpi)
Number of columns	37 columns (Font 1 , Thermal paper) 49 columns (Font 2, Thermal label paper) 35 columns (Font 1, Thermal paper) 47 columns (Font 2, Thermal label paper)



Printing speed	400 dot lines/second (Approximately 11 lines/second when the line feeding amount is 1/6 inch.) However, depending on the combination of the communication time, data, and control codes, the printing speed may be slower.
Paper feeding speed	50 mm/second (Approximately 11 lines/second when the line feeding amount is 1/6 inch.)
Line feeding pitch	1/6 inch (Default value) Possible to change the pitch using the control codes (Minimum width 1/203 inch)

### 2.3 Character specifications

Character types :	Alphanumeric characters      95 characters International characters      32 characters
Character configuration	12 × 24    (Font 1 including 2-dot horizontal spacing) 9 × 17     (Font 2 including 2-dot horizontal spacing) Font 1 is selected as the default.
Character size	1.25 × 3.0 (mm)    (Font 1) 0.88 × 2.13 (mm)   (Font 2)
Character enlargement rates	Standard size, double wide, double height, double wide and height









## Number of columns

	Standard size	Double height	Double wide	Double wide and height
Font 1	37	37	18	18
	35	35	17	17
Font 2	49	49	24	24
	47	47	23	23

(Spaces between the characters are not included)

The figures on the top line show the situation when thermal paper is selected, and the figures on the bottom line show the situation when thermal label paper is selected.

Available bar codes                      UPC-A, UPC-E, JAN- 13 (EAN), JAN-8 (EAN), CODE 39, ITF, CODABAR, CODE 128

Type	Printing samples	Features
UPC-A		This is a fixed-length bar code that is composed of 12 figures of numerals only.
UPC-E		This is a fixed-length bar code that is composed of 8 figures of numerals only. This bar code is a shortened version of UPC-A.
JAN- 13		This is a fixed-length bar code that is composed of 13 figures of numerals only.
JAN-8		This is a fixed-length bar code that is composed of 8 figures of numerals only.
CODE 39		This is a variable-length bar code that is composed of alphabetic characters and numerals. The start and stop '*' characters are attached automatically.
ITF		This is an even-numbered variable-length bar code that is composed of numerals only.
CODABAR		This is a variable-length bar code that is composed of alphabetic characters. For the start and stop characters, one of 'abcd' is required.
CODE 128		This is a variable-length bar code that is composed of any of the 128 ASCII code characters.

Bar code specification                      Type/number of printing figures/bar code height/horizontal width (enlargement) / presence of visible code Printing will be carried out according to the bar code data specifications.

## 2.4 Paper specifications

Specified paper (Roll paper)

Thermal paper

Paper width	: 60.0 mm $\pm$ 0.1mm
Paper thickness	: 65 $\pm$ 5 $\mu$ m
Diameter of paper roll	: $\phi$ 83 mm maximum
Recommended paper	: TF50KS-EY Nihon Seishi Co., Ltd. : TF50KS-E2C Nihon Seishi Co., Ltd.
Roll paper core	: Internal diameter $\phi$ 12.0 mm : External diameter $\phi$ 18.0 mm

\* Absolutely do not stick the paper to the core.

\* The printing surface should be outside.

Printing area

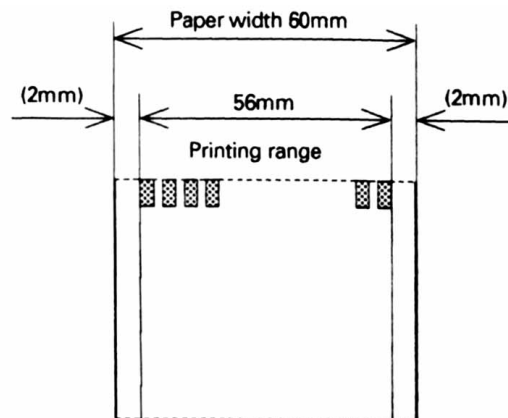

Thermal label paper

Paper width	: 60.0 mm $\pm$ 0.1mm
Paper thickness	: 150 $\mu$ m maximum (Base paper thickness + Label thickness)
Diameter of paper roll	: $\phi$ 83 mm maximum
Label size	: Minimum 25 mm ~ maximum 100 mm
Recommended paper	: HG76, HD75 Nihon Seishi Co., Ltd.
Roll paper core	: Internal diameter $\phi$ 25.4 mm : External diameter $\phi$ 33.4 mm

\* Absolutely do not stick the paper to the core.

\* The printing surface should be outside.

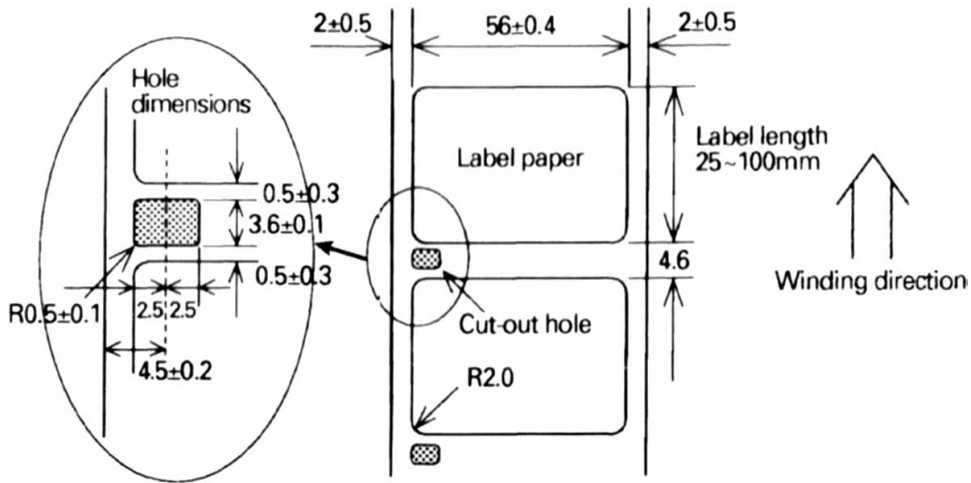

- In order to allow the detection of the paper label length and label top position, cut-out holes should be made between the paper labels according to the dimensions shown above.
- Do not use label paper that has different dimensions from that shown above.

Printing area

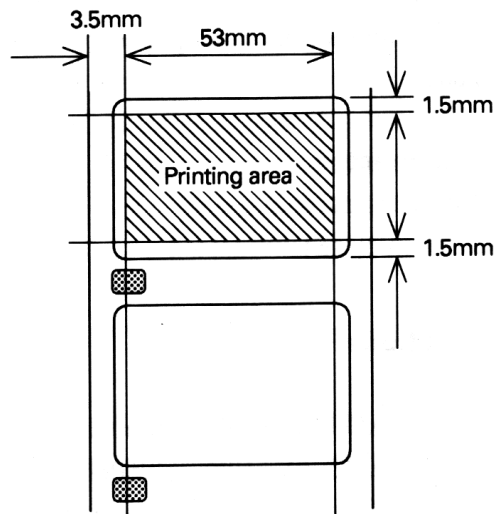

Note: Do not mix labels having different widths and length in the same roll of label paper.

Note : Have a surplus in the printing range in consideration of the flexing and the range of differences in the printing paper.

## 2.5 Interfaces

Serial interface (RS-232C)

Parallel interface

## 2.6 Data buffer

4KB or 45B (Selectable by dip switch setting)

## 2.7 Paper and sensor

Detection of whether there is paper or not. (Mechanical unit)

Near-end detection (Paper holder unit)

## 2.8 Auto-cutter

Rotary system, full cut type (AC-7)

Note: Auto-cutter operation will not be possible while the printer is printing.

Note: After switching on the printer, carry out cutting one time in order to determine the position.

Note: In case of using thermal label paper, paste of label may stick to cutter blade.

## 2.9 Drawer kick-out connector

Drawer kick-out drive terminal × 2

Detection of drawer open/close terminal × 1

## 2.10 Electrical specifications

Power source voltage	AC 120V+10% 50/60Hz AC 230V+10% 50/60Hz (Selected according to the product destination)
Power cable	For North America: 3-pin UL cable For Europe: 3-pin Class 1 cable
Power consumption	Approximately 20W (during character printing) Approximately 40W (during full printing)

## 2.11 External appearance specifications

Weight                      Approximately 2.2kg

External dimensions Refer to 'External dimensions' at the end of this manual.

## 2.12 Environmental specifications

Temperature	Operating temperature	5°C~40°C
	Storage temperature	-10°C~50°C (Excluding the recording paper)
Humidity	Operating humidity	35~80% (Non-condensing)
	Storage humidity	30~90% (Non-condensing, excluding the recording paper)

## 2.13 Reliability specifications

Head lifetime	Pulse resistance	: $5 \times 10^7$ pulses
	Wear resistance	: 30 km

(At a printing rate of less than 25.0%, with a resistance value change rate of 15% or less.)

Cutter lifetime            500,000 cuts (At no paste of label on cutter blade.)

Please note that the above lifetime is not guaranteed value.

This value may change depending on installation environment of printer unit.

## 2.14 EMI standards and safety standards

FCC	Class A
VCCI	Type 1
UL	1950
EN	60950

### 3. EXTERNAL APPEARANCE AND NAMES OF EACH PART

#### 3.1 External appearance and part names

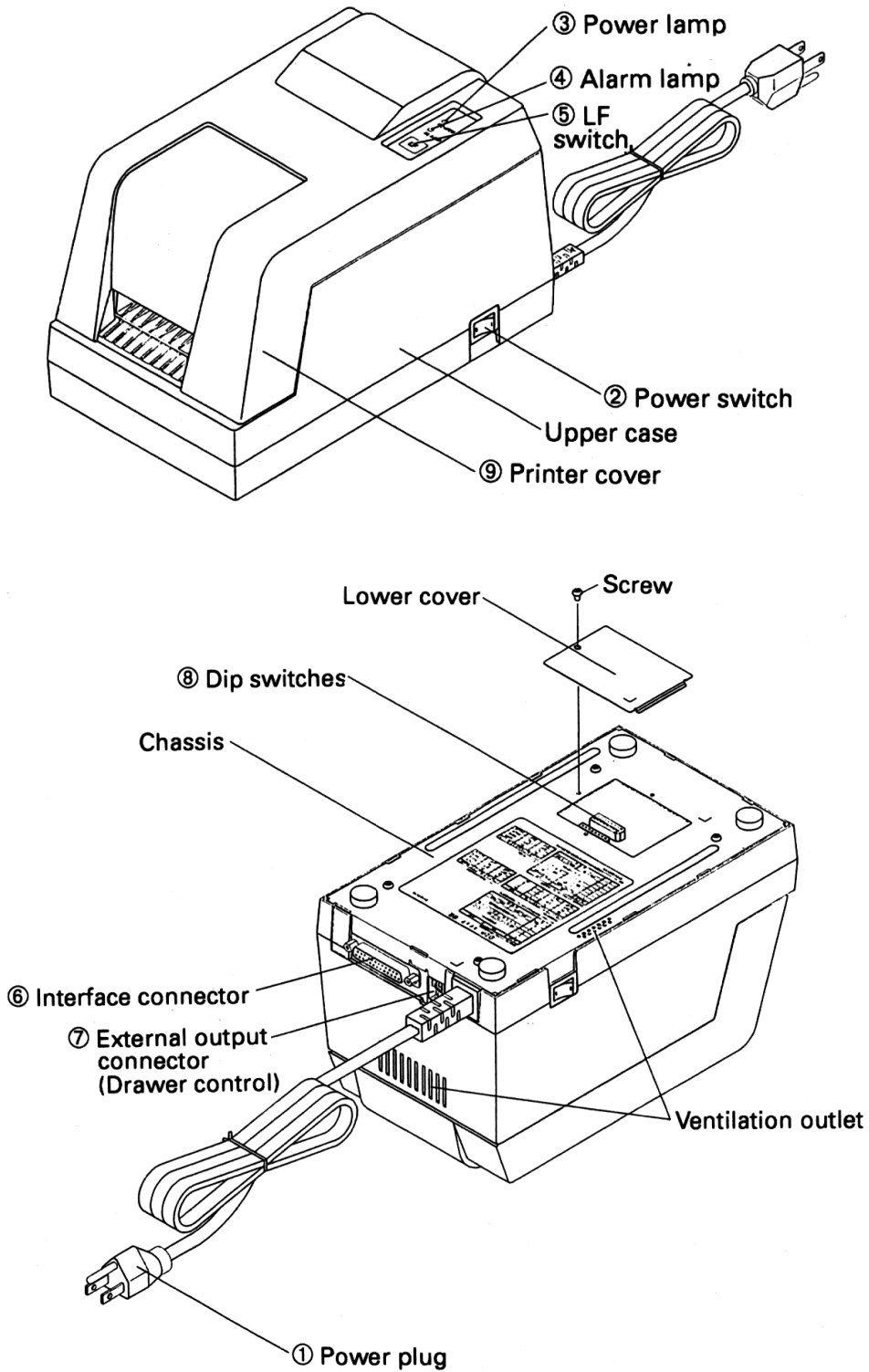







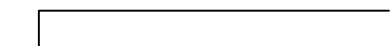

### 3.2 Explanation of each part

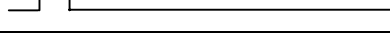
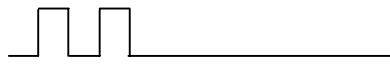
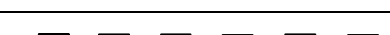
- ① Power plug                      This plug should be inserted into a power source outlet of the specified voltage.
  
- ② Power switch                    By setting this switch to ON, the printer initialization operation will begin.
  
- ③ Power lamp                      This lamp will be lit when the power switch is ON, and will be off when the power switch is OFF.
  
- ④ Alarm lamp                      This lamp will light in the printer error condition. The lamp will flash to indicate the printer condition during errors such as when the paper has run out, when the head is open, or when the head is overheating, and will also flash when the printer is in the condition of waiting for macro execution, etc.

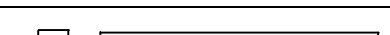
#### Error display patterns

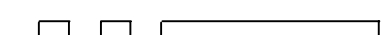
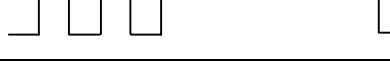
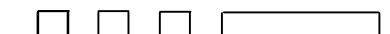
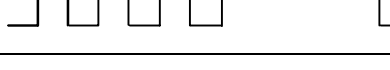
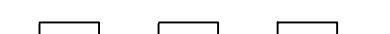
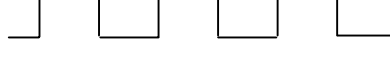
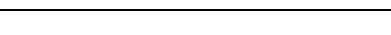
Error name	Pattern of flashing	Conditions for resetting
Printer cover open Head up Paper near-end	Lit  Off 	Close the cover Head down Set the paper
Paper end	Lit  Off 	Set the paper
Label detecting error	Lit  Off 	Set the specified label paper and then switch the power on a again
Memory checking error	Lit  Off 	Resetting not possible *1
Head thermistor error	Lit  Off 	Resetting not possible *1
Head overheating	Lit  Off 	Automatic resetting when the temperature lowers
Cutter motor locking	Lit  Off 	Resetting not possible *1
Waiting for macro execution Waiting for label ejection Waiting for test printing Waiting for cutter operation	Lit  Off 	Press the LF switch

\* 1 Contact service person.

- ⑤ LF switch                      Pressing this switch carries out line feeding of the paper. When the printer is waiting for macro execution, pressing this switch will carry out the execution. When the power switch is switched on while this switch is being pressed, self-printing will be carried out.
- ⑥ Interface connector              This interface allows connection with various types of personal computers using a cable. When making the connection, the power of the personal computer and the printer should be switched off.
- ⑦ External output connector      This connector is used for control of the drawer.
- ⑧ Dip switches                      These switches set the various functions.
- ⑨ Printer cover                      This cover should be opened and closed when replacing the printing paper.

## 4. OPERATION

### 4.1 Opening the printer cover

The printer cover may be opened by inserting your hand into the paper outlet of the printer and lifting up the cover in the direction shown by the arrow in the figure.

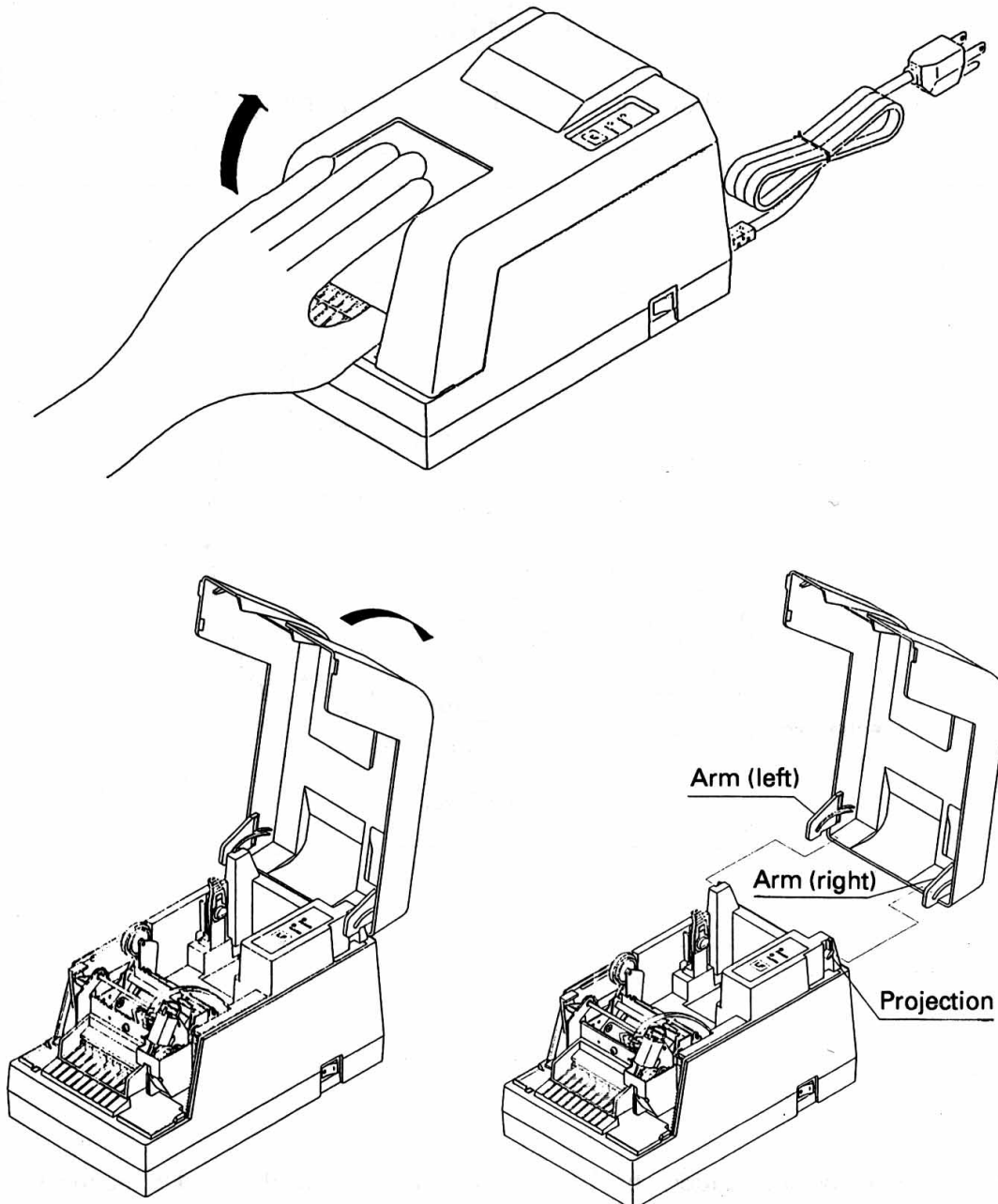

## 4.2 Opening the auto-cutter

To open the auto-cutter when the paper has become jammed in the printer or when the head is to be cleaned, lift up the auto-cutter while lifting the cutter locking lever in the direction shown by the arrow.

### CAUTION

- Do not touch the head or motor immediately after printing, since these parts will be very hot and there will be a danger of burning your hand.

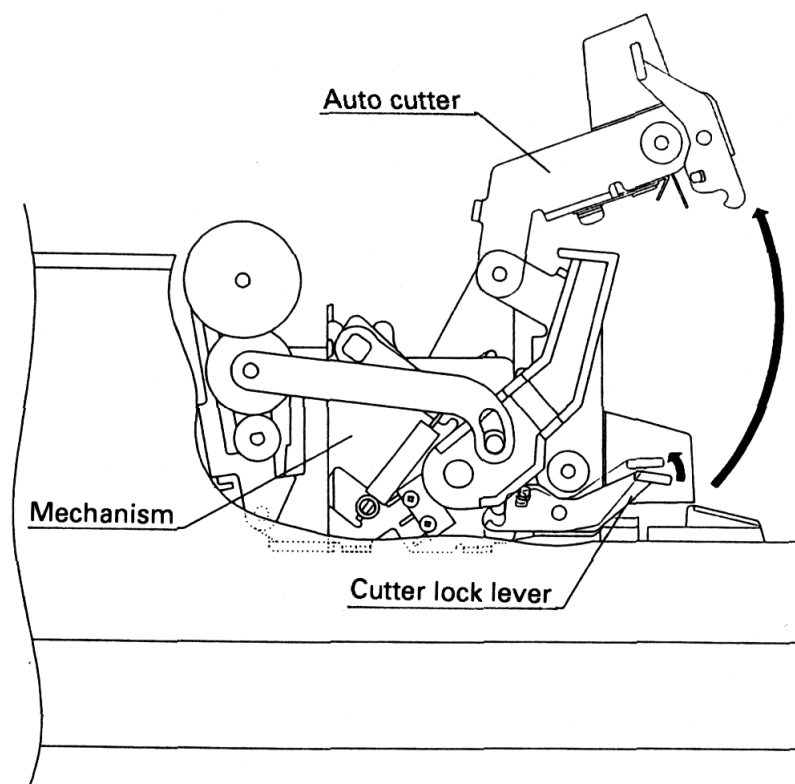

After closing the auto-cutter, check that the cutter unit is firmly fixed in the mechanism by the cutter locking lever. If the cutter unit is not firmly fixed, this will become a cause of paper jamming.

### 4.3 Setting the paper roll in the paper holder

Open the paper holder in the direction shown by the arrow and set the roll paper.

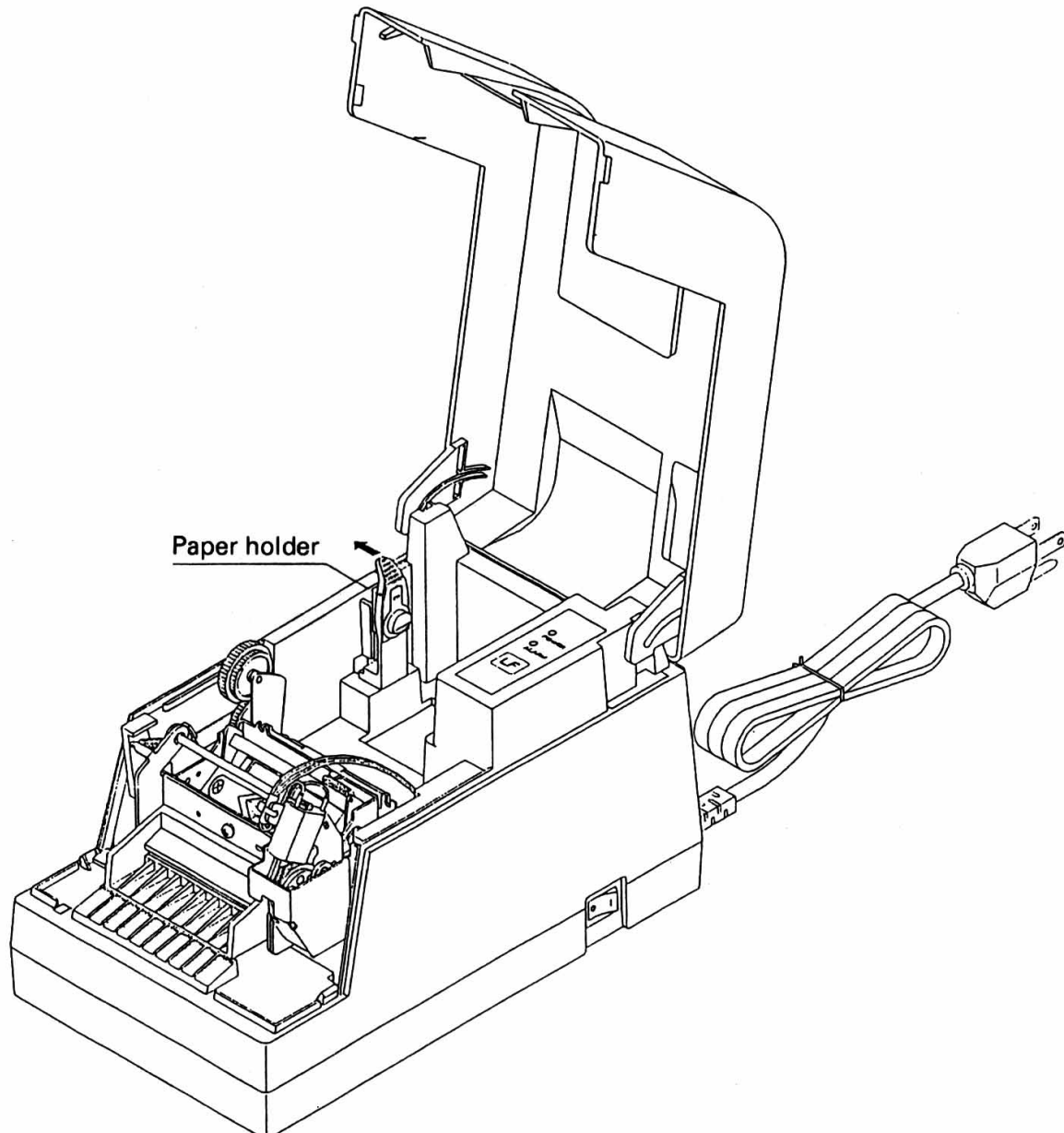

#### 4.4 Loading the paper

1. Open the printer cover.
2. Cut the end of the roll of paper at right angles as shown in the figure.

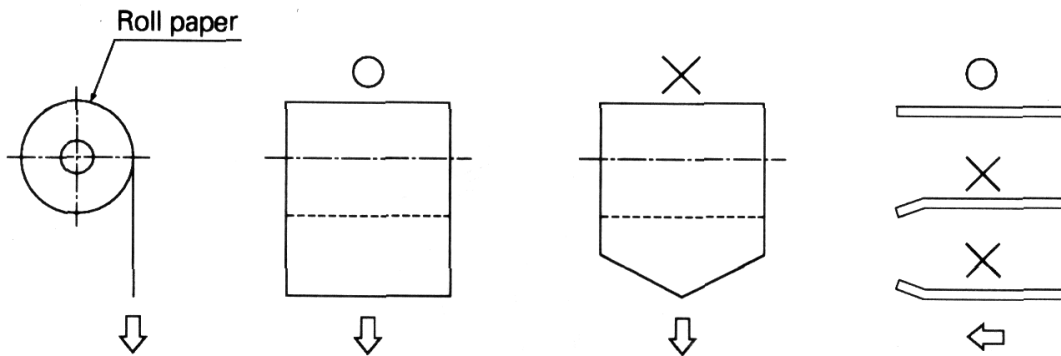

3. Set the printing paper in the paper holder as shown in the figure.

\* Make sure that the paper roll rotates smoothly.

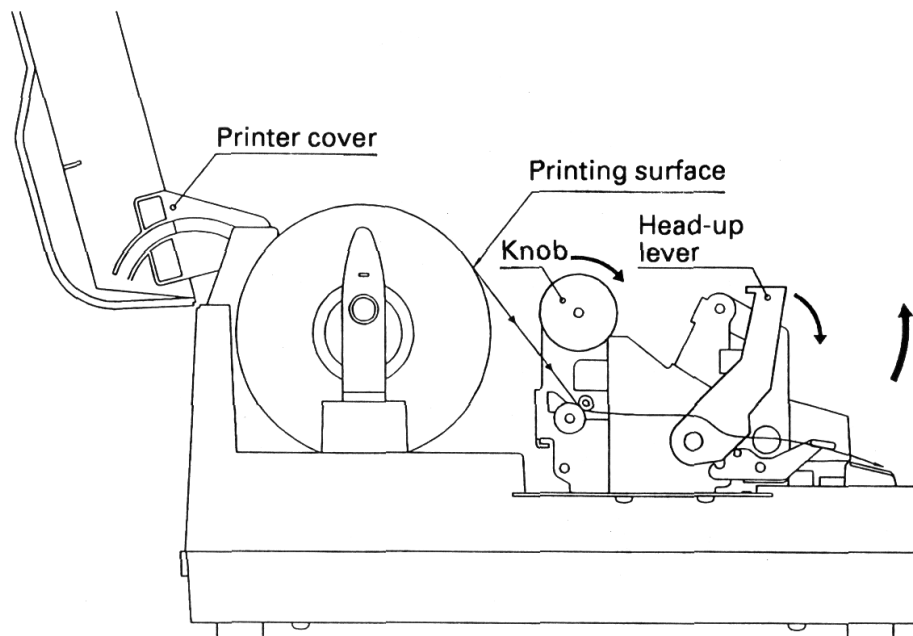

4. Make sure the winding direction of the paper roll is correct, then insert the end of the printing paper into the paper inlet in the rear part of the printer. (Printing surface should be outside.)
5. Open the head-up lever (press it down forwards) to set the head up condition.
6. Use the knob to feed the printing paper up to the paper outlet.
7. Close the head-up lever. (Lift up the lever)
8. Close the printer cover.

## 4.5 Loading the paper when paper roll is small

### ! CAUTION

- Do not touch the head or motor immediately after printing, since these parts will be very hot and there will be a danger of burning your hand.

- Open the printer cover.
- Cut the end of the roll of paper at right angles as shown in the figure.

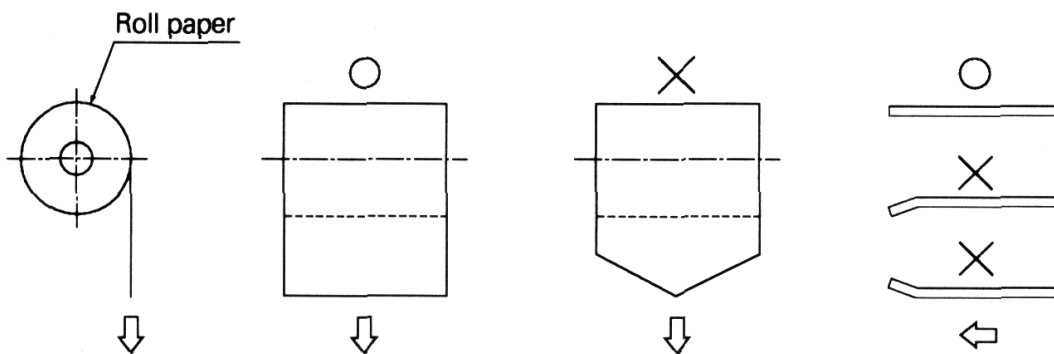

- Set the printing paper in the paper holder as shown in the figure.

\* Confirm that the paper roll rotates smoothly.

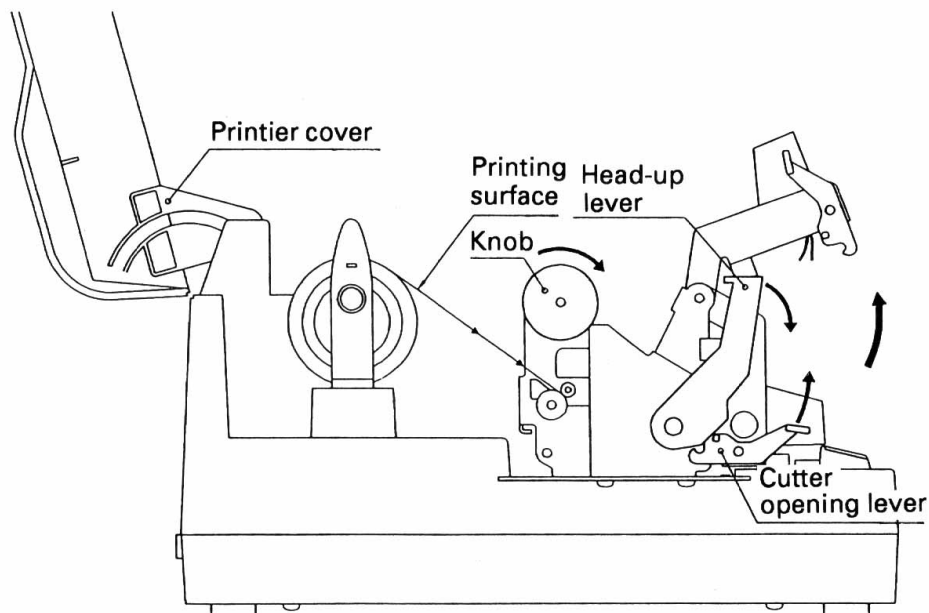

4. Lift up the auto-cutter lever to open the cutter.
5. Confirm the winding direction of the paper roll, then insert the end of the printing paper into the paper inlet in the rear of the printer. (Note that printing surface should be outside.)
6. Open the head-up lever (press it down forwards) to set the head-up condition.
7. Using the knob, feed the printing paper until the paper comes out of the printer mechanism.



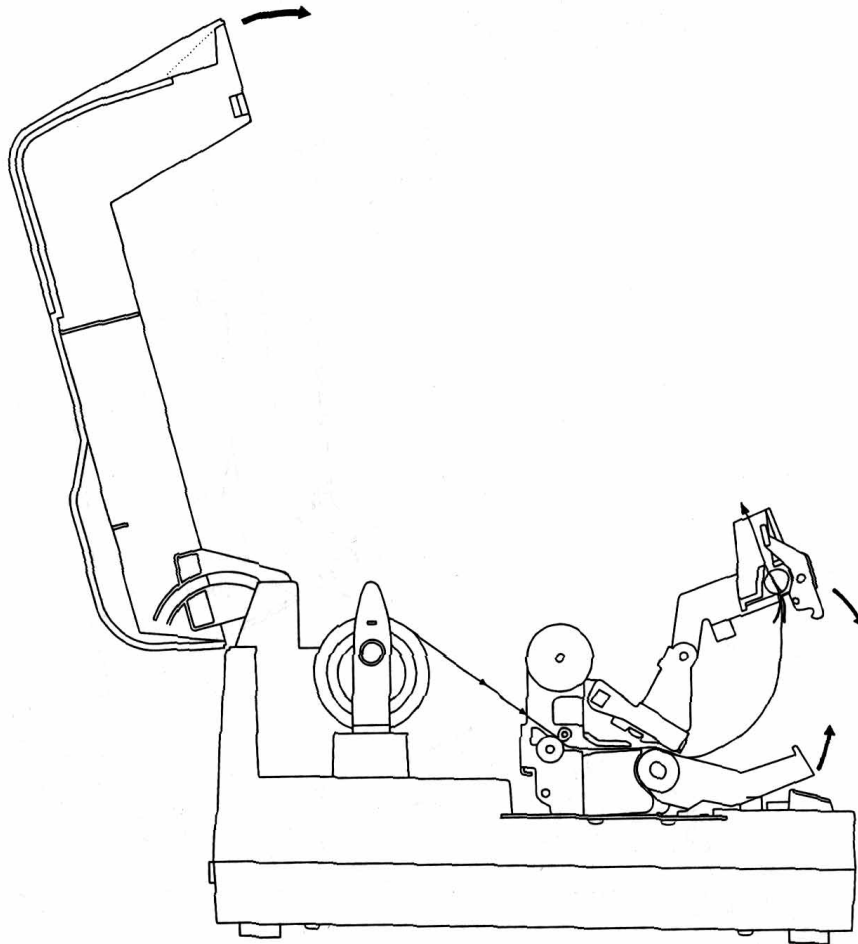

8. Pull the paper that has come out of the printer mechanism and pass it through the autocutter.
9. Close the auto-cutter while pulling the end of the paper that has passed through the auto-cutter.
10. Close the head-up lever.
11. Close the printer cover.

#### 4.6 Setting the printer cover back

Holding the printer cover in the approximately 90° open position, hook the right arm onto the right boss. Then while pulling open the left arm, hook it on to the left boss to complete the mounting of the printer cover.

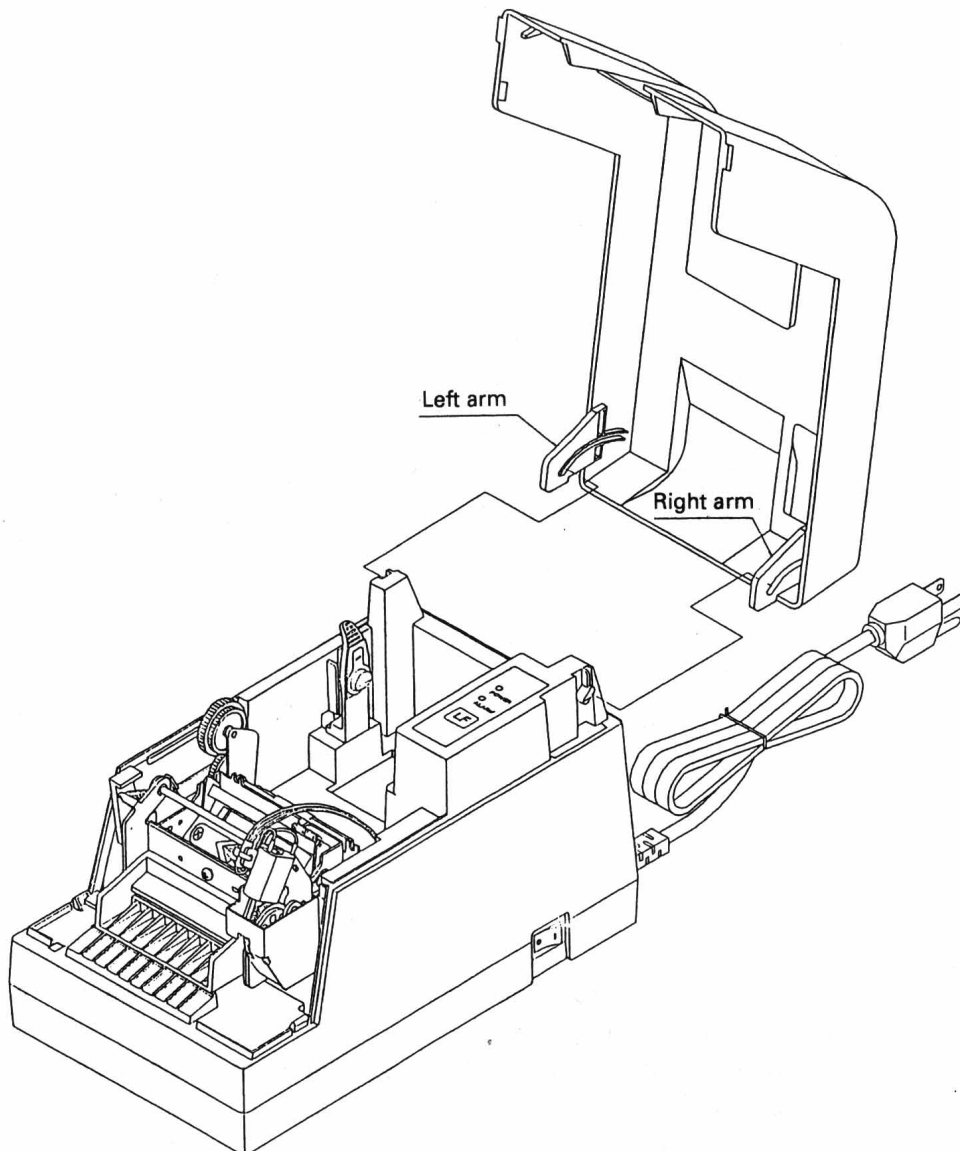

## 4.7 Opening the print head

### CAUTION

- Do not touch the head or motor immediately after printing, since these parts will be very hot and there will be a danger of burning your hand.

1. Switch OFF the power switch. and remove the power plug from the mains outlet.
2. As shown in the figure, open the printer cover and the auto-cutter and then press the head-up lever down forwards.
3. While sliding the head opening knob in the direction shown by ① in the figure, lift up the head in the direction shown by ② in the figure to open the head.

Note: This operation should only be carried out when cleaning the head or platen.

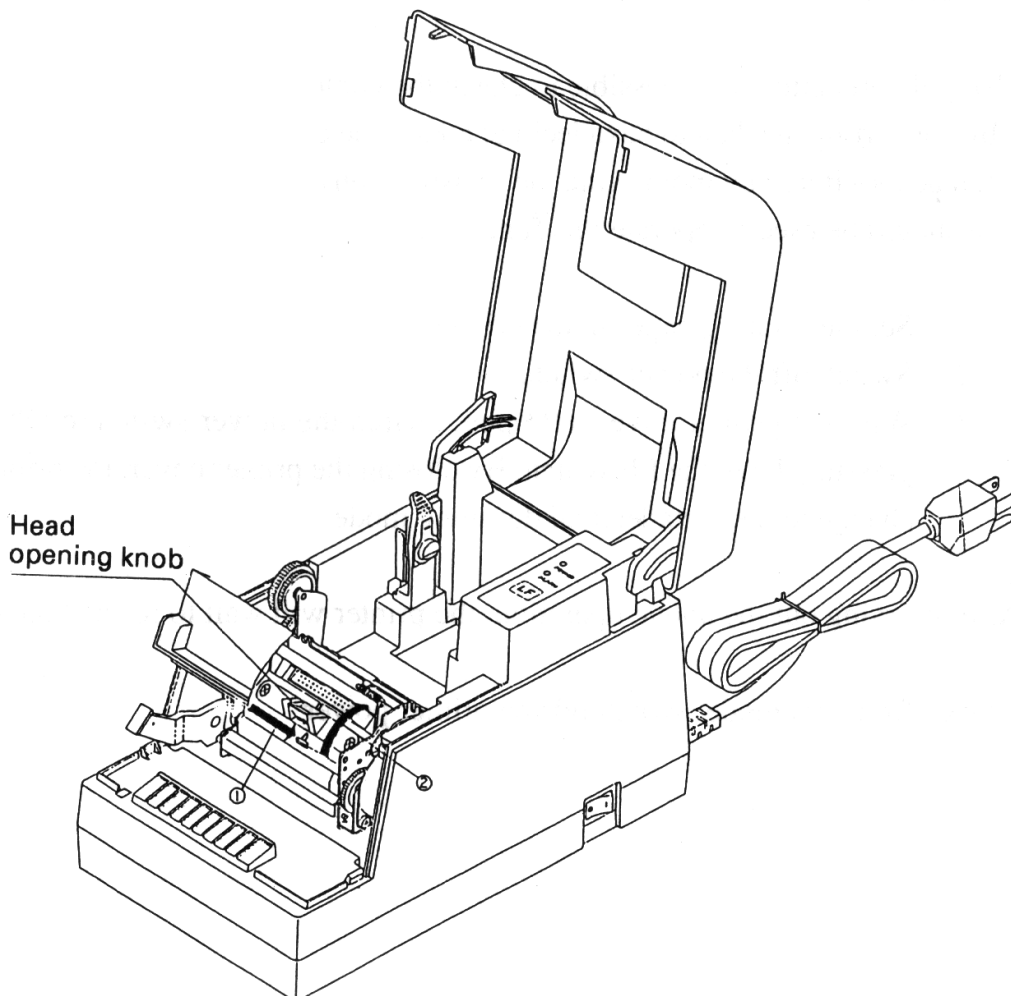

## 4.8 Self-printing

A self-printing function is built in to this printer in order that the printing functions may be checked by the printer itself. The following procedure should be used to operate this function:

1. Set the printing paper in the printer.
2. Switch off the power switch.
3. Close the printer cover and then switch the power switch to ON while pressing down the LF switch. Stop pressing the LF switch after confirming that the self-printing has started.

The printing will be started by the above operation, and the printer will change back to the normal mode after completion of the fixed line printing.

## 4.9 Hexadecimal dumping function

Using this function, it is possible to check the contents of data sent from the host unit by convening the data to hexadecimal code. The data transmission with the host unit can be monitored by monitoring the transmission conditions. The following procedure should be used to operate this function:

1. Set the printing paper in the printer.
2. Switch off the power switch.
3. With the printer cover left open, switch the power switch to ON while pressing down the LF switch. By closing the printer cover, the printer will change to the hexadecimal dumping mode.

After carrying out the above operation, the printer will wait to receive the data.

To exit from this mode, switch off the printer power.

#### **4.10 Paper end detecting function**

This printer includes functions that automatically detect when the remaining printing paper is running low and stop the printing. The paper end detecting function detects when the paper has run out, and the paper near-end detecting function detects when the remaining printing paper is running low.

The switching of the paper near-end detecting function between enabled and disabled is carried out using the <ESC c 4> command. When this function is set to enabled, the setting of the paper length that is allowed between the occurrence of the detection and the stopping of the printing should be carried out using the dip switches.

Note : In a situation in which the paper end is detected while printing on label paper, the data remaining in the receiving buffer may not be printed at the intended position on the label.

## 5. INTERFACE SPECIFICATIONS

### 5.1 Serial interface

Specifications (Conform to RS-232C)

Synchronizing system : Asynchronous system  
 Handshaking : DTR/DSR control or Xon/Xoff control  
 Baud rates : 1200, 4800, 9600, 19200 (Selected by the user)  
 Data length : 7 or 8 bit length (Selected by the user)  
 Parity : Odd/Even/None (Selected by the user)  
 Signal level : Mark= -3 ~ -15V Logic '1'  
 : Space = +3 ~ +15V Logic '0'

Compatible interface connectors

Printer side : 25-pin connector 17-13250 (DDK) equivalent product  
 Cable side : 25-pin connector 17-23250 (DDK) equivalent product

Connector's pin configuration

Connector pin	Signal name	Input/output	Function
1	FG	–	Frame ground
2	TxD	Output	Sending data
3	RxD	Input	Receiving data
6	DSR	Input	Data set ready
20	DTR	Output	Data terminal ready
7	SG	–	Signal ground

Note: Shielded type cables should be used.

Explanation of input and output signals

(1) RxD

This is the serial receiving data signal. On the occurrence of framing errors, overrun errors or parity errors, this data will either be rejected or printed as ' ? '. according to the DSW2-7 switch condition.

(2) DTR

When the DTR/DSR control has been selected, data or commands should be written when this signal is at ready. If writing is carried out while this signal is at BUSY, an overrun error will occur and the data will be ignored. Data can be written into the input buffer even when printing is being carried out.

(3) TxD

When receiving data while using Xon/Xoff control, an Xoff (13H) 'Data receiving not possible' signal will be output when the remaining space of the input buffer inside the printer becomes less than 10 bytes. When the input buffer remaining space become more than 20 bytes, an Xon (11H) 'Data receiving possible' signal will be output. When sending status information while the DTR/DSR control is selected, confirm that the DSR is at 'space' before sending the data. In the Xon/Xoff control, the data should be sent regardless of the DSR condition.

(4) FG

This is a frame ground.

(5) SG

This is the common ground on the circuit board.

Receiving control

When DTR/DSR control has been selected, data will be received from the host when the DTR signal is at 'space'. Data receiving will not be possible when the DTR signal is at 'mark'.

When Xon/Xoff control has been selected, data will be received from the host side after the Xon signal has been sent. However, data receiving will not be possible after the Xoff signal has been sent.

## 5.2 Parallel interface

### Specifications (Conform to Centronics)

Data transmission format	: 8-bit parallel
Synchronizing system	: According to the strobe pulses
Handshaking	: According to the BUSY signal
Signal level	: TTL level

### Compatible interface connectors

Printer side	: Ribbon connector	57-40360 (DDK) equivalent product
Cable side	: Ribbon connector	57-30360 (DDK) equivalent product

### Connector's pin configuration

Connector pin	Signal name	Input/output	Function
1	*STB	Input	Strobe signal
2~9	DATA 1-8	Input	Input data
10	*ACK	Output	Request for next data
11	BUSY	Output	Processing is taking place
12	PE	Output	Paper end
13 (See note)	+5V	Output	+5V DC
14-15	N/C		
16	GND		Ground
17	FG		Frame ground
18	N/C		
19-30	GND		Twisted pair return signals
31	*RESET	Input	Reset
32	*FAULT	Output	Error
33	GND		Ground
34	COMPULSION	Output	COMPULSION signal
35 (See note)	+5V	Output	+5V DC
36	N/C		

The \* mark represents a negative logic.

N/C means not connected.

Note: Shield type cables should be used.

Note: Pins 13 and 35 can not be used by the user (Pulled up by 3.3K )



### Explanation of input and output signals

#### (1) Input signals

- DATA 1~8 : 8-bit parallel signals (Positive logic)
- \* STB : Strobe signal used when reading in 8-bit data (Negative logic)
- \* RESET : Signal that reset the whole printer. (Negative logic)

#### (2) Output signals

- \* ACK : This is an 8-bit data requesting signal that is output as a BUSY FAULT PE pulse signal at the end of the BUSY signal. (Negative logic)
- BUSY : This signal indicates that the printer is in the BUSY condition. New data should be input when this signal is LOW. (Positive logic)
- FAULT : This signal changes to LOW when the printer is in the alarm condition. At this time, all of the control circuits in the printer will stop. (Negative logic)
- PE : This signal will be output when the printing paper runs out or runs low. (Positive logic)
- COMPULSION : This signal outputs the drawer switch condition. When the switch is open, the signal will be 'H' , and when the switch is shorted. the signal will be 'L' .

#### (3) Other signals

- +5V : GND N/C This is a +5V output that has been pulled-up by a 3 .3K resistance.
- GND : This is the common ground on the circuit.
- N/C : These pins are not connected.

### Receiving control

When the BUSY signal is LOW, it will be possible to receive data from the host. When the BUSY signal is HIGH, data receiving will not be possible.

## 6. DRAWER KICK-OUT CONNECTOR

(1) Drawer kick drive signal

The specified pulse will be output according to the specified pulse generating command (ESC <p>). When using the parallel interface, it will be possible to determine the condition of the drawer opening and closing switch from pin 34 of the interface connector. When using the serial interface, the switch condition may be determined by utilizing the peripheral equipment status sending command (ESC <u>).

(2) Electrical characteristics

Driving voltage : DC 24V

Driving current : Maximum 1A (Should be less than 510 ms)

SW signal : Signal level 'L' = 0~0.5V  
'H' = 3~5V

(3) Connector's pin configuration

Connector pin	Signal name	Input/Output	Function
1	FG	-	Frame ground
2	L1	Output	Drawer 1
3	SW	Input	Drawer opening and closing switch (*1)
4	Vp	-	Driving power source
5	L2	Output	Drawer 2
6	GND	-	Signal ground

Used connector 285D-3660J- 100 (DDK)

Suitable connector 285D- 1660P-I06 (DDK) equivalent product

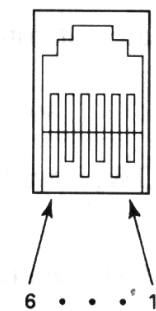

Note: It will not be possible to switch both drawer 1 and 2 to ON at the same time.

Note: Drawer operation will not be possible while the printer is printing.

Note: The duty should be kept to 20% or less.

Note: This connector is not to be used for connection to telephone lines.

**! WARNING!**

- Do not attempt to attach anything other than a solenoid, or to attach a solenoid having a resistance value of less than  $24\Omega$  to the drawer drive terminal. The attachment of unspecified equipment may cause breakdown of the equipment or heat damage to the solenoid, resulting in the danger of fire or electric shock.

(\*1) Drawer opening and closing switch signal

This signal is pulled-up inside the printer using a resistance of  $47K\Omega$ .

(4) Driving circuit (Inside of printer)

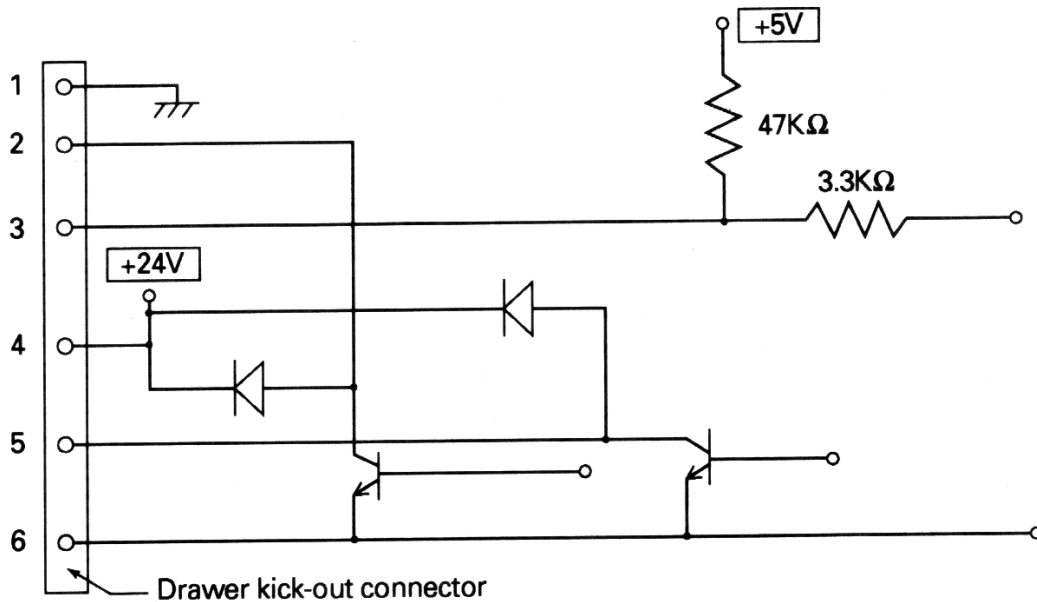

## 7. DIP SWITCH SETTINGS

The dip switches can be found inside the printer unit by removing the lower cover on the base chassis part. If the screw of the lower cover is removed, it will be possible to change the dip switch settings.

### **WARNING!**

- Do not carry out setting of dip switches while the power plug is still plugged in to the power outlet, since this action may cause breakdowns or the danger of electric shock. Do not remove any screws other than the screws that fix the rear cover, since removing other screws may cause breakdowns or the danger of electric shock.

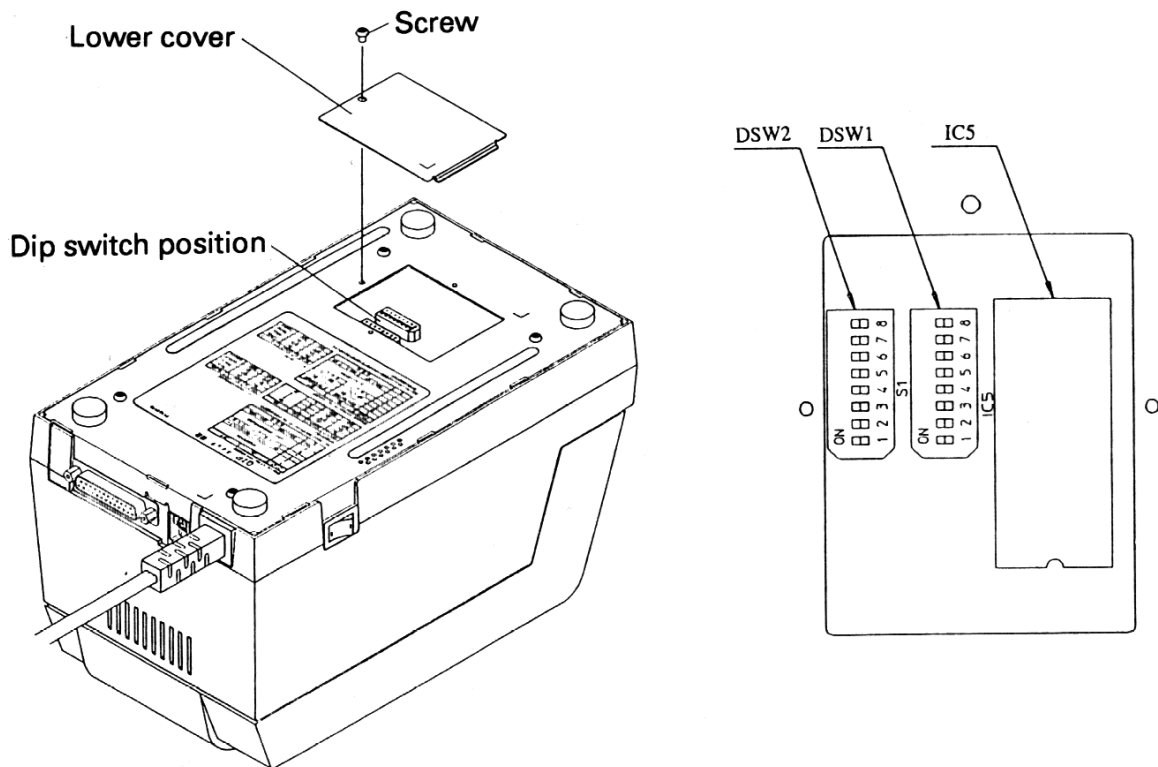

① DSW1 (Used commonly by the serial and parallel interfaces)

DSW1	ON	OFF
1	Printing density (Refer to the table below.)	
2		
3	45 byte buffer	4K byte buffer
4	Thermal label paper	Thermal paper
5	Printing stopping position after near-end detection	
6		
7 (See note 1)	CR code valid	CR code invalid
8	Spare	

Note 1 : The DSW1-7 function is only used for parallel interfaces.

Printing density

DSW 1-1	DSW1-2	Level	Density
ON	ON	1	Light   Dark
OFF	ON	2	
ON	OFF	3	
OFF	OFF	4	

Printing stopping position setting after paper near-end detection when the paper near -end detection has been enabled.

DSW1-5	DSW 1-6	Stopping position
ON	ON	0cm
OFF	ON	50cm
ON	OFF	100cm
OFF	OFF	200cm

② DSW2 (Only mounted in serial interface printers)

DSW1	ON	OFF
1	Xon/Xoff control	DTR/DSR control
2	Parity enabled	No parity
3	Even parity	Odd parity
4	7 bits	8 bits
5	Baud rate (Refer to the table below.)	
6		
7	Data rejected during a receiving error	'?' character printed during a receiving error
8	Spare	

Baud rate

DSW2-5	DSW2-6	Baud rate
ON	ON	1200
OFF	ON	4800
ON	OFF	9600
OFF	OFF	19200

Note 2 : The dip switch setting only become valid at the time when the power is switched on. According, if the setting are changed when the power is on, the switching will not be effective.

## 8. FUNCTIONS

### 8.1 Command table

Command	Function	Code	Reference page
HT	Horizontal tab command	09 <sub>H</sub>	38
LF	Printing, and paper line feeding	0A <sub>H</sub>	39
FF	Printing, and moving to the top of the label	0C <sub>H</sub>	39
CR	Printing command	0D <sub>H</sub>	41
ESC SP	Setting of the amount of space to the right of the character	1B <sub>H</sub> 20 <sub>H</sub> n	42
ESC !	Block setting of the printing mode	1B <sub>H</sub> 21 <sub>H</sub> n	43
ESC %	Specifying/releasing of the downloading character set	1B <sub>H</sub> 25 <sub>H</sub> n	44
ESC &	Defining of downloading characters	1B <sub>H</sub> 26 <sub>H</sub> s n m [a pl p2 · · · ps × a] m-n+1	46
ESC *	Specifying of the bit image mode	1B <sub>H</sub> 2A <sub>H</sub> m n1 n2[d] k	48
ESC	Specifying/releasing of the underlining	1B <sub>H</sub> 2D <sub>H</sub> n	50
ESC 2	Setting of the 1/6 inch line feeding amount	1B <sub>H</sub> 32 <sub>H</sub>	51
ESC 3	Setting of the line feeding amount in minimum paper feeding pitch units	1B <sub>H</sub> 33 <sub>H</sub> n	52
ESC =	Data input control	1B <sub>H</sub> 3D <sub>H</sub> n	53
ESC @	Printer initialization	1B <sub>H</sub> 40 <sub>H</sub>	54
ESC D	Setting of the horizontal tab positions	1B <sub>H</sub> 44 <sub>H</sub> [n]k 00 <sub>H</sub>	55
ESC E	Specifying/releasing of the highlighting	1B <sub>H</sub> 45 <sub>H</sub> n	56
ESC G	Specifying/releasing of the double printing	1B <sub>H</sub> 47 <sub>H</sub> n	57
ESC J	Printing, and paper feeding in minimum pitch units	1B <sub>H</sub> 4A <sub>H</sub> n	58
ESC R	Selection of international characters	1B <sub>H</sub> 52 <sub>H</sub> n	59
ESC V	Specifying/releasing of 90° right turned characters	1B <sub>H</sub> 56 <sub>H</sub> n	60
ESC a	Selection of printing position justification	1B <sub>H</sub> G1 <sub>H</sub> n	61
ESC c 3	Selection of the effective paper end detector for output of the paper end signal	1B <sub>H</sub> 63 <sub>H</sub> 33 <sub>H</sub> n	62
ESC c 4	Selection of the effective paper end detector for stopping the printing	1B <sub>H</sub> 63 <sub>H</sub> 34 <sub>H</sub> n	64
ESC c 5	Enabling/disabling of the panel switch	1B <sub>H</sub> 63 <sub>H</sub> 35 <sub>H</sub> n	65
ESC d	Printing, and line feeding of n lines	1B <sub>H</sub> 64 <sub>H</sub> n	66
ESC i	Full cutting	1B <sub>H</sub> 69 <sub>H</sub>	67
ESC p	Specified pulse generation (Drawer kick out)	1B <sub>H</sub> 70 <sub>H</sub> m n1 n2	68

Command	Function	Code	Reference page
ESC t	Selection of the character code table	1B <sub>H</sub> 74 <sub>H</sub> n	69
ESC v	Sending of the printer status	1B <sub>H</sub> 75 <sub>H</sub> n	70
ESC u	Sending of the peripheral equipment status	1P <sub>H</sub> 76 <sub>H</sub>	71
ESC {	Specifying/releasing of inverted printing	1B <sub>H</sub> 7B <sub>H</sub> n	72
ESC \$	Specifying of absolute positions	1B <sub>H</sub> 24 <sub>H</sub> n1 n2	73
ESC ¥	Specifying of relative positions	1B <sub>H</sub> 5C <sub>H</sub> n1 n2	75
GS FF	Printing, and label ejection (including cutting)	1D <sub>H</sub> 0C <sub>H</sub>	76
GS k	Bar code printing	1D <sub>H</sub> 6B <sub>H</sub> n ['d']k 00 <sub>H</sub>	77
GS w	Selection of bar code horizontal size	1D <sub>H</sub> 77 <sub>H</sub> n	82
GS h	Selection of bar code height	1D <sub>H</sub> 68 <sub>H</sub> n	83
GS H	Selection of visual code printing position	1D <sub>H</sub> 48 <sub>H</sub> n	83
GS f	Selection of visual code font	1D <sub>H</sub> 66 <sub>H</sub> n	84
GS c	Printing of counter	1D <sub>H</sub> 63 <sub>H</sub>	86
GS C0	Setting of the numbering printing mode	1D <sub>H</sub> 43 <sub>H</sub> 30 <sub>H</sub> m n	87
GS C1	Setting of the numbering counting mode (A)	1D <sub>H</sub> 43 <sub>H</sub> 31 <sub>H</sub> n1 n2 n3 n4 n5 n6	89
GS C2	Setting of the numbering counter	1D <sub>H</sub> 43 <sub>H</sub> 32 <sub>H</sub> n1 n2	92
GS C;	Setting of the numbering counting mode (B)	1D <sub>H</sub> 43 <sub>H</sub> 3B <sub>H</sub> "N 1" 3B <sub>H</sub> "N2" 3B <sub>H</sub> "N3" 3B <sub>H</sub> "N4" 3B <sub>H</sub> "N5" 3B <sub>H</sub>	95
GS *	Definition of the downloading/bit image	1D <sub>H</sub> 2A <sub>H</sub> n1 n2[d]n1 × n2 × 8	95
GS /	Printing of the downloading/bit image	1D <sub>H</sub> 2F <sub>H</sub> m	98
GS :	Starting/finishing of the macro defining	1D <sub>H</sub> 3A <sub>H</sub>	99
GS ^	Macro execution	1D <sub>H</sub> 5E <sub>H</sub> n1 n2 n3	100
GS <	Initialization of the printer mechanism	1D <sub>H</sub> 3C <sub>H</sub>	101
GS A	Correction of the label top position	1D <sub>H</sub> 41 <sub>H</sub> m n	102
GS R	Specifying/releasing of the black/white inverted characters	1D <sub>H</sub> 52 <sub>H</sub> n	105

Note : n, n1, n2, n3, m, a, s, p, and d in the table represent the parameters of each command.

Note : [ ] k in the table represents a repetition carried out k times.

Note : ' ' in the table represents an ASCII character.

Note : " " in the table represents a string of ASCII characters.



## 8.2 Details of commands

### 8.2.1 How to read each section

---

**xxxx**

---

[Name]	This is the command name
[Code]	In the line up of codes making up the command, < >H indicates hexadecimal notation, < >B indicates binary notation, and < > indicates decimal notation. [ ] k represents a repetition carried out k times.
[Function]	This section indicates the function of the command.
[Item requiring caution]	When necessary, items that require caution are written in this section.
[Initial values]	For commands that are accompanied by arguments, the initial values are written in this section.
[Reference]	Other commands related to the use of the command are written in this section.
[Program example]	Indicates a coding example using BASIC language.
[Printing result]	Indicates the printing result obtained by executing the program written above. However, the scale reduction of the printing result given in this section will differ from that of the actual printing result.

### 8.2.2 Detailed explanations

## HT

[Name] Horizontal tab command

[Code] <09>H

[Function] Moves the printing position to the next horizontal tab position.  
 • This command will be disregarded if the next horizontal tab position has not been set.

[Item requiring caution]  
 • The horizontal tab positions should be set using ESC D.  
 • In the initial settings, the horizontal tab positions will be set every 8 characters in font 1.  
 (At the 9th, 17th, and 25th columns.)

[Reference] ESC D

[Program example]

```
LPRINT "0123456789012345678901" ;
LPRINT CHR$ (&HA) ;
LPRINT CHR$ (&H9) + "AAA" ;
LPRINT CHR$ (&H9) + "BBB" ;
LPRINT CHR$ (&HA) ;
LPRINT CHR$ (&H1B) + "D" ;
LPRINT CHR$(3) + C}R$(7) + CHR$(14) + CHR$(0) ;
LPRINT CHR$(&H9) + "AAA" ;
LPRINT CHR$ (&H9) + "BBB" ;
LPRINT CHR$ (&H9) + "CCC" + CHR$(&HA) ;
```

[Printing result]

```
0123456789012345678901
      AAA      BBB ← Initial setting
                    of horizontal tabs
AAA BBB      CCC ← Situation where horizontal
                    tabs have been set to the
                    4th, 8th, and 15th columns.
```

---

**LF**

---

[Name]	Printing, and paper line feeding
[Code]	<0A>H
[Function]	Prints the data in the print buffer, and carries out line feeding based on the set line feeding amount. <ul style="list-style-type: none"> <li>• The next printing start position will be at the head of the line.</li> </ul>
[Reference]	ESC 2, ESC 3

[Program example]	[Printing result]
LPRINT "AAA" + CHR\$ (&HA) ;	AAA ← Printing and line feed
LPRINT "BBB" + CHR\$(&HA) ;	BBB ← Printing and line feed
LPRINT CHR\$ (&HA) ;	← Line feed only
LPRINT "CCC" + CHR\$ (&HA) ;	CCC ← Printing and line feed

---

**FF**

---

[Name]	Printing, and moving to the top of the label
[Code]	<0C>H
[Function]	Prints the data in the print buffer, and moves to the top of the next label.
[Items requiring caution]	<ul style="list-style-type: none"> <li>• This command will only be effective when label printings has been selected.</li> <li>• After sending a one-label portion of printing data, be sure to send an &lt;FF&gt; or &lt;GS FF&gt; command.</li> </ul>

- After the label paper has been deliberately moved by the user, it will not be possible to correctly move to the top of the label using this command. Accordingly, carry out the moving to the top of the label using the LF switch or by executing the <GS < > command.

[Reference]                    GS FF

[Program example]

```
LPRINT "AAA" + CHR$ (&HA) ;
LPRINT "BBB" + CHR$(&HA) ;
LPRINT CHR$(&H0C) ;
LPRINT "AAA" + CHR$ (&HA) ;
```

[Printing result]

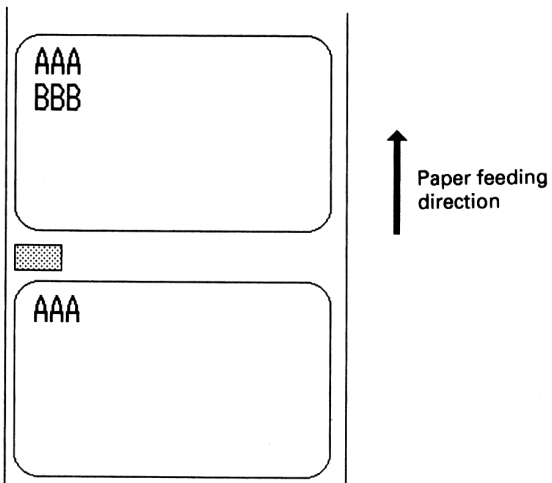

---

**CR**

---

[Name]                      Printing command

[Code]                      <0D>H

[Function]                      ① When DSW1-7 is OFF, this command will be disregarded.  
    ② When DSW1-7 is ON, the data in the print buffer will be printed, and line feeding will be carried out based on the set line feeding amount.

- The next printing start position will be at the head of the line.

[Items requiring caution]

- This command will only be effective for parallel interface printers.

[Reference]                      LF

[Program example]

```
LPRINT "AAA" + CHR$ (&HD) ;
LPRINT "BBB" + CHR$ (&HD) ;
LPRINT CHR$ (&HD) ;
LPRINT "CCC" + CHR$ (&HD) ;
```

[Printing result]

```
AAA ← Printing and line feed
BBB ← Printing and line feed
   ← Line feed only
CCC ← Printing and line feed
```

## ESC SP n

---

[Name]                    Setting of the amount of space to the right of the character

[Code]                    <1B>H <20>H <n>

[Defined range]         $0 \leq n \leq 32$

[Function]              Sets the amount of space to the right of the character in dot units (1/203 inch units).

[Items requiring caution]

In double wide mode, the amount of space to the right of the character will become two times the set amount.

[initial value]         n = 0

[Program example]

```
LPRINT CHR$( &H1B) + " " + CHR$( 0) ;
LPRINT "AAAAA" + CHR$( &HA) ;
LPRINT CHR$(&H1B) + " " + CHR$(1) ;
LPRINT "AAAAA" + CHR$( &HA) ;
LPRINT CHR$(&H1B) + " " + CHR$(12);
LPRINT "AAAAA" + CHR$( &HA) ;
```

[Printing result]

```
AAAAA ← 0 dot spacing
AAAAA ← 1 dot spacing
A A A A A ← 12 dot spacing
```

**ESC ! n**

[Name] Block setting of the printing mode

[Code] <1B>H <21>H <n>

[Defined range]  $0 \leq n \leq 255$

[Function] Specifies the printing mode.

Bit	Function	Value	
		0	1
0	Character font	Font 1	Font 2
1	Not defined		
2	Not defined		
3	Highlighting	Release	Specify
4	Double height enlargement	Release	Specify
5	Double wide enlargement	Release	Specify
6	Not defined		
7	Underlining	Release	Specify

## [Items requiring caution]

By specifying both the double height enlargement and the double wide enlargement, the double wide and double height enlarged character will be formed. Although underlining will be applied to the full width of the printing characters, underlining will not be applied to parts that have been skipped using the HT command. Further, underlining will also not be applied to characters that have been rotated 90° rightward.

The width of the underlining will be the width that has been specified using <ESC ->. (The default will be a 1 dot width.) In a situation where double height enlarged characters and ordinary characters are mixed together on one line, a layout will be adopted in which the underlining will coincide.

[Initial value]            n = 0

[Reference]                ESC E, ESC –

[Program example]

```
LPRINT CHR$(&H1B) + "!" + CHR$ (&H00) + "H " ;
LPRINT CHR$ (&H1B) + "!" + CHR$(&H01) + "H " ;
LPRINT CHR$(&H1B) + "!" + CHR$ (&H08) + "H " ;
LPRINT CHR$(&H1B) + "!" + CHR$(&H10) + "H " ;
LPRINT CHR$(&H1B) + "!" + CHR$ (&H20) + "H " ;
LPRINT CHR$(&H1B) + "!" + CHR$(&H80) + "H " ;
LPRINT CHR$(&H1B) + "!" + CHR$ (&HB9) + "H " ;
LPRINT CHR$ (&HA) ;
```

[Printing result]

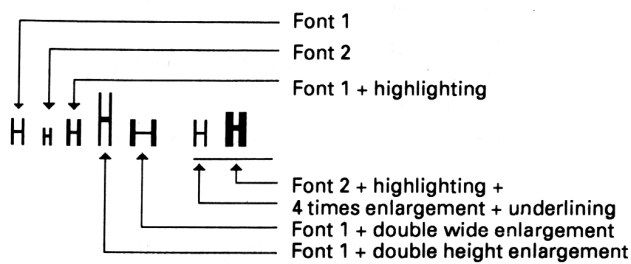

## ESC % n

[Name]                    Specifying/releasing of the downloading character set

[Code]                    <1B>H <25>H <n>

[Defined range]        0 ≤ n ≤ 255



[Function] Specifies or releases the downloading character set.

- Only the lowest bit of n will be valid.

When n = <\*\*\*\*\*1>B, the downloading character set is specified.

When n = <\*\*\*\*\*0>B, the downloading character set is released.

(Specifies the internal character set)

[Items requiring caution] It will not be possible to define downloading characters and downloading bit images at the same time.

[Initial value] n = 0

[Reference] ESC &

[Program example]

GOSUB SETCHR	DATA 6
LPRINT CHR\$(&H1B) + "%" + CHR\$(0) ;	DATA &HFF, &H80, &H00
LPRINT "@A" + CHR\$(&HA) ;	DATA &H80, &H80, &H00
LPRINT CHR\$(&H1B) + "%" + CHR\$(1) ;	DATA &H80, &H80, &H00
LPRINT "@A" + CHR\$(&HA) ;	DATA &H80, &H80, &H00
END	DATA &HFF, &HFF, &HFF
SETCHR :	DATA &HFF, &HFF, &HFF
LPRINT CHR\$(&H1B) + "&" ;	DATA 12
LPRINT CHR\$(3) + "@" + "A" ;	DATA &HFF, &HFF, &HFF
FOR J=1 TO 2	DATA &H80, &H07, &HF9
READ REP	DATA &H80, &HFF, &HF9
LPRINT CHR\$(REP) ;	DATA &H87, &HFE, &H01
FOR I=1 TO REP*3	DATA &H9F, &H06, &H01
READ D	DATA &HF8, &H06, &H01
LPRINTCHR\$(D) ;	DATA &HF8, &H06, &H01
NEXT I	DATA &H9F, &H06, &H01
NEXT J	DATA &H87, &HFE, &H01
RETURN	DATA &H80, &HFF, &HF9
	DATA &H80, &H07, &HF9
	DATA &HFF, &HFF, &HFF

[Printing result]

@A ← Internal character set

qA ← Downloading characters

## ESC & s n m [a [p] s x a] m - n + 1

[Name] Defining of downloading characters

[Code] <1B>H <26>H <s> <n> <m> [<a> <p1> <p2> .....<ps x a>] m-n+ 1

[Defined ranges]

$s = 3$

$32 \leq n \leq m \leq 126$

$0 \leq a \leq 12$  (Font 1)

$0 \leq a \leq 9$  (Font 2)

$0 \leq p1 \dots ps \times a \leq 255$

[Function]

Defines the alphanumeric and Kana character downloading character font.

s indicates the number of bytes in the vertical direction.

n indicated the starting character code, and m indicates the finishing character code.

When defining only 1 character, n should be made equal to m.

The character codes that may be defined are the total of 95 characters of ASCII code in the range between <20>H and <7E>H.

a indicates the number of dots defining the horizontal direction.

p is the data for defining, and indicates a pattern that is an a-pot portion from the left margin in the horizontal direction. The remaining pattern to the right side will be filled up with spaces, and the number of pieces of data for defining will be  $s \times a$ .

Once the downloading characters have been defined, the characters will remain valid until other characters are defined, or until the ESC @ or GS \* commands are executed, or until the power is switched off.

[Items requiring caution]

It will not be possible to define the downloading characters and the downloading bit images at the same time. When this command is executed, the defined downloading bit image contents will be cleared.

[Initial value]

The initial values will be the same as for the internal character set.

[Reference]

ESC %

[Example]

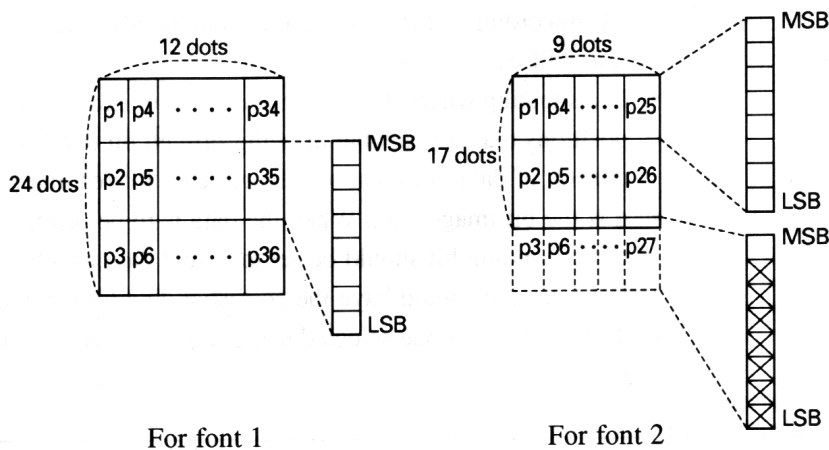

Each bit of the data is made up of '1' dots that will be printed and '0' dots that will not be printed.

[Program example]

[Printing result]

Refer to the program example and the printing result for ESC % on page 45-46.

## ESC \* m n1 n2 [d] k

[Name] Specifying of the bit image mode

[Code] <1B>H <2A>H <m> <n1> <n2> [<d>] k

[Defined ranges]

m = 0, 1, 32, 33

$0 \leq n1 \leq 255$

$0 \leq n2 \leq 3$

$0 \leq d \leq 255$

$k = n1 + 256 \times n2 \quad (m = 0, 1)$

$k = (n1 + 256 \times n2) \times 3 \quad (m = 32, 33)$

[Function]

This command specifies the bit image of mode m with regard to the number of dots specified by n1 and n2.

- The number of dots for printing will be divided by 256, and the quotient will become n2 with the remainder becoming n1, Accordingly, the number of dots in the horizontal direction will be  $n1 + 256 \times n2$ .
- In a situation where the bit image data input exceeds the dot positions that are capable of being printed on one line, the portion of data in excess will be rejected for reading.
- d is the bit image data. When the data is to be printed, the corresponding bit should be set to 1, and data which is not to be printed should have the corresponding bit set to 0.
- The bit image mode selected using m will be as shown below :

m	Mode	Vertical direction		Horizontal direction	
		Number of dots	Dot density	Dot density	Maximum number of dots
0	8-dots single density	8	67 DPI	101 DPI	224
1	8-dots double density	8	67 DPI	203 DPI	448
32	24-dot single density	24	203 DPI	101 DPI	224
33	24-dot double density	24	203 DPI	203 DPI	448

[Items requiring caution]

When the value of m is outside the conditions, data after n 1 will be processed as ordinary data. After completion of the bit image printing, the mode will return to normal data processing.

[Example]

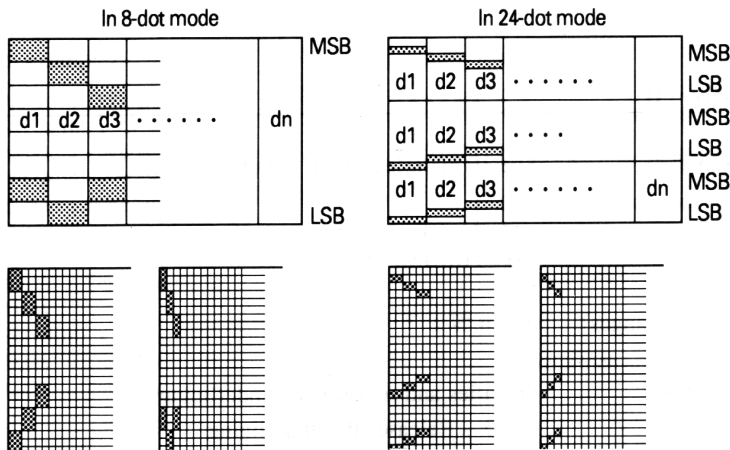

Printing result

[Program example]

```

LPRINT CHR$ (&H1B) + "*" ;
LPRINT CHR$(0) + CHR$(20) + CHR$(0) ;
GOSUB IMG1
LPRINT CHR$ (&HA) ;
LPRINT CHR$ (&H1B) + "*" ;
LPRINT CHR$ (1) + CHR$ (20) + CHR$ (0) ;
GOSUB IMG1
LPRINT CHR$(&HA) ;
LPRINT CHR$(&H1B) + "*" ;
LPRINT CHR$ (32) + CHR$ (20) + CHR$ (0) ;
GOSUB IMG2
LPRINT CHR$ (&HA) ;
LPRINT CHR$(&H1B) + "*";
LPRINT CHR$(33) + CHR$ (20) + CHR$(0) ;
GOSUB IMG2
LPRINT CHR$ (&HA) ;
END

```

```

IMG1:
LPRINT CHR$ (&HFF) ;
FOR I=1 TO 18
LPRINTCHR$ (&H85) ;
NEXT I
LPRINT CHR$ (&HFF) ;
RETURN
IMG2 :
LPRINT CHR$ (&HFF) ;
LPRINT CHR$ (&HFF) ;
LPRINT CHR$ (&HFF) ;
FOR I=1 TO 18
LPRINT CHR$ (&H80) ;
LPRINT CHR$ (&H00) ;
LPRINT CHR$ (&H05) ;
NEXT I
LPRINT CHR$ (&HFF) ;
LPRINT CHR$ (&HFF) ;
LPRINT CHR$ (&HFF) ;
RETURN

```

[Printing result]

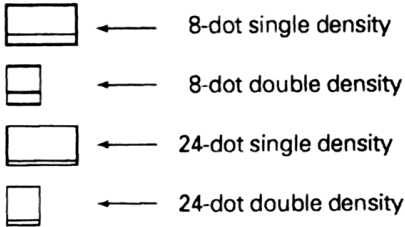

## ESC - n

[Name] Specifying/releasing of the underlining

[Code] <1B>H <2D>H <n>

[Defined ranges]  $0 \leq n \leq 2$

[Function] Specifies and releases the underlining.  
 n = 0 Releases the underlining  
 n = 1 Specifies 1 dot width underlining  
 n = 2 Specifies 2 dot width underlining

[Items requiring caution]

Although the underlining will be applied to the full width of the printing characters, underlining will not be applied to parts that have been skipped using the HT command. Underlining will not be applied to characters that have been rotated 90° rightward.

[Reference] ESC !, FS -

[Program example]

```
LPRINT CHR$ (&H1B) + " " + CHR$(0);
LPRINT "AAAAA" ;
LPRINT CHR$(&H1B) + "-" + CHR$(1) ;
LPRINT "AAAAA" + CHR$ (&HA) ;
```

[Printing result]

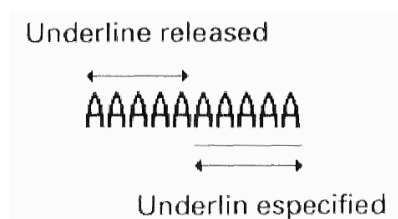

## ESC 2

[Name]                      Setting of the 1/6 inch line feeding amount

[Code]                      <1B>H <32>H

[Function]                 Sets the line feeding amount to 1/6 inch for each 1 line.

[Program example]

```
LPRINT "AAAAA" + CHR$ (&HA) ;
LPRINT CHR$(&H1B) + "3" + CHR$(0) ;
LPRINT "AAAAA" + CHR$ (&HA) ;
LPRINT CHR$ (&H1B) + "3" + CHR$(50) ;
LPRINT "AAAAA" + CHR$(&HA) ;
LPRINT CHR$ (&H1B) + "2" ;
LPRINT "AAAAA" + CHR$(&HA) ;
LPRINT "AAAAA" ;
LPRINT CHR$(&H1B) + "J" + CHR$(100) ;
LPRINT "AAAAA" + CHR$ (&HA) ;
LPRINT "AAAAA" + CHR$(&HA) ;
```

[Printing result]

---

**ESC 3 n**

---

[Name]                      Setting of the line feeding amount in minimum paper feeding pitch units

[Code]                      <1B>H <33>H <n>

[Defined range]             $0 \leq n \leq 255$

[Function]                 Sets the line feeding amount to  $n/203$  inch for each 1 line.

[Items requiring caution]

When label printing has been specified, if line feeding is carried out by specifying a paper feeding amount in excess of the label length, the line feeding will be carried out up to the position at the top of the following label. Because the printing will be accompanied by line feeding, even if printing is carried out when a smaller value than the line feeding amount of 1 line has been set, line feeding of more than the set amount may be carried out due to the printing operation.

[Initial value]              $n = 34$  (1/6 inch)

[Program example]        [Printing result]

Refer to the program example and the printing result for ESC 2 on page 51.



**ESC = n**

[Name] Data input control

[Code] <1B>H <3D>H <n>

[Defined range]  $0 \leq n \leq 255$

[Function]

Selects the effective equipment for data input from the host unit.

Each bit of n has the meaning shown in the table below. When the printer is in the de-selected condition, the printer will reject reading any of the received data until the printer has been set to the selected condition using this command.

Bit	Function	Value	
		0	1
0	Printer	Invalid	Valid
1	Not defined		
2	Not defined		
3	Not defined		
4	Not defined		
5	Not defined		
6	Not defined		
7	Not defined		

[Items requiring caution]

It will be possible that the printer will change to the BUSY condition due to the printer operation even while the printer is in the de-selected condition.

[Initial value]  $n = 1$

[Program example]

```
LPRINT "AAAAA" ;
LPRINT CHR$ (&H1B) + "=" + CHR$ (0) ;
LPRINT "aaaaa" + CHR$ (&HA) ;
LPRINT CHR$(&H1B) + "=" + CHR$(1) ;
LPRINT "AAAAA" + CHR$ (&HA) ;
```

[Printing result]

```
AAAAAAAAAAAA
  ↑
aaaaa is not printed
```

**Esc @**

[Name]                      Printer initialization

[Code]                      <1B>H <40>H

[Function]                  Clears the data in the print buffer, and sets various settings to the initial conditions.  
(Default conditions)

[Items requiring caution]

The setting contents of the dip switches will not be read in again during this operation.  
The data in the receiving buffer will not be cleared during this operation.

[Program example]

```
LPRINT CHR$ (&H1B) + " !" + CHR$ (&H30) ;
LPRINT CHR$(&H1B) + "V" + CHR$(1);
LPRINT "AAA" + CHR$ (&HA) ;
LPRINT CHR$ (&H1B) + "@" ;
LPRINT "AAA" + CHR$ (&HA) ;
```

[Printing result]

```
!V@
AAA ← Using the reset
       command, each
       setting will be set to
       the initial conditions.
```

**ESC D [n] k NUL**

[Name]                      Setting of the horizontal tab positions

[Code]                      <1B>H <44>H [<n>] k <00>H

[Defined ranges]             $1 \leq n \leq 255$   
 $0 \leq k \leq 32$

[Function]

Sets the horizontal tab positions. n indicates the number of columns from the head of the line to the position that the horizontal tab is to be set. Because 'n = setting columns position - 1', for an example in which the horizontal tab is to be set at the 9th column, n should be set to 8.

k indicates the number of horizontal tab positions to be set. Although the tab positions will be set at positions that are (n × the character width) from the head of the line, the character width in this case will include the amount of space to the right of the character.

Further, when the two-times horizontal character enlargement has been specified, the tab position spacing will become twice wider than normal.

Tab positions may be set to a maximum of 32 locations, and tab position settings in excess of this number will be disregarded.

The <n> k data that indicates the setting positions should be input in order from the smallest value first, and should finish with <00>H.

The ESC <D NUL> command clears all the set tab positions. HT commands executed after all the tabs have been cleared will be disregarded.

## [Items requiring caution]

If the <n> k data is the same value or is smaller than the immediately previous <n> k - 1 data, the tab setting will be regarded as having been completed. In this situation, subsequent data will be processed as normal data.

If the <n> k data exceeds the printing range of one line, the data will be set as the 'Set figure position = Maximum printing figure +1'.

After setting the horizontal tab positions, the horizontal tab positions will not change even when the character width is changed.

## [Initial value]

Tabs will be set at every 8 characters in font 1. (At the 9th, 17th, 25th columns)

## [Reference]

HT

## [Program example]

## [Printing result]

Refer to the program example and printing result for HT on page 38.

**ESC E n**

## [Name]

Specifying/releasing of the highlighting

## [Code]

<1B>H <45>H <n>

## [Function]

Specifies and releases the highlighting.

- When n = <\*\*\*\*\*0>B. the highlighting will be released.
- When n = <\*\*\*\*\*1>B. the highlighting will be specified.

This command will be effective for all types of character. The highlighting will add one dot horizontally to each dot of the character.

## [Reference]

ESC !

[Example]

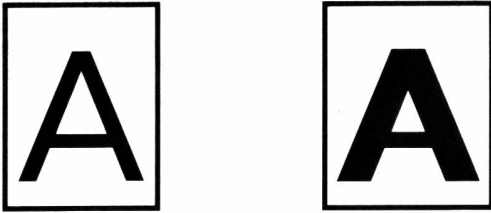

[Program example]

```
LPRINT CHR$ (&H1B) + "E" + CHR$ (0) ;
LPRINT "AAABBB" + CHR$ (&HA) ;
LPRIT CHR$(&H1B) + "E" + CHR$(1) ;
LPRINT "AAABBB" + CHR$(&HA) ;
```

[Printing result]

```
AAABBB ← Highlighting released
AAABBB ←
```

## ESC G n

[Name]                      Specifying/releasing of the double printing

[Code]                      <1B>H <47>H <n>

[Function]                      Specifies and releases the double printing.

- When n = <\*\*\*\*\*0>B, the double printing will be released.
- When n = <\*\*\*\*\*1>B, the double printing will be specified.

This command will be effective for all character types.

[Items requiring caution]                      In this printer, the double printing and highlighting will be absolutely identical.

[Reference]                      ESC E

[Program example]

```
LPRINT CHR$ (&H1B) + "G" + CHR$ (0) ;
LPRINT "AAABBB" + CHR$ (&HA) ;
LPRINT CHR$ (&H1B) + "G" + CHR$ (1) ;
LPRINT "AAABBB" + CHR$(&HA) ;
```

[Printing result]

```
AAABBB ← Double printing
          released
AAABBB ← Double printing
          specified
```

## ESC J n

[Name] Printing, and paper feeding in minimum pitch units

[Code] <1B>H <4A>H <n>

[Defined range]  $0 \leq n \leq 255$

[Function]

Prints the data in the printer buffer, and then carries out paper feeding of  $n/203$  inch. The set paper feeding value will not remain after this function has been carried out.

The next printing start position will be the head of the line. When label printing has been selected, if the specified paper feeding amount exceeds the label length. the line feeding will be carried out up to a position at the top of the following label. Because the printing will be accompanied by line feeding, even if printing is carried out when a smaller value than the line feeding amount of 1 line has been set, line feeding of more than the set amount may be carried out due to the printing operation.

[Initial value] Not defined.

[Program example] [Printing result]

Refer to the program example and the printing result for ESC 2 on page 51.

**ESC R n**

[Name] Selection of international characters

[Code] <1B>H <52>H <n>

[Defined range]  $0 \leq n \leq 10$

[Function] Selects the character sets of the countries shown in the table below according to the n value.

n	Character set
0	U.S.A
1	France
2	Germany
3	U.K.
4	Denmark I
5	Sweden
6	Italy
7	Spain
8	Japan
9	Norway
10	Denmark II

[Initial value]  $n = 0$

[Reference] See the character code tables (International character sets)

<p>[Program example]</p> <pre>FOR I=0 TO 10 LPRINT CHR\$ (&amp;H1B) + "R" + CHR\$ (1); LPRINT " #\${¥}^"; LPRINT CHR\$ (&amp;H60) + " {¥}^- "; LPRINT "n =" + STR\$ (1); LPRINT CFR\$(&amp;HA); NEXT I</pre>	<p>[Printing result]</p> <pre>##\$@[\]^`{\}~ n = 0 ##\$à°ç\$^`éçè" n = 1 ##\$ŠÄÖÜ^`äöüß n = 2 £\$@[\]^`{\}~ n = 3 ##\$ÉËÏÄÜéäöäü n = 4 ##\$ÉËÏÄÜéäöäü n = 5 ##\$@°\é^ùà\èì n = 6 ##\$@;ñ¿^`~Ñ}~ n = 7 ##\$@[¥]^`{¥}~ n = 8 ##\$ÉËÏÄÜéäöäü n = 9 ##\$ÉËÏÄÜéäöäü n = 10</pre>
--	---

## ESC V n

[Name]	Specifying or releasing of 90° right turned characters
[Code]	<1B>H <56>H <n>
[Defined range]	0 ≤ n ≤ 1
[Function]	<p>Specifies or releases the character 90° rightward rotation.</p> <p>n = 1 Specifies character 90° rightward rotation.</p> <p>n = 0 Releases character 90° rightward rotation.</p>
[Items requiring caution]	Underlining can not be applied to characters that have been rotated 90° rightward.
[Initial value]	n = 0



[Program example]

```
LPRINT CHR$ (&H1B) + "V" + CHR$ (0) ;
LPRINT "AAAAA" ;
LPRINT CHR$(&H1B) + "V" + CHR$(1) ;
LPRINT "AAAAA" + CHR$(&HA) ;
```

[Printing result]

90° rotation released

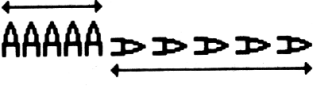

90° rotation specified

## ESC a n

[Name] Selection of printing position justification

[Code] <1B>H <61>H <n>

[Defined ranges]  $0 \leq n \leq 2$

[Function] Aligns all the printing data on one line to the specified position. The position aligning will be carried out according to the n value as shown in the table below.

n	Position
0	Left end aligning
1	Centering
2	Right end aligning

[Items requiring caution] This command will only be valid when it has been input at the head of the line.

[Initial value] n = 0

[Program example]

```
LPRINT CHR$(&H1B) + "a" + CHR$(0) ;
LPRINT "AAAAA" + CHR$ (&HA) ;
LPRINT CHR$(&H1B) + "a" + CHR$(1) ;
LPRINT "AAAAA" + CHR$ (&HA) ;
LPRINT CHR$(&H1B) + "a" + CHR$(2) ;
LPRINT "AAAAA" + CHR$(&HA) ;
```

[Printing result]

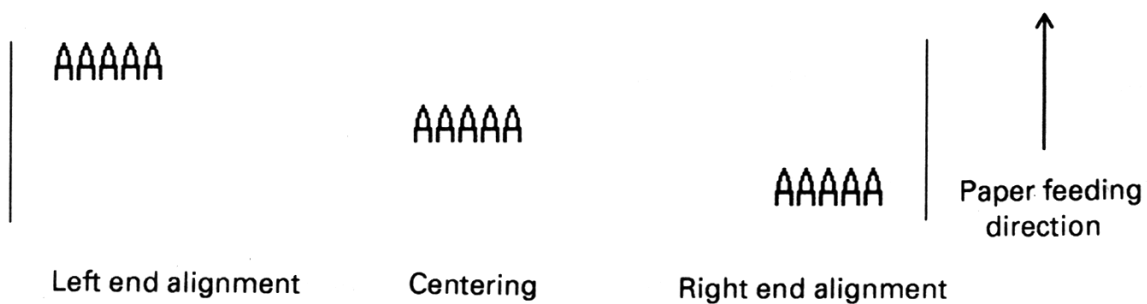

### ESC c 3 n

[Name] Selection of the effective paper end detector for output of the paper end signal

[Code] <1B>H <63>H <33>H <n>

[Defined range]  $0 \leq n \leq 255$

[Function]                      Selects which of the paper end detector conditions will be used for the paper end signal output.

Each bit of n will have the meanings shown in the table below.

Bit	Function	Value	
		0	1
0	Journal near-end	Disabled	Enabled
1	Not defined		
2	Not defined		
3	Not defined		
4	Not defined		
5	Not defined		
6	Not defined		
7	Not defined		

In this printer, only one type of paper near-end detector can be selected for the paper end detection, and only the lowest bit of n will be effective .

[Items requiring caution]

This command will only be effective for parallel interface printers .

[Initial value]                      n = 1

[Program example]

LPRINT CHR\$ (&H1B) + "c3" + CHR\$ (0) ;    ····

LPRINT CHR\$(&H1B) + "c3" + CHR\$ (1) ;    ····

Situation in which the no paper signal is output by the paper end detector.

Situation in which no paper signal is output by the paper near-end detector.

**ESC c 4 n**

[Name] Selection of the effective paper end detector for stopping the printing

[Code] <1B>H <63>H <34>H <n>

[Defined range]  $0 \leq n \leq 255$

[Function] Selects which of the paper end detector conditions will be used for the paper end signal output.

Each bit of n will have the meanings shown in the table below.

Bit	Function	Value	
		0	1
0	Journal near-end	Disabled	Enabled
1	Not defined		
2	Not defined		
3	Not defined		
4	Not defined		
5	Not defined		
6	Not defined		
7	Not defined		

In this printer, only one type of paper near-end detector can be selected for the paper end detection, and only the lowest bit of n will be effective.

[Items requiring caution]

When the printing stopping is set to enabled, the printing stopping position will be the position set by the DSW1-5 and DSW1-6 switches. After the printing has been stopped, the printer will change to the off-line condition.

[Initial value]  $n = 0$

[Program example]

LPRINT CHR\$ (&H1B) + "c4" + CHR\$ (0) ; ····

Situation in which the printing has been stopped by the paper end detector.

LPRINT CHR\$ (&H1B) + "c4" + CHR\$ (1) ; ····

Situation in which the printing has been stopped by the paper near-end detector.

## ESC c 5 n

[Name]                      Enabling/disabling of the panel switch

[Code]                      <1B>H <63>H <35>H <n>

[Defined range]             $0 \leq n \leq 255$

[Function]                   Changes the LF switch between enabled and disabled.  
 • Only the lowest bit of n will be effective.  
 When n = <\*\*\*\*\*0>B, the LF switch will be enabled.  
 When n = <\*\*\*\*\*1>B, the LF switch will be disabled.

[Items requiring caution]            When the panel switch has been disabled using this command, the LF switch will not be effective. Accordingly, it will not be possible to execute line feeding by operation of the LF switch.

[Initial value]              n = 0

[Program example]

LPRINT CHR\$(&H1B) + "c5" + CHR\$ (0) ; ····

Situation in which the LF switch operation is valid.

LPRINT CHR\$(&H1B) + "c5" + CHR\$ (1) ; ····

Situation in which the LF switch operation is invalid.

## ESC d n

[Name]                      Printing. and line feeding of n lines

[Code]                      <1B>H <64>H <n>

[Defined range]             $0 \leq n \leq 255$

[Function]

Prints the data in the print buffer, and carries out a n -line portion of line feeding.  
 The next printing start position will be at the head of the line. The setting amount will not remain after this operation has been carried out.  
 When label printing has been selected, if the specified paper feeding amount exceeds the label length, the line feeding will be carried out up to a position at the top of the following label. Because the printing will be accompanied by line feeding, even if printing is carried out when a smaller value than the line feeding amount of 1 line has been set, line feeding of more than the set amount may be carried out due to the printing operation.

[Initial value]              Not defined.

[Program example]

```
LPRINT "AAAAA" ;
LPRINT CHR$(&H1B) + "d" + CHR$(2) ;
LPRINT "AAAAA" + CHR$ (&HA) ;
```

[Printing result]

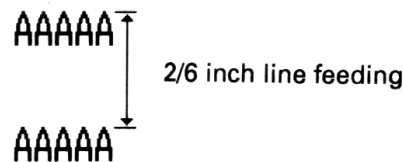

## ESC i

[Name] Full cutting

[Code] <1B>H <69>H

[Function] When the thermal paper has been selected, this command executes a full cut of the printing paper. When label paper has been selected, line feeding of the label will be carried out up to the cutting position (between the labels), and then the label will be cut and ejected by the autocutter.

After ejection of the label, paper feeding will be carried out in the reverse direction to move to the top of the next label.

[Items requiring caution]

This command will only be effective when input at the head of the line.

When thermal paper has been selected, make sure to feed the paper over 18mm before cutting the paper. Because characters right after printing are left inside of the cutter.

[Program example]

```
LPRINT "AAAAA" ;
LPRINT CHR$(&H1B) + "J" ;
LPRINT CHR$ (150) ;
LPRINT CHR$ (&H1B) + "i" ;
LPRINT "AAAAA" ;
LPRINT CHR$(&H1B) + "J" ;
LPRINT CHR$ (150) ;
LPRINT CHR$ (&H1B) + "i" ;
```

[Printing result]

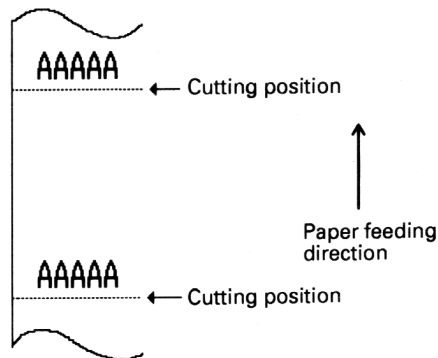

## ESC p m n1 n2

[Name] Specified pulse generation

[Code] <1B>H <70>H <m> <n1> <n2>

[Defined ranges] m= 0, 1  
 $0 \leq n1 \leq n2 \leq 255$

[Function] Outputs the signals specified by n1 and n2 to the connector pin m. The types of m pins are according to the table below.

m	Connector pin
0	Drawer kick No. 2 pin (Drawer kick-out terminal 1)
1	Drawer kick No. 5 pin (Drawer kick-out terminal 2)

The ON time will be  $n1 \times 2ms$ , and the OFF time will be  $n2 \times 2ms$ .

[Items requiring caution]

If m is outside the defined range, n1 and n2 will be rejected for reading and the signal will not output.

It is essential that the driving duty of the drawer should be within the following range.

$$(ON\ time / (ON\ time + OFF\ time)) \leq 0.2$$

(The OFF time should be at least 4 times more than the ON time.)

[Initial values] None of the values of m, n1 and n2 are defined.

[Program example]

```
LPRINT CHR$(&H1B) + "p"
```

```
LPRINT CHR$ (0) ; ..... Selection of the No. 2 pin
```

```
LPRINT CHR$ (5) ; ..... The ON time is set to 10ms
```

```
LPRINT CHR$ (50) ; ..... The OFF time is set to 100ms
```



## ESC t n

[Name] Selection of the character code table

[Code] <1B>H <74>H <n>

[Defined range]  $0 \leq n \leq 1$

[Function] Selects page n of the character code tables. The character code table will be selected according to the value of n.

n	Character code page
0	Page 0 (IBM character #2)

[Initial value] n = 0

[Reference] See the character code tables.

[Program example]

[Printing result]

```
LPRINT CHR$(&H1B) + "t" + CHR$(0);
LPRINT "n = 0";
FOR C=&HB1 TO &HB5
  LPRINT CHR$(C);
NEXT C
LPRINT CHR$ (&HA);
LPRINT CHR$(&H1B) + "t" + CHR$(1);
LPRINT "n = 1 ";
FOR C=&HB1 TO &HB5
  LPRINT CHR$(C);
NEXT C
LPRINT CHR$ (&HA);
```

```

t
n = 0
a b c d e
a b c d e
t
n = 1
a b c d e
a b c d e
```

**Page 0**

## ESC v

[Name]                      Sending of the printer status (only Serial interface)

[Code]                      <1B>H <76>H

[Function]                 Sends the status of the printer at the current point of time.

[Items requiring caution]

The status that is sent will be 1 byte of data, and the contents will be as shown in the table below. When the control is set to DTR/DSR, 1 byte only should be sent after confirming that the host is in the receiving possible condition (the DSR signal is at 'space'). Further, when the control is set to XON/XOFF, one byte only should be sent without confirming the DSR signal condition.

When the control is set to DTR/DSR and the host is in the receiving not possible condition (the DSR signal is at 'mark'), wait until the DSR signal is in the receiving possible condition. In the paper end (paper near-end) condition, there may be instances in which receiving of this command may not be possible due to the BUSY condition.

This command will only be effective in serial interface printers .

Bit	Function	0	1
0	Paper near-end	Paper present	No paper
1	Not defined		
2	Paper end	Paper present	No paper
3	Not defined		
4	Not used	Fixed at 0	
5	Not defined		
6	Not defined		
7	Not defined		

[Program example]

```
OPEN "COM1 :N81NN" AS #1
PRINT #1,CHR$ (&H1B) + "v" ;
A$ = INPUT$(1,#1)
CLOSE #1
```

**ESC u n**

[Name]                      Sending of the peripheral equipment status (Only serial interface)

[Code]                      <1B>H <75>H <n>

[Defined range]            n = 0

[Function]                 Send the status of connector pin 3 at the current point of time. The types of n are according to the table below.

n	Connector pin
0	Drawer kick connector pin No. 3 (Drawer open/close detection terminal).

[Item requiring caution]

The status that is sent will be 1 byte of data, and the contents will be as shown in the table below. When there is no equipment connected to the connector, bit 0 of n will always be '1'.

When the control is set to DTR/DSR, 1 byte only should be sent after confirming that the host is in the receiving possible condition (the DSR signal is at 'space'). Further, when the control is set to XON/XOFF, one byte only should be sent without confirming the DSR signal condition.

When the control is set to DTR/DSR and the host is in the receiving not possible condition (the DSR signal is at 'mark'), wait until the DSR signal is in the receiving possible condition.

This command will only be effective in serial interface printers .

Bit	Function	Value	
		0	1
0	Level of pin No. 3	'L'	'H'
1	Not defined		
2	Not defined		
3	Not defined		
4	Not used	Fixed at 0	
5	Not defined		
6	Not defined		
7	Not defined		

[Initial value] Not defined

[Program example]

```
OPEN "COM1:N81NN" AS #1
PRINT #1,CHR$(&H1B) + "u" + CHR$(0) ;
A$ = INPUT$(1,#1)
CLOSE #1
```

## ESC { n

[Name] Specifying/releasing of inverted printing

[Code] <1B>H <7B>H <n>

[Defined range]  $0 \leq n \leq 255$

[Function] Specifies and releases the inverted printing.

- Only the lowest bit of n will be effective.

n = <\*\*\*\*\*1>B Specifies inverted printing  
n = <\*\*\*\*\*0>B Releases inverted printing

[Items requiring caution]

Inverted printing is the printing of the line rotated through 180°. This command will only be effective when it is input at the head of the line.

[Initial value]                    n = 0

[Program example]

```
LPRINT CHR$ (&H1B) + "I" + CHR$ (0) ;
LPRINT "AAAAA" + CHR$ (&HA) ;
LPRINT "BBBBB" + CHR$ (&HA) ;
LPRINT CHR$(&H1B) + "I" + CHR$(1) ;
LPRINT "AAAAA" + CHR$(&HA) ;
LPRINT "BBBBB" + CHR$ (&HA) ;
```

[Printing result]



## ESC \$ n1 n2

[Name]                                Specifying of absolute positions

[Code]                                <1B>H <24>H <n1><n2>

[Defined ranges]                    0 ≤ n1 ≤ 255  
     0 ≤ n2 ≤ 1

[Function]                            Specifies the printing starting position as a number of dots (1/203 inch units) from the head of the line.  
 The number of dots is divided by 256, with the quotient becoming n2 and the remainder becoming n1. Accordingly, the printing starting position will be n1 + n2 × 256 dots from the head of the line.

The number of the dots can be specified is as follows.

447 dot (Thermal paper)

423 dot (Thermal label paper)

[Items requiring caution]

Specifications that exceed the end of the line will be disregarded.

When underlining has been specified, the underlining will not be applied to the moved portion.

[Initial value] Not defined

[Reference] ESC ¥

[Program example]

```
LPRINT CHR$ (&H1B) + "$" ;
LPRINT CHR$ (0) + CHR$ (0) + "A" ;
LPRINT CHR$ (&H1B) + "$" ;
LPRINT CHR$ (50) + CHR$ (0) + "B" ;
LPRINT CHR$ (&H1B) + "$" ;
LPRINT CHR$(0) + CHR$(1) + "C";
LPRINT CHR$ (&HA) ;
LPRINT CHR$(&H1B) + "$";
LPRINT CHR$ (100) + CHR$(0) + "A" ;
LPRINT CHR$ (&H1B) + "¥" ;
LPRINT CHR$ (&HC2) + CHR$ (&HFF) + "B" ;
LPRINT CHR$ (&HA) ;
```

[Printing result]

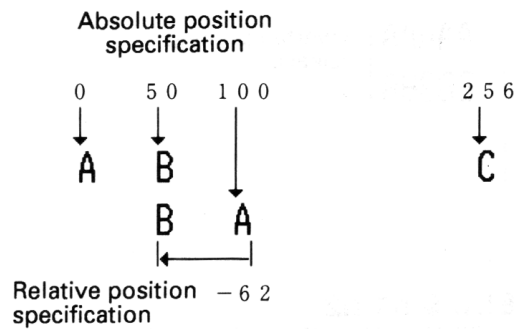

**ESC ¥ n1 n2**

[Name]	Specifying of relative positions
[Code]	<1B>H <5C>H <n1><n2>
[Defined range]	$0 \leq n1 \leq 255$ $0 \leq n2 \leq 255$
[Function]	<p>Specifies the printing starting position as a number of dots (1/203 inch units) from the current position. The right direction should be plus and the left direction should be minus. When specifying N dots in the minus direction, the specifying should be carried out using the complement of N.</p> <p style="text-align: center;">-N dots = 65536 - N</p> <p>The number of dots should be divided by 256, with the quotient becoming n2 and the remainder becoming n1.</p>
[Items requiring caution]	<p>Specifications that exceed the beginning or the end of the line will be disregarded. When underlining has specified, the underlining will not be applied to the moved portion.</p>
[Initial value]	Not defined
[Reference]	ESC \$
[Program example]	[Printing result]
Refer to the program example and the printing result for ESC \$ on page 74.	

**GS FF**

[Name] Printing, and label ejection

[Code] <1D>H <0C>H

[Function] Prints the data in the print buffer, and carries out the cutting and ejecting of the label.

- Line feeding of the label will be carried out up to the cutting position (between the labels), then the label will be cut and ejected using the auto-cutter.
- After ejection of the label, paper feeding will be carried out in the reverse direction to move to the top of the next label.
- After setting the top of the next label, the alarm LED will flash, and the printer will wait until the LF switch is pressed.

[Items requiring caution]

- After confirming that the alarm LED is flashing, press the LF switch one time.
- This command will only be effective when label printing has been selected.
- After sending a one-label portion of printing data, it is essential to send the <FF> command or <GS FF> command.

[Reference] FF

[Program example]

```
LPRINT "LABEL 1" ;
LPRINT CHR$ (&H1D) + CHR$(&HC) ;
```

[Printing result]

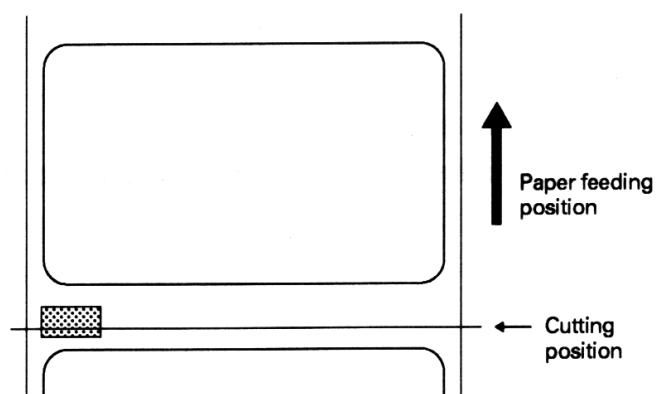



**GS k n [d]k NUL**

[Name]	Bar code printing
[Code]	<1D>H <6B>H <n> [<d>] k <00>H
[Defined range]	$0 \leq n \leq 7$
[Function]	<p>Selects the bar code type, and carries out bar code printing. The next printing starting position will be taken as the head of the line.</p> <p>The bar code systems shown in the table below will be selected according to the n value. d indicates the characters for printing, and k shows the number of characters for printing.</p>

n	Bar code type
0	UPC-A
1	UPC-E
2	JAN-13 (EAN)
3	JAN-8 (EAN)
4	CODE 39
5	ITF
6	CODABAR (NW-7)
7	CODE 128

**[Items requiring caution]**

When there is data present in the print buffer, this command will be disregarded. Regardless of the currently set line feeding amount, only the line feeding required for the bar code printing will be carried out.

In each of the bar code type, when the character code d contains characters that cannot be printed, the bar code up to this point will be printed and the subsequent data will be processed as ordinary data.

When a bar code type has been selected in which the number of printing characters is fixed, the number of characters  $k$  must correspond to this fixed number of printing characters.

When the horizontal direction exceeds a one line length. the part in excess will not be printed.

[Initial values]            Not defined

[Explanation of each bar code]

<Refer to print sample on page 6.>

UPC-A                      This is a fixed-length bar code that is composed of 12 figures of numerals only. 11 of the figures of the number should be input using software by the host unit or application, and the 12th figure is a check digit that will be automatically calculated inside the printer, If the 12th figure of the number is also sent from the host unit, the complete bar code will be printed as it is.

UPC-E                      This is a fixed-length bar code that is composed of 8 figures of numerals only. The first number system character is fixed as '0'. The 12-figure number should be input using software by the host unit or application, and this number will be compressed to a 8 -figure number with a check digit before being printed. Although the 12th figure check digit will be automatically calculated inside the printer if the 12th figure of the number is also sent the host unit, to complete bar code as it is will be compressed to the 8-figure number and printed.

JAN- 13 (EAN)            This is a fixed-length bar code that is compressed of 13 figures of numerical values only. 12 of the figures of the number should be input using software by the host unit or application, and the 13th figure is a check digit that will be automatically calculated inside the printer. If the 13th figure of the number is also sent from the host unit, the complete bar code will be printed as it is.

- JAN-8 (EAN) This is a fixed-length bar code that is composed of 8 figures of numerical values only. 7 of the figures of the number should be input using software by the host unit or application, and the 8th figure is a check digit that will be automatically calculated inside the printer. If the 8th figure of the number is also sent from the host unit, the complete bar code will be printed as it is.
- CODE 39 This is a variable-length bar code that is composed of alphabet capital letters and numerals. The start and stop code ' \* ' marks are attached automatically by the printer. Characters that can be used are spaces, '\$%\*+-. /0123456789', and the alphabet capital letters.
- ITF This is an even-numbered variable-length bar code that is composed of numerals only. If an odd number figure code is transmitted, the last figure will be discarded in order to make an even numbered figure before printing.
- CODABAR This is a variable-length bar code that is composed of alphanumeric characters. Characters which may be used are '0123456789abcd\$+-. /: ' . Start and stop codes will be required, which can be any one of 'abcd' .
- CODE 128
- This is a variable-length bar code that is composed of any of the 128 characters of ASCII code. Code sub-sets A, B, and C are supported by this printer, and the code sub-set at the start of printing should be selected by setting 1 character of any of 'ABC' at the head of the transmission code. If no 'ABC' character has been set at the head of the code, the code sub-set B will be selected.
  - Code sub-set A is a bar code made up of the standard capital letters of the alphabet, numerals, symbols, and special codes.
  - Code sub-set B is a bar code made up of the standard capital and small letters of the alphabet, numerals, control codes, and special characters.

- Code sub-set C is a bar code made up of special characters together with the 100 numbers between 00 and 99.
- After inputting the number of figures, a check digit will be automatically calculated inside the printer and added to the figures, and then printing will be carried out.
- Processing of special characters

Characters having an ASCII code number of 96 or greater will be recognized as special characters. The switching characters required to input these characters are given below.

ASCII code	Switching character	Sub-set code A	Sub-set code B	Sub-set code C
96	80h	FNC3	FNC 3	N/A
97	81h	FNC 2	FNC 2	N/A
98	82h	SHIFT	SHIFT	N/A
99	83h	CODE C	CODE C	N/A
100	84h	CODE B	FNC 4	CODE B
101	85h	FNC 4	CODE A	CODE A
102	86h	FNC 1	FNC 1	FNC 1

The following shows an example of the selection of the code sub-set using this special character method.

<Code sub-set selection>

Initial selection: 1 character input of any of 'A, B or C'.

Switching during operation: 1 character input of any of the 82h~85h characters.

e.g. In a situation where first the bar code 'TEST' is to be printed using code sub-set B, and then the bar code '123' is to be printed using code sub -set A.

Input codes:      B TEST <85h> 123

Bar code data:    <CODE B>TEST<CODE A>123

[Program example]

```
LPRINT CHR$(&H1D) + "H" + CHR$ (2) ;  
LPRINT CHR$ (&H1D) + "k" ;  
LPRINT CHR$(4) ;  
LPRINT "123" + CHR$ (0) ;
```

[Printing result]

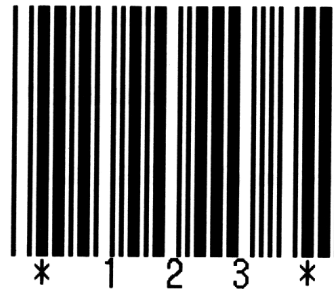

In a situation where the data " 1 2 3 " has been printed as code 39.

**GS w n**

[Name] Selection of bar code horizontal size (enlargement rate)

[Code] <1D>H <77>H <n>

[Defined range]  $2 \leq n \leq 4$

[Function] Selects the bar code horizontal size.  
n indicates the number of dots of the fine element width.

[Initial value]  $n = 3$

[Program example]

```
LPRINT CHR$(&H1D) + "h" + CHR$ (30) ;
LPRINT CHR$(&H1D) + "w" + CHR$(2) ;
GOSUB BC
LPRINT CHR$(&H1D) + "h" + CHR$ (50) ;
LPRINT CHR$(&H1D) + "w" + CHR$ (3) ;
GOSUB BC
LPRINT CHR$(&H1D) + "h" + CHR$(80) ;
LPRINT CHR$(&H1D) + "w" + CHR$(4) ;
GOSUB BC
END
BC :
LPRINT CHR$(&H1D) + "k" : LPRINT CHR$ (4) ;
LPRINT "12" + CHR$(0) ;
RETURN
```

[Printing result]

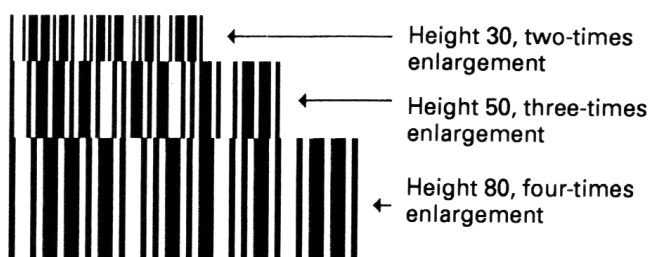

**GS h n**

[Name]	Selection of bar code height
[Code]	<1D>H <68>H <n>
[Defined range]	$1 \leq n \leq 255$
[Function]	Selects the bar code height. n indicates the number of dots in the vertical direction.
[Initial value]	n = 170

## [Program example]

Refer to the program example and the printing result for GS w on page 82.

**GS H n**

[Name]	Selection of visual code printing position
[Code]	<1D>H <48>H <n>
[Defined range]	$0 \leq n \leq 3$
[Function]	Selects the printing position of the visual code when printing the bar code. The printing positions that may be selected according to the n value are shown in the table below.

n	Printing position
0	Not printed
1	Above the bar code
2	Below the bar code
3	Both above and below the bar code

The visual code is the showing of the bar code in characters so that the bar code can be read visually.

[Items requiring caution] The visual code will be printed using the font selected using GS f.

[Initial value] n = 0

[Reference] GS f

[Program example]

```
LPRINT CHR$ (&H1B) + "3" + CHR$(5) ;
LPRINT CHR$ (&H1D) + "h" + CHR$ (50) ;
LPRINT CHR$ (&H1D) + "H" + CHR$ (0) ;
GOSUB BC
LPRINT CHR$ (&H1D) + "H" + CHR$ (1) ;
GOSUB BC
LPRINT CHR$ (&H1D) + "H" + CHR$ (2) ;
GOSUB BC
LPRINT CHR$(&H1D) + "H" + CHR$ (3) ;
GOSUB BC
END
BC :
LPRINT CHR$ (&H1D) + "k" ;
LPRINT CHR$ (4) ; LPRINT "12" + CHR$(0) ;
LPRINT CHR$ (&HA) ;
RETURN
```

[Printing result]

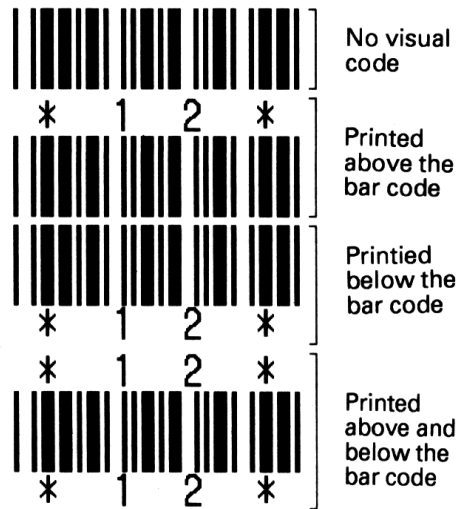

## GS f n

[Name] Selection of visual code font

[Code] <1D>H <66>H <n>

[Defined range] n = 0, 1



[Function] Selects the font for the visual code when printing the bar code.

The fonts that can be selected according to the n value are shown in the table below.

n	Font
0	Font 1
1	Font 2

The visual code is the showing of the bar code in characters so that the bar code can be read visually.

[Items requiring caution]

The visual code will be printed at the position specified using GS H.

[Initial value] n = 0

[Reference] GS H

[Program example]

```
LPRINT CHR$(&H1D) + "h" + CHR$(50) ;
LPRINT CHR$ (&H1D) + "H" + CHR$ (2) ;
LPRINT CHR$ (&H1D) + "f" + CHR$ (0) ;
GOSUB BC
LPRINT CHR$ (&H1D) + "f" + CHR$ (1)
GOSUB BC
END
```

[Printing result]

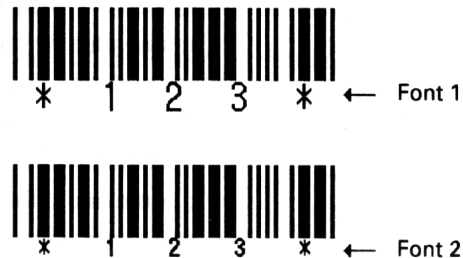

BC :

```
LPRINT CHR$(&H1D) + "k" ;
LPRINT CHR$ (4) ;
LPRINT "123" + CHR$ (0) ;
LPRINT CHR$ (&HA) ;
RETURN
```

---

**GS c**

---

[Name]                    Printing of counter

[Code]                    <1D>H <63>H

[Function]                Prints the consecutive number counter.

- Sets the current numerical value of the counter in the print buffer as printing data (line of characters), and then counts up or counts down the counter depending on the counting mode that has been set.

[Items requiring caution]

- The format of the data when it is set in the print buffer will be according to the GS C 0 command.
- The counting mode will be according to the GS C 1 or GS C ; commands.

When counting up:

- If the counter value set using this command is outside the operation range of the counter set using the GS C 1 or GS C ; commands the counter will be forcibly changed to the minimum value by the execution of GS c.

When counting down:

- If the counter value set using this command is outside the operation range of the counter set using the GS C 1 or GS C ; commands, the counter will be forcibly changed to the maximum value by the execution of GS c.

[Program example]

```

LPRINT CHR$ (&H1D) + "C0" ;           CNT :
LPRINT CHR$(0) + CHR$(0) ;           FOR I=1 TO 5
GOSUB CNT                             LPRINT CHR$(&H1D) + "c" ;
LPRINT CHR$ (&H1D) + "C0" ;           NEXT I
LPRINT CHR$ (1) + CHR$ (0) ;           LPRINT CHR$ (&HA) ;
GOSUB CNT                             RETURN
LPRINT CHR$ (&H1D) + "C0" ;
LPRINT CHR$ (3) + CHR$ (0) :
GOSUB CNT
LPRINT CHR$ (&H1D) + "C0" ;
LPRINT CHR$(3) + CHR$(1) ;
GOSUB CNT
LPRINT CHR$(&H1D) + "C0" ;
LPRINT CHR$(3) + CHR$(2) ;
GOSUB CNT
END
    
```

[Printing result]

```

12345 ←————— When m = 0 and n = 0, the count will be from 1 to 5.
67890 ←————— When m = 1 and n = 0, the count will be from 6 to 10.
 11 12 13 14 15 ← When m = 3 and n = 0, the count will be from 11 to 15.
016017018019020 ← When m = 3 and n = 1, the count will be from 16 to 20.
21 22 23 24 25 ← When m = 3 and n = 2, the count will be from 21 to 25.
    
```

## GS C O m n

[Name]                      Setting of the numbering printing mode

[Code]                      <1D>H <43>H <30>H <m> <n>

[Defined ranges]             $0 \leq m \leq 5$

$0 \leq n \leq 2$

- [Function] Sets the printing mode of the numbering (consecutive numbering counter).
- m indicates the number of figures for printing.
    - m = 0 Only the actual number of figures are printed. In this case, n will have no meaning.
    - m = 1~5 This is the maximum number of figures for printing.  
If the number of figures of the counter value is greater than number of figures specified by this command, the last m figures of the counter value will be printed.
  - n specifies the printing position inside the number of figures for printing.
    - n = 0 Printing will be carried out from the right end. When the value has less than the specified number of figures, the empty places will become spaces.
    - n = 1 Printing will be carried out from the right end. When the value has less than the specified number of figures, the empty places will become 0.
    - n = 2 Printing will be carried out from the left end. Spaces will be added to the right side of the value in order to make up the specified number of figures.

## [Items requiring caution]

If either m or n is outside the defined range, the setting will be invalid

[Initial value] m = 0

[Reference] GS C 1, GS C 2, GS c, GS C ;

[Program example] [Printing result]

Refer to the program example and the printing result for GS c on page 87.

---

**GS C I n1 n2 n3 n4 n5 n6**

---

[Name]                      Setting of the numbering counting mode (A)

[Code]                      <1D>H <43>H <31>H <n1> <n2> <n3> <n4> <n5> <n6>

[Defined ranges]             $0 \leq n1 \leq 255$

$0 \leq n2 \leq 255$

$0 \leq n3 \leq 255$

$0 \leq n4 \leq 255$

$0 \leq n5 \leq 255$

$0 \leq n6 \leq 255$

[Function]                      Sets the numbering mode (consecutive numbering counter).

Initial value of the counter =  $n1 + n2 \times 256$  ( $n1$  is the remainder and  $n2$  is the quotient)

Final value of the counter =  $n3 + n4 \times 256$  ( $n3$  is the remainder and  $n4$  is the quotient)

When counting up:

- When  $n1 + n2 \times 256 < n3 + n4 \times 256$  and  $n5 \neq 0$  and  $n6 \neq 0$ , counting up will be carried out.
- $n1 + n2 \times 256$  will be the minimum value of the counter, and  $n3 + n4 \times 256$  will be the maximum value of the counter.

When counting down:

- When  $n1 + n2 \times 256 > n3 + n4 \times 256$  and  $n5 \neq 0$  and  $n6 \neq 0$ , counting down will be carried out.
- $n1 + n2 \times 256$  will be the maximum value of the counter, and  $n3 + n4 \times 256$  will be the minimum value of the counter.

To stop the counter:

- When  $n1 + n2 \times 256 = n3 + n4 \times 256$  or  $n5 = 0$  or  $n6 = 0$ , the counting will stop.
- $n5$  indicates the step amount during the counting up or counting down.
- $n6$  indicates the number of repetitions while the counter remains fixed.

## [Items requiring caution]

When this command has been executed, the counter that indicates the number of repetitions specified by n6 will be cleared.

When counting up:

- When the result of the counting up exceeds the maximum value, the counting up will start counting from the minimum value once again.

When counting down:

- When the result of the counting down becomes smaller than the minimum value, the counting down will start counting from the maximum value once again.

## [Initial value]

$n1 + n2 \times 256 = 1$ ,  $n3 + n4 \times 256 = 65535$ ,  $n5 = 1$ ,  $n6 = 1$

## [Reference]

GS C 0, GS C 2, GS c, GS C ;

[Program example]

```
LPRINT CHR$ (&H1D) + "C0" ;
LPRINT CHR$(3) + CHR$(0) ;
LPRINT CHR$ (&H1D) + "C1" ;
LPRINT CHR$(50) + CHR$(0) ;
LPRINT CHR$(0) + CHR$ (0) ;
LPRINT CHR$(5) + CHR$(2) ;
LPRINT CHR$(&H1D) + "C2" ;
LPRINT CHR$ (50) + CHR$(0) ;
GOSUB CNT
LPRINT CHR$ (&H1D) + "C2" ;
LPRINT CHR$ (5) + CHR$(0) ;
GOSUB CNT
END
CNT :
FOR I=1 TO 6
LPRINT CHR$(&H1D) + "c" ;
NEXT I
LPRINT CHR$ (&HA) ;
RETURN
```

[Printing result]

```
50 50 45 45 40 40 ← Counter printing when the countdown is in the
5 5 0 0 50 50 ← range of 0 to 50, set in steps of 5, and repeated 2
times from a starting value of 50.
Counter printing when the countdown is in the
range of 0 to 50, set in steps of 5, and repeated 2
times from a starting value of 5.
```

**GS C 2 n1 n2**

[Name]	Setting of the numbering counter
[Code]	<1D>H <43>H <32>H <n1> <n2>
[Defined ranges]	$0 \leq n1 \leq 255$ $0 \leq n2 \leq 255$
[Function]	<p>Sets the numbering value (consecutive numbering counter).</p> <p>The value of the counter will be <math>n1 + n2 \times 256</math></p>
[Items requiring caution]	<p>When this command has been executed, the internal counter that counts the number of repetitions while the counter value remains fixed will be cleared.</p> <p>When counting up:</p> <ul style="list-style-type: none"> <li>• When the counter value set using this command is outside the operating range of the counter set by GS C 1 or GS C ;, the counter will be forcibly changed to the maximum value by the execution of GS c.</li> </ul> <p>When counting down:</p> <ul style="list-style-type: none"> <li>• When the counter value set using this command is outside the operating range of the counter set by GS C 1 or GS C ;, the counter will be forcibly changed to the maximum value by the execution of GS c.</li> </ul>
[Initial value]	$n1 + n2 \times 256 = 1$
[Reference]	GS C 0, GS C 1 GS c, GS C ;
[Program example]	[Printing result]
Refer to the program example and the printing result for GS C 1 on page 91.	



**GS C ; N1 ; N2 ; N3 ; N4 ; N5 ;**

[Name]	Setting of the numbering counting mode (B)
[Code]	$\langle 1D \rangle H \langle 43 \rangle H \langle 3B \rangle H \langle N1 \rangle \langle 3B \rangle H \langle N2 \rangle \langle 3B \rangle H \langle N3 \rangle$ $\langle 3B \rangle H \langle N4 \rangle \langle 3B \rangle H \langle N5 \rangle \langle 3B \rangle H$ * $\langle N1 \rangle \sim \langle N5 \rangle$ are received BY character code.
[Defined ranges]	$0 \leq N1 \leq 65535$ $0 \leq N2 \leq 65535$ $0 \leq N3 \leq 255$ $0 \leq N4 \leq 255$ $0 \leq N5 \leq 65535$
[Function]	<p>Sets the numbering mode (consecutive numbering counter), and sets the counter value.</p> <p>When counting up:</p> <ul style="list-style-type: none"> <li>• When <math>N1 &lt; N2</math> and <math>N3 \neq 0</math> and <math>N4 \neq 0</math>, counting up will be carried out.</li> <li>• <math>N1</math> will be the minimum value of the counter, and <math>N2</math> will be the maximum value of the counter.</li> </ul> <p>When counting down:</p> <ul style="list-style-type: none"> <li>• When <math>N1 &gt; N2</math> and <math>N3 \neq 0</math> and <math>N4 \neq 0</math>, counting down will be carried out.</li> <li>• <math>N1</math> will be the maximum value of the counter, and <math>N2</math> will be the minimum value of the counter.</li> </ul> <p>To stop the counter:</p> <ul style="list-style-type: none"> <li>• When <math>N1 = N2</math> or <math>N3 = 0</math> or <math>N4 = 0</math>, the counting will stop.</li> <li>• <math>N3</math> indicates the step amount during the counting up or counting down.</li> <li>• <math>N4</math> indicates the number of repetition while the counter remains fixed.</li> <li>• <math>N5</math> indicates the counter value.</li> </ul>

## [Items requiring caution]

- When this command has been executed, the internal counter that counts the number of repetitions while the counter value remains fixed will be cleared.
- It will be possible to omit any of the N1~N5 values. In this situation, the values of the omitted parameters will not be changed and will remain set at their previous values.
- For each of the N1~N5 values it is forbidden to include characters that are not '0'~'9'.
- If an incorrect format is used, this parameter setting will be invalid, and the following data will be processed as ordinary data.

## When counting up:

- When the result of the counting up exceeds the maximum value, the counting up will start counting from the minimum value once again.
- When the counter value set using N5 is outside the operating range of the counter, the counter will be forcibly changed to the minimum value by the execution of GS c.

## When counting down:

- When the result of the counting down becomes smaller than the minimum value, the counting down will start counting from the maximum value once again.
- When the counter value set using N5 is outside the operating range of the counter, the counter will be forcibly changed to the maximum value by the execution of GS c.

## [Initial value]

N1 = 1, N2 = 65535, N3 = 1, N4 = 1, N5 = 1

## [Reference]

GS C 0, GS C 1, GS C 2, GS c

[Program example]

```
LPRINT CHR$ (&H1D) + "C0" ;
LPRINT CHR$ (3) + CHR$ (0) ;
LPRINT CHR$ (&H1D) + "C;" ;
LPRINT "50;0;5;2;50;" ;
GOSUB CNT
LPRINT CHR$(&H1D) + "C;" ;
LPRINT "*50;0;5;2;5;" ;
GOSUB CNT
END
CNT :
FOR I=1 TO 6
LPRINT CHR$(&H1D) + "c" ;
NEXT I
LPRINT CHR$ (&HA) ;
RETURN
```

[Printing result]

```
50 50 45 45 40 40 ← Counter printing when the countdown is in the
5 5 0 0 50 50 ← range of 0 to 50, set in steps of 5, and repeated 2
times from a starting value of 50.
Counter printing when the countdown is in the
range of 0 to 50, set in steps of 5, and repeated 2
times from a starting value of 5.
```

**GS \* n1 n2 [d] n1 x n2 x 8**

[Name] Definition of the downloading/bit image

[Code] <1D>H <2A>H <n1> <n2> [<d>] n1 x n2 x 8

[Defined ranges] 0 ≤ n1 ≤ 255  
0 ≤ n2 ≤ 48  
n1 x n2 ≤ 1311

[Function] Specifies the downloading/bit image using the number of dots specified by n1 and n2. The number of dots in the horizontal direction will be  $n1 \times 8$ , and the number of dots in the vertical direction will be  $n2 \times 8$ . d is the bit image data. After the downloading/bit image has been defined, the definition will be effective until redefinition, or until the ESC @ or ESC & commands are executed, or until the power is switched off .

[Items requiring caution] The relationship between the bit image data and the defining dots is shown in the figure below. It will not be possible to define downloading characters and downloading/bit images at the same time. By executing this command, the contents of the defined downloading characters will be cleared.

[Reference] GS /

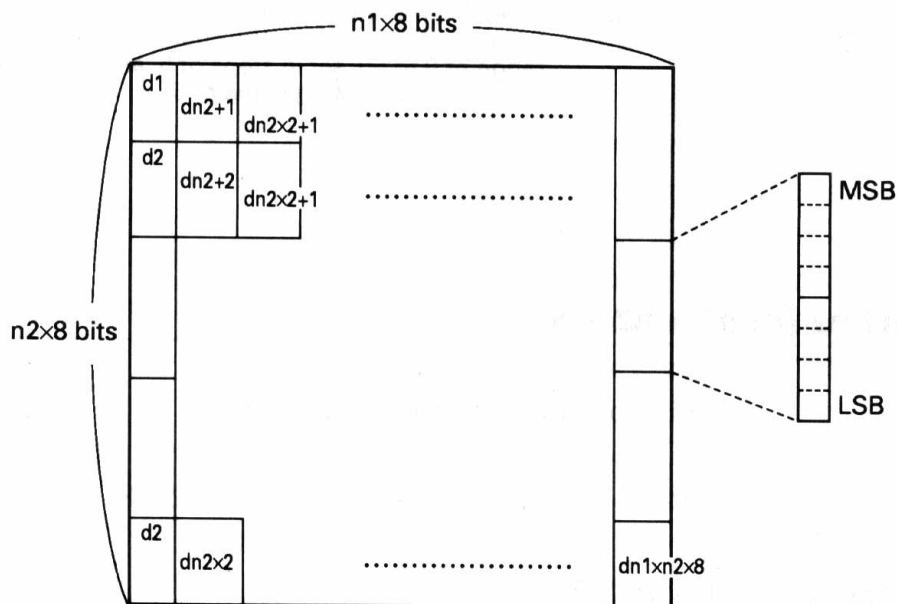

[Program example]

```
GOSUB IMG
LPRINT CHR$ (&H1D) + "/" + CHR$ (0) ;
LPRINT CHR$ (&H1D) + "/" + CHR$ (1) ;
LPRINT CHR$ (&H1D) + "/" + CHR$ (2) ;
LPRINT CHR$ (&H1D) + "/" + CHR$ (3) ;
END
IMG :
n1=10:n2=5
LPRINT CHR$ (&H1D) + "*" ;
LPRINT CHR$(n1) + CHR$(n2) ;
FOR J=1 TO n1*8
FOR I=1 TO n2
LPRINT CHR$(J) ;
NEXT I
NEXT J
RETURN
```

[Printing result]

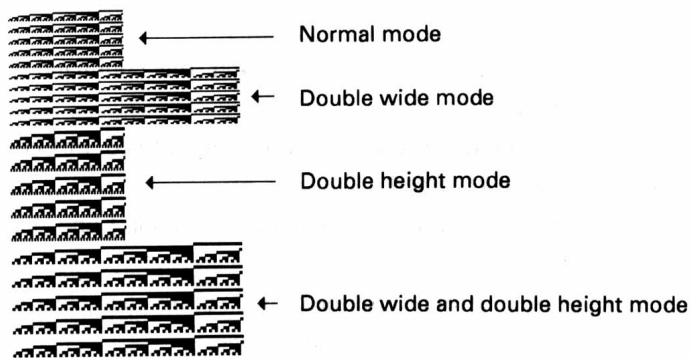

**GS / m**

[Name] Printing of the downloading/bit image

[Code] <1D>H <2F>H <m>

[Defined range]  $0 \leq m \leq 3$

[Function] Prints the downloading/bit image using the mode specified by m. The modes specified by m are shown in the following table.

m	Mode name	Dot density in the vertical direction	Dot density in the horizontal direction
0	Normal mode	203DPI	203DPI
1	Double wide mode	203DPI	101DPI
2	Double height mode	101DPI	203DPI
3	Double wide and Double height mode	101DPI	101DPI

[Items requiring caution]

If there is data present in the print buffer, this command will be disregarded.

If the downloading/bit image has not been defined, this command will be disregarded.

Parts of the downloading/bit image that exceed the 1 line length will not be printed.

It will not be possible to define downloading characters and downloading/bit images at the same time.

[Initial value] Not defined

[Reference] GS \*

[Program example] [Printing result]

Refer to the program example and the printing result for GS \* on page 97.

**GS :**

[Name] Starting/finishing of the macro defining

[Code] <1D>H <3A>H

[Function] Specifies the starting or finishing of the macro defining.  
The receiving of this command while the macro defining is being carried out will have the meaning of finishing the macro defining,

[Items requiring caution] Up to 2048 bytes of contents may be defined by the macro. Those parts of the macro in excess of 2048 bytes can not be defined.  
The defined contents will not be cleared even if the ESC @ (printer initialization) command is executed.  
Accordingly, the ESC @ command may be included in the contents for macro defining.  
Normal printing operations can be carried out even when macro defining is taking place.

[Initial value] The macro is not defined

[Reference] GS ^

## [Program example]

```
LPRINT CHR$ (&H1D) + " : " ;
LPRINT "+---+" + CHR$ (&HA) ;
LPRINT " | " ; LPRINT CHR$(&H1D) + "c" ;
LPRINT " | " + CHR$(&HA) ;
LPRINT "+---+" + CHR$ (&HA) ;
LPRINT CHR$(&H1D) + " : " ;
LPRINT CHR$ (&H1D) + "^" ;
LPRINT CHR$(2) + CHR$(10) ;
LPRINT CHR$ (0) ;
```

[Printing result]

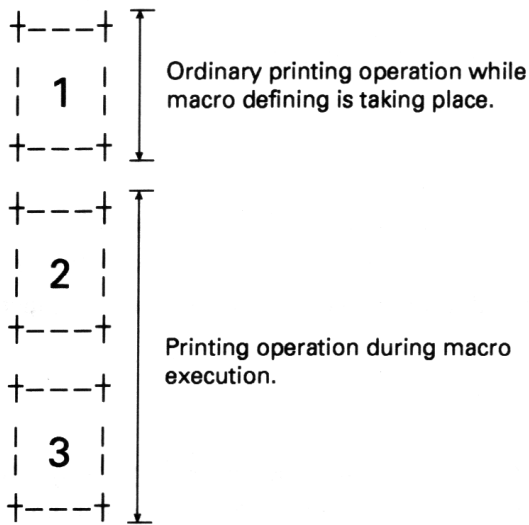

### GS ^ ^n1 n2 n3

[Name]	Macro execution
[Code]	<1D>H <5E>H <n1> <n2> <n3>
[Defined ranges]	$0 \leq n1 \leq 255$ $0 \leq n2 \leq 255$ $0 \leq n3 \leq 1$
[Function]	<p>Executes the contents defined by the macro.</p> <p>n1 indicates the number of times of the macro execution.</p> <p>n2 indicates the waiting time during the macro execution.</p> <p>Each one time the execution is carried out, there will be a waiting time of <math>n2 \times 100</math>msecs.</p> <p>n3 indicates the macro execution mode.</p> <p>When <math>n3 = 0</math>, successive execution will be carried out.</p> <p>The macro will be successively executed for the number of times specified by n1, allowing the time interval specified by n2 between each execution.</p>



When  $n3 = 1$ , execution will be carried out each time the LF switch is pressed.

After waiting for the time specified by  $n2$ , the alarm LED will flash and the printer will wait for the LF switch to be pressed. When the LF switch is pressed, the macro will be executed one time. This operation will be repeated for the number of times specified by  $n1$ .

[Items requiring caution]

The receiving of this command while the macro defining is being carried out will have the meaning of stopping the macro defining.

At this time, the defining contents will be cleared. If the macro has not yet been defined, or if  $n1 = 1$ , no execution will take place.

During the macro execution when  $n3 = 1$ , it will not be possible to carry out paper feeding using the LF switch.

[Initial value]                      Not defined

[Reference]                          GS :

[Program example]                      [Printing result]

Refer to the program example and the printing result for GS : on page 99 - 100.

## GS <

---

[Name]                                  Initialization of the printer mechanism

[Code]                                  <1D>H <3C>H

[Function]                              Carries out the moving to the top of the label.

[Items requiring caution]

- This command will only be effective when label printing has been selected.
- Because the moving to the top of the label passes over the first label in order to read in the label length and label interval, the printing position will be the top of the second label.
- Since the maximum length of the label is assumed to be 100 mm, an error will occur if the label exceeds 100 mm in length.

[Program example]

```
LPRINT CHR$ (&H1D) + "<" ;
```

## GS A m n

---

[Name] Correction of the label top position

[Code] <1D>H <41>H <m> <n>

[Defined ranges]  $0 \leq m \leq 255$   
 $0 \leq n \leq 255$

[Function] Sets a correction amount with regard to the default position that is taken as the label top position.

- m indicates the direction of the correction.

When  $m = \langle \text{*****}0 \rangle B$ , the correction will be applied to the label top position in the forward direction.

When  $m = \langle \text{*****}1 \rangle B$ , the correction will be applied to the label top position in the reverse direction.

- In indicates the correction amount, and this correction amount should be in 1/203 inch units.

[Items requiring caution]

- It will not be possible to move to a label position that exceeds the top edge of the label.  
 In a situation where a label

top correction amount is specified that will exceed the top edge of the label, the position will be set as the top edge of the label.

- It will not be possible to set the length that can be printed on one label to a value of less than 2/6 inch. In a situation where the setting is less than 2/6 inch, the setting will become 2/6 inch.
- The initial value of the label top position will be approximately 1.5 mm from the label top edge position.
- This command will only be effective when the label printing has been set.
- This command will be only be effective immediately after moving to the top of the label. (After paper feeding using the FF, GS, FF, GS <commands or LF switch, or after switching the power on.)
- Due to the flexing and the range of differences in the paper, the moving to the top of the label may have a  $\pm 1$  mm shift in position. Adequate consideration should be taken of this fact when carrying out the setting.

[Initial value]            1.5 mm

[Reference]                FF, GS FF

[Program example]

```
LPRINT CHR$(&H1D) + "A" ;
LPRINT CHR$(0) + CHR$(0) ;
LPRINT "AAAAA" + CHR$(&HC) ;
LPRINT CHR$(&H1D) + "A" ;
LPRINT CHR$(1) + CHR$(8) ;
LPRINT "AAAAA" + CHR$(&HC) ;
LPRINT CHR$(&H1D) + "A" ;
LPRINT CHR$ (0) + CHR$ (20) ;
LPRINT "AAAAA" + CHR$(&H) ;
```

[Printing result]

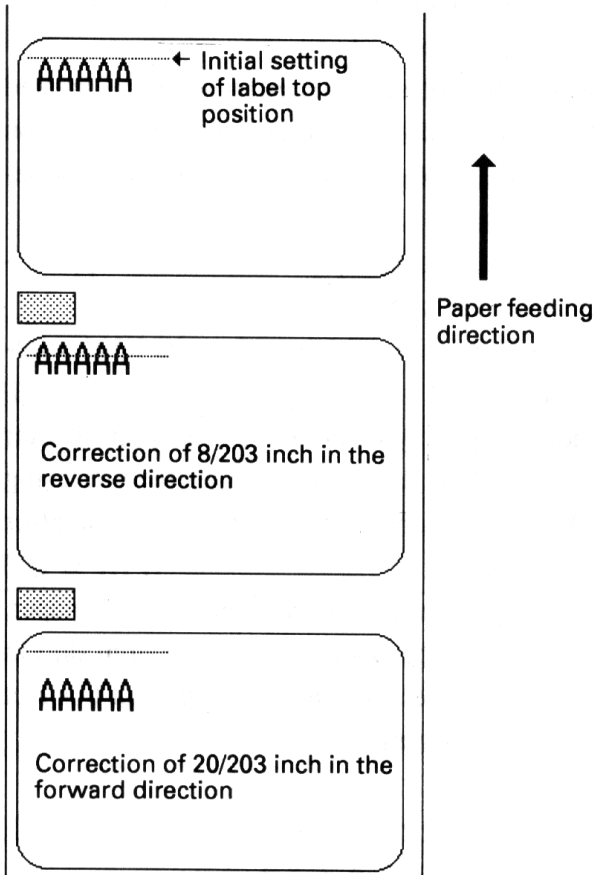

## GS R n

[Name]                      Specifying/releasing of the black/white inverted characters

[Code]                      <1D>H <52>H <n>

[Function]                      Specifies or releases the black/white inverted characters.

- When n = <\*\*\*\*\*0>B, the black/white inverted characters will be released.
- When n = <\*\*\*\*\*1>B, the black/white inverted characters will be specified.

This command will be effective for all character types.

[Initial value]                      n = 0

[Program example]

```
LPRINT CHR$(&H1D) + "R" + CHR$ (0) ;
LPRINT "AAAAA" ;
LPRINT CHR$(&H1D) + "R" + CHR$(1) ;
LPRINT "AAAAA" + CHR$ (&HA) ;
```

[Printing result]

Black/white inversion released

Black/white inversion specified

### 8.3 Character code tables

#### 8.3.1 Page 0 (International character set: When U.S.A characters have been selected)

L \ H	Binary	0000	0001	0010	0011	0100	0101	0110	0111	1000	1001	1010	1011	1100	1101	1110	1111
Binary	Hexa-decimal	0	1	2	3	4	5	6	7	8	9	A	B	C	D	E	F
0000	0	NUL		(SP)	0	@	P	'	p	Ç	É	á	⌘	⌘	⌘	α	≡
0001	1		XON	!	1	A	Q	a	q	ü	æ	í	⌘	⌘	⌘	β	±
0010	2			"	2	B	R	b	r	é	Æ	ó	⌘	⌘	⌘	Γ	≥
0011	3		XOFF	#	3	C	S	c	s	â	ô	ú			⌘	π	≤
0100	4			\$	4	D	T	d	t	ä	ö	ñ		—	⌘	Σ	∫
0101	5			%	5	E	U	e	u	à	ò	Ñ	≡	+	⌘	σ	∫
0110	6			&	6	F	V	f	v	å	û	⌘	⌘	⌘	⌘	μ	÷
0111	7			'	7	G	W	g	w	ç	ù	⌘	⌘	⌘	⌘	τ	≈
1000	8			(	8	H	X	h	x	ê	ÿ	¿	⌘	⌘	⌘	Φ	°
1001	9	HT		)	9	I	Y	i	y	ë	Ö	⌘	⌘	⌘	⌘	θ	•
1010	A	LF		*	:	J	Z	j	z	è	Ü	⌘	⌘	⌘	⌘	Ω	·
1011	B		ESC	+	;	K	[	k	{	ï	¢	½	⌘	⌘	■	δ	√
1100	C	FF	FS	,	<	L	\	l	;	î	£	¼	⌘	⌘	■	∞	∞
1101	D	CR	GS	-	=	M	]	m	}	ì	¥	¡	⌘	=	■	φ	²
1110	E			.	>	N	^	n	~	Ä	ƒ	«	⌘	⌘	■	ε	■
1111	F			/	?	O	_	o	(SP)	Å	f	»	⌘	⌘	■	∩	(SP)

8.3.2 Page 1 (International character set: When U.S.A characters have been selected)

L \ H	Binary	0000	0001	0010	0011	0100	0101	0110	0111	1000	1001	1010	1011	1100	1101	1110	1111
Binary	Hexa-decimal	0	1	2	3	4	5	6	7	8	9	A	B	C	D	E	F
0000	0	NUL		(SP)	0	@	P	'	p	-	⊥	(SP)	-	タ	ミ	=	×
0001	1		XON	!	1	A	Q	a	q	-	⊥	。	ア	チ	ム	フ	円
0010	2			"	2	B	R	b	r	-	⊥	「	イ	ツ	メ	≠	年
0011	3		XOFF	#	3	C	S	c	s	-	⊥	」	ウ	テ	モ	≠	月
0100	4			\$	4	D	T	d	t	-	⊥	,	エ	ト	ヤ	▲	日
0101	5			%	5	E	U	e	u	-	⊥	.	オ	ナ	ユ	▲	時
0110	6			&	6	F	V	f	v	-	⊥	ヲ	カ	ニ	ヨ	▲	分
0111	7			'	7	G	W	g	w	-	⊥	ヲ	キ	ヌ	ラ	▲	秒
1000	8			(	8	H	X	h	x	⊥	⊥	イ	ク	ネ	リ	♠	〒
1001	9	HT		)	9	I	Y	i	y	⊥	⊥	ウ	ケ	ノ	ル	♥	市
1010	A	LF		*	:	J	Z	j	z	⊥	⊥	エ	コ	ハ	レ	♦	区
1011	B		ESC	+	;	K	[	k	{	⊥	⊥	オ	サ	ヒ	ロ	♣	町
1100	C	FF	FS	,	<	L	\	l	;	⊥	⊥	ヤ	シ	フ	ワ	●	村
1101	D	CR	GS	-	=	M	]	m	}	⊥	⊥	ユ	ス	ハ	ン	○	人
1110	E			.	>	N	^	n	~	⊥	⊥	ヨ	セ	ホ	°	/	■
1111	F			/	?	O	_	o	(SP)	+	⊥	ッ	ソ	マ	°	\	(SP)

## 8.3.3 International character sets

	Country name	ASCII (Hexadecimal notation)											
		2 3	2 4	4 0	5 B	5 C	5 D	5 E	6 0	7 B	7 C	7 D	7 E
0	U.S.A.	#	\$	@	[	\	]	^	'		:	}	~
1	France	#	\$	à	°	ç	§	^	'	é	ù	è	¨
2	Germany	#	\$	§	Ä	Ö	Ü	^	'	ä	ö	ü	ß
3	U.K.	£	\$	@	[	\	]	^	'		:		~
4	Denmark I	#	\$	@	Æ	Ø	Å	^	'	æ	ø	å	~
5	Sweden	#	¤	É	Ä	Ö	Å	Ü	é	ä	ö	å	ü
6	Italy	#	\$	@	°	\	é	^	ù	à	ò	è	ì
7	Spain	Pt	\$	@	¡	Ñ	¿	^	'	¨	ñ		~
8	Japan	#	\$	@	[	¥	]	^	'		:		~
9	Norway	#	¤	É	Æ	Ø	Å	Ü	é	æ	ø	å	ü
1 0	Denmark II	#	\$	É	Æ	Ø	Å	Ü	é	æ	ø	å	ü



## 9. EXTERNAL DIMENSION

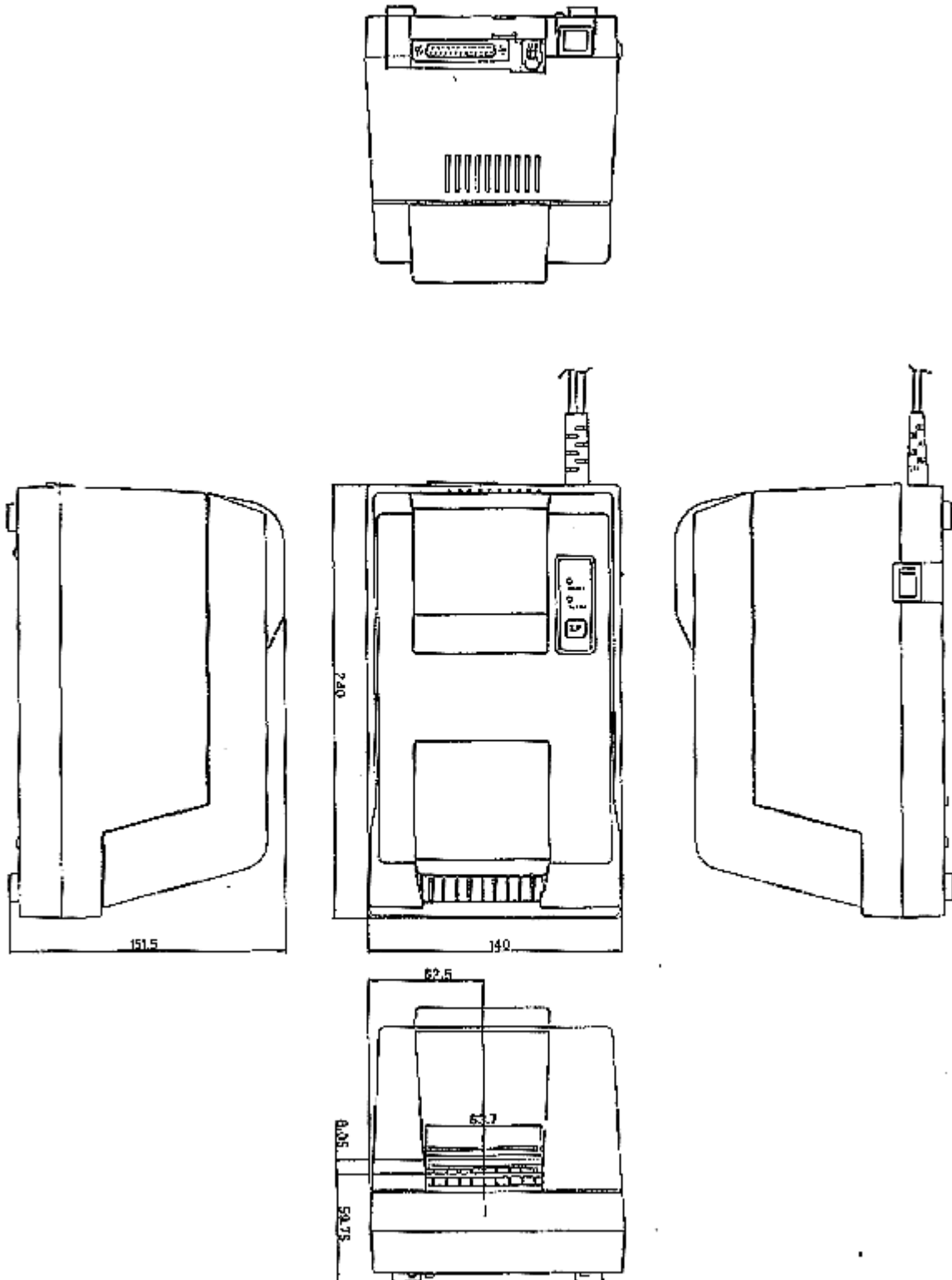

# Japan CBM Corporation

Information Systems Division — CBM Bldg., 5-68-10, Nakano, Nakano-ku, Tokyo 164-0001, Japan  
Head Office ————— Tel: (+81-3) 5345-7540 Fax: (+81-3) 5345-7541

**70903341** 06-980811-0500-0352-0128-3000 Printed in Japan

## Free Manuals Download Website

<http://myh66.com>

<http://usermanuals.us>

<http://www.somanuals.com>

<http://www.4manuals.cc>

<http://www.manual-lib.com>

<http://www.404manual.com>

<http://www.luxmanual.com>

<http://aubethermostatmanual.com>

Golf course search by state

<http://golfingnear.com>

Email search by domain

<http://emailbydomain.com>

Auto manuals search

<http://auto.somanuals.com>

TV manuals search

<http://tv.somanuals.com>