



***POWER SYSTEM***

**clarion**  
CAR AUDIO & BEYOND

***APX600.5***

**OPERATION  
INSTALLATION  
MANUAL**

## **INTRODUCTION**

The Clarion APX600.5 is a full-featured five-channel amplifier. It comes with the following features:

- Full frequency response with low distortion and exceptional signal to noise performance
- Advanced circuit design for flexibility and operation of 5, 4 or 3 channel systems
- Independent front high pass & rear high / low / bandpass electronic crossovers, each with a 12dB per octave slope and full adjustment range (55Hz to 5.5kHz) to aid in audio system design
- Subwoofer electronic crossover with 12 or 24DB per octave slope and full adjustment range (55Hz to 550Hz)
- Variable bass boost circuit to reinforce low frequency signals that may be lost due to subwoofer enclosure design
- Adjustable input level controls (front, rear, and subwoofer) with ground loop isolation accepting a wide range of input signals
- Remote turn-on with “soft start” muting to prevent turn-on “thump”
- Pulse-width modulated (PWM) MOSFET power supply with low AM RFI and protection circuits for overheating and speaker shorts
- 2 ohm load capability to drive a variety of speaker systems
- Gold-plated input/output connectors
- Low profile, compact size for space limited installations
- Front and Rear High Level Inputs
- Front, Rear and Suwoofer gold-plated RCA Inputs
- Optional Remote Bass Control Available (BC1)

## **ABOUT THE MANUAL AND WARRANTY**

To start enjoying your new Clarion five-channel amplifier, please read the following instructions listed in this manual. Keep all instructions for future reference. Please fill out and send in the enclosed warranty card to protect your purchase and aid in warranty service. Also, **save your original sales receipt as proof of purchase.**

## **TABLE OF CONTENTS**

Description .....	3
Input Connections and Audio Controls .....	3
Connections for Power and Speakers .....	5
Crossover Selection Switches .....	5
Applications .....	7
Installation .....	11
Mounting Precautions .....	11
Wiring Precautions .....	11
Setting the Gain .....	13
Setting the Crossover .....	13
Setting the Bass Boost .....	13
Final System Check .....	14
Troubleshooting .....	14
Product Specs .....	15

## DESCRIPTION

The Clarion APX600.5 five channel car audio amplifier is an excellent choice for creating a variety of multi-channel sound systems. It features built-in system design flexibility that allows you to create a 3, 4, or 5 channel amplifier system with a flip of a switch. You can also configure the front, rear and subwoofer amplifier sections to drive a set of satellite speakers and/or subwoofer.

The built-in 12 dB per octave electronic crossover lets you custom tailor the sound of the front and rear channels, using two independent filters with adjustable crossover frequencies for high-pass or low-pass filtering.

The amplifier also uses an unregulated MOSFET power supply for superior control of output wattage. A toroid-coil transformer yields maximum power transfer with minimum heat loss. Careful circuit design keeps AM RFI at low levels, so you won't hear unwanted noise when the level is cranked up. Protection circuits safeguard the amplifier when overheating, speaker shorts or improper load conditions occur.

The main connections and controls are on the end panels and are easy to understand. System configuration switches and signal flow chart are on the bottom panel of the amplifier. Gold-plated RCA and barrier connectors are used to ensure the best electrical connection for your system.

## INPUT CONNECTIONS AND AUDIO CONTROL

The front panel of the APX600.5 contains connections for High / Low Level Inputs and Audio Adjustments as shown below.

Figure 1-

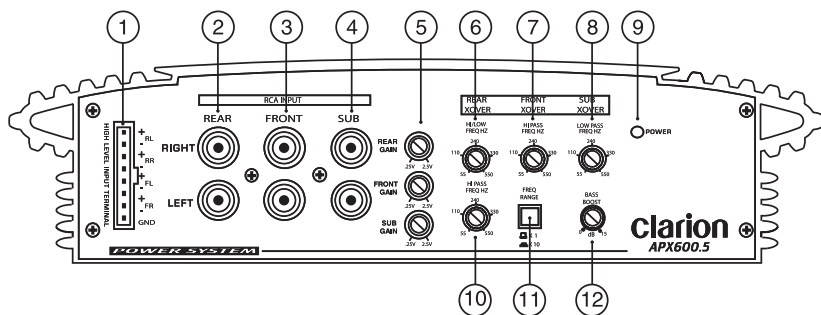

- |                                   |                                     |
|-----------------------------------|-------------------------------------|
| ① Speaker High Level Inputs       | ⑦ Front Hi Pass Frequency Control   |
| ② Rear RCA Input Jacks            | ⑧ Sub Low Pass Frequency Control    |
| ③ Front RCA Input Jacks           | ⑨ Power Indicator                   |
| ④ Sub RCA Input Jacks             | ⑩ Rear Hi Pass Frequency Control    |
| ⑤ Gain Controls                   | ⑪ Front Frequency Multiplier Switch |
| ⑥ Rear Hi / Low Frequency Control | ⑫ Subwoofer Bass Boost Control      |

- **Gold-Plated RCA Input Connectors** -The Input Connections are Gold-Plated RCA Jacks and are labeled as Right Front, Left Front, Right Rear, Left Rear, Right Sub and Left Sub.
- **Gain Controls** - The Gain Controls provide a wide adjustment range to accommodate output levels from any brand of source unit. Separate Front, Rear, and Sub Gain Controls allow you to set the nominal operating level of the amplifier. The amplifier ranges are 250mV to 2.5V for RCA inputs and 500mV to 5V for speaker level inputs.
- **Bass Boost Control** - The amplifier also features a “high-Q” (i.e. narrow frequency band) Bass Boost circuit for the subwoofer output. It acts much like an equalizer, with an adjustable gain (from 0 to +15dB) fixed at 45Hz. Use this feature to tune low-frequency audio response to compensate for a less than ideal subwoofer enclosure design. The added boost produces rich, full bass tones that are normally difficult to reproduce in the car audio environment. Note: If Bass Boost is undesired, set Bass Boost to 0dB.

## High-pass/Low-pass Filter Controls

- **Freq (Hz) Controls** - The front crossover frequency is fully adjustable between 55Hz and 5.5KHz (via the front crossover frequency multiplier). The rear crossover frequency is fully adjustable between 55Hz and 5.5 KHz (via the Rear Crossover Frequency Multiplier) for a wide range of crossover points. Use this feature, along with your speaker manufacturer’s specs to adjust to recommended crossover frequencies (see Applications on page 6.) NOTE: If either of the X-Over Mode Switches is set to FULL RANGE, varying the Freq (Hz) Control will produce no effect.
- **Front X-Over Frequency Multiplier Switch** - When engaged, this switch increases the crossover frequency of the front channels by a factor of 10. Example: If the Freq (Hz) dial is set for 240Hz, pushing in the Multiplier Switch changes the setting to 2400Hz.
- **Speaker Level Inputs** - These provide connections for a high-level stereo source. In addition, these connections are provided for installations where the source unit’s RCA outputs are unavailable such as OEM radios.

**WARNING:** When using the speaker (high-level) inputs, the Black wire must be grounded at the Radio. Failure to do this will result in noise and improper operation.

**CONNECTIONS FOR POWER AND SPEAKERS**

The rear panel of the APX600.5 contains power and speaker connections as shown below.

**Figure 2-**

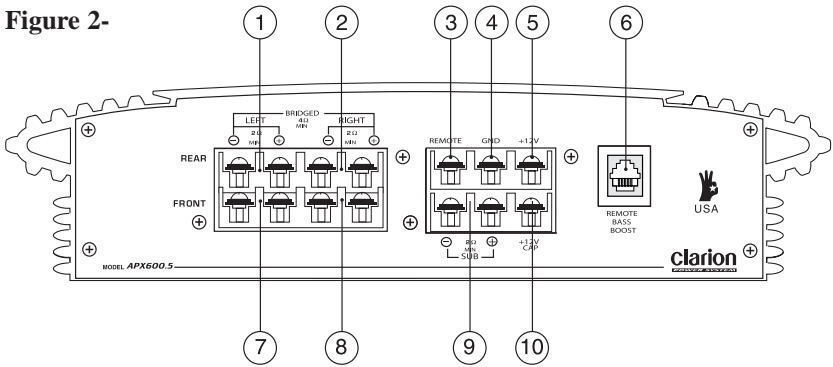

- ① Left Rear Speaker Output
- ② Right Rear Speaker Output
- ③ Remote Turn-on Input
- ④ Ground Input
- ⑤ Battery + 12v Input
- ⑥ Remote Sub Level Connector
- ⑦ Left Front Speaker Output
- ⑧ Right Front Speaker Output
- ⑨ Subwoofer Speaker Output
- ⑩ + 12 V Cap Input

**CROSSOVER SELECTION SWITCHES**

The bottom panel of the APX600.5 contains crossover selection switches as shown below.

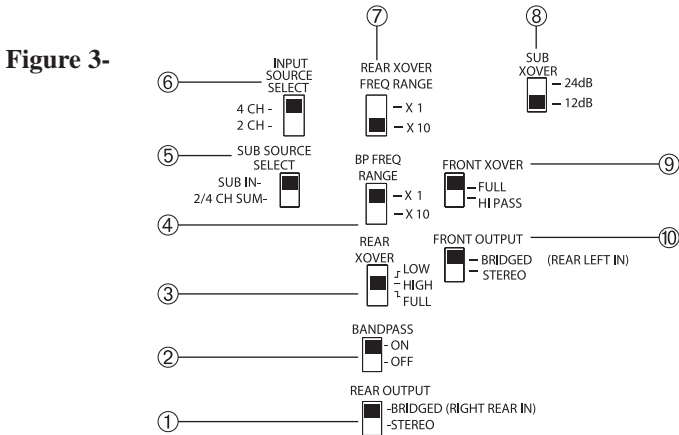

- ① Rear Output Mode Switch
- ② Band Pass Selection Switch
- ③ Rear X-Over Selection Switch
- ④ Band Pass Multiplier Switch
- ⑤ Sub Source Selection Switch
- ⑥ Input Source Selection Switch
- ⑦ Rear Crossover Multiplier Switch
- ⑧ Sub X-Over Slope Selection Switch
- ⑨ Front X-Over Selection Switch
- ⑩ Front Output Mode Switch

**CONNECTIONS**

## Flow Chart

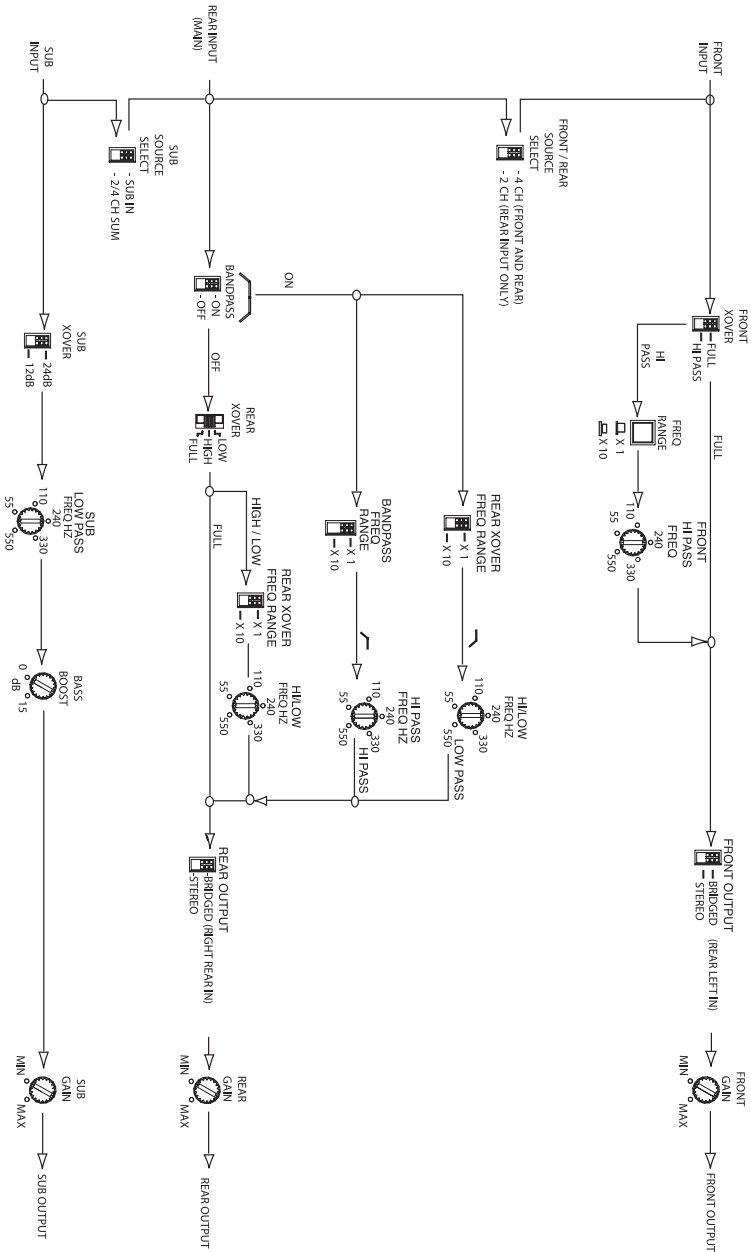
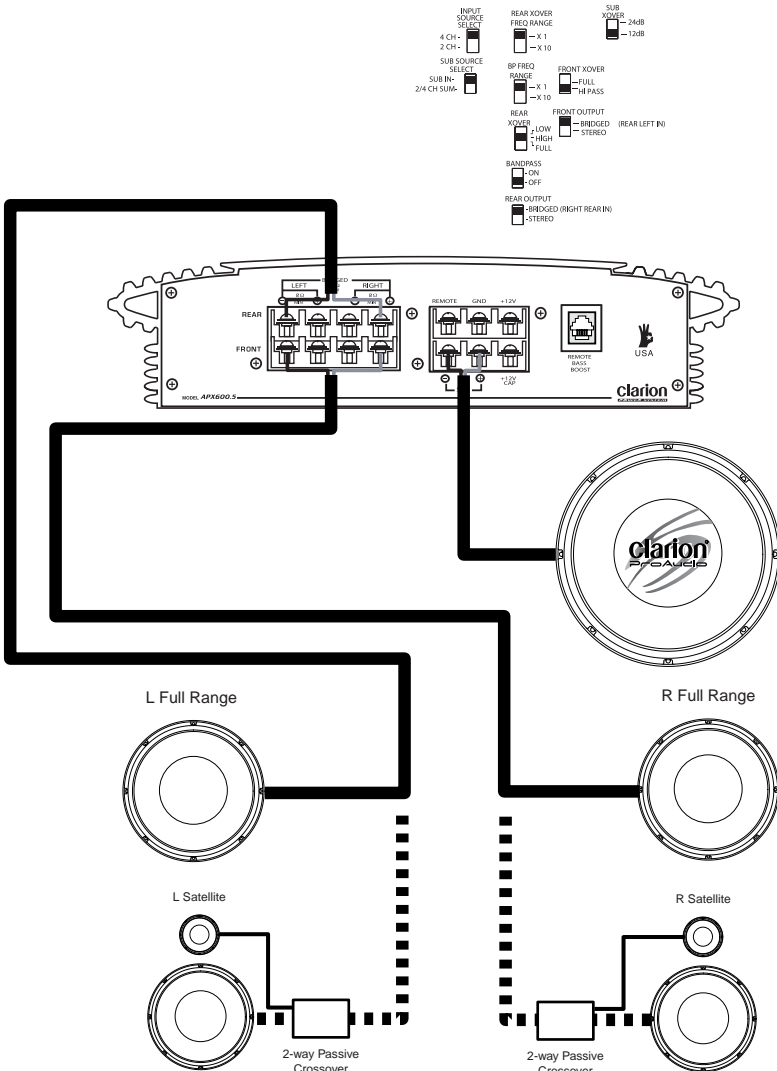

Figure 4 - Use this flow chart to set up the Crossover Switches

**APPLICATIONS**

The Clarion APX600.5 multi-channel car audio amplifier can be used in a variety of system applications. Enclosed are some example system layouts to help plan your own installation.

**3-Channel Mode**



**Figure 5** - In this application, the APX600.5 is used as a 3-channel amplifier to drive two full-range or Satellite speakers in stereo plus a subwoofer.

**APPLICATIONS**

## 5-channel System 2-Channels High-Pass, 2-Channels Band-Pass Plus Sub

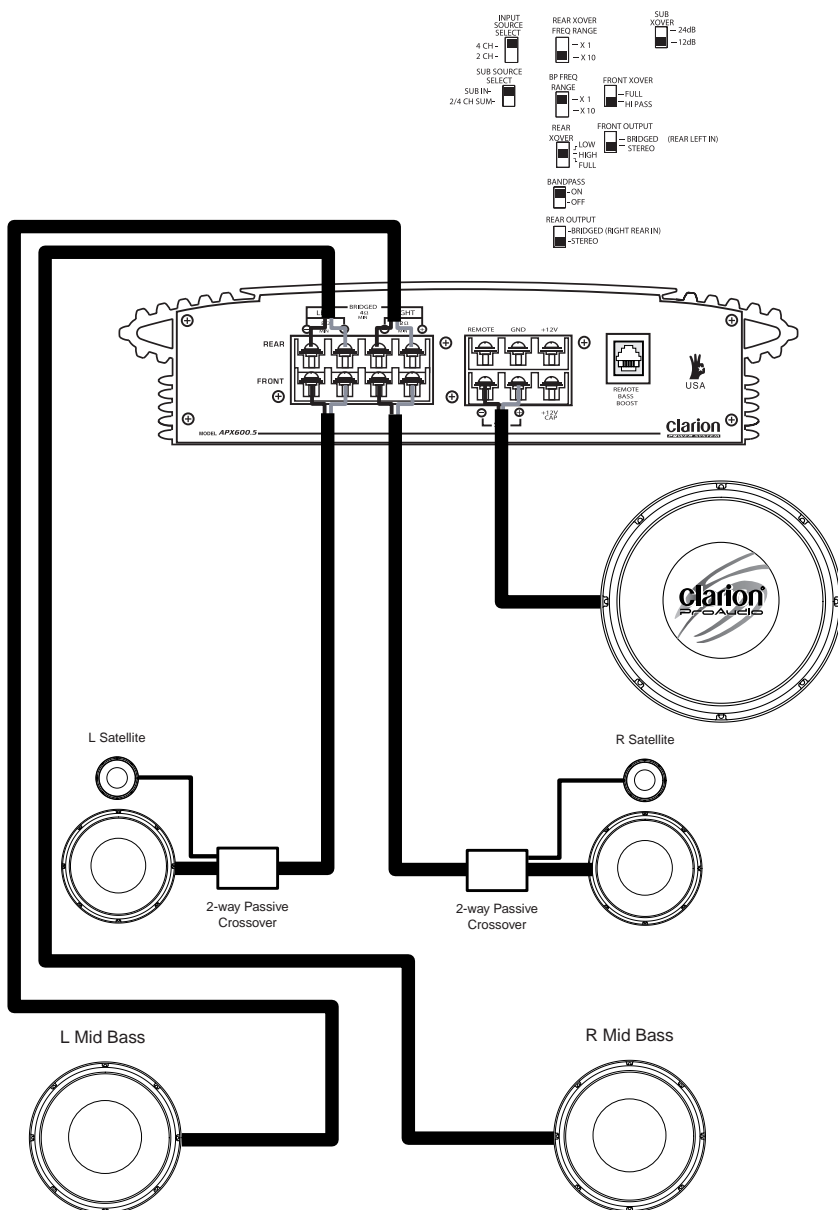

**Figure 6** - In this 5-channel system, the APX600.5 drives a pair of stereo satellites for the front and a pair of stereo mid bass for the rear plus a sub. Note the system configuration settings.



## 5-channel System 2-Channels High-Pass, 2-Channels Band-Pass Plus Sub

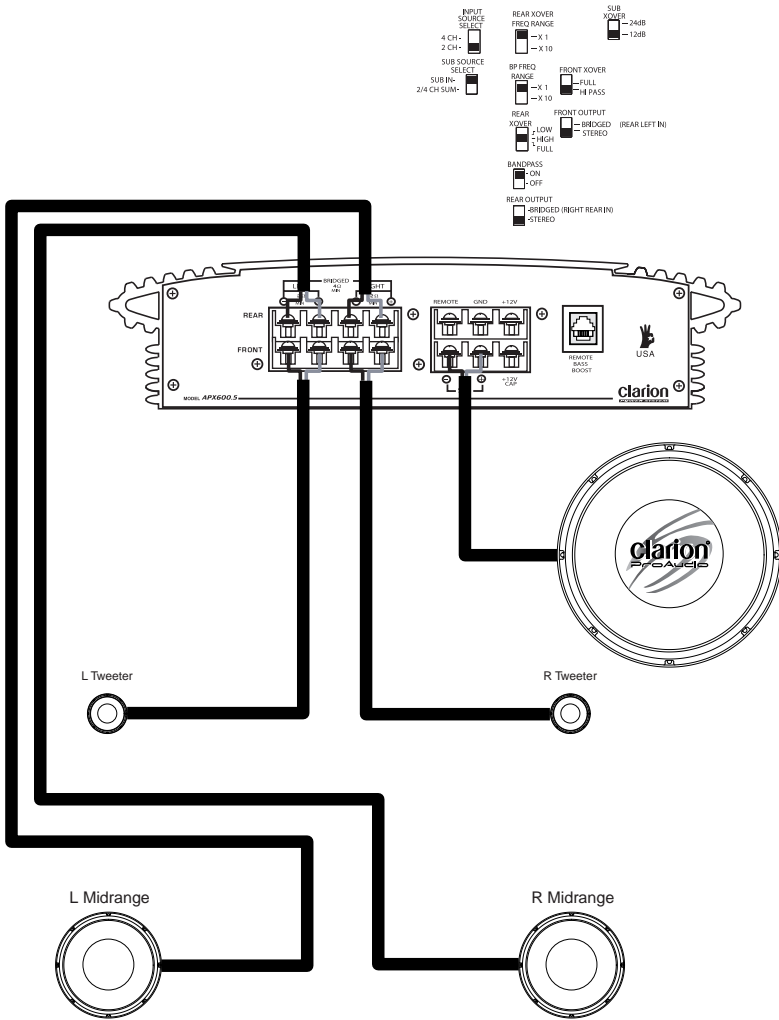

**Figure 7** - The APX600.5 can also be used to drive a pair of tweeters, midrange, and a subwoofer. Note the system configuration settings.

**APPLICATIONS**

## 5-channel System 4-Channels High-Pass Plus Sub

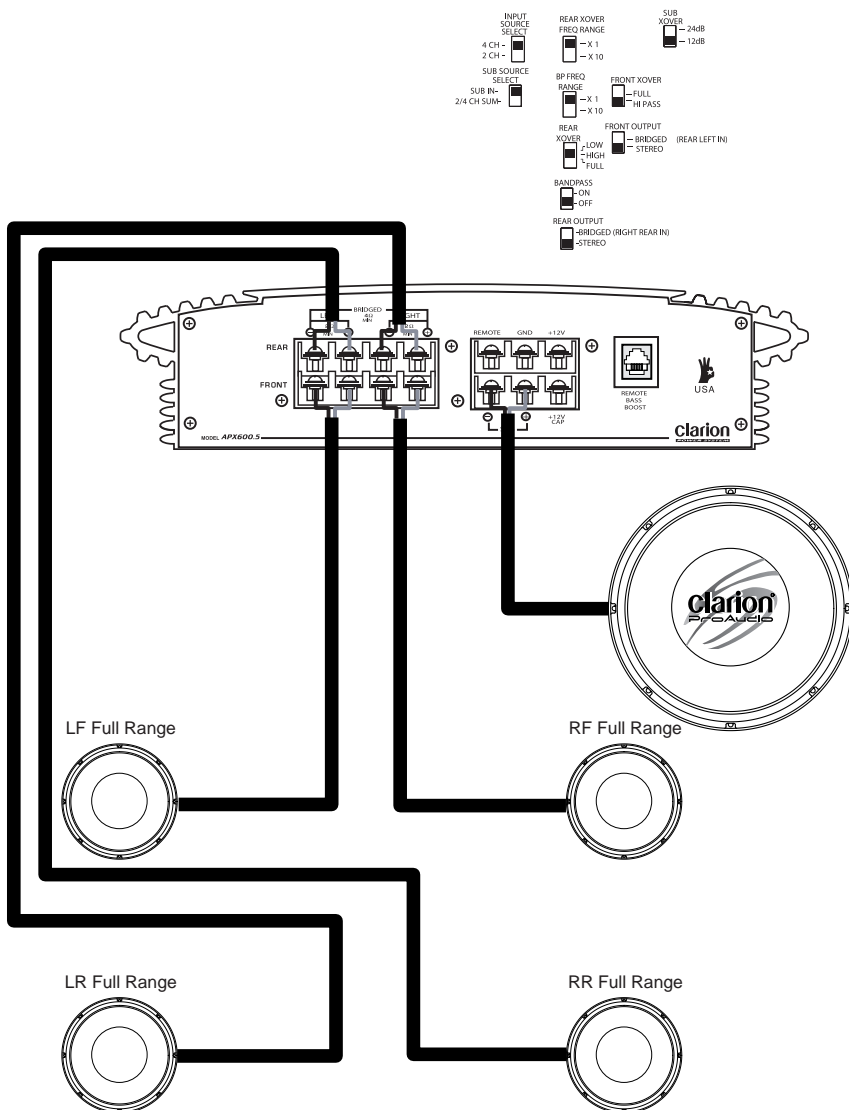

**Figure 8** - In this 5-channel system, the APX600.5 drives two pairs of stereo full range or satellite speakers for the front and rear plus a subwoofer. Note the system configuration settings.

## **INSTALLATION**

This section lists Mounting and Wiring Precautions for installing the Clarion APX600.5. These safeguards provide enough detail to successfully complete an installation. If you do not have the necessary skills, Clarion recommends consulting your authorized Clarion dealer for installation.

### **MOUNTING PRECAUTIONS**

Although the Clarion APX600.5 incorporates heat sinks and protection circuits, mounting the amplifier in a tight space without any air movement can still damage internal circuitry over time. Choose a site that provides adequate ventilation around the amplifier. For easy system set-up, mount the amplifier so the front panel controls will be accessible after installation.

In addition, observe the following precautions:

1. For the most efficient cooling, mount the amplifier so cool air runs along the length of the fins rather than across them. Remember, any moving air will dissipate heat.
2. Mount the amplifier on a rigid surface. Avoid mounting to subwoofer enclosures or areas prone to vibration. Do not install the amplifier on plastic or other combustible materials.
3. Prior to drilling, make sure proposed mounting holes will not cut into the fuel tank, fuel lines, brake lines (under chassis), or electrical wiring.

### **WIRING PRECAUTIONS**

Read all wiring precautions. If you are not sure of the connections, contact your authorized Clarion dealer.

1. Before installation, make sure the source unit Power switch is in the OFF position.
2. Disconnect the negative (-) lead of the battery before making any power connections.
3. When making connections, be sure that each connection is clean and secure. Insulate final connections with electrical tape or shrink tubing. Failure to do so may damage your equipment.
4. A secure clean ground connection is critical to the performance of your Clarion amplifier. Use the shortest ground wire possible and securely connect to the car chassis to minimize resistance and avoid noise problems.
5. Add an external fuse on the amplifier's positive (+) power lead and connect it as close as possible to the vehicle's (+) battery terminal. Use a rating that equals the total current consumption at full output of all amplifiers in the system. Adding an external fuse will protect the electrical system from short circuits that can cause a fire.

# Clarion APX600.5 Power System Amplifier

6. Refer to Figure 9 when making electrical connections. Connect the amplifier's positive (+) lead via a fuse directly to the positive (+) terminal on the battery. Do not connect this wire to the car's fuse panel. Use red-insulated 8-gauge (or larger) wire for the amplifier's positive (+) power lead and the same-gauge black insulated wire for the ground.
7. When replacing the amplifier's fuse, always use one having the same current rating. Substituting a higher-rated fuse or a slow-blow type can result in serious damage to the amplifier.
8. Never ground the speakers to the vehicle chassis or body.
9. Make sure that your vehicle's electrical system (alternator, battery, etc.) is capable of handling the additional load. If you are planning a multi-amplifier system, you may need to add a second battery and possibly upgrade the alternator with a higher-output rated model. Consult your authorized Clarion dealer for recommendations.
10. To avoid noise problems, run the amplifier's positive (+) power lead along one side of the vehicle to the battery. Run the remote turn-on wire and RCA audio cables down the center, and route the speaker wires along the remaining side. If wires must cross, run them perpendicular to each other.
11. When creating passage holes for the power wire, use grommets to eliminate any sharp edges created during drilling. This will protect the wire from being nicked and causing a short circuit.
12. Extra cable can cause signal loss and act as an "antenna" for noise. Use only high-quality RCA cables that are no longer than necessary to make a direct connection with the source unit or equalizer.

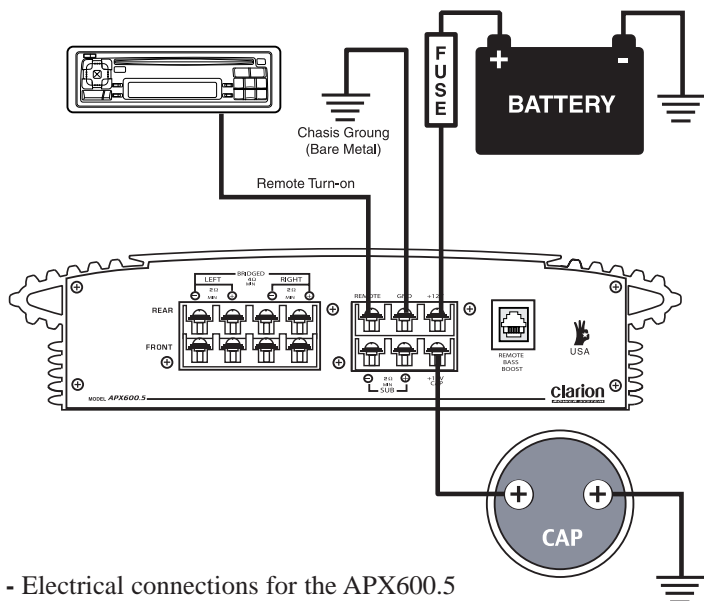

Figure 9 - Electrical connections for the APX600.5

### **SETTING THE GAIN**

After completing the installation, follow these steps to set the Gain Control to tune the amplifier. Then perform the Final System Checks.

1. Turn the Gain Control all the way counter-clockwise.
2. Turn the vehicle's Ignition Switch to the ON position. Then turn the ON/OFF Switch on the source units to the ON position. Set all Tone or Equalization Controls to "flat" positions and turn Loudness off.

Note: If the system uses an equalizer, set its frequency controls to "flat" positions.

3. Play a CD or Tape and set the Volume Control at 75% of full level.
4. Slowly increase the Gain Control. Stop when you hear a slight distortion of audio.

### **SETTING THE CROSSOVER**

The Clarion APX600.5 features fully adjustable front and rear crossovers. To set the crossovers, follow these steps.

1. Using the X-Over Mode Selection Switch, select the desired mode - LP for Low Pass, HP for High Pass and FULL for Full Range.
2. Using the Freq (Hz) Control, select the desired frequency. If the desired frequency exceeds the range of the Freq (Hz) Selection Control, press the Crossover Frequency Multiplier Switch to increase the value by a multiplier of 10. •For example, 55Hz x 10 = 550Hz or 550Hz x 10 = 5.5kHz.
3. Repeat steps 1 and 2 for the front, sub, and rear crossovers.

### **SETTING THE BASS BOOST**

1. Initially set the Subwoofer Bass Boost control to its full left position (i.e. 0dB).
2. Listen to a variety of music styles (e.g. Rock, Rap, etc.) and slowly increase the Bass Boost control until a noticeable increase in low bass response is perceived.
3. Slowly adjust the Bass Boost control (up or down) to realize the best bass response.

**CAUTION:** If you hear a "pop" (due to speaker over-excursion), lower the Bass Boost to prevent speaker damage. If the system sounds muddy and distorted (due to amplifier clipping), lower Bass Boost to avoid shutdown from overheating.

## **FINAL SYSTEM CHECK**

1. Start the engine and turn on the source unit. After a two-second delay, slowly increase the Volume Control and listen to the audio. If you hear any noise, static, distortion or no sound at all, check the connections, and also refer to Troubleshooting. Depending on your system design, the levels may become quite loud even at low Volume Control settings. Until you get an “audio feel” of the system’s power, use care when adjusting controls.
2. Turn the Balance Controls to their extreme positions and listen to the results. The audio output should match the source unit settings. ( Example: source unit setting balance is left, audio from left speaker).
3. Increase the volume and verify that the amplifier reproduces audio (at full frequencies) without distortion. If you hear distortion, check the connections and verify that the Gain Control is set correctly. Another possibility is damaged speakers or under-powered speakers. Once again refer to Troubleshooting for additional help.

## **TROUBLESHOOTING**

### **Problem**

No Audio.

### **Solution**

Low or no remote turn-on voltage. Check remote connections at amplifier and source unit.

Blown amplifier fuse. Replace with new fast-blow fuse (same rating).

Power wires not connected. Check battery and ground wiring at amplifier; also check battery connections.

Speaker leads shorted. Check speaker continuity to ground, it should not show a common ground.

Speakers not connected or are blown. Check speaker connections at amplifier, measure coil impedance.

### **Problem**

Audio cycles on and off.

### **Solution**

Thermal protection circuits are shutting amplifier off. Check location for adequate ventilation; consult an authorized Clarion Audio Dealer.

### **Problem**

Distorted audio.

### **Solution**

Gain is not set properly, or damaged speaker cones. Review Setting Gain; inspect each speaker cone for signs of damage (i.e. frozen cone, burning smell, etc.)

**Problem**

Audio lacks punch.

**Solution**

Speakers wired incorrectly, which causes cancellation of bass frequencies. Check polarity of wires from amplifier to each speaker as defined by the system design.

**Problem**

Amplifier fuse keeps blowing.

**Solution**

Incorrect wiring or short circuit. Review Installation and check all wiring connections.

**Problem**

Whining or ticking noise in the audio with engine on.

**Solution**

Amplifier is picking up alternator noise or radiated noise. Turn down input gain; move audio cables away from power wires. Check power and ground connections on amplifier; install an in-line noise filter on source unit's power wire; check alternator and/or voltage regulator; test for weak battery or add water to battery.

**PRODUCT SPECS**

***APX600.5***

Frequency Response	20Hz ~ 20kHz
S/N Ratio	>107dB
S/N Ratio	>92dB
THD	.05% all channels driven
Input Sensitivity Low Level	250mV ~ 2.5V
Input Sensitivity Speaker Level	500mV ~ 5V
Max. Power Output	75w x 4 & 190W x1 @ <.07% THD
Cont. Power Output	45w x 4 & 120W x1 @ <.05% THD
2-Ohm Stereo Output	75w x 4 & 180W x1
Dimensions	2 1/8" H x 8 1/4" W x 15.75" L
Current Consumption @ Max Power Output	80A @ 600w
Input Impedance	33K ohms
Crossover (Butterworth)	12db Stereo 50Hz - 5.5KHz
Sub	12 / 24db 50Hz - 550Hz
Bass Boost	0-15db @ 45Hz
Damping Factor	>170 @ 1KHz
Sub	>500 @ 1KHz



661 W. Redondo Beach Blvd.  
Gardena, CA 90247  
1-800-GO-CLARION  
[www.clarion-usa.com](http://www.clarion-usa.com)



## Free Manuals Download Website

<http://myh66.com>

<http://usermanuals.us>

<http://www.somanuals.com>

<http://www.4manuals.cc>

<http://www.manual-lib.com>

<http://www.404manual.com>

<http://www.luxmanual.com>

<http://aubethermostatmanual.com>

Golf course search by state

<http://golfingnear.com>

Email search by domain

<http://emailbydomain.com>

Auto manuals search

<http://auto.somanuals.com>

TV manuals search

<http://tv.somanuals.com>