



Featuring the
"Advanced Closed System +3"

ELECTRIC HEATED – with Steam Generator

Cooking Modes:

- Hot Air
- Retherm
- "Delta T" slow cooking
- Steam
- "Cook & Hold"
- "Crisp & Tasty"
- Combi

Cleveland Standard Features:

- "Advanced closed system" with "Crisp & Tasty" de-moisturizing feature
- Efficient heating system for hot air and steam generator saves energy and provides fast heat up times
- Fully insulated steam generator and cooking compartment for maximum energy savings
- Polished cooking compartment with coved corners for easy cleaning
- Five (5) 26" x 20" wire shelves
- Hinged fan guard and hinged removable pan racks
- Two (2) speed auto reversing convection fan for even heat distribution
- Space saving, easy to close "Disappearing Door"
- Door latch with safety vent position and wear-free door switch
- Vented, double glass door with integrated door stop and self draining condensate drip pan
- Easy to change, press-fit door seal
- Oven light with shock resistant safety glass
- Multipoint core temperature probe
- Easy to use electronic controls for all operational functions
- Self diagnostic system with full text message display
- Easy to understand menu icons with bright graphics display
- User friendly selector dial
- Exclusive "Smart Key" for selecting option settings
- Digital controls for temperature, time and core probe settings
- Eight (8) "Press & Go" one step, recipe start buttons
- Cook book library for up to 250 stored recipe programs, each recipe capable of 20 steps
- RS 232 connection for controlling one unit with a PC (personal computer)
- Memory module automatically saves unit settings and recipes
- Manual program override feature for operational settings
- Smooth action hand shower for compartment cleaning

Electric Steam Generator

- Built-in automatic rinse system
- Automatic fill and water level control
- Automatic generator drain

MODEL: OEB-10.20

CAPACITY: Eleven (11) - 18" by 26" by 1" full size sheet pans* or
 Twenty-two (22) - 13" by 18" by 1" half size sheet pans* or
 Twenty (20) - 12" x by 20" by 2 1/2" steam table pans
 *On wire racks. Additional wire racks required for maximum capacity.



Short Form Specifications

Shall be Cleveland Model: OEB-10.20 Combination Convection Oven / Steamer with simple to operate electronic programmable controls for Hot Air, Convection Steam, and Combination cooking modes, "Cook & Hold" and "Delta T" slow-cooking capabilities, "Advanced Closed System" with "Crisp & Tasty" de-moisturizing feature. Multiple cooking stage programs, stored recipe library, multipoint core temperature probe, "Press & Go", one-step recipe start buttons, "Smart Key" for selecting option settings, Two (2) speed auto reversing convection fan. Electric steam generator with automatic drain. "Disappearing Door". Capacity for ten (10) 18" x 26" full size sheet pans, or twenty (20) 12" x 20" x 2 1/2" pans.

Options and Accessories

- ConvoClean automatic compartment washing system
- PC-HACCP software for establishing "HACCP controls" and automatic documentation of the cooking process
- Equipment stand(s)
- Equipment stand(s) with Casters
- Stacking kit for mounting one (1) OEB-6.20 model on top of one (1) OEB-10.20
- Universal pan-rack system to hold full size sheet pans without the use of wire shelves
- Lockable cover over operating controls for prison installations
- USB or RS 485 connection for networking and controlling up to 32 units with a personal computer
- Plate rack for banquet operations
- Plate rack cart
- Thermal cover for plate or pan rack
- ConvoClean compartment cleaning solution
- ConvoCare concentrate for compartment rinse cycle
- "Dissolve" generator descaling solution
- Chicken Grill Rack
- 12" x 20" Wire Baskets for frying products
- Additional 26" x 20" Wire Shelves
- Special Baking Rack System
- 480 volt option
- Kleensteam II Water Filters

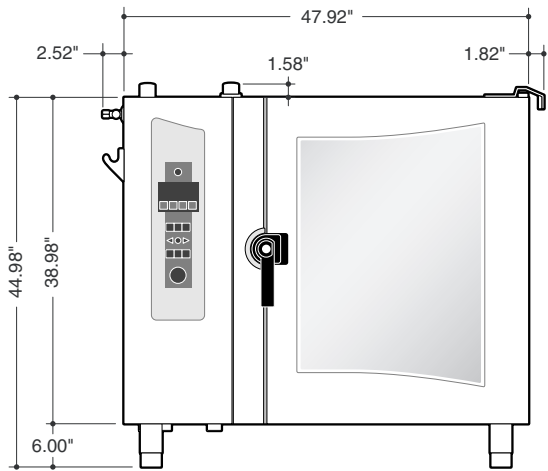

FRONT VIEW

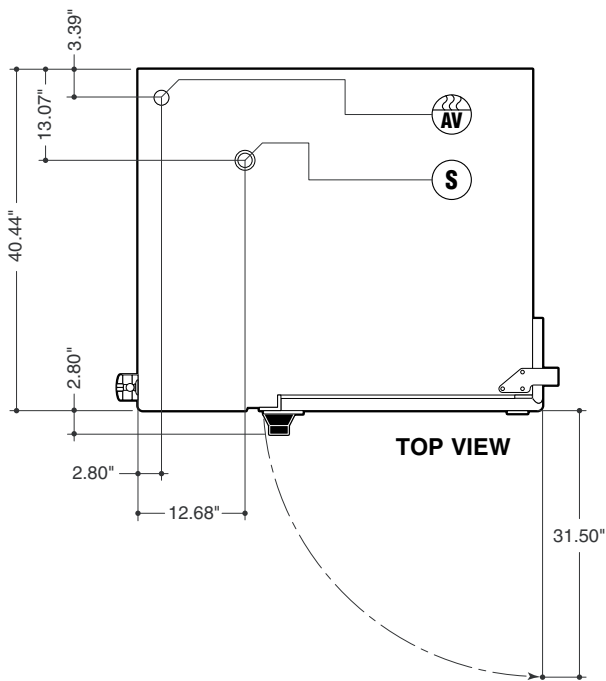

TOP VIEW

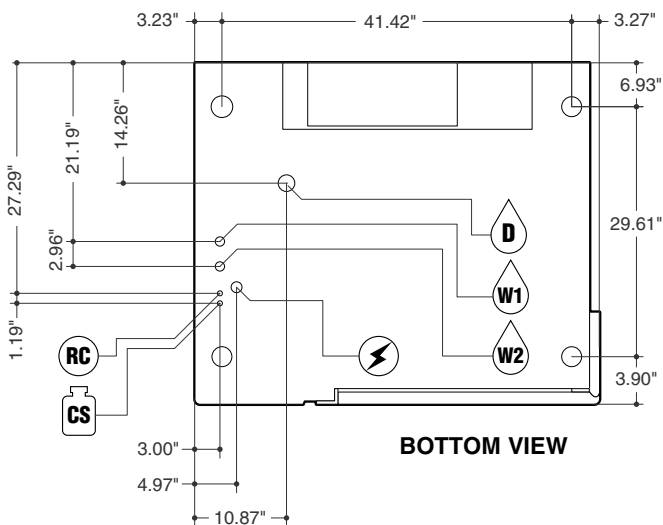

BOTTOM VIEW

The "Advanced Closed System" offers the following advantages:

- Saves energy
- Automatic moisture level adjustment
- Low heat and steam emission to the kitchen
- Automatically regulated steam injection
- Enables immediate change into the steam mode
- "Crisp & Tasty" demisterizing function

Model: OEB-10.20

Pan Capacity [Unit has 11 slide rails at 2.64" (67mm) apart]:

11 (20" x 26") full size wire racks	11 (18" x 26") full size sheet pans - on wire racks
22 (13" x 18") half size sheet pans - on wire racks	20 (12" x 20" x 2 1/2") steam table pans
22 (12" x 20" x 1") steam table pans	20 (12" x 20") frying baskets - (no wire racks needed)

For Banquet Operations: Optional Plate Rack holds 63 plates

Unit Dimensions: Width - 52.26", Depth - 43.24", Height - 45.68"

Shipping Dimensions: Width - 58", Depth - 49", Height - 54"
(including packaging)

Shipping Weight: 540 Lbs

Required Clearances: Rear - 2", Left Side - 4", Right Side - 2 1/2"

- Allow for sufficient distance if a "high heat source" (i.e. Broiler) is located next to the unit.
- Allow for sufficient clearance on left side for service access (contact the factory service department for recommendations).
- Installation must comply with all local fire and health codes.

Agency Approvals: UL, UL - Sanitation (NSF Standards)



Electrical Requirements:	208/3/60	240/3/60	440/3/60	480/3/60
Total Connected Load:	26.3 KW	34.9 KW	29.4 KW	34.9 KW
Hot Air:	25.8 KW	34.3 KW	28.8 KW	34.3 KW
Steam Generator:	20.5 KW	27.3 KW	22.9 KW	27.3 KW
Amps per Phase:	77.8	88.8	41.4	44.9

Do not connect to a G.F.I. outlet

Water Connections: Cold Water (drinking water quality)
Flow Pressure: 30 - 60 PSI
Water Inlets: 3/4" GHT-F (Female Garden Hose Connection)



Treated Water for Steam Generator



Untreated Water for Condenser and Hand Shower



Drain Connection: 2" Tube

Venting: Exhaust Hood required



Air Vent



*Connection for Cleaning Solution



*Connection for Rinse Cycle



Low Pressure Safety Valve

*Available as an option

NOTES:

Cleveland Range reserves right of design improvement or modification, as warranted.
Many regional, state and local codes exist and it is the responsibility of the owner and installer to comply with the codes.
Cleveland Range equipment is built to comply with applicable standards for manufacturers.

Free Manuals Download Website

<http://myh66.com>

<http://usermanuals.us>

<http://www.somanuals.com>

<http://www.4manuals.cc>

<http://www.manual-lib.com>

<http://www.404manual.com>

<http://www.luxmanual.com>

<http://aubethermostatmanual.com>

Golf course search by state

<http://golfingnear.com>

Email search by domain

<http://emailbydomain.com>

Auto manuals search

<http://auto.somanuals.com>

TV manuals search

<http://tv.somanuals.com>