

Notebook Computer

D400S/D410S

Service Manual

Notice

The company reserves the right to revise this publication or to change its contents without notice. Information contained herein is for reference only and does not constitute a commitment on the part of the manufacturer or any subsequent vendor. They assume no responsibility or liability for any errors or inaccuracies that may appear in this publication nor are they in anyway responsible for any loss or damage resulting from the use (or misuse) of this publication.

This publication and any accompanying software may not, in whole or in part, be reproduced, translated, transmitted or reduced to any machine readable form without prior consent from the vendor, manufacturer or creators of this publication, except for copies kept by the user for backup purposes.

Brand and product names mentioned in this publication may or may not be copyrights and/or registered trademarks of their respective companies. They are mentioned for identification purposes only and are not intended as an endorsement of that product or its manufacturer.

Version 1.0
March 2003

Trademarks

Intel[®] and **Pentium**[®] are registered trademarks of Intel Corporation.

Windows[®] is a registered trademark of Microsoft Corporation.

Other brand and product names are trademarks and./or registered trademarks of their respective companies.

About this Manual

This manual is intended for service personnel who have completed sufficient training to undertake the maintenance and inspection of personal computers.

It is organized to allow you to look up basic information for servicing and/or upgrading components of the *D400S/D410S* series notebook PC.

The following information is included:

Chapter 1, Introduction, provides general information about the location of system elements and their specifications.

Chapter 2, Disassembly, provides step-by-step instructions for disassembling parts and subsystems and how to upgrade elements of the system.

Appendix A, Part Lists

Appendix B, Schematic Diagrams

Appendix C, Upgrading Flash ROM BIOS

Related Documents

You may also need to consult the following manual for additional information:

User's Manual on CD

This describes the notebook PC's features and the procedures for operating the computer and its ROM-based setup program. It also describes the installation and operation of the utility programs provided with the notebook PC.

Contents

Introduction	1-1	Mainboard Overview - Bottom (Key Parts)	1-12
Overview	1-1	Mainboard Overview - Top (Connectors)	1-13
System Specifications	1-2	Mainboard Overview - Bottom (Connectors)	1-14
Processor	1-2	Disassembly	2-1
Core Logic	1-2	Overview	2-1
Structure	1-2	Maintenance Tools	2-2
Security	1-2	Connections	2-2
Memory	1-2	Maintenance Precautions	2-3
BIOS	1-2	Cleaning	2-3
LCD Options	1-2	Disassembly Steps	2-4
Display	1-3	Removing the Battery	2-8
Storage Devices	1-3	Removing the Hard Disk Drive	2-9
Audio	1-3	Hard Disk Upgrade Process	2-9
Keyboard	1-4	Removing the System Memory (RAM)	2-10
Interface	1-4	Memory Upgrade Process	2-10
PC Card	1-4	Removing the CD Device	2-12
Communication	1-4	Removing the Bluetooth Module	2-14
Power Management	1-5	Removing the Wireless LAN Module	2-15
Power	1-5	Removing the Processor	2-16
Indicators	1-5	Removing the Keyboard	2-18
Environmental Spec	1-5	Removing the Keyboard Shielding Plate	2-19
Physical Dimensions	1-5	Removing the LCD and Top Case	2-20
Weight	1-5	Removing the TouchPad and Click Board	2-22
Optional	1-6	Removing the Switch Board	2-23
Design Differences	1-6	Removing the Modem	2-24
External Locator - Top View	1-7	Removing the Speakers	2-25
External Locator - Front & Left Side Views	1-8	Removing the Mainboard	2-26
External Locator - Right Side & Rear Views	1-9	Removing the Fan Unit	2-27
External Locator - Bottom View	1-10	Removing the Floppy Disk Drive Assembly	2-28
Mainboard Overview - Top (Key Parts)	1-11	Removing the PC Card Assembly	2-29

Preface

Removing the LCD Front Panel Module	2-30
Removing the Inverter	2-31
Removing the PC Video Camera Module	2-32
Removing the LCD Module	2-33

Part ListsA-1

Part List Illustration Location	A-2
Top (400S)	A-3
Bottom (400S)	A-4
LCD 14" (400S)	A-5
LCD 15" (400S)	A-6
CD-ROM Drive (400S)	A-7
CD-RW Drive (400S)	A-8
Combo Drive (400S)	A-9
DVD-ROM Drive (400S)	A-10
Floppy Disk Drive (400S)	A-11
Hard Disk Drive (400S)	A-12
Top (410S)	A-13
Bottom (410S)	A-14
LCD 14" (410S)	A-15
LCD 15" (410S)	A-16
CD-ROM Drive (410S)	A-17
CD-RW Drive (410S)	A-18
Combo Drive (410S)	A-19
DVD-ROM Drive (410S)	A-20
Floppy Disk Drive (410S)	A-21
Hard Disk Drive (410S)	A-22

Schematic Diagrams.....B-1

System Block Diagram	B-2
Socket 478 1 of 2	B-3
Socket 478 & ITP 2 of 2	B-4
Clock Generator	B-5

M650 (Host/AGP) 1 of 4	B-6
M650 (Memory for DDR) 2 of 4	B-7
M650 (& CRT Out) 3 of 4	B-8
M650 (Power) 4 of 4	B-9
DDR Memory DIMM	B-10
DDR SSTL-2 Termination	B-11
LVDS Interface (SiS302LV)	B-12
Panel Con & LED Indicator	B-13
962 (PCI/IDE/HyperZip) 1 of 4	B-14
962 (Misc Signals) 2 of 4	B-15
962 (USB I/F) 3 of 4	B-16
962 (Power & RTC) 4 of 4	B-17
HDD/Combo Connector	B-18
USB Port	B-19
PCMCIA TI1410	B-20
PCMCIA Power	B-21
1394 PHY TSB41LV01	B-22
LPC SI/O	B-23
LPT/COM Port	B-24
LPC H8	B-25
LAN RTL8100BL	B-26
Audio Codec ALC201A	B-27
Audio Out & Off Board Connectors	B-28
System Power Control	B-29
Fan Control and SpeedStep	B-30
VCORE	B-31
DDR Power	B-32
System	B-33
Charger	B-34
SW Board and HotKey	B-35
TouchPad and Switch Board	B-36

Updating the FLASH ROM BIOS..... C-1

1: Introduction

Overview

This manual covers the information you need to service or upgrade the **D400S/D410S** series notebook computer. Information about operating the computer (e.g. getting started, and the *Setup* utility) is in the *User's Manual*. Information about drivers (e.g. VGA & audio) is also found in *User's Manual*. That manual is shipped with the computer.

Operating systems (e.g. *DOS*, *Windows 9x*, *Windows NT 4.0*, *Windows 2000*, *Windows XP*, *OS/2 Warp*, *UNIX*, etc.) have their own manuals as do application software (e.g. word processing and database programs). If you have questions about those programs, you should consult those manuals.

The **D400S/D410S** series notebook is designed to be upgradeable. See "**Disassembly**" on page 2 - 1 for a detailed description of the upgrade procedures for each specific component. Please note the warning and safety information indicated by the "⚠" symbol.

The balance of this chapter reviews the computer's technical specifications and features.

System Specifications

Processor

- Intel Pentium 4 Processor - (478-pin) FC-PGA2 package
 - (μ 0.13) 0.13 Micron Process Technology, 512KB L2 Cache & 400MHz FSB - 2.0/ 2.2/ 2.4/ 2.5 /2.6 GHz
 - (μ 0.13) 0.13 Micron Process Technology, 512KB L2 Cache & 533MHz FSB - 2.26/ 2.4/ 2.53/ 2.66/ 2.66/ 2.8 GHz

Core Logic

- SIS M650 + 962

Structure

- PC99 compliant

Security

- Security (Kensington® Type) Lock
- BIOS Password

Memory

- Two 200-pin DDR SODIMM sockets, supporting DDR SDRAM SODIMM (2.5V) - DDR 200/ DDR 266/ DDR 333 compliant
- Memory expandable up to 1024MB (128/256/512MB SODIMM Modules)

BIOS

- One 512KB Flash ROM
- Phoenix BIOS

LCD Options

- 14.1" XGA TFT (1024*768)
- 15.0" XGA TFT (1024*768)
- 15.0" SXGA+ TFT(1400*1050)



Video Memory

The system allocates or "shares" a portion of system memory for video use. "Shared" memory is user-configurable via the SCU. The default setting is set to 32MB.

Display

- High Performance 256-bit 3D engine
- Advanced HW accelerator for DVD playback
- Fully Direct X 8.0 compliant graphics engine
- Dual-View display monitor
- CRT Resolution up to 2048 * 1536

Storage Devices

- 3.5" 3-mode **Floppy Disk Drive**
- Easy changeable 2.5" 9.5 mm (h) Hard Disk Drive
Supporting Master mode IDE
Supports PIO mode 4
ATA-33/66/100/133
Ultra DMA
- 12.7mm(h) **Device Bay** for **ONE** of the following drive configuration options:
 - 24* CD-ROM
 - 8* DVD-ROM
 - CD-RW (16* CD-R/ 10* CD-RW/ 24* CD-ROM)
 - Combo (8* DVD-ROM/ 8* CD-R/ 8* CD-RW/ 24* CD-ROM)
 - Combo (8* DVD-ROM/ 24* CD-R/ 10* CD-RW/ 24* CD-ROM)

Audio

- AC'97 2.1 compliant interface
- 3D stereo enhanced sound system
- Compatible with Sound-Blaster PRO™
- S/PDIF Digital output (5.1 CH) for DVD content and stereo audio
- Microphone-in jack
- Headphone-out jack
- Built-in microphone
- 2 built-in speakers (1 watt 35 * 16 mm)

Introduction

Keyboard

- “Win Key” keyboard

Interface

- Built-in TouchPad (scrolling key functionality integrated)
- Three USB 2.0 ports
- One IEEE 1394 port
- One S-Video jack for TV output
- One serial port
- One parallel port (LPT1), supporting ECP / EPP
- Infrared transceiver IrDA 1.1 FIR/SIR/ASKIR
- One external CRT monitor port
- One external keyboard/mouse (through Y cable) PS/2 port
- One speaker-out/headphone-out jack
- One microphone-in jack
- One RJ-11 jack for modem
- One RJ-45 jack for 100M/10M LAN
- One S/PDIF out port
- One DC-in jack

PC Card

- One type II PCMCIA 3.3V/5V socket supporting CardBus

Communication

- Wireless Infrared transfer IrDA 1.1 compliant, 1cm - 1M operating distance, 115.2K bps SIR/ 4Mbps FIR
- 10/100Mb Ethernet LAN built-in
- 56K MDC modem V.90 & V.92 compliant
- 802.11b wireless LAN module (available as a factory option)
- Bluetooth module (available as a factory option)
- Built-in PC camera module (available as a factory option)

Power Management

- Supports ACPI v1.0b
- Supports Hibernate mode
- Supports Standby mode
- Supports battery low sleep
- Supports resume from modem ring

Power

- Full range AC adapter
- AC-Input 100~240V, 50~60Hz
- DC Output 20V, 3.25A (**90w**)
- Supports one removable Smart Li-Ion battery 2200mAh/8 cell

Indicators

- LED indicators (HDD, Power On/ AC-In/ Suspend, Battery Charging/Battery Full, Num Lock, Caps Lock, Scroll Lock)

Environmental Spec

- Temperature
 - Operating: 5°C ~ 35°C
 - Non-Operating: -20°C ~ 60°C
- Relative Humidity
 - Operating: 20% ~ 80%
 - Non-Operating: 10% ~ 90%

Physical Dimensions

- 329 (w) x 275 (d) x 36.5 (h) mm

Weight

- 3.0 kg w/o battery

Introduction

Optional

- DVD-ROM Drive
- CD-RW Drive
- Combination Drive
- Software DVD player
- Wireless LAN module
- Bluetooth module
- Video Camera

Design Differences

This manual refers to the two notebook designs pictured below. The designs vary slightly in external design. Photographs used throughout this manual are of Design I.

Figure 1
Design Differences



Design I



Design II

External Locator - Top View

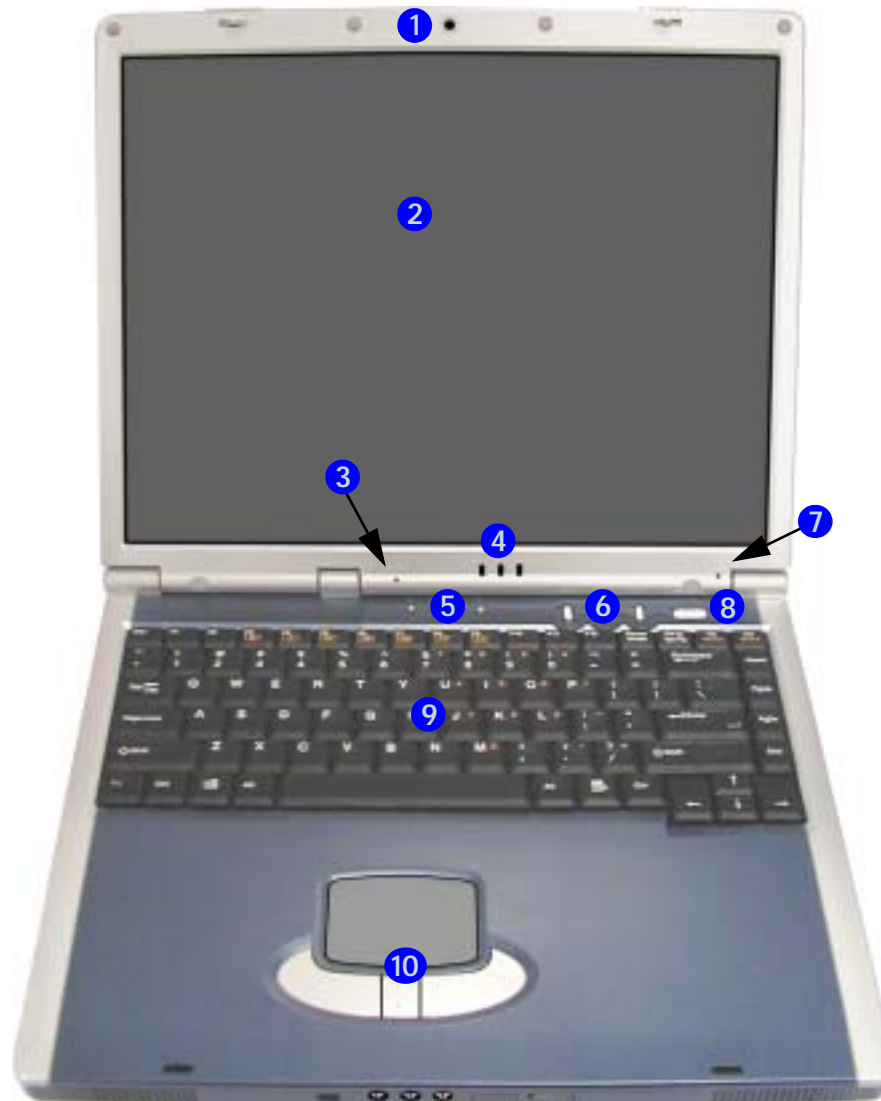

Figure 2
Top View

1. Optional Built-in USB Camera
2. LCD
3. Built-In Microphone
4. LED Power & Communication Indicators
5. LED Status Indicators
6. Hot-Key buttons
7. Close Cover Switch
8. Power Button
9. Keyboard
10. TouchPad and Buttons

Introduction

Figure 3
Front View

1. LCD Latches
2. IEEE 1394 Port
3. S/PDIF Out Port
4. Microphone-In Jack
5. Headphone-Out Jack
6. Infrared Transceiver
7. Wireless LAN On/Off Switch
8. Built-In Speakers

External Locator - Front & Left Side Views

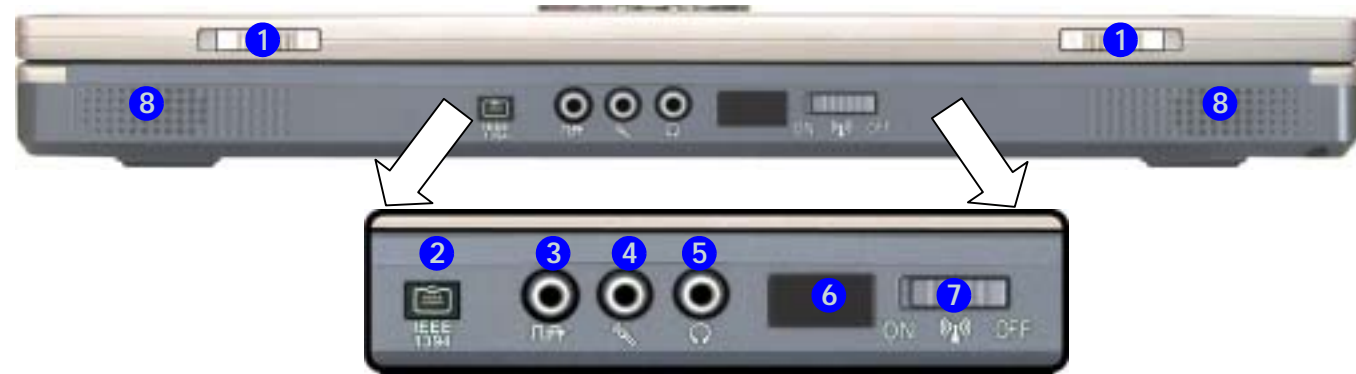
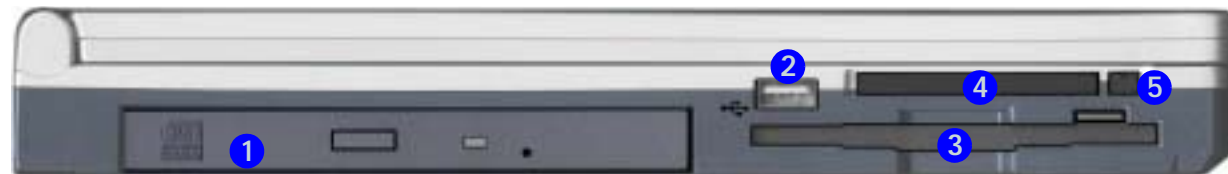

Figure 4
Left Side View

1. CD Device Bay
2. USB 2.0 Port
3. Floppy Disk Drive
4. PC Card Slot
5. PC Card Slot Eject Buttons



1 - 8 External Locator - Front & Left Side Views

External Locator - Right Side & Rear Views

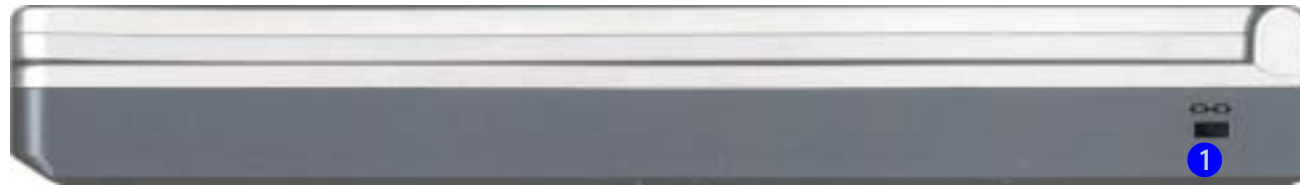

Figure 5
Right Side View

1. Security Lock Slot



Figure 6
Rear View

1. Vent
2. DC-In Jack
3. 2 * USB Ports
4. External Monitor (CRT) Port
5. Parallel Port
6. Serial Port
7. S-Video-Out Port
8. PS/2 Type Port
9. RJ-11 Phone Jack
10. RJ-45 LAN Jack



External Locator - Bottom View

Figure 7
Bottom View

1. Vent/Fan Outlets
2. Battery Cover
3. Hard Disk Cover
4. Bluetooth Module Cover
5. CPU Heatsink Cover

Note: The RAM and optional Wireless LAN module are located under the CPU Heatsink Cover



Mainboard Overview - Top (Key Parts)

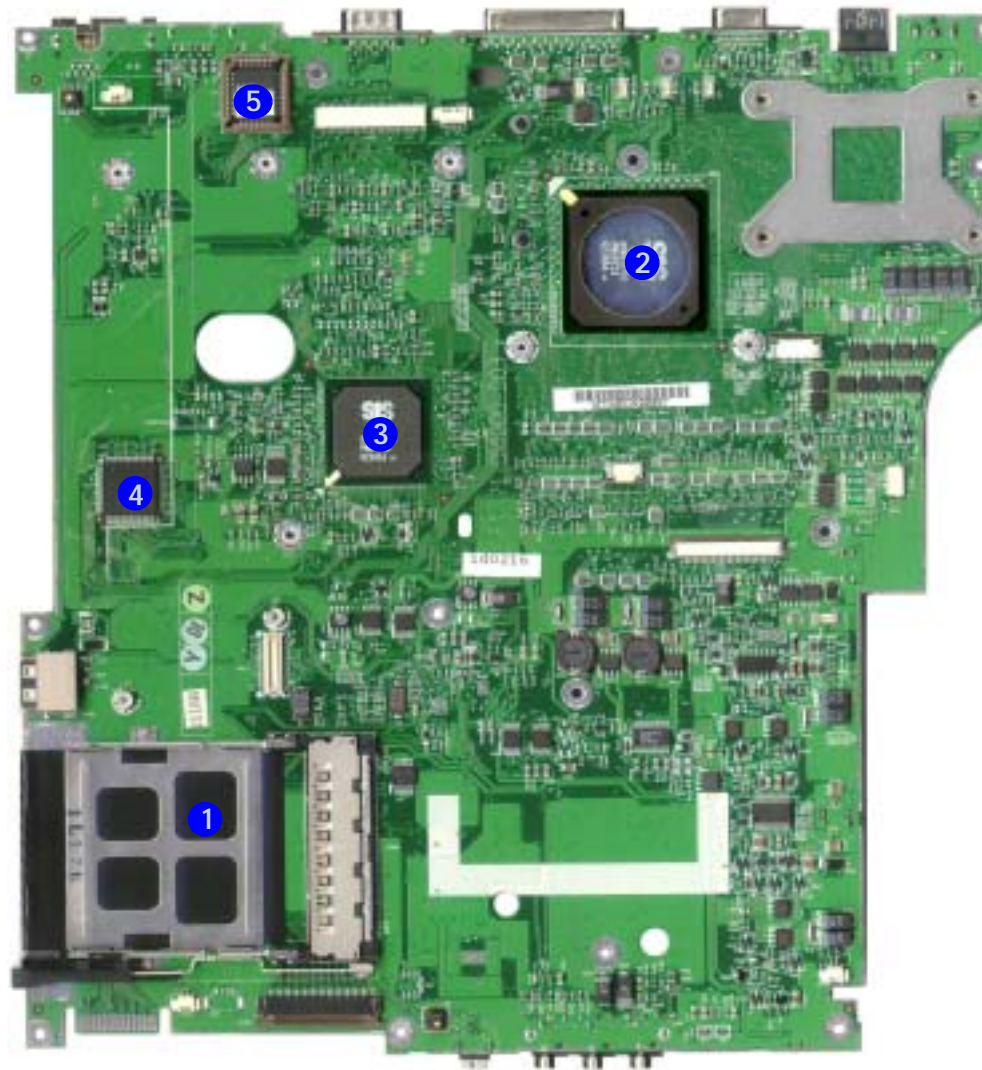

Figure 8
**Mainboard Top
Key Parts**

1. PC Card Assembly
2. Northbridge - SiS M650
3. Southbridge - SiS 962
4. LPC Super I/O NS PC87393
5. Flash ROM BIOS

Introduction

Figure 9
**Mainboard Bottom
Key Parts**

1. CPU Socket (no CPU installed)
2. Memory Sockets (no memory installed)
3. SiS 302LV TV-Out Controller
4. LAN Controller RTL8100BL
5. CardBus ENE 1410
6. ALC202 - Audio Codec
7. 1394 PHY TSB41LV01
8. Clock Generator
9. Keyboard Controller - KBC H8 H8S-2149 HM

Mainboard Overview - Bottom (Key Parts)

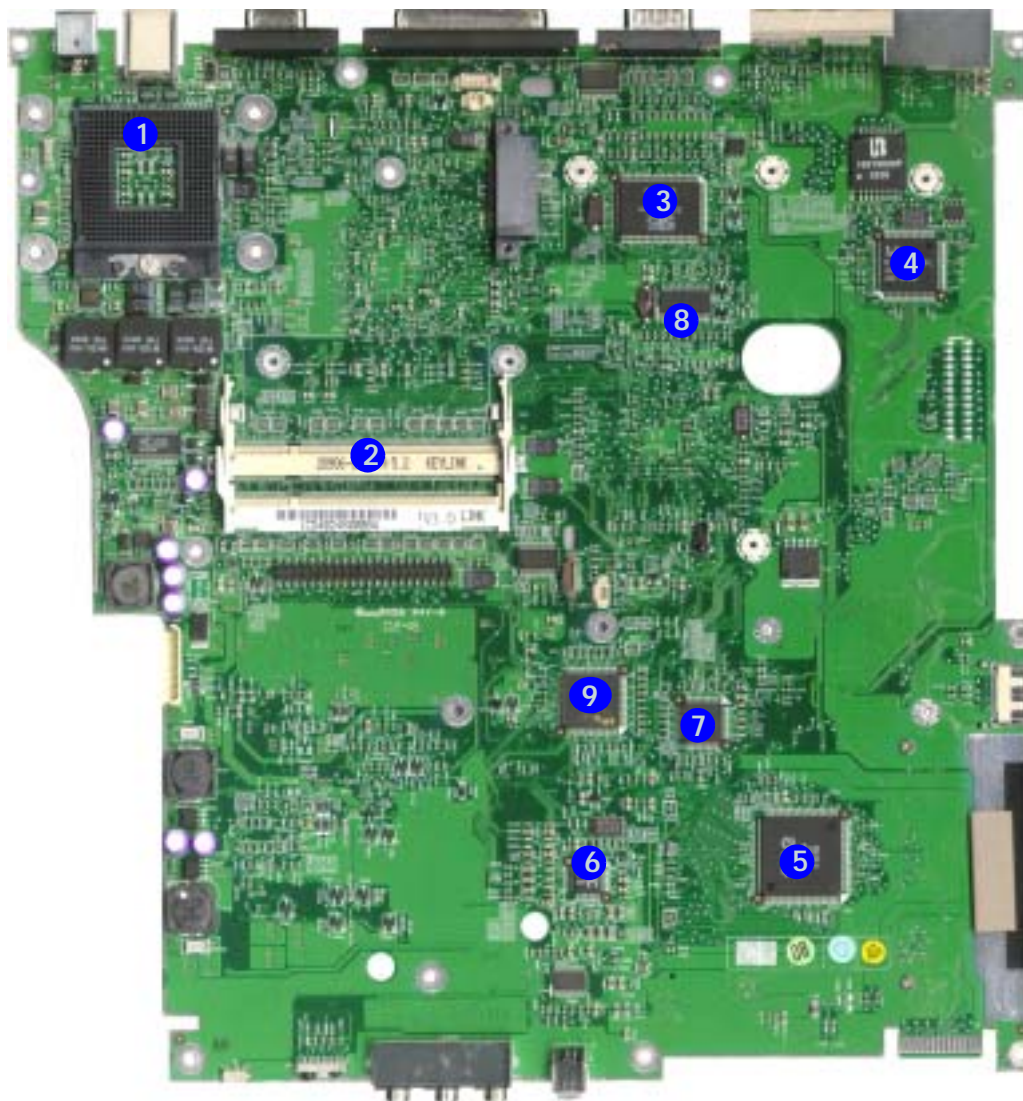

1 - 12 Mainboard Overview - Bottom (Key Parts)

Mainboard Overview - Top (Connectors)

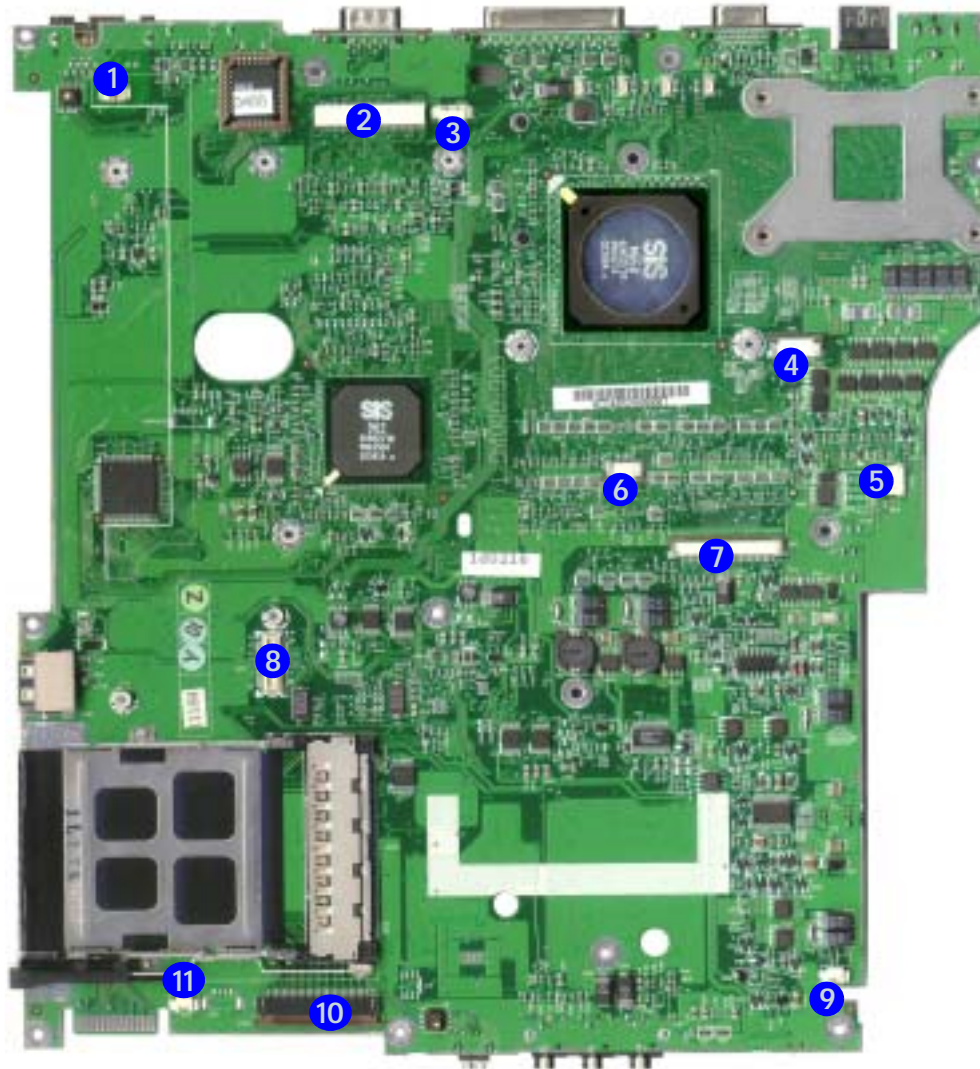

Figure 10
**Mainboard Top
Connectors**

1. Modem Cable Connector (CN1)
2. LCD and Inverter Connector (JLCD1)
3. Video Camera Module Connector (JCCD1)
4. Switch Board Connector (JSW1)
5. Fan Connector (JFAN1)
6. TouchPad Connector (JTP1)
7. Keyboard Connector (JKB1)
8. Modem Connector (JMDC1)
9. Speaker Connector (JSPK1)
10. Floppy Disk Controller (JFDD1)
11. Speaker Connector (JSPK2)

Introduction

Figure 11
**Mainboard Bottom
Connectors**

1. Wireless LAN Connector (JWL1)
2. Fan Connector (JFAN2)
3. CD Connector (JCDROM1)
4. Hard Disk Connector (JHDD1)
5. Bluetooth Connector (JBT1)
6. Battery Connector (JBAT1)
7. Battery Connector (CN5)

Mainboard Overview - Bottom (Connectors)

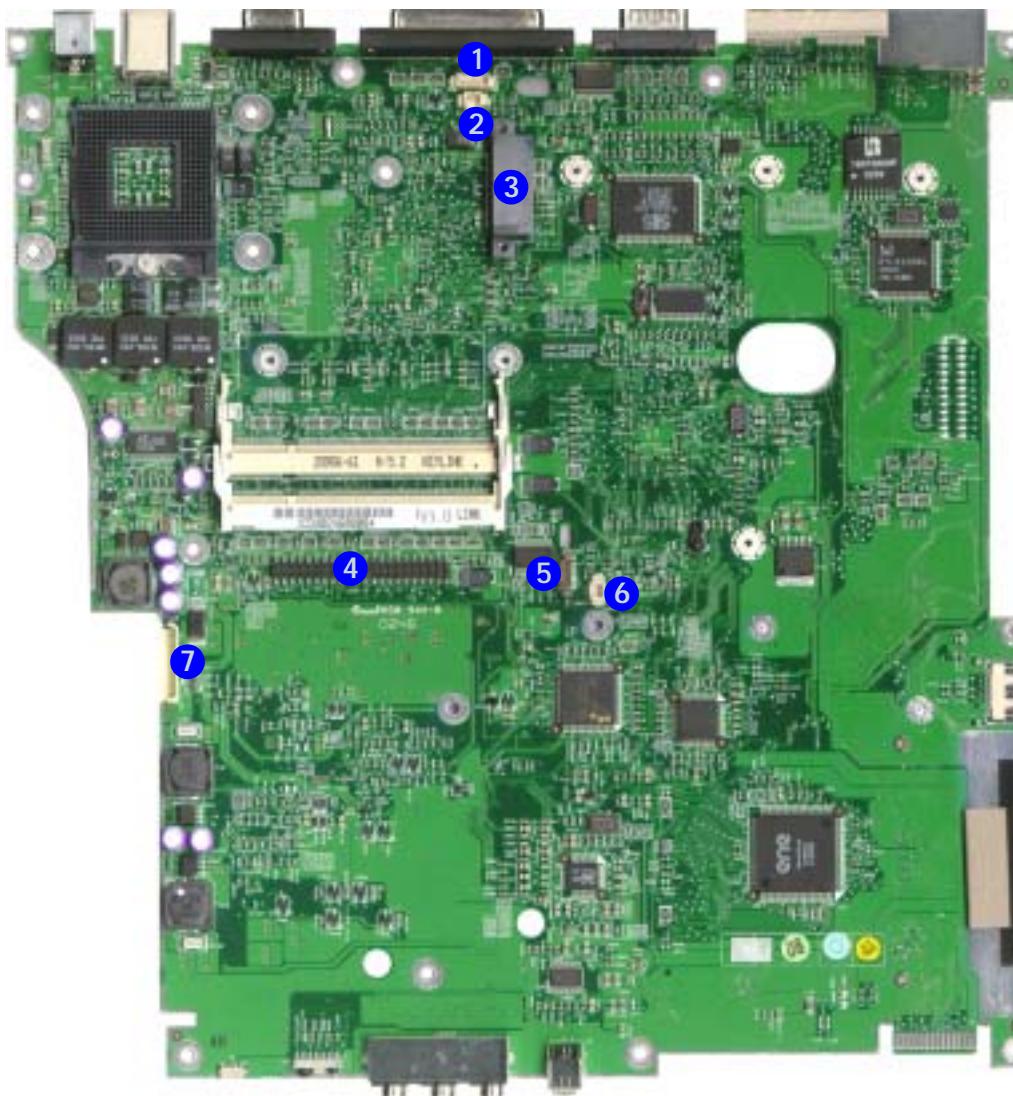

2: Disassembly



Overview

This chapter provides step-by-step instructions for disassembling the *D400S/D410S* series notebook's parts and sub-systems. When it comes to reassembly, reverse the procedures (unless otherwise indicated).

We suggest you completely review any procedure before you take the computer apart.

Procedures such as upgrading/replacing the RAM, CD device and hard disk are included in the User's Manual but are repeated here for your convenience.

To make the disassembly process easier each section may have a box in the page margin. Information contained under the figure # will give a synopsis of the sequence of procedures involved in the disassembly procedure. A box with a  lists the relevant parts you will have after the disassembly process is complete. **Note:** The parts listed will be for the disassembly procedure listed ONLY, and not any previous disassembly step(s) required. Refer to the part list for the previous disassembly procedure. The amount of screws you should be left with will be listed here also.

A box with a  will provide any possible helpful information. A box with a  contains warnings.

An example of these types of boxes are shown in the sidebar.

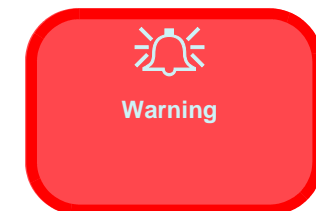
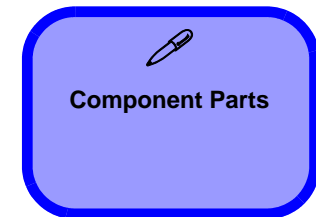

Disassembly

NOTE: All disassembly procedures assume that the system is turned **OFF**, and disconnected from any power supply (the battery is removed too).

Maintenance Tools

The following tools are recommended when working on the notebook PC:

- M3 Philips-head screwdriver
- M2.5 Philips-head screwdriver (magnetized)
- M2 Philips-head screwdriver
- Small flat-head screwdriver
- Pair of needle-nose pliers
- Anti-static wrist-strap

Connections

Connections within the computer are one of four types:

Locking collar sockets for ribbon connectors	To release these connectors, use a small flat-head screwdriver to gently pry the locking collar away from its base. When replacing the connection, make sure the connector is oriented in the same way. The pin1 side is usually not indicated.
Pressure sockets for multi-wire connectors	To release this connector type, grasp it at its head and gently rock it from side to side as you pull it out. Do not pull on the wires themselves. When replacing the connection, do not try to force it. The socket only fits one way.
Pressure sockets for ribbon connectors	To release these connectors, use a small pair of needle-nose pliers to gently lift the connector away from its socket. When replacing the connection, make sure the connector is oriented in the same way. The pin1 side is usually not indicated.
Board-to-board or multi-pin sockets	To separate the boards, gently rock them from side to side as you pull them apart. If the connection is very tight, use a small flat-head screwdriver - use just enough force to start.

Maintenance Precautions

The following precautions are a reminder. To avoid personal injury or damage to the computer while performing a removal and/or replacement job, take the following precautions:

1. **Don't drop it.** Perform your repairs and/or upgrades on a stable surface. If the computer falls, the case and other components could be damaged.
2. **Don't overheat it.** Note the proximity of any heating elements. Keep the computer out of direct sunlight.
3. **Avoid interference.** Note the proximity of any high capacity transformers, electric motors, and other strong magnetic fields. These can hinder proper performance and damage components and/or data. You should also monitor the position of magnetized tools (i.e. screwdrivers).
4. **Keep it dry.** This is an electrical appliance. If water or any other liquid gets into it, the computer could be badly damaged.
5. **Be careful with power.** Avoid accidental shocks, discharges or explosions.
 - Before removing or servicing any part from the computer, turn the computer off and detach any power supplies.
 - When you want to unplug the power cord or any cable/wire, be sure to disconnect it by the plug head. Do not pull on the wire.
6. **Peripherals** – Turn off and detach any peripherals.
7. **Beware of static discharge.** ICs, such as the CPU and main support chips, are vulnerable to static electricity. Before handling any part in the computer, discharge any static electricity inside the computer. When handling a printed circuit board, do not use gloves or other materials which allow static electricity buildup. We suggest that you use an anti-static wrist strap instead.
8. **Beware of corrosion.** As you perform your job, avoid touching any connector leads. Even the cleanest hands produce oils which can attract corrosive elements.
9. **Keep your work environment clean.** Tobacco smoke, dust or other air-borne particulate matter is often attracted to charged surfaces, reducing performance.
10. **Keep track of the components.** When removing or replacing any part, be careful not to leave small parts, such as screws, loose inside the computer.

Cleaning

Do not apply cleaner directly to the computer, use a soft clean cloth.

Do not use volatile (petroleum distillates) or abrasive cleaners on any part of the computer.



Power Safety Warning

Before you undertake any upgrade procedures, make sure that you have turned off the power, and disconnected all peripherals and cables (including telephone lines). It is advisable to also remove your battery in order to prevent accidentally turning the machine on.

Disassembly Steps

The following table lists the disassembly steps, and on which page to find the related information. **PLEASE PERFORM THE DISASSEMBLY STEPS IN THE ORDER INDICATED.**

To remove the Battery:

1. Remove the battery [page 2 - 8](#)

To remove the HDD:

1. Remove the battery [page 2 - 8](#)
2. Remove the HDD [page 2 - 9](#)

To remove the System Memory:

1. Remove the battery [page 2 - 8](#)
2. Remove the system memory [page 2 - 10](#)

To remove the CD Device:

1. Remove the battery [page 2 - 8](#)
2. Remove the CD Device [page 2 - 12](#)

To remove the Bluetooth Module:

1. Remove the battery [page 2 - 8](#)
2. Remove the Bluetooth module [page 2 - 14](#)

To remove the Wireless LAN Module:

1. Remove the battery [page 2 - 8](#)
2. Remove the Wireless LAN module [page 2 - 15](#)

To remove the Processor:

1. Remove the battery [page 2 - 8](#)
2. Remove the processor [page 2 - 16](#)

To remove the Keyboard:

1. Remove the battery [page 2 - 8](#)
2. Remove the keyboard [page 2 - 18](#)

To remove the Keyboard Shielding Plate:

1. Remove the battery [page 2 - 8](#)
2. Remove the keyboard [page 2 - 18](#)
3. Remove the keyboard shielding plate [page 2 - 19](#)

To remove the LCD and Top Case:

1. Remove the battery [page 2 - 8](#)
2. Remove the HDD [page 2 - 9](#)
3. Remove the system memory [page 2 - 10](#)
4. Remove the CD Device [page 2 - 12](#)
5. Remove the Bluetooth module [page 2 - 14](#)
6. Remove the Wireless LAN module [page 2 - 15](#)
7. Remove the processor [page 2 - 16](#)
8. Remove the keyboard [page 2 - 18](#)
9. Remove the keyboard shielding plate [page 2 - 19](#)
10. Remove the LCD & top case [page 2 - 20](#)

To remove the TouchPad and Click Board:

1. Remove the battery *page 2 - 8*
2. Remove the HDD *page 2 - 9*
3. Remove the system memory *page 2 - 10*
4. Remove the CD Device *page 2 - 12*
5. Remove the Bluetooth module *page 2 - 14*
6. Remove the Wireless LAN module *page 2 - 15*
7. Remove the processor *page 2 - 16*
8. Remove the keyboard *page 2 - 18*
9. Remove the keyboard shielding plate *page 2 - 19*
10. Remove the LCD & top case *page 2 - 20*
11. Remove the touchpad and click board *page 2 - 22*

To remove the Switch Board:

1. Remove the battery *page 2 - 8*
2. Remove the HDD *page 2 - 9*
3. Remove the system memory *page 2 - 10*
4. Remove the CD Device *page 2 - 12*
5. Remove the Bluetooth module *page 2 - 14*
6. Remove the Wireless LAN module *page 2 - 15*
7. Remove the processor *page 2 - 16*
8. Remove the keyboard *page 2 - 18*
9. Remove the keyboard shielding plate *page 2 - 19*
10. Remove the LCD & top case *page 2 - 20*
11. Remove the switch board *page 2 - 23*

To remove the Modem:

1. Remove the battery *page 2 - 8*
2. Remove the HDD *page 2 - 9*
3. Remove the system memory *page 2 - 10*
4. Remove the CD Device *page 2 - 12*
5. Remove the Bluetooth module *page 2 - 14*
6. Remove the Wireless LAN module *page 2 - 15*
7. Remove the processor *page 2 - 16*
8. Remove the keyboard *page 2 - 18*
9. Remove the keyboard shielding plate *page 2 - 19*
10. Remove the LCD & top case *page 2 - 20*
11. Remove the modem *page 2 - 24*

To remove the Speakers:

1. Remove the battery *page 2 - 8*
2. Remove the HDD *page 2 - 9*
3. Remove the system memory *page 2 - 10*
4. Remove the CD Device *page 2 - 12*
5. Remove the Bluetooth module *page 2 - 14*
6. Remove the Wireless LAN module *page 2 - 15*
7. Remove the processor *page 2 - 16*
8. Remove the keyboard *page 2 - 18*
9. Remove the keyboard shielding plate *page 2 - 19*
10. Remove the LCD & top case *page 2 - 20*
11. Remove the speakers *page 2 - 25*

Disassembly

To remove the Mainboard:

1. Remove the battery *page 2 - 8*
2. Remove the HDD *page 2 - 9*
3. Remove the system memory *page 2 - 10*
4. Remove the CD Device *page 2 - 12*
5. Remove the Bluetooth module *page 2 - 14*
6. Remove the Wireless LAN module *page 2 - 15*
7. Remove the processor *page 2 - 16*
8. Remove the keyboard *page 2 - 18*
9. Remove the keyboard shielding plate *page 2 - 19*
10. Remove the LCD & top case *page 2 - 20*
11. Remove the speakers *page 2 - 25*
12. Remove the mainboard *page 2 - 26*

To remove the Fan Unit:

1. Remove the battery *page 2 - 8*
2. Remove the HDD *page 2 - 9*
3. Remove the system memory *page 2 - 10*
4. Remove the CD Device *page 2 - 12*
5. Remove the Bluetooth module *page 2 - 14*
6. Remove the Wireless LAN module *page 2 - 15*
7. Remove the processor *page 2 - 16*
8. Remove the keyboard *page 2 - 18*
9. Remove the keyboard shielding plate *page 2 - 19*
10. Remove the LCD & top case *page 2 - 20*
11. Remove the speakers *page 2 - 25*
12. Remove the mainboard *page 2 - 26*
13. Remove the fan unit *page 2 - 27*

To remove the Floppy Disk Drive Assembly:

1. Remove the battery *page 2 - 8*
2. Remove the HDD *page 2 - 9*
3. Remove the system memory *page 2 - 10*
4. Remove the CD Device *page 2 - 12*
5. Remove the Bluetooth module *page 2 - 14*
6. Remove the Wireless LAN module *page 2 - 15*
7. Remove the processor *page 2 - 16*
8. Remove the keyboard *page 2 - 18*
9. Remove the keyboard shielding plate *page 2 - 19*
10. Remove the LCD & top case *page 2 - 20*
11. Remove the speakers *page 2 - 25*
12. Remove the mainboard *page 2 - 26*
13. Remove the floppy disk drive *page 2 - 28*

To remove the PC Card Assembly:

1. Remove the battery *page 2 - 8*
2. Remove the HDD *page 2 - 9*
3. Remove the system memory *page 2 - 10*
4. Remove the CD Device *page 2 - 12*
5. Remove the Bluetooth module *page 2 - 14*
6. Remove the Wireless LAN module *page 2 - 15*
7. Remove the processor *page 2 - 16*
8. Remove the keyboard *page 2 - 18*
9. Remove the keyboard shielding plate *page 2 - 19*
10. Remove the LCD & top case *page 2 - 20*
11. Remove the speakers *page 2 - 25*
12. Remove the mainboard *page 2 - 26*
13. Remove the PC Card assembly *page 2 - 29*

To remove the LCD Front Panel Module:

1. Remove the battery *page 2 - 8*
2. Remove the HDD *page 2 - 9*
3. Remove the system memory *page 2 - 10*
4. Remove the CD Device *page 2 - 12*
5. Remove the Bluetooth module *page 2 - 14*
6. Remove the Wireless LAN module *page 2 - 15*
7. Remove the processor *page 2 - 16*
8. Remove the keyboard *page 2 - 18*
9. Remove the keyboard shielding plate *page 2 - 19*
10. Remove the LCD & top case *page 2 - 20*
11. Remove the front panel module *page 2 - 30*

To remove the Inverter:

1. Remove the battery *page 2 - 8*
2. Remove the HDD *page 2 - 9*
3. Remove the system memory *page 2 - 10*
4. Remove the CD Device *page 2 - 12*
5. Remove the Bluetooth module *page 2 - 14*
6. Remove the Wireless LAN module *page 2 - 15*
7. Remove the processor *page 2 - 16*
8. Remove the keyboard *page 2 - 18*
9. Remove the keyboard shielding plate *page 2 - 19*
10. Remove the LCD & top case *page 2 - 20*
11. Remove the front panel module *page 2 - 30*
12. Remove the inverter *page 2 - 31*

To remove the PC Video Camera Module:

1. Remove the battery *page 2 - 8*
2. Remove the HDD *page 2 - 9*
3. Remove the system memory *page 2 - 10*
4. Remove the CD Device *page 2 - 12*
5. Remove the Bluetooth module *page 2 - 14*
6. Remove the Wireless LAN module *page 2 - 15*
7. Remove the processor *page 2 - 16*
8. Remove the keyboard *page 2 - 18*
9. Remove the keyboard shielding plate *page 2 - 19*
10. Remove the LCD & top case *page 2 - 20*
11. Remove the front panel module *page 2 - 30*
12. Remove the PC Video Camera *page 2 - 32*

To remove the LCD Module:

1. Remove the battery *page 2 - 8*
2. Remove the HDD *page 2 - 9*
3. Remove the system memory *page 2 - 10*
4. Remove the CD Device *page 2 - 12*
5. Remove the Bluetooth module *page 2 - 14*
6. Remove the Wireless LAN module *page 2 - 15*
7. Remove the processor *page 2 - 16*
8. Remove the keyboard *page 2 - 18*
9. Remove the keyboard shielding plate *page 2 - 19*
10. Remove the LCD & top case *page 2 - 20*
11. Remove the front panel module *page 2 - 30*
12. Remove the inverter *page 2 - 31*
13. Remove the LCD module *page 2 - 33*

Removing the Battery

1. Turn the computer **off**, and turn it over.
2. Remove screws **1** & **2** (**Figure 1a**) from the battery cover **3**, and remove the cover.
3. Carefully (use a small screwdriver) disconnect the battery cable at point **4** (**Figure 1b**).
4. Lift the battery **5** out of the computer.
5. When replacing the battery, connect the cable first.

Figure 1
Battery Removal

- a. Remove the 2 screws and the battery cover.
- b. Carefully disconnect the battery cable and remove the battery.

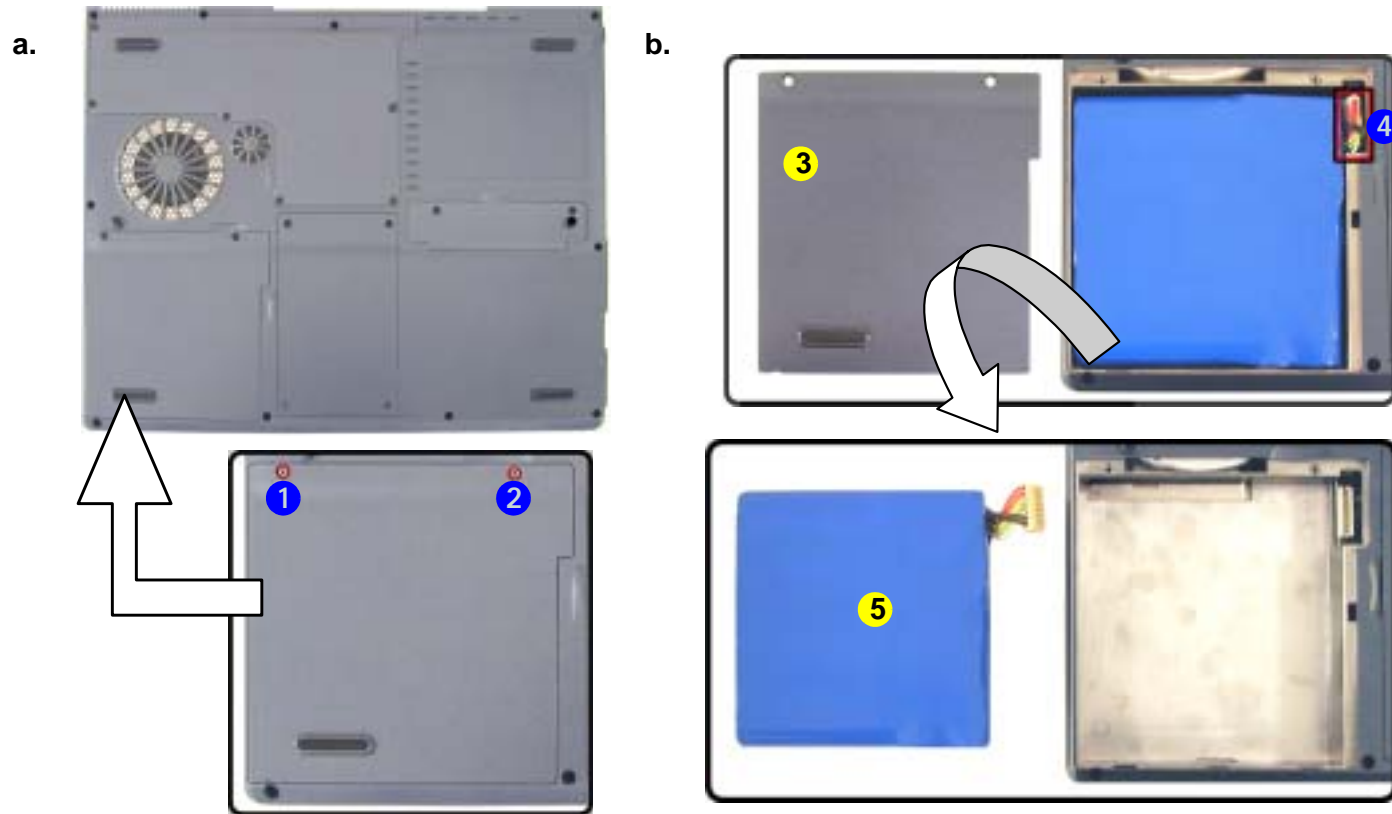

- 3. Battery Cover
- 5. Battery
- 2 Screws

Removing the Hard Disk Drive

The hard disk drive is mounted in a removable case and can be taken out to accommodate other 2.5" IDE hard disk drives with a height of 9.5mm (h). Follow your operating system's installation instructions, and install all necessary drivers and utilities (as outlined in **Chapter 4 of the User's Manual**) when setting up a new hard disk.

Hard Disk Upgrade Process

1. Turn **off** the computer, remove the battery ([page 2 - 8](#)) and turn it over.
2. Remove screws **1** & **4** (**Figure 2a**) from the hard disk cover **5**, and remove the cover.
3. Carefully (use a small screwdriver) disconnect the battery cable at point **6** (**Figure 2b**).
4. Lift the HDD assembly **7** out of the computer.
5. Reverse the process to install a new hard disk.

HDD System Warning

New HDD's are blank. Before you begin make sure:

- You have backed up any data you want to keep from your old HDD.
- You have all the CD-ROMs and FDDs required to install your operating system and programs.
- If you have access to the internet, download the latest application and hardware driver updates for the operating system you plan to install. Copy these to a removable medium.

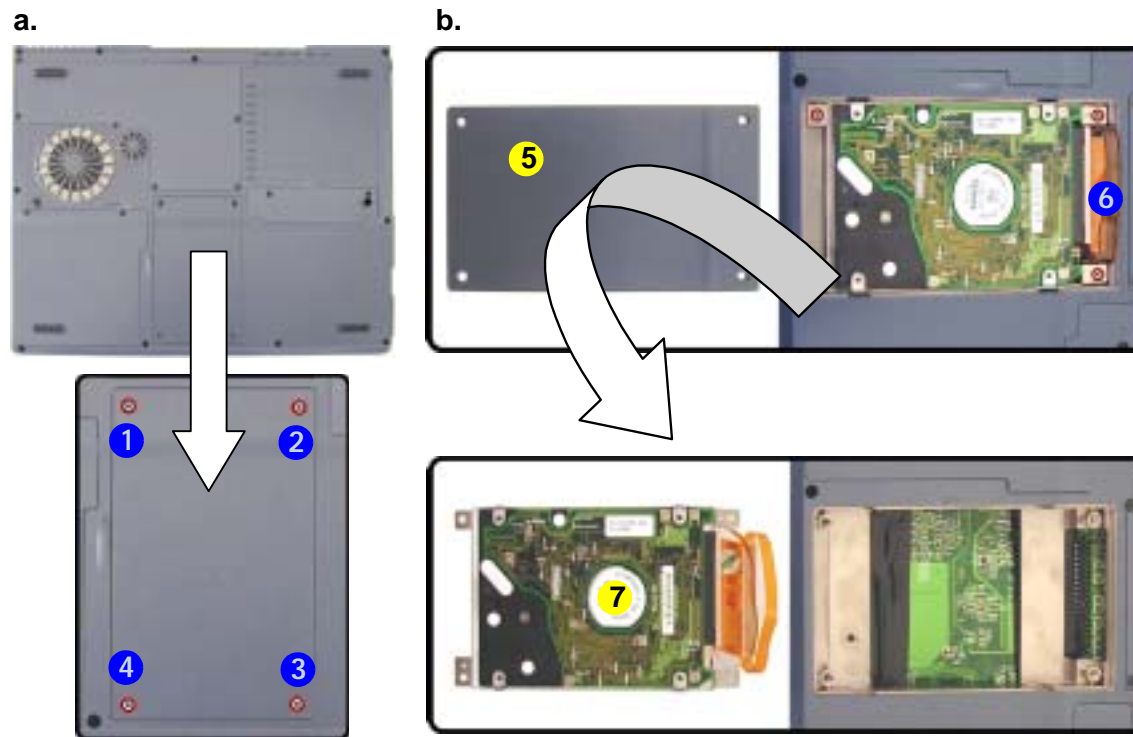

Figure 2
**HDD Assembly
Assembly Removal**

- a. Remove the 4 screws.
- b. Disconnect the HDD cable and lift the HDD assembly out of the bay.



- 5. Hard Disk Cover
- 7. Hard Disk
- 4 Screws

Removing the System Memory (RAM)

The computer has two memory sockets for 200 pin Small Outline Dual In-line Memory Modules (SO-DIMM) supporting DDR 200/266/333MHz. The main memory can be expanded up to 1024MB. The SO-DIMM modules supported are 128Mb, 256Mb, and 512Mb. The total memory size is automatically detected by the POST routine once you turn on your computer.

Memory Upgrade Process

1. Turn **off** the computer, remove the battery ([page 2 - 8](#)) and turn it over.
2. Remove screws **1** - **6** (**Figure 3a**) from the memory socket cover.
3. Carefully lift up the memory socket cover **7** (**Figure 3b**) (a fan cable **8** is still attached to the mainboard and you can disconnect it).
4. If there is a module currently installed which needs to be upgraded/replaced then remove it.

Figure 3
Memory Socket Cover Removal

- a. Remove the screws.
- b. Carefully lift the cover off the computer.

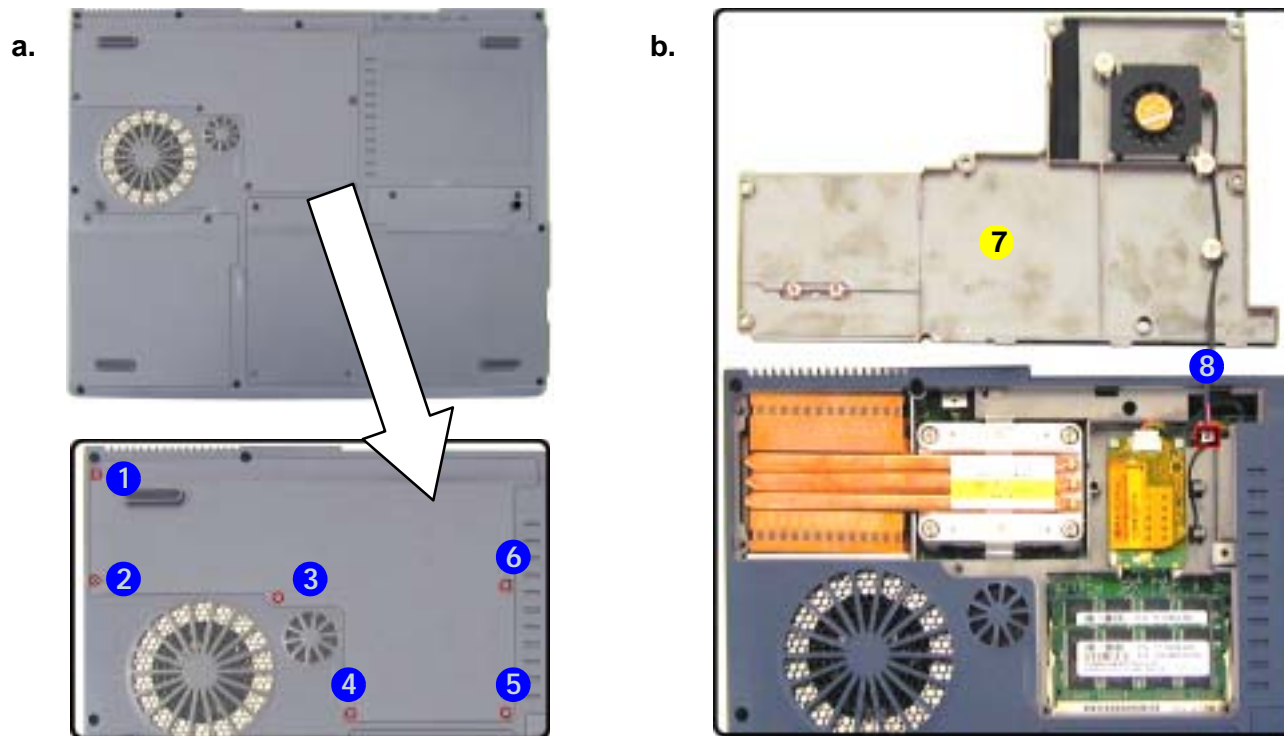

7. Socket Cover

- 6 Screws

- Gently pull the two release latches (1 & 2) on the sides of the memory socket toward the sides of the computer.

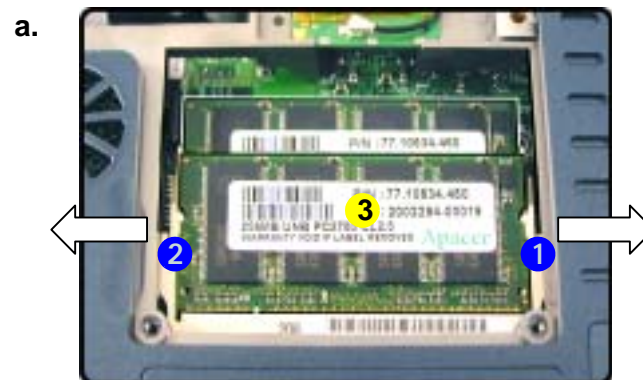

- The module 3 (Figure 4b) will pop-up, and you can remove it.
- Repeat the process for the second module if necessary.
- Insert a new module holding it at about a 30° angle and fit the connectors firmly into the memory slot.
- The module will only fit one way as defined by its pin alignment. Make sure the module is seated as far into the slot as it will go. DO NOT FORCE IT; it should fit without much pressure.

b.



- Press the module down towards the mainboard until the slot levers click into place to secure the module.
- Replace the memory socket cover (be careful with the fan cable) and the 6 screws (see [page 2 - 10](#)).
- Restart the computer.
- The BIOS will register the new memory configuration as it starts up.

Figure 4
**Removing/
Installing a RAM
Module**

- Pull the release latches.
- Remove the module.



Contact Warning

Be careful not to touch the metal pins on the module's connecting edge. Even the cleanest hands have oils which can attract particles, and degrade the module's performance.



3. RAM Module

Removing the CD Device

The easy changeable CD device may be upgraded or changed.

1. Turn **off** the computer, remove the battery ([page 2 - 8](#)) and turn it over.
2. Remove screws **1** - **6** (**Figure 5a**) from the memory socket cover.
3. Carefully lift up the memory socket cover **7** (a fan cable **8** is still attached to the mainboard and you can disconnect it).

Figure 5
**Memory Socket
Cover Removal**

- a. Remove the screws.
- b. Carefully lift the cover off the computer.

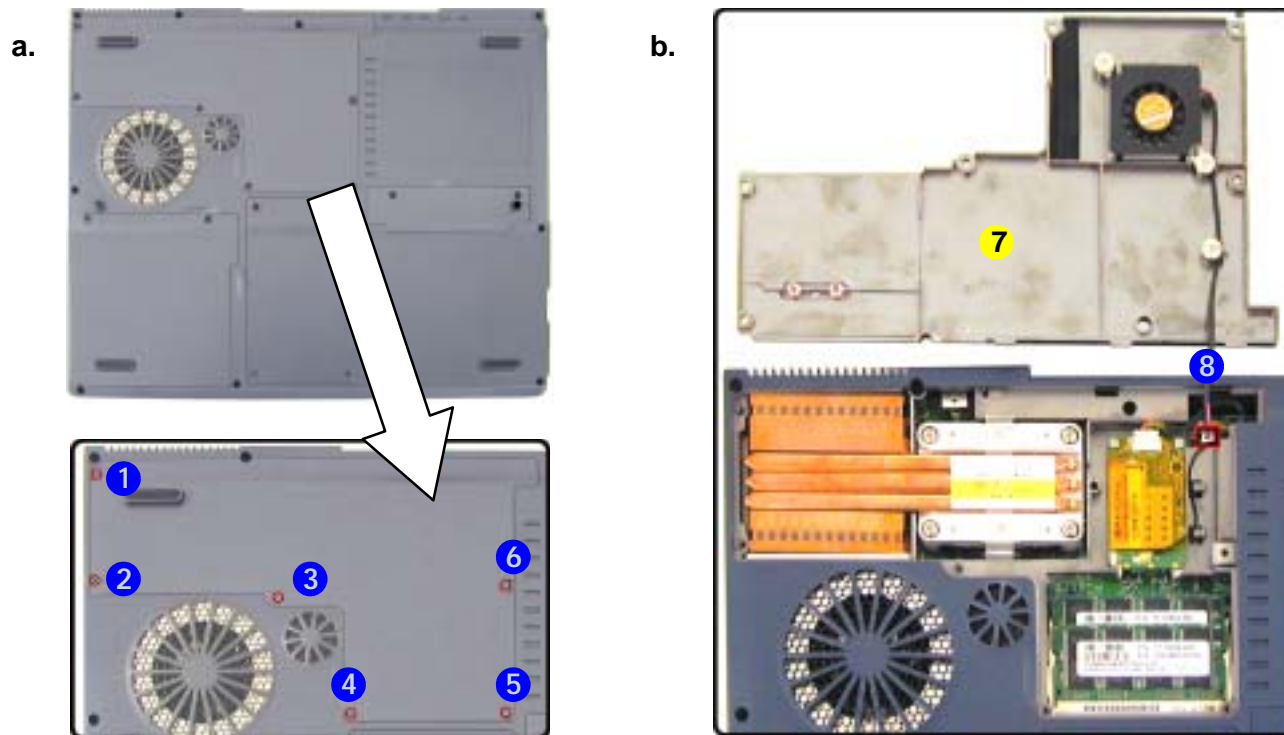

- 7. Socket Cover
- 6 Screws

4. Use a screwdriver to carefully push the CD device assembly **1** out of the computer at point **2**.

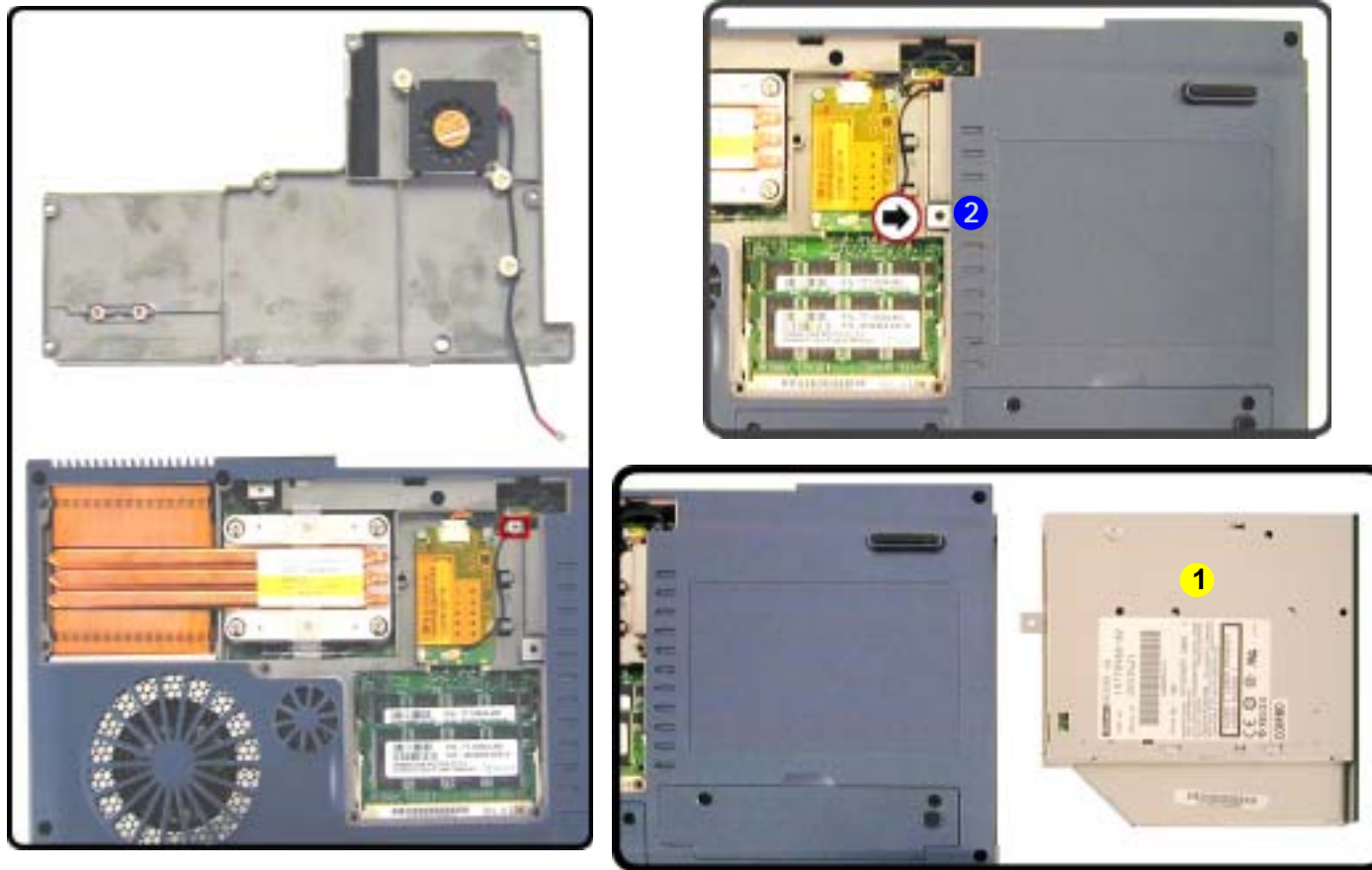

Figure 6
CD Device Removal

Push the CD device out off the computer at point 2.

5. Insert the new device and carefully slide it into the computer (the device only fits one way. DO NOT FORCE IT; The screw holes should line up).
6. Replace the memory socket cover (be careful with the fan cable) and the **6** screws (see [page 2 - 12](#)).
7. Restart the computer to allow it to automatically detect the new device.



1. CD Device

Removing the Bluetooth Module

1. Turn **off** the computer, remove the battery ([page 2 - 8](#)) and turn it over.
2. Remove screws **1** - **2** (**Figure 7a**) from the Bluetooth module cover.
3. Carefully lift up the Bluetooth module cover **3** off the computer.
4. Remove screws **3** - **6** (**Figure 7c**) and carefully disconnect cables **8** - **9**, then remove the Bluetooth module **10** (**Figure 7d**).

Figure 7
Bluetooth Module Removal

- a. Remove the screws.
- b. Carefully lift the cover off the computer.
- c. Remove the screws and disconnect the cables.
- d. Remove the Bluetooth module.

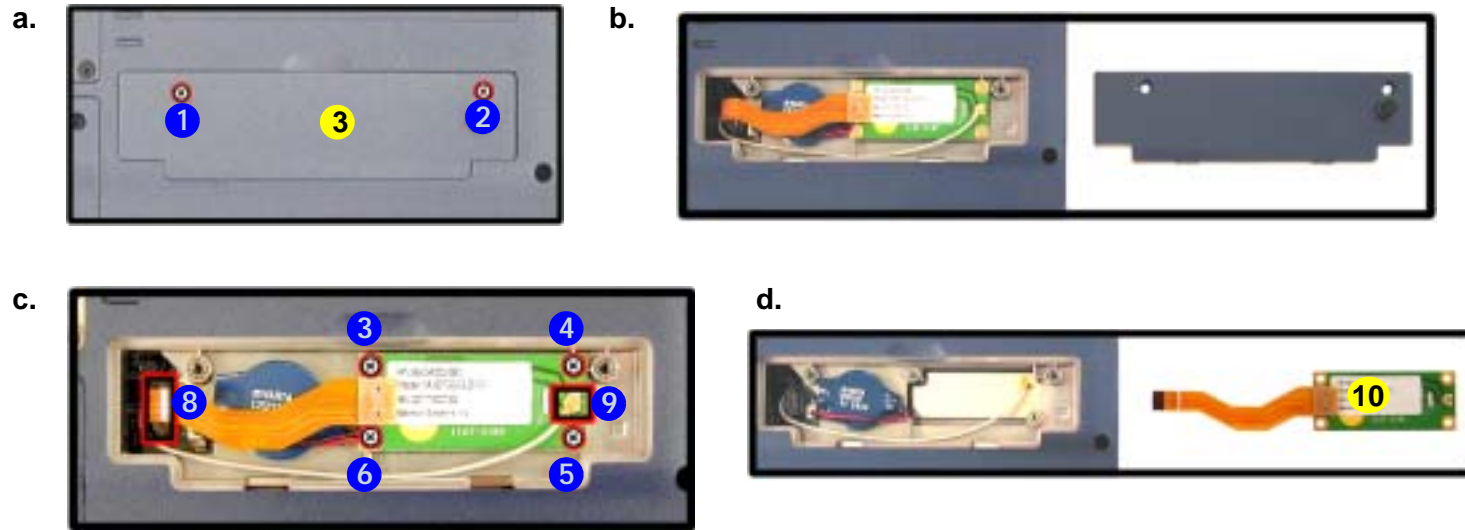

3. Bluetooth Cover
10. Bluetooth Module

- 6 Screws

Removing the Wireless LAN Module

1. Turn **off** the computer, remove the battery ([page 2 - 8](#)) and turn it over.
2. Remove screws **1** - **6** from the memory socket cover.
3. Carefully lift up the memory socket cover **7** (a fan cable **8** is still attached to the mainboard and you can disconnect it).
4. Remove screws **9** - **10** (**Figure 8c**), and carefully disconnect cables **11** & **12**.
5. Lift the Wireless Lan module **13** (**Figure 8d**) off the computer.

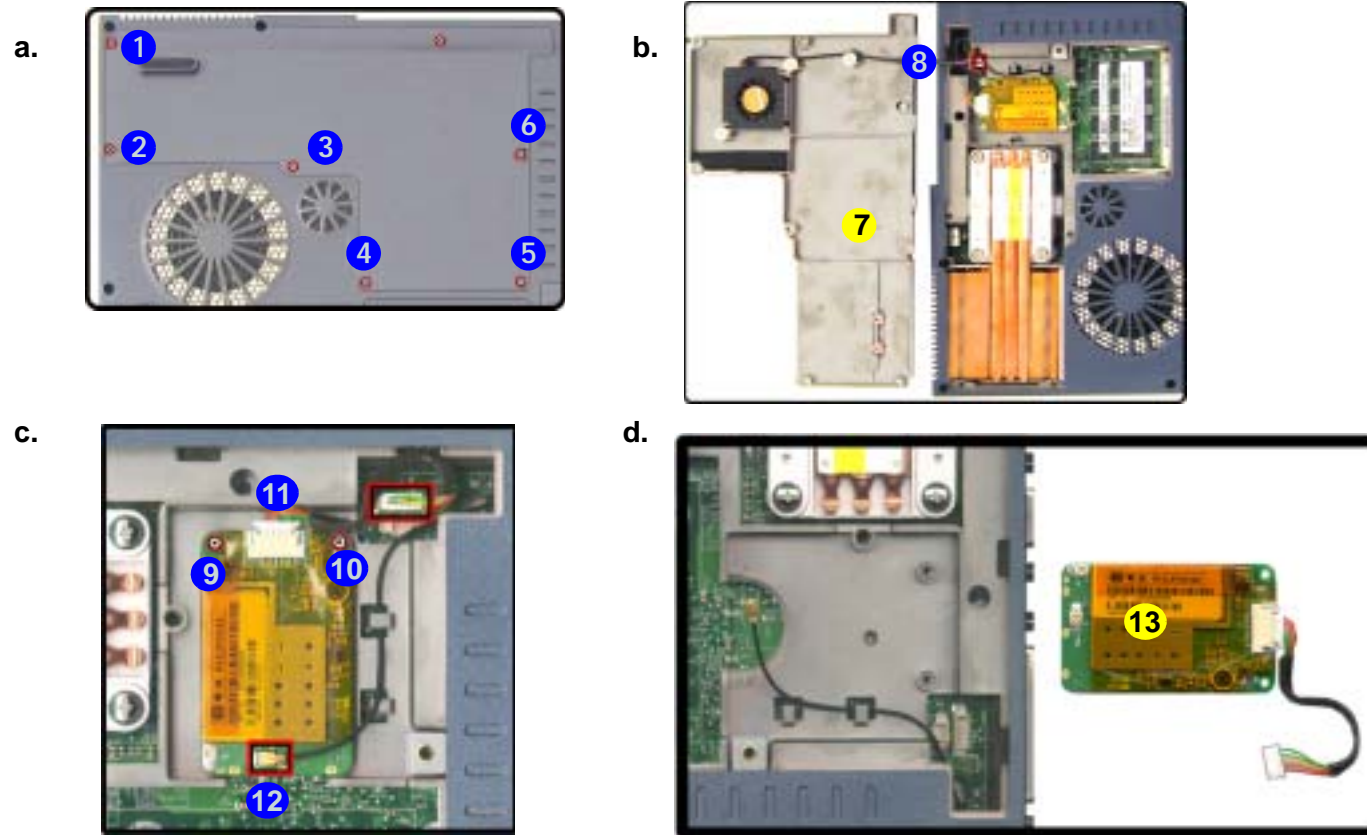

Figure 8
**Wireless LAN
Module Removal**

- a. Remove the screws.
- b. Carefully lift the cover off the computer.



Antenna Cable Connection

When re-inserting a Wireless LAN module, make sure the antenna cable connects to the connector **J1** which is indicated as point **12** in **Figure 8c**.



7. Socket Cover
13. WLAN Module

- 8 Screws

Removing the Processor

1. Turn **off** the computer, remove the battery ([page 2 - 8](#)) and turn it over.
2. Remove screws **1** - **6** from the memory socket cover.
3. Carefully lift up the memory socket cover **7** (a fan cable **8** is still attached to the mainboard and you can disconnect it).
4. Remove screws **9** - **12** (**Figure 9c**) from the heat sink, **in the order indicated on the label**.
5. Carefully lift up the heat sink **13** (**Figure 9d**) off the computer.

Figure 9

Processor Removal

- a. Remove the screws.
- b. Carefully lift the cover off the computer.
- c. Remove the screws in the order indicated.
- d. Remove the heat sink.

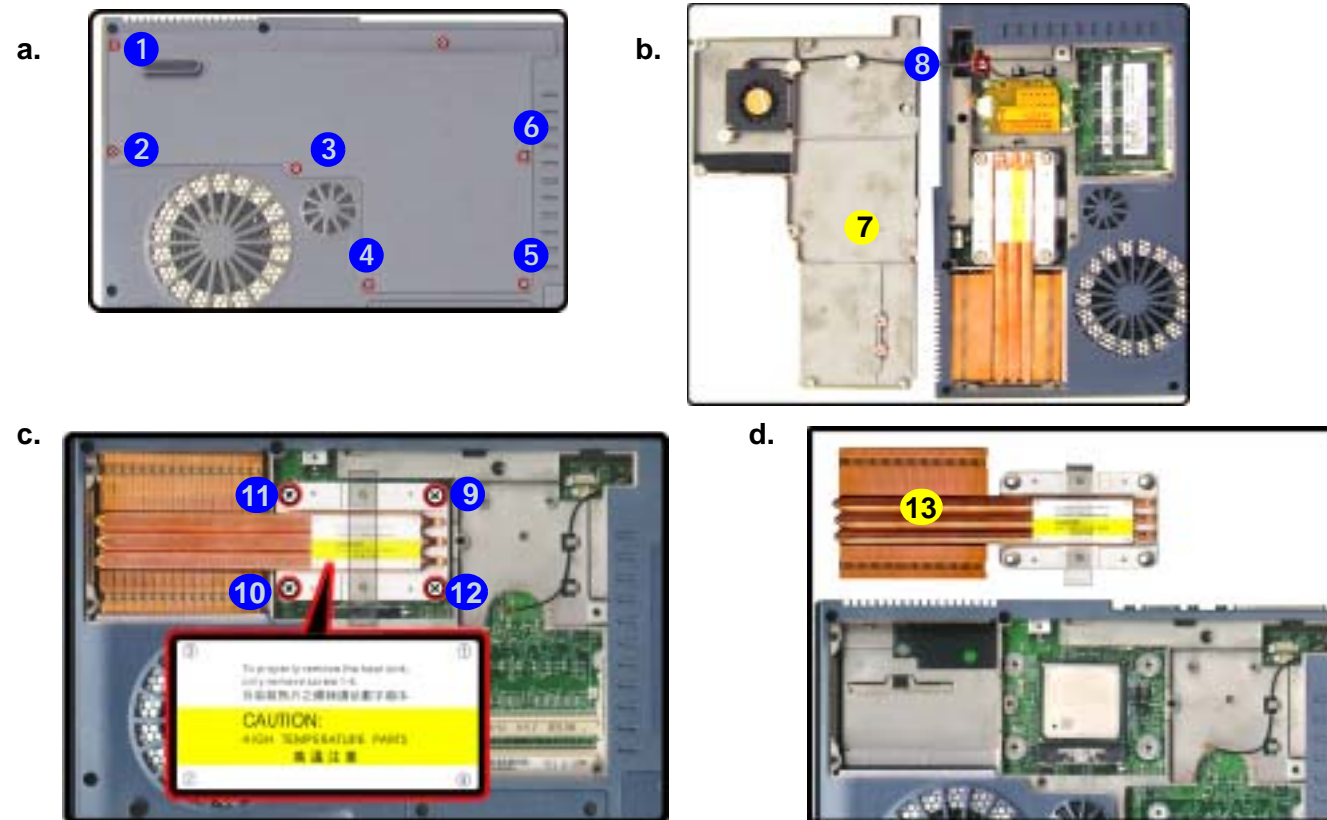

Reassembly Screw Order

When replacing the heat sink, make sure you insert the screws in the same order indicated on the label.



7. Socket Cover
13. Heat Sink

- 10 Screws

- Use a screwdriver to unlock the CPU by giving the lock ① (Figure 10a) a turn to the left.
- Lift the CPU ③ (Figure 10c) off the computer (make sure the lock is fully turned to the left as the CPU will lift off with ease).

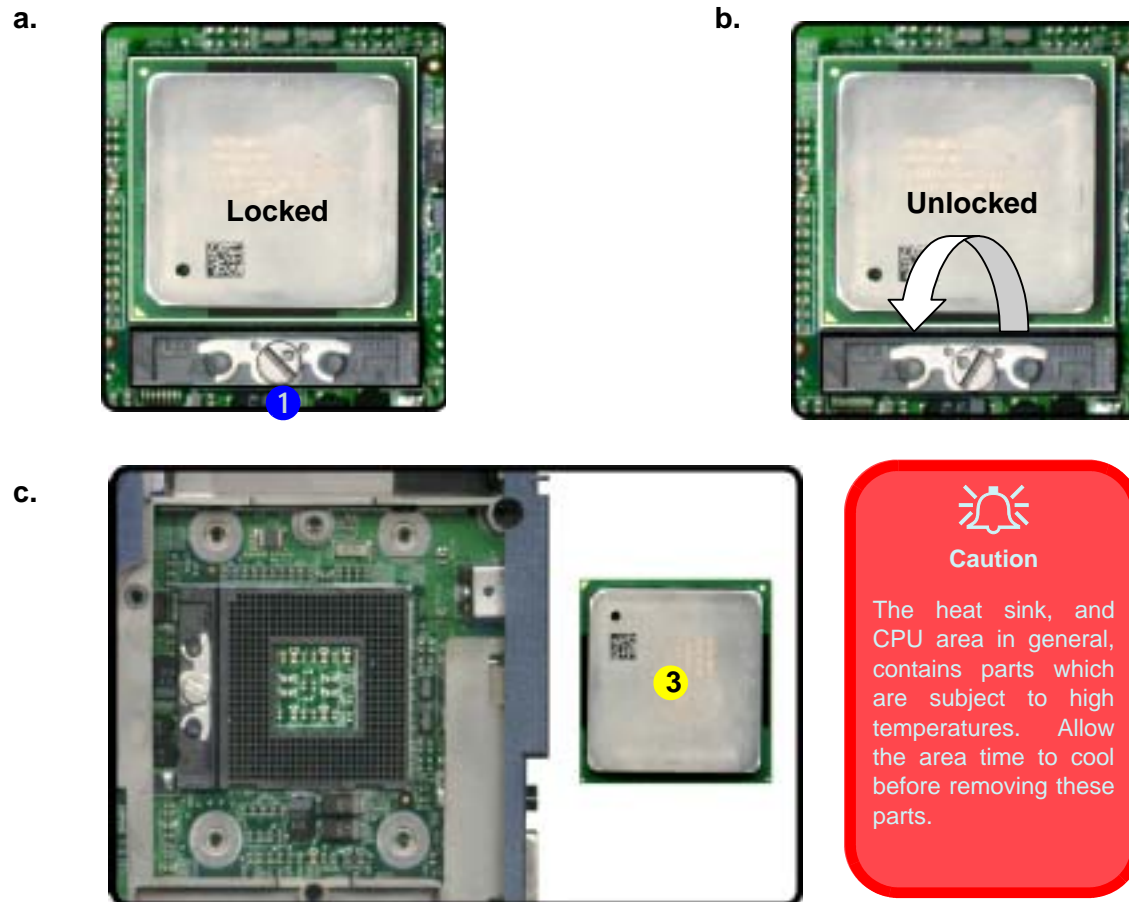
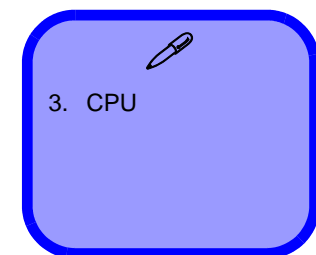

Figure 10
**Processor Removal
(cont'd)**

- Locate the CPU lock.
- Turn the lock to the left to unlock it.
- Remove the CPU.



Removing the Keyboard

1. Turn **off** the computer, remove the battery ([page 2 - 8](#)).
2. Press the **three** keyboard latches at the top of the keyboard to elevate the keyboard from its normal position (you may need to use a small screwdriver to do this).
3. Carefully lift the keyboard up and out, being careful not to bend the keyboard ribbon cable **1** (**Figure 11b**).
4. Disconnect the keyboard ribbon cable from the locking collar socket **2** (**Figure 11b**) and lift the keyboard **3** up out of the computer.

Figure 11
Keyboard Removal

- a. Press the latches to elevate the keyboard.
- b. Disconnect the keyboard cable from the locking collar.
- c. Remove the keyboard.

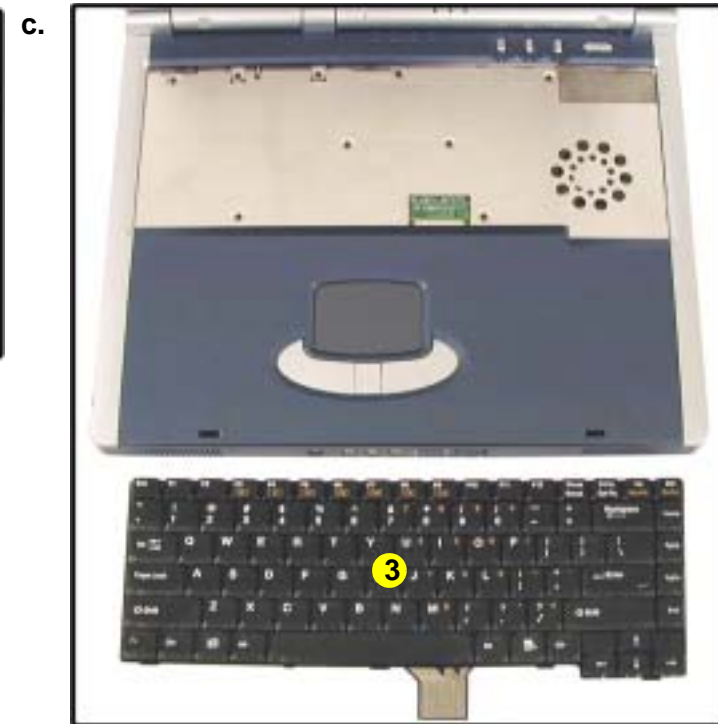
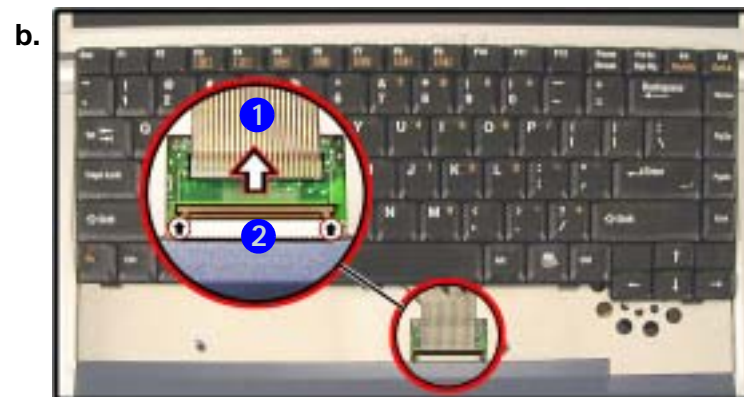

3. Keyboard

Removing the Keyboard Shielding Plate

1. Turn **off** the computer, remove the battery ([page 2 - 8](#)) and keyboard ([page 2 - 18](#)).
2. Remove screws **1** - **9** (**Figure 12a**) from the keyboard shielding plate and lift the plate **10** off the computer.

a.

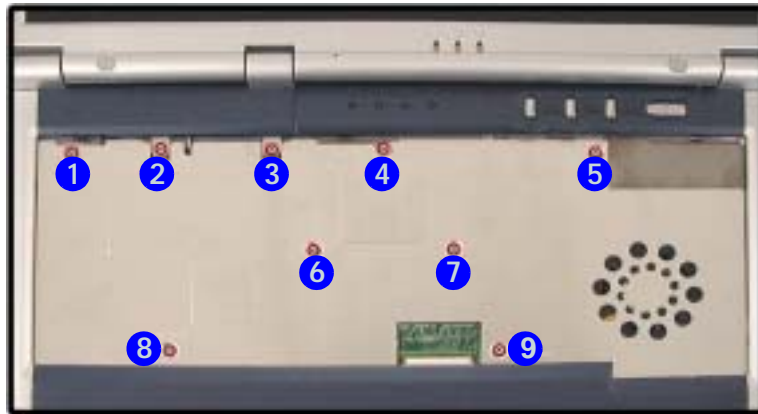

b.

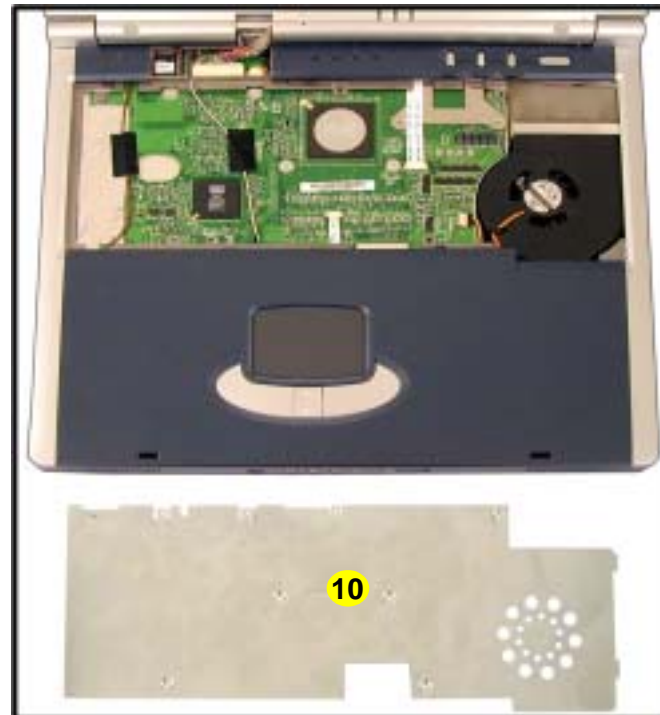

Figure 12
Keyboard Shielding Plate Removal

- a. Remove the screws from the shielding plate.
- b. Lift the plate off the computer.



10. Shielding Plate

- 9 Screws

Removing the LCD and Top Case

1. Turn **off** the computer, remove the battery ([page 2 - 8](#)), hard disk ([page 2 - 9](#)), RAM ([page 2 - 10](#)), CD Device ([page 2 - 12](#)), Bluetooth module ([page 2 - 14](#)), Wireless LAN module ([page 2 - 15](#)), CPU ([page 2 - 16](#)), keyboard ([page 2 - 18](#)) and keyboard shielding plate ([page 2 - 19](#)).
2. Remove screws **1 - 10**, and disconnect cable **11** (**Figure 13a**) from the bottom off the computer.
3. Remove screws **12 - 21** (**Figure 13b**) from the rear off the computer.
4. Remove the LCD cable shielding cover **26**, screws **22 - 23** and disconnect cables **24 - 25** (**Figure 13c**).

Figure 13
LCD & Top Case Removal

- a. Remove the screws from the bottom of the computer.
- b. Remove the screws from the rear of the computer.
- c. Remove the LCD cable shielding cover and disconnect the cables.

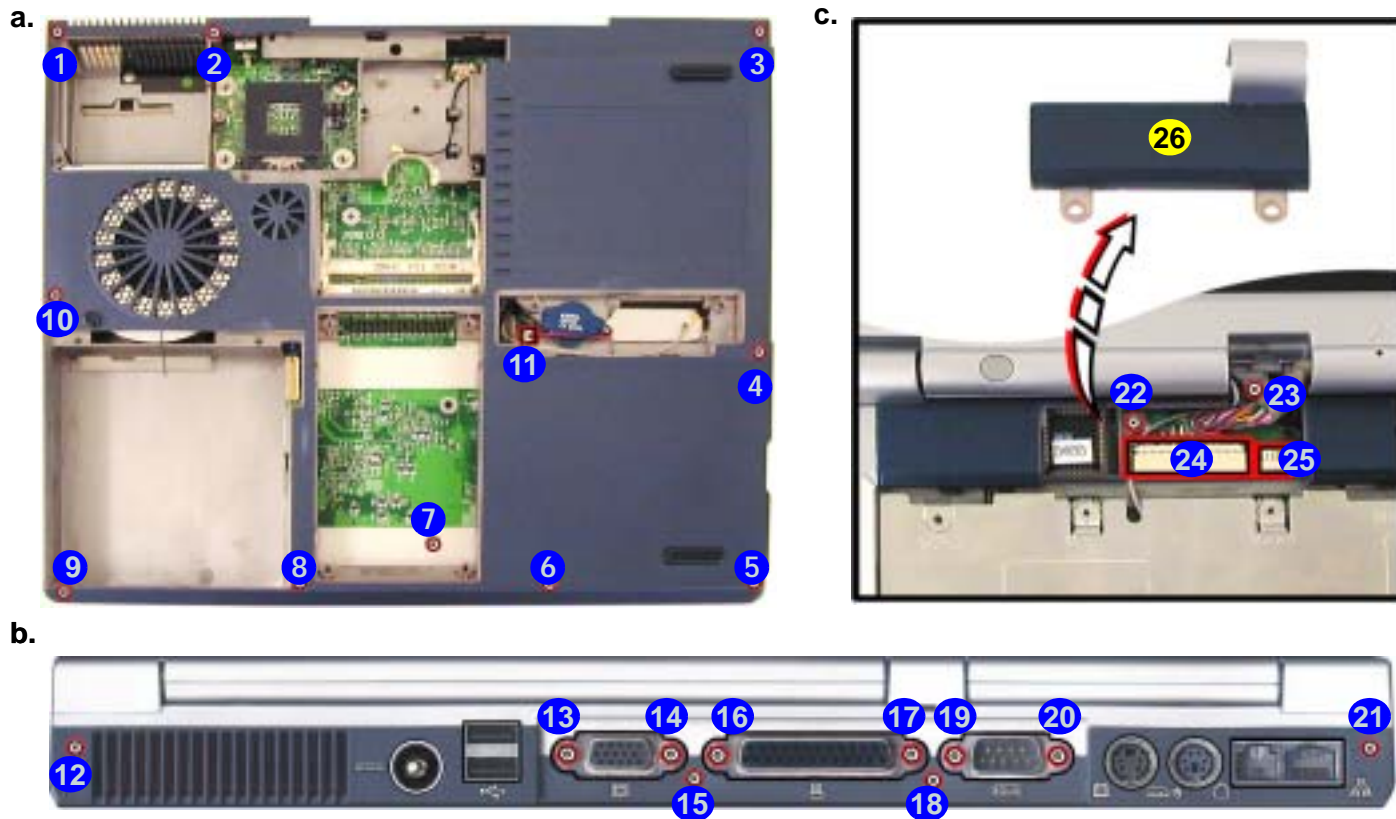



26. LCD cable cover

- 20 Screws

5. Slide the LCD hinge covers **1** & **2** (Figure 14a) out of the computer.
6. Remove screws **3** & **4** (Figure 14b) then carefully (pay careful attention to the antenna cables) lift the LCD assembly **5** (Figure 14c) off the computer.
7. Remove screws **6** & **7** (Figure 14d) and disconnect cables **8** & **9**, then lift the top case assembly **10** off the computer.

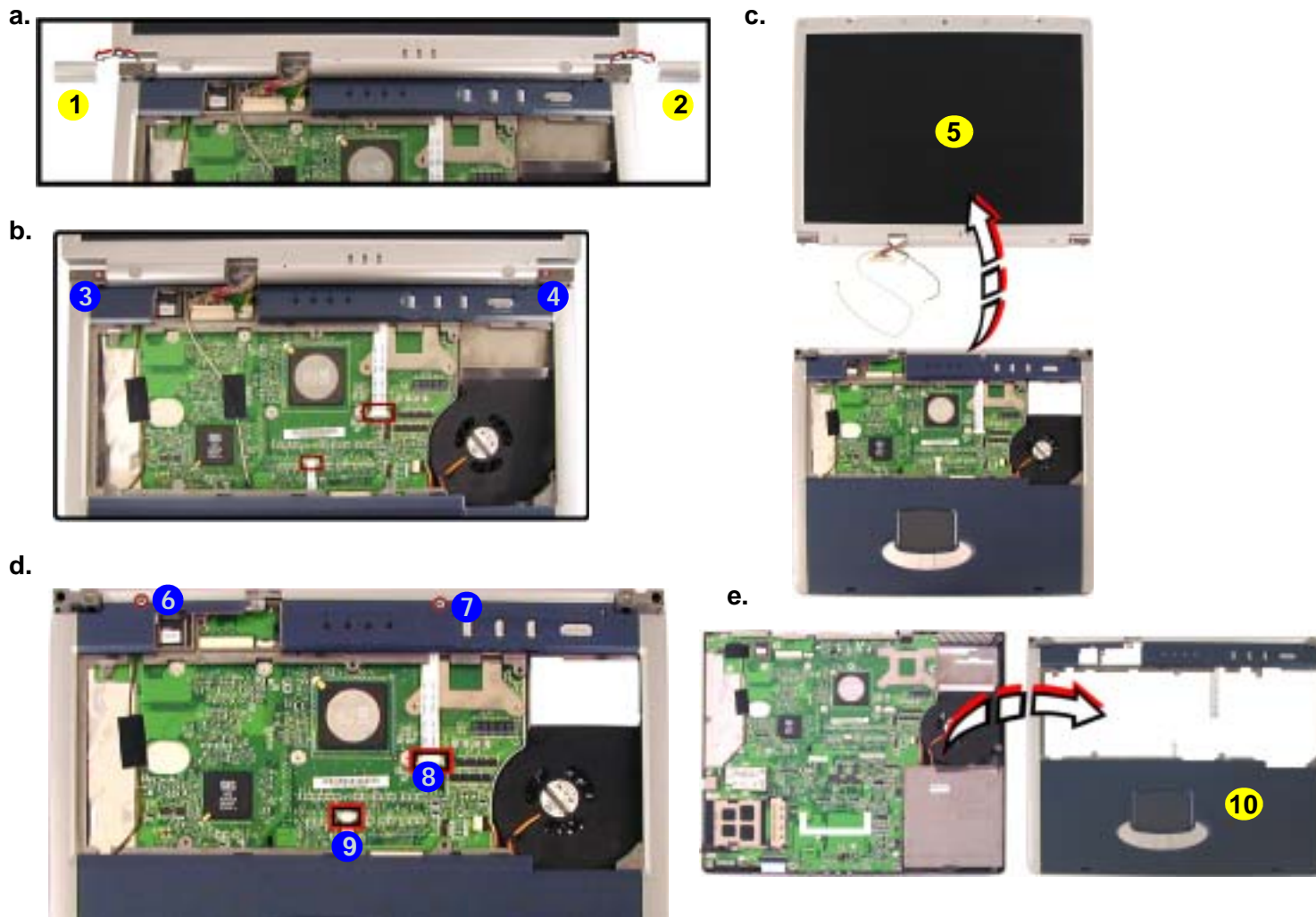



Figure 14
LCD & Top Case
Removal Cont'd

- a. Remove the hinge covers.
- b. Remove the screws from the LCD.
- c. Lift the LCD top case assembly.
- d. Remove the screws and disconnect the cables.
- e. Lift the top case assembly off the computer.



1&2. Hinge covers
5. LCD Assembly
10. Top Case

- 4 Screws

Removing the TouchPad and Click Board

1. Turn **off** the computer, remove the battery ([page 2 - 8](#)), hard disk ([page 2 - 9](#)), RAM ([page 2 - 10](#)), CD Device ([page 2 - 12](#)), Bluetooth module ([page 2 - 14](#)), Wireless LAN module ([page 2 - 15](#)), CPU ([page 2 - 16](#)), keyboard ([page 2 - 18](#)), keyboard shielding plate ([page 2 - 19](#)) and the top case and LCD ([page 2 - 20](#)).
2. Remove screws **1** - **8** (**Figure 15a**) from the touchpad and click board assembly, and lift the assembly off the top case.
3. Disconnect cable **9** (**Figure 15c**) and remove screws **10** - **11** (**Figure 15d**).
4. Separate the touchpad **12** and click board **13** (**Figure 15e**).

Figure 15

TouchPad and Click Board Removal

- a. Remove the screws.
- b. Separate the assembly from the top case.
- c. Disconnect the cable.
- d. Remove the screws.
- e. Separate the touchpad and click board.

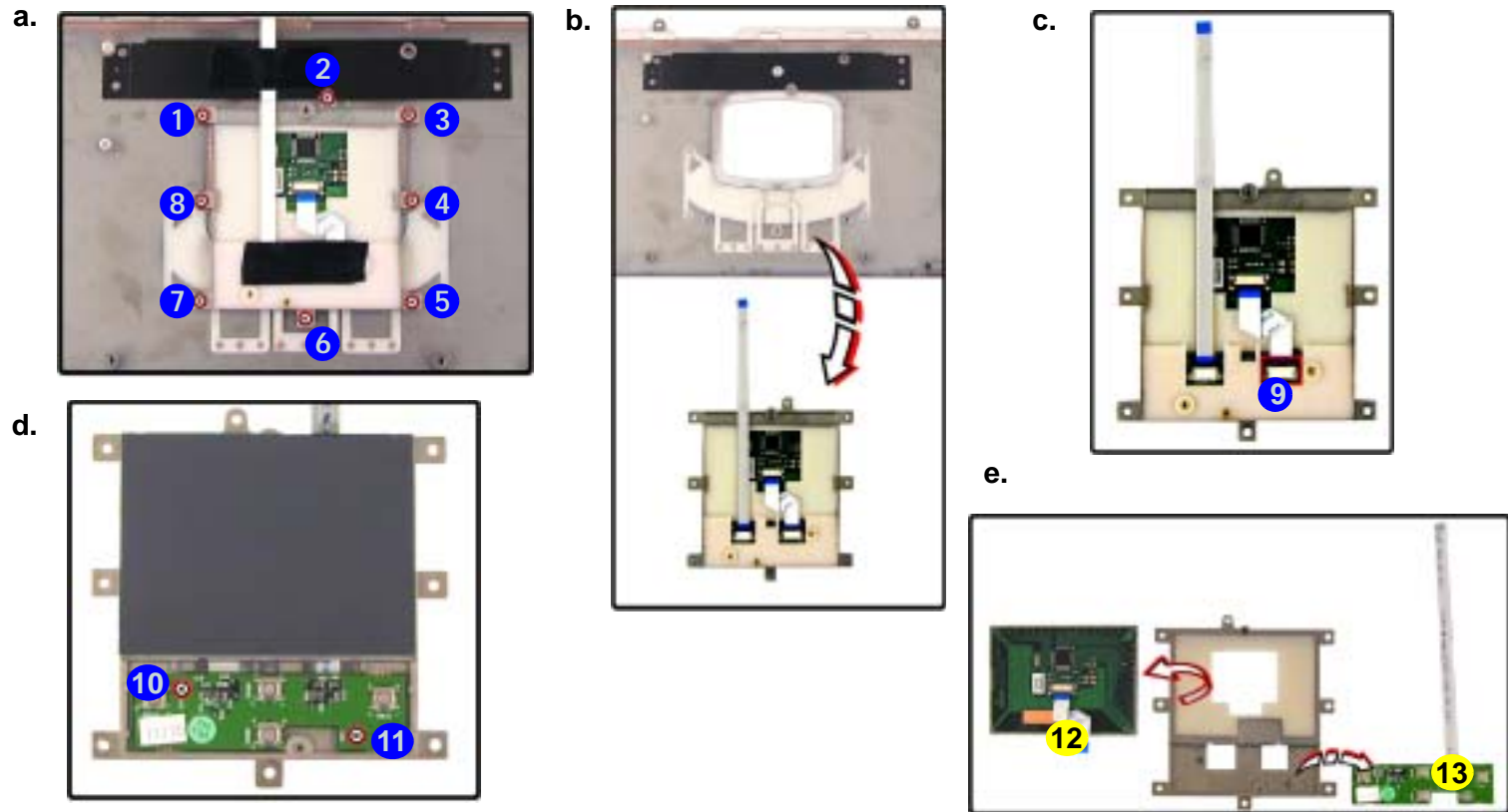

12. Touch Pad
13. Click Board

- 10 Screws

Removing the Switch Board

1. Turn **off** the computer, remove the battery ([page 2 - 8](#)), hard disk ([page 2 - 9](#)), RAM ([page 2 - 10](#)), CD Device ([page 2 - 12](#)), Bluetooth module ([page 2 - 14](#)), Wireless LAN module ([page 2 - 15](#)), CPU ([page 2 - 16](#)), keyboard ([page 2 - 18](#)), keyboard shielding plate ([page 2 - 19](#)) and the top case and LCD ([page 2 - 20](#)). ⑩
2. Remove screws ① & ② (**Figure 16a**) from the switch board assembly.
3. Lift the switch board assembly ③ (**Figure 16b**) off the top case.

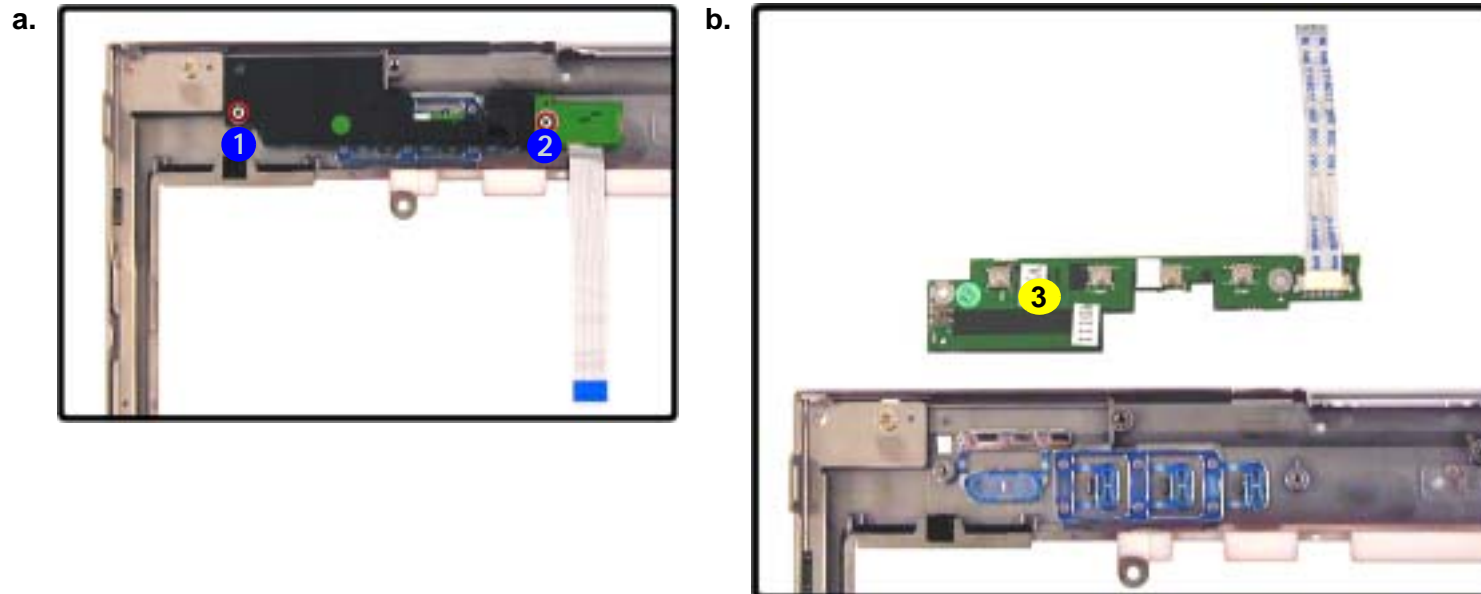

Figure 16
**Switch Board
Removal**

- a. Remove the screws.
- b. Lift the switch board assembly off the top case.



3. Switch Board
- 2 Screws

Removing the Modem

1. Turn **off** the computer, remove the battery ([page 2 - 8](#)), hard disk ([page 2 - 9](#)), RAM ([page 2 - 10](#)), CD Device ([page 2 - 12](#)), Bluetooth module ([page 2 - 14](#)), Wireless LAN module ([page 2 - 15](#)), CPU ([page 2 - 16](#)), keyboard ([page 2 - 18](#)), keyboard shielding plate ([page 2 - 19](#)) and the top case and LCD ([page 2 - 20](#)).
2. Remove screws **1** & **2** (**Figure 17**) from the modem and disconnect cable **3**.
3. Remove the modem module **4**.

Figure 17

Modem Removal

Remove the screws, disconnect the cable, and remove the modem module.

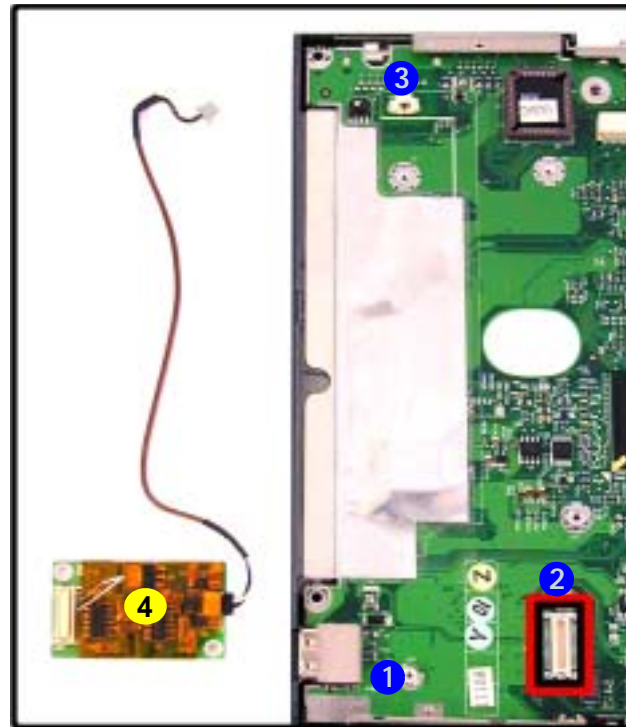

- 4. Modem
- 2 Screws

Removing the Speakers

1. Turn **off** the computer, remove the battery ([page 2 - 8](#)), hard disk ([page 2 - 9](#)), RAM ([page 2 - 10](#)), CD Device ([page 2 - 12](#)), Bluetooth module ([page 2 - 14](#)), Wireless LAN module ([page 2 - 15](#)), CPU ([page 2 - 16](#)), keyboard ([page 2 - 18](#)), keyboard shielding plate ([page 2 - 19](#)) and the top case and LCD ([page 2 - 20](#)).
2. Disconnect cables **1** & **2** (**Figure 18a**) from the speakers to the mainboard.
3. Remove the speakers **3** (**Figure 18b**).

a.

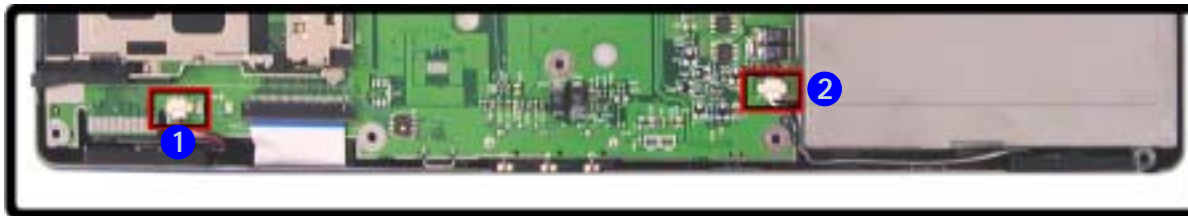

b.



Figure 18
Speakers Removal

- a. Disconnect the cables.
- b. Remove the speakers.



3. Speakers

Removing the Mainboard

1. Turn **off** the computer, remove the battery ([page 2 - 8](#)), hard disk ([page 2 - 9](#)), RAM ([page 2 - 10](#)), CD Device ([page 2 - 12](#)), Bluetooth module ([page 2 - 14](#)), Wireless LAN module ([page 2 - 15](#)), CPU ([page 2 - 16](#)), keyboard ([page 2 - 18](#)), keyboard shielding plate ([page 2 - 19](#)), the top case and LCD ([page 2 - 20](#)) and speakers ([page 2 - 25](#)).
2. Disconnect cables **1** & **2** (**Figure 19a**) and remove screws **3** & **4**.
3. Separate the mainboard **5**, rear bracket **6** and bottom case **7** (**Figure 19b**).

Figure 19

Mainboard Removal

- a. Disconnect the cables and remove the screws.
- b. Separate the mainboard, rear bracket and bottom case.

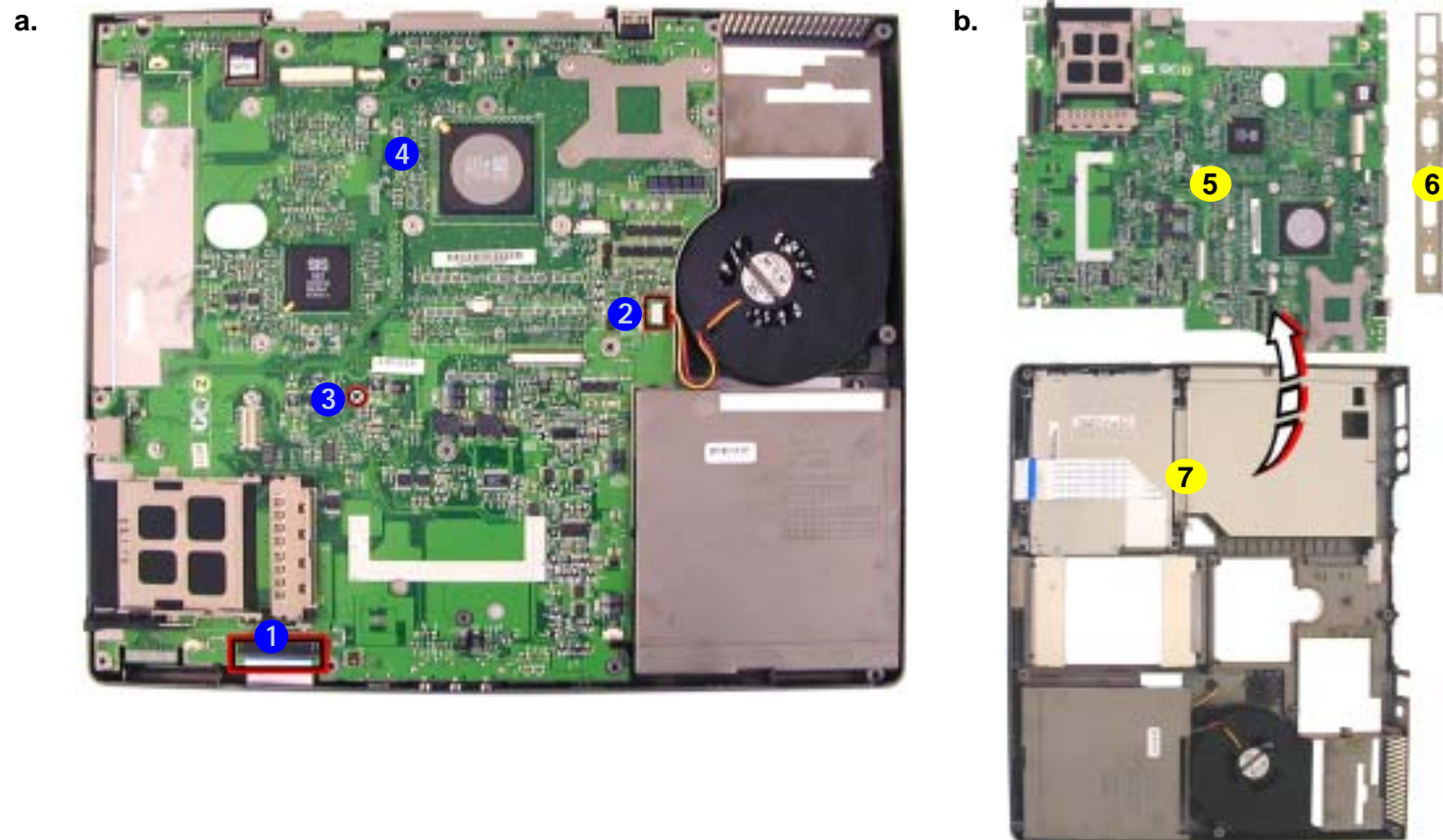

- 5. Mainboard
- 6. Rear Bracket
- 7. Bottom Case
- 2 Screws

Removing the Fan Unit

1. Turn **off** the computer, remove the battery ([page 2 - 8](#)), hard disk ([page 2 - 9](#)), RAM ([page 2 - 10](#)), CD Device ([page 2 - 12](#)), Bluetooth module ([page 2 - 14](#)), Wireless LAN module ([page 2 - 15](#)), CPU ([page 2 - 16](#)), keyboard ([page 2 - 18](#)), keyboard shielding plate ([page 2 - 19](#)), the top case and LCD ([page 2 - 20](#)), speakers ([page 2 - 25](#)) and main-board ([page 2 - 26](#)).
2. Remove screws **1** - **4** (**Figure 20a**) and lift out the fan unit **5** .

a.

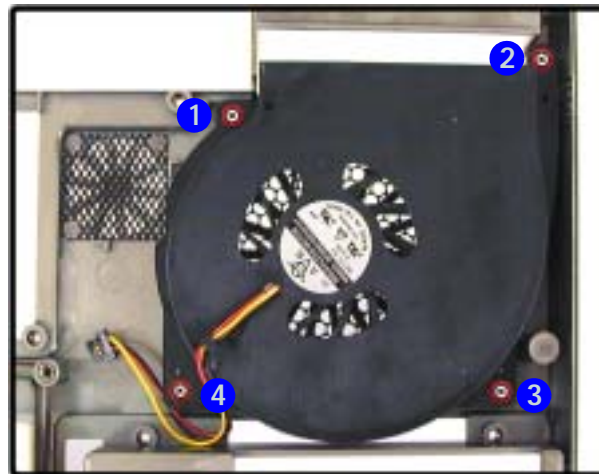

b.

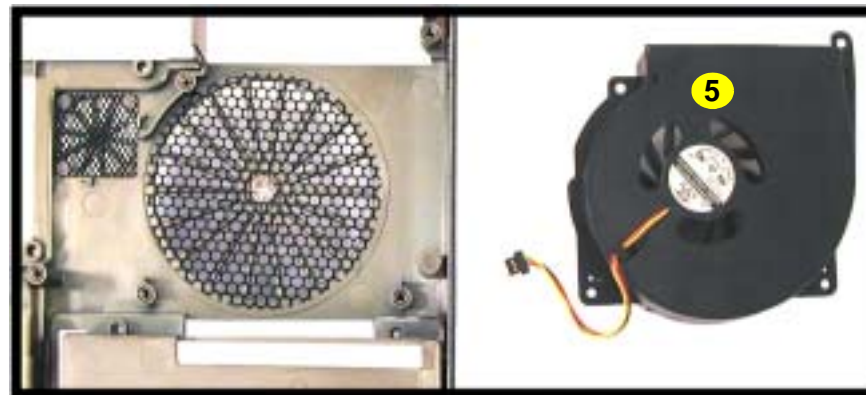

Figure 20
Fan Unit Removal

- a. Remove the screws
- b. Lift out the fan unit.



5. Fan Unit

- 4 Screws

Removing the Floppy Disk Drive Assembly

1. Turn **off** the computer, remove the battery ([page 2 - 8](#)), hard disk ([page 2 - 9](#)), RAM ([page 2 - 10](#)), CD Device ([page 2 - 12](#)), Bluetooth module ([page 2 - 14](#)), Wireless LAN module ([page 2 - 15](#)), CPU ([page 2 - 16](#)), keyboard ([page 2 - 18](#)), keyboard shielding plate ([page 2 - 19](#)), the top case and LCD ([page 2 - 20](#)), speakers ([page 2 - 25](#)) and main-board ([page 2 - 26](#)).
2. Remove screws **1** - **4** (**Figure 21a**) and lift out the floppy disk drive assembly.
3. Remove screws **5** - **8** (**Figure 21c**) and you can then separate the brackets **9** , floppy disk drive unit **10** , and cable **11** .

Figure 21
Floppy Disk Drive Assembly Removal

- a. Remove the screws
- b. Lift out the FDD assembly
- c. Separate the brackets, FDD and cable.

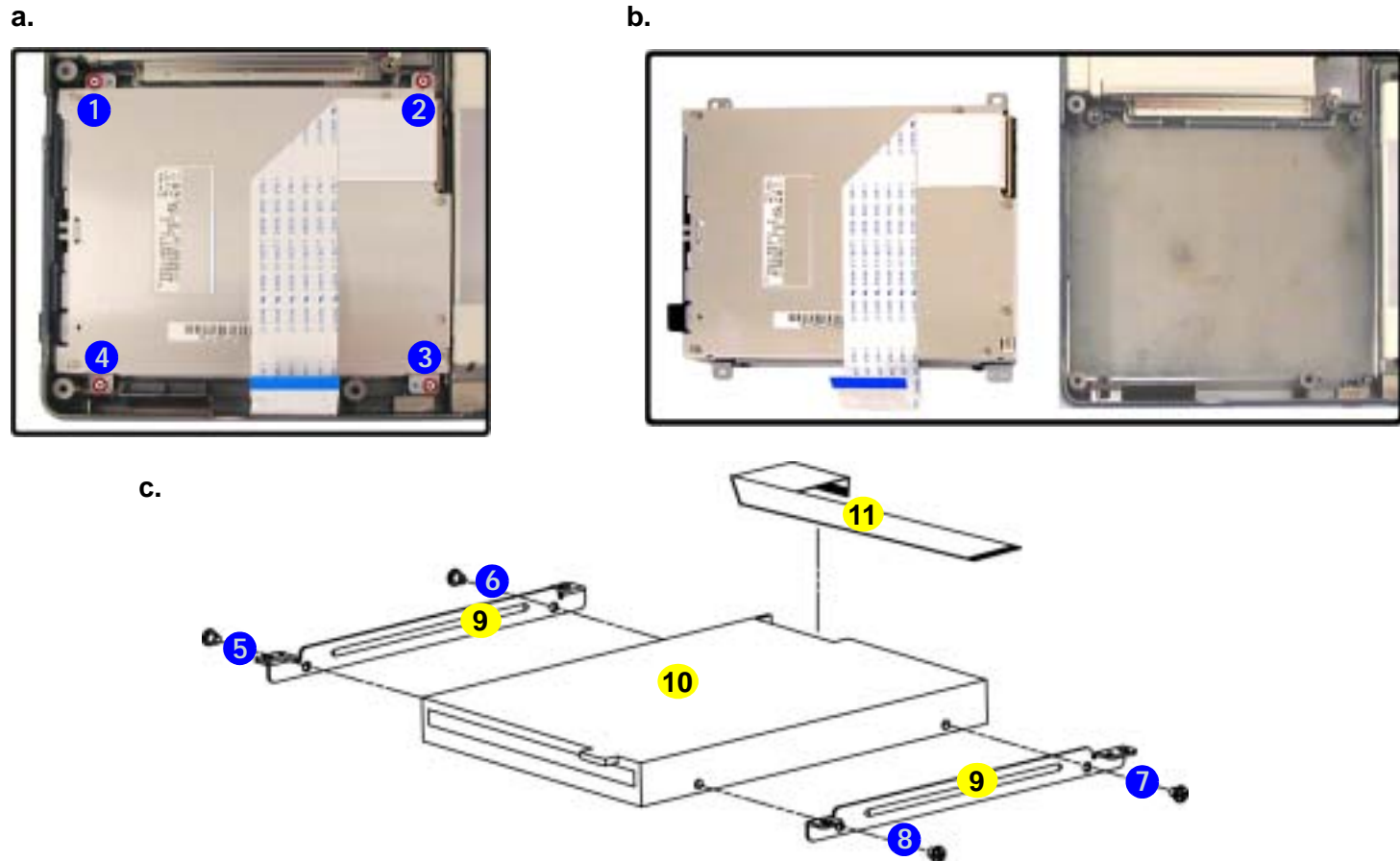

- 9. Brackets
- 10. Floppy Disk Drive
- 11. Cable
- 8 Screws

Removing the PC Card Assembly

1. Turn **off** the computer, remove the battery ([page 2 - 8](#)), hard disk ([page 2 - 9](#)), RAM ([page 2 - 10](#)), CD Device ([page 2 - 12](#)), Bluetooth module ([page 2 - 14](#)), Wireless LAN module ([page 2 - 15](#)), CPU ([page 2 - 16](#)), keyboard ([page 2 - 18](#)), keyboard shielding plate ([page 2 - 19](#)), the top case and LCD ([page 2 - 20](#)), speakers ([page 2 - 25](#)) and mainboard ([page 2 - 26](#)).
2. Remove screws **1** & **2** (**Figure 22a**).
3. Carefully ease (use a small screwdriver) the metal pins which hold the PC Card assembly in place, at points **3** & **4** (**Figure 22b**) off the black plastic unit.
4. Lift off the PC Card assembly **5** (**Figure 22c**) off the mainboard.

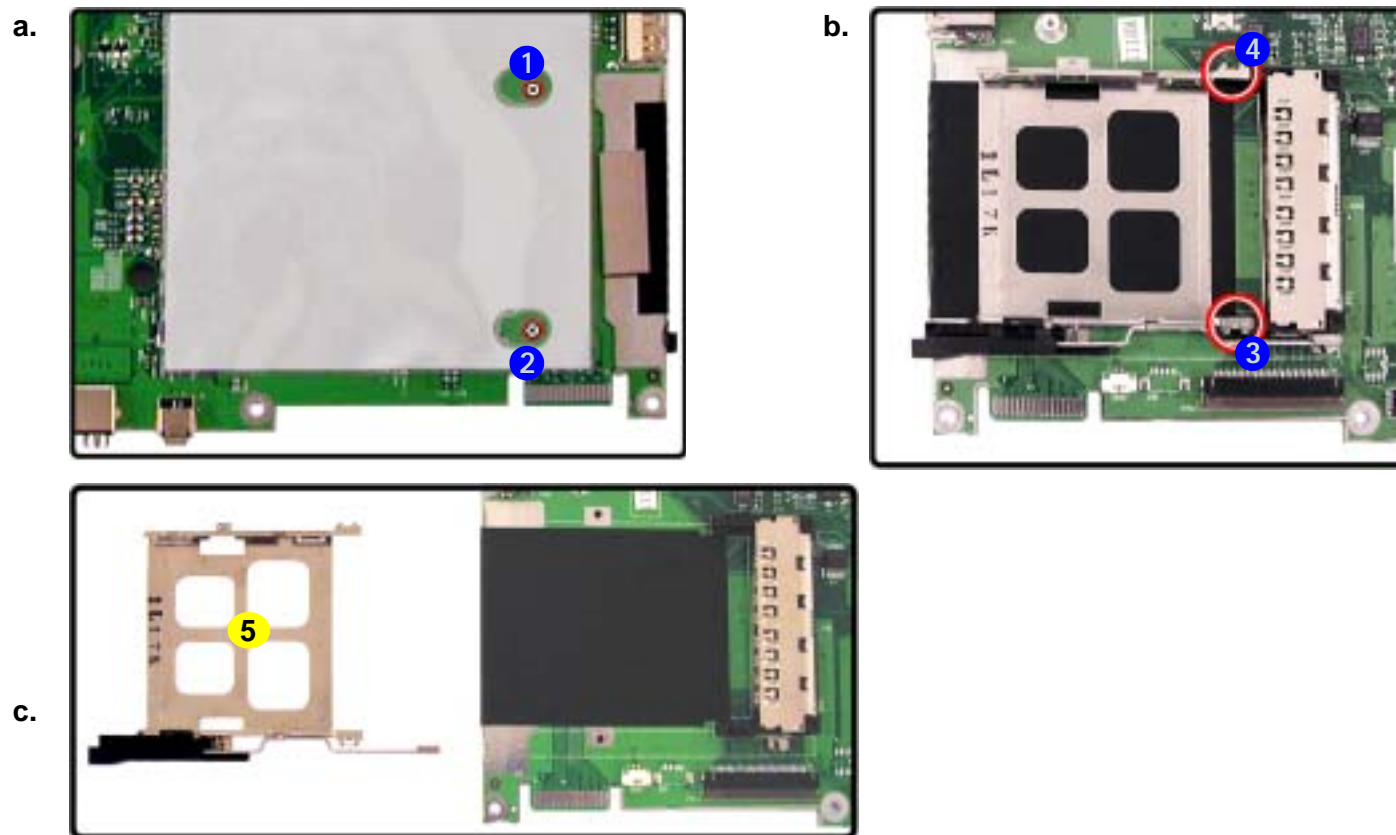

Figure 22
PC Card Assembly Removal

- a. Remove the screws.
- b. Separate the metal pins from the black plastic unit.
- c. Lift the PC Card assembly off the mainboard.



5. PC Card Assembly

- 2 Screws

Removing the LCD Front Panel Module

1. Turn **off** the computer, remove the battery ([page 2 - 8](#)), hard disk ([page 2 - 9](#)), RAM ([page 2 - 10](#)), CD Device ([page 2 - 12](#)), Bluetooth module ([page 2 - 14](#)), Wireless LAN module ([page 2 - 15](#)), CPU ([page 2 - 16](#)), keyboard ([page 2 - 18](#)), keyboard shielding plate ([page 2 - 19](#)), and the top case and LCD ([page 2 - 20](#)).
2. Remove the rubber covers and screws at points **1** - **6** (**Figure 23a**).
3. Run your finger around the middle of the frame to carefully unsnap the LCD front panel module **7** (**Figure 23b**) from the back.

Figure 23
**LCD Front Panel
Module Removal**

- a. Remove the rubber covers and screws.
- b. Unsnap the LCD front panel from the back.

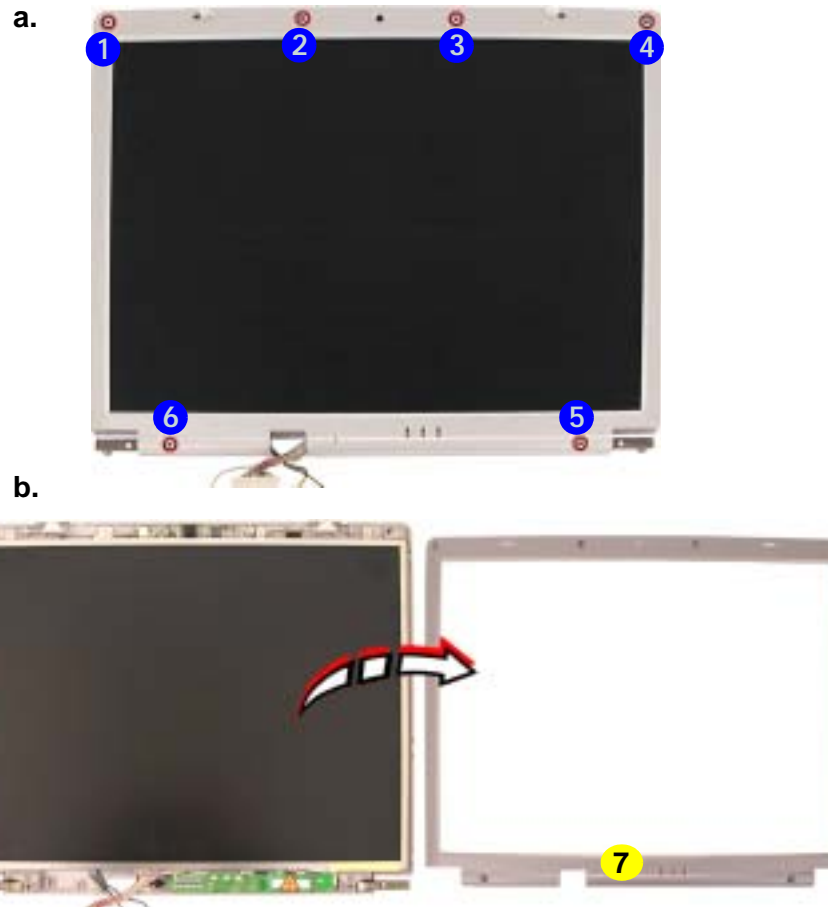

7. LCD Front Panel

- 6 Screws & Rubber Covers

Removing the Inverter

1. Turn **off** the computer, remove the battery ([page 2 - 8](#)), hard disk ([page 2 - 9](#)), RAM ([page 2 - 10](#)), CD Device ([page 2 - 12](#)), Bluetooth module ([page 2 - 14](#)), Wireless LAN module ([page 2 - 15](#)), CPU ([page 2 - 16](#)), keyboard ([page 2 - 18](#)), keyboard shielding plate ([page 2 - 19](#)), the top case and LCD ([page 2 - 20](#)) and LCD front panel ([page 2 - 30](#)).
2. Remove screw **1** (**Figure 24a**).
3. Turn the inverter over and disconnect the cables **2** & **3** (**Figure 24b**).
4. Lift the inverter **4** (**Figure 24c**) off the LCD assembly.

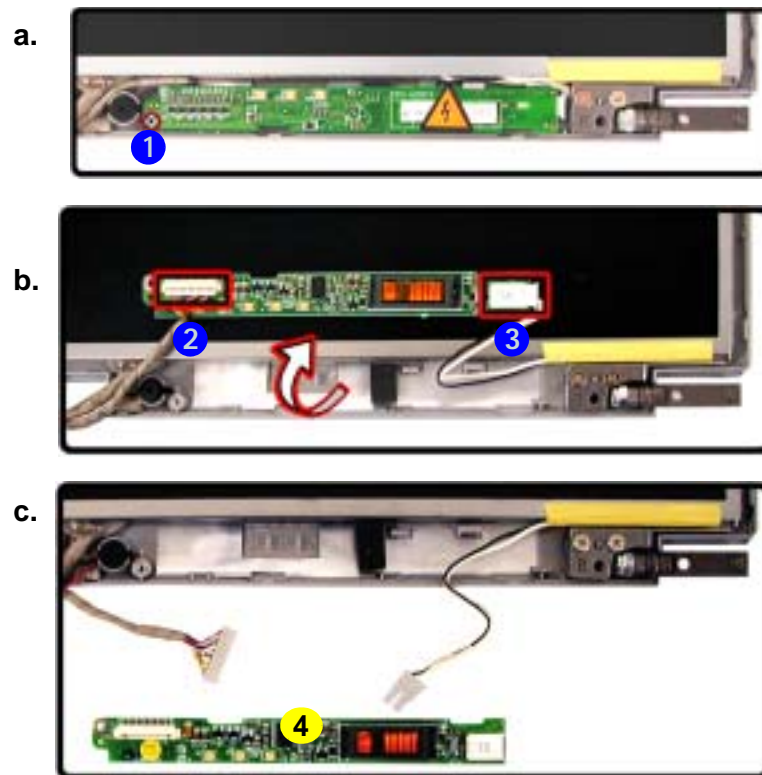
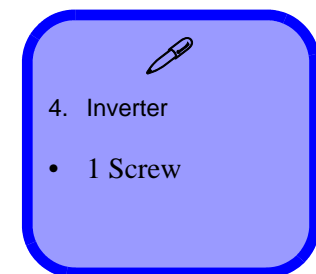

Figure 24
Inverter Removal

- a. Remove the screw.
- b. Turn the inverter over and disconnect the cables.
- c. Lift the inverter off the LCD assembly.



Removing the PC Video Camera Module

1. Turn **off** the computer, remove the battery ([page 2 - 8](#)), hard disk ([page 2 - 9](#)), RAM ([page 2 - 10](#)), CD Device ([page 2 - 12](#)), Bluetooth module ([page 2 - 14](#)), Wireless LAN module ([page 2 - 15](#)), CPU ([page 2 - 16](#)), keyboard ([page 2 - 18](#)), keyboard shielding plate ([page 2 - 19](#)), the top case and LCD ([page 2 - 20](#)) and LCD front panel ([page 2 - 30](#)).
2. Disconnect cable **1** (**Figure 25a**).
3. Lift the PC camera module **2** (**Figure 25b**) off the LCD assembly.
4. If you need to remove the antenna cable, first remove the LCD module ([page 2 - 33](#)), then remove screw **3** and the antenna cable **4** (**Figure 25c**).

Figure 25
PC Camera Module Removal

- a. Disconnect the cable.
- b. Lift the PC Camera off the LCD assembly.
- c. If you need to remove the antenna first remove the LCD module then the screw, and the antenna cable.

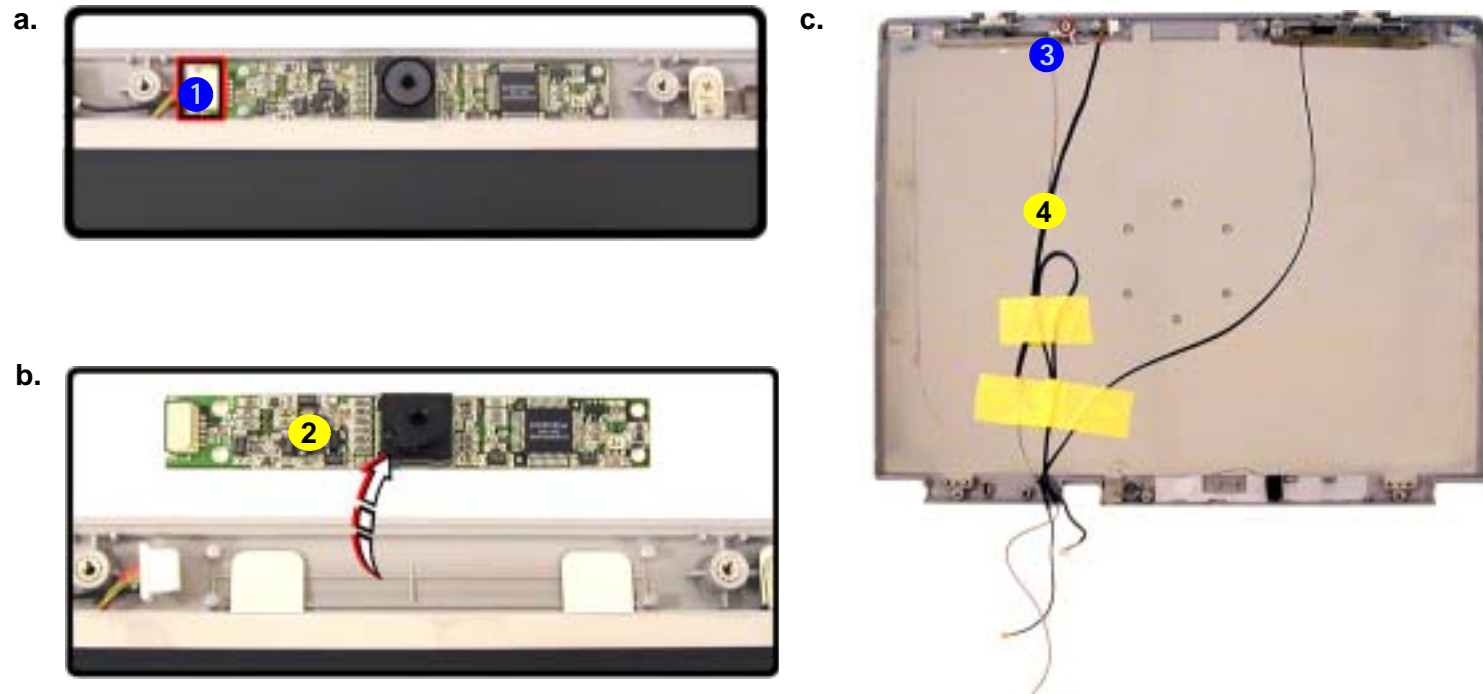

- 2. PC Camera
- 4. Antenna Cable

- 1 Screw

Removing the LCD Module

1. Turn **off** the computer, remove the battery ([page 2 - 8](#)), hard disk ([page 2 - 9](#)), RAM ([page 2 - 10](#)), CD Device ([page 2 - 12](#)), Bluetooth module ([page 2 - 14](#)), Wireless LAN module ([page 2 - 15](#)), CPU ([page 2 - 16](#)), keyboard ([page 2 - 18](#)), keyboard shielding plate ([page 2 - 19](#)), the top case and LCD ([page 2 - 20](#)), LCD front panel ([page 2 - 30](#)) and inverter ([page 2 - 31](#)).
2. Remove screws **1** - **6** (**Figure 26a**).
3. Separate the display back panel **7** (**Figure 26b**), hinges **8** and LCD module assembly.
4. Remove screws **9** - **16** (**Figure 26c**) and separate the LCD module **17** and brackets **18**.

Figure 26
LCD Module Removal

- a. Remove the screws.
- b. Separate the back panel, hinges and LCD module assembly.
- c. Remove the screws and separate the brackets and LCD module.

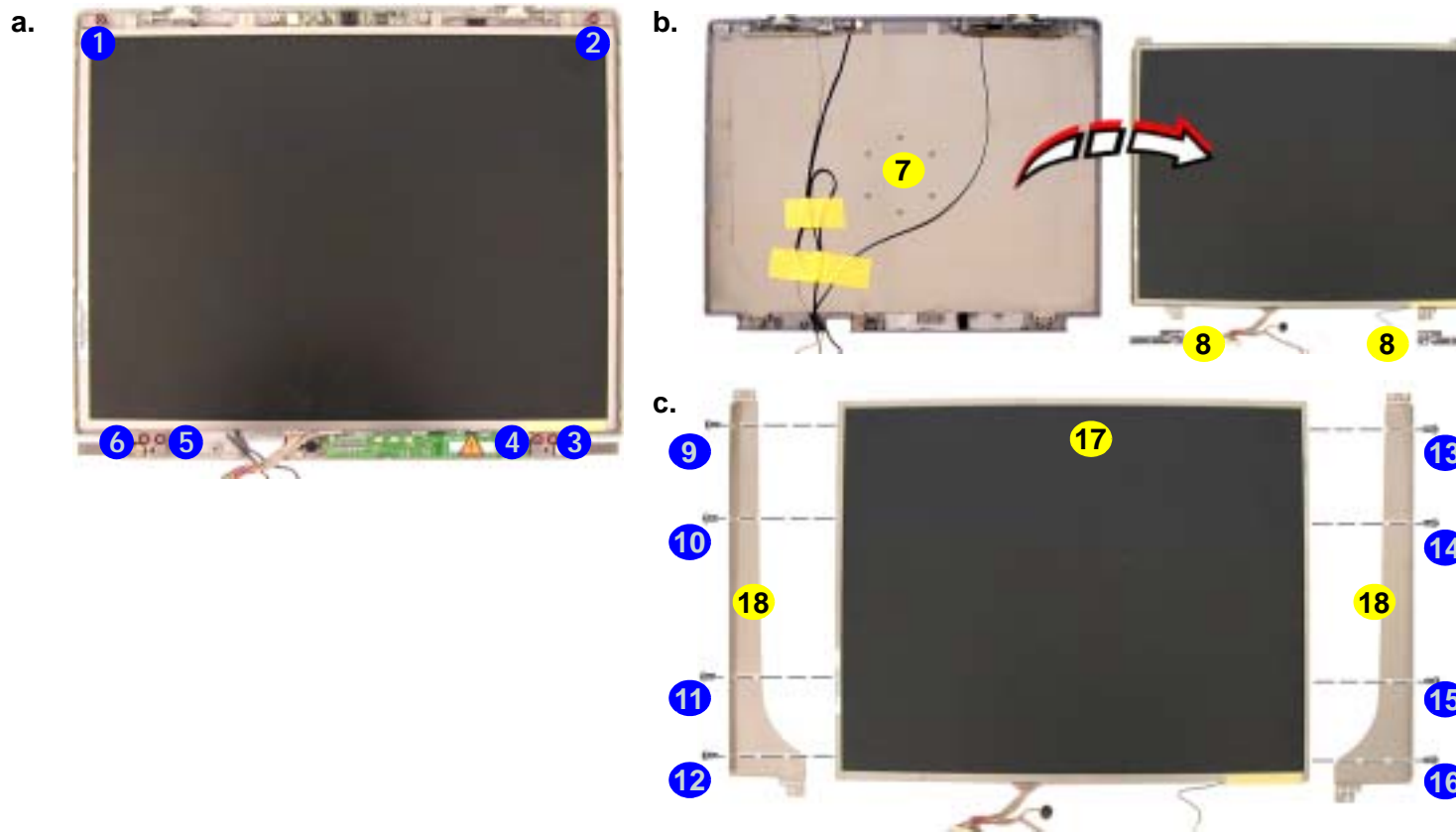

 7. Back Panel
 8. Hinges
 17. LCD module
 18. Brackets
 • 14 Screws

2 - 34 Removing the LCD Module

Appendix A:Part Lists

This appendix breaks down the *D400S/D410S* series notebook's construction into a series of illustrations. The component part numbers are indicated in the tables opposite the drawings.

Note: This section indicates the *manufacturer's* part numbers. Your organization may use a different system, so be sure to cross-check any relevant documentation.

Note: Some assemblies may have parts in common (especially screws). However, the part lists DO NOT indicate the total number of duplicated parts used.

Note: Be sure to check any update notices. The parts shown in these illustrations are appropriate for the system at the time of publication. Over the product life, some parts may be improved or re-configured, resulting in *new* part numbers.

Part List Illustration Location

The following table indicates where to find the appropriate part list illustration.

Table 1 - 1
Part List Illustration
Location

Part	400S	410S
Top	<i>page A - 3</i>	<i>page A - 13</i>
Bottom	<i>page A - 4</i>	<i>page A - 14</i>
LCD 14"	<i>page A - 5</i>	<i>page A - 15</i>
LCD 15"	<i>page A - 6</i>	<i>page A - 16</i>
CD-ROM Drive	<i>page A - 7</i>	<i>page A - 17</i>
CD-RW Drive	<i>page A - 8</i>	<i>page A - 18</i>
Combo Drive	<i>page A - 9</i>	<i>page A - 19</i>
DVD-ROM Drive	<i>page A - 10</i>	<i>page A - 20</i>
Floppy Disk Drive	<i>page A - 11</i>	<i>page A - 21</i>
Hard Disk Drive	<i>page A - 12</i>	<i>page A - 22</i>

Top (400S)

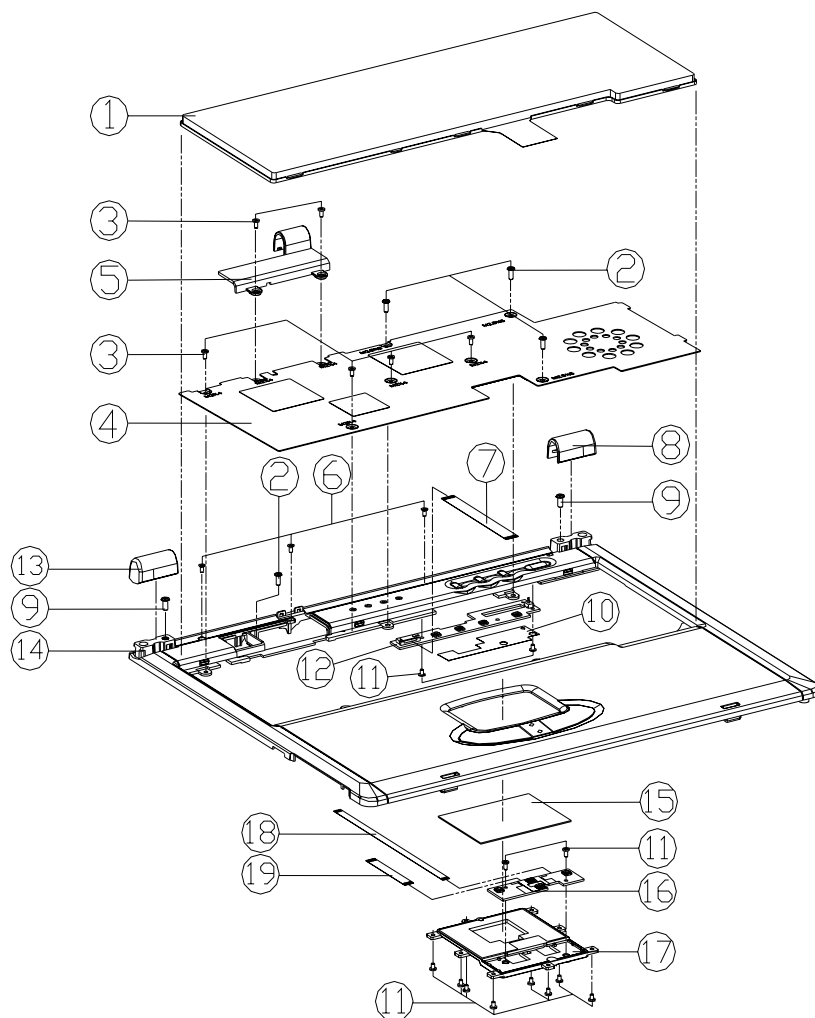

ITEM	PART NAME	PART NO	REMARK
1	KEYBOARD	80-88808-7G0	
2	SCREW M2.5*SL K1 BNI ICT NY	35-B9125-5R0	
3	SCREW M2*4L I BZ ICT NY	35-C6120-4RA	
4	KB SHIELDING	33-D4007-011	
5	CONNECTOR COVER	42-D4008-011	
6	SCREW M2*4L F NI ICT NY	35-21120-4RA	
7	FTC CABLE FOR MAIN BD TO POWER SWITCH BOARD	43-D4000-020	
8	HINGE COVER(R)	42-D400Y-012	
9	SCREW M3*6L K1 NI ICT NY	35-B1130-6RA	
10	MYLAR FOR FUNCTION BOARD	40-D400S-010	
11	SCREW M2*3L K1 NI ICT NY	35-B1120-3RB	
12	SWITCH BOARD	77-D400S-D0X	
13	HINGE COVER (L)	42-D400Y-022	
14	TOP CASE MODULE D400S	39-D4002-013	
15	TOUCHPAD ALPS KKG00F1956A M190S	49-M1902-010	
16	CLICK BOARD	77-D4002-D0X	
17	G/P HOLDER	42-D4002-020	
18	FTC CABLE FOR MAIN BD TO CLICK BD (26MM)	43-D4000-030	
19	FTC CABLE FOR CLICK TO TOUCH PAD (35MM)	43-D4000-040	

Figure 1
Top (400S)

A.Part Lists

Bottom (400S)

Figure 2
Bottom (400S)

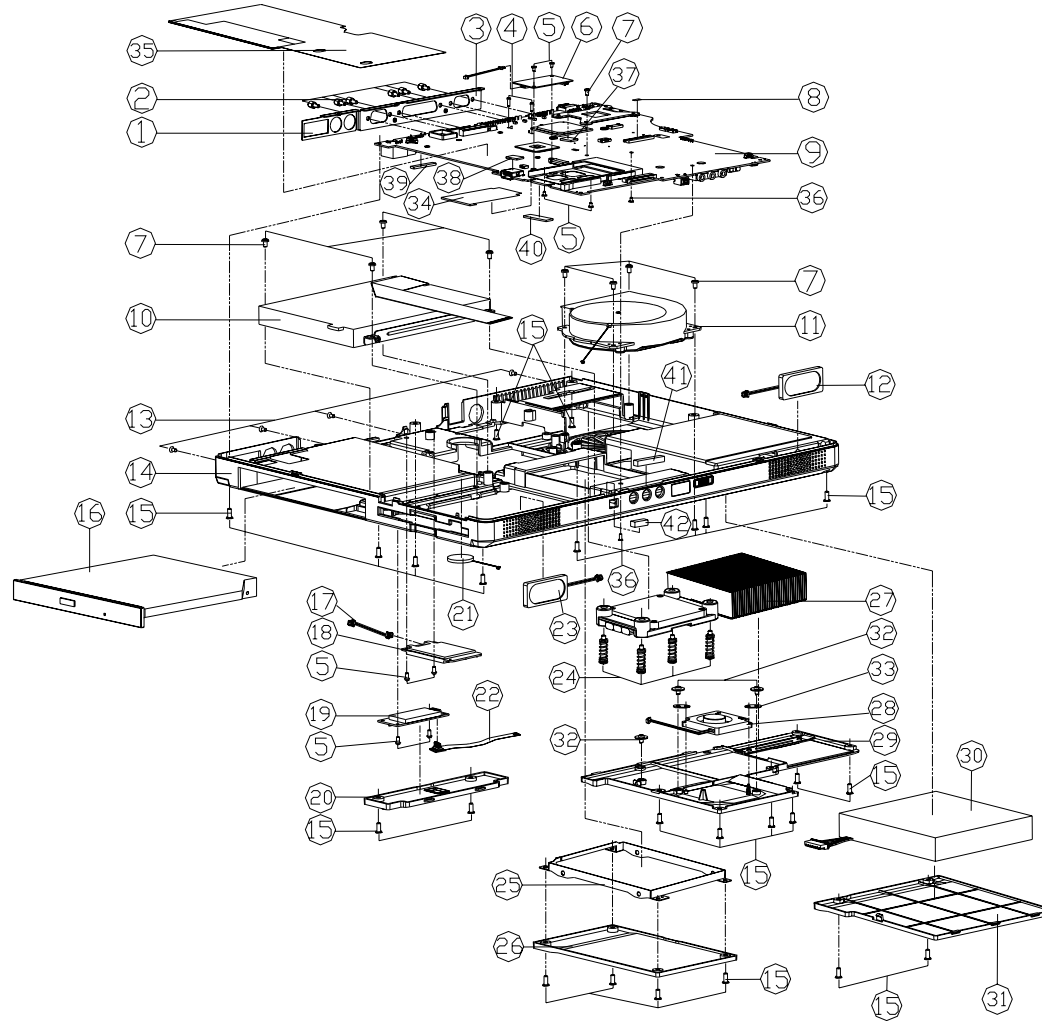

ITEM	PART NAME	PART NO	REMARK
1	I/O BRACKET	33-D400S-010	
2	HEX STUD(SUM22 NI-PL) 1MM	34-07009-011-A	
3	CABLE FOR MDC179MMJAE F1-SESACES 05006	43-D400J-011	
4	SCREW M2*6L P BZ ICT NY	35-06120-6RA	
5	SCREW M2*3L KI NI ICT NY	35-B1120-3RA	
6	MDC MODEM+TEL.CABLE MODULE	76-32200-100	
7	SCREW M2.5*5L KI BNI ICT NY	35-B9125-5R0	
8	MYLAR(SH025D) FOR BSV LCR(SAMSUNG)	40-00150-150	
9	MAIN BOARD	77-D4000-DOX	
10	FDD ASS'Y(OPTION)	79-D400J-010	Reference Assy. No (99-D400S-360)
11	D400S FAN MODULE	31-D400S-101	
12	SPEAKER 85mm IW 8 FYH-35N16B RIGHT	23-32510-801	
13	SCREW M2*4L F NI ICT NY	35-21120-4RA	
14	BOTTOM CASE MODULE	39-D4003-012	
15	SCREW M2.5*6L K BZ ICT	35-82125-6R0	
16	CD-ROM OS(SICR-242) ASS'Y D400S	79-D400Z-000	Reference Assy. No (99-D400S-370)
16	DVD-ROM OS(SICR-082) ASS'Y D400S	79-D400V-000	Reference Assy. No (99-D400S-380)
16	CD-RW TRACKCD-V224E-AB2 ASS'Y D400S	79-D400W-000	Reference Assy. No (99-D400S-390)
16	COMBO OS(SICR-161) ASS'Y D400S	79-D400X-000	Reference Assy. No (99-D400S-100)
17	WIRE CABLE FOR MAIN BD TO WLAN USB BD	43-D4000-070	
18	WLAN 802.11 b USB INTERFACE USB-300	88-D4020-380	
19	BLUETOOTH MODULE V11 USB INTERFACE(USD)	88-18250-370	
20	BLUETOOTH COVER MODULE	42-D400B-101	
21	BAT 20M 2V 230MH V/CABLE 50MM (2002/0730P)	23-22015-P2B	
22	PC CABLE FOR MAIN BD TO BLUETOOTH BD	43-D4000-011	
23	SPEAKER 25mm IW 8 FYH-35N16B LEFT	23-32510-801	
24	SCREW M2.5*4.5P155 dl-35 L-155 S-25	35-49025-155	
25	HDD BRACKET	33-D4001-010	
26	HDD COVER	42-D4001-011	
27	D400S HEAT SINK MODULE	31-D400N-100	
28	FAN 35*35*6T	23-A3510-461	
29	CPU COVER MODULE	42-D400S-101	
30	Smart batt. 452P 14.8V 4400MAH(SMP)	87-D408S-4D5	
30	Smart batt. 452P 14.8V 4400MAH(GLD)	87-D408S-4E5	
31	BATTERY COVER MODULE	42-D400M-101	
32	SCREW M2.5*2.5L B NI ICT V/WAS NY	35-41025-2R5	
33	FAN BRACKET	33-D400S-060	
34	PCMCIA MYLAR MYLAR 320	40-32004-000	
35	EMI SHIELDING FOR M/B	47-D400S-020	
36	SCREW M2*4L I BZ ICT NY	35-C6120-4RA	
37	GASKET FOR USB(W10mm H2mm L17mm)	47-00190-174	
38	GASKET FOR USB CONNECTOR(W10mm H2mm L19mm)	47-00190-157	
39	GASKET FOR PS2 AND S-VIDEO(W5mm H3mm L35mm)	47-00190-353	
40	GASKET FOR LEFT SIDE OF M/B(W10mm H3mm L35mm)	47-00190-308	
41	GASKET FOR AUDIO(W10mm H6.5mm L35mm)	47-00190-354	
42	GASKET FOR 1394(W5mm H5.5mm L13mm)	47-00190-133	

LCD 14" (400S)

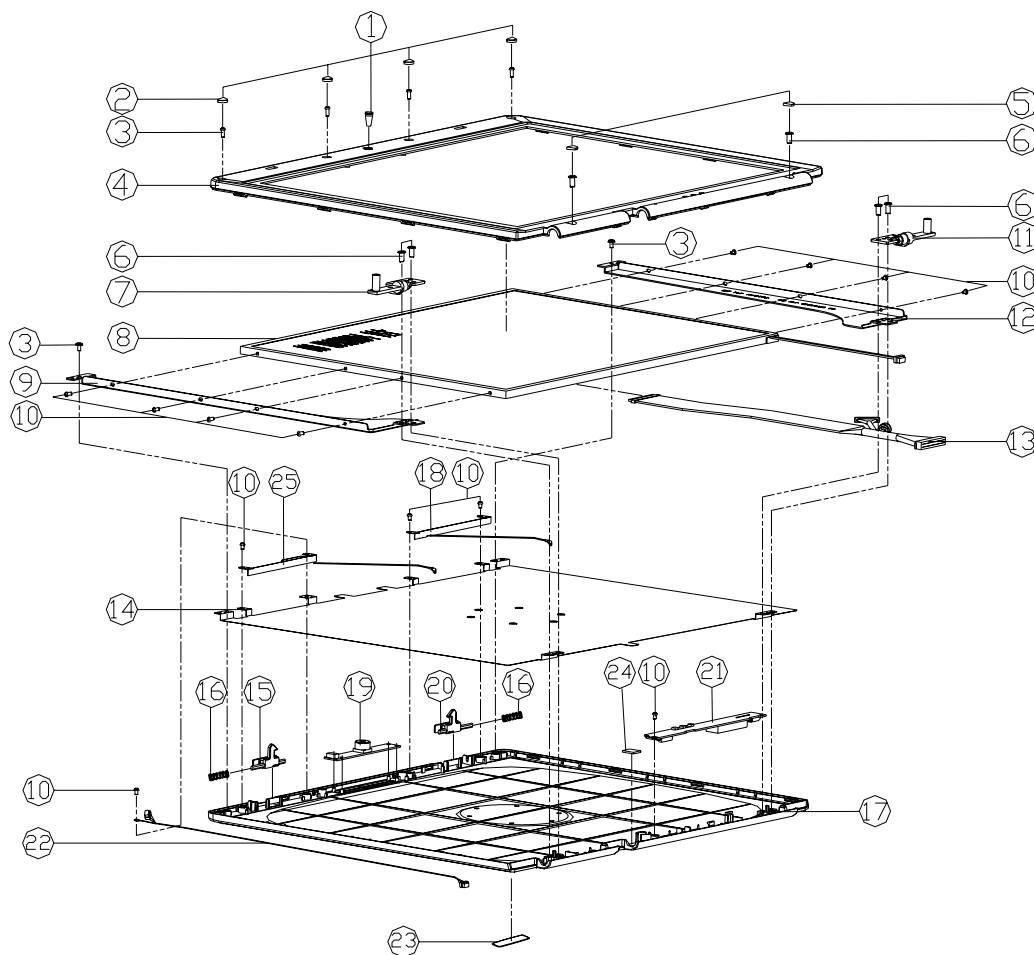

Figure 3
LCD 14" (400S)

ITEM	PART NAME	PART NO	REMARK
1	RUBBER FOR VIDEO CAMERA	47-D400P-010	
2	RUBBER FOR LCD (TOP)	47-56P32-010	
3	SCREW M2*4L I BZ ICT	35-C6120-4R0	
4	DISPLAY FRONT PANEL 14.1" MODULE	39-D4001-100	
5	DISPLAY RUBBER PAD (DOWN)	47-D4001-020	
6	SCREW M3*6L K1 NI ICT NY	35-B1130-6RA	
7	HINGE (L)	33-D400Y-020	
8	LCD T AU B141XN04 V.1 14.1" XGA	50-J2287-G04	
8	LCD T BM ITX77-E53-029 14.1" XGA	50-J2287-E01	
9	LCD BRACKET (L) FOR AU 14.1" LCD	33-D4001-120	
9	LCD BRACKET (L) FOR 14.1" LCD	33-D4001-020	
10	SCREW M2*3L K1 NI ICT NY	35-B1120-3RB	
11	HINGE (R)	33-D400Y-010	
12	LCD BRACKET (R) FOR AU 14.1" LCD	33-D4001-110	
12	LCD BRACKET (R) FOR 14.1" LCD	33-D4001-010	
13	WIRE CABLE FOR 14" LCD XGA AU	43-D4001-021	
14	LCD SHIELDING	33-D4001-050	
15	LCD HOOK(L)	42-D4001-020	
16	SPRING FOR HOOK(φ3.7*15*0.3φ)	38-21P30-011	
17	DISPLAY BACK PANEL MODULE D400S	39-D4001-200	
17	DISPLAY BACK PANEL MODULE M400S	39-M4001-200	
18	WIRELESS ANTENNA PIFA 2.4G L=430mm D400S	23-742R4-004	
19	VIDEO CAMERA CMOS130, 300K Pixels Resolu	88-D40C0-410	OPTION
20	LCD HOOK(R)	42-D4001-010	
21	INVERTER BOARD	77-4200R-D02-1	
22	WIRE CABLE MAIN BD TO CCD MODULE	43-D4000-060	OPTION
23	NAME PLATE "NOTEBOOK"	45-42001-010	
24	GASKET FOR Y CABLE(φ10mm H20mm L150mm)	47-00190-158	
25	ANTENNA BLUETOOTH PIFA 2.4G L=540mm	23-742R4-005	

A.Part Lists

LCD 15" (400S)

Figure 4
LCD 15" (400S)

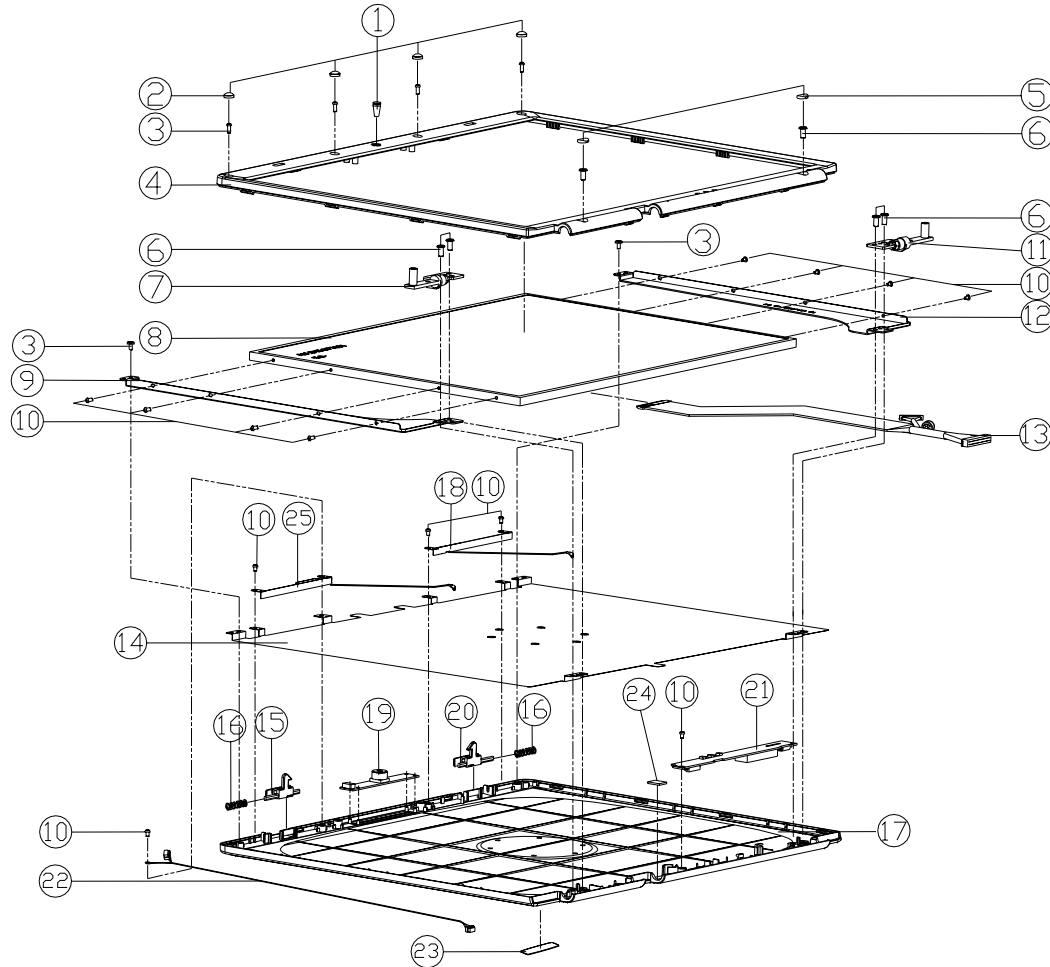

ITEM	PART NAME	PART NO	REMARK
1	RUBBER FOR VIDEO CAMERA	47-D400P-010	
2	RUBBER FOR LCD (TOP)	47-56P32-010	
3	SCREW M2*4L I BZ ICT	35-C6120-4R0	
4	DISPLAY FRONT PANEL 15" MODULE	39-D4001-110	
5	DISPLAY RUBBER PAD (DOWN)	47-D4001-020	
6	SCREW M3*6L KI NI ICT NY	35-B1130-6RA	
7	HINGE (L)	33-D400Y-020	
8	LCD 15.0" TFT AU B150P01 1400*1050 SXGA+	50-L5259-U10	
8	LCD 15.0" IBM TFT 0EM95C-02 SXGA+ 41mm	50-L3241-E00	
9	LCD BRACKET (L) FOR AU 15.1" LCD	33-D4001-140	
9	LCD BRACKET (L) FOR IBM 15.1" LCD	33-D4001-240	
10	SCREW M2*3L KI NI ICT NY	35-B1120-3RB	
11	HINGE (R)	33-D400Y-010	
12	LCD BRACKET (R) FOR AU 15.1" LCD	33-D4001-130	
12	LCD BRACKET (R) FOR IBM 15.1" LCD	33-D4001-230	
13	WIRE CABLE FOR 15" LCD SXGA+ AU	43-D4001-121	
13	WIRE CABLE FOR 15" LCD SXGA+ IDT	43-D4001-111	
14	LCD SHIELDING	33-D4001-050	
15	LCD HOOK(L)	42-D4001-020	
16	SPRING FOR HOOK(φ3.7*15*0.3d)	38-21P30-011	
17	DISPLAY BACK PANEL MODULE D400S	39-D4001-200	
17	DISPLAY BACK PANEL MODULE M400S	39-M4001-200	
18	WIRELESS ANTENNA PIFA 24G L=430mm D400S	23-742R4-004	
19	VIDEO CAMERA CM3130, 300K Pixels Resolu	88-D400C-410	OPTION
20	LCD HOOK(R)	42-D4001-010	
21	INVERTER BOARD	77-4200R-D02-1	
22	WIRE CABLE MAIN BD TO CCD MODULE	43-D4000-060	OPTION
23	NAME PLATE "NOTEBOOK"	45-42001-010	
24	GASKET FOR Y CABLE(φ10mm H2mm L115mm)	47-00190-158	
25	ANTENNA BLUETOOTH PIFA 24G L=540mm	23-742R4-005	

CD-ROM Drive (400S)

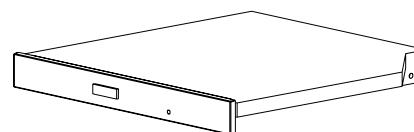
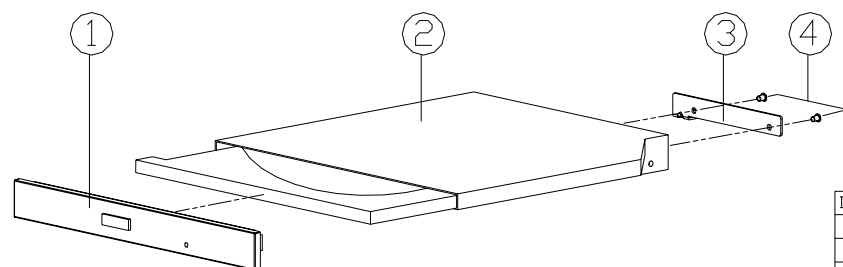

Figure 5
CD-ROM Drive
(400S)

ITEM	PART NAME	PART NO	REMARK
1	CD-ROM BEZEL MODULE OSI	42-D400Z-100	
1	CD-ROM BEZEL MODULE TEAC	42-D400Z-300	
2	CD-ROM 5 1/4" 24X CAB SLIM OSISCR-242)	85-607□X-C00	
2	CD-ROM 5 1/4" 24X CD-224E-C20 12.7mm TEAC	85-607□X-709	
3	CDROM LOCK BRACKET	33-D400Z-010	
4	SCREW M2*3L K1 NI ICT NY	35-B1120-3RB	

A.Part Lists

CD-RW Drive (400S)

Figure 6
CD-RW Drive
(400S)

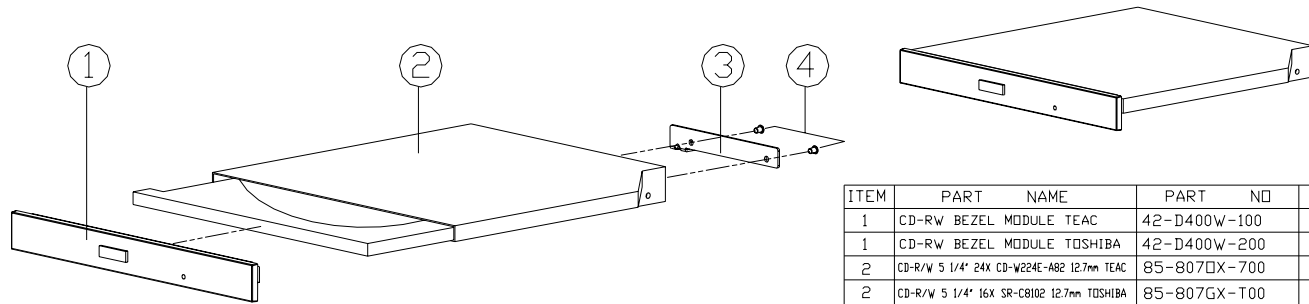

ITEM	PART NAME	PART NO	REMARK
1	CD-RW BEZEL MODULE TEAC	42-D400W-100	
1	CD-RW BEZEL MODULE TOSHIBA	42-D400W-200	
2	CD-R/W 5 1/4" 24X CD-W224E-A82 12.7mm TEAC	85-807DX-700	
2	CD-R/W 5 1/4" 16X SR-C8102 12.7mm TOSHIBA	85-807GX-T00	
3	CDROM LOCK BRACKET	33-D400Z-010	
4	SCREW M2*3L KI NI ICT NY	35-B1120-3RB	

Combo Drive (400S)

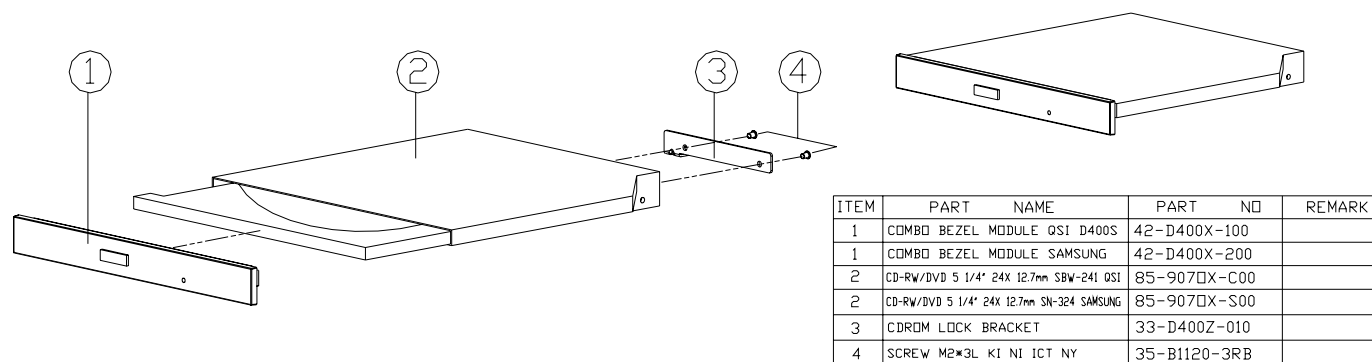
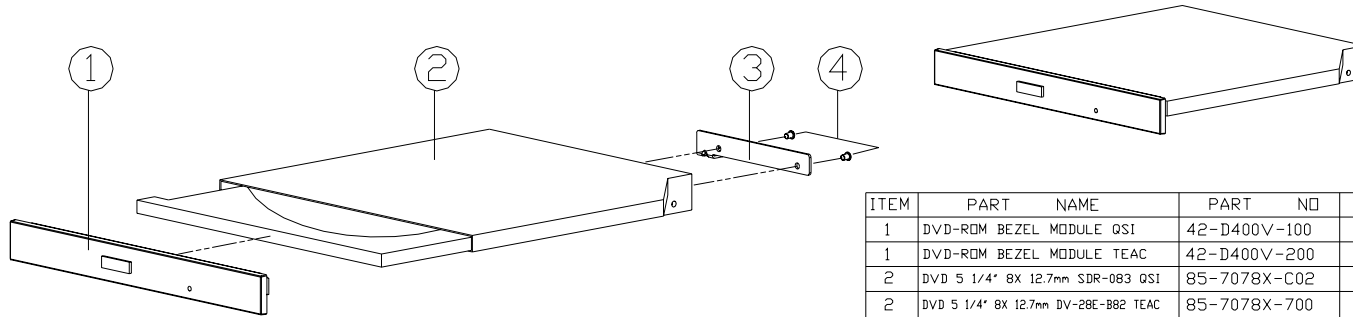

Figure 7
Combo Drive
(400S)

A.Part Lists

DVD-ROM Drive (400S)

Figure 8
DVD-ROM Drive
(400S)



ITEM	PART NAME	PART NO	REMARK
1	DVD-ROM BEZEL MODULE QSI	42-D400V-100	
1	DVD-ROM BEZEL MODULE TEAC	42-D400V-200	
2	DVD 5 1/4" 8X 12.7mm SDR-083 QSI	85-7078X-C02	
2	DVD 5 1/4" 8X 12.7mm DV-28E-BB2 TEAC	85-7078X-700	
3	CDROM LOCK BRACKET	33-D400Z-010	
4	SCREW M2*3L KI NI ICT NY	35-B1120-3RB	

Floppy Disk Drive (400S)

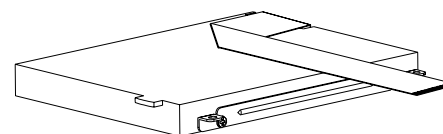
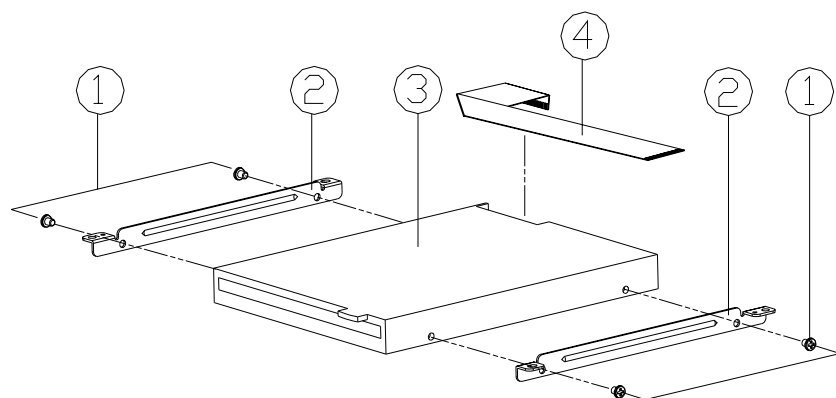

Figure 9
Floppy Disk Drive
(400S)

ITEM	PART NAME	PART NO	REMARK
1	SCREW M2.5*3L KI BK/D.NY	35-B4125-3RA	
2	FDD BRACKET	33-D400J-010	
3	FDD 3.5" 1.44MB 12.7mm (YD-702J-6637J)	85-11700-Y01-01	
4	FFC CABLE FOR MAIN BD TO FDD 180MM	43-D4000-050	

A.Part Lists

Hard Disk Drive (400S)

Figure 10
HDD Drive (400S)

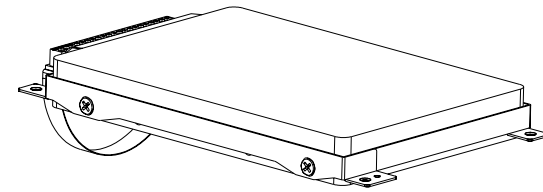
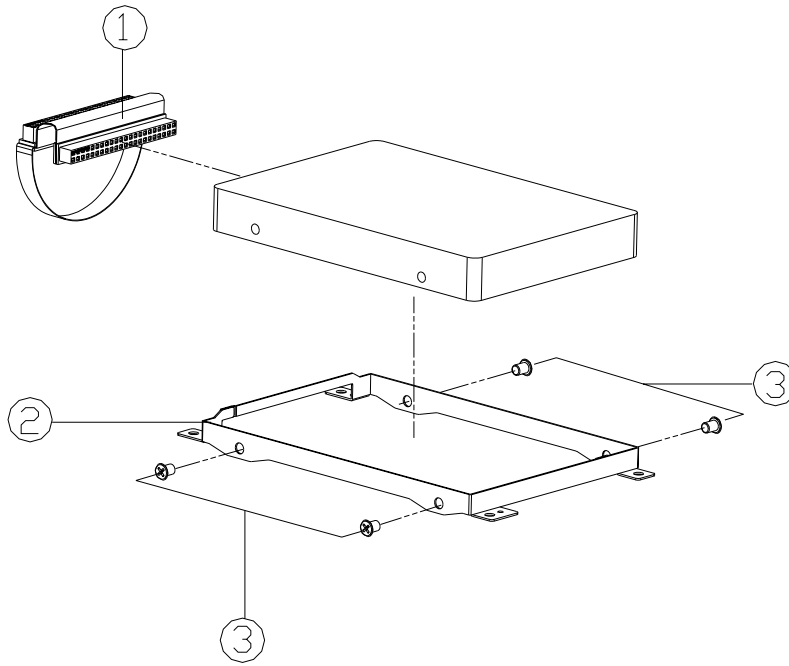

ITEM	PART NAME	PART NO	REMARK
1	FPC CABLE FOR HD TO MAIN BD, 30MM,8880	43-88800-010	
2	HDD BRACKET	77-22004-D03A	
3	SCREW M3*4L KI BZ ICT NY	35-B6130-4RB	

Top (410S)

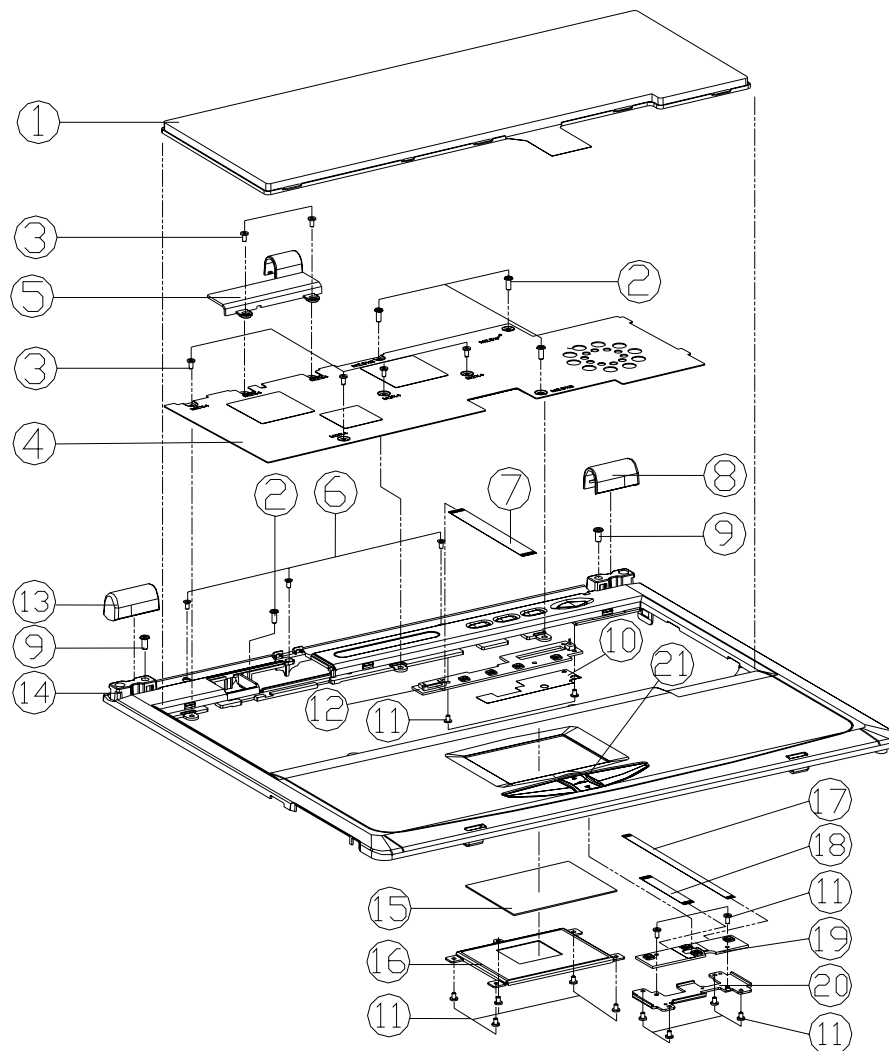

ITEM	PART NAME	PART NO	REMARK
1	KEYBOARD	80-88808-7G0	
2	SCREW M2.5*5L KI BNI ICT NY	35-B9125-5R0	
3	SCREW M2*4L I BZ ICT NY	35-C6120-4RA	
4	KB SHIELDING	33-D4007-011	
5	CONNECTOR COVER FOR D410S	42-D4108-011	
6	SCREW M2*4L F NI ICT NY	35-21120-4RA	
7	FFC CABLE FOR MAIN 80 TO POWER SWITCH BOARD	43-D4000-020	
8	HINGE COVER(R)	42-D400Y-012	
9	SCREW M3*5L KI NI ICT NY	35-B1130-5RA	
10	MYLAR FOR FUNCTION BOARD	40-D400S-011	
11	SCREW M2*3L KI NI ICT NY	35-B1120-3RB	
12	SWITCH BOARD	77-D400S-DOX	
13	HINGE COVER (L)	42-D400Y-022	
14	TOP CASE MODULE D410S	39-D4102-011	
15	TOUCHPAD ALPS KKGDPT956A M190S	49-M1902-010	
16	TOUCH PAD BRACKET	33-D4102-011	
17	FFC CABLE FOR MAIN 80 TO CLICK 80 126MM	43-D4000-030	
18	FFC CABLE FOR CLICK TO TOUCH PAD 43MM	43-D4000-040	
19	CLICK BOARD	77-D4002-DOX	
20	CLICK PCB BRACKET	33-D410S-010	
21	SCROLL KNOB	42-D4102-021	

Figure 11
Top (410S)

A.Part Lists

Bottom (410S)

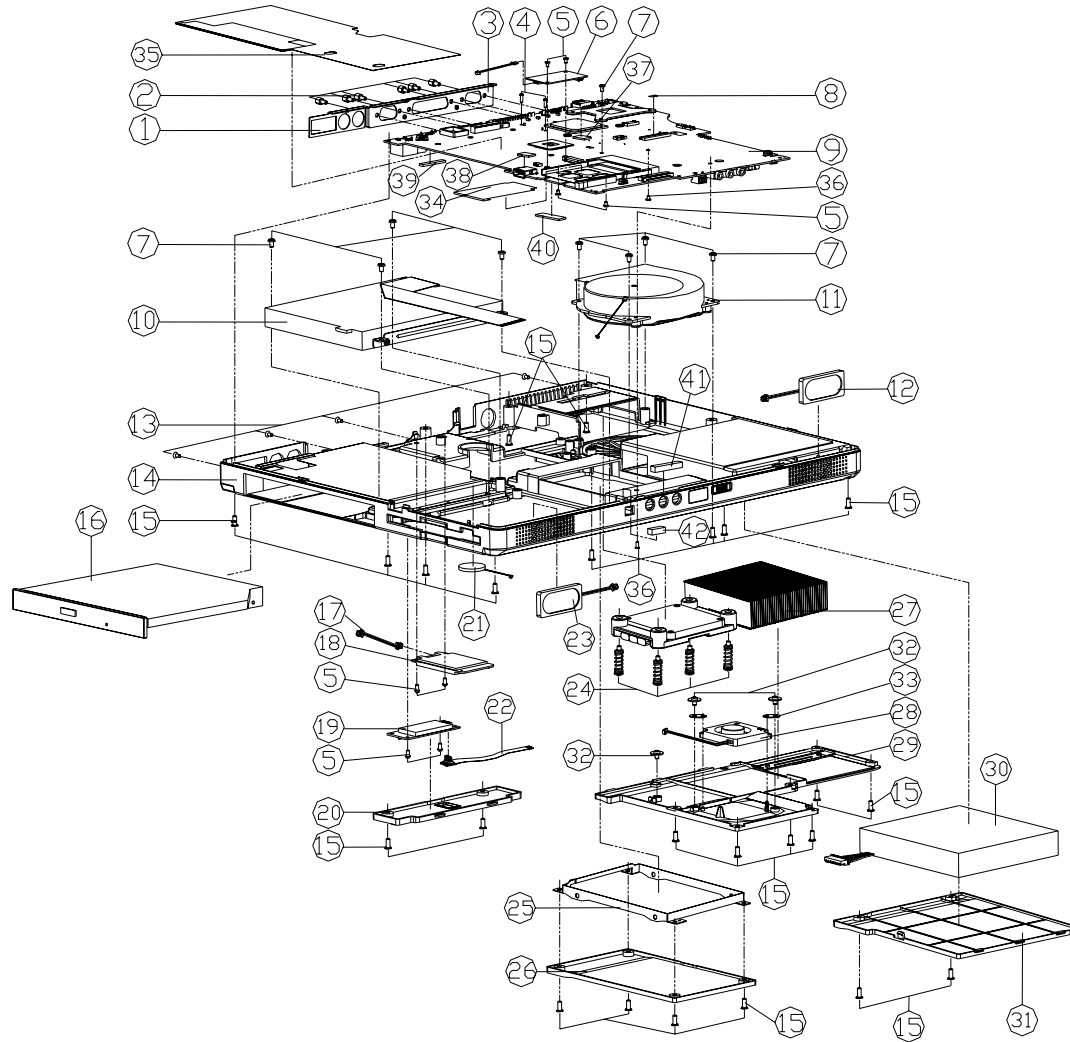

Figure 12
Bottom (410S)

ITEM	PART NAME	PART NO	REMARK
1	I/O BRACKET	33-D400S-010	
2	HEX STUD(SUM22 NI-PL) 11MM	34-07009-011-A	
3	CABLE FOR MDC175MM, IAC FI-SESACES B5206	43-D400U-011	
4	SCREW M2*6L P BZ ICT NY	35-06120-6RA	
5	SCREW M2*3L KI NI ICT NY	35-B1120-3RA	
6	MDC MODEM+TEL.CABLE MODULE	76-32200-100	
7	SCREW M2.5*5L KI BNI ICT NY	35-B9125-5R0	
8	MYLAR15*8*0.25(I) FDR BSV LCD(SANSUNG)	40-00150-150	
9	MAIN BOARD	77-D4000-DOX	
10	FDD ASS'Y(OPTION)	79-D400J-010	Reference Ass'y Info (59-D400S-165)
11	D400S FAN MODULE	31-D400S-101	
12	SPEAKER 85mm IV 8 FYN-25N16B RIGHT	23-32510-801	
13	SCREW M2*4L F NI ICT NY	35-21120-4RA	
14	BOTTOM CASE MODULE FOR D410S	39-D4103-011	
15	SCREW M2.5*6L K BZ ICT	35-82125-6R0	
16	CD-ROM DS1(SCR-242) ASS'Y D410S	79-D410Z-000	Reference Ass'y Info (59-D410S-170)
16	DVD-ROM DS1(SDR-083) ASS'Y D410S	79-D410V-000	Reference Ass'y Info (59-D410S-180)
16	CD-RW TEAC(CD-V224E-AB2) ASS'Y D410S	79-D410W-000	Reference Ass'y Info (59-D410S-190)
16	COMBO DS1(SBW-161) ASS'Y D410S	79-D410X-000	Reference Ass'y Info (59-D410S-100)
17	WIRE CABLE FOR MAIN BD TO WLAN USB BD	43-D4000-070	
18	WLAN 802.11 b USB INTERFACE USB-300	88-D4020-380	
19	BLUETOOTH MODULE VII USB INTERFACE(SD)	88-18250-370	
20	BLUETOOTH COVER MODULE D410S	42-D410B-101	
21	BAT 2000 mAh 230mAh V/CABLE 500M CR2032/0730HP	23-22015-P2B	
22	IPC CABLE FOR MAIN BD TO BLUETOOTH BD 0400	43-D4000-011	
23	SPEAKER 25mm IV 8 FYN-25N16B LEFT	23-32510-801	
24	SCREW M2.5*4.5P*15.5 dl=35 L=155 S=25	35-49025-155	
25	HDD BRACKET	33-D4001-010	
26	HDD COVER FOR D410S	42-D4101-011	
27	D400S HEAT SINK MODULE	31-D400N-100	
28	FAN 35*35*6T	23-A3510-461	
29	CPU COVER MODULE D410S	42-D410S-101	
30	Smart batt 4SRP 14.8V 4400MAH(SMP)	87-D408S-4D5	
30	Smart batt 4SRP 14.8V 4400MAH(LGD)	87-D408S-4E5	
31	BATTERY COVER MODULE D410S	42-D410M-101	
32	SCREW M2.5*2.5L B NI ICT W/WAS NY	35-41025-2R5	
33	FAN BRACKET	33-D400S-060	
34	PCMCIA MYLAR MYLAR 320	40-32004-000	
35	EMI SHIELDING FOR M/B	47-D400S-020	
36	SCREW M2*4L I BZ ICT NY	35-C6120-4RA	
37	GASKET FOR USB(V10mm H2mm L17mm)	47-00190-174	
38	GASKET FOR USB CONNECTOR(V10mm H4mm L15mm)	47-00190-157	
39	GASKET FOR PSE AND S-VIDEO(V5mm H3mm L13mm)	47-00190-353	
40	GASKET FOR LEFT SIDE OF M/B(V10mm H3mm L13mm)	47-00190-30B	
41	GASKET FOR AUDIO(V10mm H6.5mm L13.5mm)	47-00190-354	
42	GASKET FOR 1394(V5mm H5.5mm L13mm)	47-00190-133	

LCD 14" (410S)

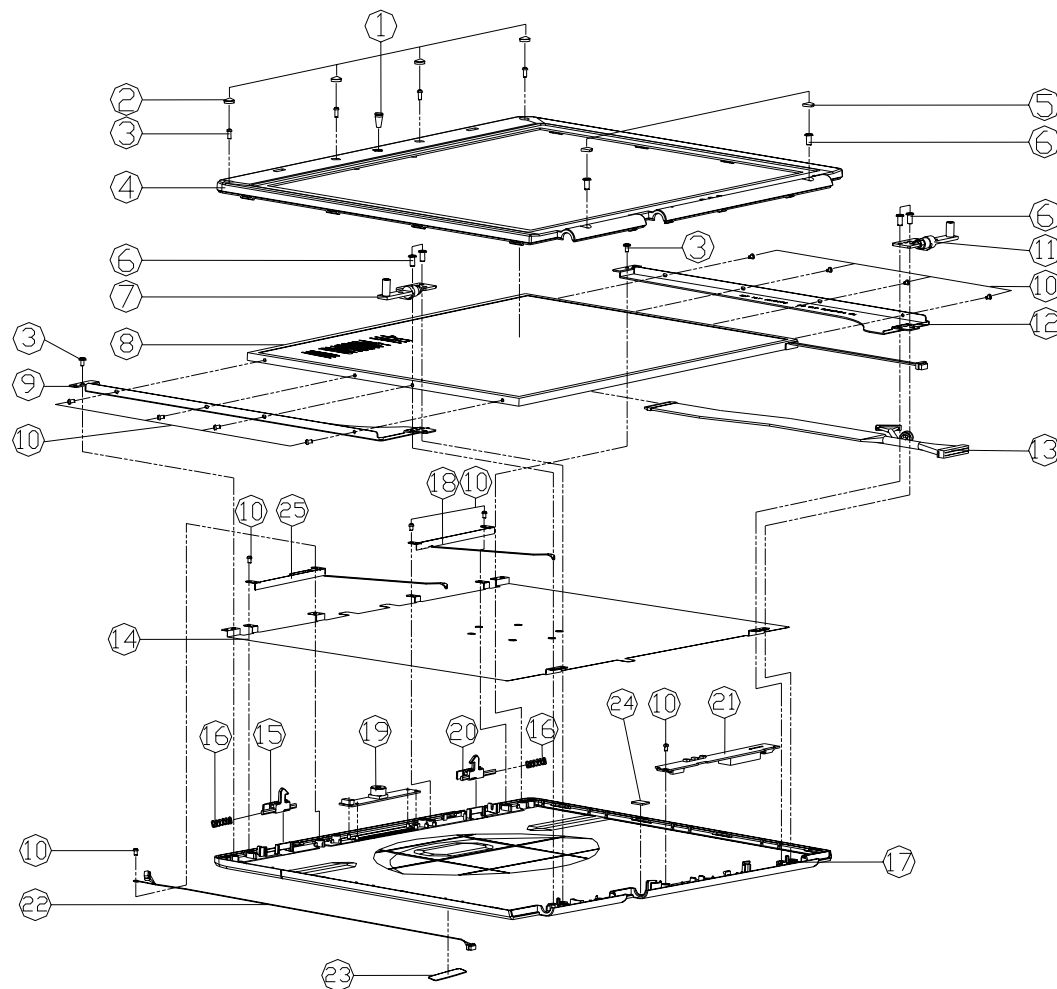

Figure 13
LCD 14" (410S)

ITEM	PART NAME	PART NO	REMARK
1	RUBBER FOR VIDEO CAMERA	47-D400P-010	
2	RUBBER FOR LCD (TOP)	47-56P32-010	
3	SCREW M2*4L I BZ ICT	35-C6120-4R0	
4	DISPLAY FRONT PANEL 14.1" MODULE	39-D4001-100	
5	DISPLAY RUBBER PAD (DOWN)	47-D4001-020	
6	SCREW M3*6L KI NI ICT NY	35-B1130-6RA	
7	HINGE (L)	33-D400Y-020	
8	LCD T AU B141W04 V.1 14.1" XGA	50-J2287-G04	
8	LCD T BM ITX77-E53-029 14.1" XGA	50-J2287-E01	
9	LCD BRACKET (L) FOR AU 14.1" LCD	33-D4001-120	
9	LCD BRACKET (L) FOR 14.1" LCD	33-D4001-020	
10	SCREW M2*3L KI NI ICT NY	35-B1120-3RB	
11	HINGE (R)	33-D400Y-010	
12	LCD BRACKET (R) FOR AU 14.1" LCD	33-D4001-110	
12	LCD BRACKET (R) FOR 14.1" LCD	33-D4001-010	
13	WIRE CABLE FOR 14" LCD XGA AU	43-D4001-021	
14	LCD SHIELDING	33-D4001-050	
15	LCD HOOK(L)	42-D4001-020	
16	SPRING FOR HOOK(#3.7*15*0.3a)	38-21P30-011	
17	DISPLAY BACK PANEL, MODULE D410S	39-D4101-200	
17	DISPLAY BACK PANEL, MODULE M410S	39-M4101-200	
18	WIRELESS ANTENNA PIFA 2.4G L:430mm D400S	23-742R4-004	
19	VIDEO CAMERA CM0130, 300K Pixels Resolu	88-D40C0-410	OPTION
20	LCD HOOK(R)	42-D4001-010	
21	INVERTER BOARD	77-4200R-002-1	
22	WIRE CABLE MAIN BD TO CCD MODULE	43-D4000-060	OPTION
23	NAME PLATE "NOTEBOOK"	45-42001-010	
24	GASKET FOR Y CABLE(L:10mm H:2mm L:15mm)	47-00190-158	
25	ANTENNA BLUETOOTH PIFA 2.4G L:540mm	23-742R4-005	

A.Part Lists

LCD 15" (410S)

Figure 14
LCD 15" (410S)

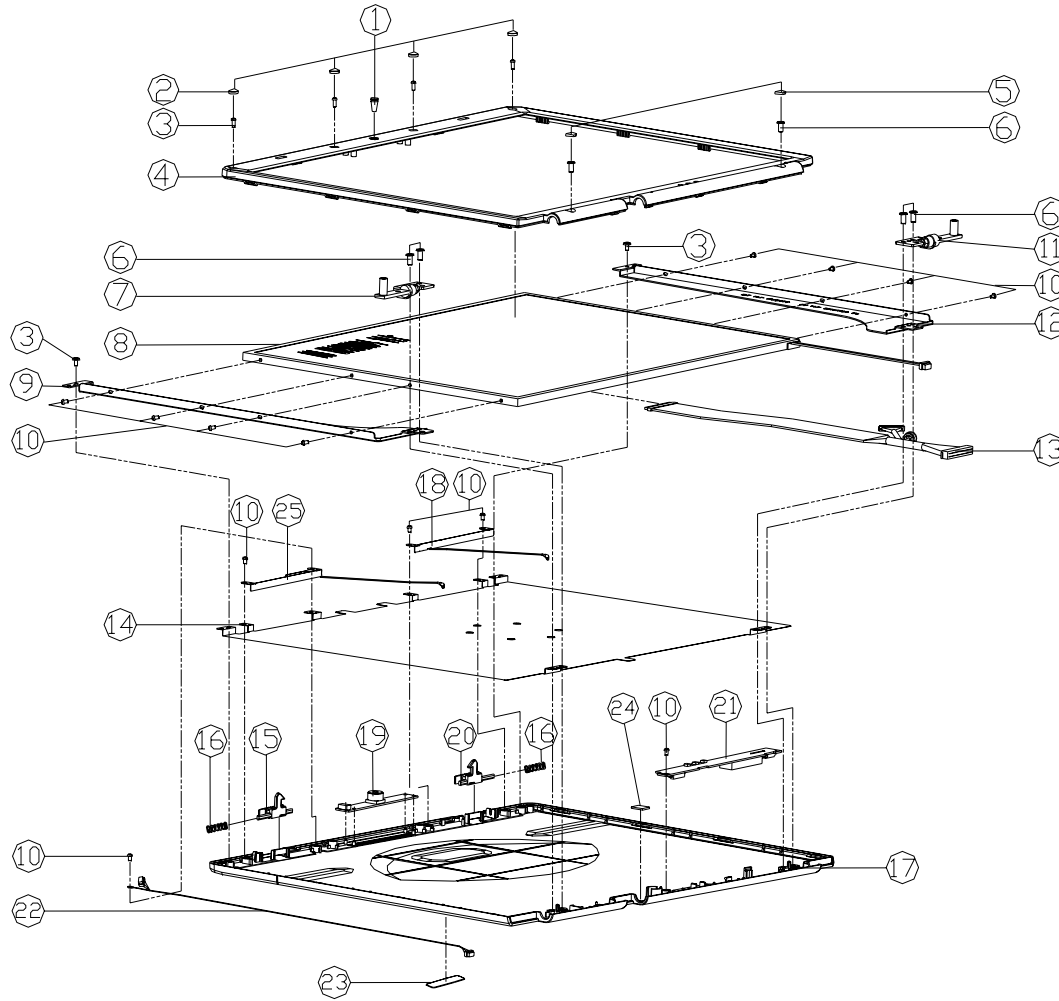

ITEM	PART NAME	PART NO	REMARK
1	RUBBER FOR VIDEO CAMERA	47-D400P-010	
2	RUBBER FOR LCD (TOP)	47-56P32-010	
3	SCREW M2*4L I BZ ICT	35-C6120-4R0	
4	DISPLAY FRONT PANEL 15" MODULE	39-D4001-110	
5	DISPLAY RUBBER PAD (DOWN)	47-D4001-020	
6	SCREW M3*6L KI NI ICT NY	35-B1130-6RA	
7	HINGE (L)	33-D400Y-020	
8	LCD IS0 1FT AU B15PMD1 1400*1050 SXGA+	50-L5259-U10	
8	LCD IS0 1BM 1FT BEM9SC-02 SXGA+ 41mm	50-L3241-E00	
9	LCD BRACKET (L) FOR AU 15.1" LCD	33-D4001-140	
9	LCD BRACKET (L) FOR 1BM 15.1" LCD	33-D4001-240	
10	SCREW M2*3L KI NI ICT NY	35-B1120-3RB	
11	HINGE (R)	33-D400Y-010	
12	LCD BRACKET (R) FOR AU 15.1" LCD	33-D4001-130	
12	LCD BRACKET (R) FOR 1BM 15.1" LCD	33-D4001-230	
13	WIRE CABLE FOR 15" LCD SXGA+ AU	43-D4001-120	
13	WIRE CABLE FOR 15" LCD SXGA+ IDT	43-D4001-110	
14	LCD SHIELDING	33-D4001-050	
15	LCD HOOK(L)	42-D4001-020	
16	SPRING FOR HOOK(φ3.7*15*0.3φ)	38-21P30-011	
17	DISPLAY BACK PANEL MODULE D410S	39-D4101-201	
17	DISPLAY BACK PANEL MODULE M410S	39-M4101-200	
18	WIRELESS ANTENNA PIFA 2.4G L=430mm D40S	23-742R4-004	
19	VIDEO CAMERA CM3130, 300K Pixels Resolu	88-D400C-410	OPTION
20	LCD HOOK(R)	42-D4001-010	
21	INVERTER BOARD	77-4200R-D02-1	
22	WIRE CABLE MAIN BD TO CCD MODULE	43-D4000-060	OPTION
23	NAME PLATE "NOTEBOOK"	45-42001-010	
24	GASKET FOR V CABLE(φ10mm H2mm L15mm)	47-00190-15B	
25	ANTENNA BLUETOOTH PIFA 2.4G L=540mm	23-742R4-005	

CD-ROM Drive (410S)

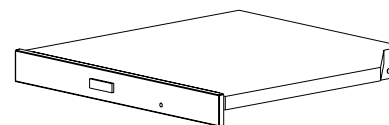
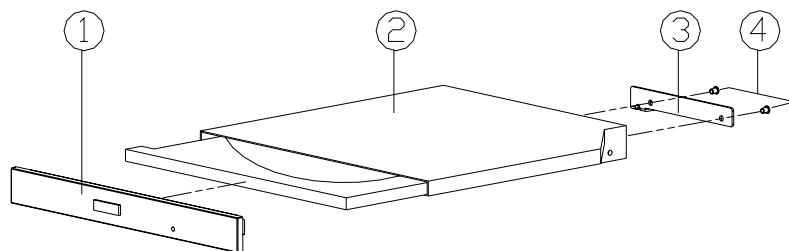

Figure 15
CD-ROM Drive
(410S)

ITEM	PART NAME	PART NO	REMARK
1	OS1 CD-ROM BEZEL MODULE D410S	42-D410Z-101	
1	TEAC CD-ROM BEZEL MODULE D410S	42-D410Z-301	
2	CD-ROM 5 1/4" 24X CAB SLIM OS1(SCR-242)	85-607□X-C00	
2	CD-ROM 5 1/4" 24X CD-224E-C20 12.7mm TEAC	85-607□X-709	
3	CDROM LOCK BRACKET	33-D400Z-010	
4	SCREW M2*3L KI NI ICT NY	35-B1120-3RB	

A.Part Lists

CD-RW Drive (410S)

Figure 16
CD-RW Drive
(410S)

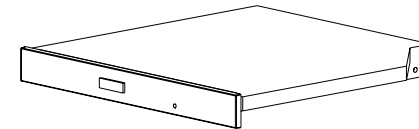
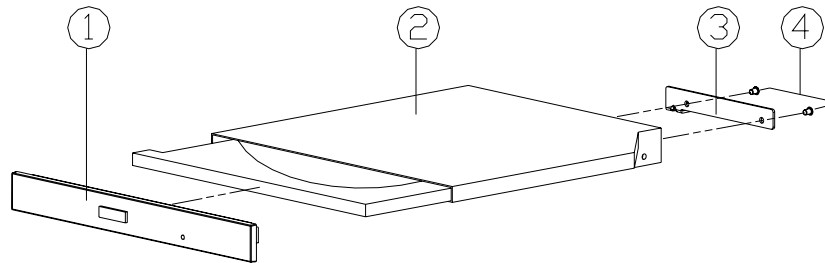

ITEM	PART NAME	PART NO	REMARK
1	TEAC CD-RW BEZEL MODULE D410S	42-D410W-101	
1	TOSHIBA CD-RW BEZEL MODULE D410S	42-D410W-201	
2	CD-R/W 5 1/4" 24X CD-W224E-A82 12.7mm TEAC	85-807DX-700	
2	CD-R/W 5 1/4" 16X SR-C8102 12.7mm TOSHIBA	85-807GX-T00	
3	CDROM LOCK BRACKET	33-D400Z-010	
4	SCREW M2*3L KI NI ICT NY	35-B1120-3RB	

Combo Drive (410S)

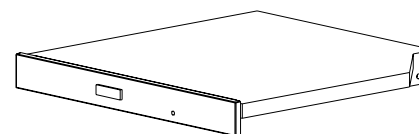
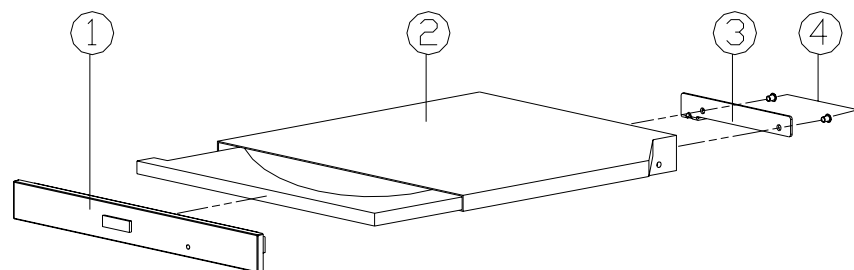

Figure 17
Combo Drive
(410S)

ITEM	PART NAME	PART NO	REMARK
1	OSI COMBO BEZEL MODULE D410S	42-D410X-101	
1	SAMSUNG COMBO BEZEL MODULE D410S	42-D410X-201	
1	TEAC COMBO BEZEL MODULE D410S	42-D410X-300	
2	CD-RW/DVD 5 1/4" 24X 12.7mm SBW-241 OSI	85-907□X-C00	
2	CD-RW/DVD 5 1/4" 24X 12.7mm SN-324 SAMSUNG	85-907□X-S00	
2	CD-RW/DVD 5 1/4" 24X 12.7mm DW-224E TEAC	85-907□X-700	
3	CDROM LOCK BRACKET	33-D400Z-010	
4	SCREW M2*3L KI NI ICT NY	35-B1120-3RB	

A.Part Lists

DVD-ROM Drive (410S)

Figure 18
DVD-ROM Drive
(410S)

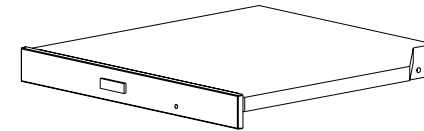
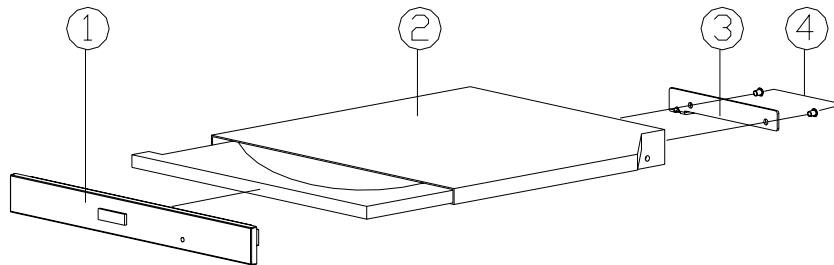

ITEM	PART NAME	PART NO	REMARK
1	OSI DVD-ROM BEZEL MODULE D410S	42-D410V-101	
1	TEAC DVD-ROM BEZEL MODULE D410S	42-D410V-201	
2	DVD 5 1/4" 8X 12.7mm SDR-083 OSI	85-7078X-C02	
2	DVD 5 1/4" 8X 12.7mm DV-28E-B82 TEAC	85-7078X-700	
3	CDROM LOCK BRACKET	33-D400Z-010	
4	SCREW M2*3L KI NI ICT NY	35-B1120-3RB	

Floppy Disk Drive (410S)

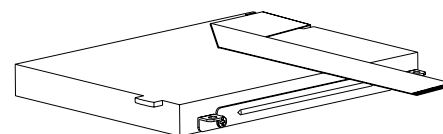
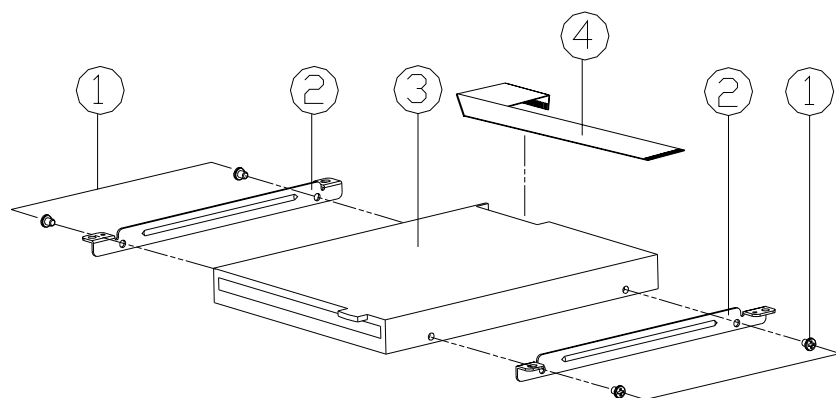
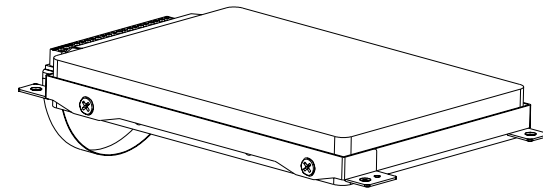
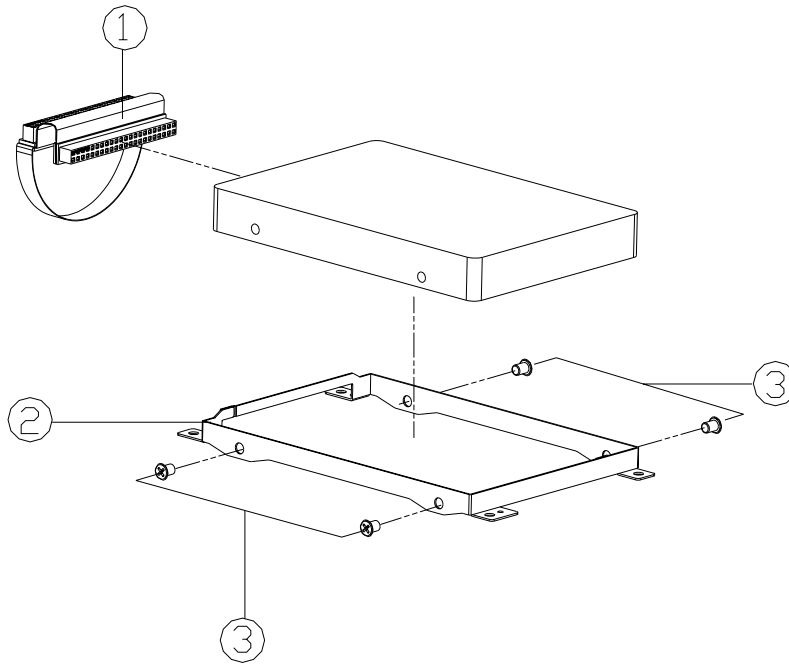

Figure 19
Floppy Disk Drive
(410S)

ITEM	PART NAME	PART NO	REMARK
1	SCREW M2.5*3L KI BK/D.NY	35-B4125-3RA	
2	FDD BRACKET	33-D400J-010	
3	FDD 3.5" 1.44MB 12.7mm (YD-702J-6637J)	85-11700-Y01-01	
4	FFC CABLE FOR MAIN BD TO FDD 180MM	43-D4000-050	

Hard Disk Drive (410S)

Figure 20
HDD Drive (410S)



ITEM	PART NAME	PART NO	REMARK
1	FPC CABLE FOR HD TO MAIN BD, 30MM,8880	43-88800-010	
2	HDD BRACKET	77-22004-D03A	
3	SCREW M3*4L KI BZ ICT NY	35-B6130-4RB	

Appendix B:Schematic Diagrams

This appendix has circuit diagrams of the *D400S/D410S* notebook's PCB's. The following table indicates where to find the appropriate schematic diagram.

Diagram - Page	Diagram - Page
<i>System Block Diagram - Page B - 2</i>	<i>USB Port - Page B - 19</i>
<i>Socket 478 1 of 2 - Page B - 3</i>	<i>PCMCIA TII410 - Page B - 20</i>
<i>Socket 478 & ITP 2 of 2 - Page B - 4</i>	<i>PCMCIA Power - Page B - 21</i>
<i>Clock Generator - Page B - 5</i>	<i>1394 PHY TSB41LV01 - Page B - 22</i>
<i>M650 (Host/AGP) 1 of 4 - Page B - 6</i>	<i>LPC SI/O - Page B - 23</i>
<i>M650 (Memory for DDR) 2 of 4 - Page B - 7</i>	<i>LPT/COM Port - Page B - 24</i>
<i>M650 (& CRT Out) 3 of 4 - Page B - 8</i>	<i>LPC H8 - Page B - 25</i>
<i>M650 (Power) 4 of 4 - Page B - 9</i>	<i>LAN RTL8100BL - Page B - 26</i>
<i>DDR Memory DIMM - Page B - 10</i>	<i>Audio Codec ALC201A - Page B - 27</i>
<i>DDR SSTL-2 Termination - Page B - 11</i>	<i>Audio Out & Off Board Connectors - Page B - 28</i>
<i>LVDS Interface (SiS302LV) - Page B - 12</i>	<i>System Power Control - Page B - 29</i>
<i>Panel Con & LED Indicator - Page B - 13</i>	<i>Fan Control and SpeedStep - Page B - 30</i>
<i>962 (PCI/IDE/HyperZip) 1 of 4 - Page B - 14</i>	<i>VCORE - Page B - 31</i>
<i>962 (Misc Signals) 2 of 4 - Page B - 15</i>	<i>DDR Power - Page B - 32</i>
<i>962 (USB I/F) 3 of 4 - Page B - 16</i>	<i>System - Page B - 33</i>
<i>962 (Power & RTC) 4 of 4 - Page B - 17</i>	<i>Charger - Page B - 34</i>
<i>HDD/Combo Connector - Page B - 18</i>	<i>SW Board and HotKey - Page B - 35</i>

Table 1
Schematic
Diagrams

System Block Diagram

D400 System Block Diagram

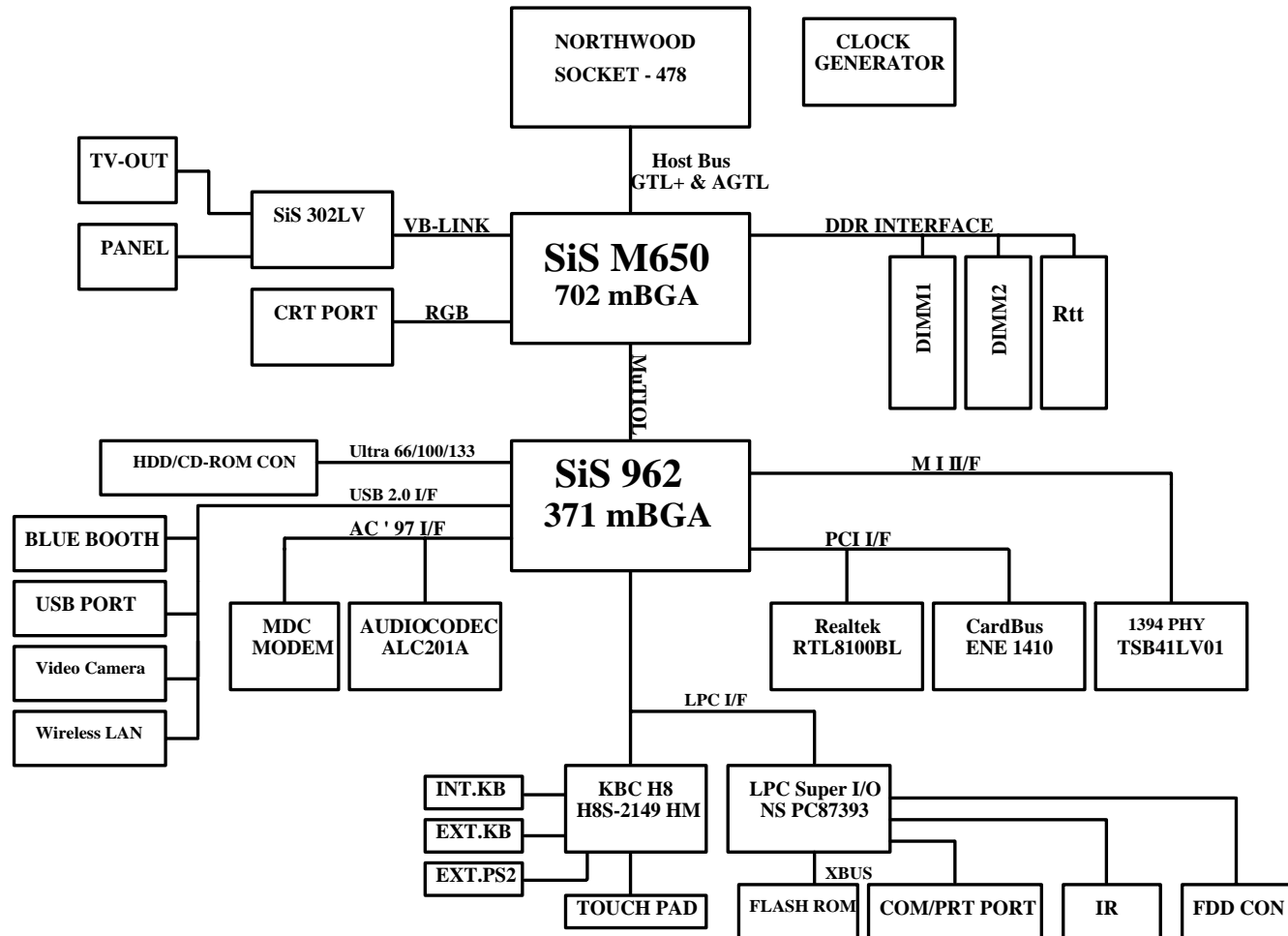

Sheet 1 of 35
System Block
Diagram

Socket 478 1 of 2

B. Schematic Diagrams

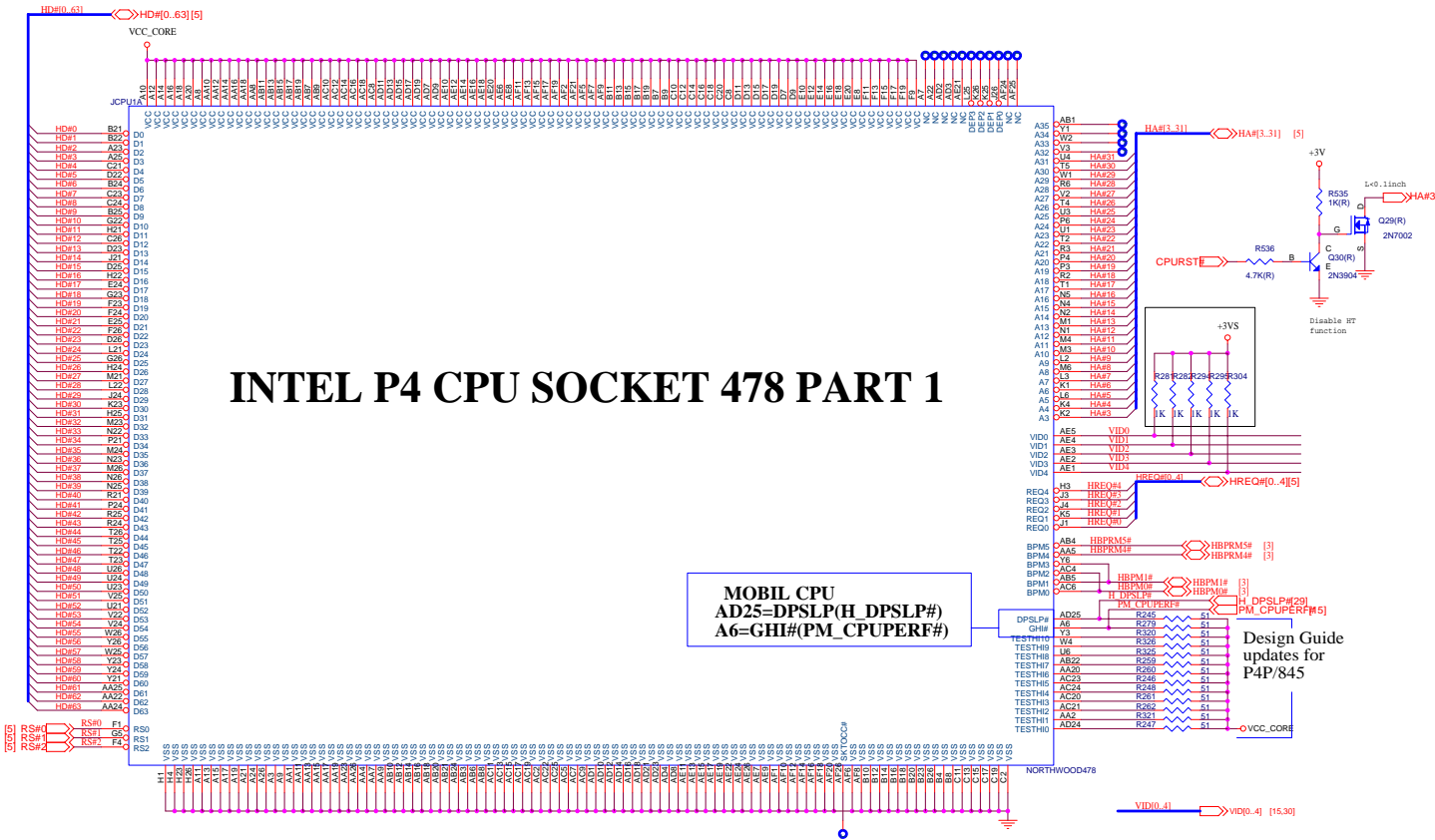

INTEL P4 CPU SOCKET 478 PART 1

Sheet 2 of 35
Socket 478 1 of 2

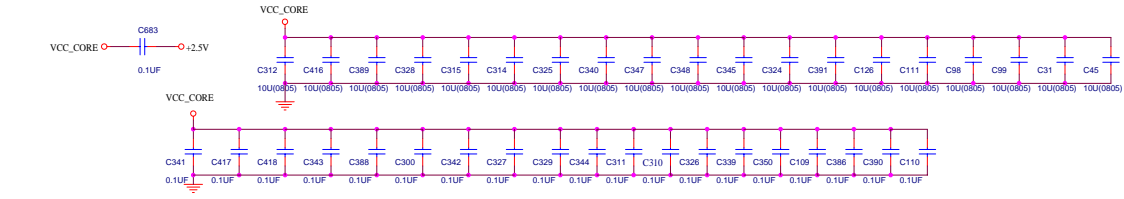

Socket 478 & ITP 2 of 2

Sheet 3 of 35
Socket 478 & ITP
2 of 2

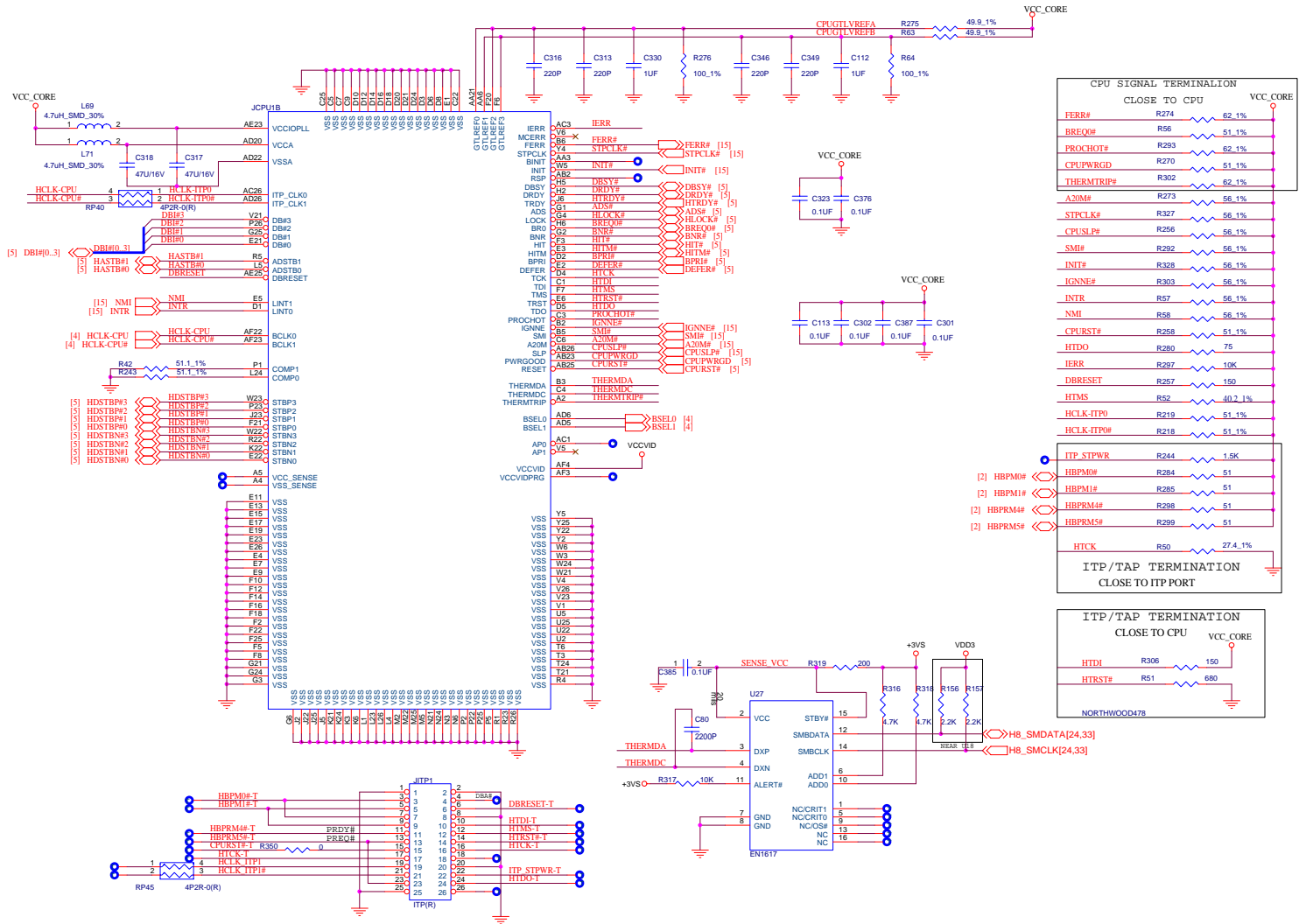

B - 4 Socket 478 & ITP 2 of 2 (71-D4000-D04)

Clock Generator

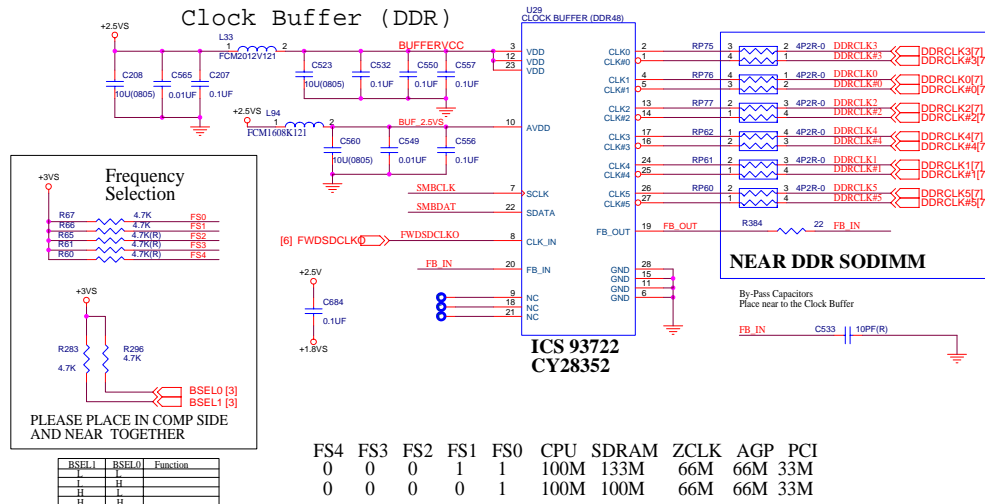
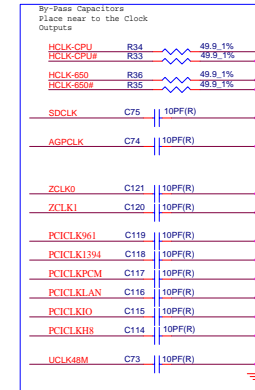
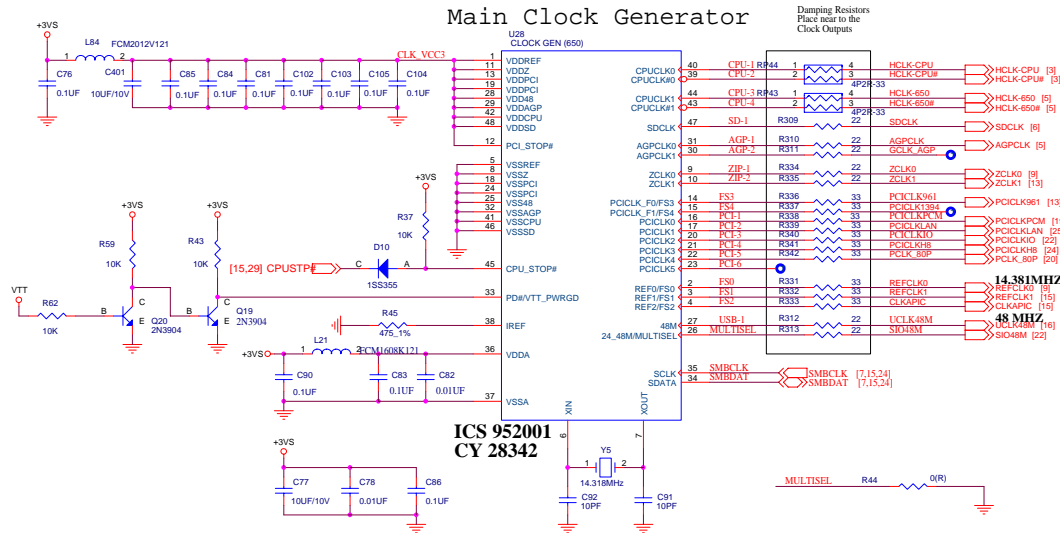

Sheet 4 of 35
Clock Generator

Schematic Diagrams

M650 (Host/AGP) 1 of 4

B.Schematic Diagrams

Sheet 5 of 35
M650 (Host/AGP)
1 of 4

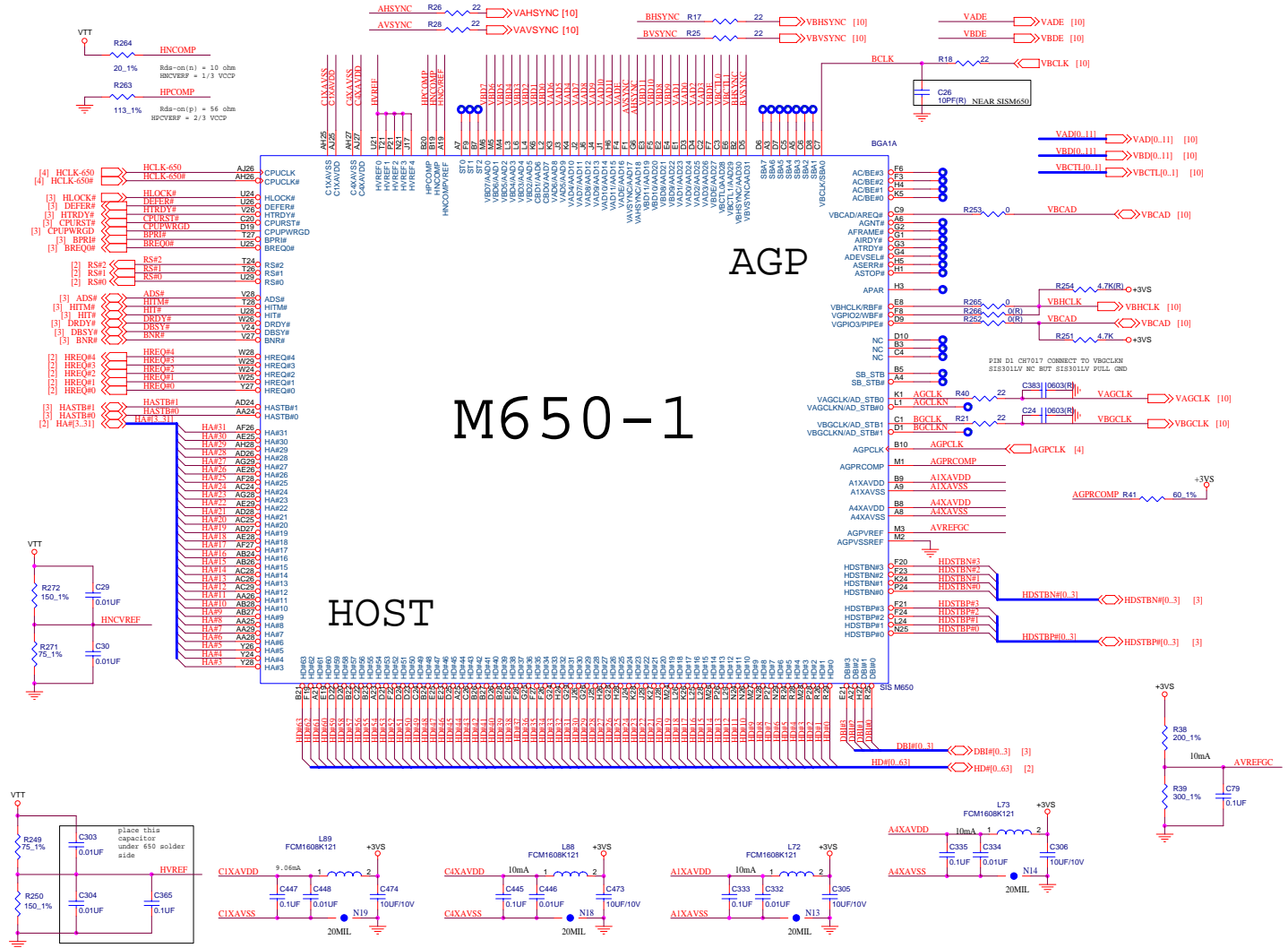

M650-1

B - 6 M650 (Host/AGP) 1 of 4 (71-D4000-D04)

M650 (Memory for DDR) 2 of 4

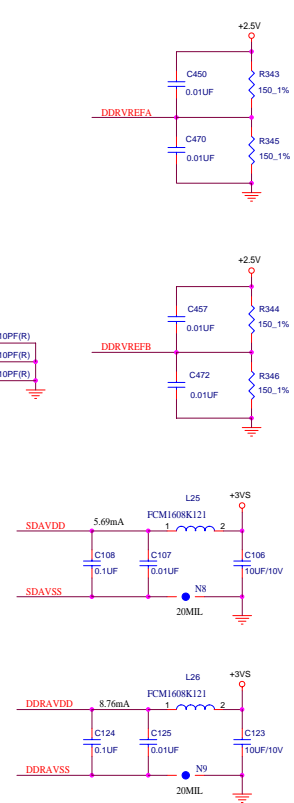
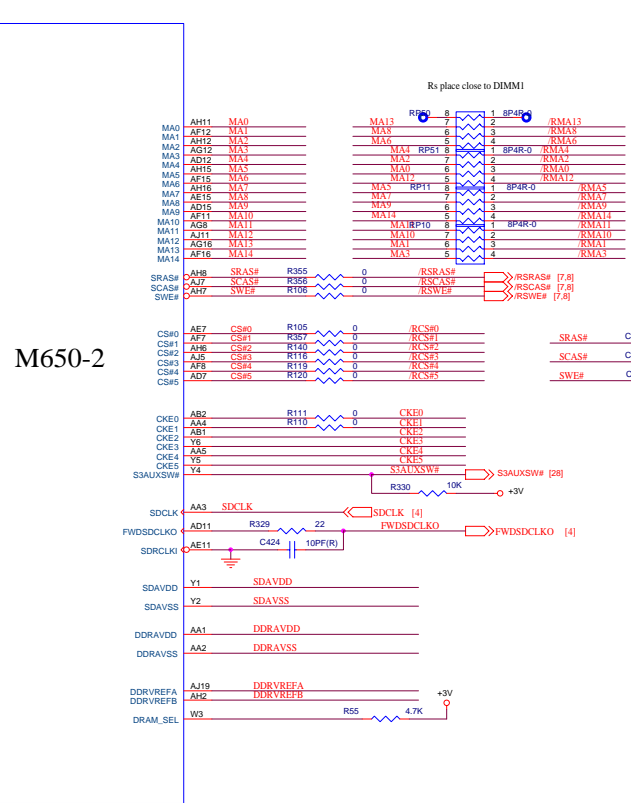
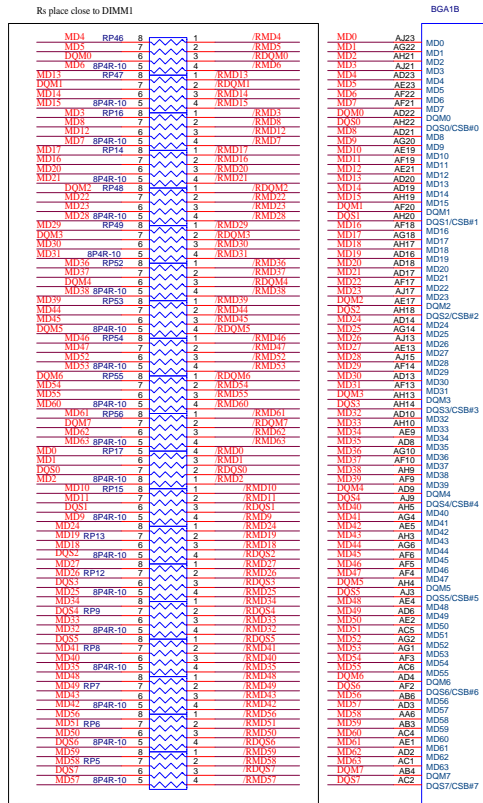
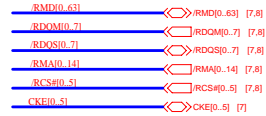

Sheet 6 of 35
M650
 (Memory for DDR)
 2 of 4

B. Schematic Diagrams

M650 (& CRT Out) 3 of 4

Sheet 7 of 35
M650 & CRT Out
3 of 4

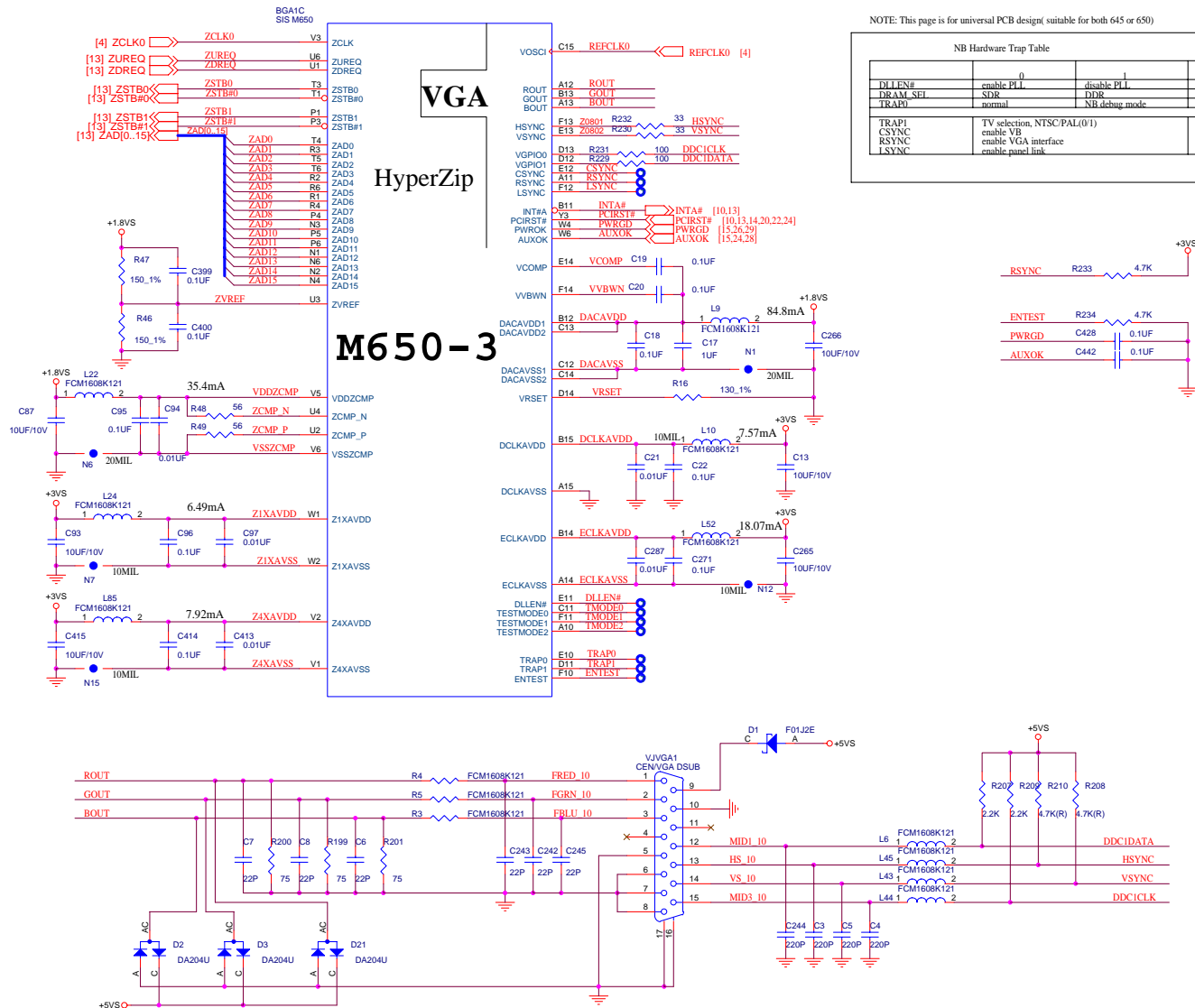

NOTE: This page is for universal PCB design (suitable for both 645 or 650)

Trap	0	1	Default	embedded null-low (30-50K Ohm)
DLLEN#	enable PLL	disable PLL	0	yes
DRAM_SEI	SDR	DDR	1(DDR)	yes
TRAP0	normal	NB debug mode	0	yes
TRAP1	TV selection, NTSC/PAL(0/1)			0
CSYNC	enable VB		0	
RSYNC	enable VGA interface		1	
LSYNC	enable panel link		0	

M650 (Power) 4 of 4

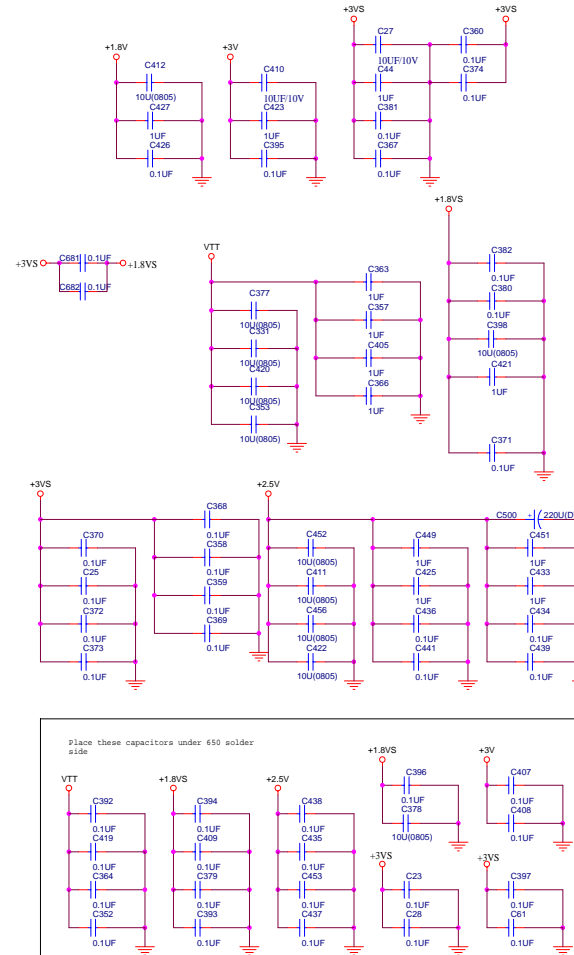
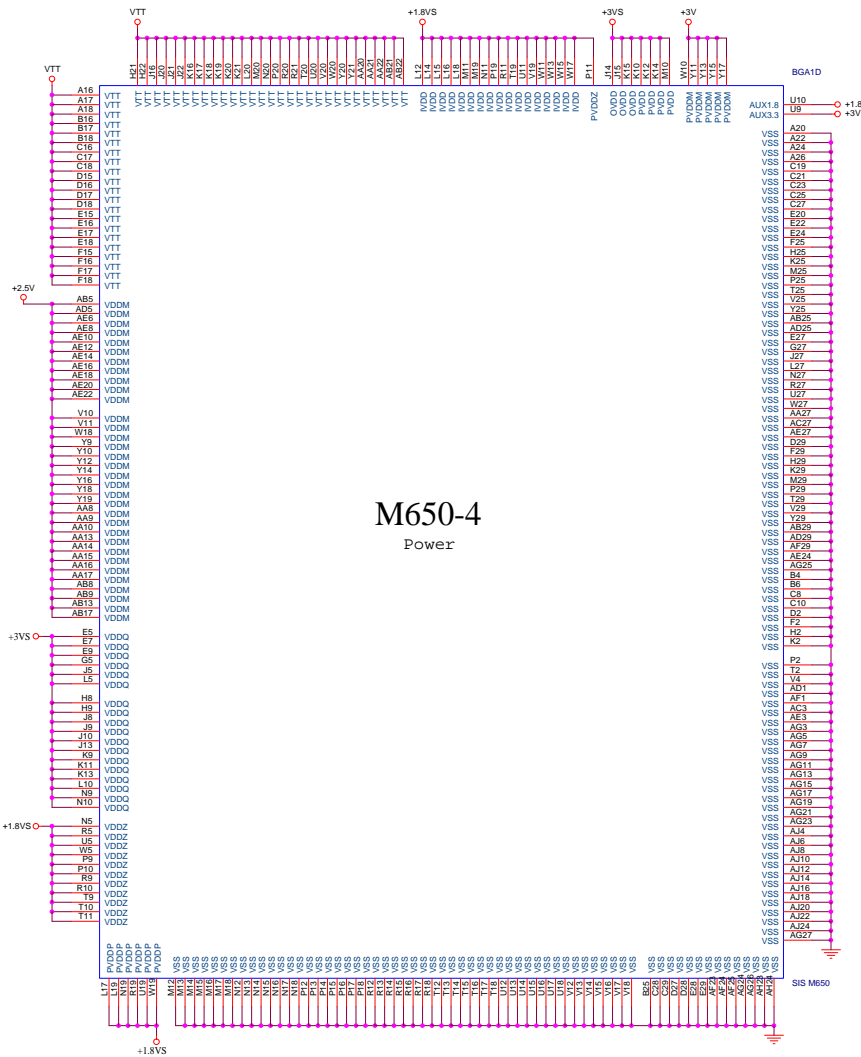

Sheet 8 of 35
M650 (Power)
4 of 4

B. Schematic Diagrams

DDR Memory DIMM

Sheet 9 of 35
DDR Memory DIMM

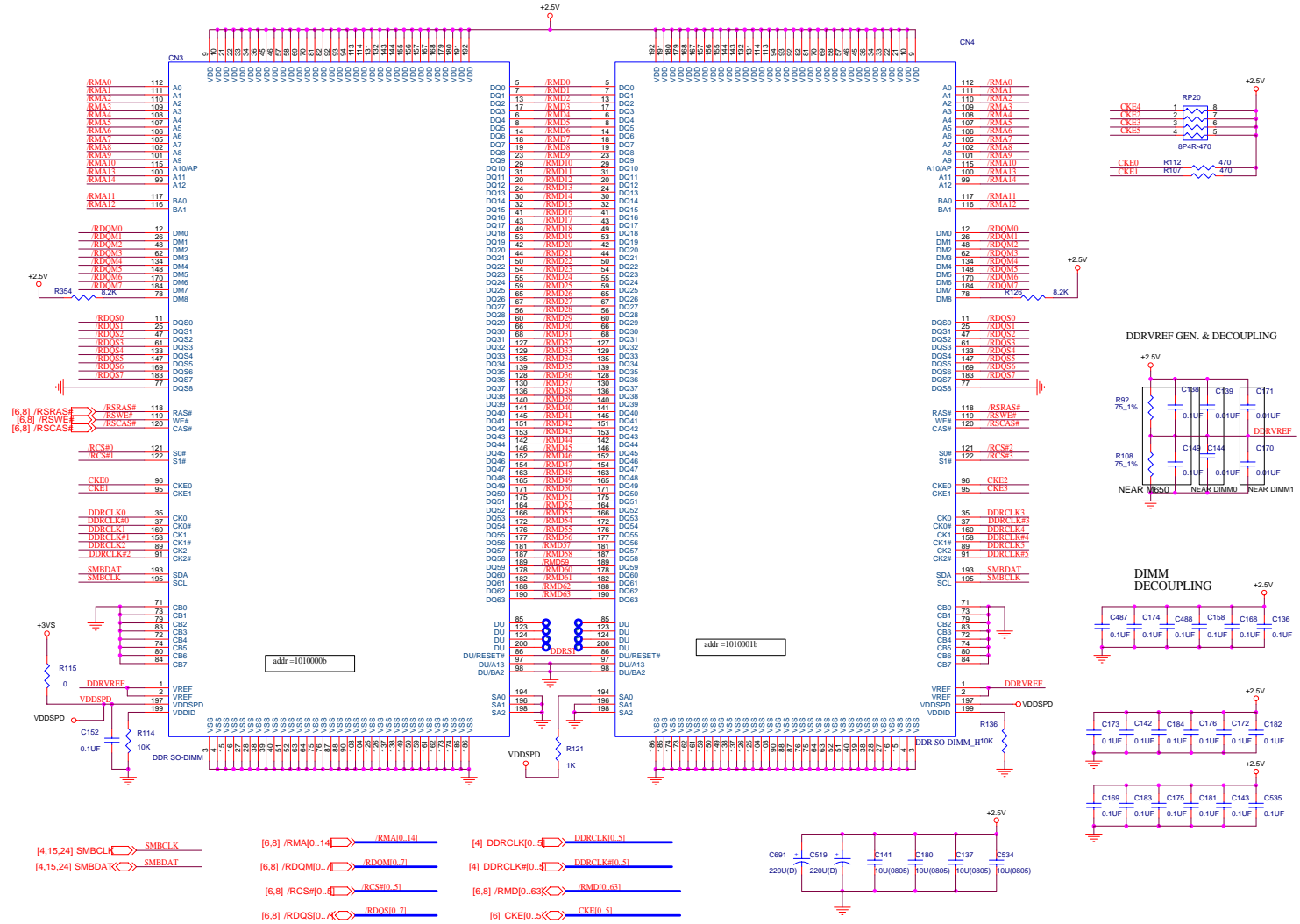

B - 10 DDR Memory DIMM (71-D4000-D04)

DDR SSTL-2 Termination

SSTL-2 Termination Resistors

MD/DQM/(DQS) MA/Control CS	DDR SSTL-2 SSTL-2 OD 2.5V	R_s 10 0 0	R_{tt} 33 33 47

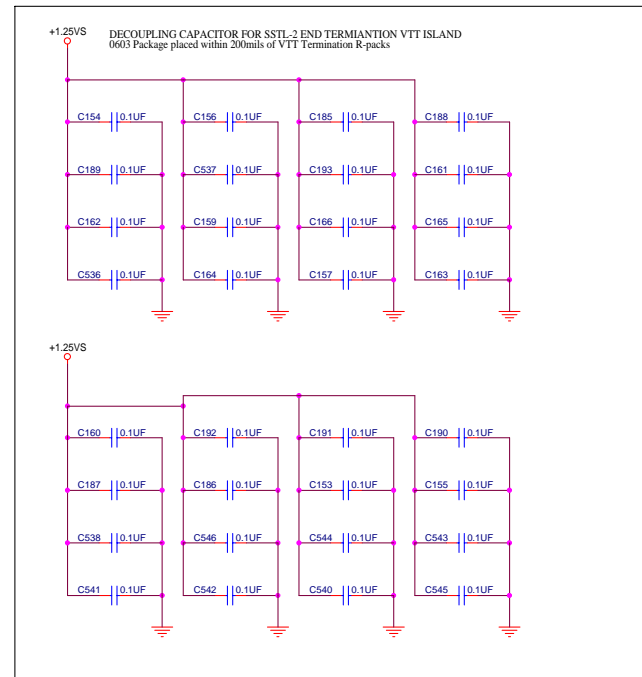
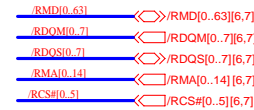
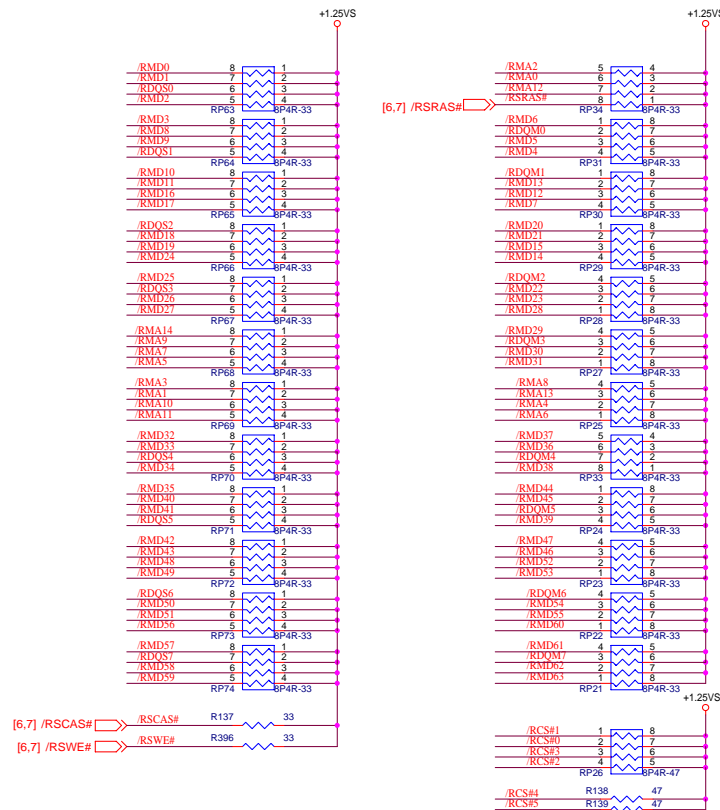

Sheet 10 of 35
DDR SSTL-2
Termination

B. Schematic Diagrams

LVDS Interface (SiS302LV)

Sheet 11 of 35
LVDS interface
(Sis302LV)

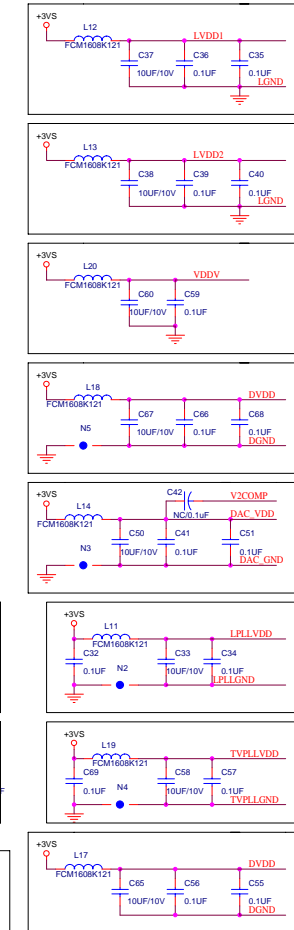
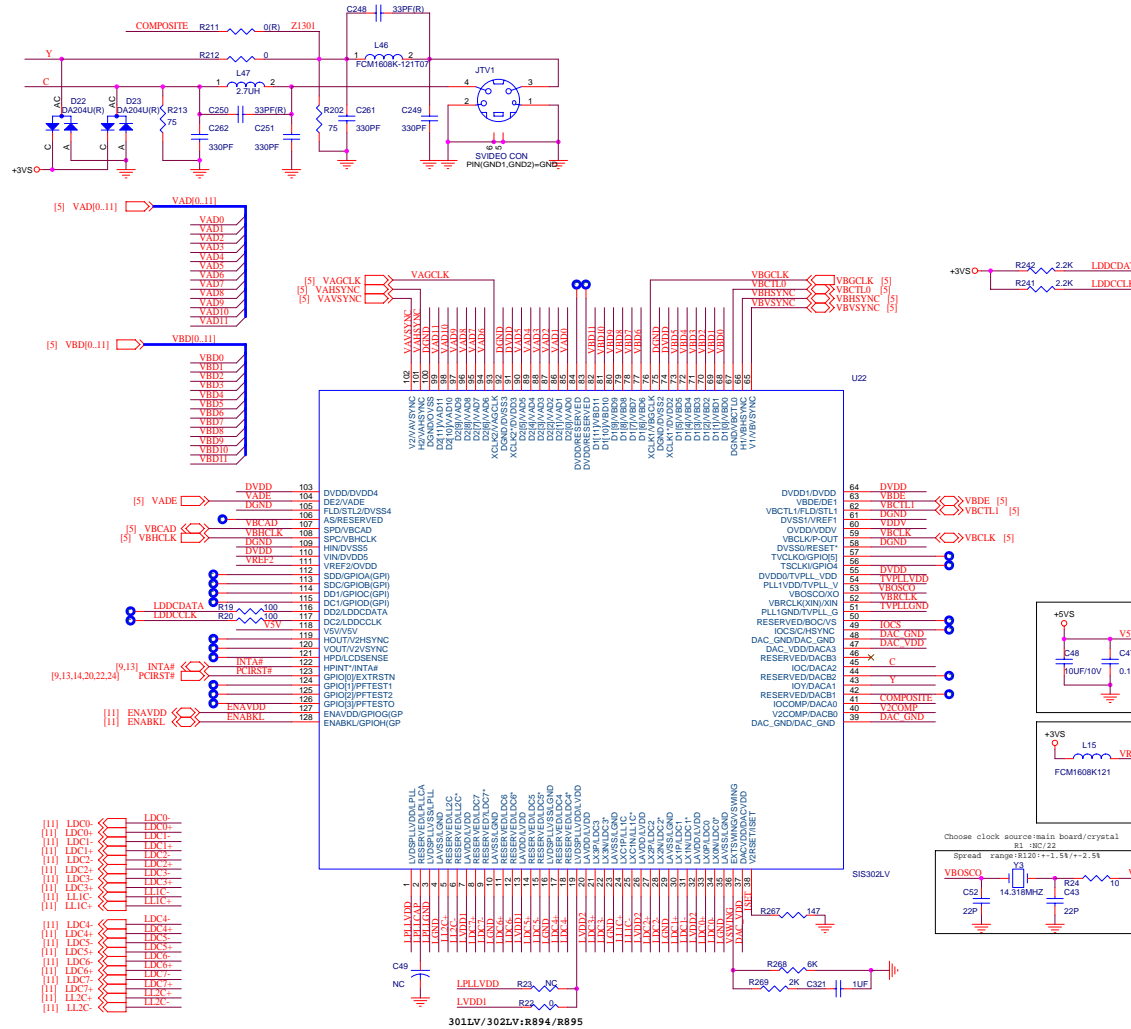

B - 12 LVDS Interface (SiS302LV) (71-D4000-D04)

Panel Con & LED Indicator

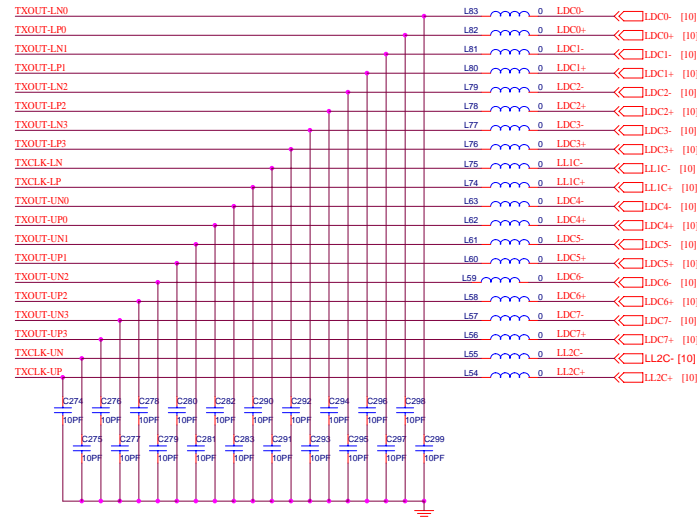
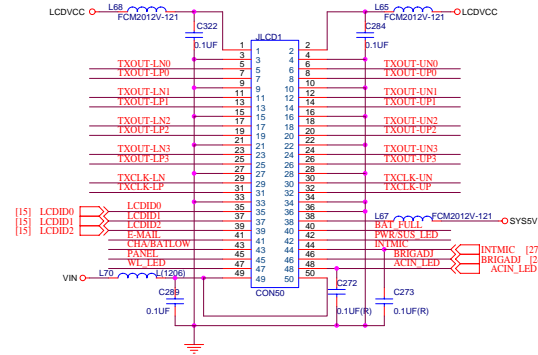
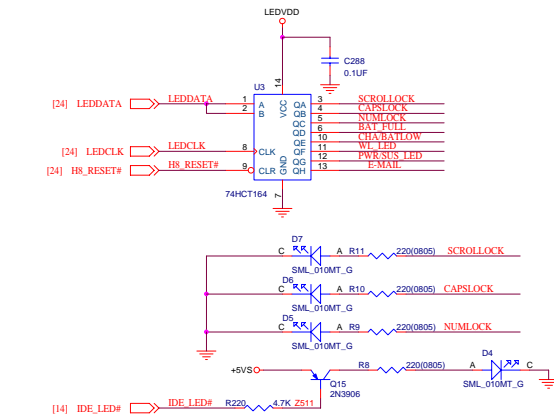
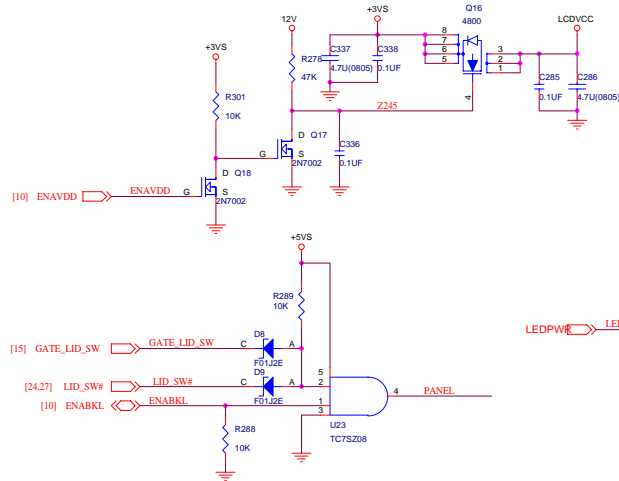

Sheet 12 of 35
Panel Con & LED
Indicator

962 (PCI/IDE/HyperZip) 1 of 4

B.Schematic Diagrams

Sheet 13 of 35
962 (PCI/IDE/
HyperZip)
1 of 4

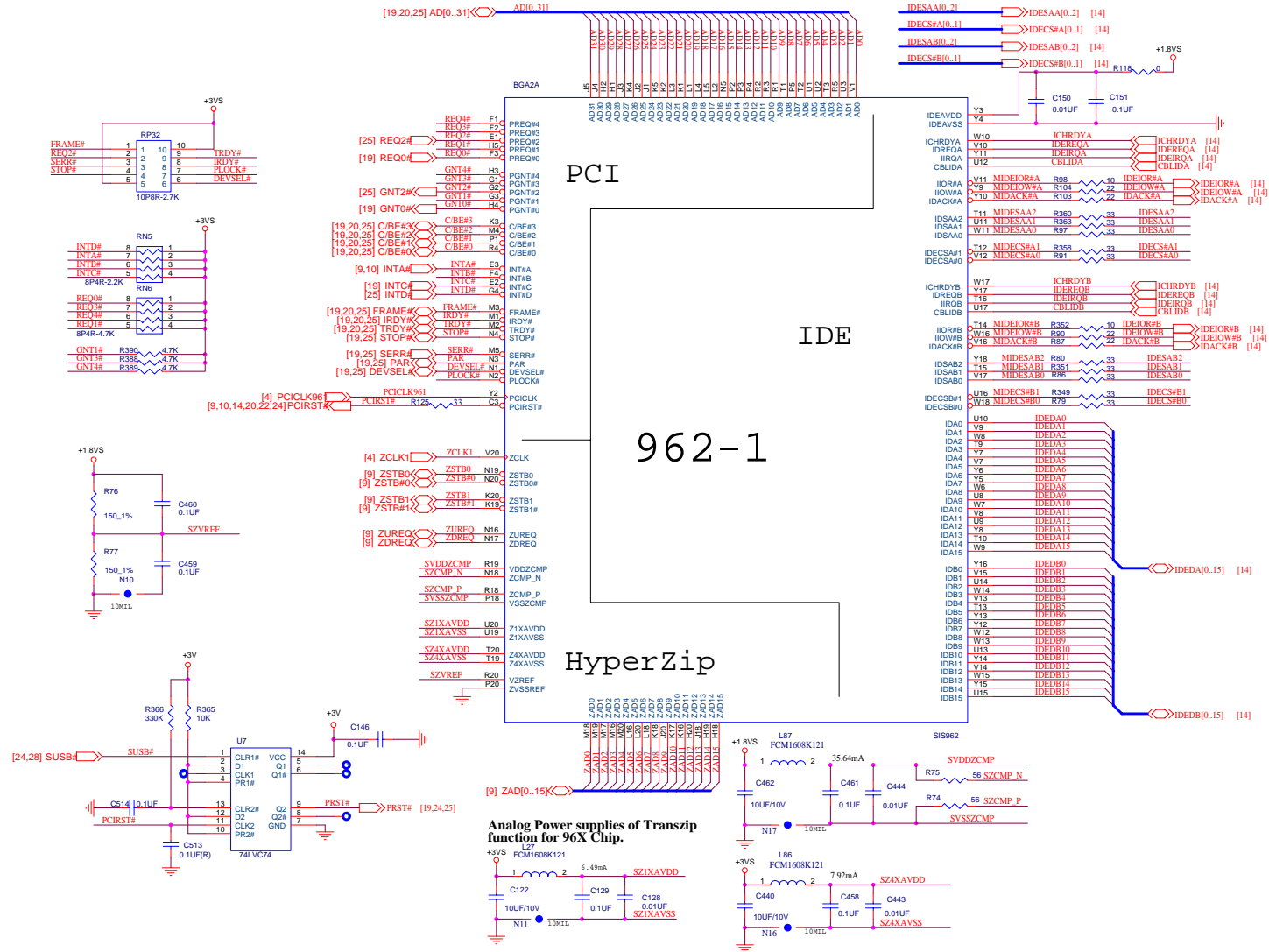

B - 14 962 (PCI/IDE/HyperZip) 1 of 4 (71-D4000-D04)

962 (USB I/F) 3 of 4

Sheet 15 of 35
962 (USB I/F)
3 of 4

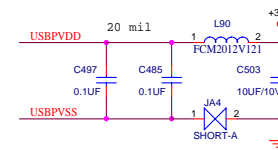
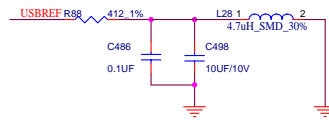
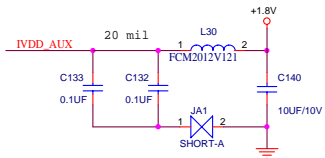
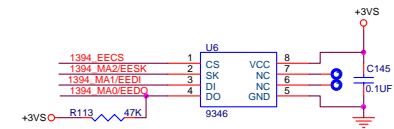
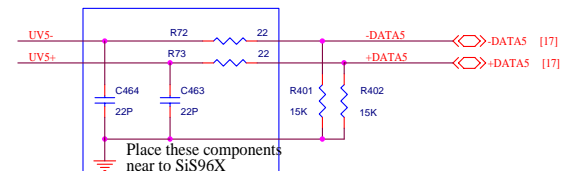
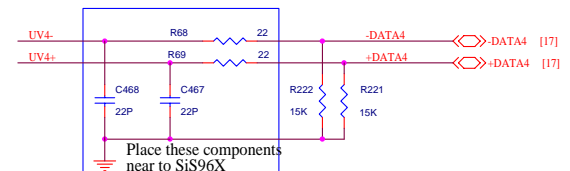
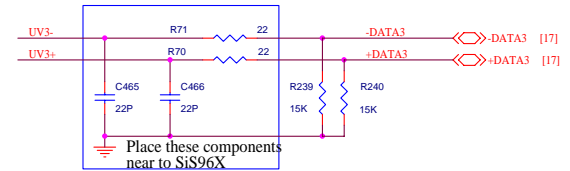
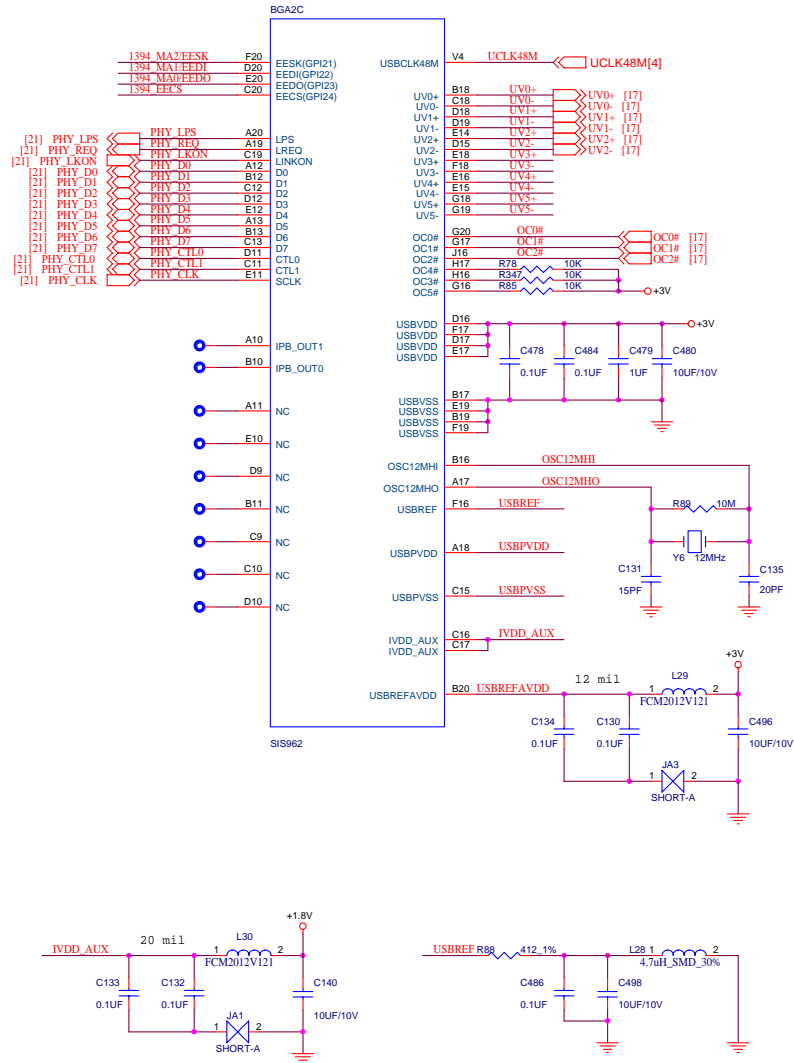

962 (Power & RTC) 4 of 4

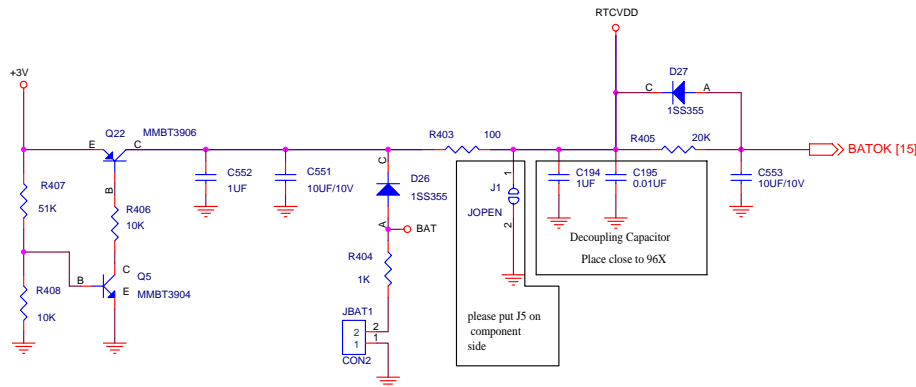
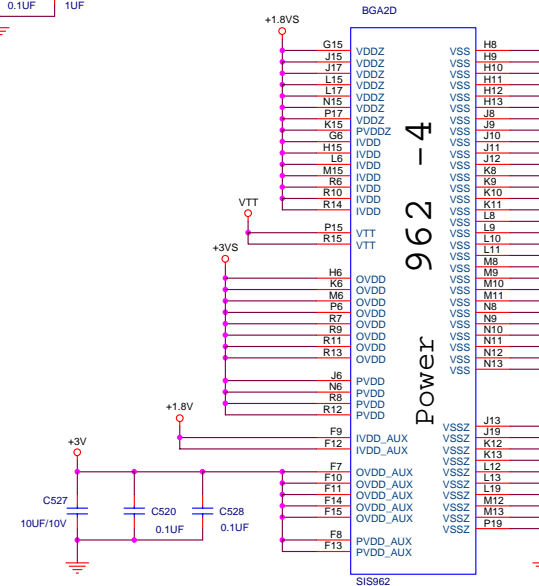
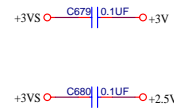
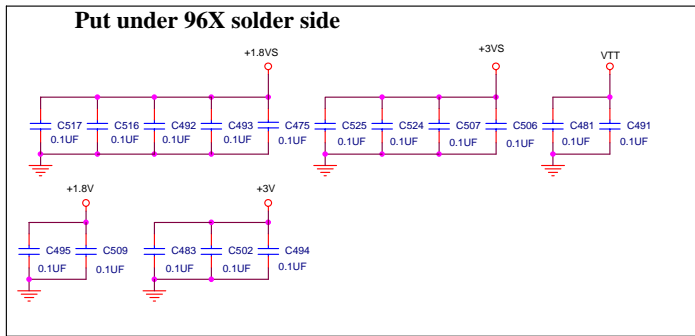
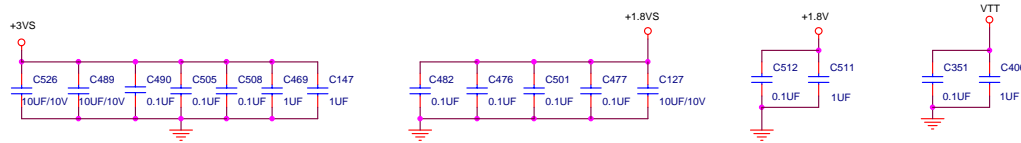

Sheet 16 of 35
962 (Power & RTC)
4 of 4

B.Schematic Diagrams

Schematic Diagrams

HDD/Combo Connector

B.Schematic Diagrams

Sheet 17 of 35
HDD/Combo
Connector

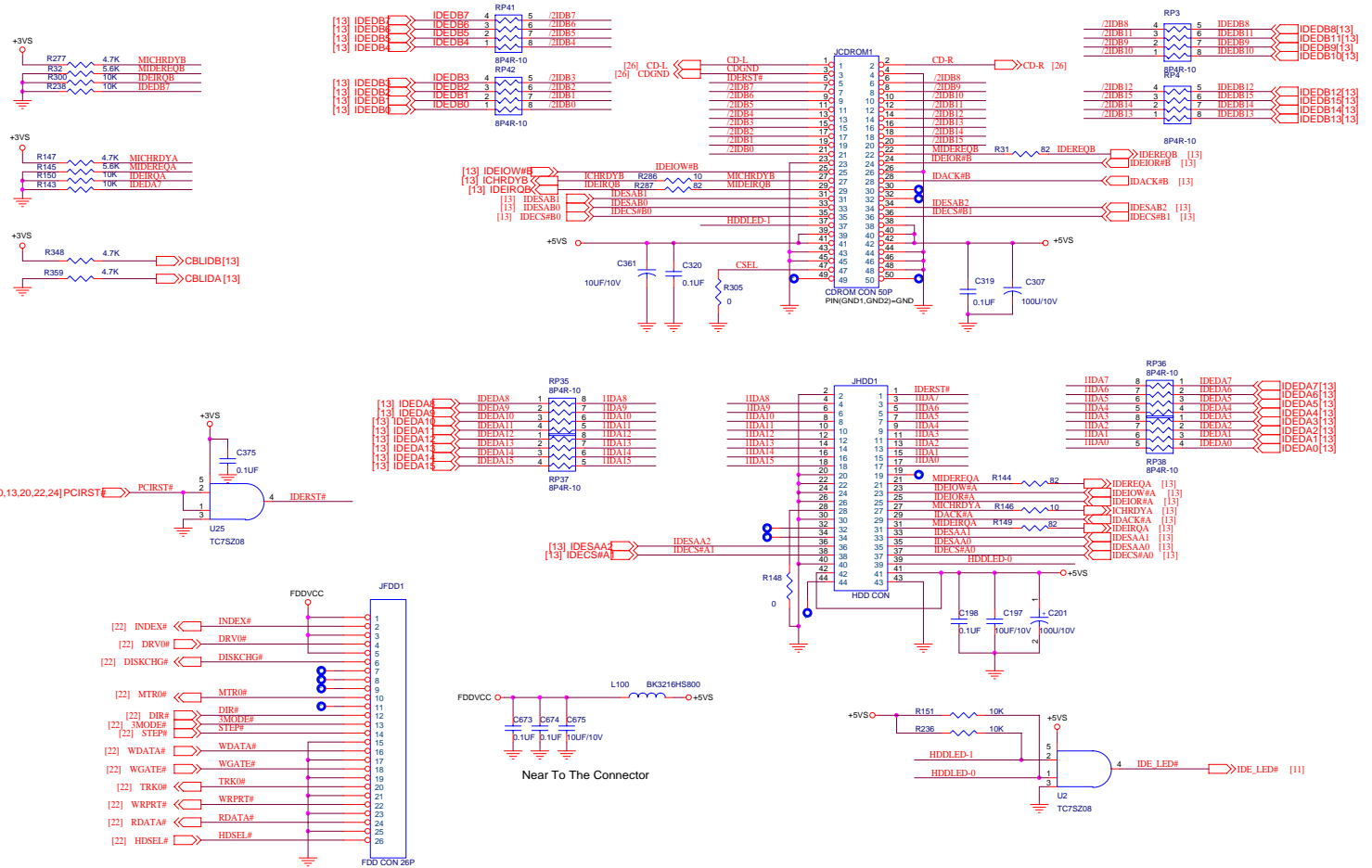

B - 18 HDD/Combo Connector (71-D4000-D04)

USB Port

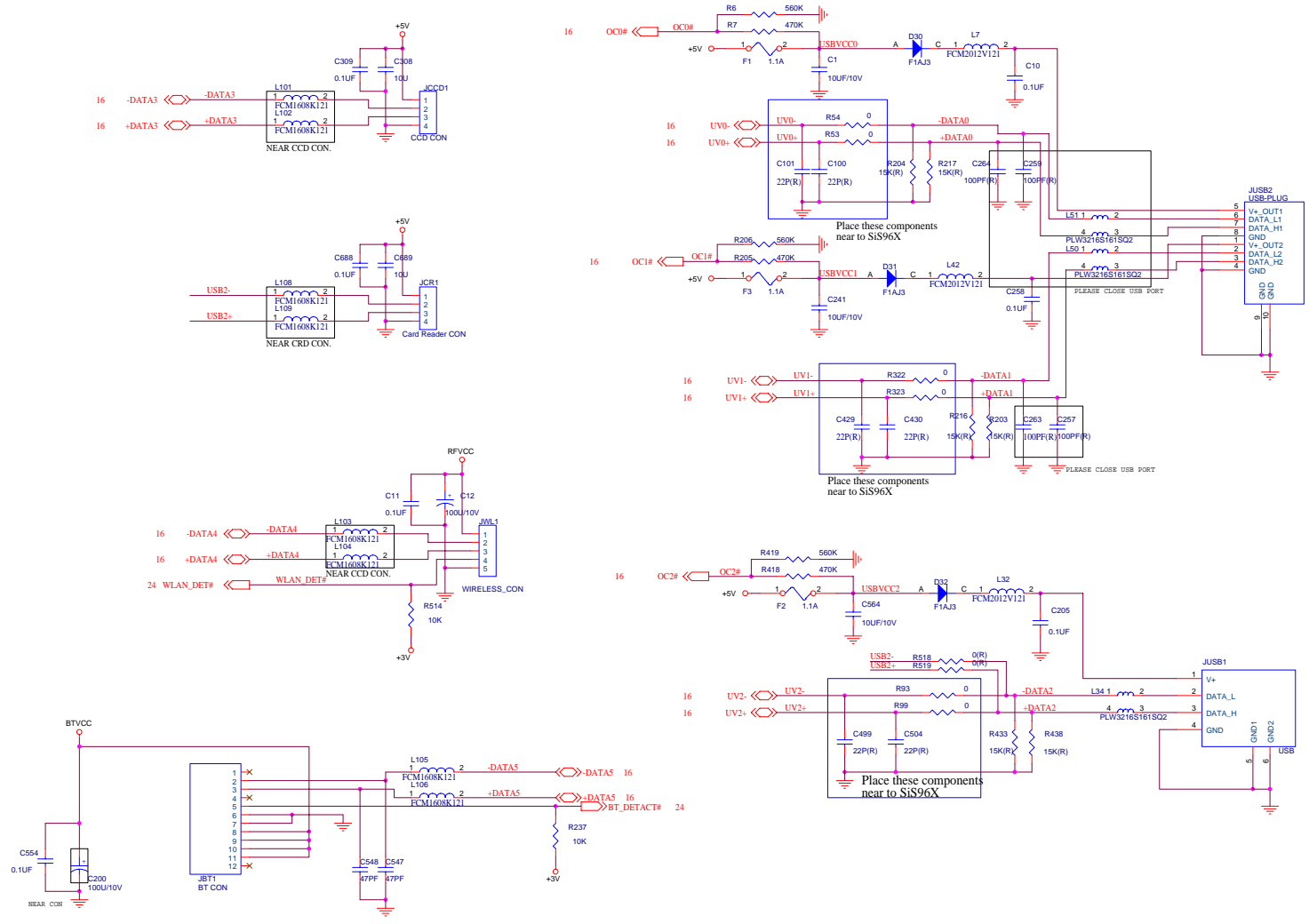

Sheet 18 of 35
USB Port

B.Schematic Diagrams

PCMCIA TI1410

Sheet 19 of 35
PCMCIA TI1410

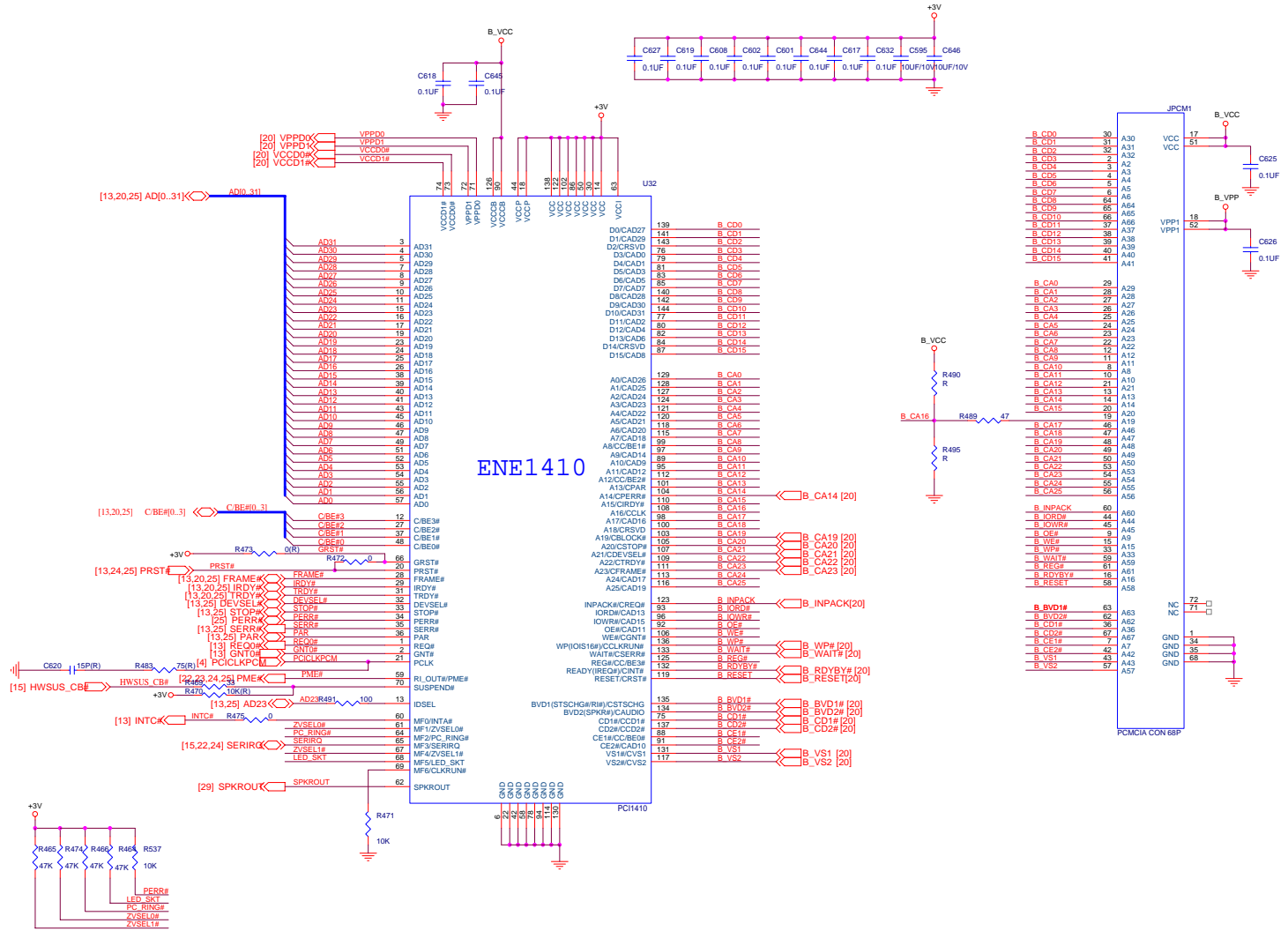

PCMCIA Power

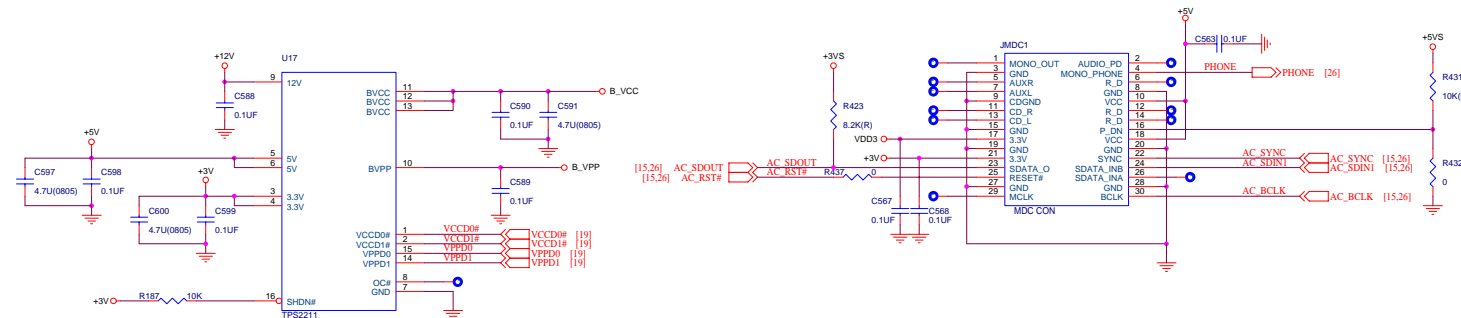

Sheet 20 of 35
PCMCIA Power

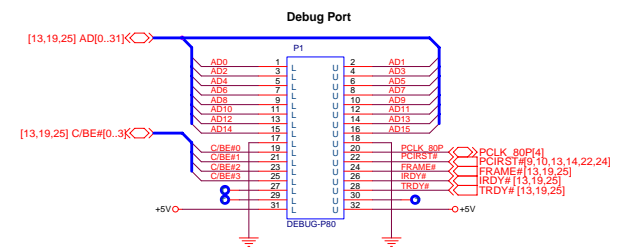
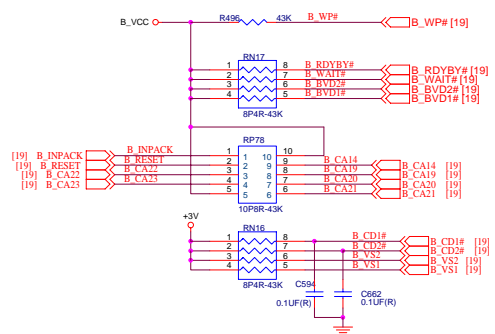

B. Schematic Diagrams

1394 PHY TSB41LV01

Sheet 21 of 35
1394 PHY
TSB41LV01

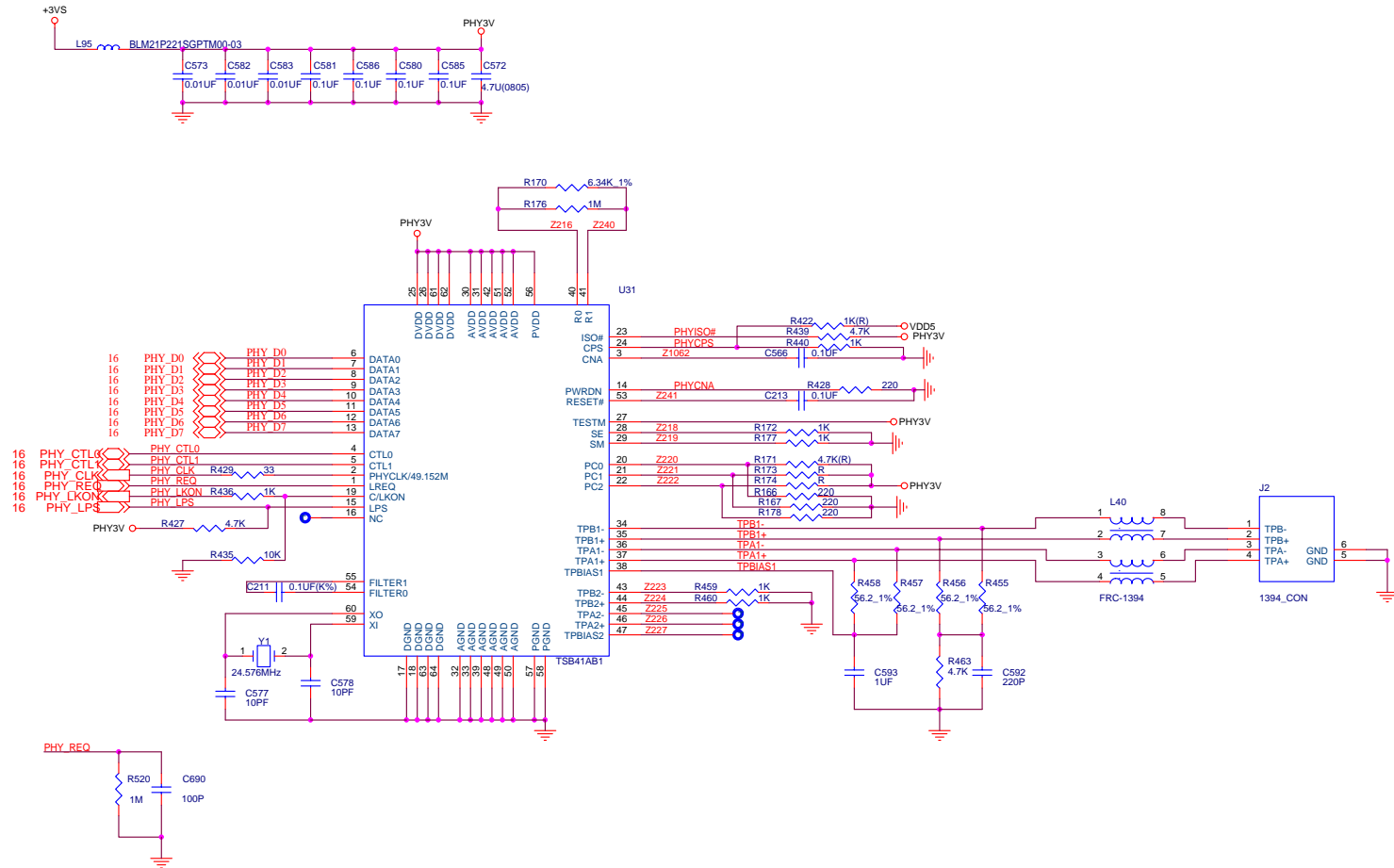

LPC S/I/O

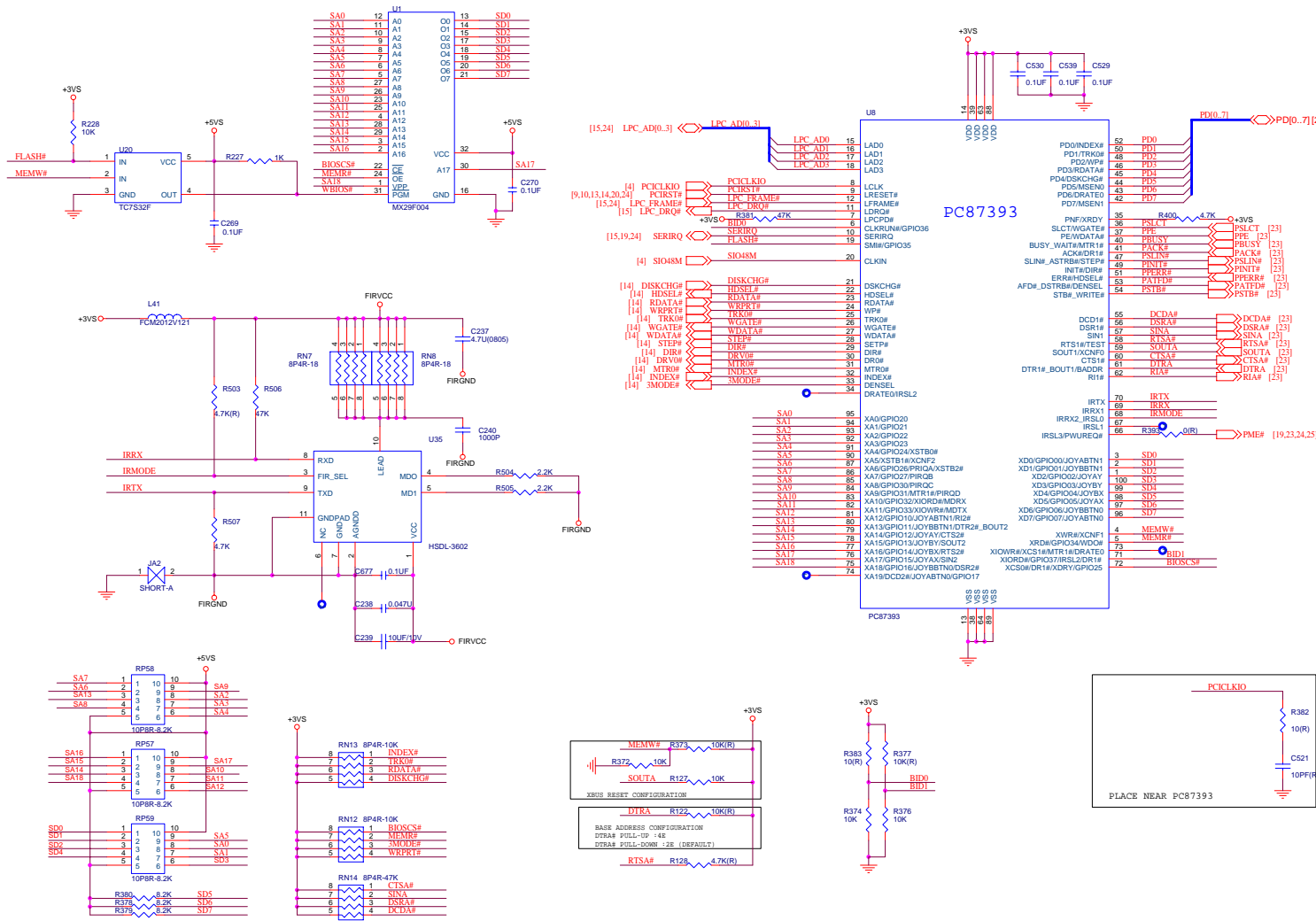

Sheet 22 of 35
LPC S/I/O

B.Schematic Diagrams

LPT/COM Port

Sheet 23 of 35
LPT/COM Port

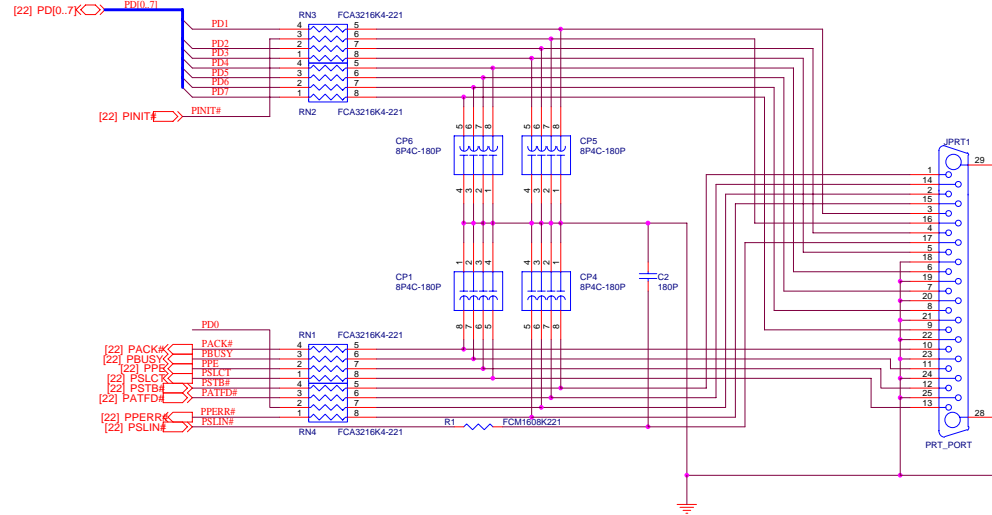
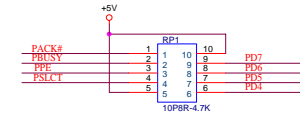
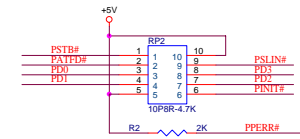
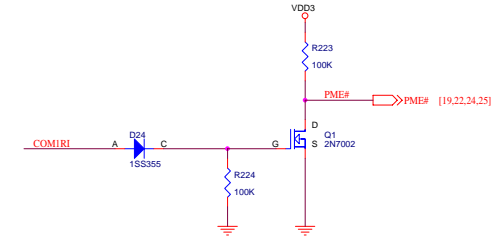
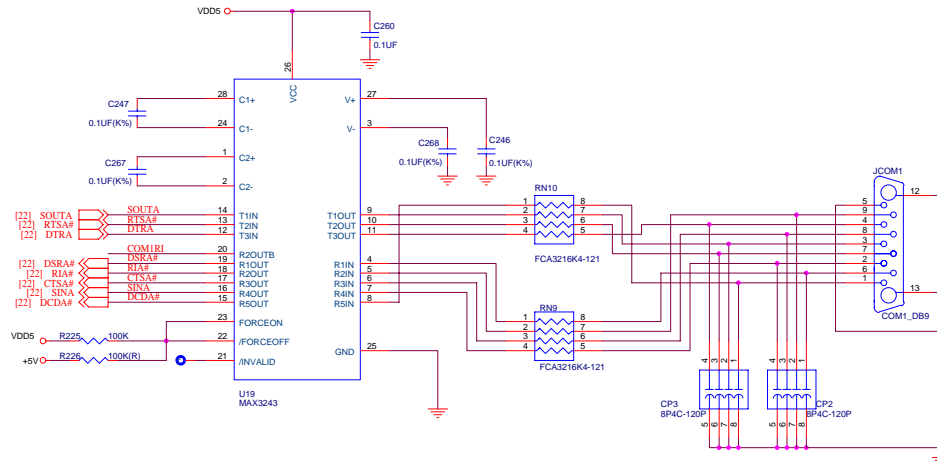

LPC H8

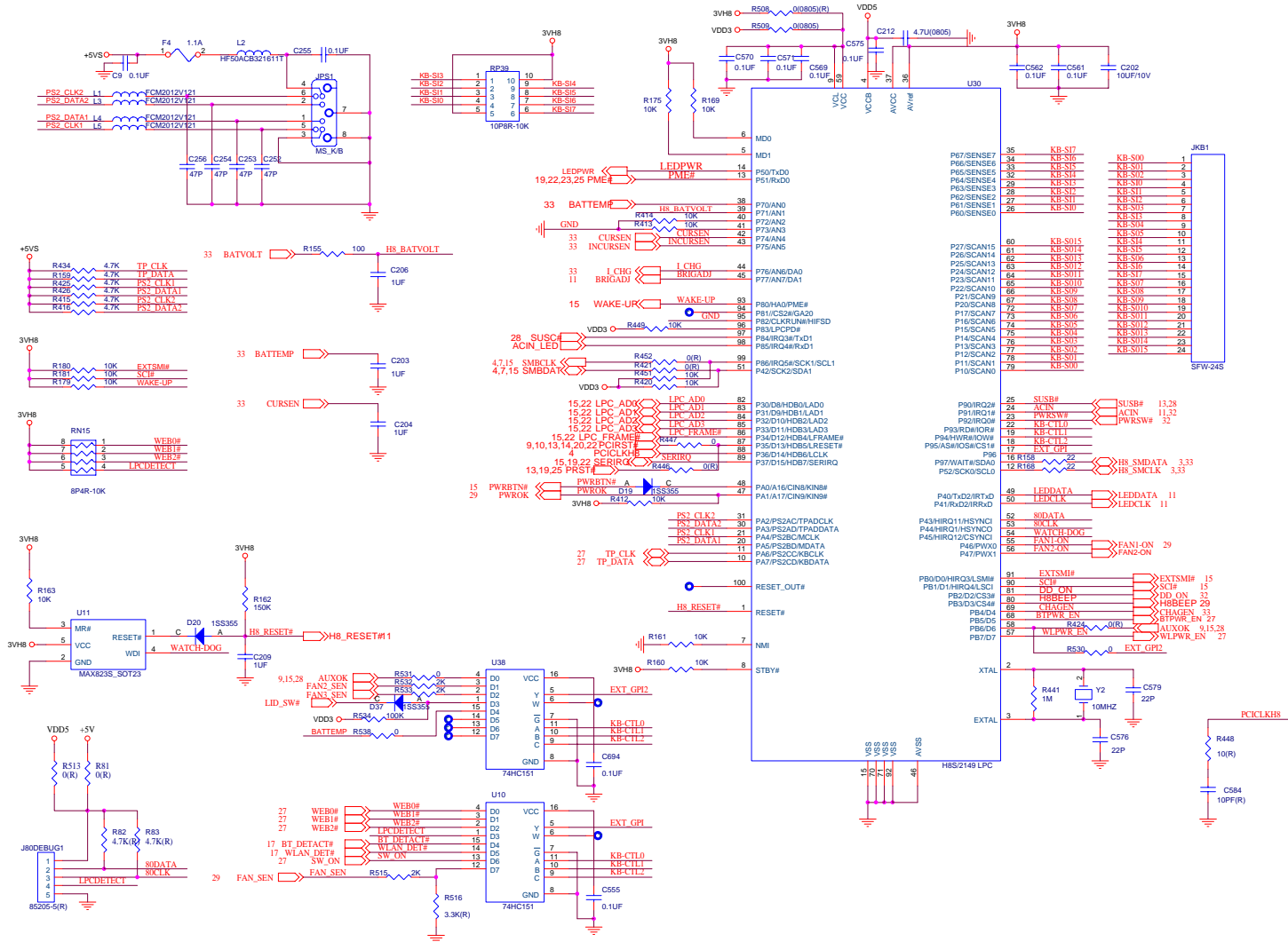

Sheet 24 of 35
LPC H8

B.Schematic Diagrams

Schematic Diagrams

LAN RTL8100BL

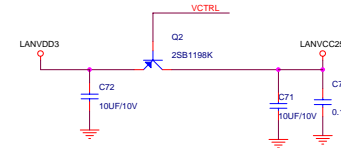
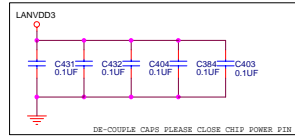

*For RTL8100C application, all bead must be rated 300mA/100ohm@100Khz
The maximum voltage drop when on should be less than 0.3V

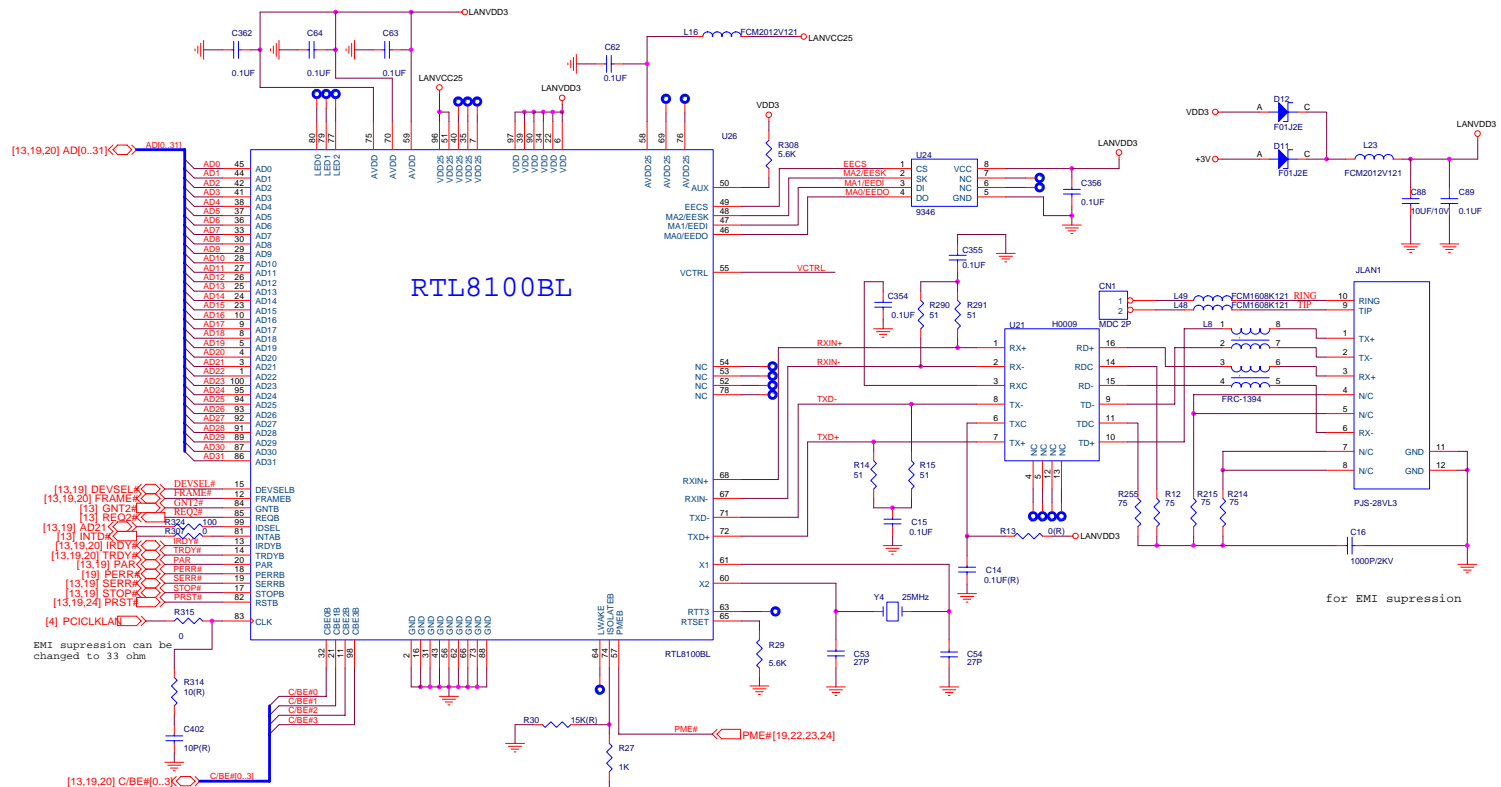

for EMI suppresion

B.Schematic Diagrams

Sheet 25 of 35
LAN RTL8100BL

Audio Codec ALC201A

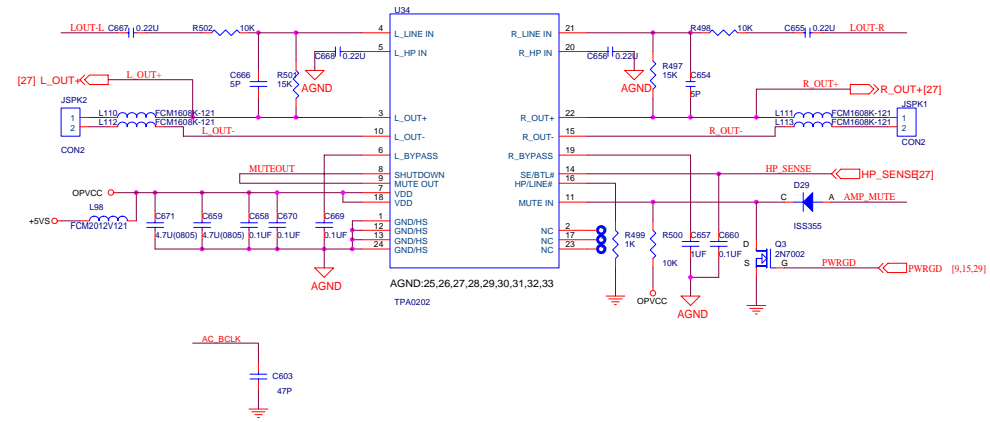
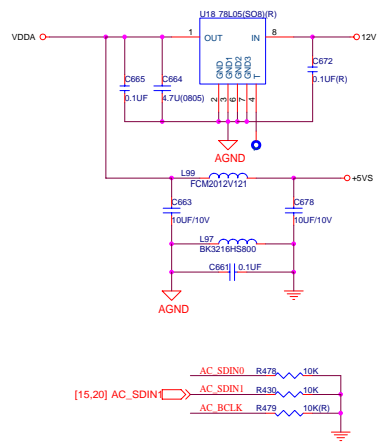
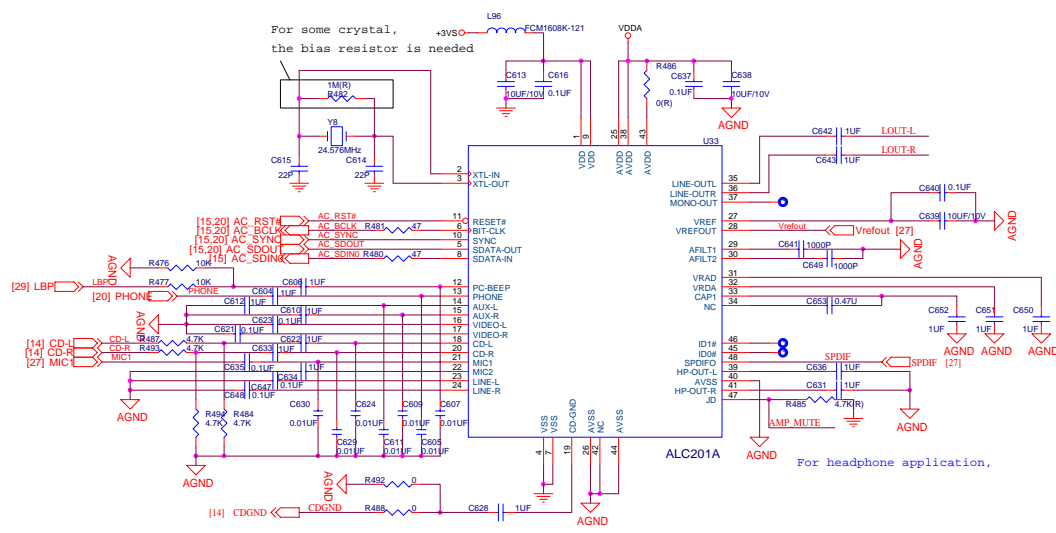

Sheet 26 of 35
 Audio Codec
 ALC201A

B. Schematic Diagrams

Audio Out & Off Board Connectors

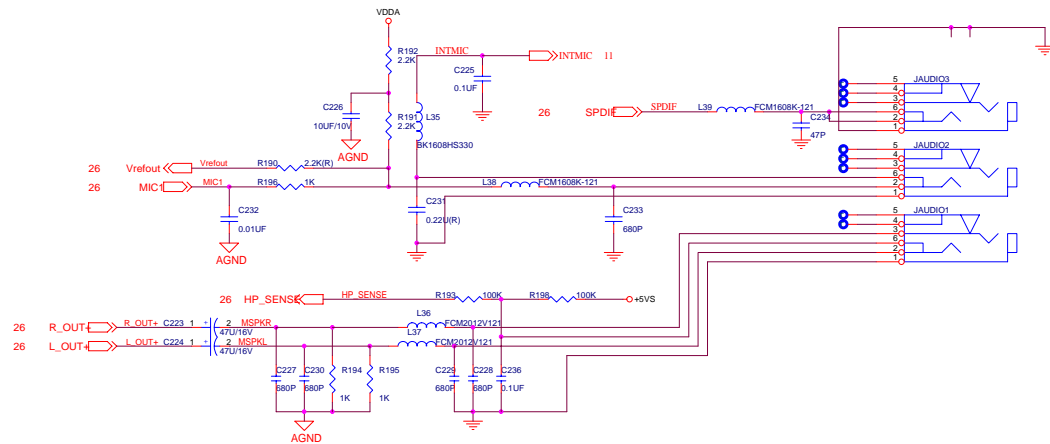

SPDIF OUT
MIC IN
SPEAKER OUT

Sheet 27 of 35
Audio Out & Off
Board Connectors

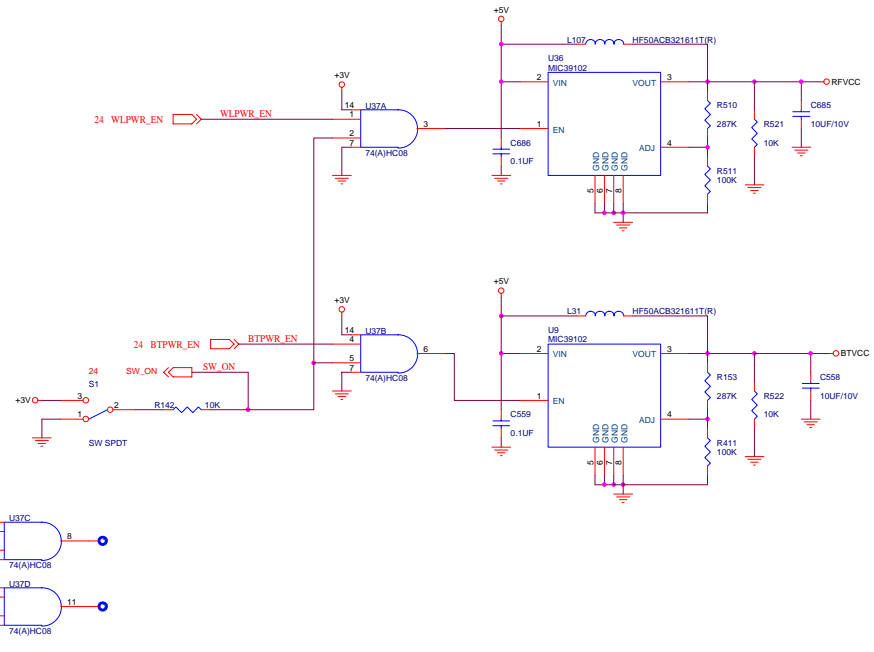
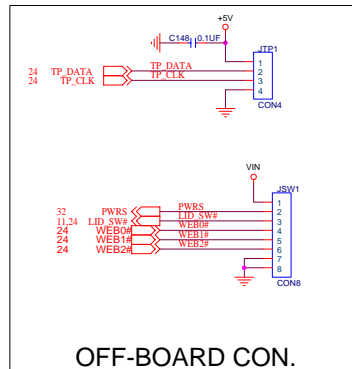

System Power Control

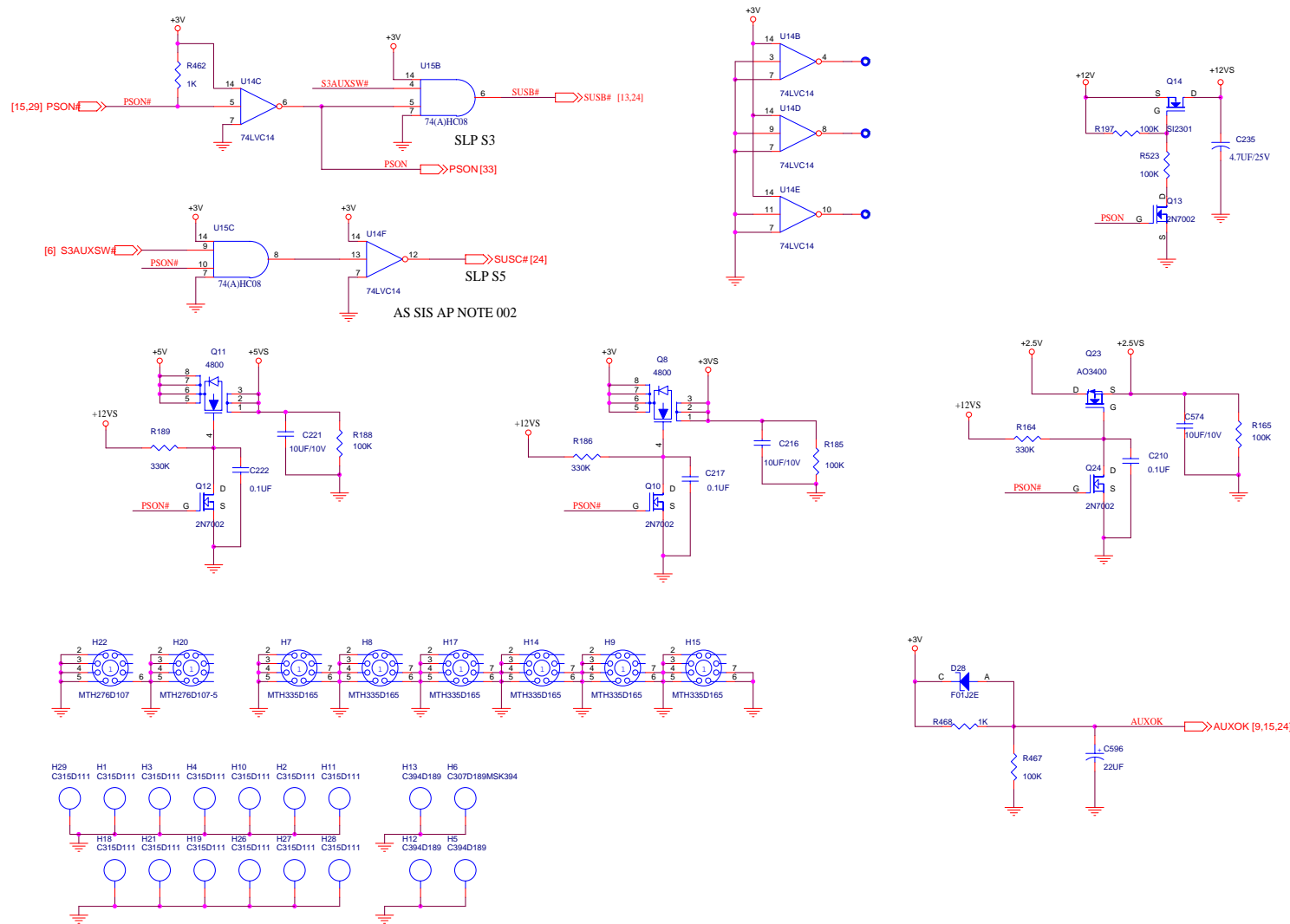

Sheet 28 of 35
System Power
Control

B. Schematic Diagrams

Fan Control and SpeedStep

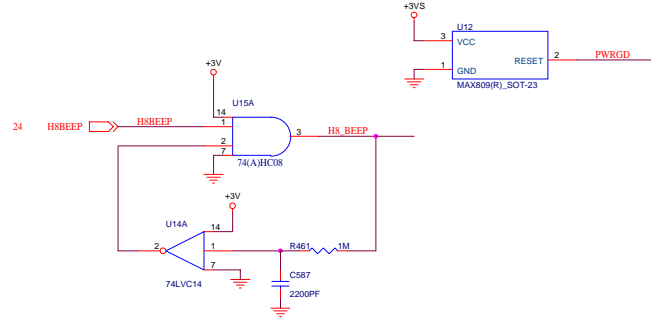
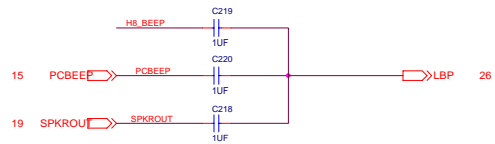
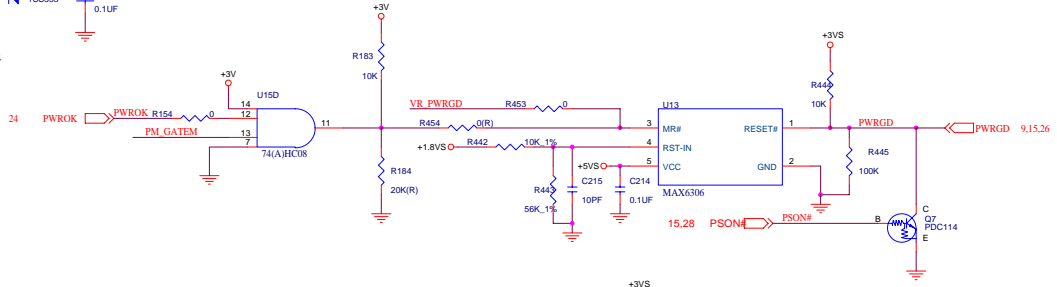
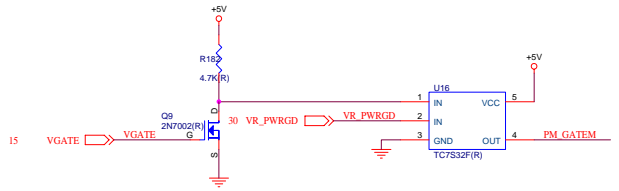
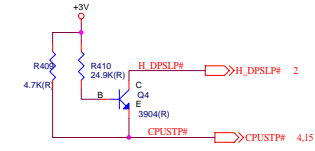
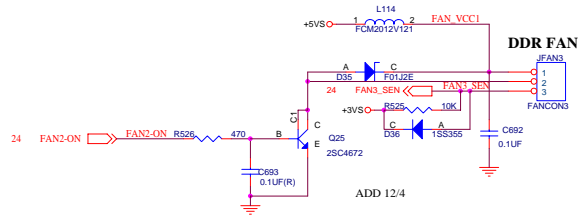
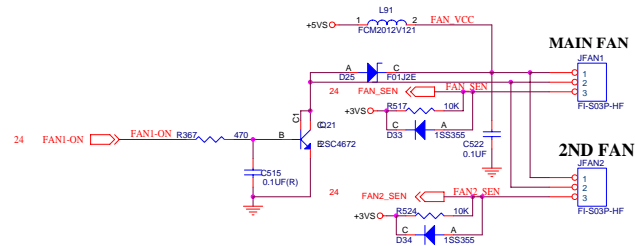

Sheet 29 of 35
Fan Control &
SpeedStep

B.Schematic Diagrams

VCORE

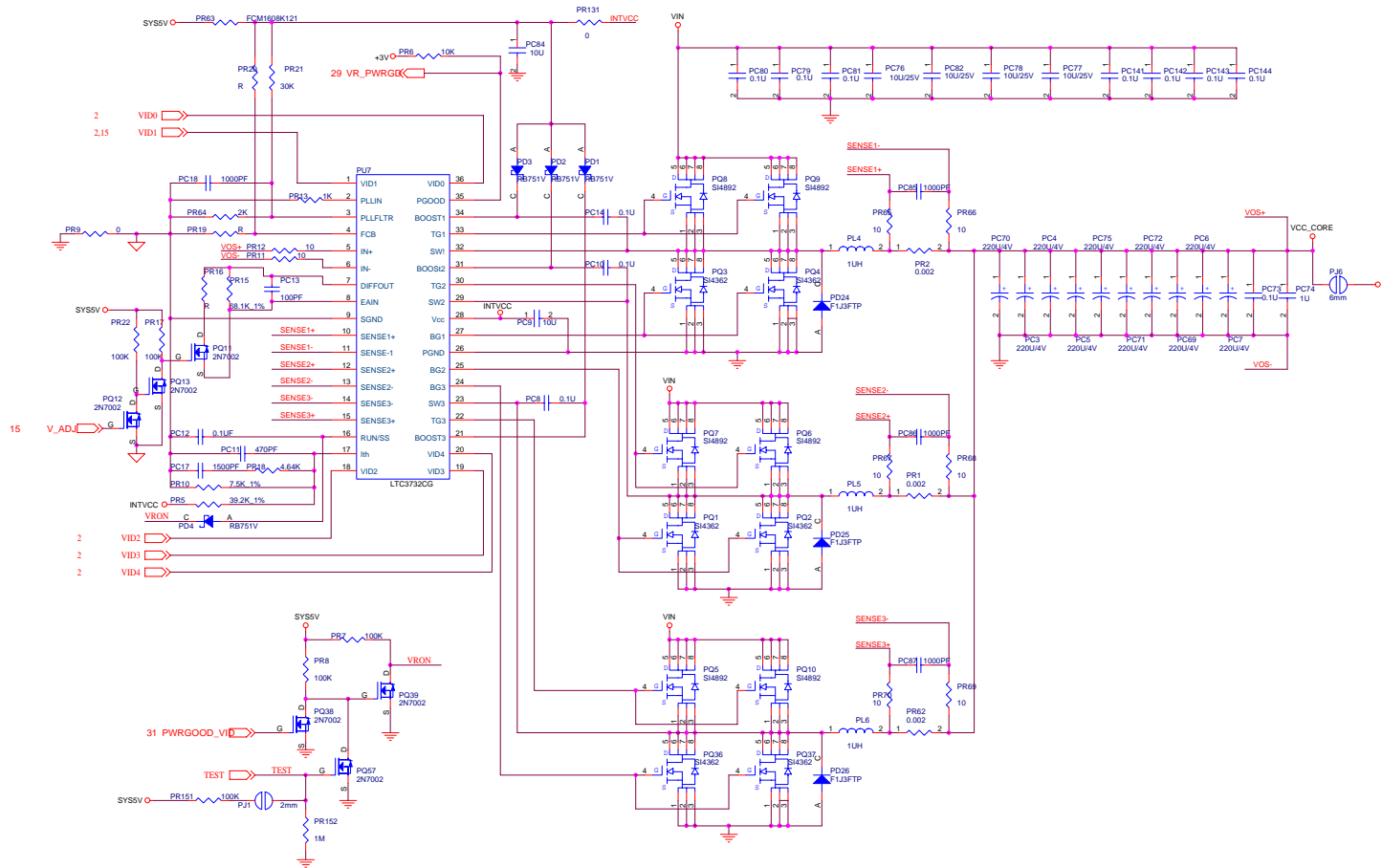

Sheet 30 of 35
VCORE

Schematic Diagrams

DDR Power

Sheet 31 of 35
DDR Power

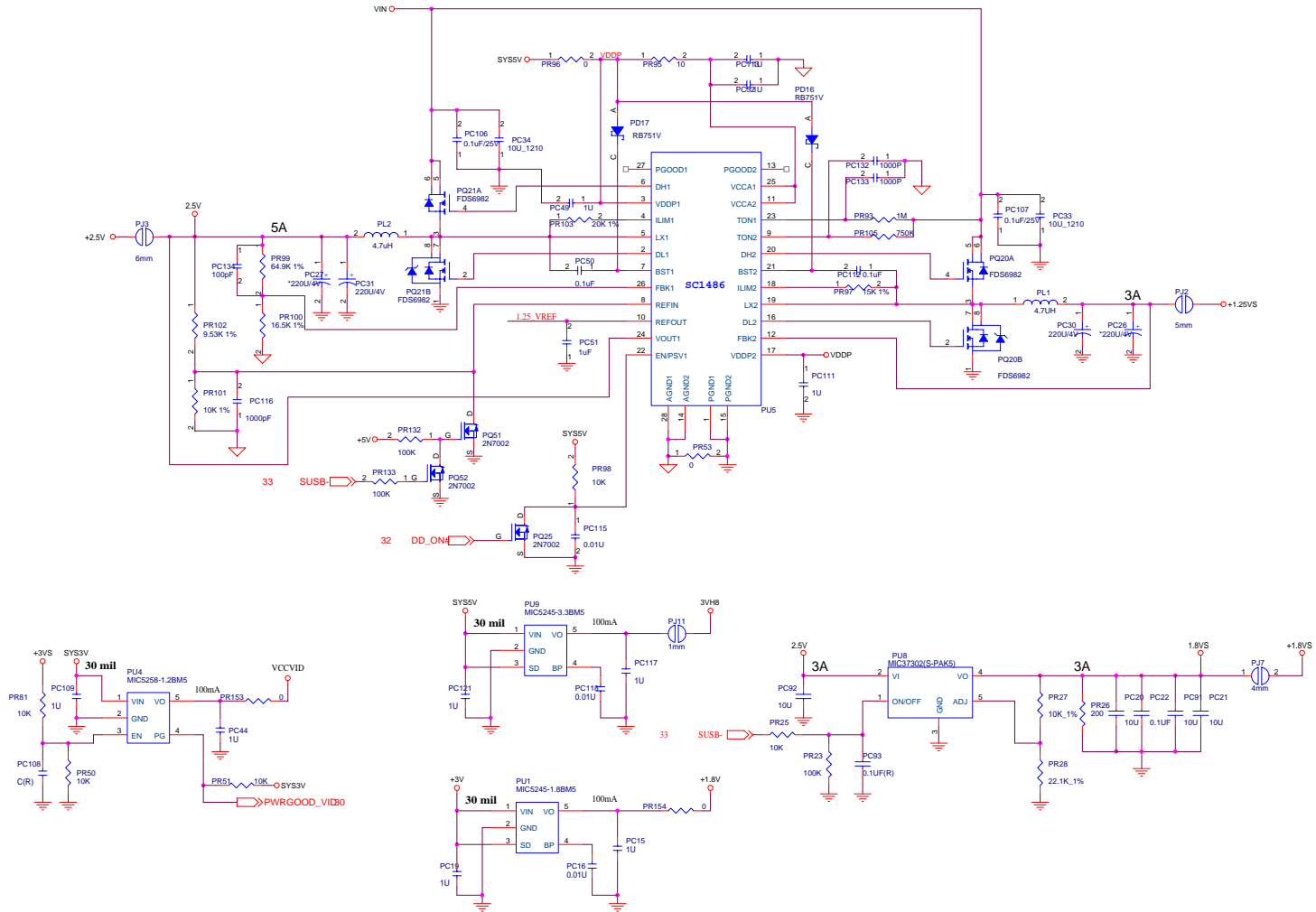

System

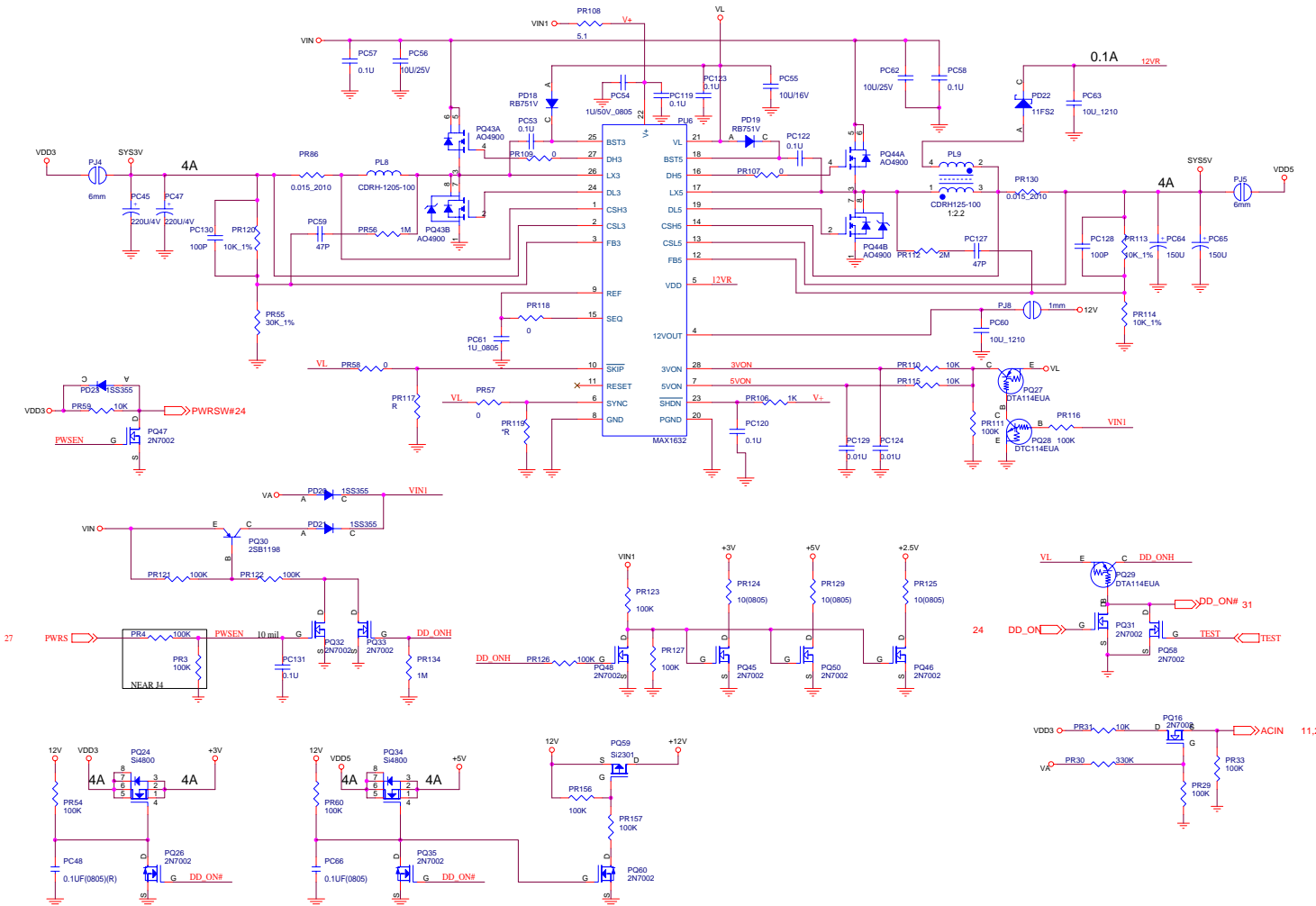

Sheet 32 of 35
System

B. Schematic Diagrams

Charger

Sheet 33 of 35
Charger

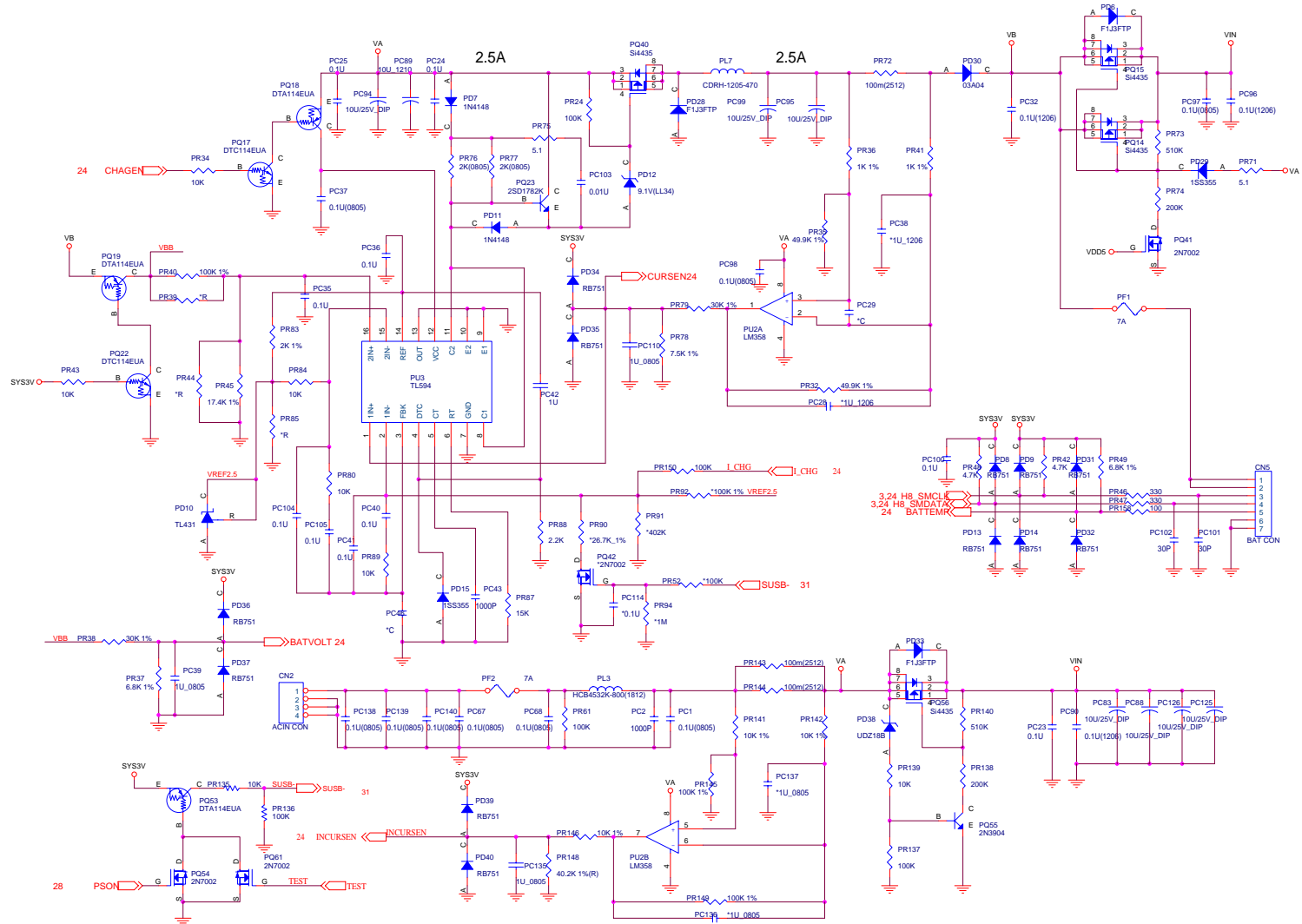

B - 34 Charger (71-D4000-D04)

SW Board and HotKey

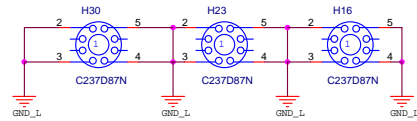
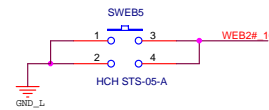
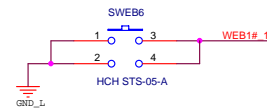
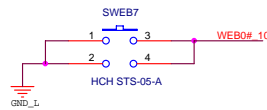
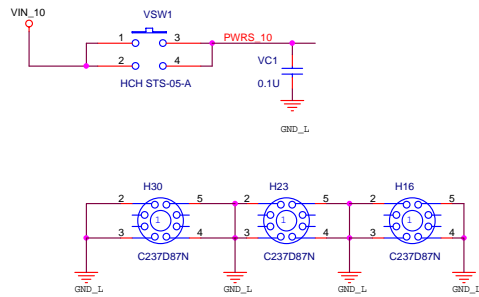
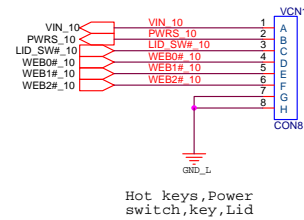
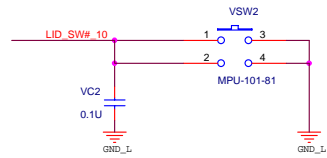

Sheet 34 of 35
SW Board and
HotKey

TouchPad and Switch Board

Sheet 35 of 35
TouchPad and
Switch Board

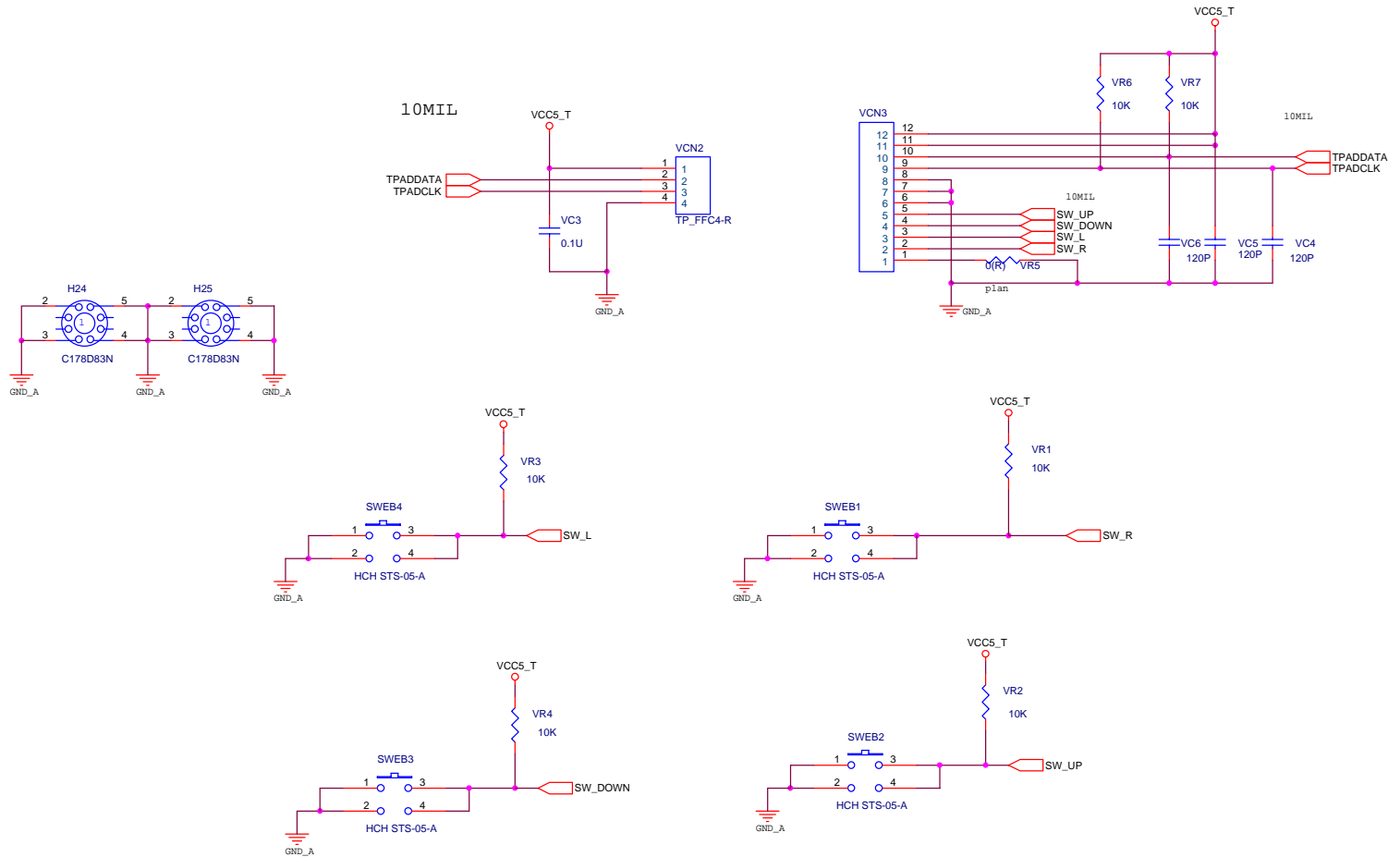

Appendix C: Updating the FLASH ROM BIOS

To update the FLASH ROM BIOS you must:

- Download the BIOS update from the web site.
 - Unzip the files onto a bootable Floppy Disk.
 - Reboot your computer from the FDD.
 - Use the flash tools to update the flash BIOS.
 - Restart the computer booting from the HDD.
1. Using your web browser go to www.clevo.com.tw
 2. Choose **Download** from the menu bar at the top of the page.
 3. In the **Driver** section select the model of your computer (**D400S/D410S Series**) and the driver type (**BIOS**).
 4. Select **GO**.
 5. Click on **D4x0Sxxx.zip** to download the BIOS files (including BIOS refresh tools).

Unzip the file you have just downloaded on to a bootable floppy disk.

(The files you should see on this disk are: Phlash.exe, autoexec.bat, Platform.bin, D4x0Sxxx.ROM & Readme.txt)

1. With the bootable floppy disk containing the BIOS files in your floppy drive, restart the computer.
2. The BIOS refresh process will execute automatically.
3. Reboot the computer and enter the BIOS setup.
4. Exit the BIOS and restore the default settings by choosing “Save and Exit”.

Free Manuals Download Website

<http://myh66.com>

<http://usermanuals.us>

<http://www.somanuals.com>

<http://www.4manuals.cc>

<http://www.manual-lib.com>

<http://www.404manual.com>

<http://www.luxmanual.com>

<http://aubethermostatmanual.com>

Golf course search by state

<http://golfingnear.com>

Email search by domain

<http://emailbydomain.com>

Auto manuals search

<http://auto.somanuals.com>

TV manuals search

<http://tv.somanuals.com>