

SERVICE MANUAL

M740T / M740TU / M760T / M760TU

notebook

Notebook Computer

M740T/M740TU/M760T/M760TU

Service Manual

Notice

The company reserves the right to revise this publication or to change its contents without notice. Information contained herein is for reference only and does not constitute a commitment on the part of the manufacturer or any subsequent vendor. They assume no responsibility or liability for any errors or inaccuracies that may appear in this publication nor are they in anyway responsible for any loss or damage resulting from the use (or misuse) of this publication.

This publication and any accompanying software may not, in whole or in part, be reproduced, translated, transmitted or reduced to any machine readable form without prior consent from the vendor, manufacturer or creators of this publication, except for copies kept by the user for backup purposes.

Brand and product names mentioned in this publication may or may not be copyrights and/or registered trademarks of their respective companies. They are mentioned for identification purposes only and are not intended as an endorsement of that product or its manufacturer.

Version 1.0
June 2008

Trademarks

Intel and **Intel Core** are trademarks of Advanced Micro Devices, Inc.

Windows[®] is a registered trademark of Microsoft Corporation.

Other brand and product names are trademarks and./or registered trademarks of their respective companies.

About this Manual

This manual is intended for service personnel who have completed sufficient training to undertake the maintenance and inspection of personal computers.

It is organized to allow you to look up basic information for servicing and/or upgrading components of the *M740T/M740TU/M760T/M760TU* series notebook PC.

The following information is included:

Chapter 1, Introduction, provides general information about the location of system elements and their specifications.

Chapter 2, Disassembly, provides step-by-step instructions for disassembling parts and subsystems and how to upgrade elements of the system.

Appendix A, Part Lists

Appendix B, Schematic Diagrams

IMPORTANT SAFETY INSTRUCTIONS

Follow basic safety precautions, including those listed below, to reduce the risk of fire, electric shock and injury to persons when using any electrical equipment:

1. Do not use this product near water, for example near a bath tub, wash bowl, kitchen sink or laundry tub, in a wet basement or near a swimming pool.
2. Avoid using a telephone (other than a cordless type) during an electrical storm. There may be a remote risk of electrical shock from lightning.
3. Do not use the telephone to report a gas leak in the vicinity of the leak.
4. Use only the power cord and batteries indicated in this manual. Do not dispose of batteries in a fire. They may explode. Check with local codes for possible special disposal instructions.
5. This product is intended to be supplied by a Listed Power Unit with an AC Input of 100 - 240V, 50 - 60Hz, DC Output of 19V, 3.42A (**65** Watts) minimum AC/DC Adapter for **M740T/M760T** computers, **OR** 19V, 4.74A (**90** Watts) minimum AC/DC Adapter for **M740TU/M760TU** computers.

CAUTION

Always disconnect all telephone lines from the wall outlet before servicing or disassembling this equipment.

**TO REDUCE THE RISK OF FIRE, USE ONLY NO. 26 AWG OR LARGER,
TELECOMMUNICATION LINE CORD**

This Computer's Optical Device is a Laser Class 1 Product

Instructions for Care and Operation

The notebook computer is quite rugged, but it can be damaged. To prevent this, follow these suggestions:

1. **Don't drop it, or expose it to shock.** If the computer falls, the case and the components could be damaged.



2. **Keep it dry, and don't overheat it.** Keep the computer and power supply away from any kind of heating element. This is an electrical appliance. If water or any other liquid gets into it, the computer could be badly damaged.

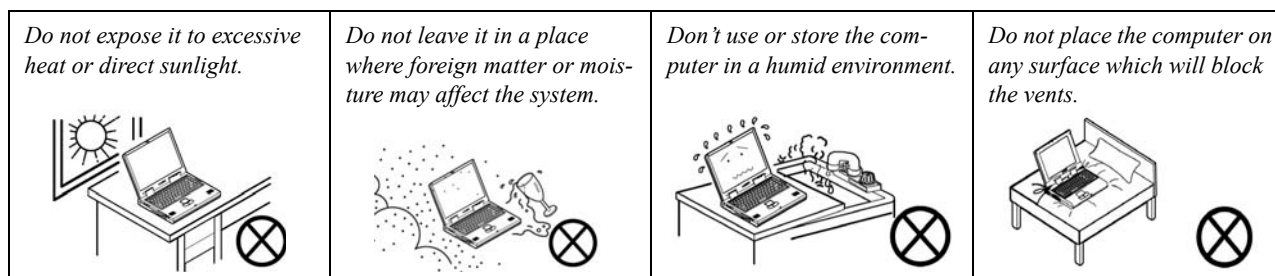

3. **Follow the proper working procedures for the computer.** Shut the computer down properly and don't forget to save your work. Remember to periodically save your data as data may be lost if the battery is depleted.

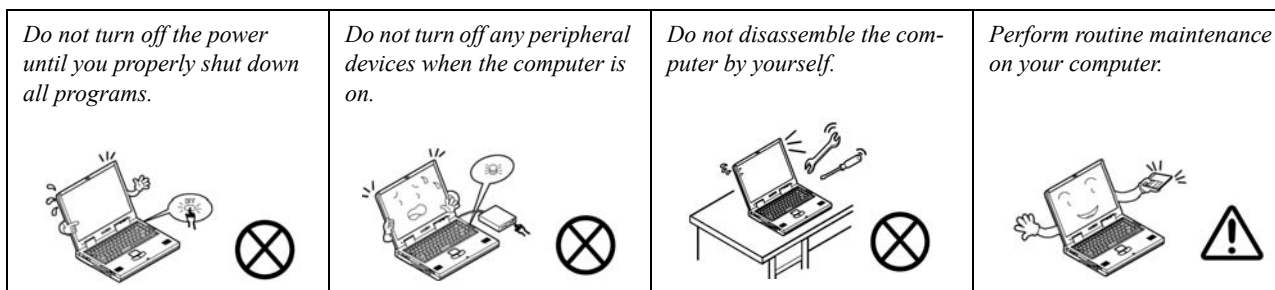

4. **Avoid interference.** Keep the computer away from high capacity transformers, electric motors, and other strong magnetic fields. These can hinder proper performance and damage your data.
5. **Take care when using peripheral devices.**

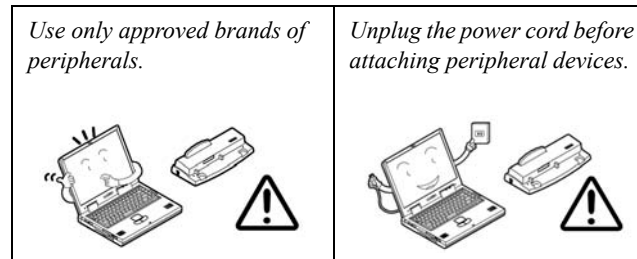

Power Safety

The computer has specific power requirements:

- Only use a power adapter approved for use with this computer.
- Your AC adapter may be designed for international travel but it still requires a steady, uninterrupted power supply. If you are unsure of your local power specifications, consult your service representative or local power company.
- The power adapter may have either a 2-prong or a 3-prong grounded plug. The third prong is an important safety feature; do not defeat its purpose. If you do not have access to a compatible outlet, have a qualified electrician install one.
- When you want to unplug the power cord, be sure to disconnect it by the plug head, not by its wire.
- Make sure the socket and any extension cord(s) you use can support the total current load of all the connected devices.
- Before cleaning the computer, make sure it is disconnected from any external power supplies.

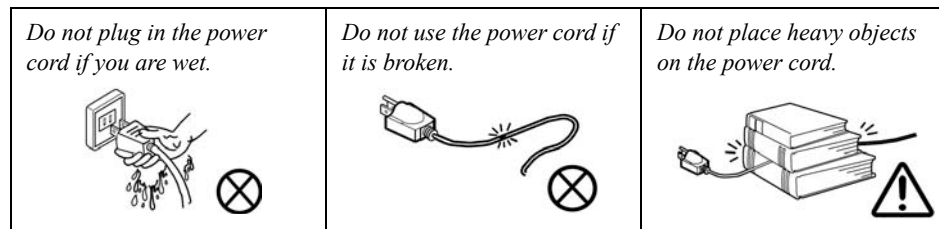

Power Safety Warning

Before you undertake any upgrade procedures, make sure that you have turned off the power, and disconnected all peripherals and cables (including telephone lines). It is advisable to also remove your battery in order to prevent accidentally turning the machine on.

Battery Precautions

- Only use batteries designed for this computer. The wrong battery type may explode, leak or damage the computer.
- Do not remove any batteries from the computer while it is powered on.
- Do not continue to use a battery that has been dropped, or that appears damaged (e.g. bent or twisted) in any way. Even if the computer continues to work with a damaged battery in place, it may cause circuit damage, which may possibly result in fire.
- Recharge the batteries using the notebook's system. Incorrect recharging may make the battery explode.
- Do not try to repair a battery pack. Refer any battery pack repair or replacement to your service representative or qualified service personnel.
- Keep children away from, and promptly dispose of a damaged battery. Always dispose of batteries carefully. Batteries may explode or leak if exposed to fire, or improperly handled or discarded.
- Keep the battery away from metal appliances.
- Affix tape to the battery contacts before disposing of the battery.
- Do not touch the battery contacts with your hands or metal objects.



Battery Disposal

The product that you have purchased contains a rechargeable battery. The battery is recyclable. At the end of its useful life, under various state and local laws, it may be illegal to dispose of this battery into the municipal waste stream. Check with your local solid waste officials for details in your area for recycling options or proper disposal.

Caution

Danger of explosion if battery is incorrectly replaced. Replace only with the same or equivalent type recommended by the manufacturer. Discard used battery according to the manufacturer's instructions.

Related Documents

You may also need to consult the following manual for additional information:

User's Manual on CD

This describes the notebook PC's features and the procedures for operating the computer and its ROM-based setup program. It also describes the installation and operation of the utility programs provided with the notebook PC.

Contents

Introduction	1-1	Top with Fingerprint (M740T/M740TU)	A-3
Overview	1-1	Top without Fingerprint (M740T/M740TU)	A-4
System Specifications	1-2	Bottom (M740T)	A-5
External Locator - Top View with LCD Panel Open	1-6	Bottom (M740TU)	A-6
External Locator - Front & Right side Views	1-7	LCD (M740T/M740TU)	A-7
External Locator - Left Side & Rear View	1-8	HDD (M740T/M740TU)	A-8
External Locator - Bottom View	1-9	COMBO (M740T/M740TU)	A-9
Mainboard Overview - Top (Key Parts)	1-10	DVD-Dual Drive (M740T/M740TU)	A-10
Mainboard Overview - Bottom (Key Parts)	1-11	Top with Fingerprint (M760T/M760TU)	A-11
Mainboard Overview - Top (Connectors)	1-12	Top without Fingerprint (M760T/M760TU)	A-12
Mainboard Overview - Bottom (Connectors)	1-13	Bottom (M760T)	A-13
Disassembly	2-1	Bottom (M760TU)	A-14
Overview	2-1	LCD (M760T/M760TU)	A-15
Maintenance Tools	2-2	HDD (M760T/M760TU)	A-16
Connections	2-2	COMBO (M760T/M760TU)	A-17
Maintenance Precautions	2-3	DVD-Dual Drive (M760T/M760TU)	A-18
Disassembly Steps	2-4	Schematic Diagrams.....	B-1
Removing the Battery	2-5	System Block Diagram	B-2
Removing the Hard Disk Drive	2-6	Clock Generator	B-3
Removing the Optical (CD/DVD) Device	2-9	Penryn (Socket-P) CPU 1/2	B-4
Removing the System Memory (RAM)	2-11	Penryn (Socket-P) CPU 2/2	B-5
Removing the Inverter Board	2-13	CANTIGA 1/7, Host	B-6
Removing and Installing the Processor	2-14	CANTIGA 2/7, Graphics	B-7
Removing the Wireless LAN Module	2-17	CANTIGA 3/7	B-8
Removing the Bluetooth Module	2-18	CANTIGA 4/7	B-9
Removing the Keyboard	2-19	CANTIGA 5/7	B-10
Removing the Modem	2-20	CANTIGA 6/7	B-11
Part Lists	A-1	CANTIGA 7/7	B-12
Part List Illustration Location	A-2	DDRII SO-DIMM - 0	B-13
		DDRII SO-DIMM - 1	B-14

Preface

Panel, Inverter, CRT	B-15	Multi Function Board	B-47
VGA NB9M-1	B-16	Audio Board	B-48
VGA NB9M-2	B-17	Finger Sensor Board for M76	B-49
VGA NB9M-3	B-18	Power Switch Board for M74	B-50
VGA NB9M-4	B-19	FingerPrint Board for M74	B-51
VGA NB9M-5	B-20	Power Switch Board for M76	B-52
VGA NB9M-6	B-21		
VGA NB9M-7	B-22		
ICH9M 1/4, SATA	B-23		
ICH9M 2/4, PCI, USB	B-24		
ICH9M 3/4	B-25		
ICH9M 4/4	B-26		
New Card, Mini PCIE	B-27		
3G, Powergood	B-28		
USB, Fan, TP, FP, Multi CON	B-29		
Card Reader	B-30		
SATA ODD, LED, Hotkey, LID SW	B-31		
PCI-E LAN RTL8111C	B-32		
Audio Codec ALC662	B-33		
Audio AMP	B-34		
KBC-ITE IT8512E	B-35		
5VS, 3VS, 3.3VM, 1.05VS, VIN1	B-36		
Power 3.3V/5V	B-37		
Power 1.5VS/1.05VS	B-38		
Power 1.8V/0.9V	B-39		
Power GPU/NVVDD	B-40		
AC-IN, Charger	B-41		
VCORE	B-42		
NVVDD	B-43		
HDMI	B-44		
External ODD Board for M76	B-45		
Click & Finger Board for M76	B-46		

Chapter 1: Introduction

Overview

This manual covers the information you need to service or upgrade the *M740T/M740TU/M760T/M760TU* series notebook computer. Information about operating the computer (e.g. getting started, and the *Setup* utility) is in the *User's Manual*. Information about drivers (e.g. VGA & audio) is also found in *User's Manual*. That manual is shipped with the computer.

Operating systems (e.g. *Windows XP*, *Windows Vista*, etc.) have their own manuals as do application software (e.g. word processing and database programs). If you have questions about those programs, you should consult those manuals.

The *M740T/M740TU/M760T/M760TU* series notebook is designed to be upgradeable. See ***“Disassembly” on page 2 - 1*** for a detailed description of the upgrade procedures for each specific component. Please note the warning and safety information indicated by the “” symbol.

The balance of this chapter reviews the computer's technical specifications and features.

System Specifications

Feature	Specification	
Processor	Intel® Core™2 Duo Processor (478-pin) Micro-FC-PGA Package, Socket P TDP: 35W T9400/ T9600	45nm (45 Nanometer) Process Technology 6MB On-die L2 Cache & 1066MHz FSB 2.53/ 2.8 GHz
	Intel® Core™2 Duo Processor (478-pin) Micro-FC-PGA Package, Socket P TDP: 25W P9500	45nm (45 Nanometer) Process Technology 6MB On-die L2 Cache & 1066MHz FSB 2.53 GHz
	Intel® Core™2 Duo Processor (478-pin) Micro-FC-PGA Package, Socket P TDP: 25W P8400/ P8600	45nm (45 Nanometer) Process Technology 3MB On-die L2 Cache & 1066MHz FSB 2.26/ 2.40 GHz
Core Logic	<u>M740T/M760T:</u> Intel(R) GM45 + ICH9M Chipset	<u>M740TU/M760TU:</u> Intel(R) PM45 + ICH9M Chipset
LCD	<u>M740T/M740TU:</u> 14.1" WXGA (1280*800)/ WXGA+ (1440*900) Glare Type TFT LCD	<u>M760T/M760TU:</u> 15.4" WXGA (1280*800)/ WXGA+ (1440*900)/ WSXGA+ (1680*1050) Glare Type TFT LCD
Video Adapter	<u>M740T/M760T:</u> Intel GM45 Integrated Video High Preference 3D/2D Graphic Accelerator Supports Dynamic Video Memory Technology DVMT (up to 256MB dynamically allocated from system memory where needed) Supports DirectX10	<u>M740TU/M760TU:</u> nVIDIA GeForce 9300M GS Discrete Graphics On-Board 256MB of GDDR2 Video Memory On-Board TurboCache™ Supporting Total Graphics Memory up to 512MB (depending on system memory) Supports DirectX 10 Supports PCIE * 16 Supports HDCP
Memory	64-bit Wide DDRII (DDR2) Data Channel Supports Dual Channel DDR2 SDRAM Two 200 Pin SO-DIMM Sockets Supporting DDRII (DDR2) 667MHz/ 800MHz Memory Expandable up to 4GB (1024MB/ 2048MB DDRII Modules)	

Feature	Specification	
Security	Security (Kensington® Type) Lock Slot Fingerprint ID Reader Module (Factory Option)	BIOS Password
BIOS	One 32Mb SPI Flash ROM	Phoenix™ BIOS
Storage	One Changeable 12.7mm(h) SATA Optical Device (CD/DVD) Type Drive (see <i>“Optional” on page 1 - 5</i>) Easy Changeable 2.5" 9.5 mm (h) SATA (Serial) HDD	
Audio	Intel® High Definition Audio (HDA) Interface 3D Enhanced Sound System Sound-Blaster PRO™ Compatible	S/PDIF Digital Output 2 * Built-In Speakers (1W, 8Ω) Built-In Microphone
Keyboard & Pointing Device	Winkey Keyboard	Built-In TouchPad with Scrolling Function
Interface	Three USB 2.0 Ports One HDMI-Out Port (High-Definition Multimedia Interface) One Headphone-Out Jack One Microphone-In Jack One S/PDIF-Out Jack	One eSATA Port (supported in <i>Windows Vista</i> only): AHCI mode supports hot swapping IDE mode does not support hot swapping One RJ-11 Modem Jack One RJ-45 LAN Jack One DC-In Jack One External Monitor Port
Card Reader	Embedded 7-in-1 Card Reader (MS/ MS Pro/ SD/ Mini SD/ MMC/ RS MMC/ MS Duo) Note: MS Duo/ Mini SD/ RS MMC Cards require a PC adapter	
ExpressCard Slot	One ExpressCard/34(54) Slot	
Mini-Card Slots	One Mini-Card Slot for Wireless LAN Module One Mini-Card Slot for 3.5G Module	

Introduction

Feature	Specification	
Communication  UMTS Modes Note that UMTS modes CAN NOT be used in North America.	Built-In 56K MDC Modem, V.90 & V.92 Compliant Built-In Gigabit Ethernet LAN Bluetooth 2.0 + EDR (Enhanced Data Rate) Module (Factory Option) 1.3M or 2.0M Pixel USB PC Camera Module (Factory Option) Wireless LAN Module: Intel® WiFi Link 5300 Series (3*3 - 802.11a/g/n) Wireless LAN Mini-Card Module (Option) Intel® WiFi Link 5100 Series (1*2 - 802.11a/g/n) Wireless LAN Mini-Card Module (Option) 3.5G Module: UMTS/HSPDA-based 3.5G Module with Mini-Card Interface (Factory Option) Quad-band GSM/GPRS (850 MHz, 900 MHz, 1800 MHz, 1900 MHz) UMTS WCDMA FDD (2100 MHz)	
Power Management	Supports ACPI 3.0 Supports Wake on LAN	Supports Resume from Modem Ring
Power	M740T/M760T: Full Range AC/DC Adapter AC input 100 - 240V, 50 - 60Hz, DC Output 19V, 3.42A (65 Watts)	M740TU/M760TU: Full Range AC/DC Adapter AC input 100 - 240V, 50 - 60Hz, DC Output 19V, 4.74A (90 Watts)
Battery	6 Cell Smart Lithium-Ion Battery Pack, 4000mAH OR 4400mAH 9 Cell Smart Lithium-Ion Battery Pack, 7200mAH (Option)	
Environmental Spec	Temperature Operating: 5°C - 35°C Non-Operating: -20°C - 60°C	Relative Humidity Operating: 20% - 80% Non-Operating: 10% - 90%
Dimensions & Weight	M740T/M740TU: 336mm (w) * 250mm (d) * 24.8-35.7mm (h) Around 2.3 kg With 6 Cell Battery	M760T/M760TU: 359mm (w) * 268mm (d) * 24.8-37mm (h) 2.6 kg With 6 Cell Battery

1 - 4 System Specifications

Feature	Specification	
Optional	<p>Optical Drive Module Options: Combo/ DVD-Dual (Super Multi) Device Module</p> <p>Wireless LAN Module: Intel® WiFi Link 5300/5100 Series (3*3/1*2 - 802.11a/g/n) Wireless LAN Mini-Card Module</p> <p>9 Cell Smart Lithium-Ion Battery Pack</p> <p>1.3M or 2.0M Pixel USB PC Camera Module (Factory Option)</p> <p>Fingerprint ID Reader Module (Factory Option)</p>	<p>Bluetooth 2.0 + EDR (Enhanced Data Rate) Module (Factory Option)</p> <p>UMTS/HSPDA-based 3.5G Module with Mini-Card Interface (Factory Option) Quad-band GSM/GPRS (850 MHz, 900 MHz, 1800 MHz, 1900 MHz) UMTS WCDMA FDD (2100 MHz)</p> <div data-bbox="1115 513 1653 734" style="border: 2px solid red; border-radius: 15px; padding: 10px; text-align: center;">  UMTS Modes Note that UMTS modes CAN NOT be used in North America. </div>

Introduction

External Locator - Top View with LCD Panel Open

Figure 1
Top View

1. Optional Built-In PC Camera
2. LCD
3. Speakers
4. Power Button
5. Hot Key Buttons
6. Keyboard
7. Built-In Microphone
8. Touchpad & Buttons
9. Fingerprint Module (Optional)
10. LED Indicators

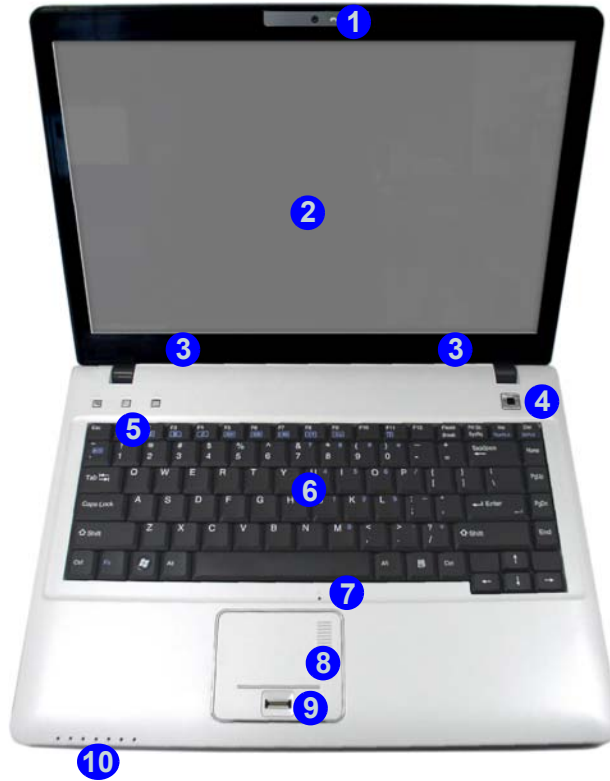

M740T/M740TU



M760T/M760TU



External Locator - Front & Right side Views



Figure 2

Front Views

1. LED Power & Communication Indicators



Figure 3

Right Side Views

1. S/PDIF-Out Jack
2. Microphone-In Jack
3. Headphone-Out Jack
4. USB 2.0 Port
5. Optical Device Drive Bay
6. RJ-11 Phone Jack
7. Security Lock Slot

Introduction

External Locator - Left Side & Rear View

Figure 4
Left Side View

1. DC-In Jack
2. External Monitor Port
3. RJ-45 LAN Jack
4. e-SATA Port
5. HDMI-Out Port
6. Vent/Fan Intake/Outlet
7. 2 * USB 2.0 Ports
8. ExpressCard Slot
9. 7-in-1 Card Reader



Figure 5
Rear View

1. Battery

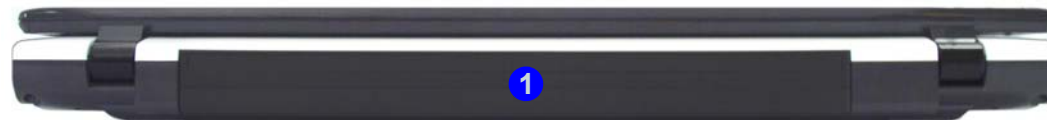

1 - 8 External Locator - Left Side & Rear View

External Locator - Bottom View

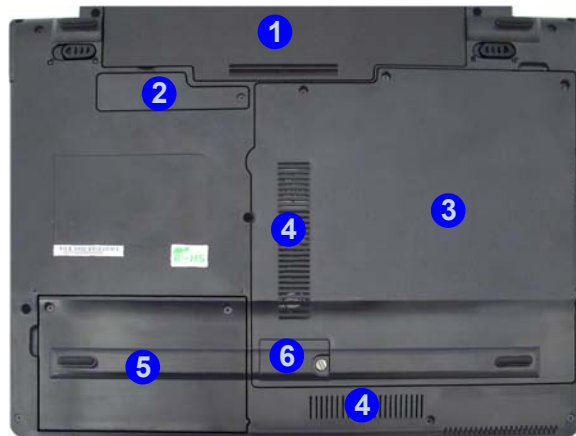

M740T/M740TU

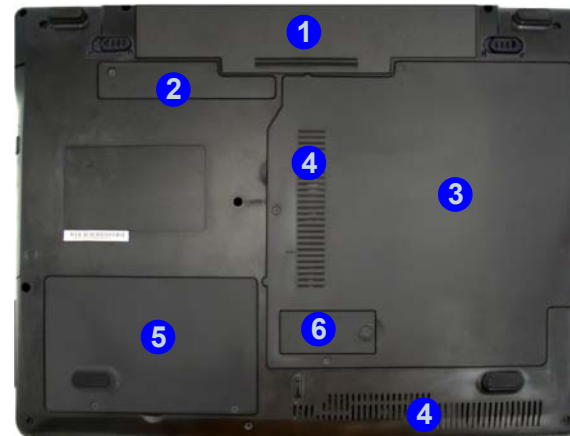

M760T/M760TU

Figure 6
Bottom View

1. Battery
2. Bluetooth Module Cover
3. RAM & CPU Bay Cover
4. Vent/Fan Intake/Outlet
5. Hard Disk Bay Cover
6. 3.5G USIM Card Location



Overheating

To prevent your computer from overheating make sure nothing blocks the vent/fan intakes while the computer is in use.

Introduction

Figure 7
**Mainboard Top
Key Parts**

1. Transformer
2. VT6103L
3. ExpressCard
Connector
4. ENE MR510
5. KBC ITE IT8512E

Mainboard Overview - Top (Key Parts)

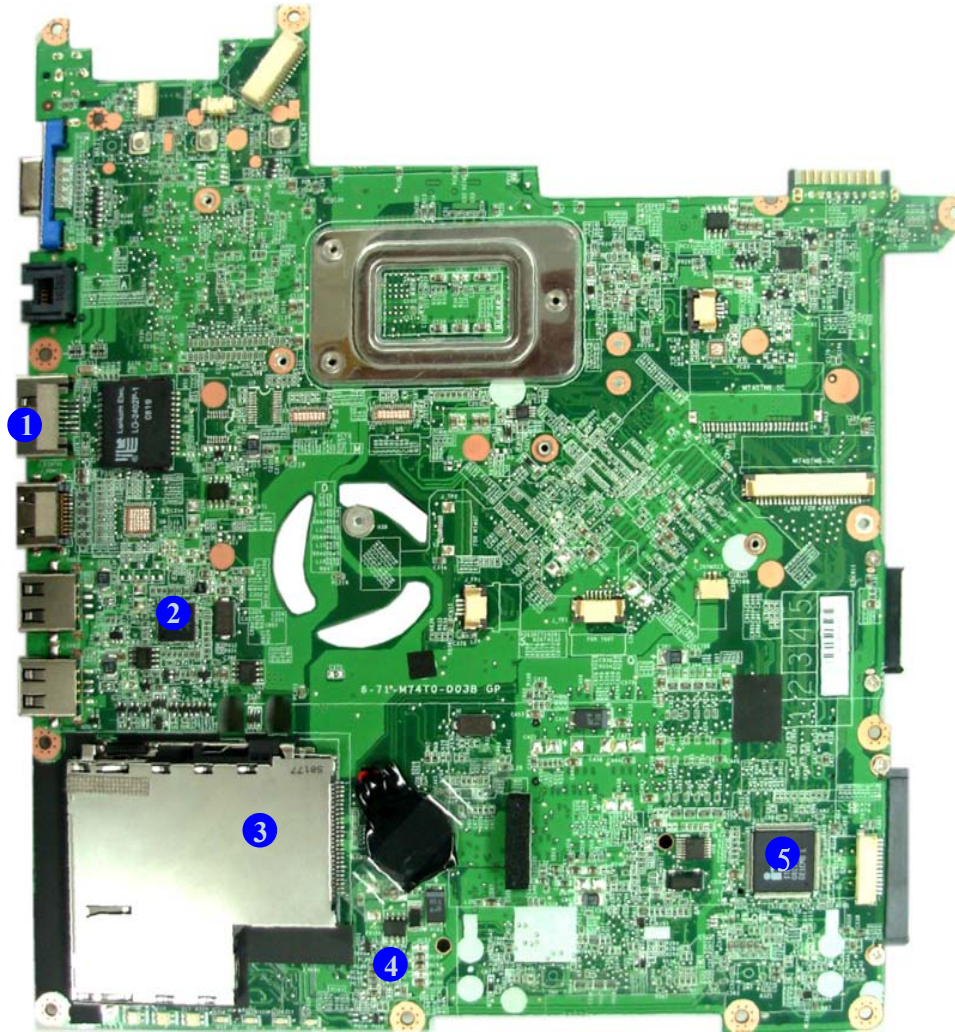

Mainboard Overview - Bottom (Key Parts)

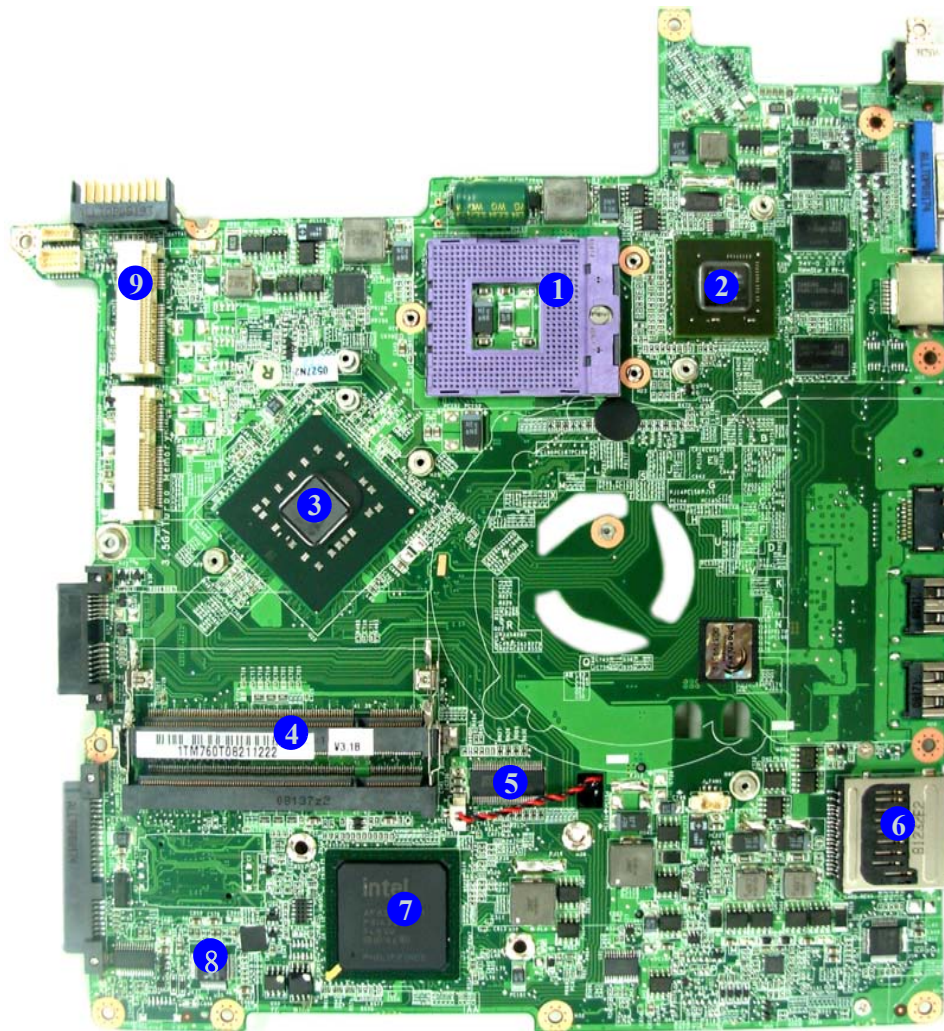

Figure 8
**Mainboard Bottom
Key Parts**

1. CPU Socket (no CPU installed)
2. VGA Chip
3. North Bridge
4. Memory Slots
DDR2 SO-DIMM
5. ICS
6. Card Reader
Socket
7. South Bridge
8. Audio Codec
9. Mini-Card
Connector (WLAN
Module)

Introduction

Figure 9
**Mainboard Top
Connectors**

1. USB Port
2. Hot-key board Connector
3. LCD Cable Connector
4. Keyboard Cable Connector
5. Audio Board Connector
6. Microphone Cable Connector
7. TouchPad Cable Connector
8. Fingerprint Cable Connector

Mainboard Overview - Top (Connectors)



Mainboard Overview - Bottom (Connectors)

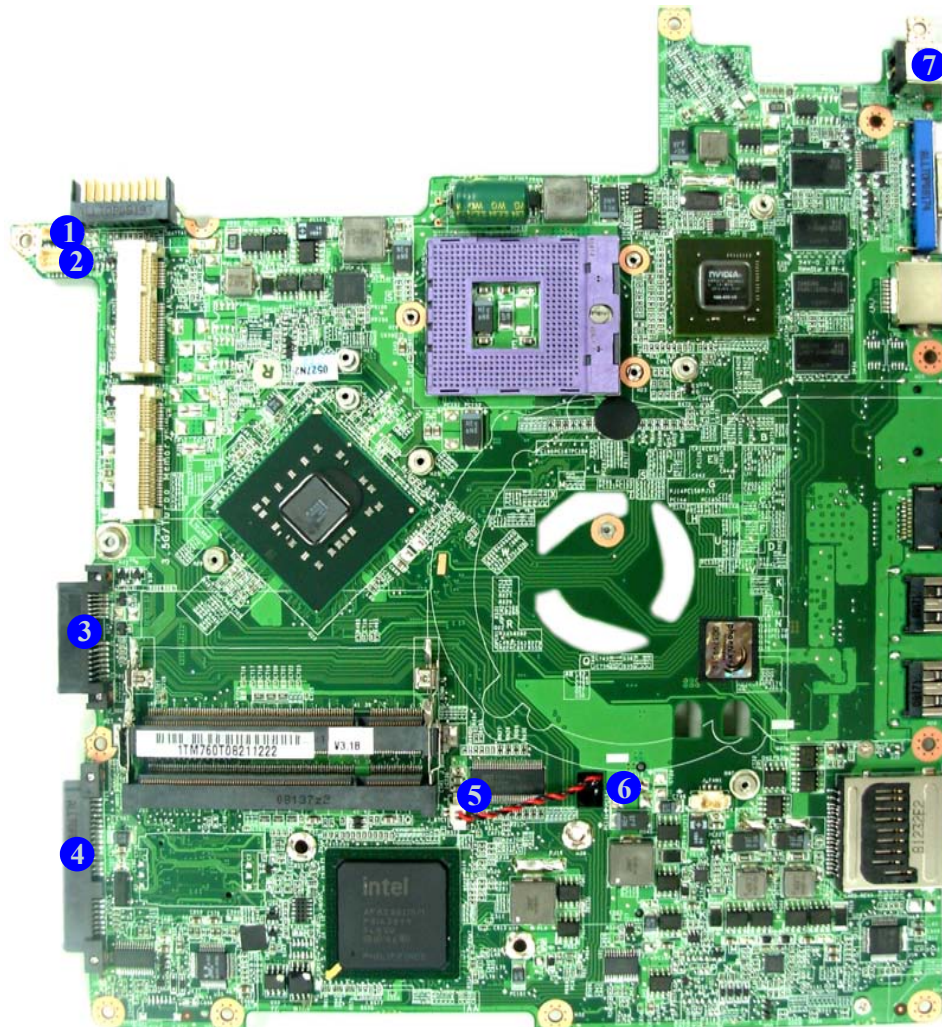

Figure 10
**Mainboard Bottom
Connectors**

1. BT Cable Connector
2. Multi Board Connector
3. CD-ROM Connector
4. HDD Connector
5. CMOS Bat. Connector
6. CPU Fan Cable Connector
7. DC-In Jack

Chapter 2: Disassembly



Overview

This chapter provides step-by-step instructions for disassembling the *M740T/M740TU/M760T/M760TU* series notebook's parts and subsystems. When it comes to reassembly, reverse the procedures (unless otherwise indicated).

We suggest you completely review any procedure before you take the computer apart.

Procedures such as upgrading/replacing the RAM, optical device and hard disk are included in the User's Manual but are repeated here for your convenience.

To make the disassembly process easier each section may have a box in the page margin. Information contained under the figure # will give a synopsis of the sequence of procedures involved in the disassembly procedure. A box with a  lists the relevant parts you will have after the disassembly process is complete. **Note:** The parts listed will be for the disassembly procedure listed ONLY, and not any previous disassembly step(s) required. Refer to the part list for the previous disassembly procedure. The amount of screws you should be left with will be listed here also.

A box with a  will also provide any possible helpful information. A box with a  contains warnings.

An example of these types of boxes are shown in the sidebar.

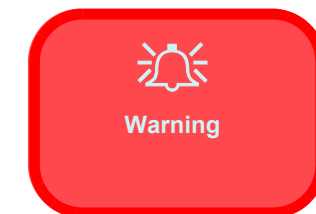
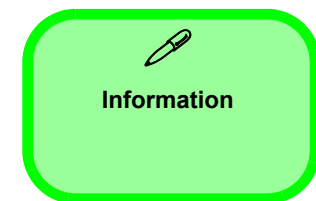

Disassembly

NOTE: All disassembly procedures assume that the system is turned **OFF**, and disconnected from any power supply (the battery is removed too).

Maintenance Tools

The following tools are recommended when working on the notebook PC:

- M3 Philips-head screwdriver
- M2.5 Philips-head screwdriver (magnetized)
- M2 Philips-head screwdriver
- Small flat-head screwdriver
- Pair of needle-nose pliers
- Anti-static wrist-strap

Connections

Connections within the computer are one of four types:

Locking collar sockets for ribbon connectors	To release these connectors, use a small flat-head screwdriver to gently pry the locking collar away from its base. When replacing the connection, make sure the connector is oriented in the same way. The pin1 side is usually not indicated.
Pressure sockets for multi-wire connectors	To release this connector type, grasp it at its head and gently rock it from side to side as you pull it out. Do not pull on the wires themselves. When replacing the connection, do not try to force it. The socket only fits one way.
Pressure sockets for ribbon connectors	To release these connectors, use a small pair of needle-nose pliers to gently lift the connector away from its socket. When replacing the connection, make sure the connector is oriented in the same way. The pin1 side is usually not indicated.
Board-to-board or multi-pin sockets	To separate the boards, gently rock them from side to side as you pull them apart. If the connection is very tight, use a small flat-head screwdriver - use just enough force to start.

Maintenance Precautions

The following precautions are a reminder. To avoid personal injury or damage to the computer while performing a removal and/or replacement job, take the following precautions:

1. **Don't drop it.** Perform your repairs and/or upgrades on a stable surface. If the computer falls, the case and other components could be damaged.
2. **Don't overheat it.** Note the proximity of any heating elements. Keep the computer out of direct sunlight.
3. **Avoid interference.** Note the proximity of any high capacity transformers, electric motors, and other strong magnetic fields. These can hinder proper performance and damage components and/or data. You should also monitor the position of magnetized tools (i.e. screwdrivers).
4. **Keep it dry.** This is an electrical appliance. If water or any other liquid gets into it, the computer could be badly damaged.
5. **Be careful with power.** Avoid accidental shocks, discharges or explosions.
 - Before removing or servicing any part from the computer, turn the computer off and detach any power supplies.
 - When you want to unplug the power cord or any cable/wire, be sure to disconnect it by the plug head. Do not pull on the wire.
6. **Peripherals** – Turn off and detach any peripherals.
7. **Beware of static discharge.** ICs, such as the CPU and main support chips, are vulnerable to static electricity. Before handling any part in the computer, discharge any static electricity inside the computer. When handling a printed circuit board, do not use gloves or other materials which allow static electricity buildup. We suggest that you use an anti-static wrist strap instead.
8. **Beware of corrosion.** As you perform your job, avoid touching any connector leads. Even the cleanest hands produce oils which can attract corrosive elements.
9. **Keep your work environment clean.** Tobacco smoke, dust or other air-borne particulate matter is often attracted to charged surfaces, reducing performance.
10. **Keep track of the components.** When removing or replacing any part, be careful not to leave small parts, such as screws, loose inside the computer.

Cleaning

Do not apply cleaner directly to the computer, use a soft clean cloth.

Do not use volatile (petroleum distillates) or abrasive cleaners on any part of the computer.



Power Safety Warning

Before you undertake any upgrade procedures, make sure that you have turned off the power, and disconnected all peripherals and cables (including telephone lines). It is advisable to also remove your battery in order to prevent accidentally turning the machine on.

Disassembly Steps

The following table lists the disassembly steps, and on which page to find the related information. **PLEASE PERFORM THE DISASSEMBLY STEPS IN THE ORDER INDICATED.**

To remove the Battery:

1. Remove the battery [page 2 - 5](#)

To remove the HDD:

1. Remove the battery [page 2 - 5](#)
2. Remove the HDD [page 2 - 6](#)

To remove the Optical Device:

1. Remove the battery [page 2 - 5](#)
2. Remove the Optical device [page 2 - 9](#)

To remove the System Memory:

1. Remove the battery [page 2 - 5](#)
2. Remove the system memory [page 2 - 11](#)

To remove the Inverter Board:

1. Remove the battery [page 2 - 5](#)
2. Remove the inverter board [page 2 - 13](#)

To remove and install a Processor:

1. Remove the battery [page 2 - 5](#)
2. Remove the processor [page 2 - 14](#)
3. Install the processor [page 2 - 16](#)

To remove the Wireless LAN Module:

1. Remove the battery [page 2 - 5](#)
2. Remove the wireless LAN [page 2 - 17](#)

To remove the Bluetooth Module:

1. Remove the battery [page 2 - 5](#)
2. Remove the Bluetooth [page 2 - 18](#)

To remove the Keyboard:

1. Remove the battery [page 2 - 5](#)
2. Remove the keyboard [page 2 - 19](#)

To remove the Modem:

1. Remove the battery [page 2 - 5](#)
2. Remove the HDD [page 2 - 6](#)
3. Remove the system memory [page 2 - 11](#)
4. Remove the Optical device [page 2 - 9](#)
5. Remove the processor [page 2 - 14](#)
6. Remove the keyboard [page 2 - 19](#)
7. Remove the modem [page 2 - 20](#)

Removing the Battery

1. Turn the computer **off**, and turn it over.
2. Slide the latch **1** in the direction of the arrow.
3. Slide the latch **2** in the direction of the arrow, and hold it in place.
4. Slide the battery **3** in the direction of the arrow **4**.

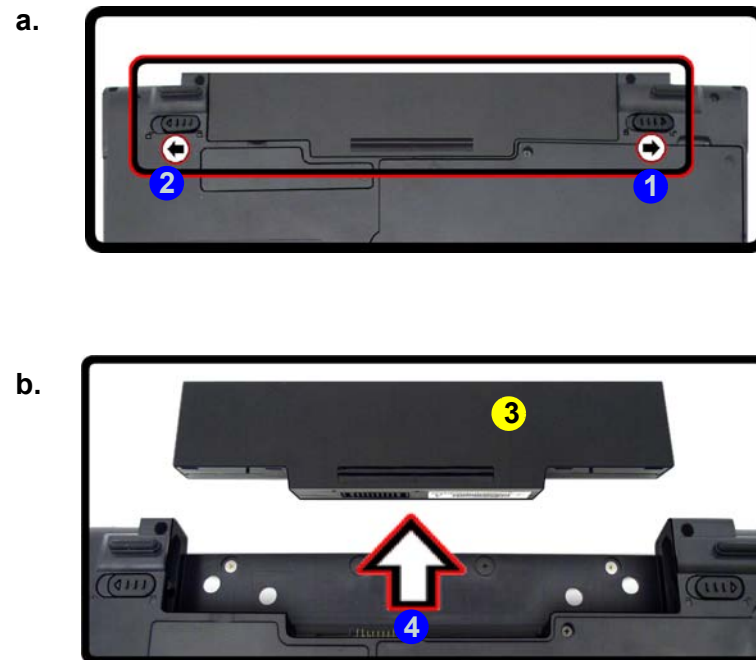
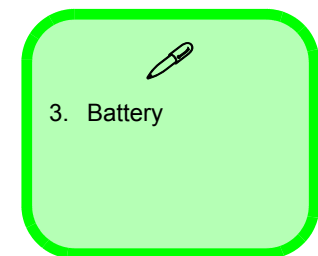

Figure 1
Battery Removal

- a. Slide the latch and hold in place.
- b. Slide the battery in the direction of the arrow.



Removing the Hard Disk Drive

Figure 2
**HDD Assembly
Removal**

The hard disk drive can be taken out to accommodate other 2.5" serial (SATA) hard disk drives with a height of 9.5mm (h). Follow your operating system's installation instructions, and install all necessary drivers and utilities (as outlined in **Chapter 4 of the User's Manual**) when setting up a new hard disk.

- a. Locate the HDD bay cover and remove the screw(s).

Hard Disk Upgrade Process

1. Turn **off** the computer, and remove the battery ([page 2 - 5](#)).
2. Locate the hard disk bay cover and remove screw **1** & **2**.



- 2 Screws



HDD System Warning

New HDD's are blank. Before you begin make sure:

You have backed up any data you want to keep from your old HDD.

You have all the CD-ROMs and FDDs required to install your operating system and programs.

If you have access to the internet, download the latest application and hardware driver updates for the operating system you plan to install. Copy these to a removable medium.

For M740T/M740TU computers:

3. Remove the hard disk bay cover **3**.
4. Grip the tab and slide the hard disk in the direction of arrow **4**.
5. Lift the hard disk out of the bay **5**.
6. Remove the screw **6** and the adhesive cover **7** from the hard disk **8**.
7. Reverse the process to install a new hard disk (do not forget to replace all the screws and covers).

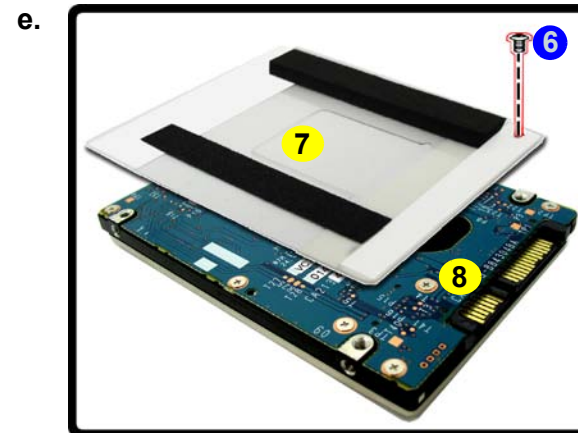
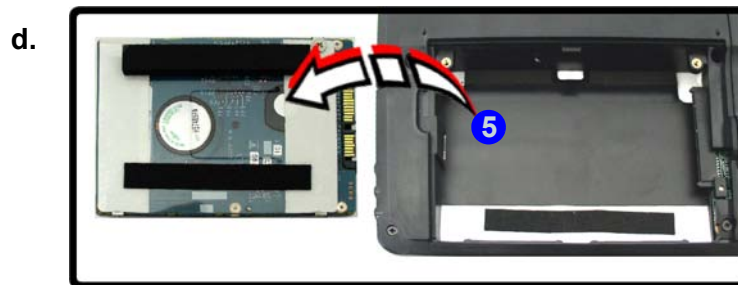

Figure 3
**HDD Assembly
Removal (cont'd.)**

- b. Remove the HDD bay cover.
- c. Grip the tab and slide the HDD in the direction of the arrow.
- d. Lift the HDD assembly out of the bay.
- e. Remove the screw and adhesive cover.



Disassembly

Figure 4
HDD Assembly
Removal (cont'd.)

- f. Remove the HDD Bay Cover.
- g. Grip the tab and slide the HDD in the direction of the arrow.
- h. Lift the HDD assembly out of the bay.
- i. Remove the screw and adhesive cover.

For **M760T/M760TU** computers:

8. Remove the hard disk bay Cover **3**.
9. Grip the tab and slide the hard disk in the direction of arrow **4**.
10. Lift the hard disk out of the bay **5**.
11. Remove the screws **6** & **7** and the adhesive cover **8** from the hard disk **9**.
12. Reverse the process to install a new hard disk (do not forget to replace all the screws and covers).

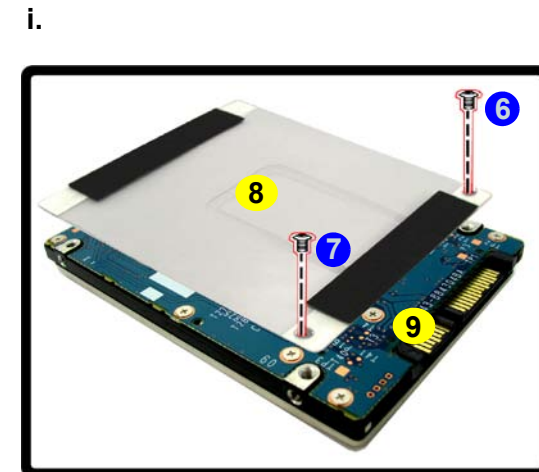
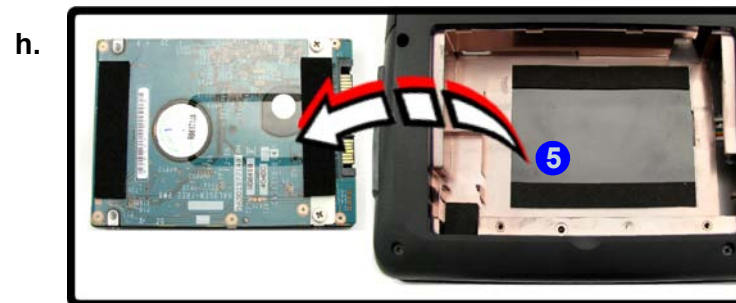
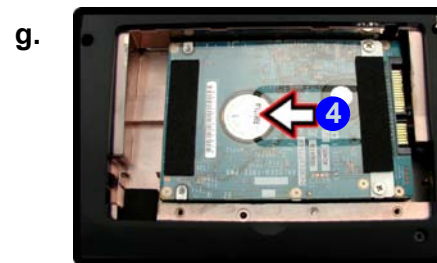
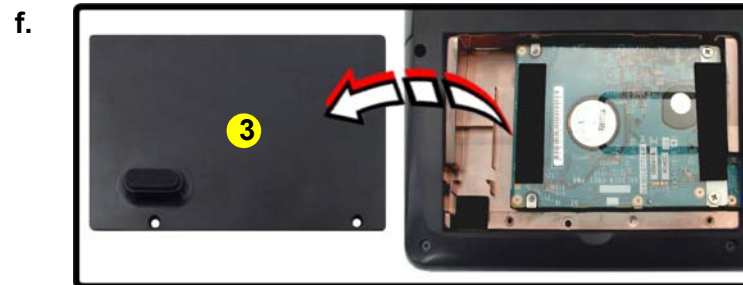

- 3. HDD Bay Cover
- 8. Adhesive Cover
- 9. HDD

- 2 Screws

Removing the Optical (CD/DVD) Device

1. Turn **off** the computer, and remove the battery ([page 2 - 5](#)).
2. **M740T/M740TU: (see over for M760T/M760TU)** Locate the component bay cover **1** and remove screws **2** - **4**.
3. Carefully (**a fan and cable are attached to the under side of the cover**) lift up the bay cover.
4. Carefully disconnect the fan cable **5**, and remove the cover **1**.
5. Remove the screw at point **6**, and use a screwdriver to carefully push out the optical device **8** at point **7**.
6. Insert the new device and carefully slide it into the computer (the device only fits one way. **DO NOT FORCE IT**; The screw holes should line up).
7. Restart the computer to allow it to automatically detect the new device.

Figure 5
Optical Device Removal

- a. Remove the screws.
- b. Disconnect the fan cable and remove the cover.
- c. Remove the screw.
- d. Push the optical device out off the computer at point 7.

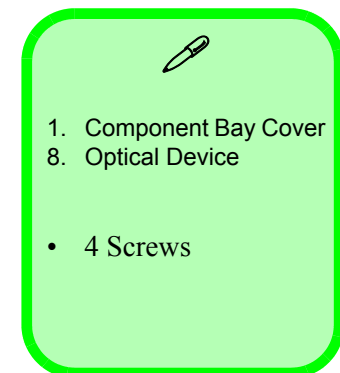
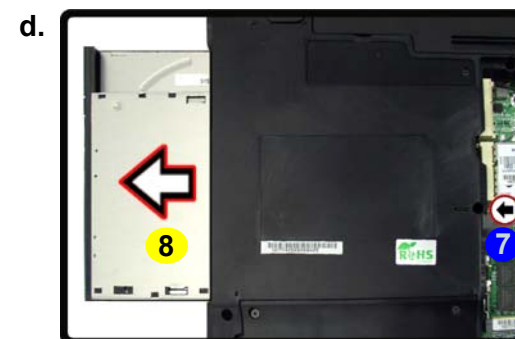
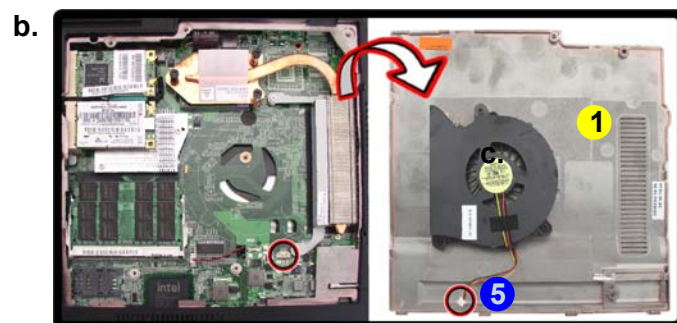
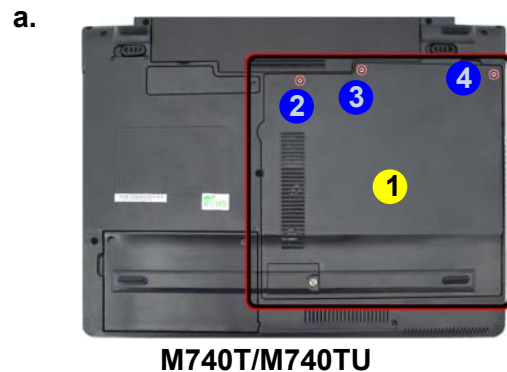

Disassembly

Figure 6
Optical Device
Removal (cont'd.)

- e. Remove the screws.
- f. Remove the cover.
- g. Remove the screw.
- h. Push the optical device out off the computer at point 7.

- 8. **M760T/M760TU:** Locate the hard disk bay cover **1** and loosen screws **2** & **3**.
- 9. Remove the hard disk bay cover **1**.
- 10. Remove the screw at point **6**, and use a screwdriver to carefully push out the optical device **8** at point **7**.
- 11. Insert the new device and carefully slide it into the computer (the device only fits one way. DO NOT FORCE IT; The screw holes should line up).
- 12. Restart the computer to allow it to automatically detect the new device.

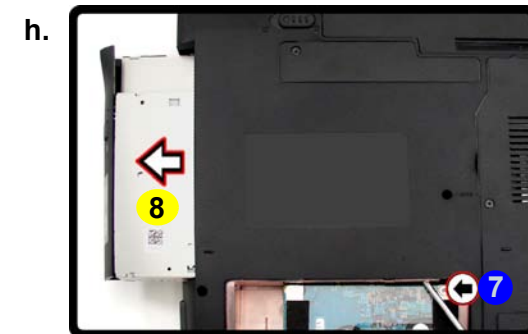
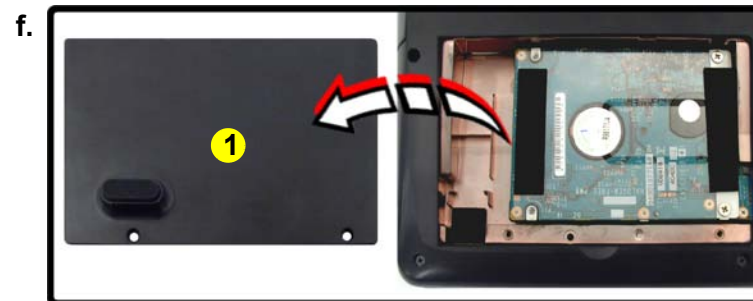
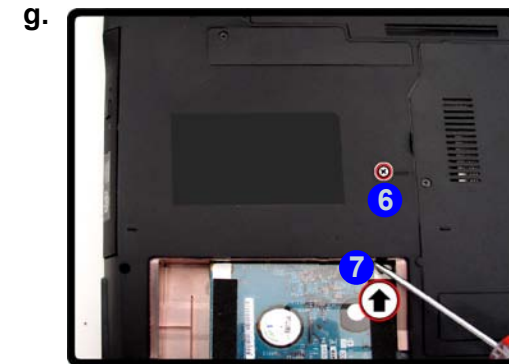

- 1. HDD Bay Cover
- 8. Optical Device

- 4 Screws

Removing the System Memory (RAM)

The computer has two memory sockets for 200 pin Small Outline Dual In-line Memory Modules (SO-DIMM) supporting **DDR2** 667/800MHz. The main memory can be expanded up to 4GB. The SO-DIMM modules supported are 1024MB, and 2048MB and **DDRII** Modules. The total memory size is automatically detected by the POST routine once you turn on your computer.

Memory Upgrade Process

1. Turn **off** the computer, remove the battery ([page 2 - 5](#)).
2. Locate the component bay cover **1**, and remove screws **2** - **4**.
3. Carefully (**a fan and cable are attached to the under side of the cover**) lift up the bay cover.
4. Carefully disconnect the fan cable **5**, and remove the cover **1**.

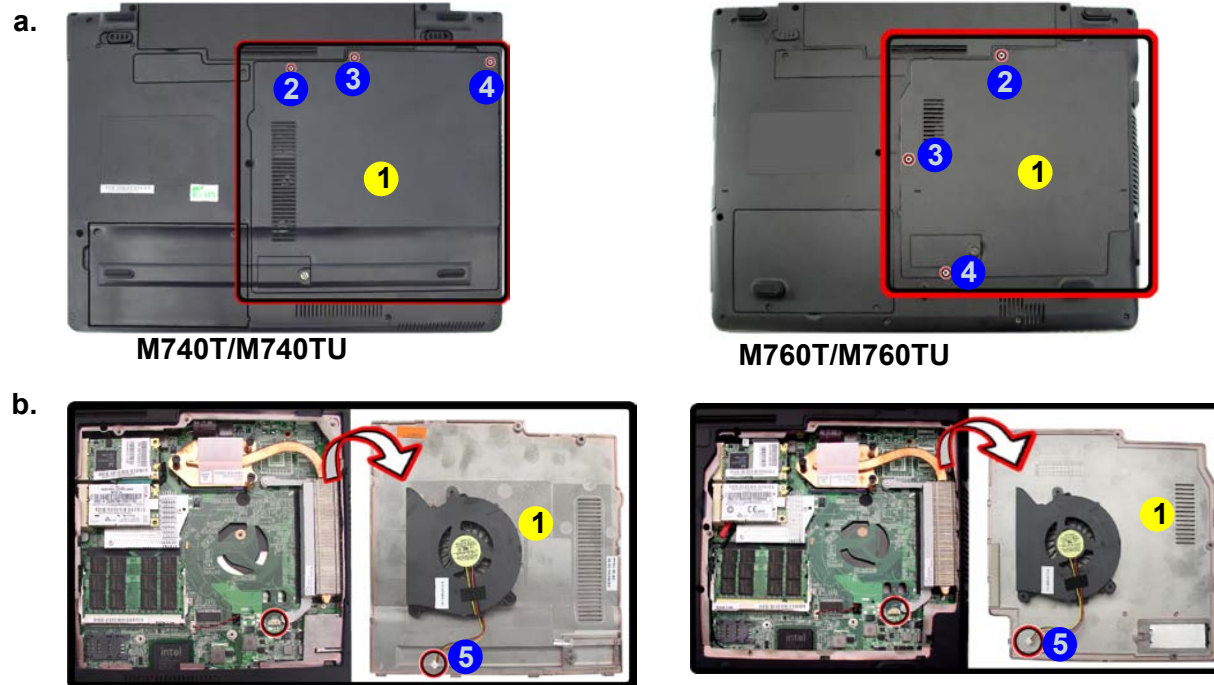

Figure 7
RAM Module Removal

- a. Remove the screws.
- b. Remove the cover.



Contact Warning

Be careful not to touch the metal pins on the module's connecting edge. Even the cleanest hands have oils which can attract particles, and degrade the module's performance.



1. Component Bay Cover
- 3 Screws

Disassembly

Figure 8 RAM Module Removal (cont'd.)

- c. Pull the release latch(es).
d. Remove the module(s).
e. Properly re-insert the bay cover pins.

5. Gently pull the two release latches (6 & 7) on the sides of the memory socket in the direction indicated by the arrows (Figure 8c).

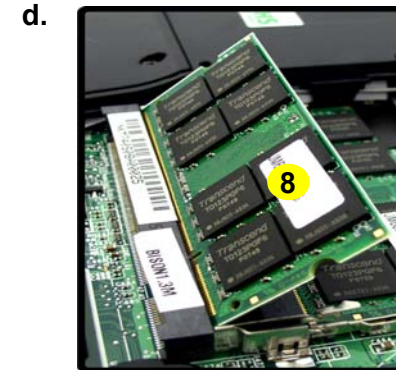
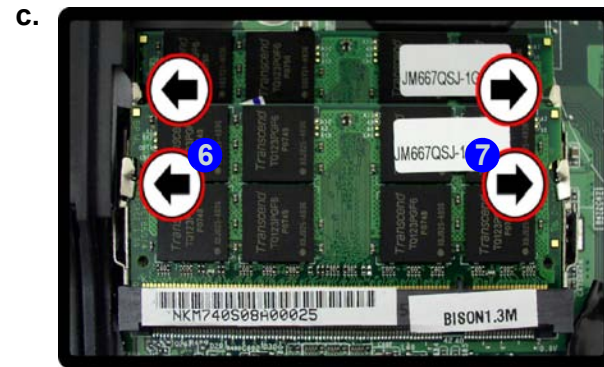

6. The RAM module(s) 8 will pop-up (Figure 8d), and you can then remove it.
7. Pull the latches to release the second module if necessary.
8. Insert a new module holding it at about a 30° angle and fit the connectors firmly into the memory slot.
9. The module's pin alignment will allow it to only fit one way. Make sure the module is seated as far into the slot as it will go. DO NOT FORCE the module; it should fit without much pressure.
10. Press the module in and down towards the mainboard until the slot levers click into place to secure the module.
11. Replace the bay cover and screws (make sure you reconnect the fan cable before screwing down the bay cover).

Note for M760T/M760TU computers that there are four 9 - 12 cover pins which need to be aligned with slots in the case, to insure a proper cover fit, before screwing down the bay cover 1.

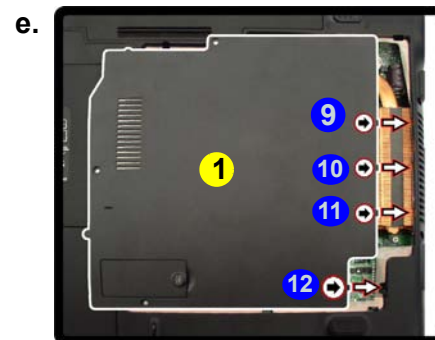

12. Restart the computer to allow the BIOS to register the new memory configuration as it starts up.



8. RAM Module(s)

2 - 12 Removing the System Memory (RAM)

Removing the Inverter Board

1. Turn **off** the computer, and remove the battery ([page 2 - 5](#)).
2. Remove any rubber covers, screws **1** - **6** ([Figure 9a](#)), then run your finger around the middle of the frame to carefully unsnap the LCD front panel module **7** from the back.
3. Discharge the remaining system power (see [“Inverter Power Warning”](#) below).
4. Remove screw **8** ([Figure 9b](#)) from the inverter, and carefully lift the inverter board up slightly.
5. Disconnect cables **9** & **10** ([Figure 9c](#)) from the inverter, then remove the inverter **11** ([Figure 9d](#)) from the top case assembly.

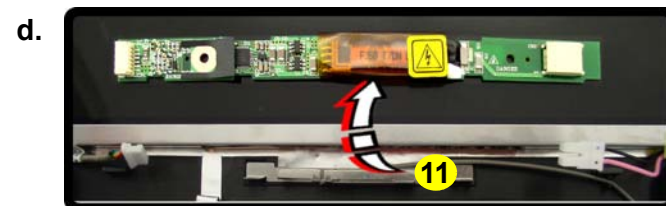
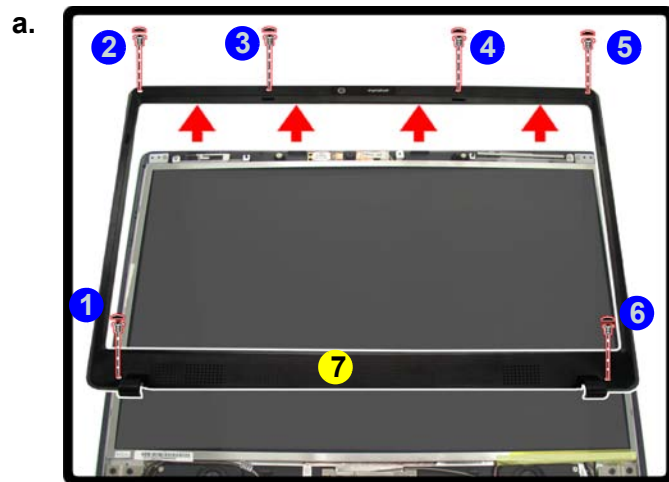



Figure 9
Inverter Board Removal

- a. Remove the 6 screws and unsnap the LCD front panel module from the back.
- b. Remove the screw and discharge the remaining power from the inverter board and lift the board up slightly.
- c. Disconnect the cables from the inverter.
- d. Remove the inverter.

Inverter Power Warning

In order to prevent a short circuit when removing the inverter it is necessary to discharge any remaining system power. To do so, press the computer's power button for a few seconds before disconnecting the inverter cable.



7. LCD Front Panel
11. Inverter Board

- 6 Screws

Removing and Installing the Processor

Processor Removal Procedure

Figure 10

Processor Removal

- Remove the cover and locate the heat sink.
- Remove the screws in the order indicated.
- Remove the heat sink.

- Turn off the computer, remove the battery (page 2 - 5) and the component bay cover (page 2 - 11).
- The CPU heat sink will be visible at point 1 on the mainboard.
- Remove screws 2 - 4 (Figure 10b) from the heat sink in the order indicated.
- Carefully lift up the heat sink 5 (Figure 10c) off the computer.

a.

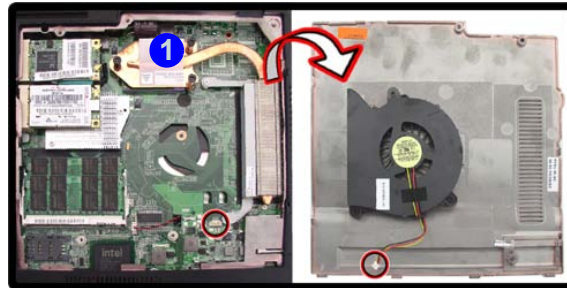

M740T/M740TU

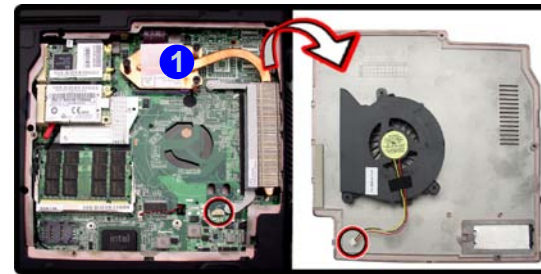

M760T/M760TU

b.

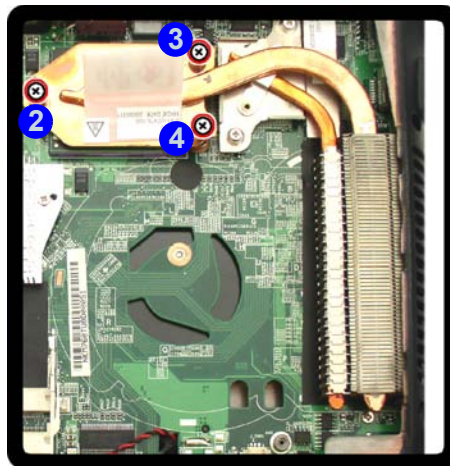

c.

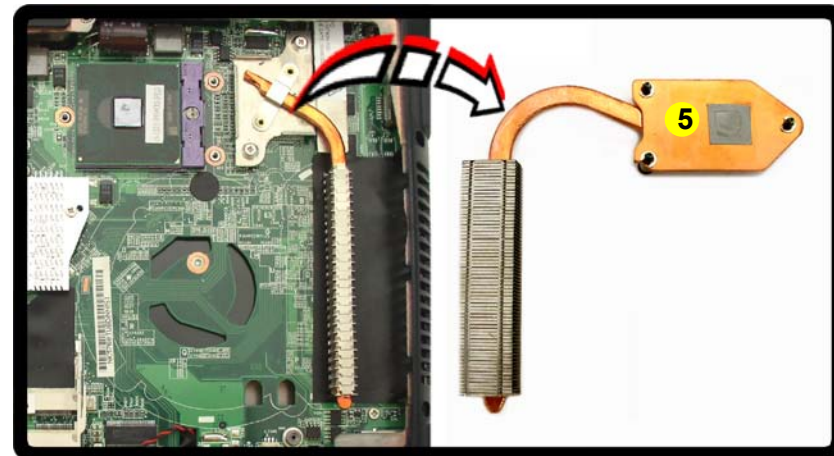

5. Heat Sink

- 3 Screws

- Turn the release latch **6** towards the unlock symbol , to release the CPU (*Figure 11a*).
- Carefully (it may be hot) lift the CPU **7** up out of the socket (*Figure 11b*).
- See [page 2 - 16](#) for information on inserting a new CPU.
- When re-inserting the CPU, pay careful attention to the pin alignment, it will fit only one way (DO NOT FORCE IT!).

Figure 11
Processor Removal
(cont'd)

- Turn the release latch to unlock the CPU.
- Lift the CPU out of the socket.

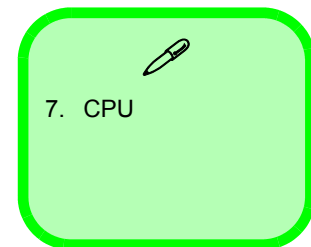
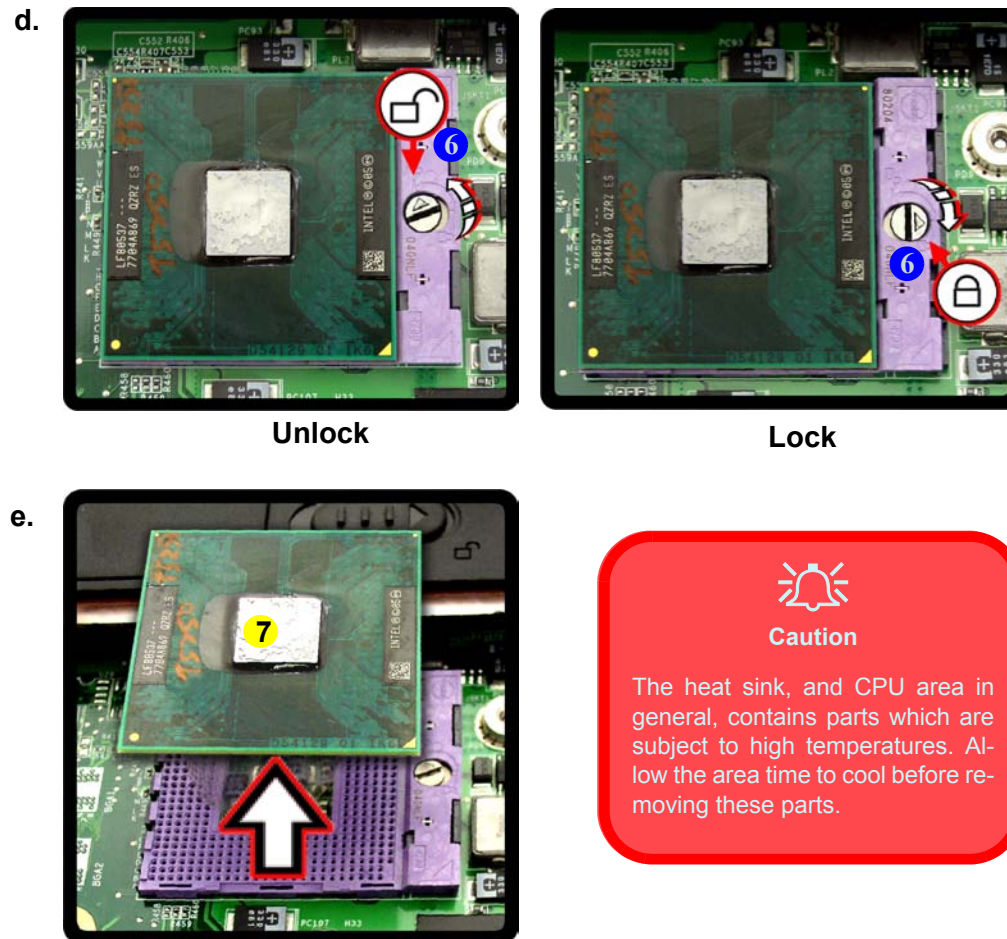

Disassembly

Figure 12
Processor Installation

- Insert the CPU.
- Turn the release latch towards the lock symbol.
- Remove the sticker from the heat sink and insert the heat sink.
- Tighten the screws.

Processor Installation Procedure

- Insert the CPU **1**, pay careful attention to the pin alignment, it will fit only one way (DO NOT FORCE IT!), and turn the release latch **2** towards the lock symbol  (*Figure 12b*).
- Remove the sticker **3**** (*Figure 12c*) from the heat sink.
- Insert the heat sink **4** as indicated in *Figure 12c*.
- Tighten screws **5** - **7** in the order indicated on the label.
- Replace the component bay cover and tighten the screws (*page 2 - 14*).

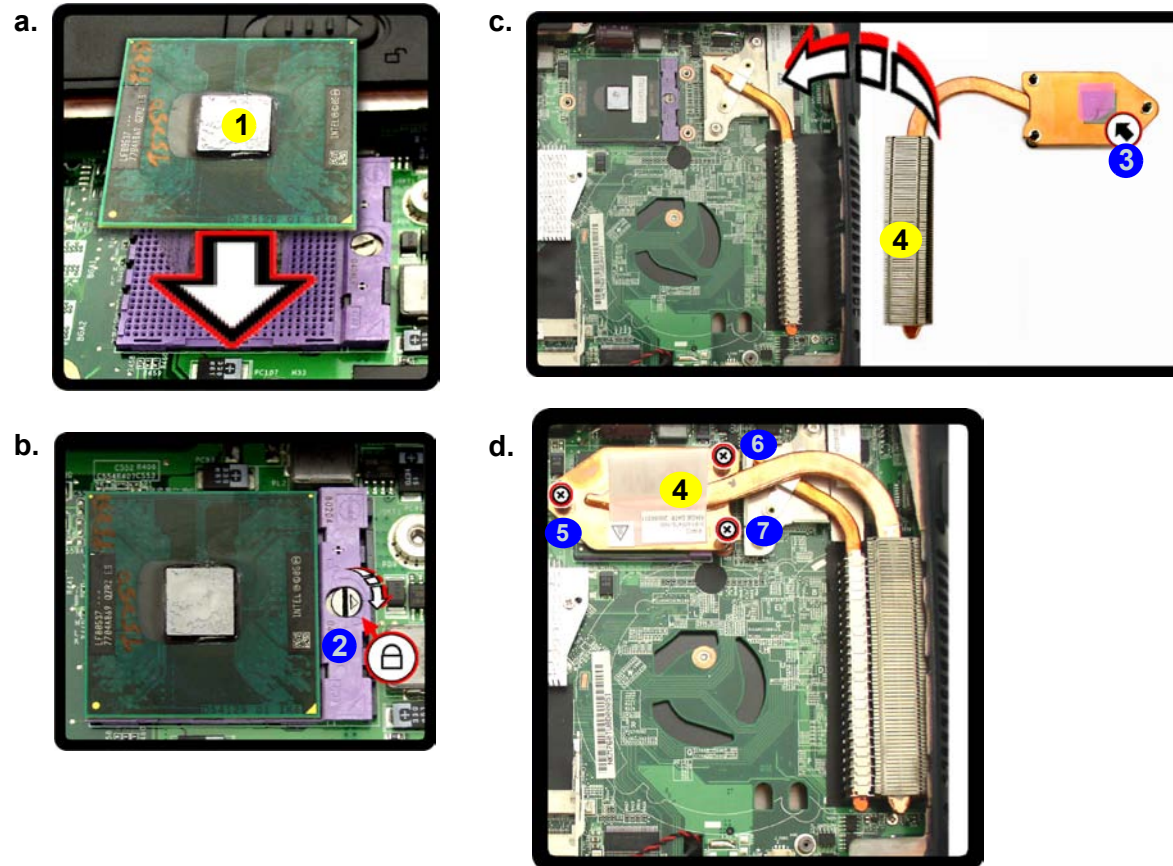

- 
- CPU
 - Heat Sink
- 3 Screws

Removing the Wireless LAN Module

1. Turn **off** the computer, remove the battery ([page 2 - 5](#)) and the component bay cover ([page 2 - 11](#)).
2. The Wireless LAN module will be visible at point **1** on the mainboard.
3. Carefully disconnect cables **2** - **3**, then remove screw **4** from the module socket.
4. The Wireless LAN module **5** will pop-up.
5. Lift the Wireless LAN module ([Figure 13d](#)) up and off the computer.

a. M740T/M740TU

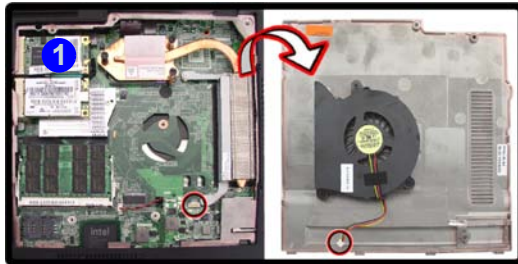

M760T/M760TU

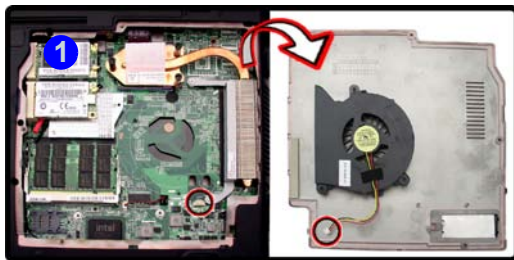

b.



c.



d.

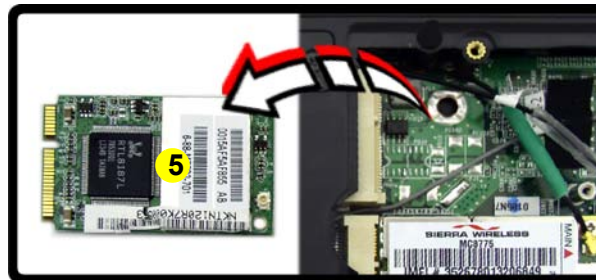
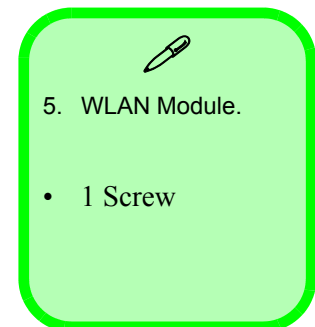

Figure 13
**Wireless LAN
Module Removal**

- a. Remove the cover.
- b. Disconnect the cable and remove the screw.
- c. The WLAN module will pop up.
- d. Lift the WLAN module out.

Note: Make sure you reconnect the antenna cable to “1” + “2” socket ([Figure b](#)).



Disassembly

Figure 14
**Bluetooth Module
 Removal**

- Remove the screw.
- Lfit the cover and remove the screw.
- Disconnect the cable and the connector.
- Lift the Bluetooth module up off the socket.

Removing the Bluetooth Module

- Turn **off** the computer, remove the battery ([page 2 - 5](#)).
- Locate the Bluetooth bay cover, and remove the screw **1** and cover **2**.
- Remove the screw **3** and turn the module over.
- Carefully separate the Bluetooth module from the connector **4** and disconnect the cable **5**.
- Lift the Bluetooth module **6** ([Figure 14c](#)) up and off the computer.

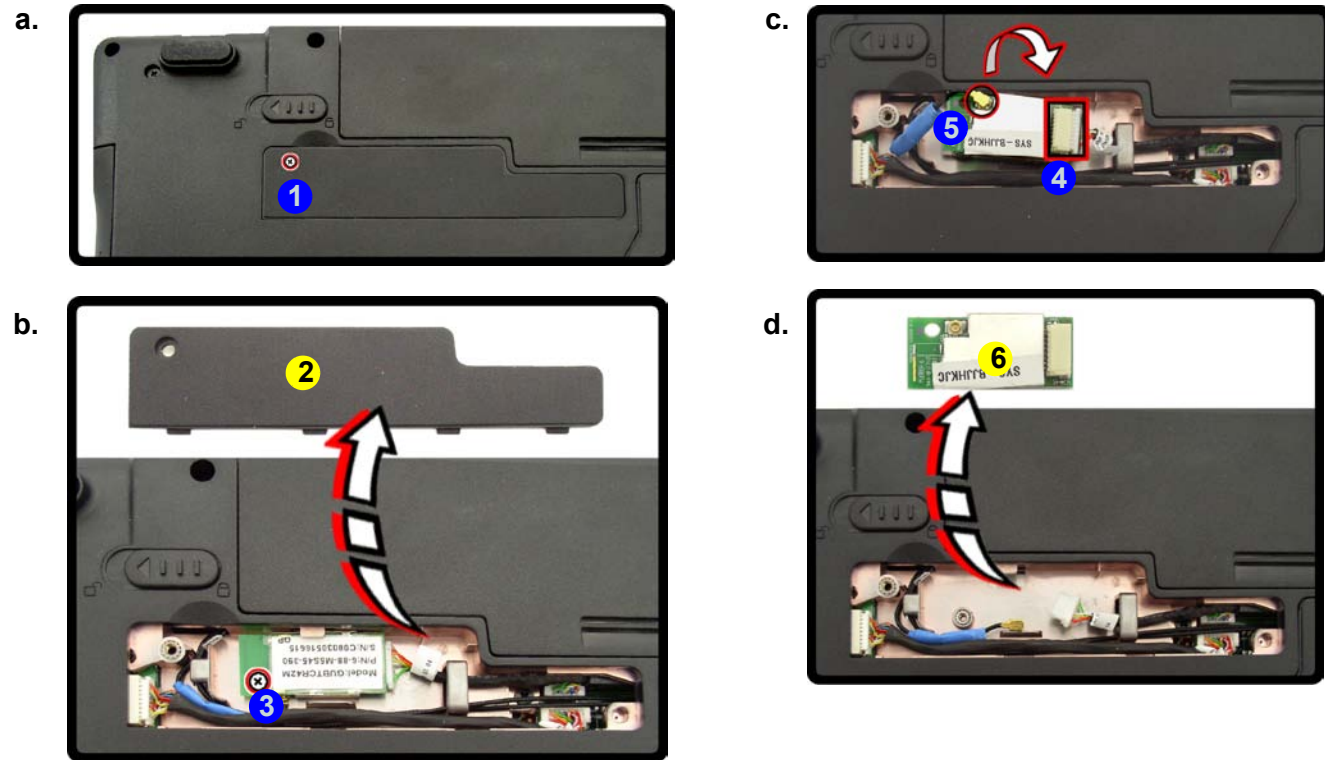

- 2. Cover
- 6. Bluetooth Module

- 2 Screws

Removing the Keyboard

1. Turn **off** the computer, and remove the battery ([page 2 - 5](#)).
2. Press the **four** keyboard latches at the top of the keyboard to elevate the keyboard from its normal position (you may need to use a small screwdriver to do this).
3. Carefully lift the keyboard **5** up, being careful not to bend the keyboard ribbon cable ([Figure 15b](#)).
4. Disconnect the keyboard ribbon cable **6** from the locking collar socket **7**.

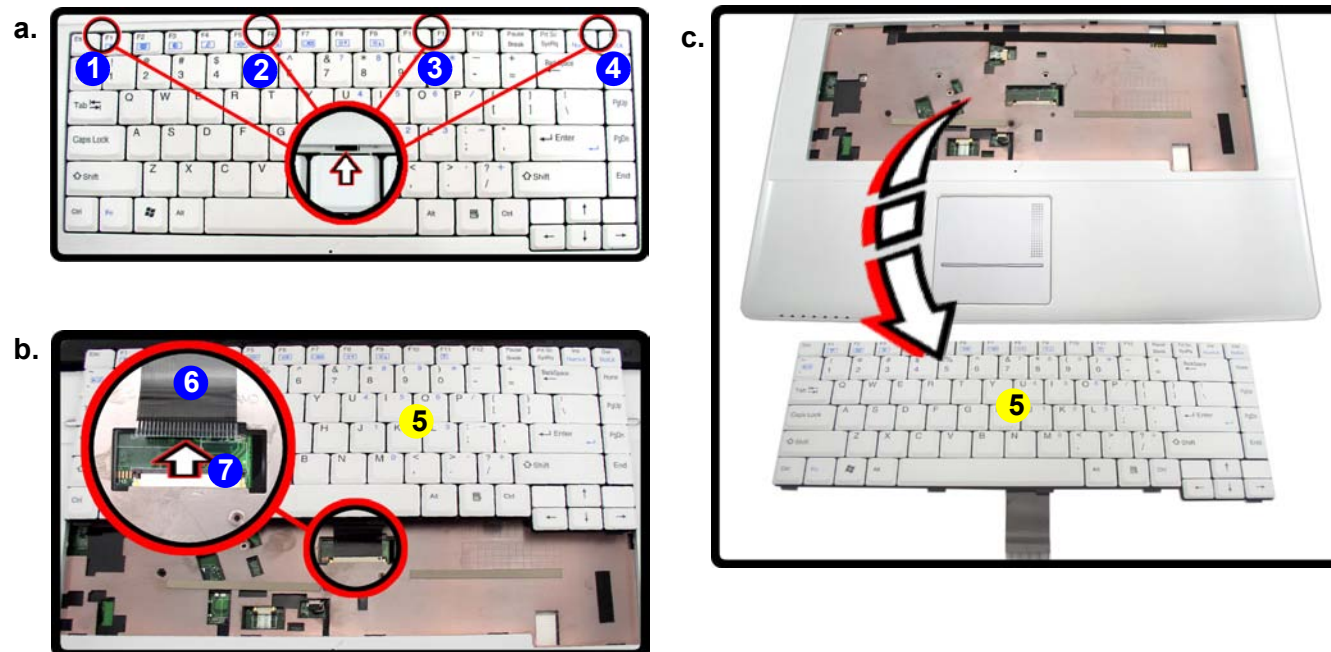

Figure 15
Keyboard Removal

- a. Press the four latches to release the keyboard.
- b. Lift the keyboard up and disconnect the cable from the locking collar.
- c. Remove the keyboard.



Re-Inserting the Keyboard

When re-inserting the keyboard firstly align the **four** keyboard tabs at the bottom of the keyboard with the slots in the case.



5. Keyboard

Disassembly

Figure 16

Modem Removal

- Remove the screws and disconnect the cable.
- Turn the computer over, remove the screws and disconnect the cable.
- Remove the screws.

Removing the Modem

- Turn **off** the computer, remove the battery ([page 2 - 5](#)), HDD ([page 2 - 6](#)), component bay cover ([page 2 - 11](#)), optical device ([page 2 - 9](#)), CPU ([page 2 - 14](#)), bluetooth ([page 2 - 18](#)) and keyboard ([page 2 - 19](#)).
- Remove screws **1** - **18** from the bottom case and carefully disconnect the cable **19** from the mainboard ([Figure 17a](#)).
- Turn the computer over, remove screws **20** - **21** and disconnect cables **22** - **24** ([Figure 17b](#)).
- For M760T/M760TU only** - remove screws **25** - **26** ([Figure 17c](#)) from the rear of the computer.

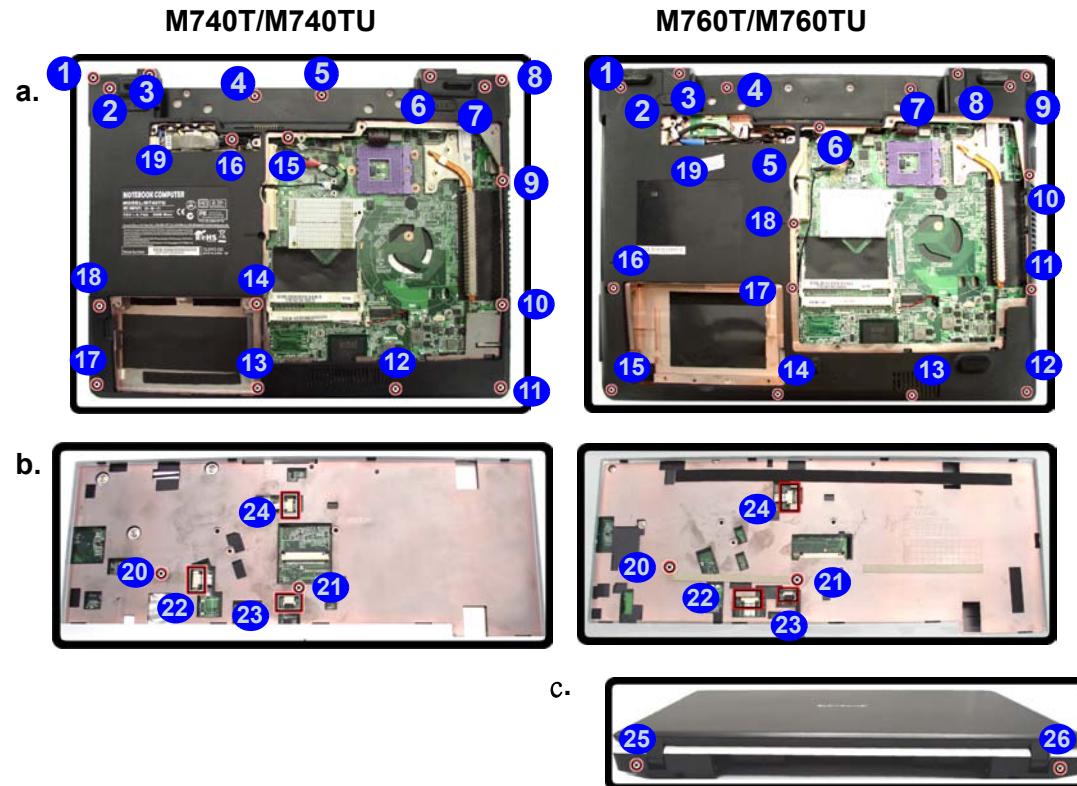

- 20 Screws (M740T/ M740TU)/ 22 Screws (M760T/ M760TU)

5. Carefully lift the top case **27** up and off the computer (*Figure 17d*).
6. Remove screws **28** - **30** (*Figure 17e*) from the computer.
7. Remove screws **31** - **32** (*Figure 17f*) from the modem module.
8. Lift the modem up and separate the modem from the connector **33**.
9. Lift the modem **34** off the computer.

Figure 17
Modem Removal
(cont'd.)

- d. Lift the cover off the computer.
- e. Remove the screws.
- f. Remove the screws and disconnect the connector.
- g. Lift the modem out.

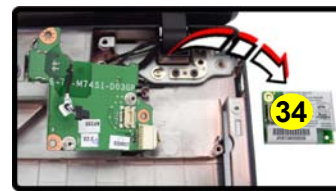
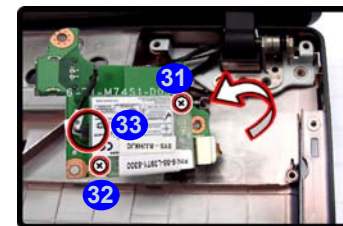
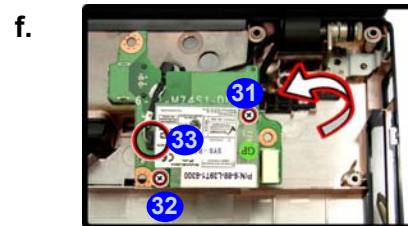
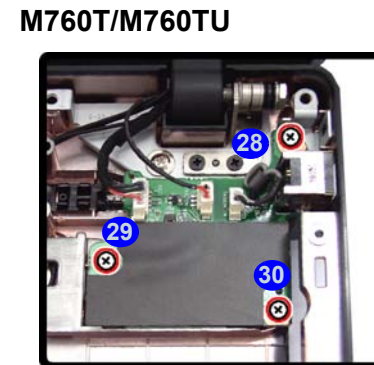
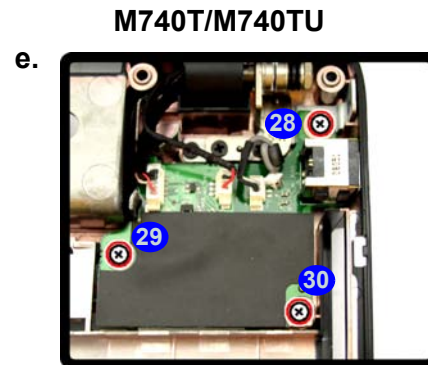
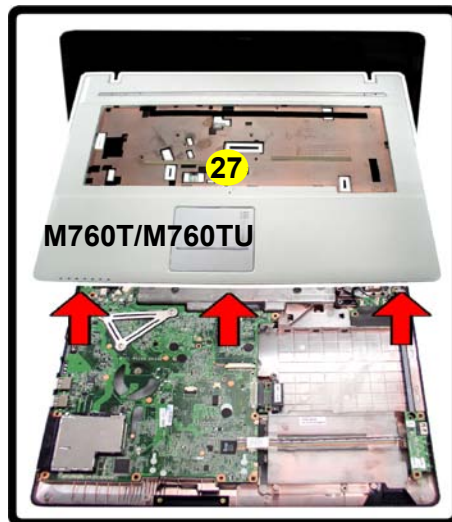
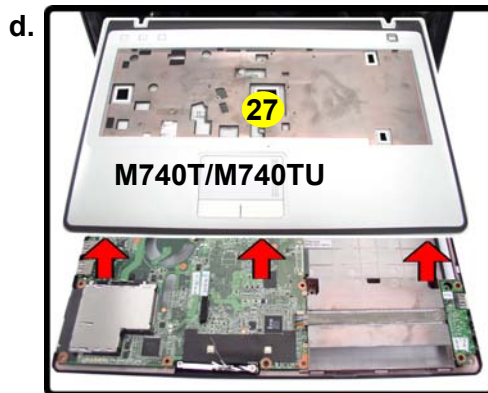

27. Top Case
34. Modem

- 5 Screws (M740T/M740TU/M760T/M760TU)

Appendix A: Part Lists

This appendix breaks down the *M740T/M740TU/M760T/M760TU* series notebook's construction into a series of illustrations. The component part numbers are indicated in the tables opposite the drawings.

Note: This section indicates the *manufacturer's* part numbers. Your organization may use a different system, so be sure to cross-check any relevant documentation.

Note: Some assemblies may have parts in common (especially screws). However, the part lists DO NOT indicate the total number of duplicated parts used.

Note: Be sure to check any update notices. The parts shown in these illustrations are appropriate for the system at the time of publication. Over the product life, some parts may be improved or re-configured, resulting in *new* part numbers.

Part List Illustration Location

The following table indicates where to find the appropriate part list illustration.

Table A- 1
**Part List Illustration
Location**

Parts	M740T	M740TU	M760T	M760TU
Top with Fingerprint	<i>page A - 3</i>		<i>page A - 11</i>	
Top without Fingerprint	<i>page A - 4</i>		<i>page A - 12</i>	
Bottom	<i>page A - 5</i>	<i>page A - 6</i>	<i>page A - 13</i>	<i>page A - 14</i>
LCD	<i>page A - 7</i>		<i>page A - 15</i>	
HDD	<i>page A - 8</i>		<i>page A - 16</i>	
COMBO	<i>page A - 9</i>		<i>page A - 17</i>	
DVD-Dual Drive	<i>page A - 10</i>		<i>page A - 18</i>	

Top with Fingerprint (M740T/M740TU)

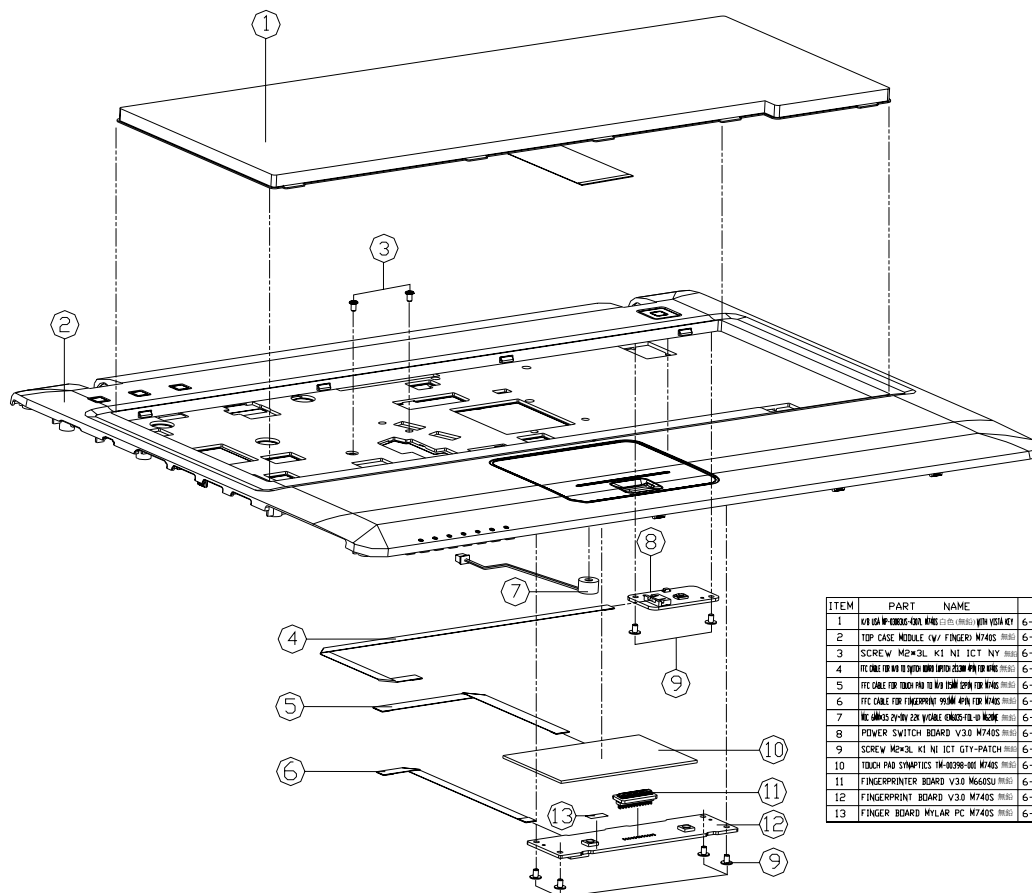

Figure A - 1
Top with
Fingerprint
(M740T/M740TU)

ITEM	PART NAME	PART NO	REMARK
1	TOP CASE MODULE (w/ FINGER) M740S	6-80-M740S-011-1	
2	TOP CASE MODULE (w/ FINGER) M740S	6-39-M740S-114	
3	SCREW M2x3L K1 NI ICT NY	6-35-B1120-3RA	
4	ITC CABLE FOR TOUCH PAD TO MAIN BOARD (PCB) FOR M740S	6-43-M740S-030	
5	ITC CABLE FOR TOUCH PAD TO MAIN BOARD (PCB) FOR M740S	6-43-M740S-040	
6	ITC CABLE FOR FINGERPRINT SENSOR (PCB) FOR M740S	6-43-M740SF-010	
7	MC (M6625 2x4V 28V) BOARD (PCB) FOR M740S	6-23-EM62E-010	
8	POWER SWITCH BOARD V3.0 M740S	6-77-M740SS-003	
9	SCREW M2x3L K1 NI ICT GTY-PATCH	6-35-B1120-3RE	
10	TOUCH PAD SYNAPTICS TM-00298-000 M740S	6-49-M740S2-010	
11	FINGERPRINTER BOARD V3.0 M660SU	6-77-M66UF-003	
12	FINGERPRINT BOARD V3.0 M740S	6-77-M740SF-003	
13	FINGER BOARD MYLAR PC M740S	6-40-M740SS-070	

A.Part Lists

Top without Fingerprint (M740T/M740TU)

Figure A - 2
Top without Fingerprint
(M740T/M740TU)

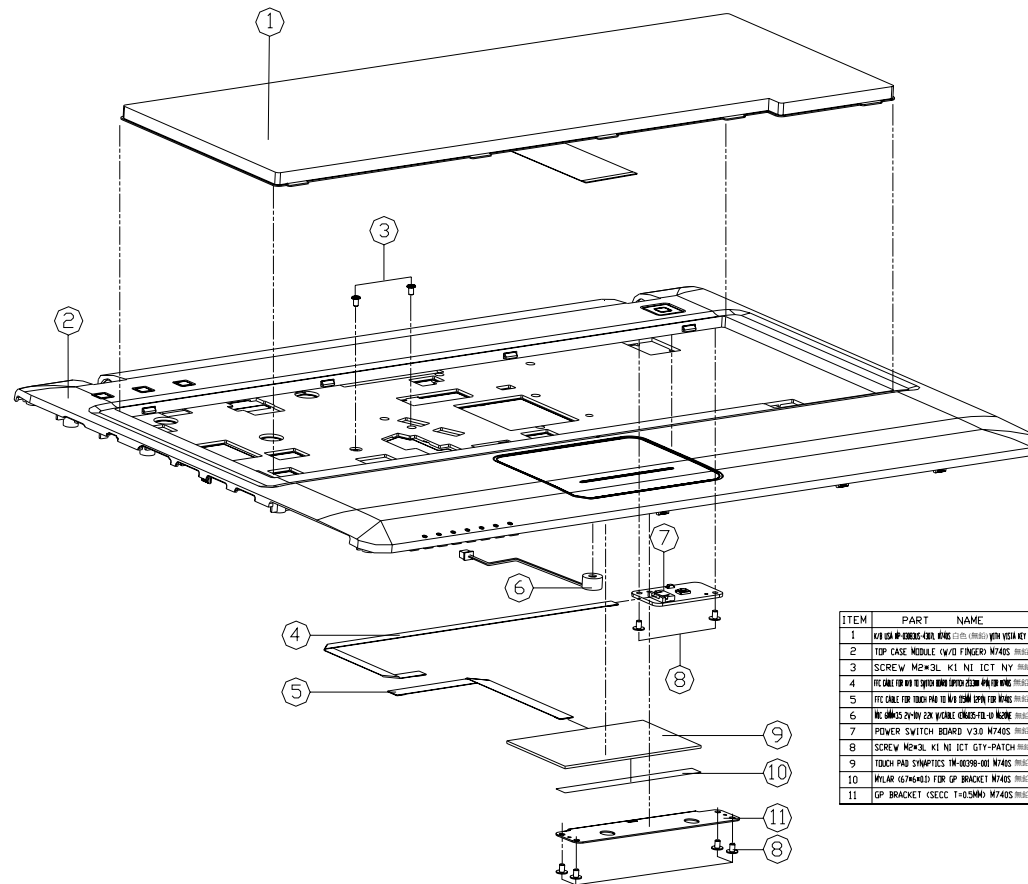

ITEM	PART NAME	PART NO	REMARK
1	TOP CASE MODULE (w/O FINGER) M740S	6-80-M74S0-011-1	
2	TOP CASE MODULE (w/O FINGER) M740S	6-39-M74S2-014	
3	SCREW M2*3L KI NI ICT NY	6-35-B1120-3RA	
4	TOP CASE MODULE (w/O FINGER) M740S	6-43-M74S0-030	
5	TOP CASE MODULE (w/O FINGER) M740S	6-43-M74S0-040	
6	TOP CASE MODULE (w/O FINGER) M740S	6-23-EM62E-010	
7	POWER SWITCH BOARD V30 M740S	6-77-M74SS-003	
8	SCREW M2*3L KI NI ICT GTY-PATCH	6-35-B1120-3RE	
9	TOUCH PAD SYNAPTICS TM-00398-001 M740S	6-49-M74S2-010	
10	TOUCH PAD SYNAPTICS TM-00398-001 M740S	6-49-M74S2-010	
11	GP BRACKET (SECC T=0.5MM) M740S	6-33-M74S2-010	

A - 4 Top without Fingerprint (M740T/M740TU)

Bottom (M740T)

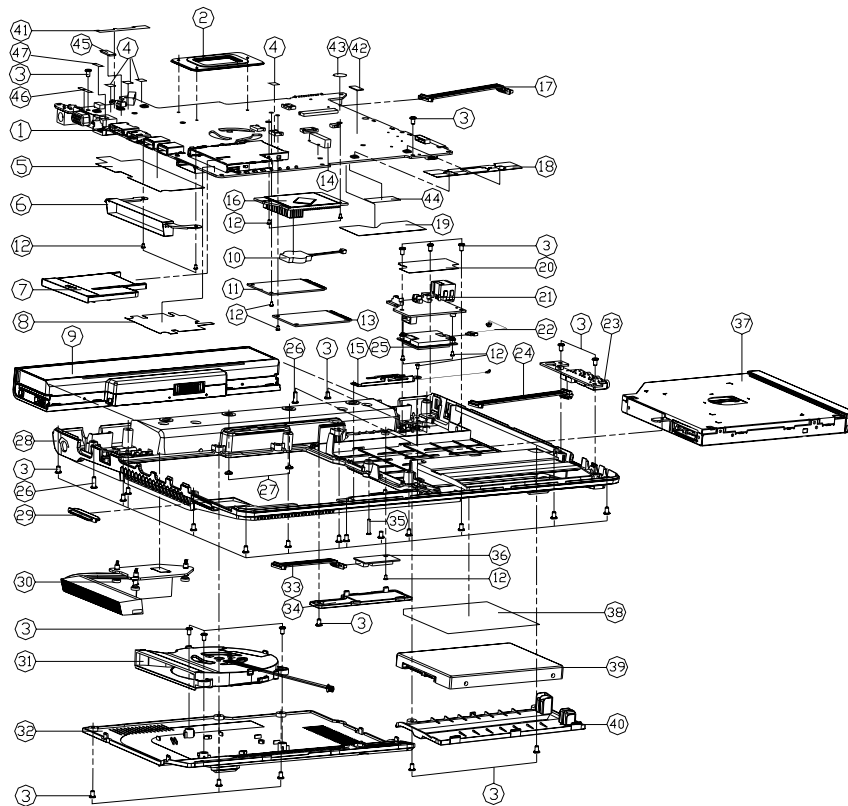

ITEM	PART	NAME	PART NO	REMARK
1	MAIN BOARD	V30B (V/D) M740T	6-77-M7410-003B	
1	MAIN BOARD	V30B (V/D) M740T	6-77-M7410-003B-I	
2	DO SUPPORT BRACKET	SS (SMD) M740T	6-33-M55NS-002	
3	SCREW	M2.5x3L KI BK/ZZ ICT NY	6-35-B612S-5RA	
4	PROTECT MB MYLAR	FRB3 M740S	6-40-M745S-020	
5	HEAT SINK MYLAR	FRB3 M740S	6-40-M745N-011	
6	FAN AIR DUCT	AL M740T	6-33-M7413-011	
7	RAMMY NEW CARD PCB ASSY	FRB3	6-42-T12R3-011	
8	NEW CARD	MYLAR FRB3 M740T	6-40-M7413-010	
9	MB VOLT REGULATOR BOARD	FRB3 M740T	6-87-M66NS-453 (OPTION)	
9	MB VOLT REGULATOR BOARD	FRB3 M740T	6-87-M745S-42A (OPTION)	
9	MB VOLT REGULATOR BOARD	FRB3 M740T	6-87-M66ES-454 (OPTION)	
9	MB VOLT REGULATOR BOARD	FRB3 M740T	6-87-M66ES-4D4 (OPTION)	
9	MB VOLT REGULATOR BOARD	FRB3 M740T	6-87-M66OS-453 (OPTION)	
9	MB VOLT REGULATOR BOARD	FRB3 M740T	6-87-M66OS-4P4 (OPTION)	
9	MB VOLT REGULATOR BOARD	FRB3 M740T	6-87-M66NS-4C3 (OPTION)	
10	MB VOLT REGULATOR BOARD	FRB3 M740T	6-23-2E01S-PRC	
11	MB VOLT REGULATOR BOARD	FRB3 M740T	6-88-M55S2-700	(OPTION)
11	MB VOLT REGULATOR BOARD	FRB3 M740T	6-88-M7212-4210	(OPTION)
11	MB VOLT REGULATOR BOARD	FRB3 M740T	6-88-M7212-4210	(OPTION)
12	SCREW	M2.5x3L KI NY ICT NY	6-35-B1120-3RA	
13	MB VOLT REGULATOR BOARD	FRB3 M740T	6-88-M72S-W-720	(OPTION)
14	TOUCH PAD SPRING	COB(SMD) OR M740S	6-47-0019A-209	
15	MB VOLT REGULATOR BOARD	FRB3 M740T	6-23-7M741-010	
16	MB VOLT REGULATOR BOARD	FRB3 M740T	6-31-M741N-011	
17	MB VOLT REGULATOR BOARD	FRB3 M740T	6-43-M745O-010	
18	FINGER BOARD	MYLAR FRB3 M740S	6-40-M745S-011	
19	DDR RAM	MYLAR FRB3 M740T	6-40-M741S-010	
20	MDC	MYLAR FRB3 M740S	6-40-M745U-010	
21	MULTI I/O BOARD	V30 M740S	6-77-M7451-003	
22	MB VOLT REGULATOR BOARD	FRB3 M740T	6-43-M745U-010	
23	MB VOLT REGULATOR BOARD	FRB3 M740T	6-77-M745A-003A	
24	MB VOLT REGULATOR BOARD	FRB3 M740T	6-43-M745O-021	
25	MB VOLT REGULATOR BOARD	FRB3 M740T	6-88-L3911-5300 (OPTION)	
26	SCREW	M2.5x3L KI BK/ZZ NY ICT NY	6-35-B612S-5RA	
27	SCREW	M2.5x3L KI BK/ZZ NY ICT NY	6-35-B6120-2RE	
28	BOTTOM CASE	MODULE M740S	6-39-M7453-013	
29	HSSG CARD	READER RUBBER	6-47-M652B-010	
30	CPU THERMAL MODULE	AL M740T	6-31-M741S-100	
31	FAN MODULE	M740S	6-31-M745S-101	
32	CPU COVER	MODULE M740S	6-42-M745S-102	
33	MB VOLT REGULATOR BOARD	FRB3 M740T	6-43-M745B-010 (OPTION)	
34	BLEEDING COVER	PCB ASSY M740S	6-42-M745B-010	
35	SCREW	M2.5x3L KI BK/ZZ ICT NY	6-35-B6120-100	
36	BLEEDING COVER	PCB ASSY M740S	6-88-M5543-620	(OPTION)
36	BLEEDING COVER	PCB ASSY M740S	6-88-M5543-390 (OPTION)	
37	SATA DVD DRIVE	ASSY M740T	6-79-M7401000-000 (OPTION)	
37	SATA DVD DRIVE	ASSY M740T	6-79-M7401000-010 (OPTION)	
38	PRODUCT LABEL	FOR M740T	6-45-M7413-010	
38	PRODUCT LABEL	FOR M741T	6-45-M741T-010	
38	PRODUCT LABEL	FOR M745T	6-45-M745T-010	
38	PRODUCT LABEL	FOR M746T	6-45-M746T-010	
39	W/D HDD ASSY	M740S	6-79-M740500-J-010	
40	HDD COVER	MODULE M740S	6-42-M745J-102	
41	MB VOLT REGULATOR BOARD	FRB3 M740T	6-40-M745S-06A	
42	MB VOLT REGULATOR BOARD	FRB3 M740S	6-40-M745S-030	
43	MYLAR	DID FRB3 M740S	6-40-M765O-010	
44	TAPE MYLAR	CA MYLAR M550J	6-40-M55J2-010	
45	MB TOP RUBBER	SILICONE M740T	6-47-M741S-030	
46	E-STAT	RESISTOR FOR MB M740T	6-47-M741S-010	
47	MB TOP RUBBER	SILICONE FOR MB M740T	6-47-M741S-020	

Figure A - 3
Bottom (M740T)

A.Part Lists

Bottom (M740TU)

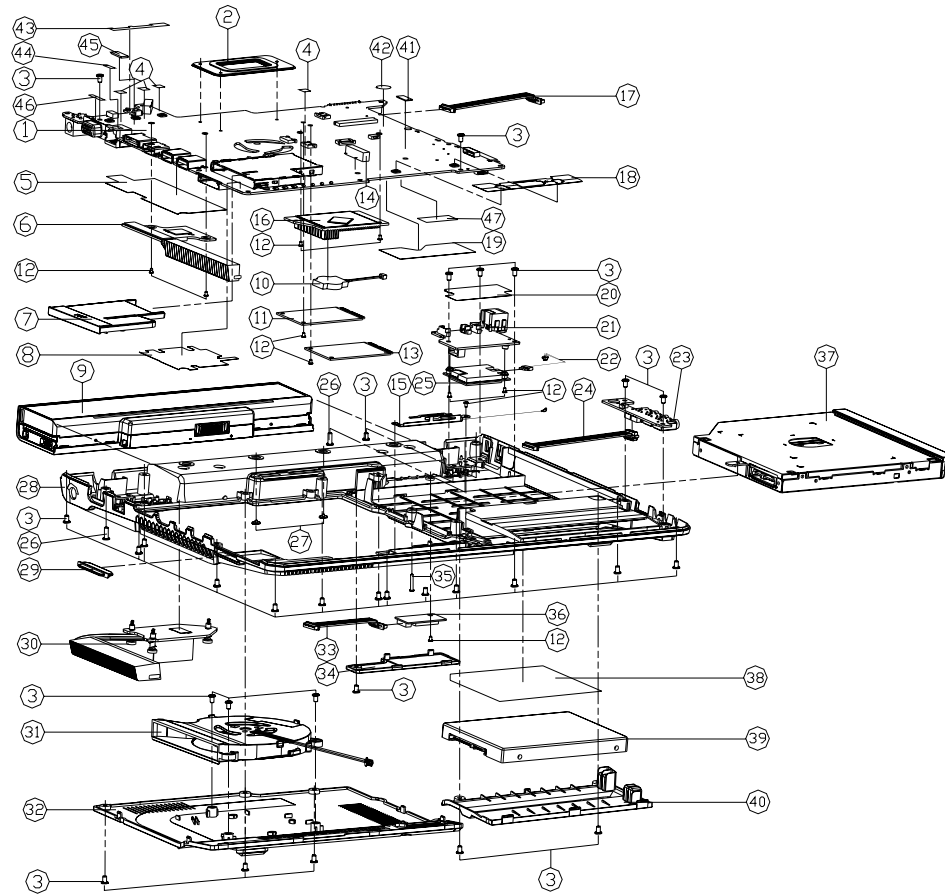
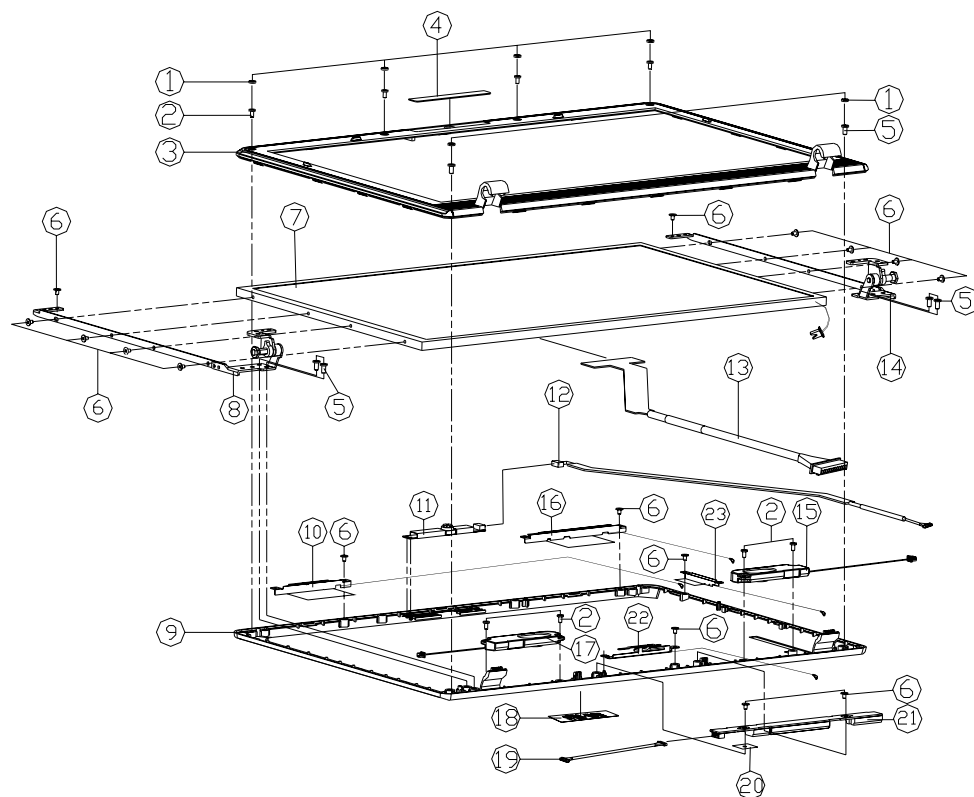

Figure A - 4
Bottom (M740TU)

ITEM	PART NAME	PART NO	REMARK
1	MAIN BOARD V308 (V/D 3D) M740TU	6-77-M740-0038-1U	
1	MAIN BOARD V308 (V/3D) M740TU	6-77-M740-0038-1U	
2	CPU SUPPORT BRACKET SUS 430C/D M55N	6-33-M55NS-022	
3	SCREW M2.5x5L KI BK/Z ICT NY-	6-35-B612S-5RA	
4	PROTECT MB MYLAR FRB3 M740S	6-40-M74SS-020	
5	HEAT SINK MYLAR FRB3 M740S	6-40-M74SN-011	
6	VGA THERMAL MIDDLE AL M740TU	6-31-M740N-100	
7	DUMMY NEW CARD PC+ABS TNE20R	6-42-T12R3-011	
8	NEW CARD MYLAR FRB3 M740TU	6-40-M74T3-010	
9	MAIN BOARD V308 (V/D 3D) M740TU	6-87-M66NS-453	(OPTION)
9	BATP S LI 108V/720H 32SP SMP/PANASCNIC	6-87-M74SS-4CA	(OPTION)
9	BATP S LI 108V/44H 32SP QLV/PANASCNIC	6-87-M6E6S-454	(OPTION)
9	BATP S LI 108V/44H 32SP QLV/PANASCNIC 72	6-87-M660S-453	(OPTION)
9	BATP S LI 111V/44H 32SP SMP/INAC-2200 9	6-87-M660S-4P4	(OPTION)
9	BATP S LI 4.4AH 32SP FOR M66N/SP /PIN	6-87-M66NS-4C3	(OPTION)
10	MAIN BOARD V308 (V/D 3D) M740TU	6-23-2201S-PC2	
11	MAIN BOARD V308 (V/D 3D) M740TU	6-88-M5SS2-7000	(OPTION)
11	MAIN BOARD V308 (V/D 3D) M740TU	6-88-M72T2-4210	(OPTION)
11	MAIN BOARD V308 (V/D 3D) M740TU	6-88-M72T2-4240	(OPTION)
12	SCREW M2x10L KI NI ICT NY	6-35-B1120-3RA	
13	YLR CARBON HEAT SINK SERRULESS M6 CAR 025 236	6-88-M72SN-720	(OPTION)
14	TOUCH PAD SPONGE (20x5x6) CR M740S	6-47-0019A-209	
15	ANTENNA VIBRO 24G/25G PIFA W/6 270MM	6-23-M74T-010	
16	NORTH BRIDGE HEAT SINK AL M740T	6-31-M74TN-011	
17	VIRE CABLE SPIN W/4 TO MULTI BOARD FOR M740S	6-43-M74S0-010	
18	FINGER BOARD MYLAR FRB3 M740S	6-40-M74SS-011	
19	DDR RAM MYLAR FRB3 M740T	6-40-M74TS-010	
20	MDC MYLAR FRB3 M740S	6-40-M74SU-010	
21	MULTI I/O BOARD V30 M740S	6-77-M74S1-003	
22	VIRE CABLE SPIN MULTI BOARD TO MC MODULE FOR M740S	6-43-M74SU-010	
23	PHONE JACK & USB BOARD V30A M740S	6-77-M74SA-003A	
24	VIRE CABLE SPIN W/4 TO AUDIO BOARD FOR M740S	6-43-M74S0-021	
25	MAIN BOARD V308 (V/D 3D) M740TU	6-88-L39T1-5300	(OPTION)
26	SCREW M2.5x5L KI BK/Z NY ICT	6-35-B612S-6R0	
27	SCREW M2x5L KI BK/Z ICT NY(08.1+0.6)	6-35-B6120-2RE	
28	BOTTOM CASE MODULE M740S	6-39-M74S3-013	
29	M520G CARD READER RUBBER	6-47-M52GB-010	
30	CPU THERMAL MIDDLE AL M740T	6-31-M74TS-100	
31	FAN MIDDLE M740S	6-31-M74SS-101	
32	CPU COVER MODULE M740S	6-42-M74SS-102	
33	VIRE CABLE SPIN W/4 TO SPIN BLUE TOOTH MODULE FOR M740S	6-43-M74SB-010	(OPTION)
34	BLUETOOTH COVER PC+ABS(C6440) M740S	6-42-M74SB-010	
35	SCREW M2x10L KI BK/Z ICT NY	6-35-B6120-100	
36	BLUETOOTH V20 OPTICOM 060 02CM 8 PIN USB	6-88-M5S4S-620	(OPTION)
36	BLUETOOTH V20 OPTICOM 060 02CM 8 PIN USB	6-88-M5S4S-390	(OPTION)
37	SATA DVD SUPER MULTI OPTICOM M740T	6-79-M74T000-000	(OPTION)
37	SATA DVD COMBO ASSY OPTICOM M740T	6-79-M74T000-000	(OPTION)
38	PRODUCT LABEL FOR M740TU	6-45-M7403-010	
39	W/D HDD ASS'Y M740S	6-79-M74SS0J-010	
40	HDD COVER MODULE M740S	6-42-M74SJ-102	
41	MC MYLAR FRB3 TERA040SP M740S	6-40-M74SS-030	
42	MYLAR DIO FRB3 M740S	6-40-M76S0-010	
43	MC MYLAR FRB3 TERA040SP M740S	6-40-M74SS-060	
44	MC MYLAR FRB3 TERA040SP M740S	6-47-M74TS-020	
45	MB TOP RUBBER SILICONE M740T	6-47-M74TS-030	
46	E-STAT M740S (M520G) FOR W/D M740T	6-47-M74TS-010	
47	TAPE MYLAR (A) MYLAR M550J	6-40-M55J2-010	

LCD (M740T/M740TU)



ITEM	PART NAME	PART NO	REMARK
1	LCD FRONT COVER SCREW HOLE RUBBER WEDGE	6-47-M72S1-021	
2	SCREW HEX. 1.8X 1.2 CT GR-PATCH (180 B-4)	6-35-C6120-46B	
3	LCD FRONT COVER MODULE M740S	6-39-M74S1-012	
4	CCD LINES (PMMA) M740S	6-42-M74S1-010	FOR CCD
4	CCD LINES (FR700) M740S	6-42-M74S1-020	FOR W/D CCD
5	SCREW M2.5X5L KI BK/Z CT NY	6-35-B6125-5RA	
6	SCREW M2X3L KI NI CT GR-PATCH	6-35-B1120-3RE	
7	LCD HAT VIGA AU BUREN V1 GLARE TYPE SSAM	6-50-JC255-G05	(OPTION)
7	LCD HAT VIGA CHINEI M403-LUS SSAM	6-50-JC255-D07	(OPTION)
7	LCD HAT VIGA CHINEI M403-LUS SSAM	6-50-JC255-D06	(OPTION)
7	LCD HAT VIGA CHINEI M403-LUS SSAM	6-50-J7255-D04	(OPTION)
7	LCD HAT VIGA AU BUREN V1 SSAM	6-50-J7255-G00	(OPTION)
7	LCD HAT VIGA CHINEI M403-LUS SSAM	6-50-J7255-D05	(OPTION)
8	LCD HINGE L (SECC-SK7) M740S	6-33-M74S1-022	
9	LCD BACK COVER MODULE M740S	6-39-M74S1-021	
10	ANTENNA VIGA 2X6.2X3.5 PPA VIG SSAM	6-23-7M74S-020	
11	UV CAMERA BUSH FOR BUSHLET ON THE M740TU	6-88-M740C-4921	FOR M740T(OPTION)
11	UV CAMERA BUSH FOR BUSHLET ON THE M740TU	6-88-M740C-4911	FOR M740TU(OPTION)
12	WIRE CABLE SPIN W/O TO CCD ZR325MM HOLE	6-43-M74S1-011	FOR CCD
13	WIRE CABLE SPIN W/O TO CCD ZR325MM FOR W40S	6-43-M74S1-010	
14	LCD HINGE R (SECC-SK7) M740S	6-33-M74S1-012	
15	SPR. CABLE SSAM (5) OF PFC-250MM R-LIKE W40S	6-23-5M74S-011	
16	ANTENNA VIGMA 3X PPA 45MM	6-23-7M74S-010	(OPTION)
17	SPR. CABLE SSAM (5) OF PFC-250MM R-LIKE W40S	6-23-5M74S-021	
18	STRIP-NOISE-1100	6-45-M74S1-012	
19	WIRE CABLE FOR W/O TO INVERTER BOARD L-PH W40S	6-43-M74SR-011	
20	INVERTER W/LAB (FR50-NETTON) SSAM W40S	6-40-M76S1-010	
21	BUSHLET HOLE IN WIRE IN HOLE COVER HOLE IN W40S	6-76-M666R-010	(OPTION)
21	BUSHLET HOLE IN WIRE IN HOLE COVER HOLE IN W40S	6-76-M666R-011	(OPTION)
22	ANTENNA VIGA 2X6.2X3.5 PPA VIG SSAM	6-23-7M74T-021	(OPTION)
23	ANTENNA BUSHLET 2.6X PPA BT 25MM	6-23-7M74S-030	(OPTION)

Figure A - 5
LCD (M740T/
M740TU)

A.Part Lists

HDD (M740T/M740TU)

Figure A - 6
HDD
(M740T/M740TU)

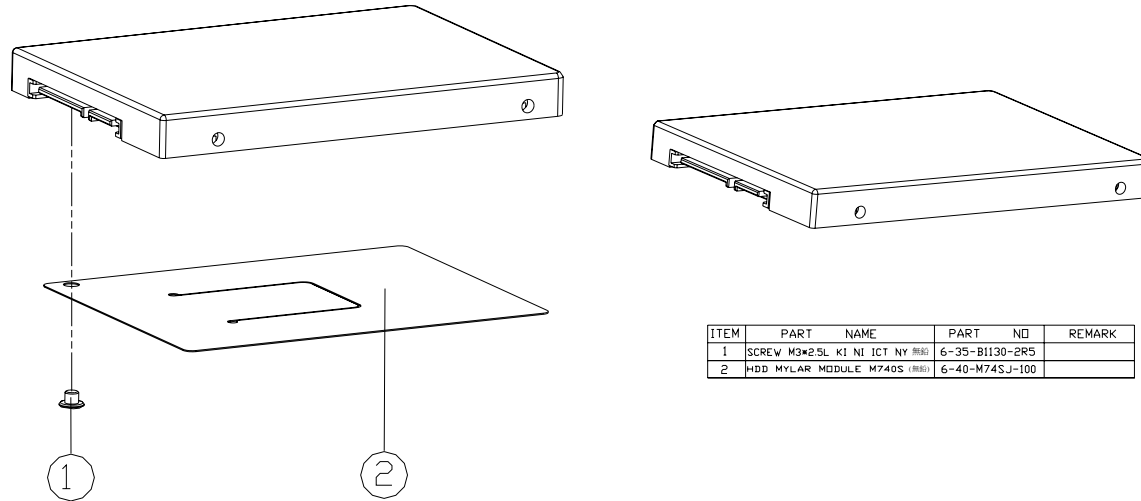

ITEM	PART NAME	PART NO	REMARK
1	SCREW M3*2.5L K1 NI ICT NY (R6)	6-35-B1130-2R5	
2	HDD MYLAR MODULE M740S (R6)	6-40-M74SJ-100	

COMBO (M740T/M740TU)

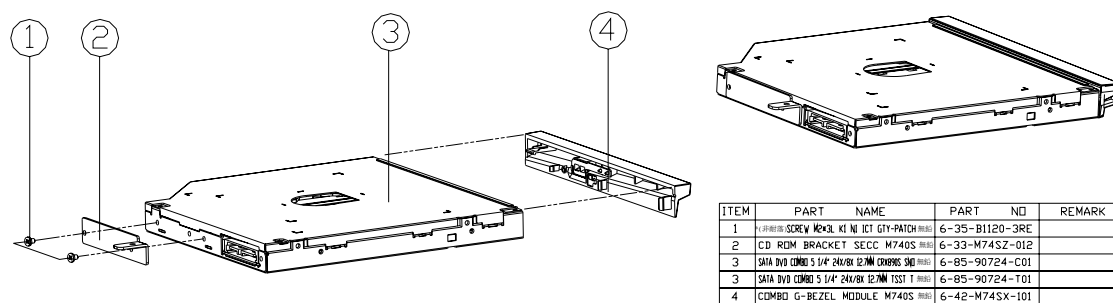

Figure A - 7
COMBO
(M740T/M740TU)

ITEM	PART NAME	PART NO	REMARK
1	SCREW M2X3L KI NI ICT GTY-PATCH	6-35-B1120-3RE	
2	CD ROM BRACKET SECC M740S	6-33-M74SZ-012	
3	SAHA DVD COMBO 5 1/4" 24X/8X 12.7MM COMBOS 3RD	6-85-90724-C01	
3	SAHA DVD COMBO 5 1/4" 24X/8X 12.7MM TSST T	6-85-90724-T01	
4	COMBO G-BEZEL MODULE M740S	6-42-M74SX-101	

A.Part Lists

DVD-Dual Drive (M740T/M740TU)

Figure A - 8
**DVD-Dual Drive
(M740T/M740TU)**

Top with Fingerprint (M760T/M760TU)

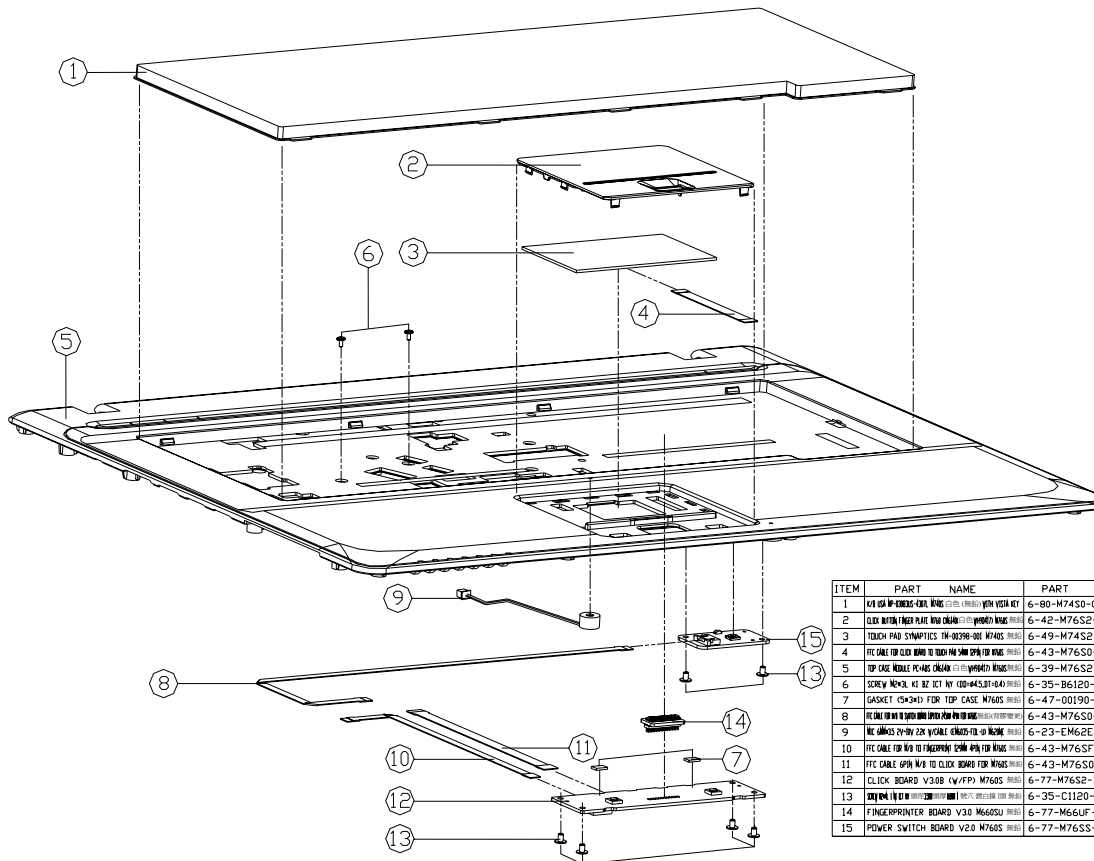

Figure A - 9
Top with
Fingerprint
(M760T/M760TU)

ITEM	PART NAME	PART NO	REMARK
1	TOP WITH FINGERPRINT BOARD (M760T/M760TU)	6-80-M7450-011-1	
2	CLICK BOARD V3.0B (W/FP)	6-42-M76S2-012	
3	TOUCH PAD SYNAPTICS TM-00398-001 M760S	6-49-M74S2-010	
4	FTC CABLE FOR CLICK BOARD TO TOUCH PAD (M760T/M760TU)	6-43-M76S0-041	
5	TOP CASE MIDDLE PEAKS CLEAN (M760T/M760TU)	6-39-M76S2-013	
6	SCREW M4X4 KI BZ TCT NY (00-445,31-04)	6-35-B6120-3RD	
7	GASKET (5X34) FOR TOP CASE M760S	6-47-00190-05K	
8	FTC CABLE FOR WIRELESS CHARGING (M760T/M760TU)	6-43-M76S0-031	
9	FTC CABLE FOR WIRELESS CHARGING (M760T/M760TU)	6-23-EM62E-010	
10	FTC CABLE FOR WIRE TO CLICK BOARD (M760T/M760TU)	6-43-M76SF-011	
11	FTC CABLE FOR WIRE TO CLICK BOARD (M760T/M760TU)	6-43-M76S0-011	
12	CLICK BOARD V3.0B (W/FP) M760S	6-77-M76S2-003B	
13	CLICK BOARD V3.0B (W/FP) M760S	6-35-C1120-4RB	
14	FINGERPRINTER BOARD V3.0 M660SU	6-77-M66UF-002	
15	POWER SWITCH BOARD V2.0 M760S	6-77-M76SS-002	

A.Part Lists

Part Lists

Top without Fingerprint (M760T/M760TU)

A.Part Lists

Figure A - 10
Top without
Fingerprint
(M760T/M760TU)

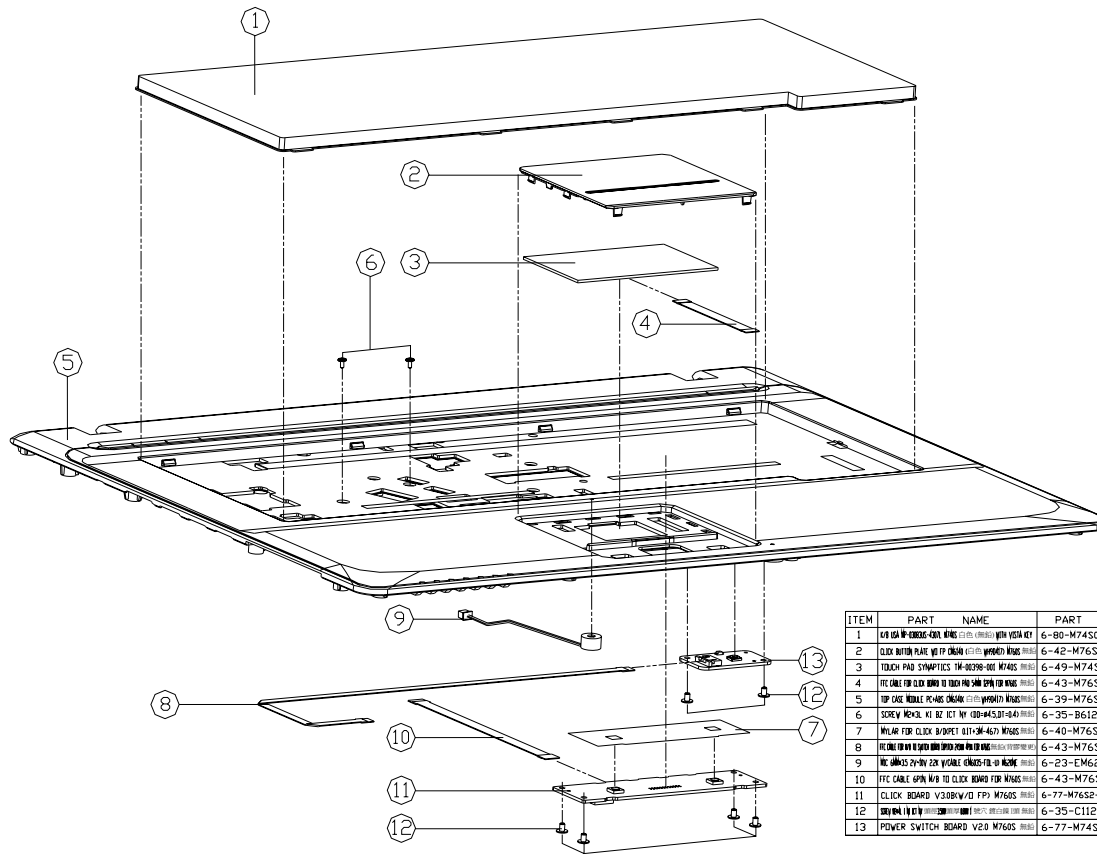

ITEM	PART NAME	PART NO	REMARK
1	TOP CASE W/ CAMERA, FINGER PRINT SENSOR, MIC, VIBRA MOTOR	6-00-M7450-011-1	
2	CLICK BUTTON PLATE W/ FP SENSOR (FOR W/ FP SENSOR)	6-42-M7652-0B2	
3	TOUCH PAD SYNAPTICS 5W-00390-001 M760S	6-49-M7452-010	
4	IPC CABLE FOR CLICK BOARD TO TOUCH PAD (FOR W/ FP SENSOR)	6-43-M7650-041	
5	TOP CASE MIDDLE FRAME CHASSIS (FOR W/ FP SENSOR)	6-39-M7652-013	
6	SCREW M2X3.5 L1.8Z ICT NY 100-44530-10-00	6-35-B6120-3RD	
7	W/ LAR FOR CLICK B/P/FPET 011-06-4670 M760S	6-40-M765S-040	
8	IPC CABLE FOR W/ FP SENSOR BOARD TO TOUCH PAD (FOR W/ FP SENSOR)	6-43-M7650-031	
9	IPC CABLE 2X-2W 22X VIOLETT (FOR W/ FP SENSOR)	6-23-EM62E-010	
10	IPC CABLE 4PIN W/ 100 CLICK BOARD FOR W/ FP SENSOR	6-43-M7650-011	
11	CLICK BOARD V3.08K/01 FP3 M760S	6-77-M7652-003B-1	
12	SCREW M2X3.5 L1.8Z ICT NY 100-44530-10-00	6-35-C1120-4RB	
13	POWER SWITCH BOARD V2.0 M760S	6-77-M745S-102	

A - 12 Top without Fingerprint (M760T/M760TU)

Bottom (M760T)

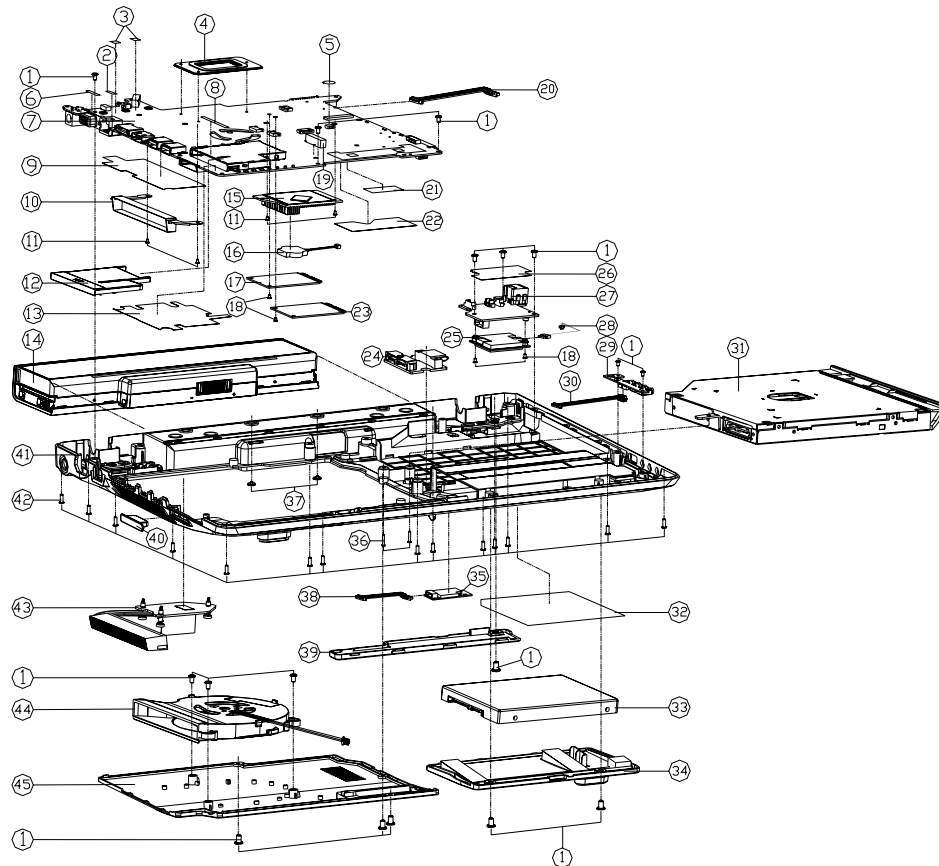

ITEM	PART NAME	PART NO	REMARK
1	SCREW M2.5x0.4 KI BK/Z ICT NY-#000	6-35-B6125-5RA	
2	HDD COVER (OPT) FOR M760T	6-47-M74TS-020	
3	PROTECT MB MYLAR FR83 M740S	6-40-M74SS-020	
4	CPU SUPPORT BRACKET SUS 430C/D M50N	6-33-M55NS-022	
5	MYLAR D10 FR83 M760S	6-40-M76S0-010	
6	E-STAT FOR M760T	6-47-M74TS-010	
7	MAIN BOARD V30B (w/3G) M760T	6-77-M76T0-D03B	
8	HEAT SINK MYLAR FR83 M740S	6-47-M74SN-011	
9	FAN AIR DUCT AL M740T	6-33-M74T3-011	
10	SCREW M2x3L KI NI ICT NY-#000	6-35-B1120-3RA	
11	DUMMY NEW CARD PC+ABS T120R	6-42-T12R3-011	
12	NEW CARD MYLAR FR83 M740T	6-40-M74T3-010	
13	BATTERY 3.7V 440mAh 32P GALV/PANASONIC	6-87-M66NS-453	(OPTION)
14	BATTERY 3.7V 440mAh 32P GALV/PANASONIC	6-87-M66NS-454	(OPTION)
14	BATTERY 3.7V 440mAh 32P GALV/PANASONIC	6-87-M66NS-453	(OPTION)
14	BATTERY 3.7V 440mAh 32P GALV/PANASONIC	6-87-M66NS-454	(OPTION)
14	BATTERY 3.7V 440mAh 32P GALV/PANASONIC	6-87-M66NS-453	(OPTION)
14	BATTERY 3.7V 440mAh 32P GALV/PANASONIC	6-87-M66NS-454	(OPTION)
15	NORTH BRIDGE HEAT SINK AL M740T	6-31-M74TN-012	
16	HEAT SINK MYLAR FR83 M740S	6-40-M74SN-011	
17	HEAT SINK MYLAR FR83 M740S	6-40-M74SN-011	
17	HEAT SINK MYLAR FR83 M740S	6-40-M74SN-011	
17	HEAT SINK MYLAR FR83 M740S	6-40-M74SN-011	
18	TOUCH PAD SPENGE (20x56) CR M740S	6-47-0019A-209	
19	WIRE CABLE SUPPLY W/O TO MULTI BOARD TANK FOR M760S	6-43-M76S0-022	
20	TAPE MYLAR (A)MYLAR M550J	6-40-M55J2-010	
21	DDR RAM MYLAR FR83 M740T	6-40-M74TS-010	
22	WIRE CABLE SUPPLY W/O TO MULTI BOARD TANK FOR M760S	6-43-M76S0-022	
23	WIRE CABLE SUPPLY W/O TO MULTI BOARD TANK FOR M760S	6-43-M76S0-022	
24	DDR BRIDGE BOARD V30 M760T	6-77-M76TN-D03	
25	WIRE CABLE SUPPLY W/O TO MULTI BOARD TANK FOR M760S	6-43-M76S0-022	
26	MDC MYLAR FR83 M740S	6-40-M74SU-010	
27	MULTI I/O BOARD V30 M740S	6-77-M74SI-D03	
28	WIRE CABLE SUPPLY W/O TO MULTI BOARD TANK FOR M760S	6-43-M76S0-022	
29	PHONE JACK & USB BOARD V30A M740S	6-77-M74SA-D03A	
30	WIRE CABLE SUPPLY W/O TO MULTI BOARD TANK FOR M760S	6-43-M76S0-022	
31	SATA DVD SUPER MULTI ASSY(OPTION) M760T	6-79-M76T000-000	(OPTION)
31	SATA DVD SUPER MULTI ASSY(OPTION) M760T	6-79-M76T000-000	(OPTION)
32	PRODUCT LABEL FOR M760T	6-45-M76T3-010	
32	PRODUCT LABEL FOR M765T	6-45-M765T-010	
32	PRODUCT LABEL FOR M766T	6-45-M766T-010	
32	PRODUCT LABEL FOR M767T	6-45-M767T-010	
33	W/D HDD ASS'Y M760S	6-79-M76S00J-010	
34	HDD COVER MODULE (OPT) M760S	6-42-M76SJ-102	
35	BLUETOOTH V2.0 (OPTION) 4000mAh 8 PIN USB	6-88-M5545-620	(OPTION)
35	BLUETOOTH V2.0 (OPTION) 4000mAh 8 PIN USB	6-88-M5545-390	(OPTION)
36	SCREW M2x0.4 KI BK/Z ICT NY-#000	6-35-B6120-BR0	
37	SCREW M2x0.4 KI BK/Z ICT NY-#000	6-35-B6120-2RE	
38	WIRE CABLE SUPPLY W/O TO MULTI BOARD TANK FOR M760S	6-43-M76S0-022	(OPTION)
39	BT COVER MODULE (OPT) M760S	6-42-M76SB-101	
40	WIRE CABLE SUPPLY W/O TO MULTI BOARD TANK FOR M760S	6-43-M76S0-022	
41	WIRE CABLE SUPPLY W/O TO MULTI BOARD TANK FOR M760S	6-43-M76S0-022	
42	SCREW M2.5x0.4 KI BK/Z ICT NY-#000	6-35-B6125-BR0	
43	CPU THERMAL MODULE AL M740T	6-31-M74TS-100	
44	FAN MODULE M740S	6-31-M74SS-101	
45	CPU COVER MODULE M760S	6-42-M76SS-102	

Figure A - 11
Bottom (M760T)

A.Part Lists

Part Lists

Bottom (M760TU)

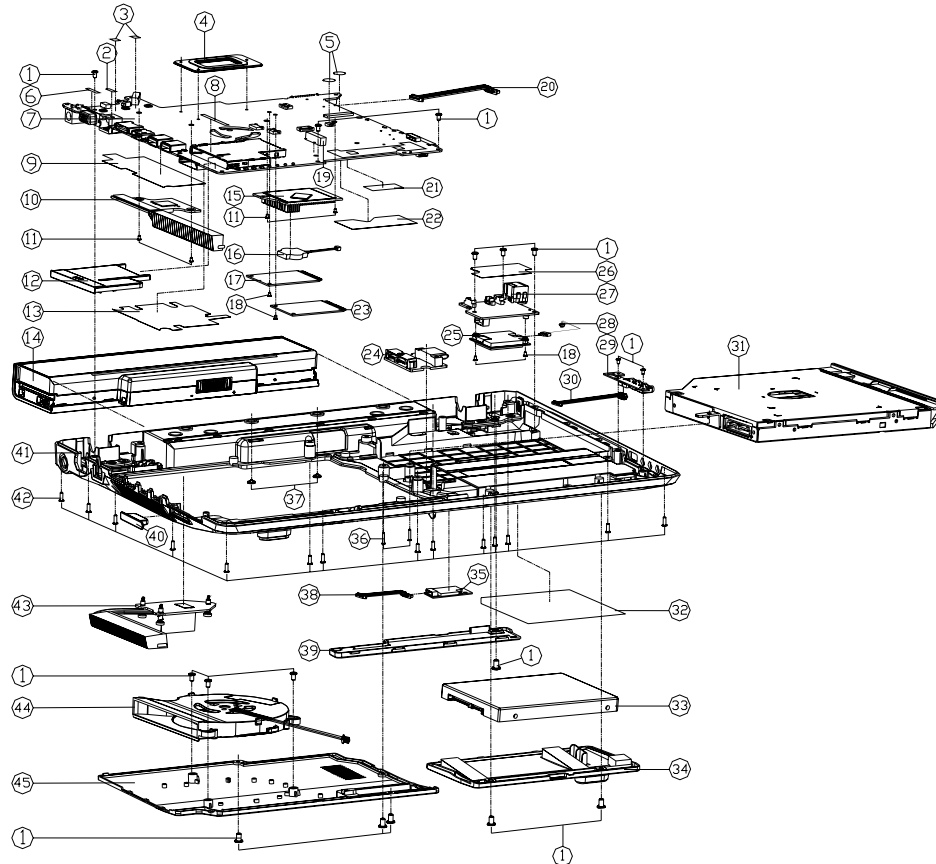

Figure A - 12
Bottom (M760TU)

A.Part Lists

ITEM	PART NAME	PART NO	REMARK
1	SCREW M2.5*5L KI BK/2 ICT NY-1000	6-35-B6125-5RA	
2	HME (04V54025) FOR M760T	6-47-M74TS-020	
3	MYLAR 5x2.5x1ST (FR83-3467) M760S	6-40-M76SS-030	
4	CPU SUPPORT BRACKET SUS 430C/D M50N	6-33-M55NS-022	
5	MYLAR D10 FR83 M760S	6-40-M76S0-010	
6	E-STAT (04S4025) FOR M760T	6-47-M74TS-010	
7	MAIN BOARD V30B (W/3G) M760TU	6-77-M76T0-003B-U	
8	HEAT SINK AL FOR NEW CARD BOX M760T	6-47-M76TS-010	
9	HEAT SINK MYLAR FR83 M740S	6-40-M74SN-011	
10	VGA THERMAL MODULE AL M740TU	6-31-M740N-100	
11	SCREW M2*3L KI NI ICT NY-1000	6-35-B1120-3RA	
12	DUMMY NEW CARD PC+ABS T12R3	6-42-T12R3-011	
13	NEW CARD MYLAR FR83 M740T	6-40-M74T3-010	
14	BATP SLI 108V/44W 32SP QLY/PANSONIC	6-87-M66US-4DE (OPTION)	
14	BATP SLI 108V/44W 32SP QLY/PANSONIC 98	6-87-M66S-4D4 (OPTION)	
14	BATP SLI 108V/44W 32SP QLY/PANSONIC 72	6-87-M66S-453 (OPTION)	
14	BATP SLI 108V/44W 32SP QLY/PANSONIC 200 9	6-87-M66S-4P4 (OPTION)	
14	BATP SLI 40W 32SP FOR M66US/SP/PAN	6-87-M66NS-4C3 (OPTION)	
15	NORTH BRIDGE HEAT SINK AL M740T	6-31-M74TN-012	
16	HEAT SINK AL FOR CPU	6-23-22015-P2C	
17	HEAT SINK AL FOR GPU	6-88-M55SS-7000 (OPTION)	
17	HEAT SINK AL FOR GPU	6-88-M72T2-4210 (OPTION)	
17	HEAT SINK AL FOR GPU	6-88-M72T2-4240 (OPTION)	
17	HEAT SINK AL FOR GPU	6-88-M72T2-4241 (OPTION)	
17	HEAT SINK AL FOR GPU	6-88-M72T2-4241 (OPTION)	
18	TOUCH PAD SPONGE (20x54x6) CR M740S	6-35-B1120-3RD	
19	TOUCH PAD SPONGE (20x54x6) CR M740S	6-47-0019A-209	
20	YRE CABLE EPN W/6 TO MULTI BOARD DIM FOR M66S	6-43-M76S0-022	
21	TAPE MYLAR (A) MYLAR M550J	6-40-M55J2-010	
22	DDR RAM MYLAR FR83 M740T	6-40-M74TS-010	
23	YRE CABLE EPN W/6 TO MULTI BOARD DIM FOR M66S	6-88-M72SW-720 (OPTION)	
24	DDD BRIDGE BOARD V30 M760T	6-77-M76TN-003	
25	HEAT SINK AL FOR GPU	6-88-L39T11-5300 (OPTION)	
26	MDC MYLAR FR83 M740S	6-40-M74S1-010	
27	MULTI I/O BOARD V30 M740S	6-77-M74S1-003	
28	YRE CABLE EPN W/6 TO MULTI BOARD DIM FOR M66S	6-43-M76S0-052	
29	PHONE JACK & USB BOARD V30A M740S	6-77-M74SA-003A	
30	YRE CABLE EPN W/6 TO MULTI BOARD DIM FOR M66S	6-43-M74S1-010	
31	SATA DVD COMBO ASSY (OPTION) M760T	6-79-M76T000-000 (OPTION)	
31	SATA DVD COMBO ASSY (OPTION) M760T	6-79-M76T000-000 (OPTION)	
32	PRODUCT LABEL FOR M760TU	6-45-M76TU-010	
32	PRODUCT LABEL FOR M765TU	6-45-M76TU03-010	
33	W/D HDD ASS'Y M760S	6-79-M76S00J-010	
34	HDD COVER MODULE (04V54025) M760S	6-42-M76S0J-102	
35	BLUE TOOTH V2.0 OPTION AND W/6 PIN USB	6-88-M5445-620 (OPTION)	
35	BLUE TOOTH V2.0 OPTION AND W/6 PIN USB	6-88-M5445-390 (OPTION)	
36	SCREW M2*3L KI BK/2 ICT NY-1000	6-35-B6120-6R0	
38	YRE CABLE EPN W/6 TO MULTI BOARD DIM FOR M66S	6-35-B6120-2RE	
39	BT COVER MODULE (04V54025) M760S	6-42-M76SS-101 (OPTION)	
40	HEAT SINK AL FOR GPU	6-47-M76SS-010	
41	HEAT SINK AL FOR GPU	6-39-M76SS-012	
42	SCREW M2*3L KI BK/2 ICT NY-1000	6-35-B6125-6R0	
43	CPU THERMAL MODULE AL M740T	6-31-M74TS-100	
44	FAN MODULE M740S	6-31-M74SS-101	
45	CPU COVER MODULE M760S	6-42-M76SS-102	

A - 14 Bottom (M760TU)

LCD (M760T/M760TU)

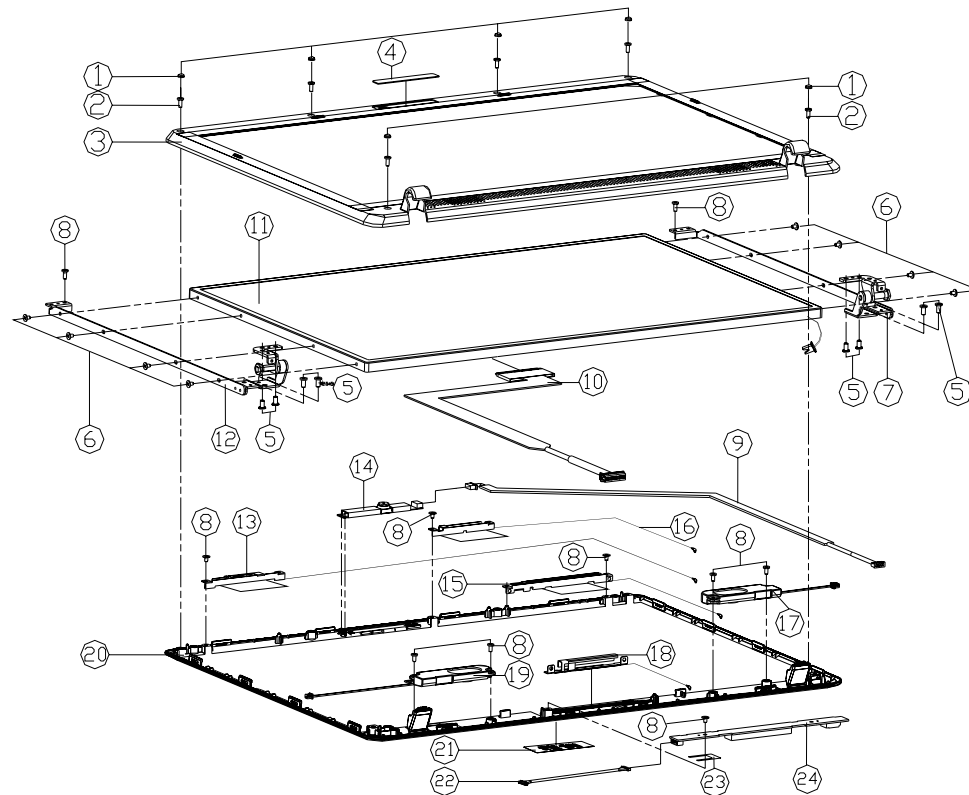

ITEM	PART NAME	PART NO	REMARK
1	LCD FRONT COVER BEZEL UPPER 3-4MM T-1.0MM W/MS	6-47-M76S1-010	
2	SCREW NEXOL KIT108 3-4D BK/Z ICT NY	6-35-B6120-SR0	
3	LCD FRONT COVER MODULE M760S	6-39-M76S1-011	
4	CCD COSMETIC PMMA T-0.5MM M760S	6-42-M76S1-031	W/ CCD
4	W/D CCD COSMETIC 6ST PMMA M760S	6-42-M76S1-040	W/D CCD
5	SCREW M2.5X5L KI BK/Z ICT NY	6-35-B6125-SRA	
6	ALUMINUM SCREW NEXOL KI NI ICT 01-PH010	6-35-B1120-3RE	
7	LCD HINGE-R SECC M760S	6-33-M76S1-011	
8	BEZEL HINGE M760S	6-35-C1120-4RB	
9	VIC CABLE SPIN W/O TO CCD FRONT MODULE FOR W/MS	6-43-M76S1-021	FOR CCD
10	VIC CABLE SPIN W/O TO LCD FRONT FOR W/MS	6-43-M76S1-010	
11	LCD ISF VISA+ CHNKT NS424-02 GLARE TYPE	6-50-L7261-G01	(OPTION)
11	LCD ISF VISA+ CHNKT NS424-02 GLARE TYPE	6-50-L7265-D00	(OPTION)
11	LCD ISF VISA+ CHNKT NS424-02 GLARE TYPE	6-50-LA265-D00	(OPTION)
11	LCD ISF VISA+ CHNKT NS424-02 GLARE TYPE	6-50-LC264-G00	(OPTION)
11	LCD ISF VISA+ CHNKT NS424-02 GLARE TYPE	6-50-LC261-G00	(OPTION)
11	LCD ISF VISA+ CHNKT NS424-02 GLARE TYPE	6-50-LC263-G00	(OPTION)
11	LCD ISF VISA+ CHNKT NS424-02 GLARE TYPE	6-50-LC265-D00	(OPTION)
12	LCD HINGE-L SECC M760S	6-33-M76S1-021	
13	ANTENNA W/AN 24G/30G/PPA W/O IL-AC00	6-23-7M76S-010	
14	VIC CABLE SPIN FOR BEZEL/ANTENNA TO LCD FRONT	6-98-M740C-4921	FOR W/MS1-(1)OPTION
14	VIC CABLE SPIN FOR BEZEL/ANTENNA TO LCD FRONT	6-98-M740C-4911	FOR W/MS1(2)OPTION
15	ANTENNA VCSMA 36 PIFA 45MM	6-23-7M76S-040	(OPTION)
16	BEZEL HINGE L&R W/O W/MS	6-23-7M76S-051	(OPTION)
17	SPR CABLE SPIN FOR BEZEL/ANTENNA TO LCD FRONT	6-23-5M74S-030	
18	ANTENNA W/AN 24G/30G/PPA W/O IL-AC00	6-23-7M76S-021	(OPTION)
19	SPR CABLE SPIN FOR BEZEL/ANTENNA TO LCD FRONT	6-23-5M74S-042	
20	LCD BACK COVER MODULE M760S	6-39-M76S1-021	FOR M760S-T
20	BACK COVER MODULE W/D FOIL W/MS-C	6-39-M76S1-020-C	FOR M760S-C
20	LCD BACK COVER MODULE W/D SUP W/MS	6-39-M7621-021	FOR M762S
21	SPR CABLE FOR W/O TO INVERTER BOARD C PIN W/MS	6-45-M74S1-012	
22	VIC CABLE FOR W/O TO INVERTER BOARD C PIN W/MS	6-43-M74SR-011	
23	INVERTER W/AN 0.055W/100V 500V W/MS	6-40-M76S1-010	
24	BEZEL HINGE L&R W/O W/MS	6-76-M6R6R-010	(OPTION)
24	BEZEL HINGE L&R W/O W/MS	6-76-M660R-011	(OPTION)

Figure A - 13
LCD (M760T/
M760TU)

HDD (M760T/M760TU)

Figure A - 14
HDD
(M760T/M760TU)

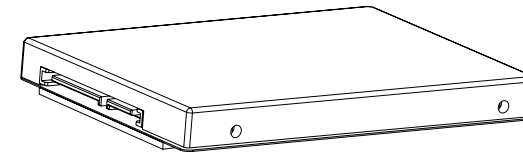
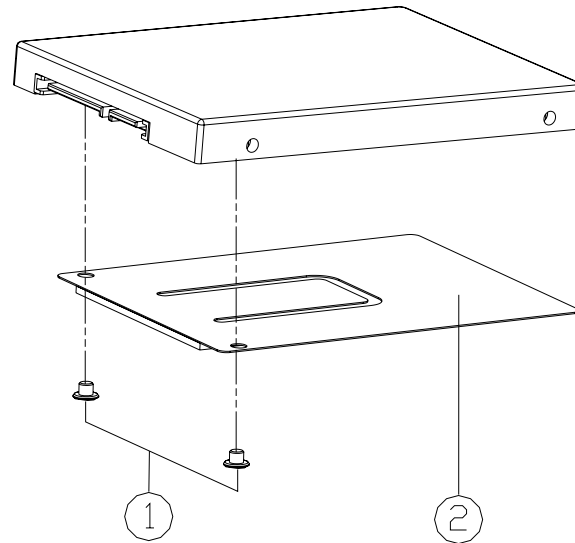

ITEM	PART NAME	PART NO	REMARK
1	SCREW M3*2.5L K1 NI ICT NY 0000	6-35-B1130-2R5	
2	HDD MYLAR MODULE M760S (0000)	6-40-M76SJ-100	

COMBO (M760T/M760TU)

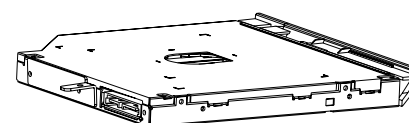
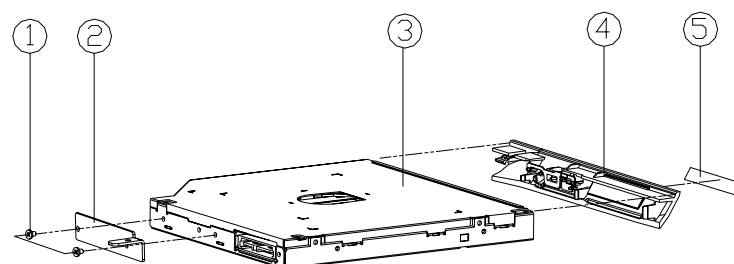

ITEM	PART NAME	PART NO	REMARK
1	SCREW NEXOL KI NI ICT GY-PATCH	6-35-B1120-3RE	
2	CD ROM BRACKET SECC M740S	6-33-M74SZ-012	
3	SATA DVD COMBO 5.14" 24X/8X 12.7MM CR699	6-85-90724-C01	
3	SATA DVD COMBO 5.14" 24X/8X 12.7MM ISSI T	6-85-90724-T01	
4	ODD BEZEL MODULE <M760S>	6-42-M76SZ-102	
5	ODD BEZEL LABEL(COMBO) FOR M760S	6-45-M76SX-011	

Figure A - 15
COMBO
(M760T/M760TU)

A.Part Lists

DVD-Dual Drive (M760T/M760TU)

Figure A - 16
DVD-Dual Drive
(M760T/M760TU)

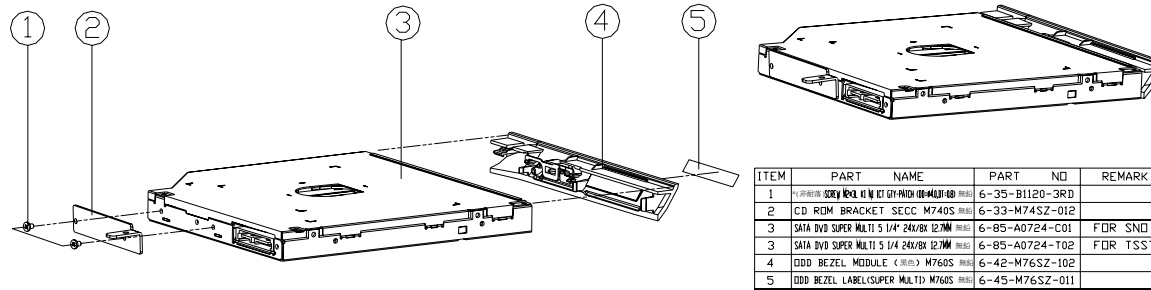

ITEM	PART NAME	PART NO	REMARK
1	ODD BEZEL MODULE (M760S) M760S	6-35-B1120-3RD	
2	CD ROM BRACKET SECC M740S M740S	6-33-M74SZ-012	
3	SATA DVD SUPER MULTI 5 1/4 24X/8X 12.7MM M760S	6-85-A0724-C01	FOR SNO
3	SATA DVD SUPER MULTI 5 1/4 24X/8X 12.7MM M760S	6-85-A0724-T02	FOR TSST
4	ODD BEZEL MODULE (M760S) M760S	6-42-M76SZ-102	
5	ODD BEZEL LABEL(SUPER MULTI) M760S	6-45-M76SZ-011	

Appendix B: Schematic Diagrams

This appendix has circuit diagrams of the *M740T/M740TU/M760T/M760TU* notebook's PCB's. The following table indicates where to find the appropriate schematic diagram.

Diagram - Page	Diagram - Page	Diagram - Page
<i>System Block Diagram - Page B - 2</i>	<i>VGA NB9M-4 - Page B - 19</i>	<i>5VS, 3VS, 3.3VM, 1.05VS, VIN1 - Page B - 36</i>
<i>Clock Generator - Page B - 3</i>	<i>VGA NB9M-5 - Page B - 20</i>	<i>Power 3.3V/5V - Page B - 37</i>
<i>Penryn (Socket-P) CPU 1/2 - Page B - 4</i>	<i>VGA NB9M-6 - Page B - 21</i>	<i>Power 1.5VS/1.05VS - Page B - 38</i>
<i>Penryn (Socket-P) CPU 2/2 - Page B - 5</i>	<i>VGA NB9M-7 - Page B - 22</i>	<i>Power 1.8V/0.9V - Page B - 39</i>
<i>CANTIGA 1/7, Host - Page B - 6</i>	<i>ICH9M 1/4, SATA - Page B - 23</i>	<i>Power GPU/NVVDD - Page B - 40</i>
<i>CANTIGA 2/7, Graphics - Page B - 7</i>	<i>ICH9M 2/4, PCI, USB - Page B - 24</i>	<i>AC-IN, Charger - Page B - 41</i>
<i>CANTIGA 3/7 - Page B - 8</i>	<i>ICH9M 3/4 - Page B - 25</i>	<i>VCORE - Page B - 42</i>
<i>CANTIGA 4/7 - Page B - 9</i>	<i>ICH9M 4/4 - Page B - 26</i>	<i>NVVDD - Page B - 43</i>
<i>CANTIGA 5/7 - Page B - 10</i>	<i>New Card, Mini PCIE - Page B - 27</i>	<i>HDMI - Page B - 44</i>
<i>CANTIGA 6/7 - Page B - 11</i>	<i>3G, Powergood - Page B - 28</i>	<i>External ODD Board for M76 - Page B - 45</i>
<i>CANTIGA 7/7 - Page B - 12</i>	<i>USB, Fan, TP, FP, Multi CON - Page B - 29</i>	<i>Click & Finger Board for M76 - Page B - 46</i>
<i>DDRII SO-DIMM - 0 - Page B - 13</i>	<i>Card Reader - Page B - 30</i>	<i>Multi Function Board - Page B - 47</i>
<i>DDRII SO-DIMM - 1 - Page B - 14</i>	<i>SATA ODD, LED, Hotkey, LID SW - Page B - 31</i>	<i>Audio Board - Page B - 48</i>
<i>Panel, Inverter, CRT - Page B - 15</i>	<i>PCI-E LAN RTL8111C - Page B - 32</i>	<i>Finger Sensor Board for M76 - Page B - 49</i>
<i>VGA NB9M-1 - Page B - 16</i>	<i>Audio Codec ALC662 - Page B - 33</i>	<i>Power Switch Board for M74 - Page B - 50</i>
<i>VGA NB9M-2 - Page B - 17</i>	<i>Audio AMP - Page B - 34</i>	<i>FingerPrint Board for M74 - Page B - 51</i>
<i>VGA NB9M-3 - Page B - 18</i>	<i>KBC-ITE IT8512E - Page B - 35</i>	<i>Power Switch Board for M76 - Page B - 52</i>

Table B - 1
Schematic Diagrams



Version Note

The schematic diagrams in this chapter are based upon version 6-7P-M74T9-004. If your mainboard (or other boards) are a later version, please check with the Service Center for updated diagrams (if required).

System Block Diagram

Sheet 1 of 51
System Block
Diagram

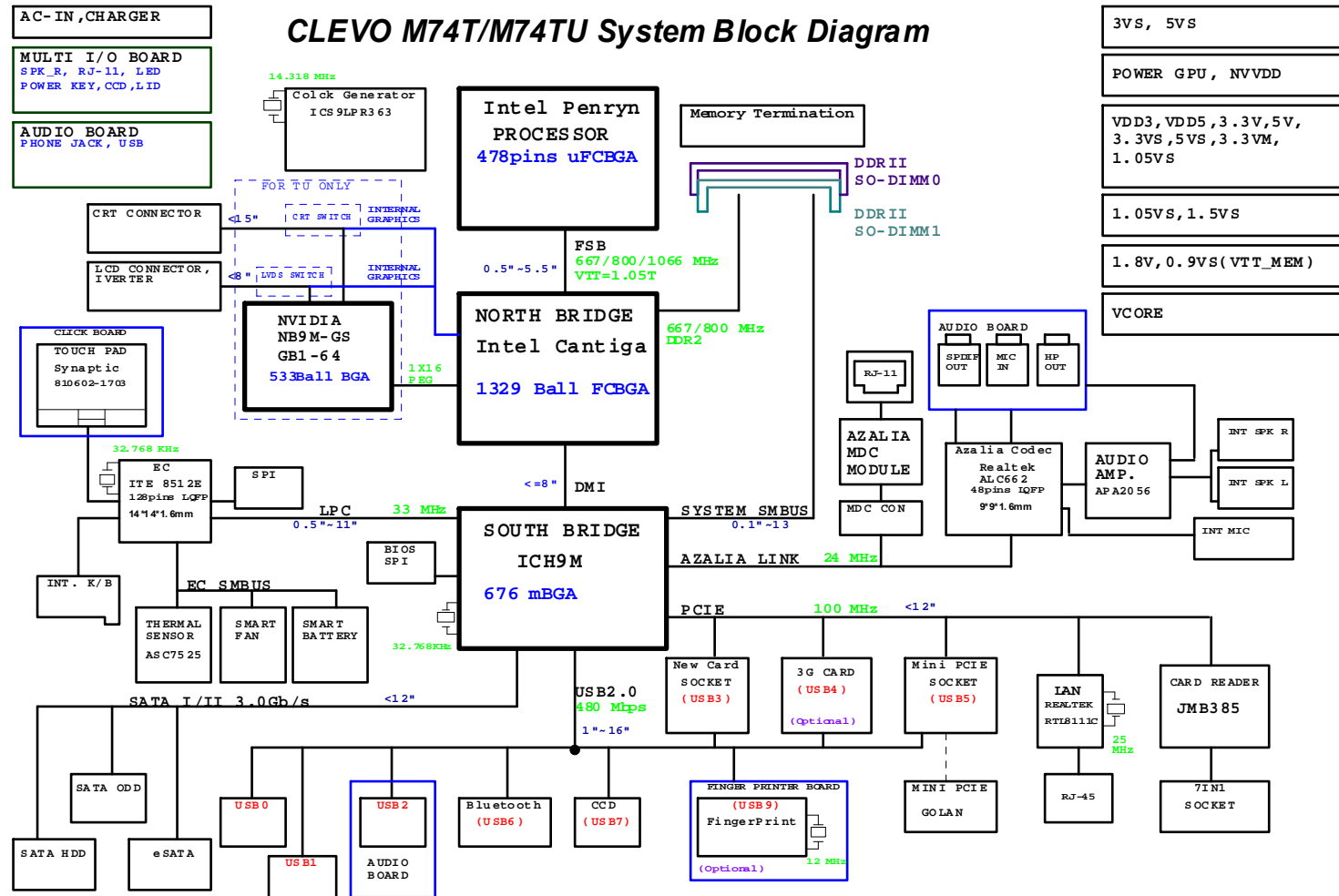

B - 2 System Block Diagram

Clock Generator

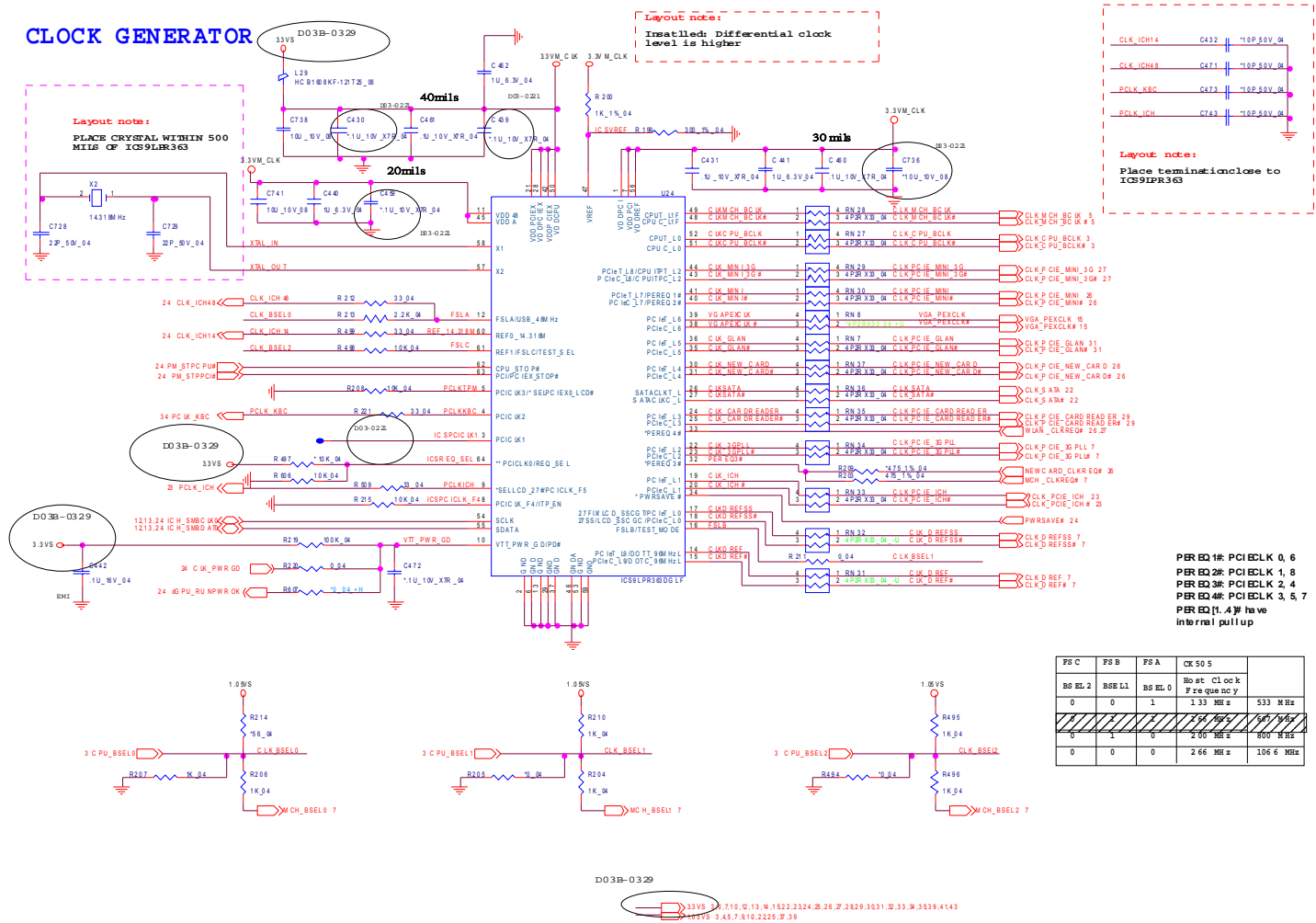

Sheet 2 of 51
Clock Generator

B.Schematic Diagrams

Penryn (Socket-P) CPU 2/2

B.Schematic Diagrams

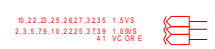
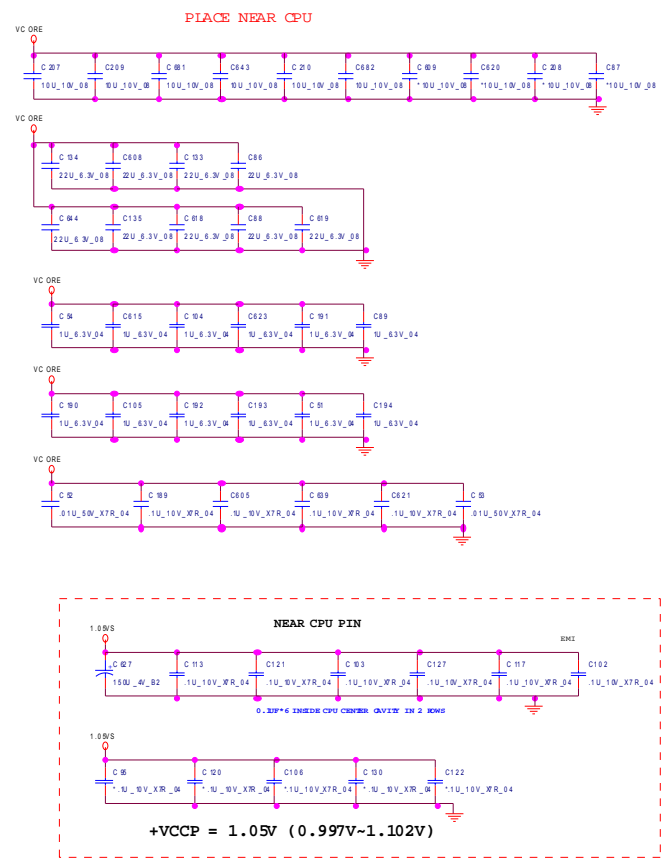
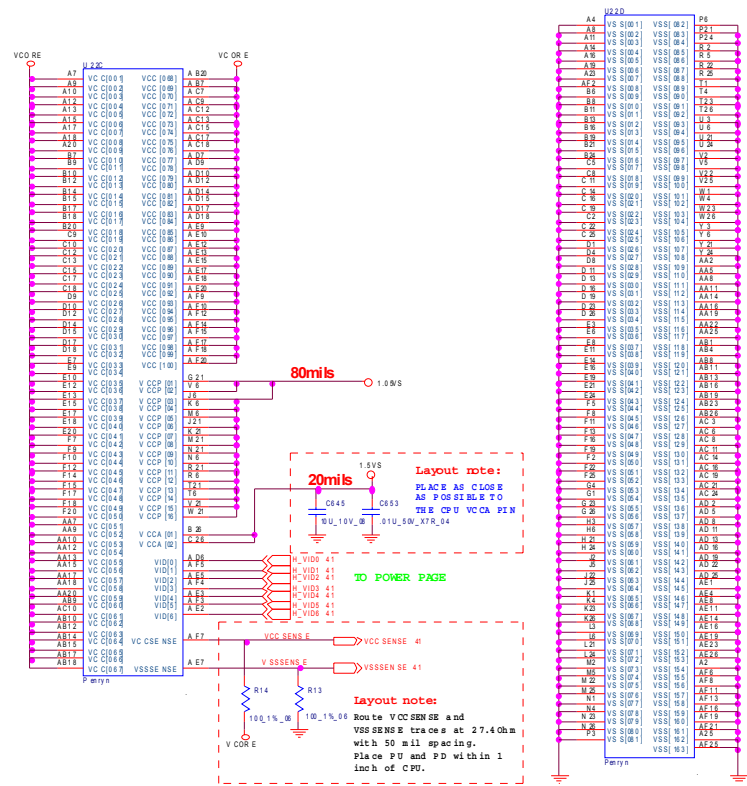

Sheet 4 of 51
Penryn (Socket-P)
CPU 2/2

CANTIGA 1/7, Host

Sheet 5 of 51
CANTIGA 1/7, Host

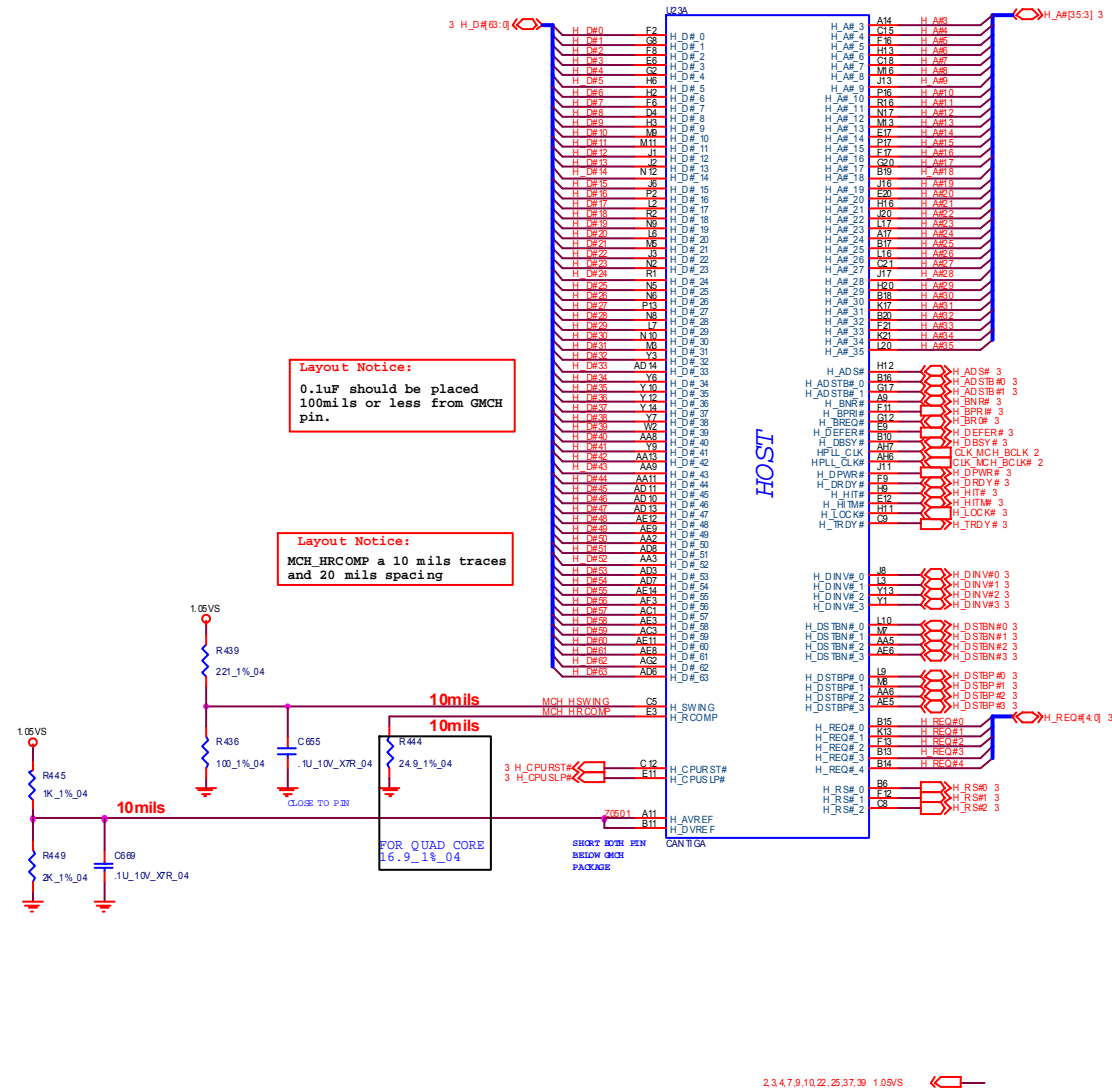

CANTIGA 2/7, Graphics

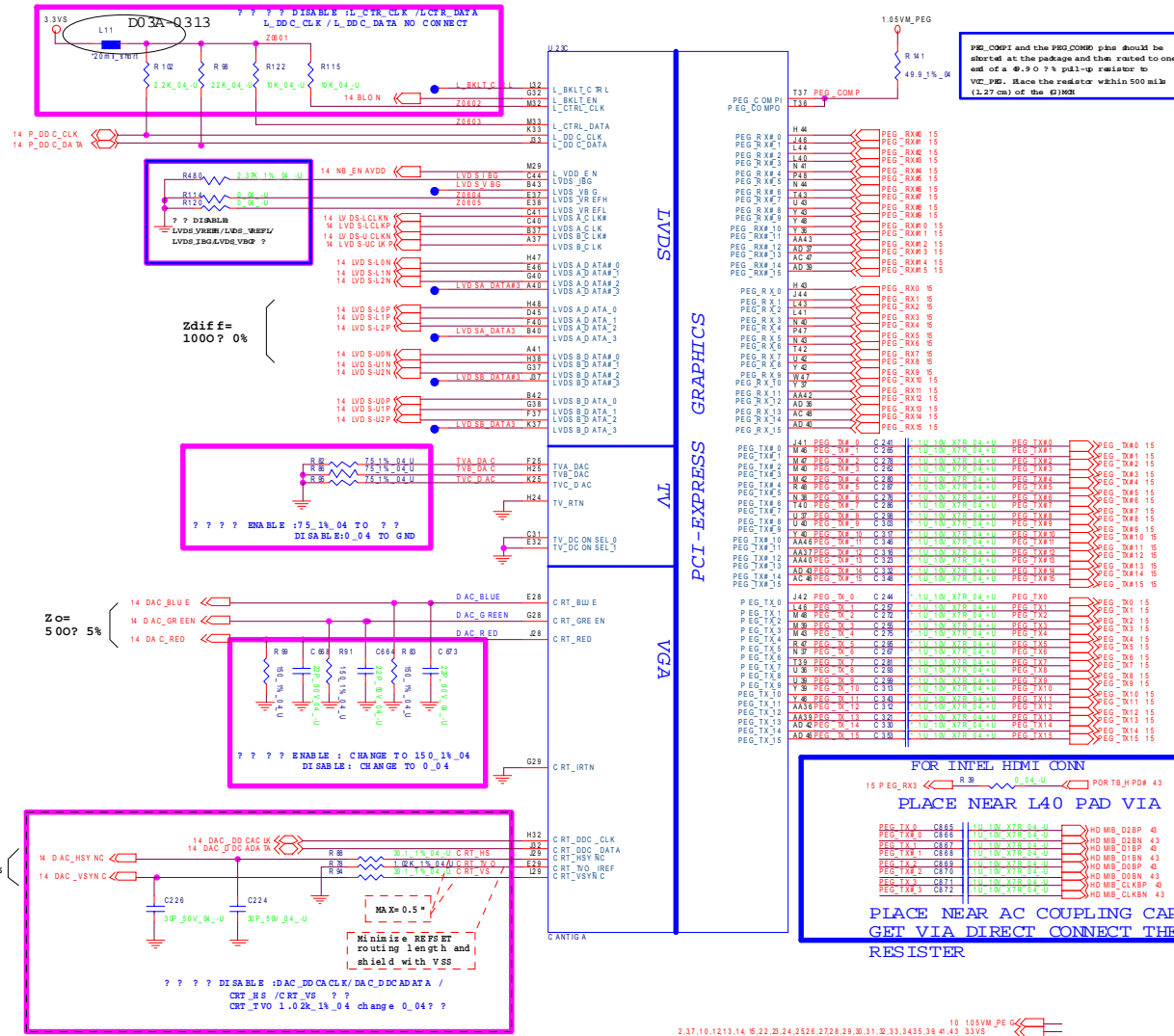

Sheet 6 of 51
CANTIGA 2/7,
Graphics

CANTIGA 3/7

Sheet 7 of 51
CANTIGA 3/7

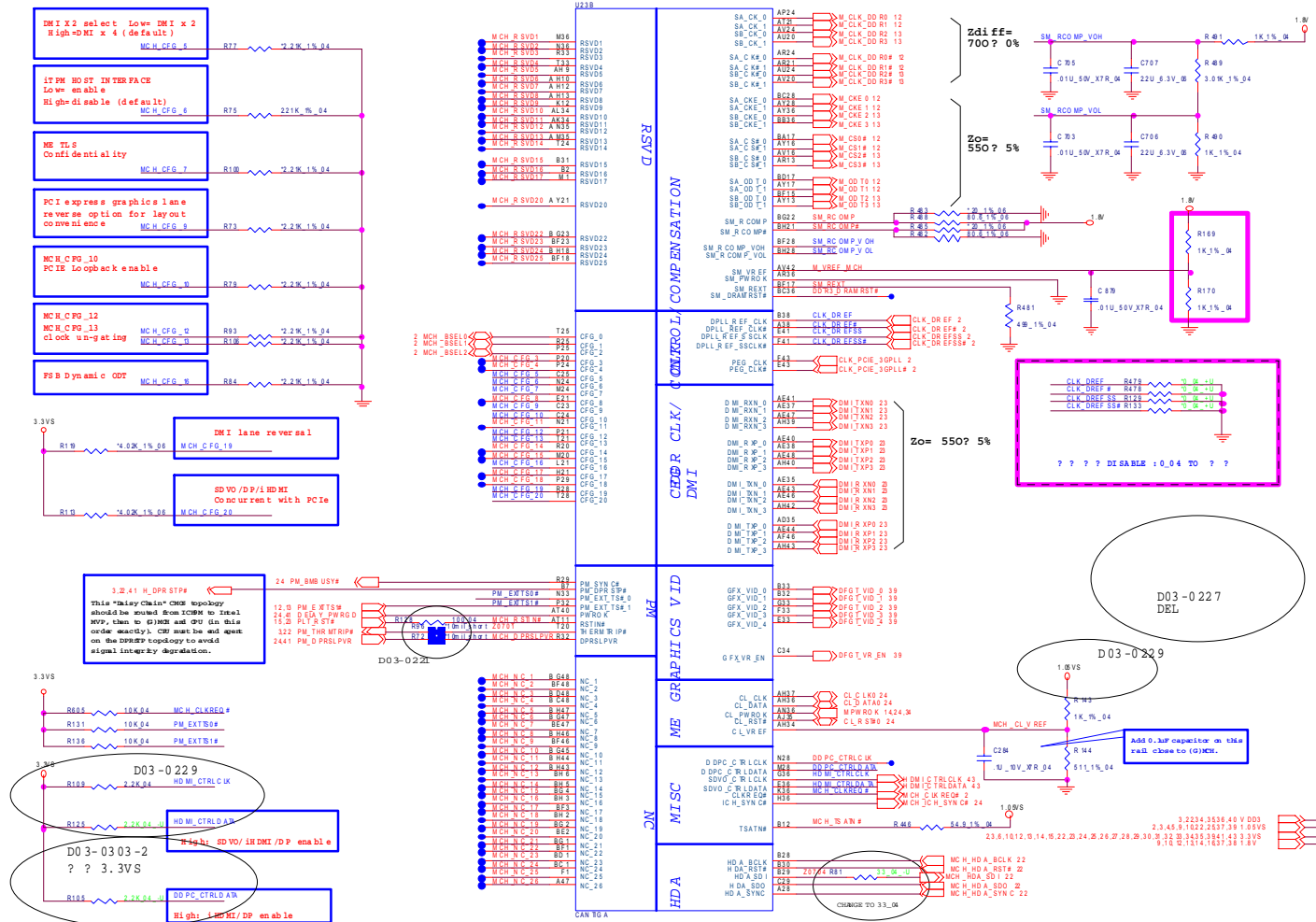

CANTIGA 4/7

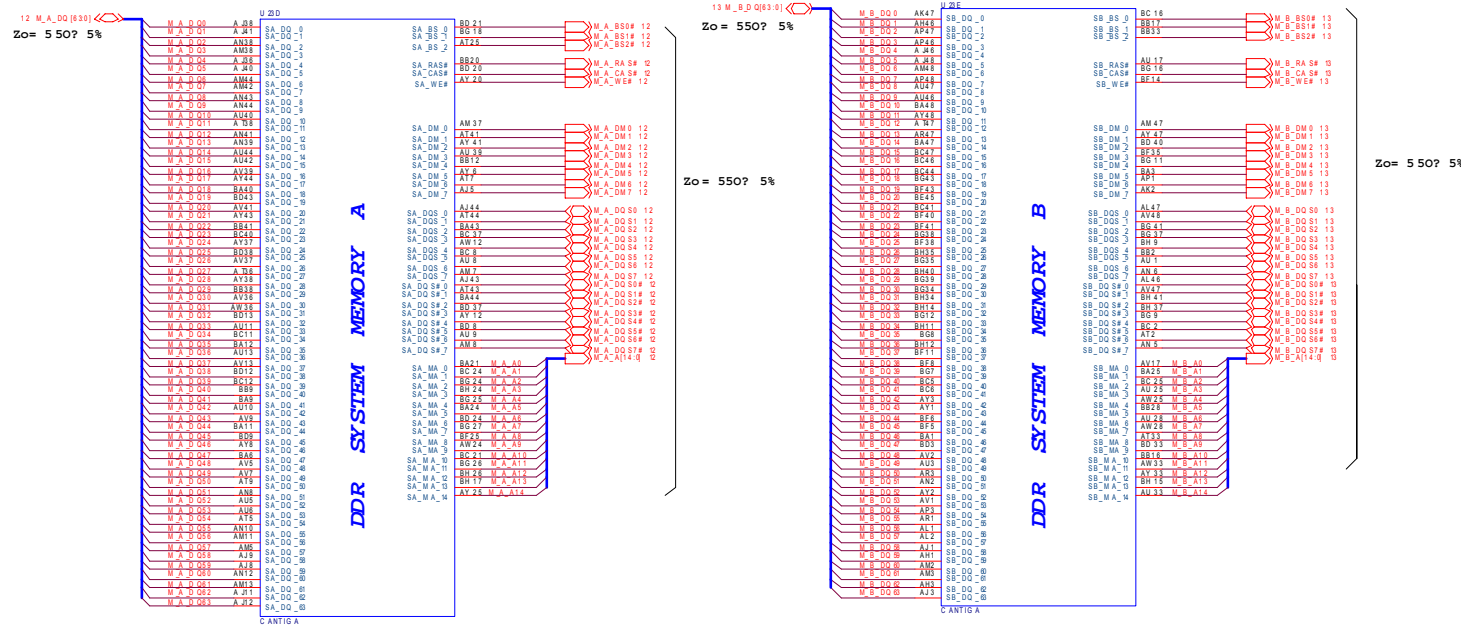

Sheet 8 of 51
CANTIGA 4/7

B. Schematic Diagrams

CANTIGA 5/7

Sheet 9 of 51
CANTIGA 5/7

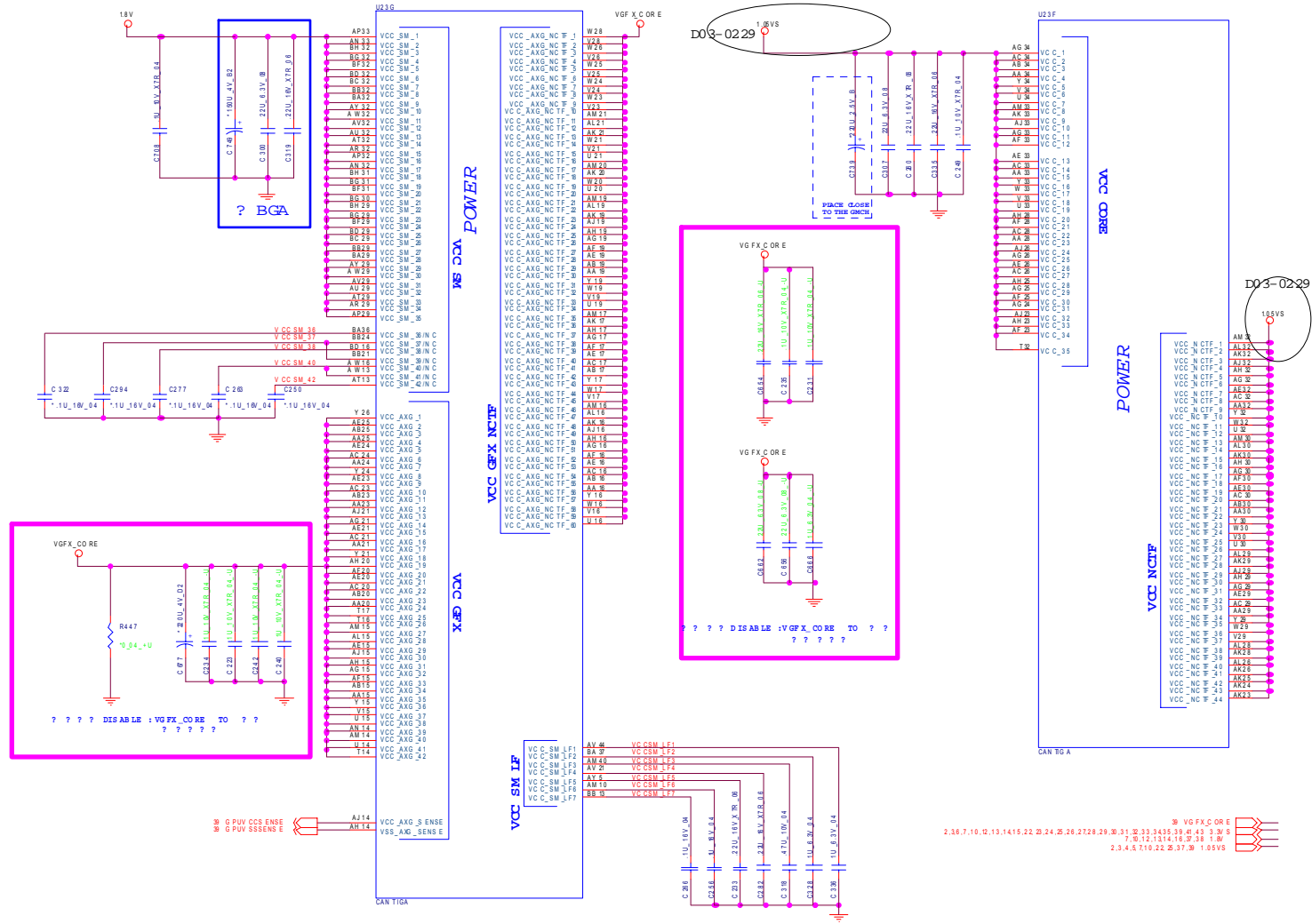

CANTIGA 6/7

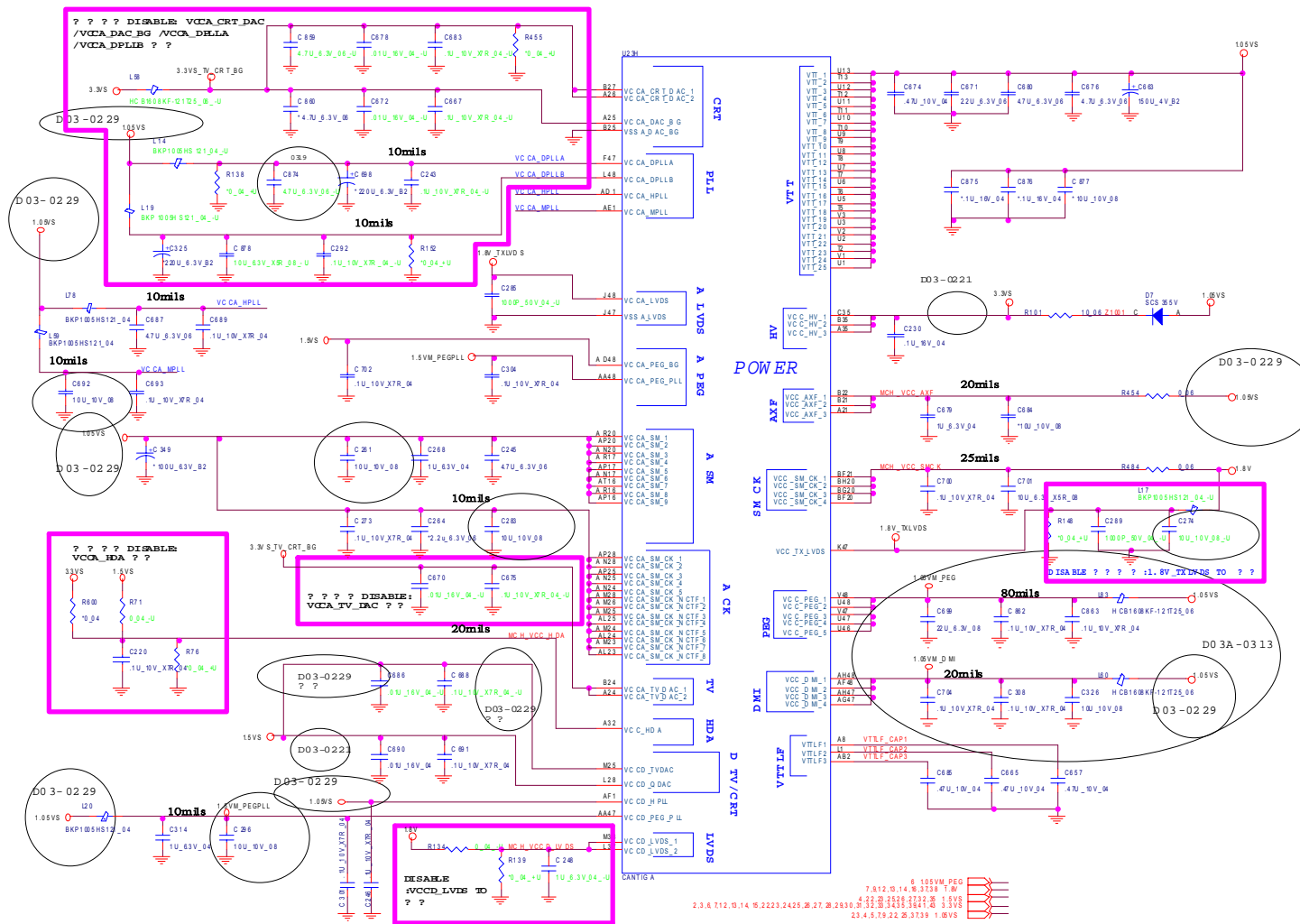
Sheet 10 of 51
CANTIGA 6/7

CANTIGA 7/7

Sheet 11 of 51
CANTIGA 7/7

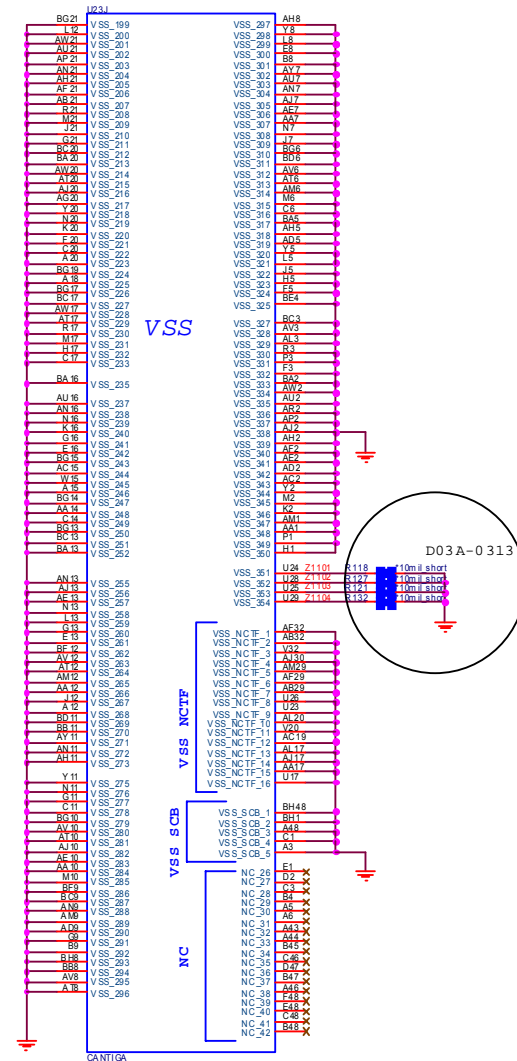
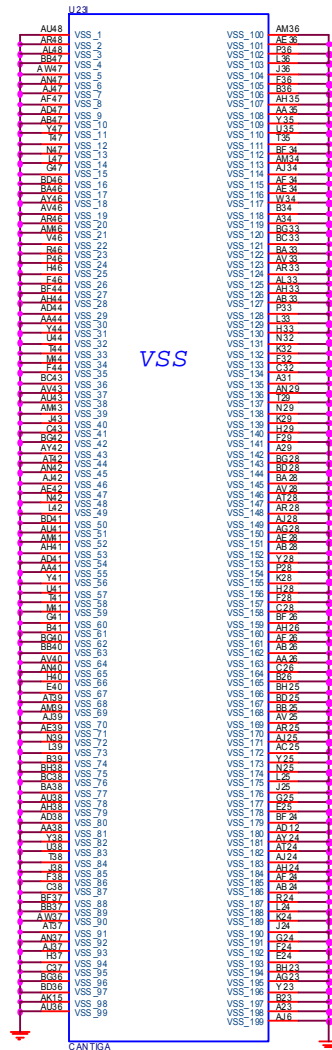

DDRII SO-DIMM - 1

SO-DIMM 1

Sheet 13 of 51
DDRII SO-DIMM - 1

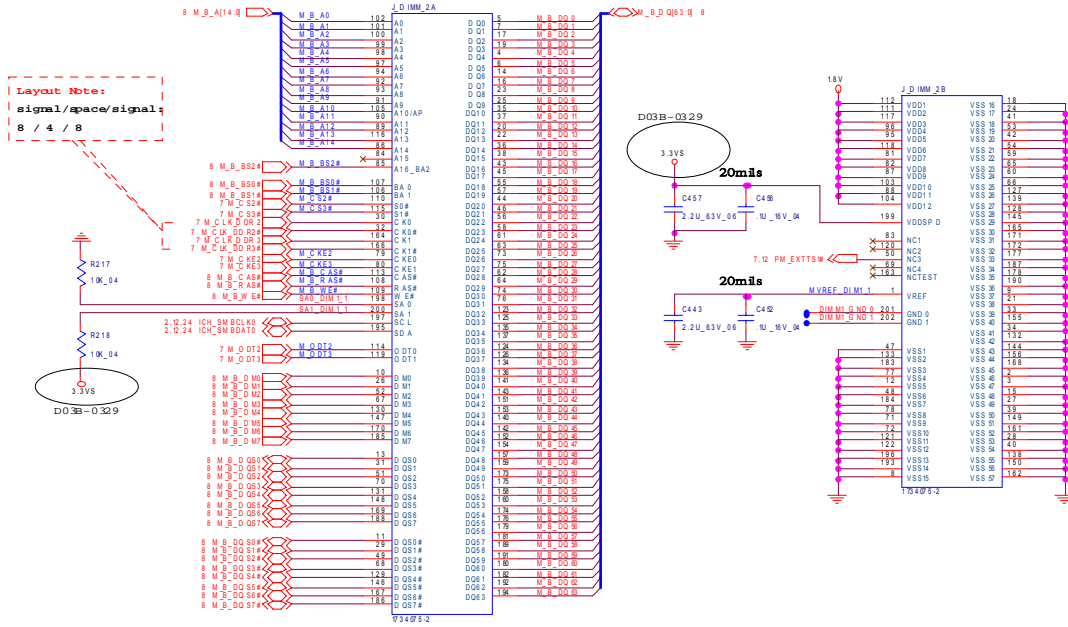

Layout note:
SO-DIMM_1 is placed farther from
the GMCH than SO-DIMM_0

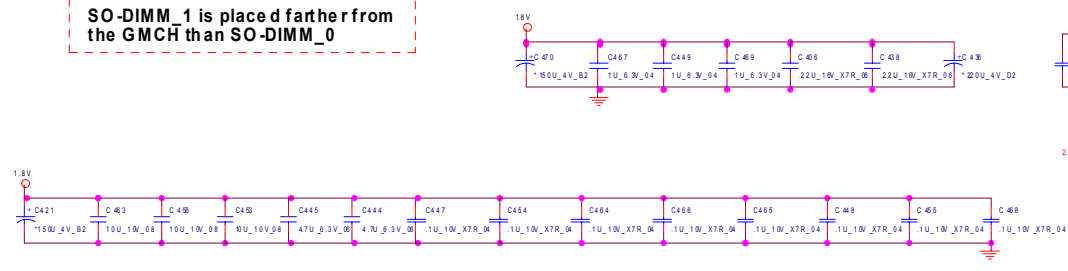
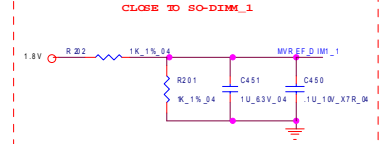
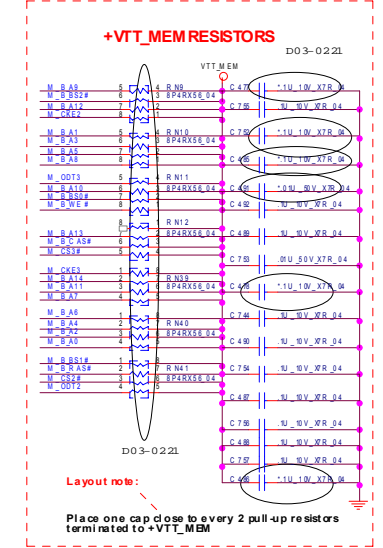

Panel, Inverter, CRT

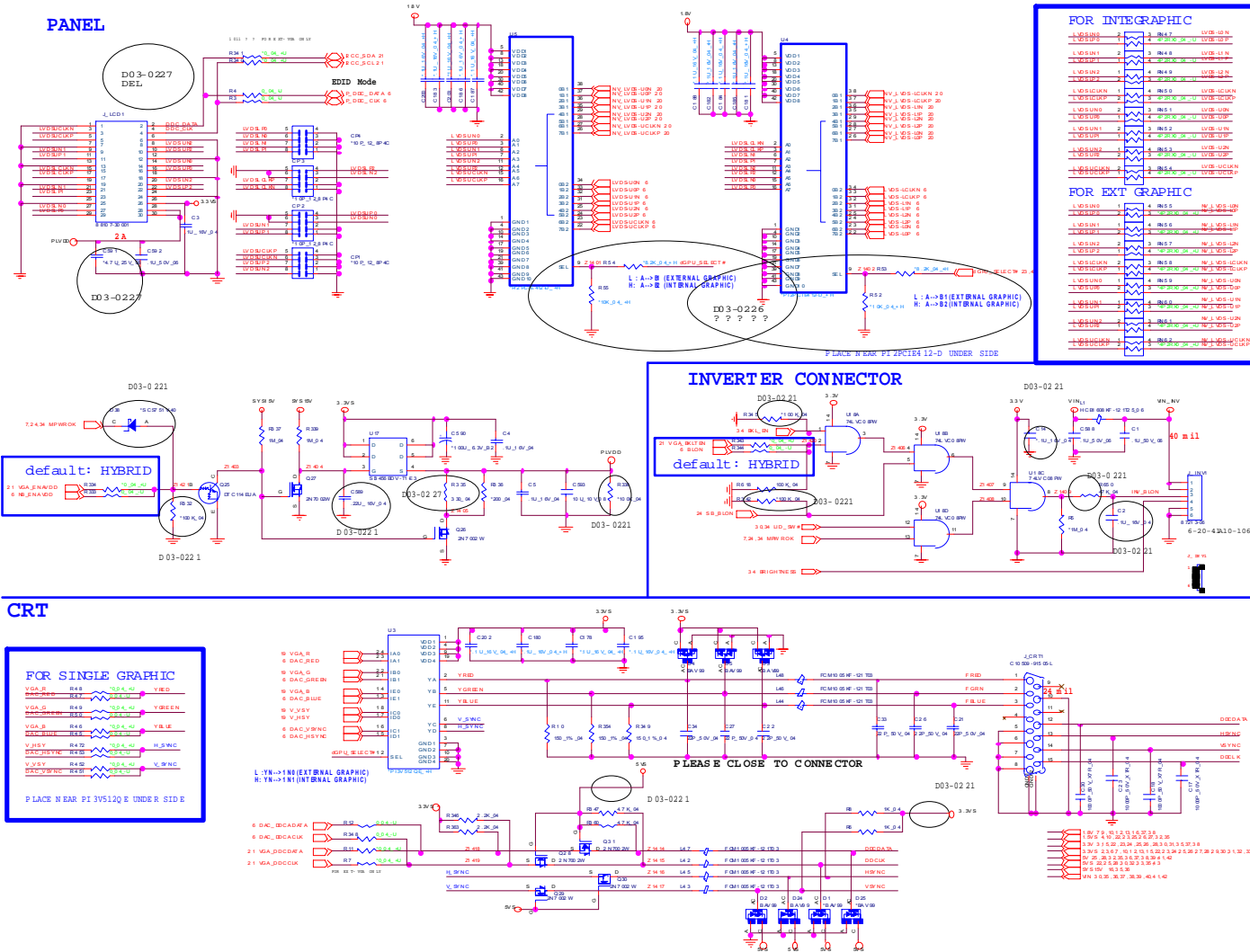

Sheet 14 of 51
Panel, Inverter,
CRT

B.Schematic Diagrams

VGA NB9M-1

Sheet 15 of 51
VGA NB9M-1

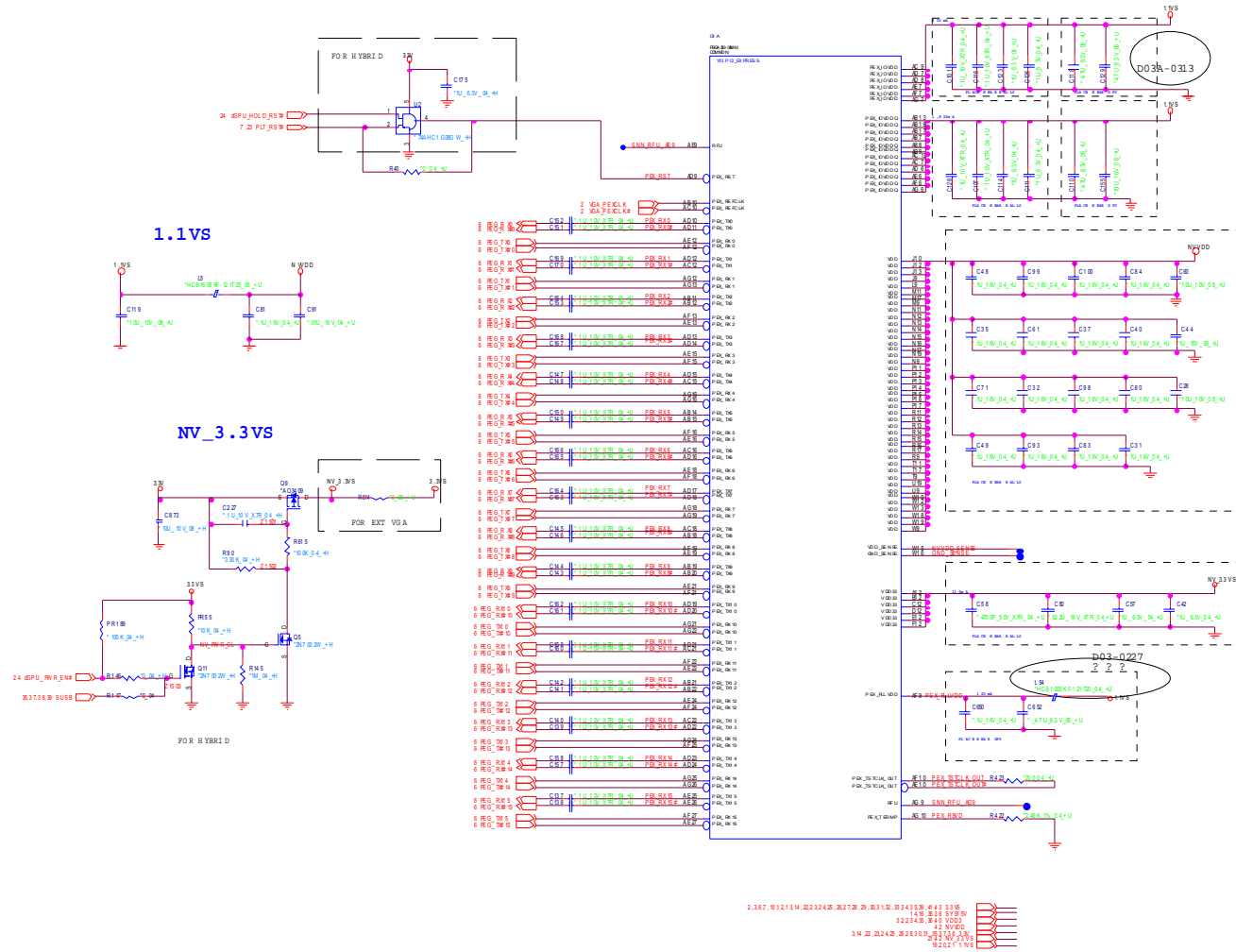

VGA NB9M-2

B.Schematic Diagrams

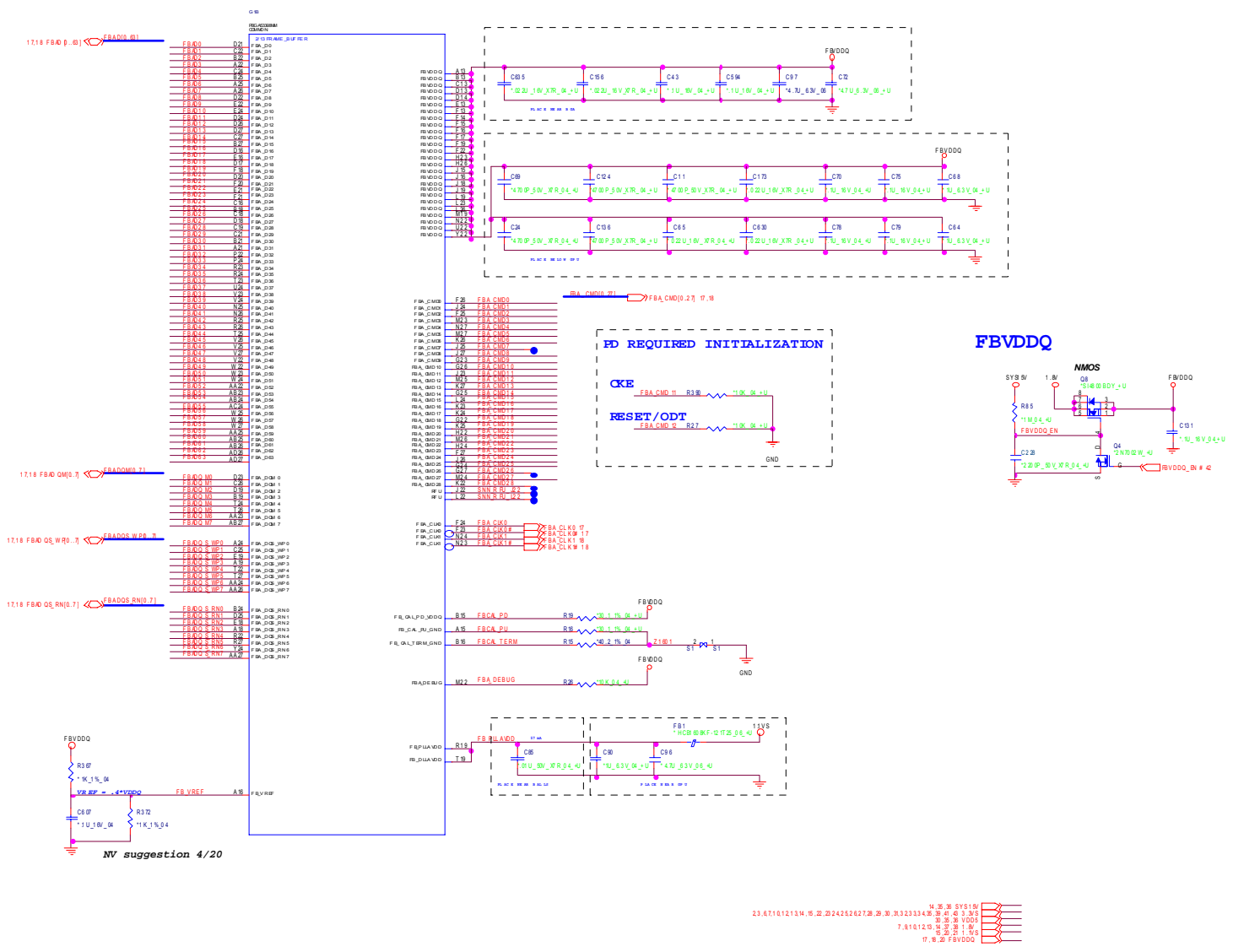

Sheet 16 of 51
VGA NB9M-2

4.36.36 SYS10
0.36.36 VDD0
0.36.36 VDD1
7.81012.0.0.2.1.VG
0.36.36 FBVDDQ

VGA NB9M-3

Sheet 17 of 51
VGA NB9M-3

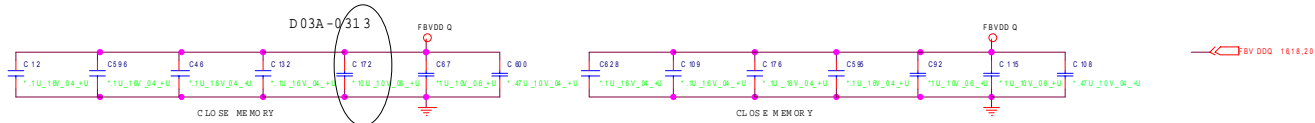
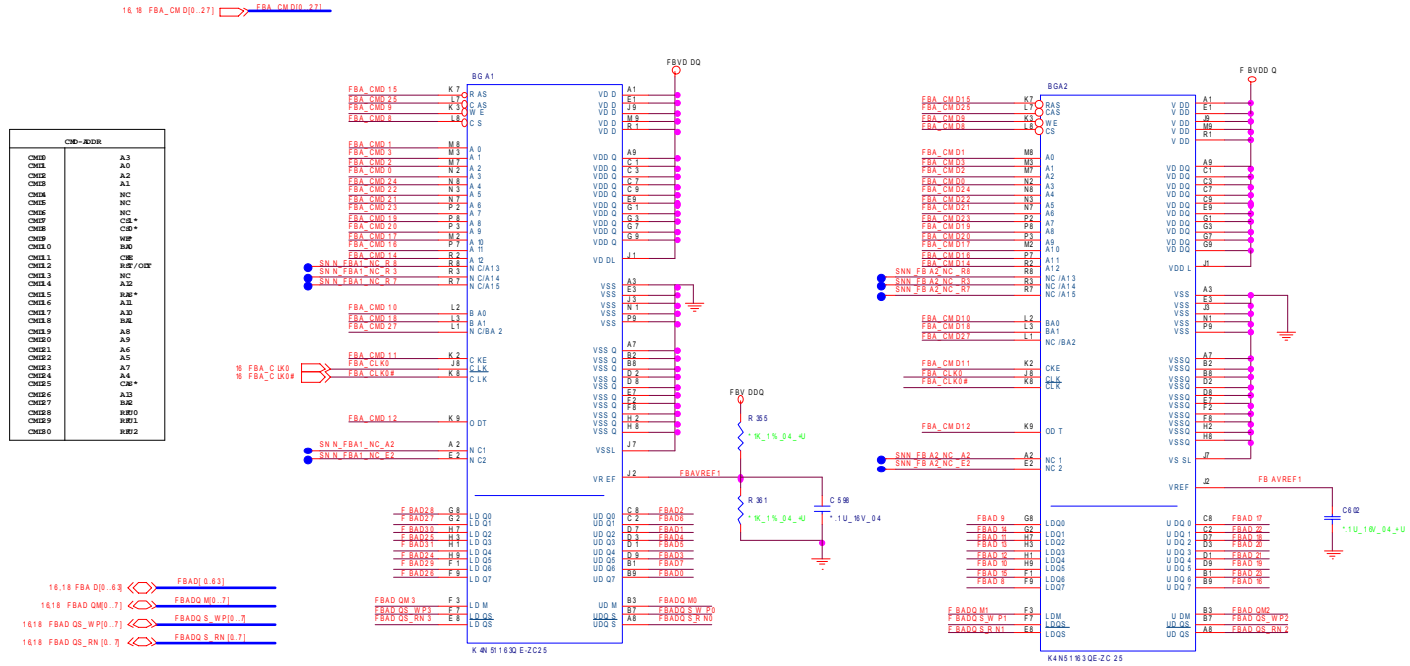

VGA NB9M-4

CMD	NC
CM0	NC
CM1	NC
CM2	NC
CM3	A1
CM4	A3
CM5	A4
CM6	A5
CM7	CS1*
CM8	CS0*
CM9	WE*
CM10	RA0
CM11	CS2*
CM12	RST_C0D7
CM13	A2
CM14	A12
CM15	RA0*
CM16	A13
CM17	A10
CM18	BA3
CM19	A8
CM20	A9
CM21	A6
CM22	NC
CM23	A7
CM24	NC
CM25	CS0*
CM26	AL3
CM27	BA2
CM28	RF00
CM29	RFU1
CM30	RFU2

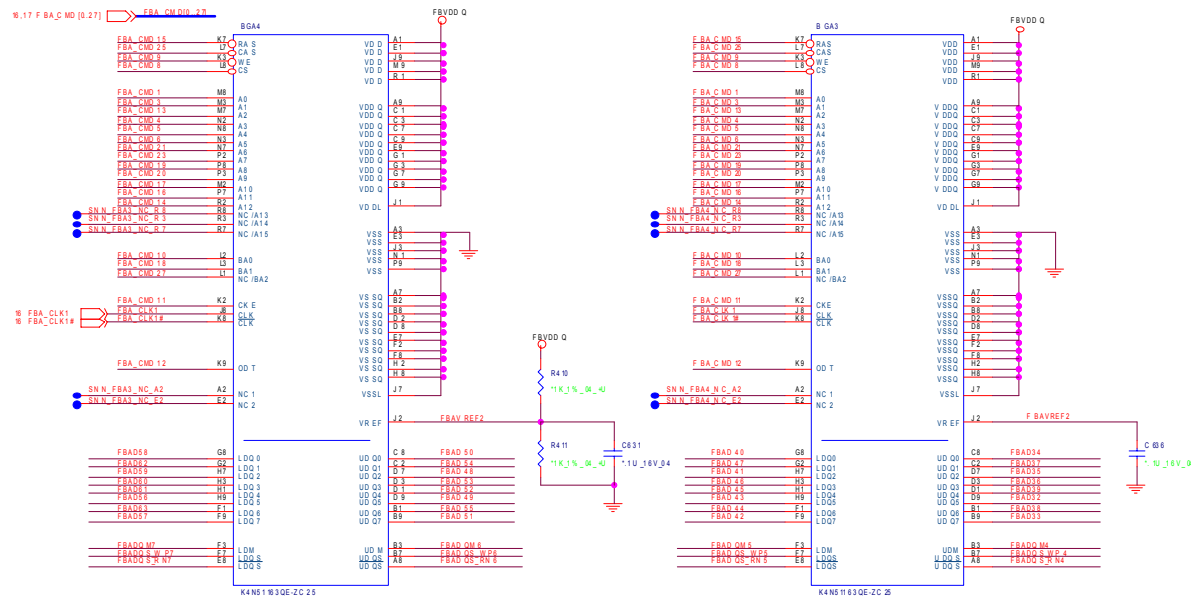

Sheet 18 of 51
VGA NB9M-4

B. Schematic Diagrams

- 14 17 FBAD0_031 <-> FBAD0_031
- 16 17 FBAD0_M0_7 <-> FBAD0_M0_7
- 16 17 FBAD0_S_W_P10_71 <-> FBAD0_S_W_P10_71
- 16 17 FBAD0_S_R_N10_71 <-> FBAD0_S_R_N10_71

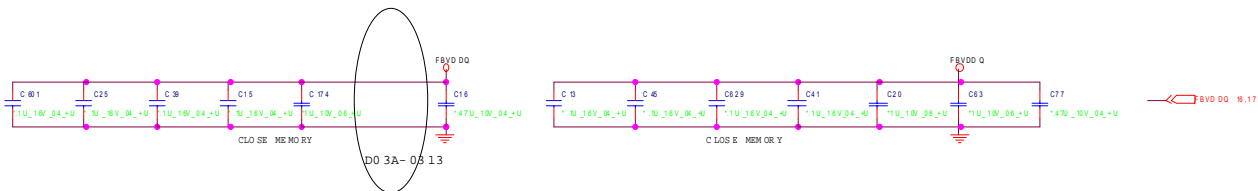

VGA NB9M-5

Sheet 19 of 51
VGA NB9M-5

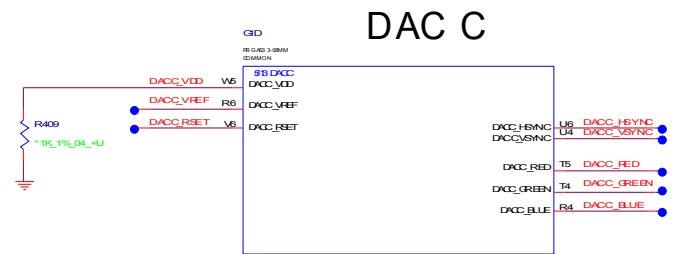
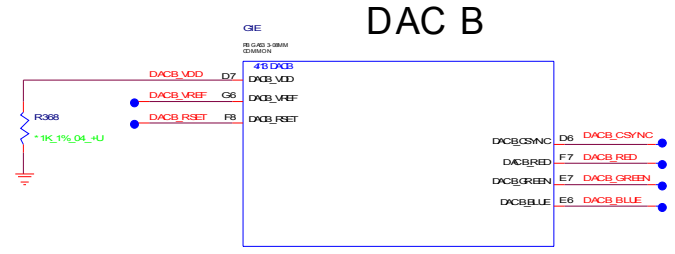
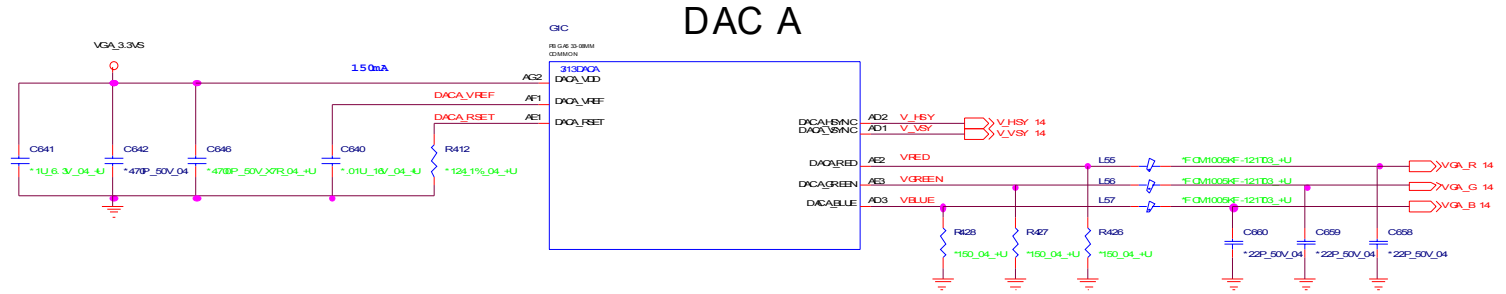

21 VGA_3.3V5

VGA NB9M-6

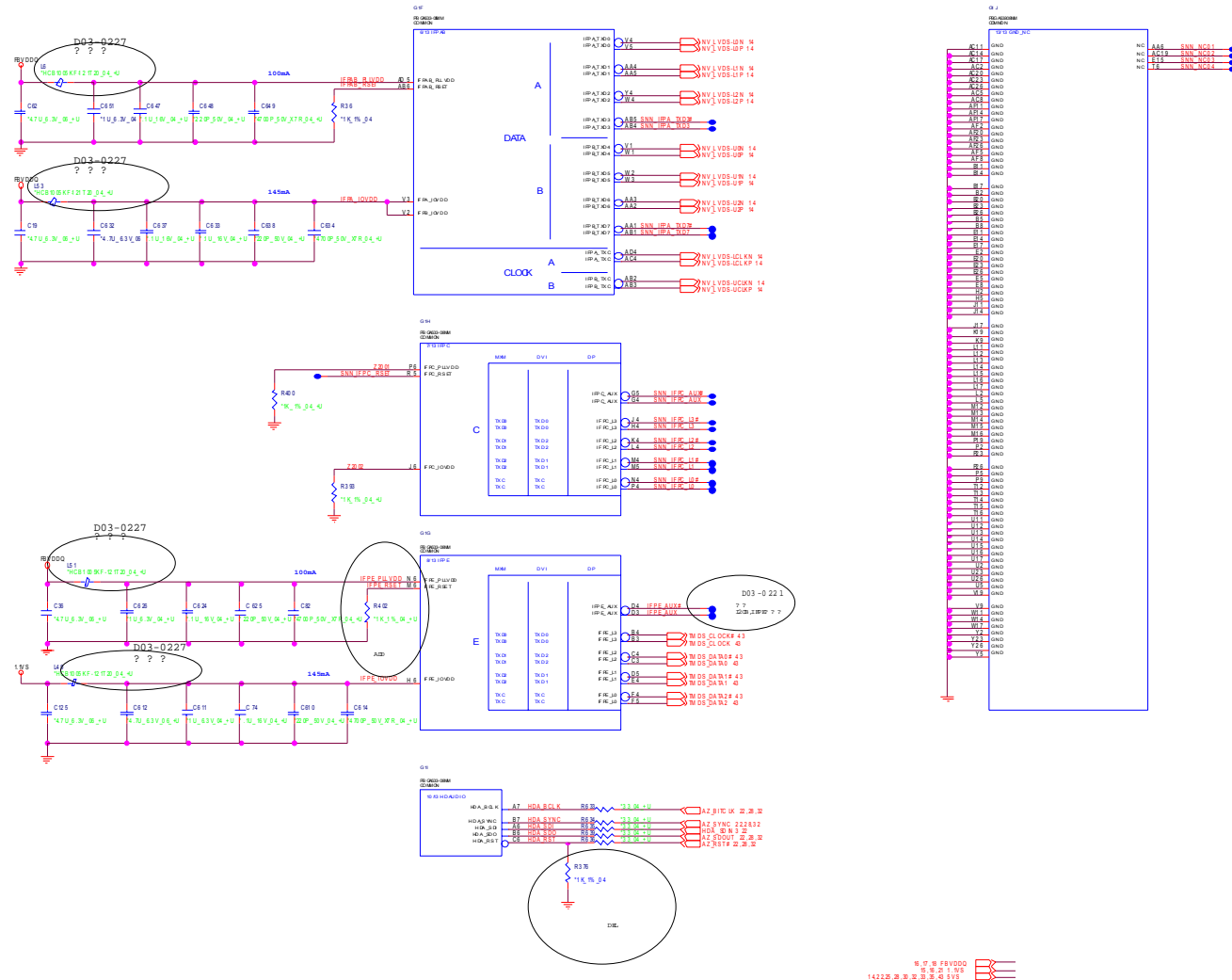

Sheet 20 of 51
VGA NB9M-6

VGA NB9M-7

Sheet 21 of 51
VGA NB9M-7

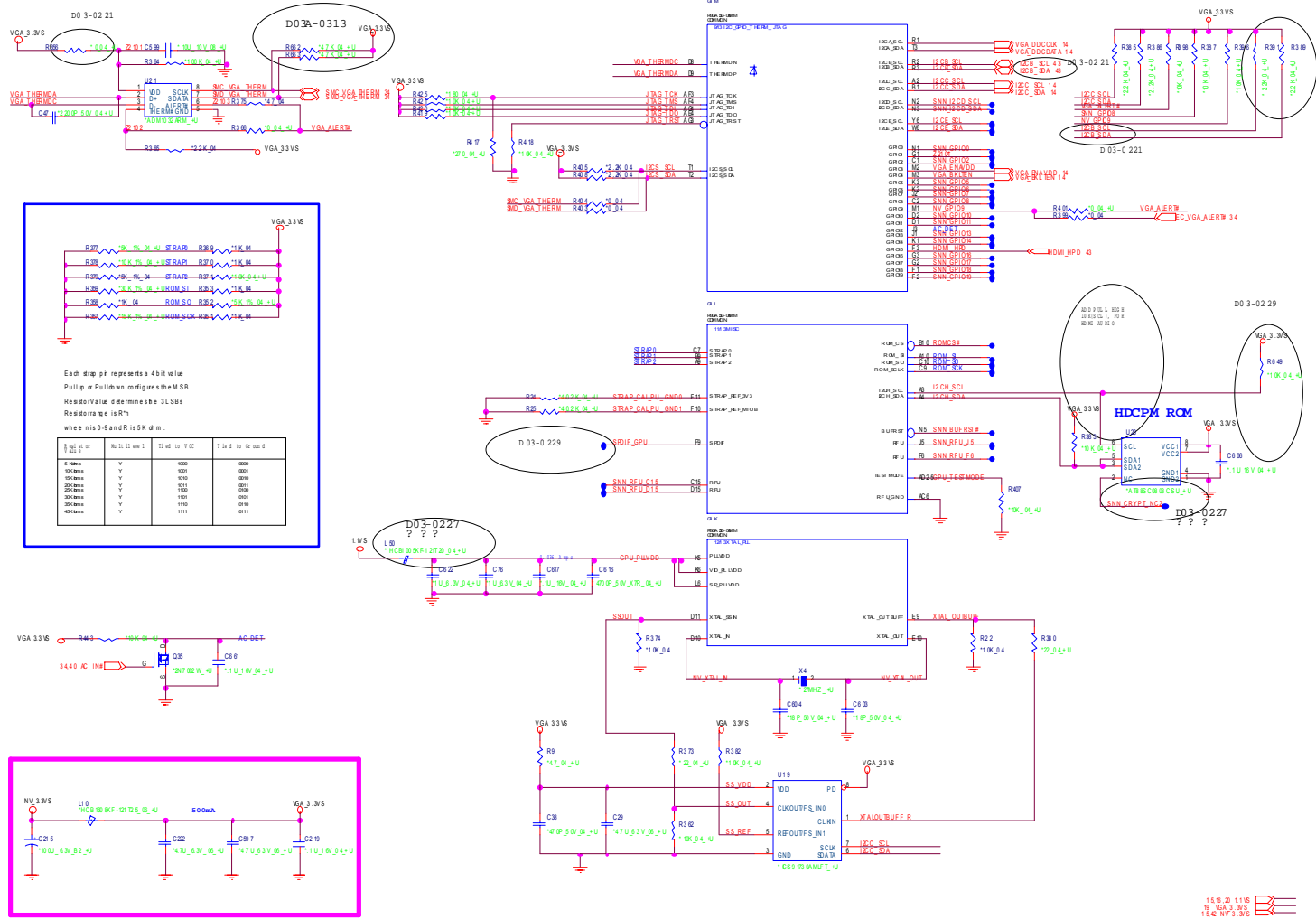

ICH9M 1/4, SATA

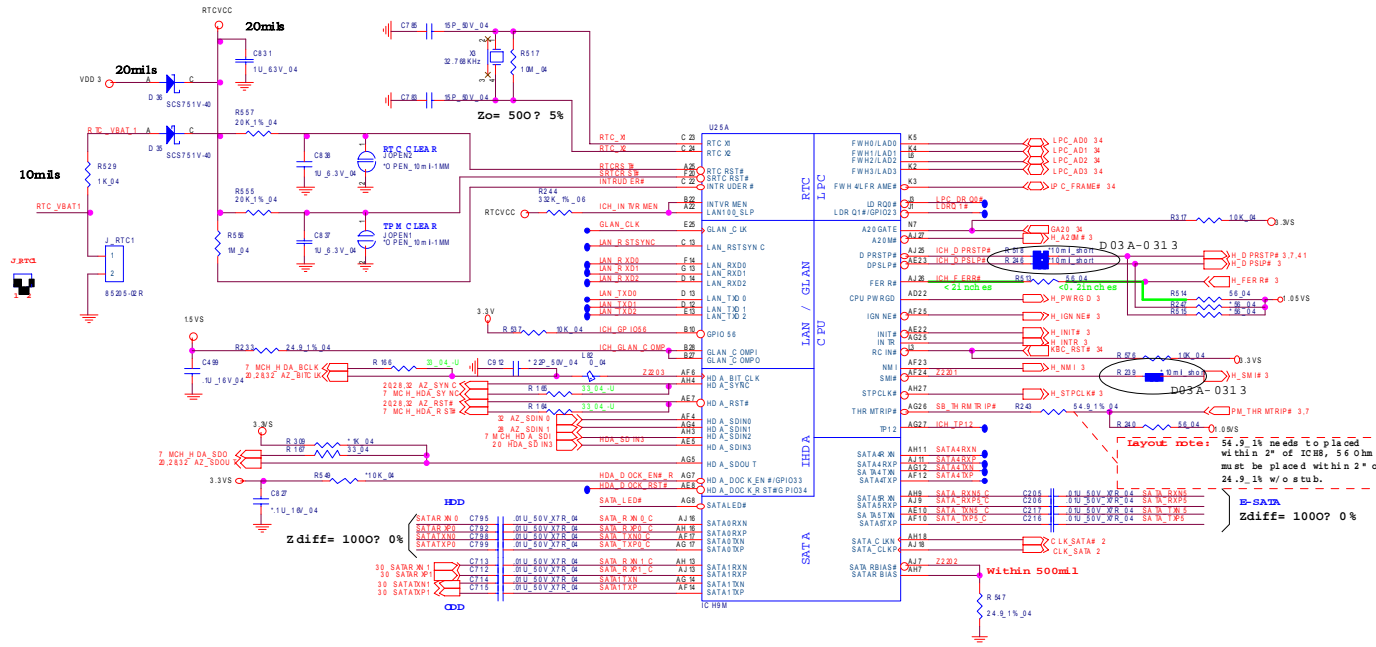

Sheet 22 of 51
ICH9M 1/4, SATA

B. Schematic Diagrams

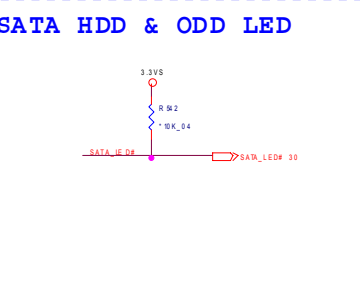
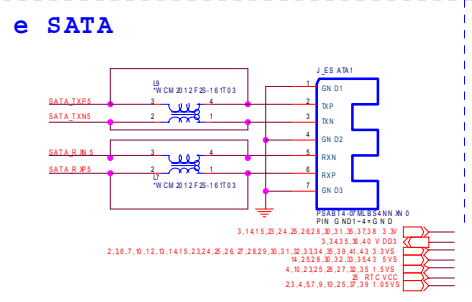
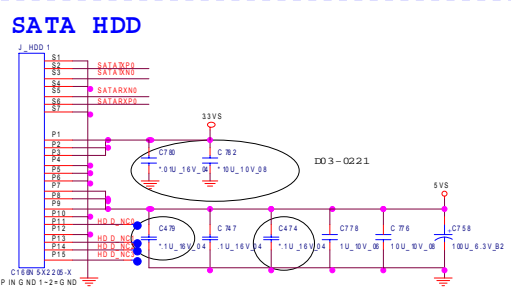

Schematic Diagrams

ICH9M 2/4, PCI, USB

B.Schematic Diagrams

Sheet 23 of 51
ICH9M 2/4,
PCI, USB

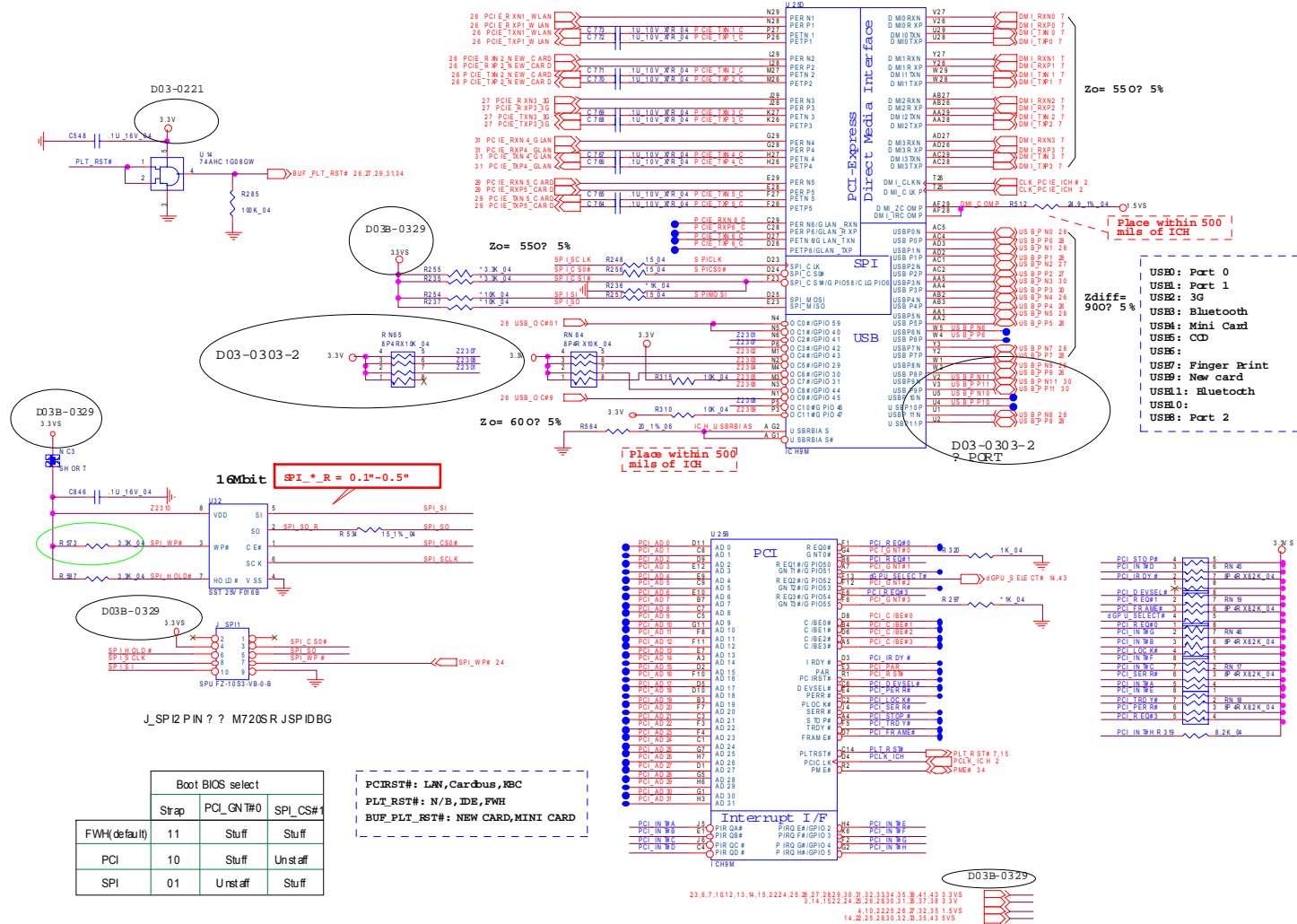

ICH9M 3/4

B.Schematic Diagrams

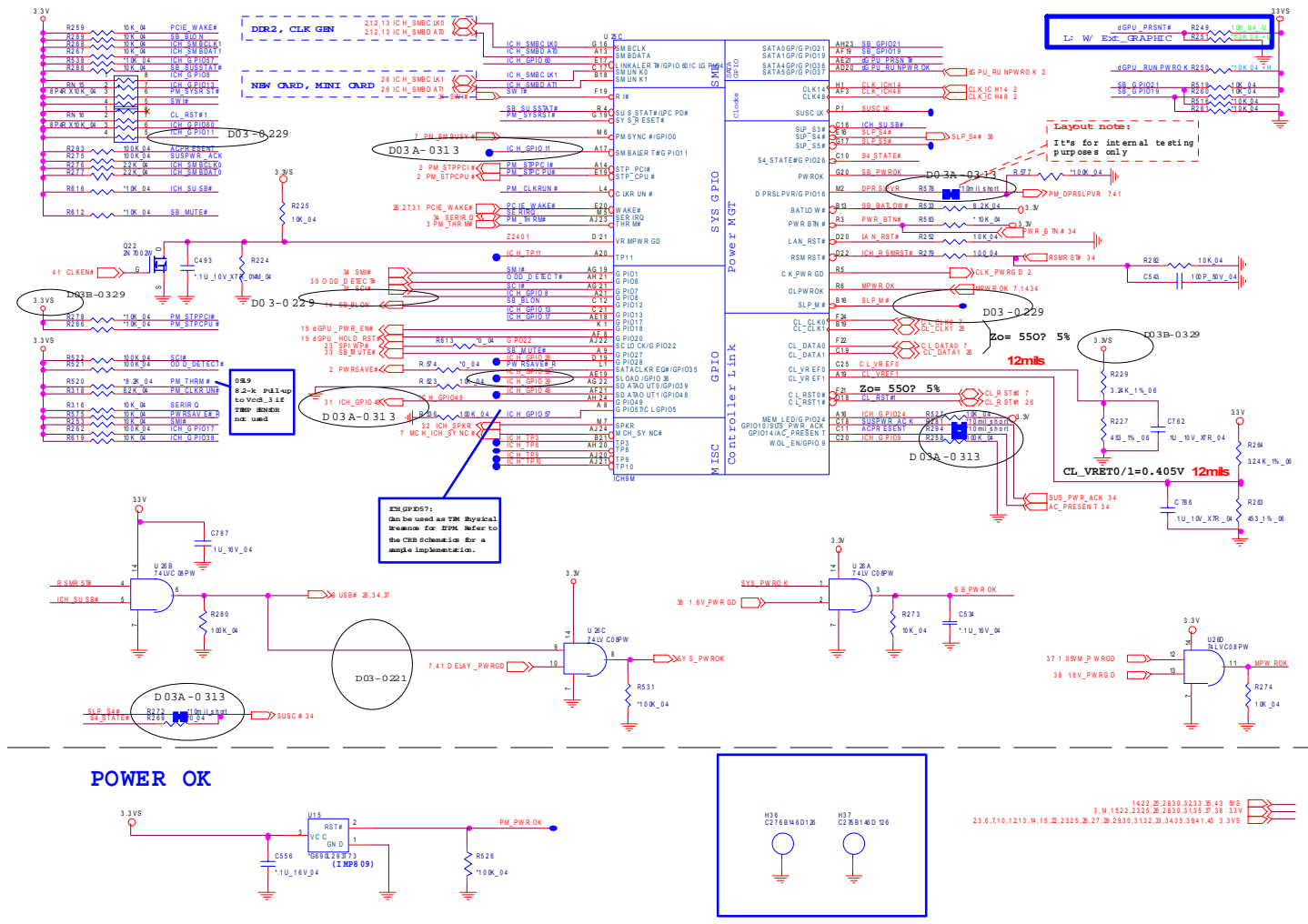

Sheet 24 of 51
ICH9M 3/4

Schematic Diagrams

ICH9M 4/4

Sheet 25 of 51
ICH9M 4/4

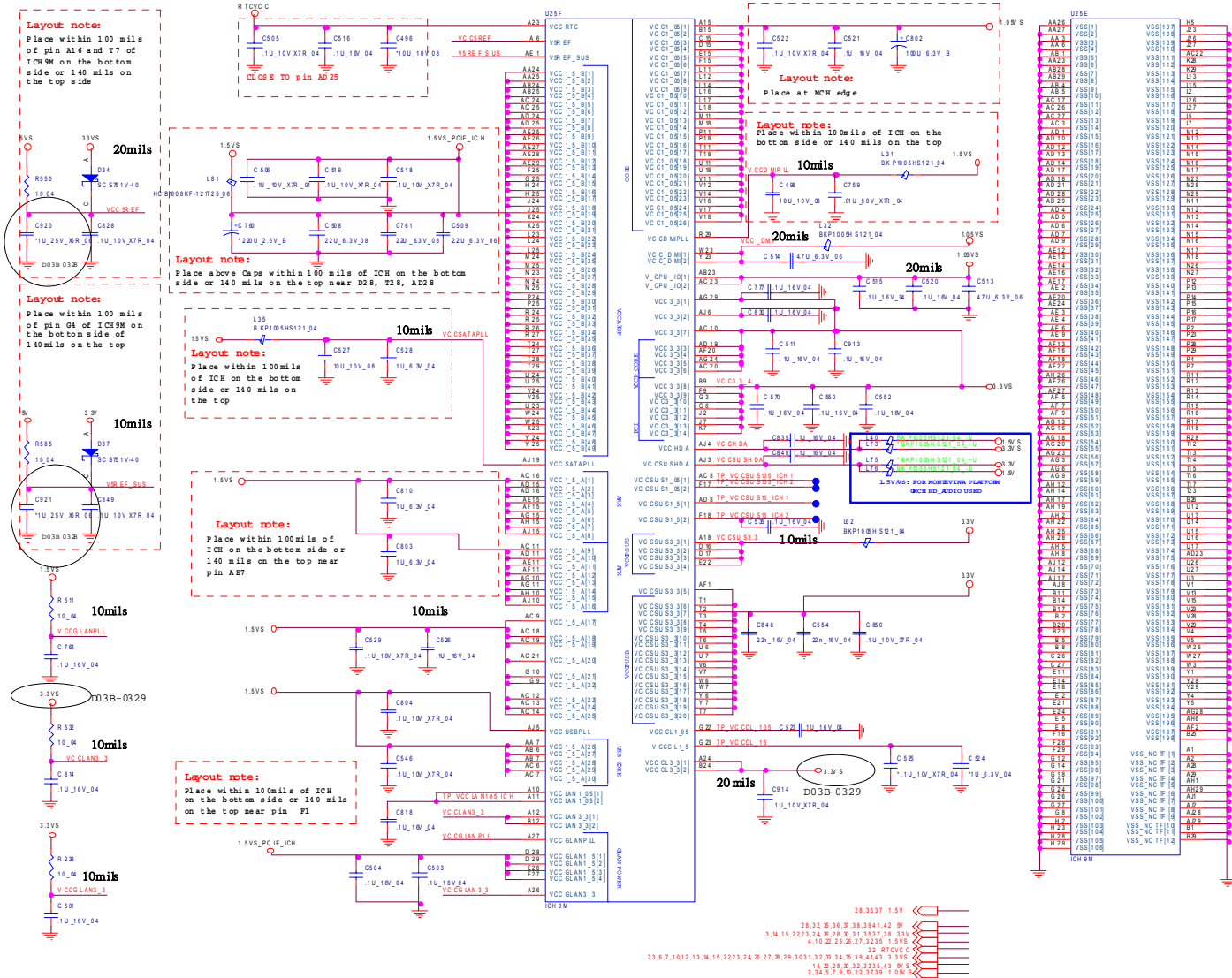

New Card, Mini PCIE

NEW CARD

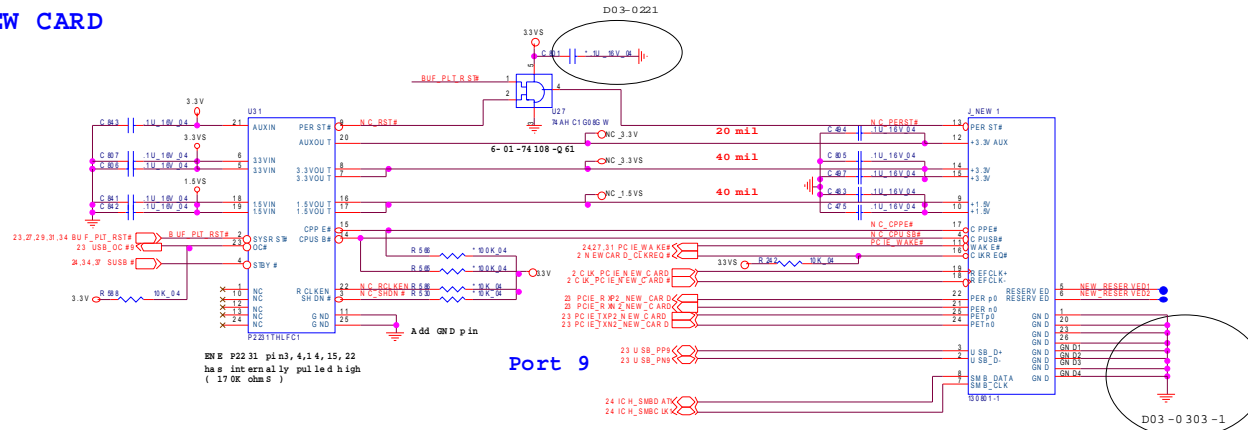

Sheet 26 of 51
New Card,
Mini PCIE

MINI CARD

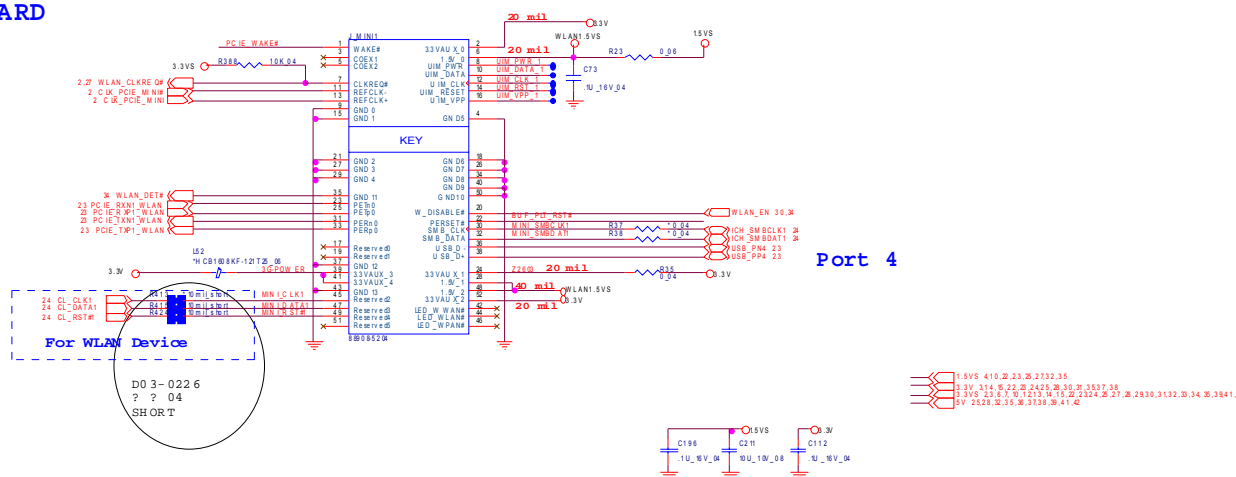

B. Schematic Diagrams

3G, Powergood

3G

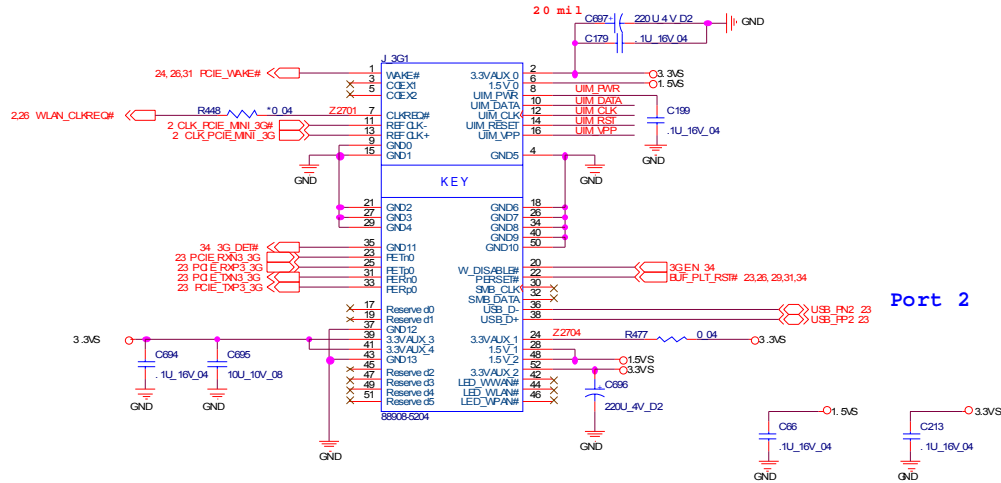

Port 2

SIM CONN

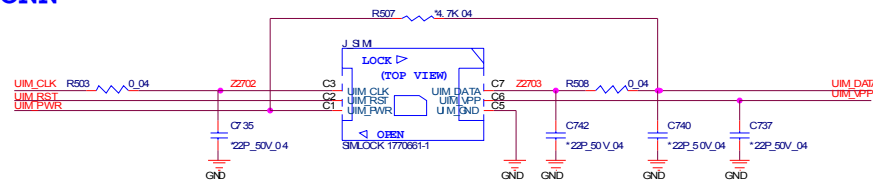

- 1.5V/5 4, 10, 22, 23, 25, 26, 32, 36
- 3.3V 3, 14, 15, 22, 23, 24, 25, 26, 28, 30, 31, 35, 37, 38
- 3.3V/5 2, 3, 6, 7, 10, 12, 13, 14, 15, 22, 23, 24, 25, 26, 28, 29, 30, 31, 32, 33, 34, 35, 39, 41, 43
- 5V 14, 22, 25, 28, 30, 32, 33, 35, 43

Sheet 27 of 51
3G, Powergood

USB, Fan, TP, FP, Multi CON

USB PORT*2

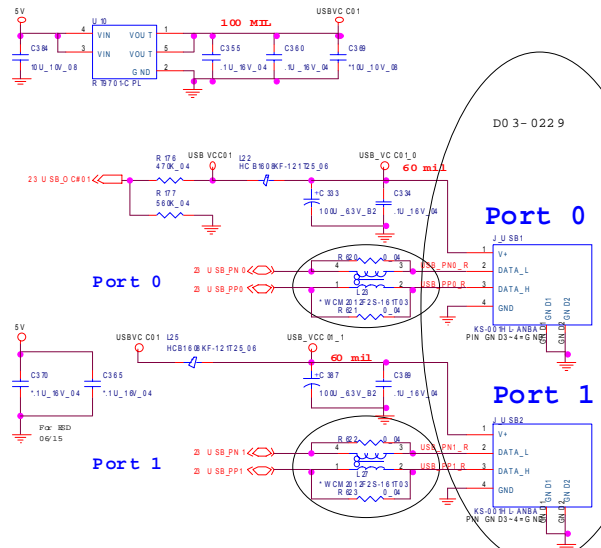

FAN CONTROL

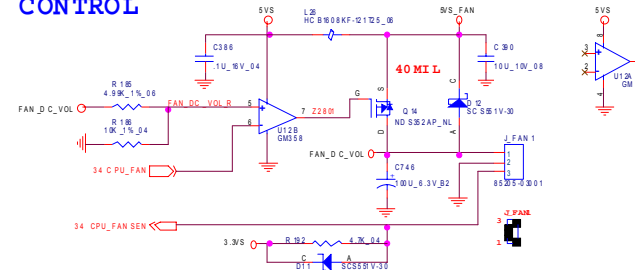

CLICK CONN FOR M760T

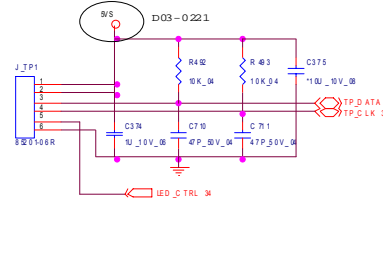

FP CONN

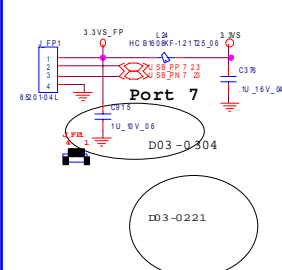

MULTI I/O CONN

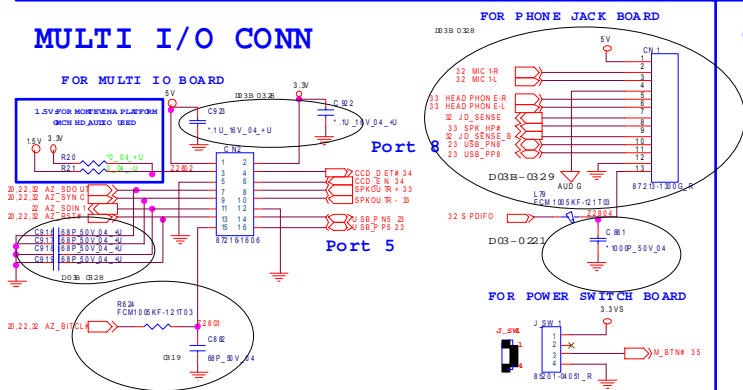

CLICK CONN FOR M740T

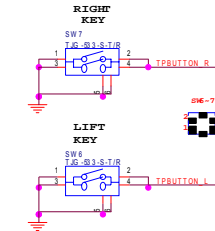
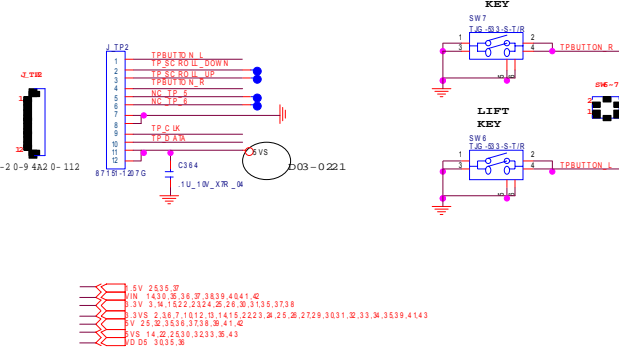

Sheet 28 of 51
USB, Fan, TP, FP,
Multi CON

B.Schematic Diagrams

Card Reader

Sheet 29 of 51
Card Reader

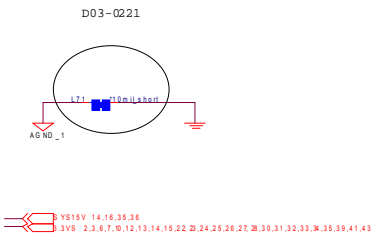
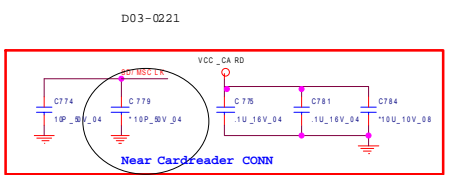
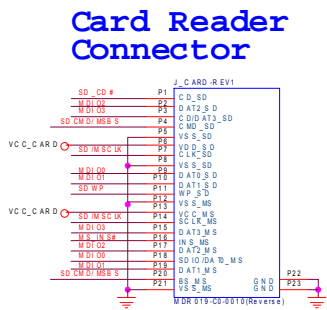
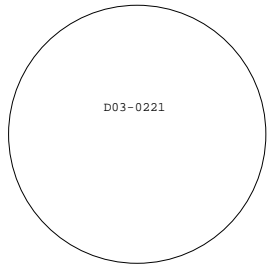
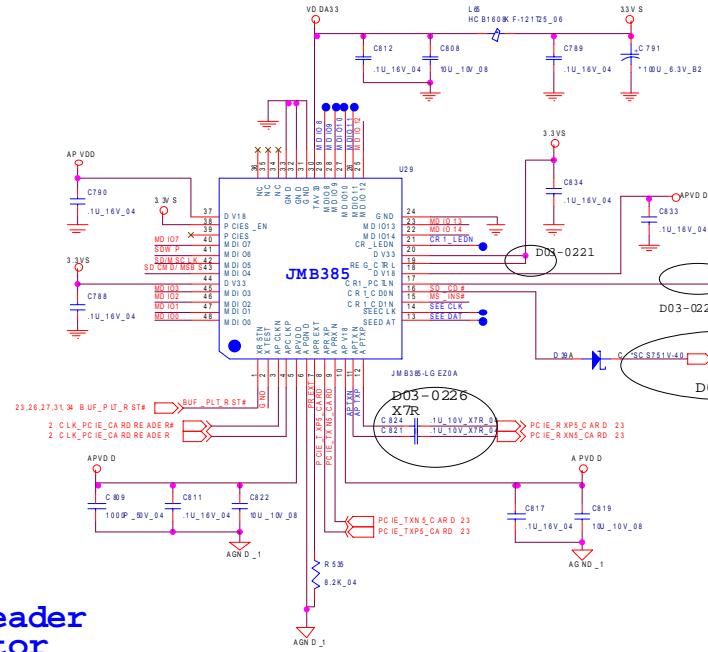
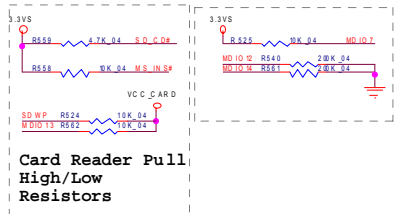

SATA ODD, LED, Hotkey, LID SW

SATA ODD

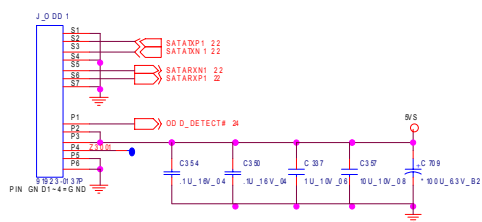

HOT KEY

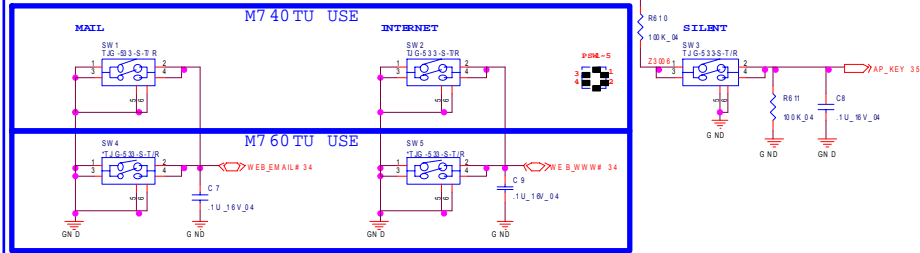

LED

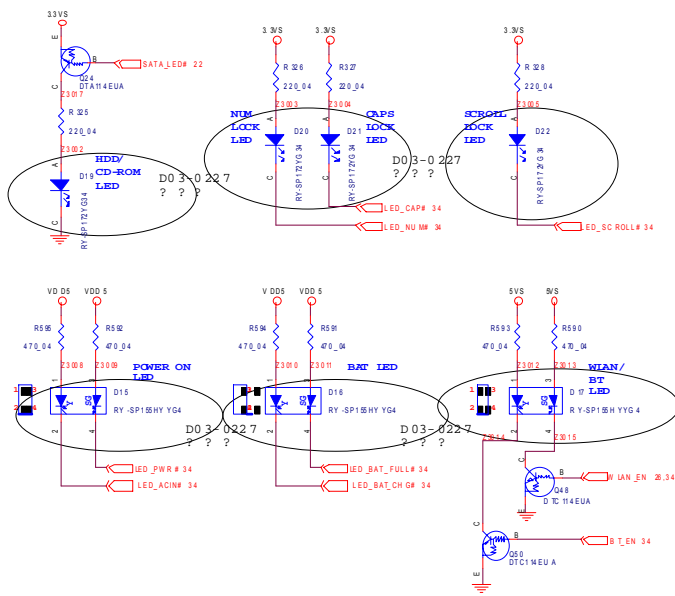

Bluetooth

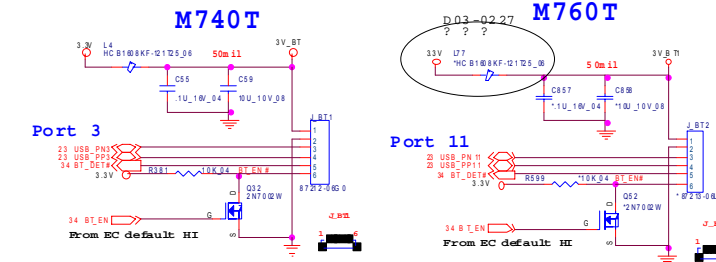

LID SWITCH IC

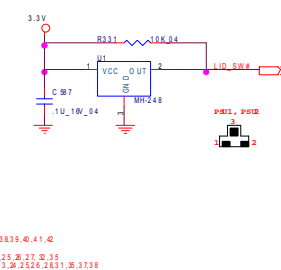

Sheet 30 of 51
SATA ODD, LED,
Hotkey, LID SW

B.Schematic Diagrams

Audio Codec ALC662

CODEC (ALC662-GR)

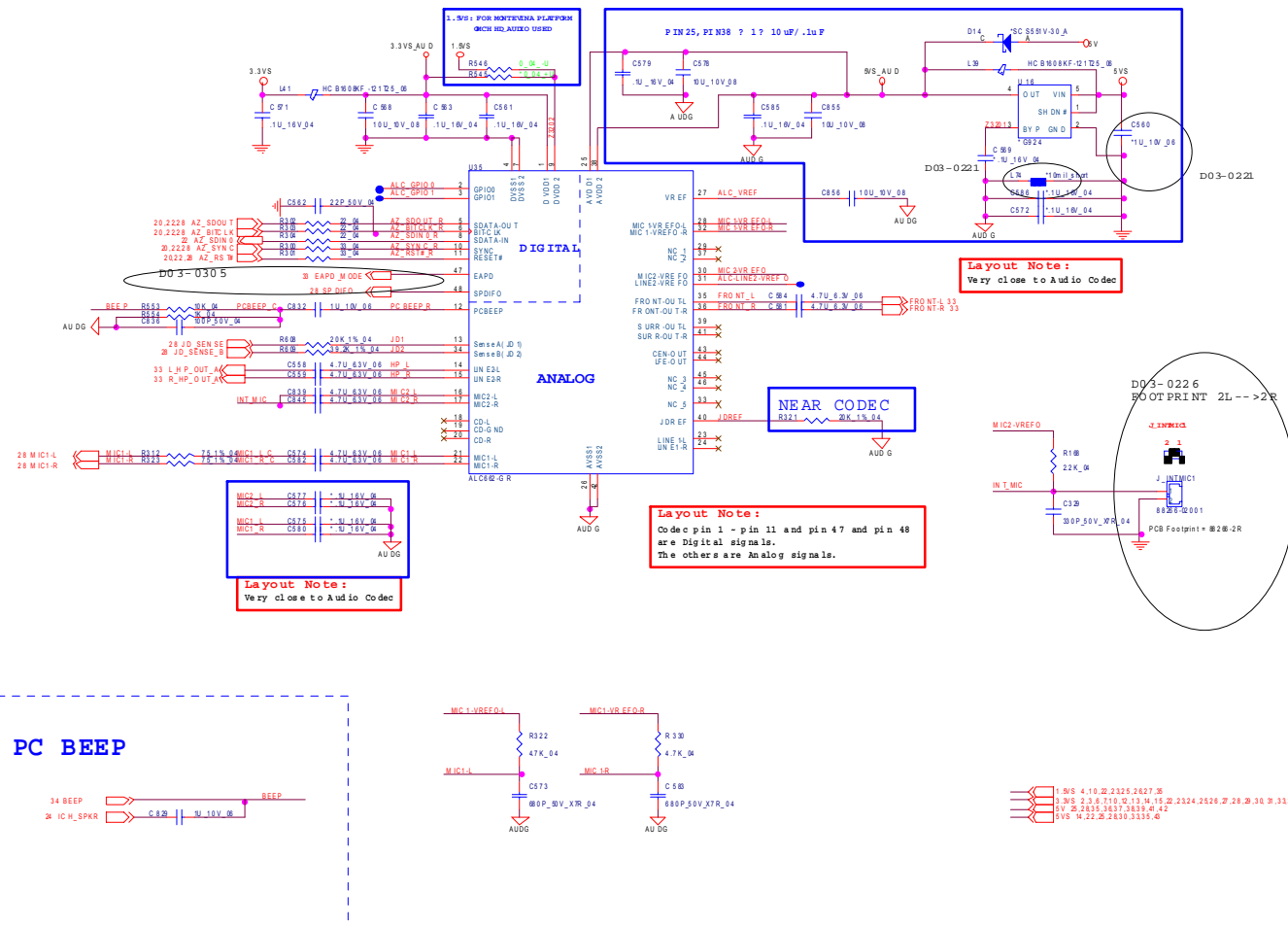

Sheet 32 of 51
Audio Codec
ALC662

B. Schematic Diagrams

Audio AMP

AUDIO AMP

Sheet 33 of 51
Audio AMP

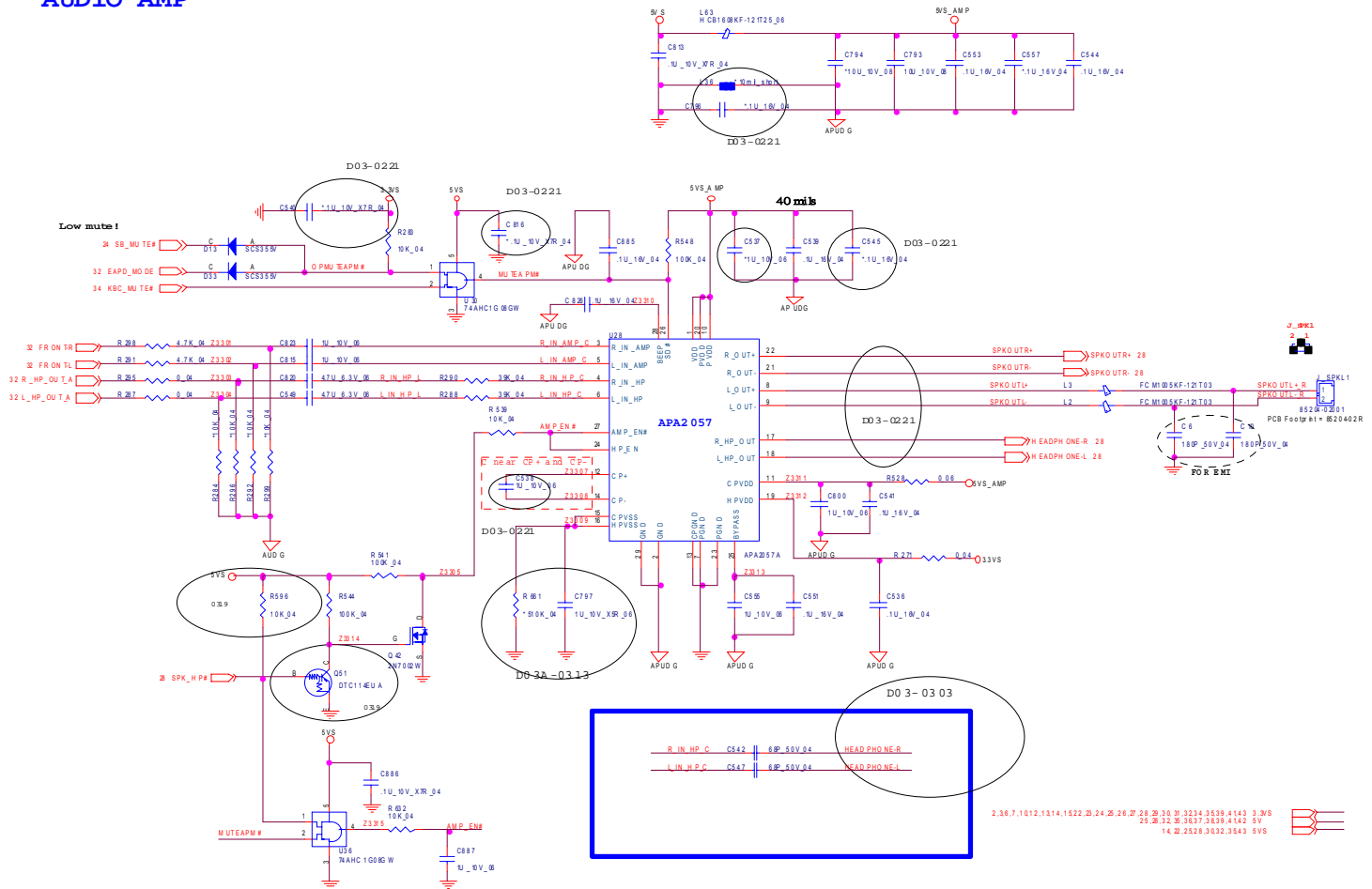

B.Schematic Diagrams

KBC-ITE IT8512E

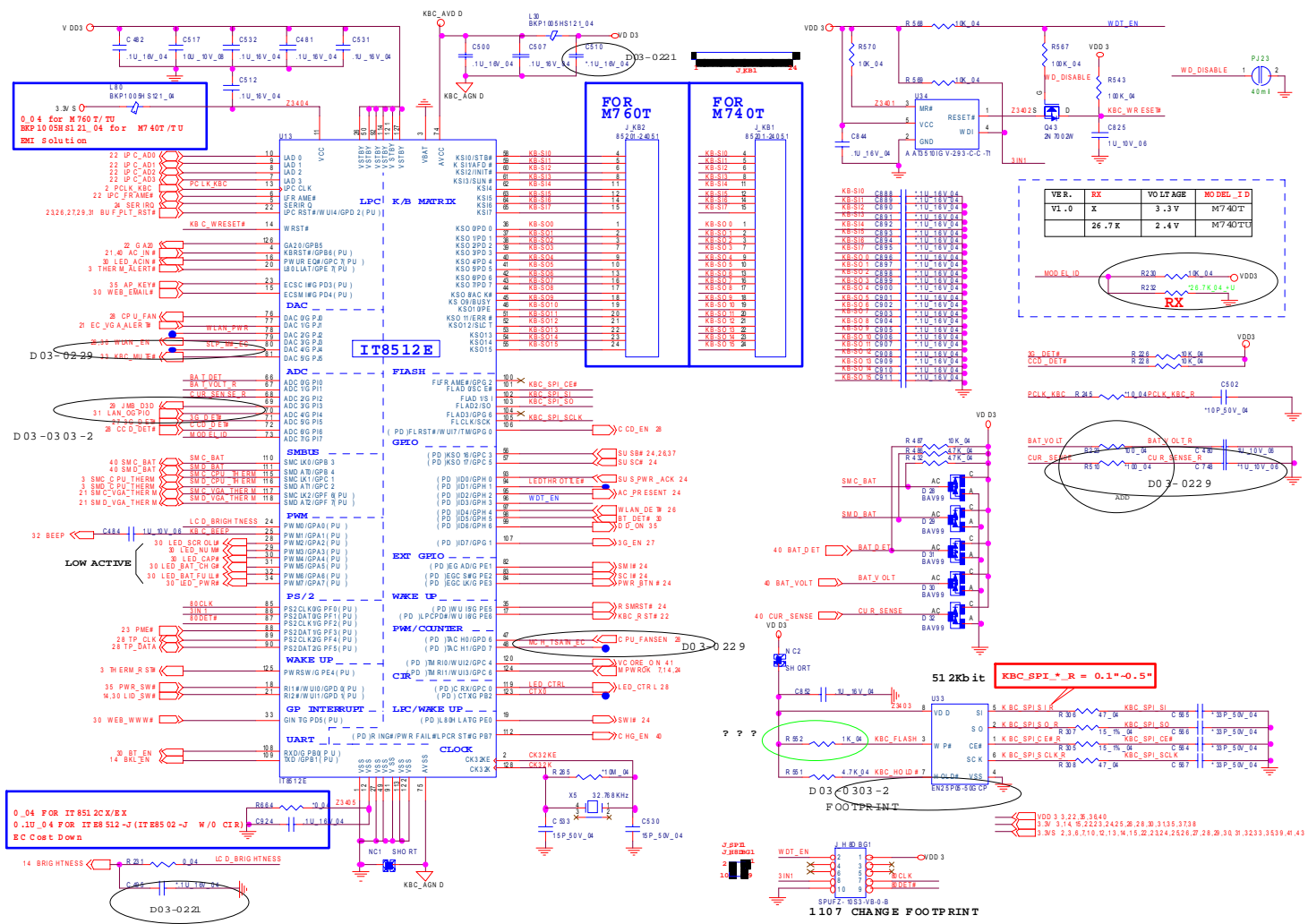

Sheet 34 of 51
KBC-ITE IT8512E

Schematic Diagrams

5VS, 3VS, 3.3VM, 1.05VS, VIN1

Sheet 35 of 51
5VS, 3VS, 3.3VM,
1.05VS, VIN1

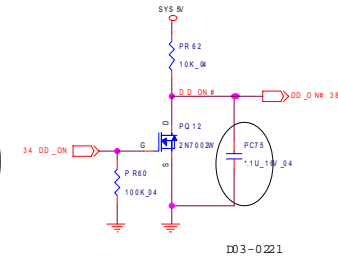
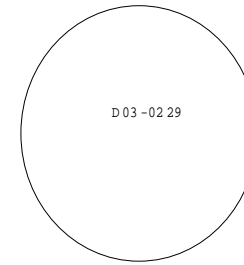
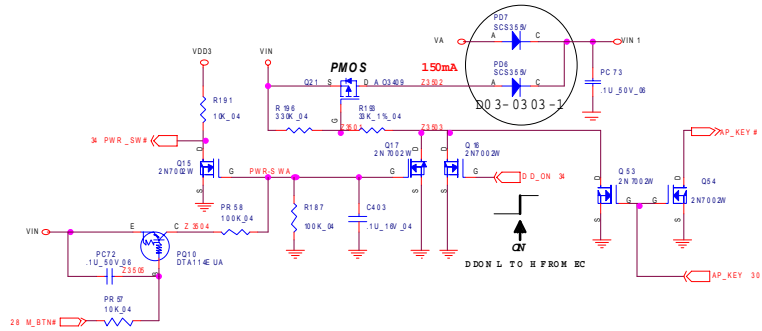

5V

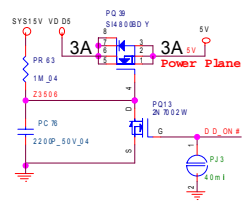

5VS

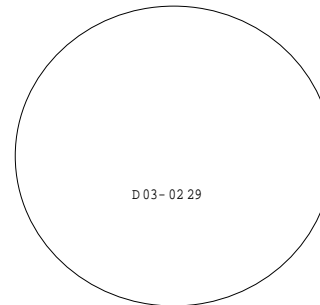
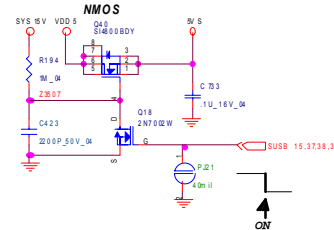

1.05VS

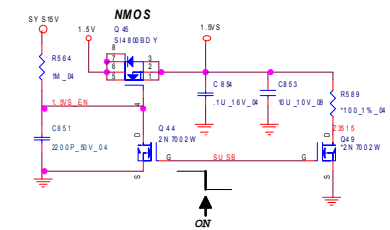

3.3V

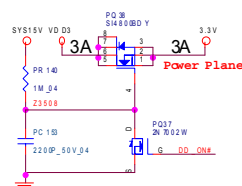

3.3VS

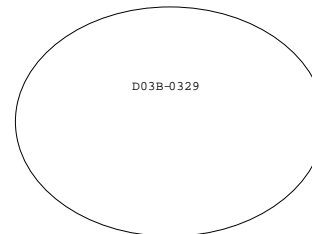
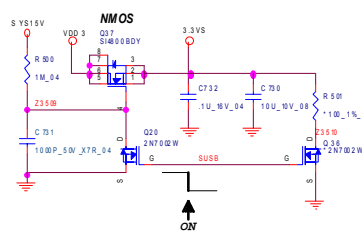

- 1.0V 2,28,37
- 1.5V 410,2223,24,28,27,32
- 1.05VS 2,3,4,5,79,10,22,25,37,39
- SYS5V 38,3740,42
- 3.3V 314,1622,2324,2526,28,30,31,37,38
- VIN1 35
- VIN 4,39,38,37,39,40,41,42
- VA 48
- VDD 5
- VDD 3 122,3436,40
- SYS 1422,2926,3852,33,4
- 3.3V 23,47,1812,13,17,1222,2324,2526,27,28,29,30,31,32,33,34,39,41,43
- SYS15V 14,16,36

Power 3.3V/5V

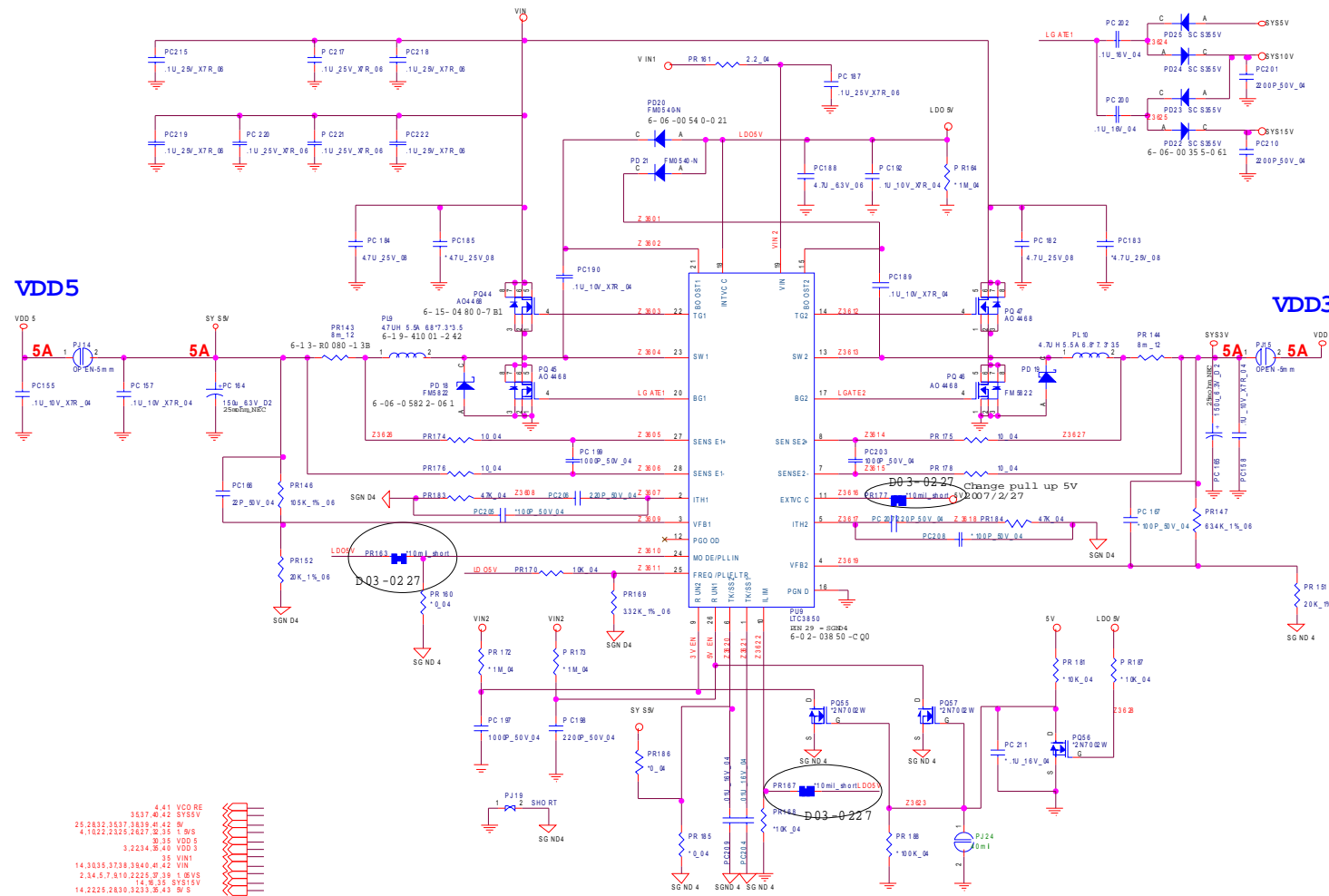

Sheet 36 of 51
Power 3.3V/5V

Schematic Diagrams

Power 1.5VS/1.05VS

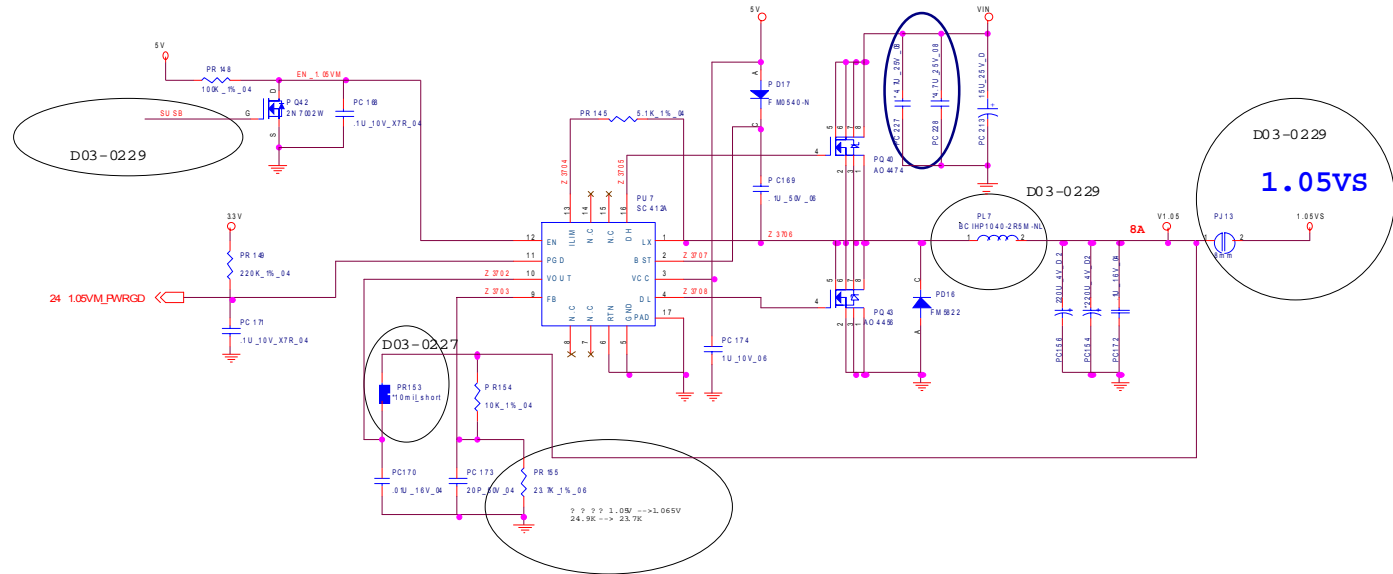

Sheet 37 of 51
Power 1.5VS/
1.05VS

B.Schematic Diagrams

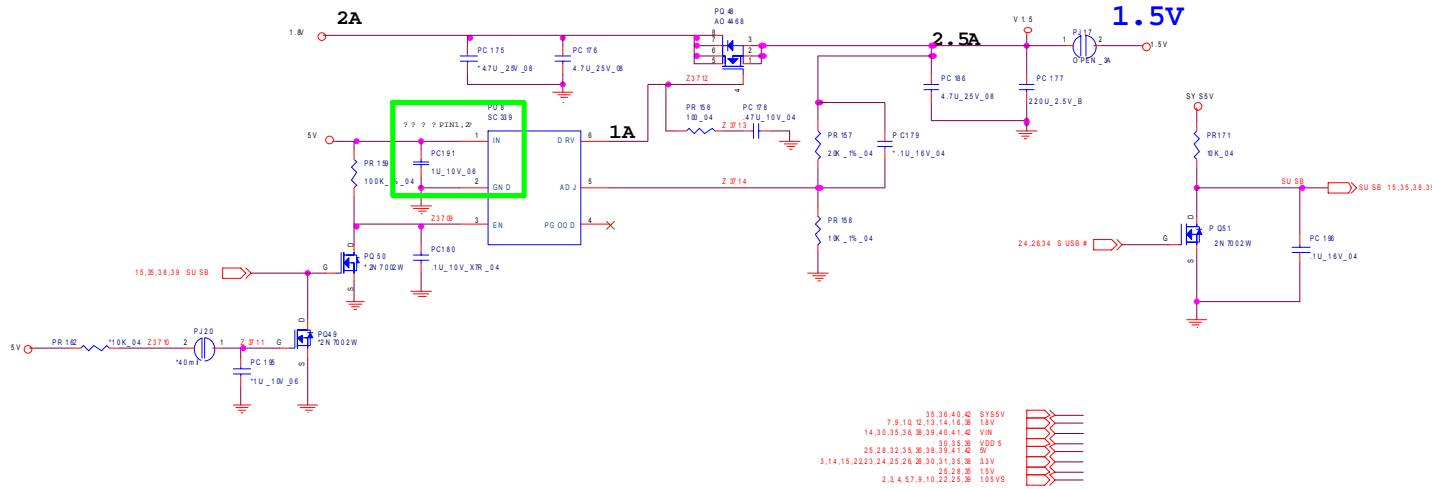

Power 1.8V/0.9V

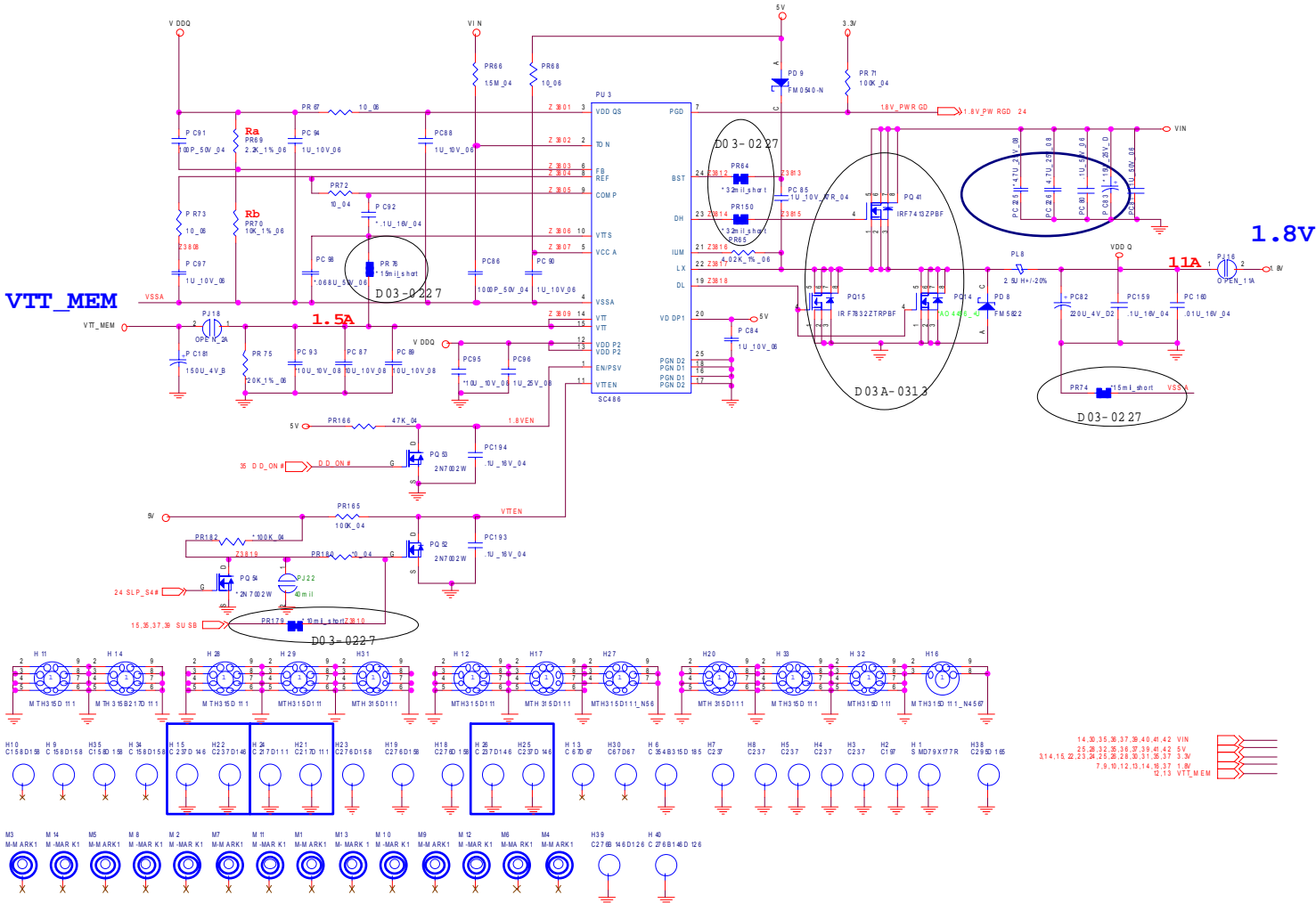

Sheet 38 of 51
Power 1.8V/0.9V

B. Schematic Diagrams

Power GPU/NVVDD

Sheet 39 of 51
Power GPU/NVVDD

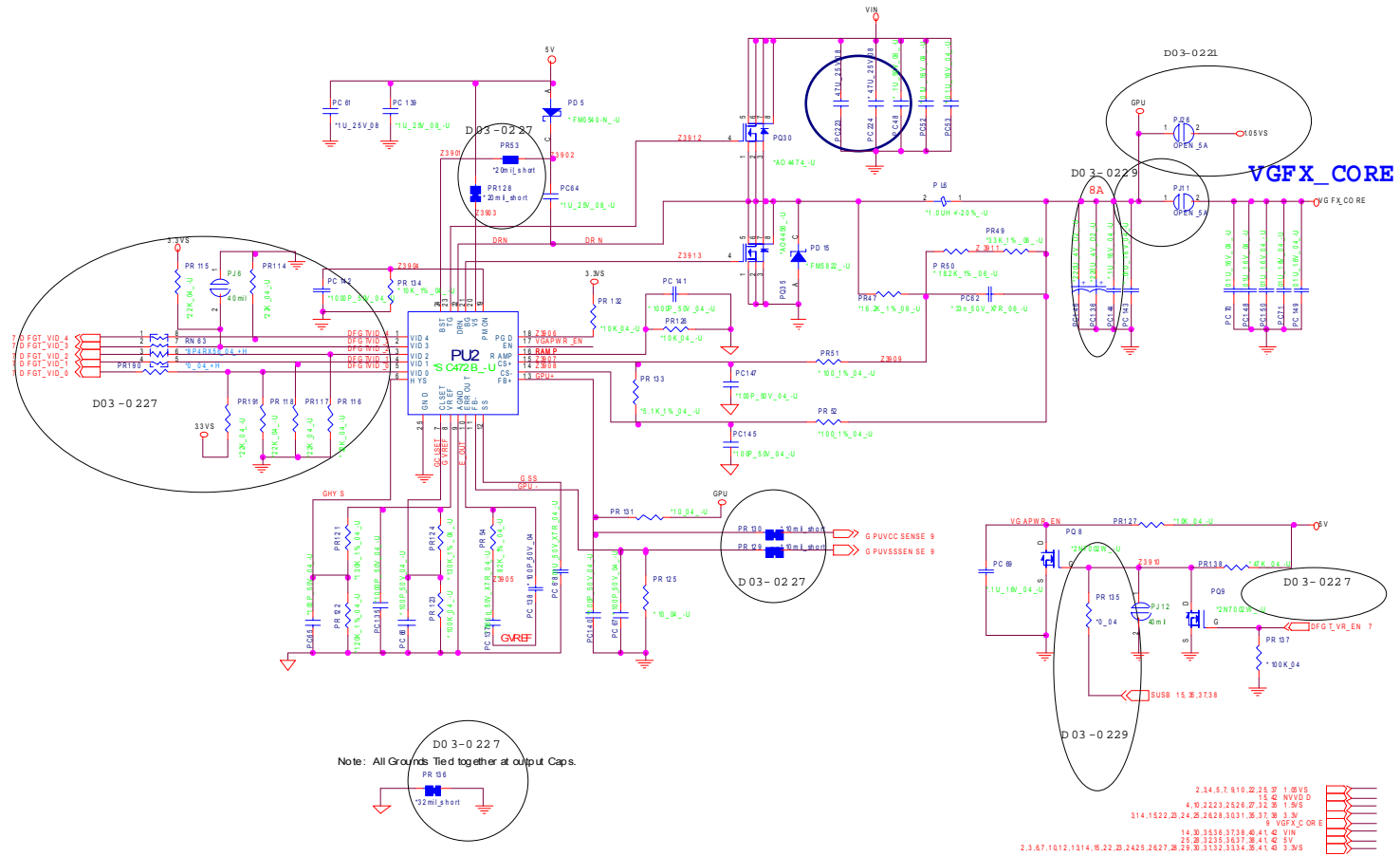

AC-IN, Charger

B.Schematic Diagrams

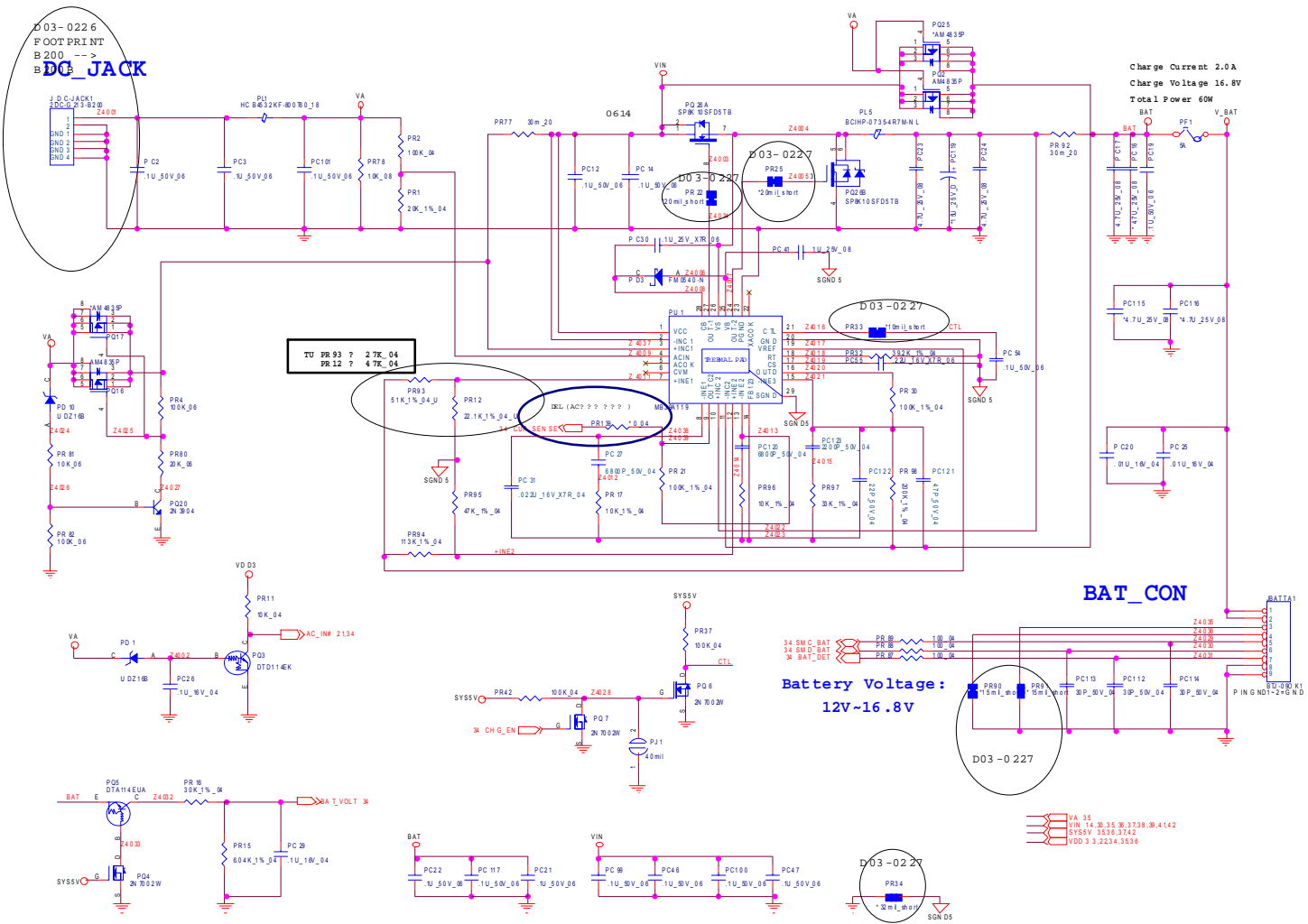

Sheet 40 of 51
AC-IN, Charger

NVVDD

FOR NV VGA

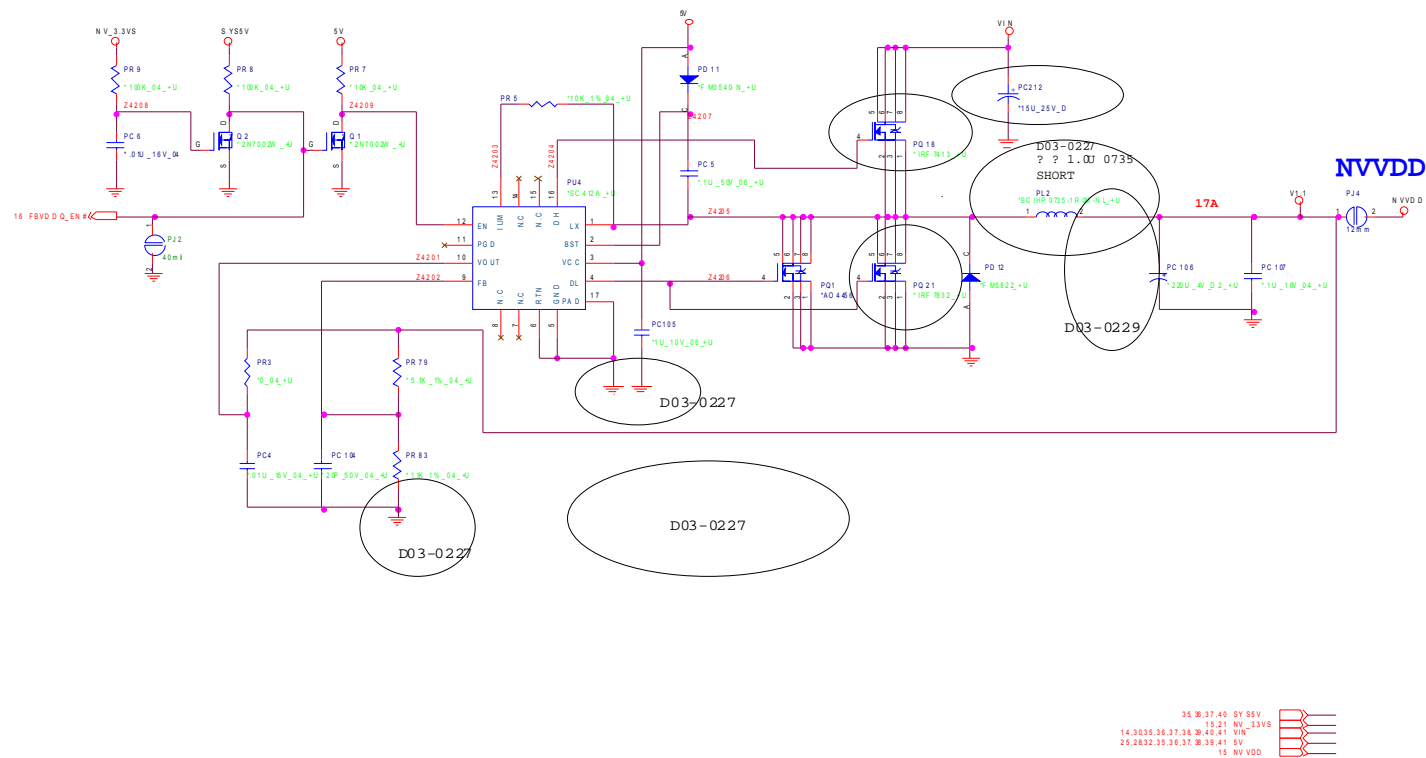

Sheet 42 of 51
NVVDD

B.Schematic Diagrams

Schematic Diagrams

HDMI

HDMI CONNECTOR

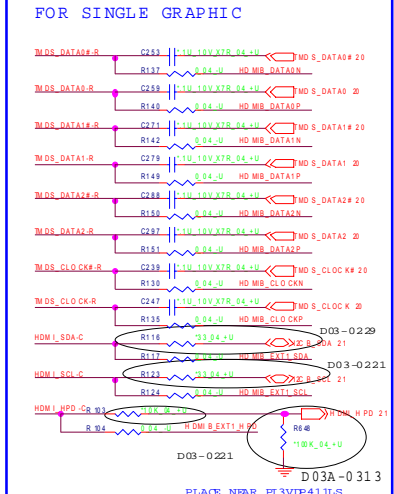
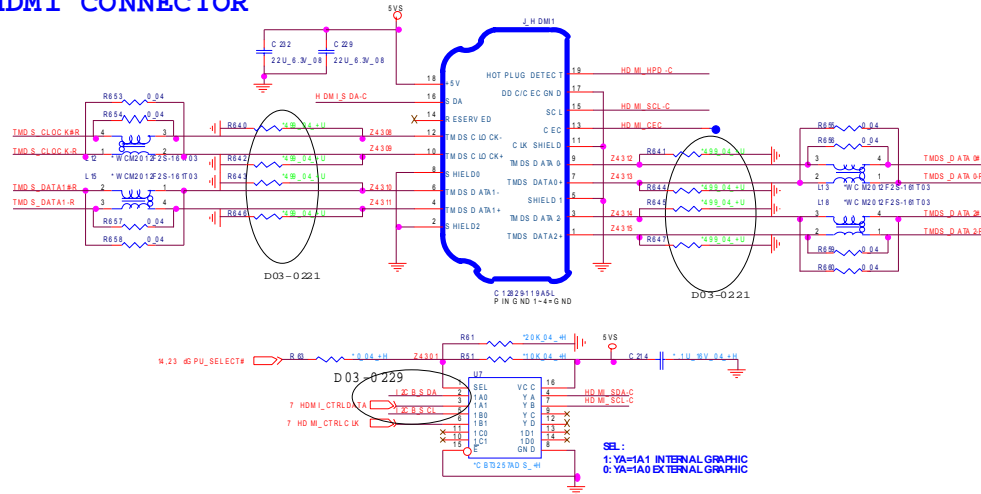

Sheet 43 of 51
HDMI

B.Schematic Diagrams

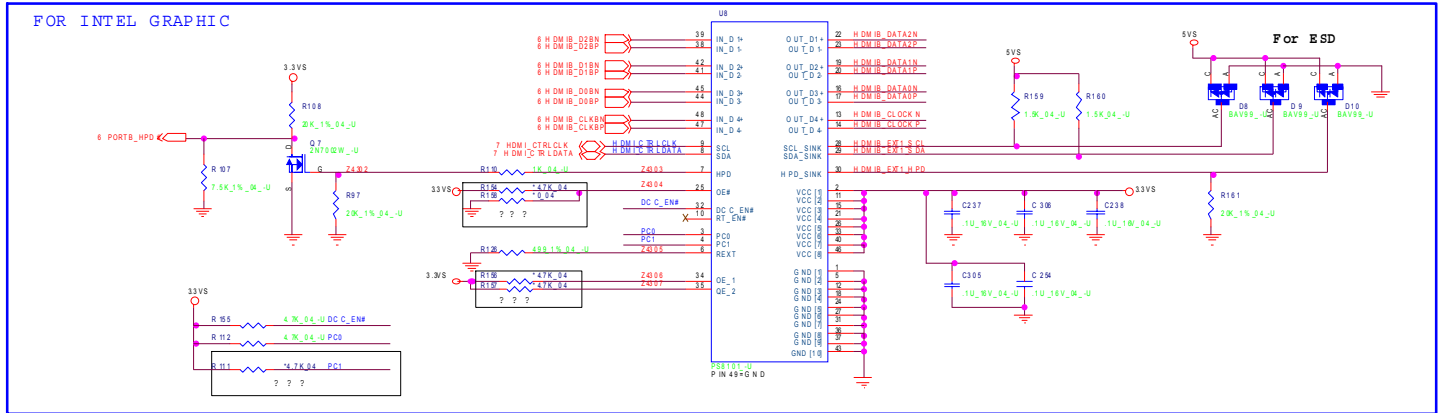

External ODD Board for M76

ODD BOARD

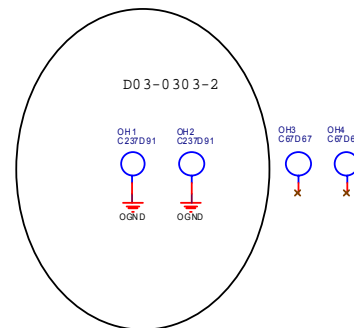
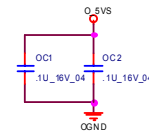
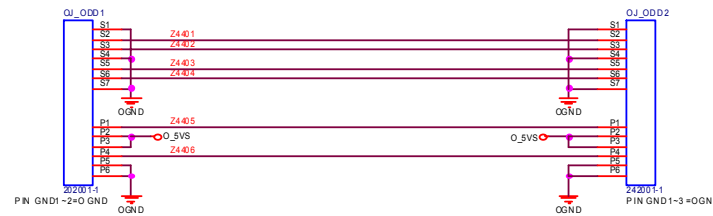

Sheet 44 of 51
External ODD
Board for M76

B.Schematic Diagrams

Click & Finger Board for M76

Sheet 45 of 51
Click Finger Board
for M76

CLICK BOARD

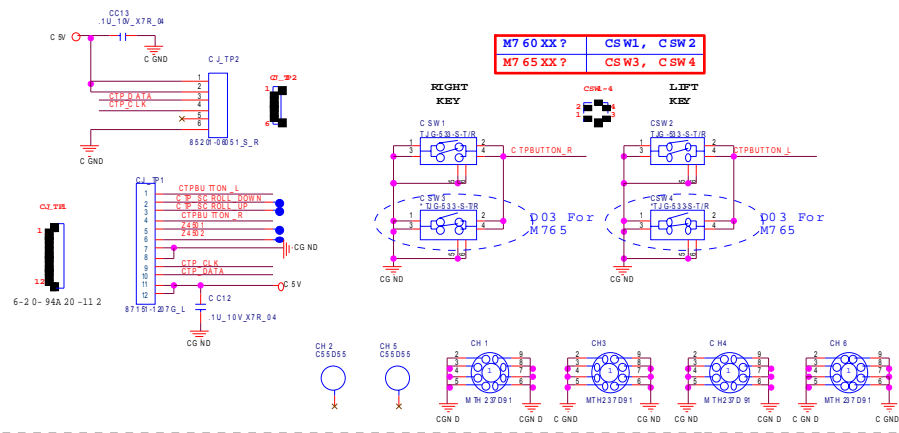

FINGER BOARD

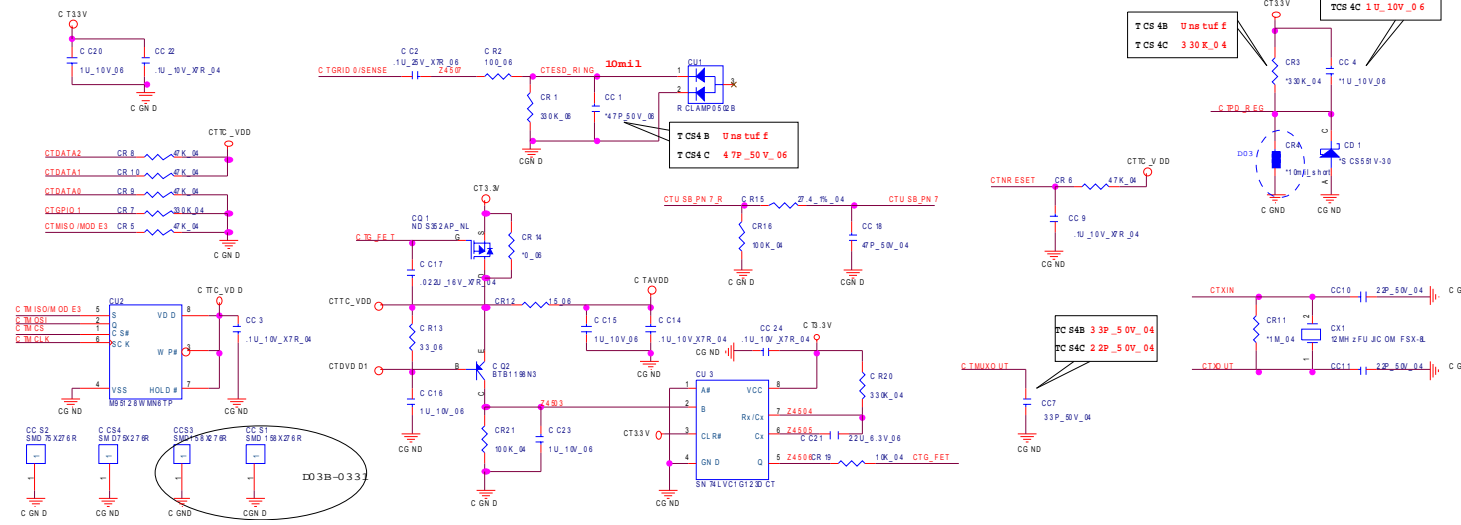
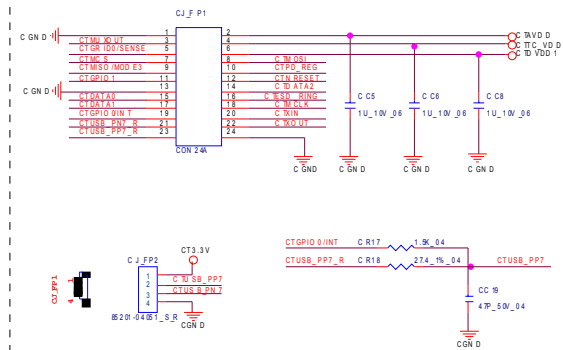

Audio Board

Sheet 47 of 51
Audio Board

USB PORT

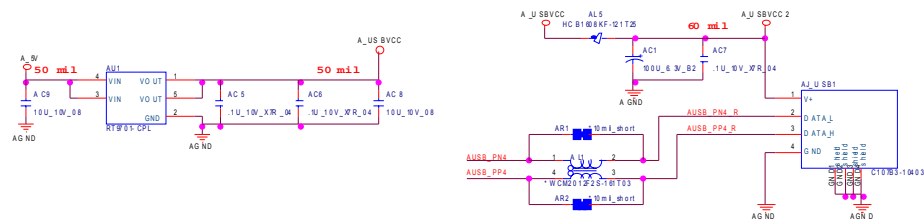

AUDIO JACK

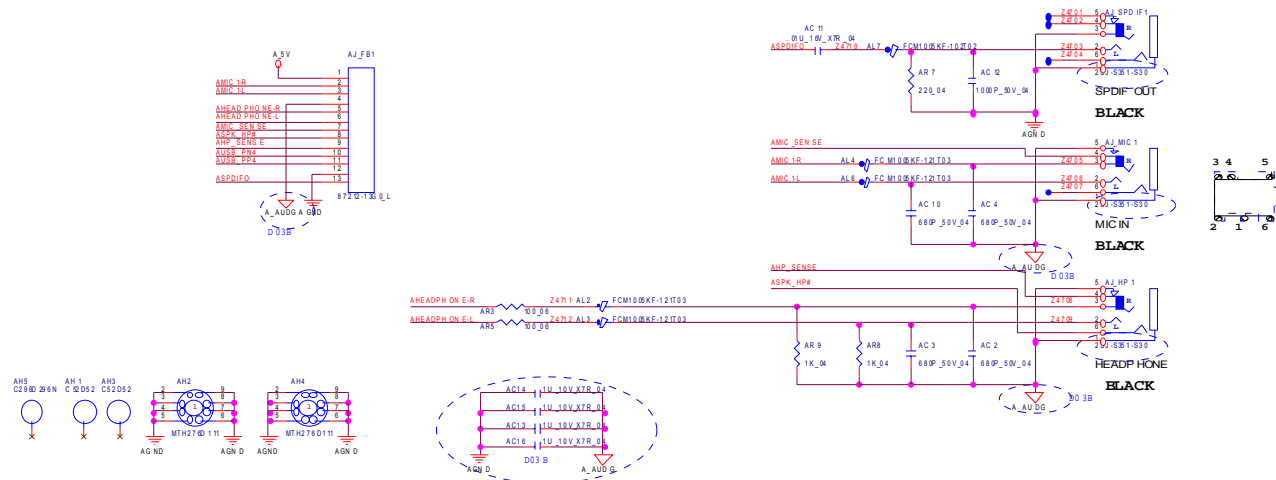

Finger Sensor Board for M76

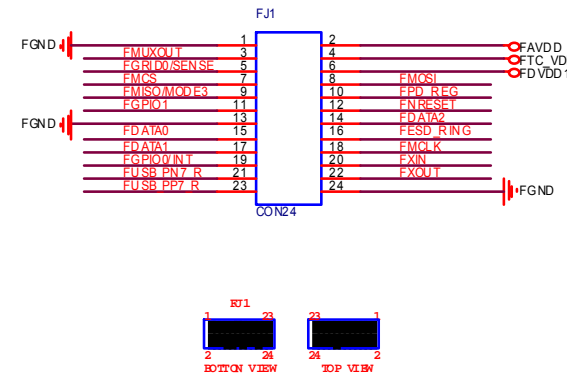
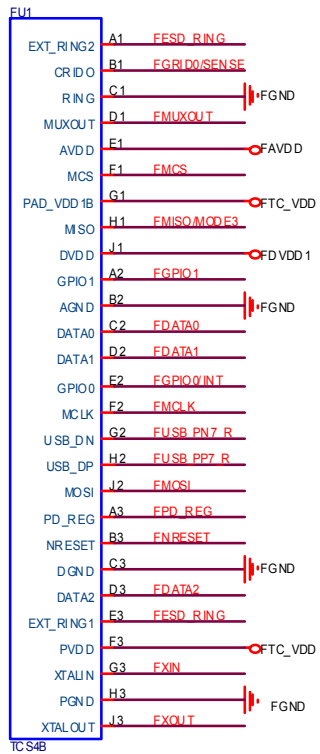

Sheet 48 of 51
Finger Sensor
Board for M76

Power Switch Board for M74

POWER SW & POWER LED FOR M74

Sheet 49 of 51
Power Switch
Board for M74

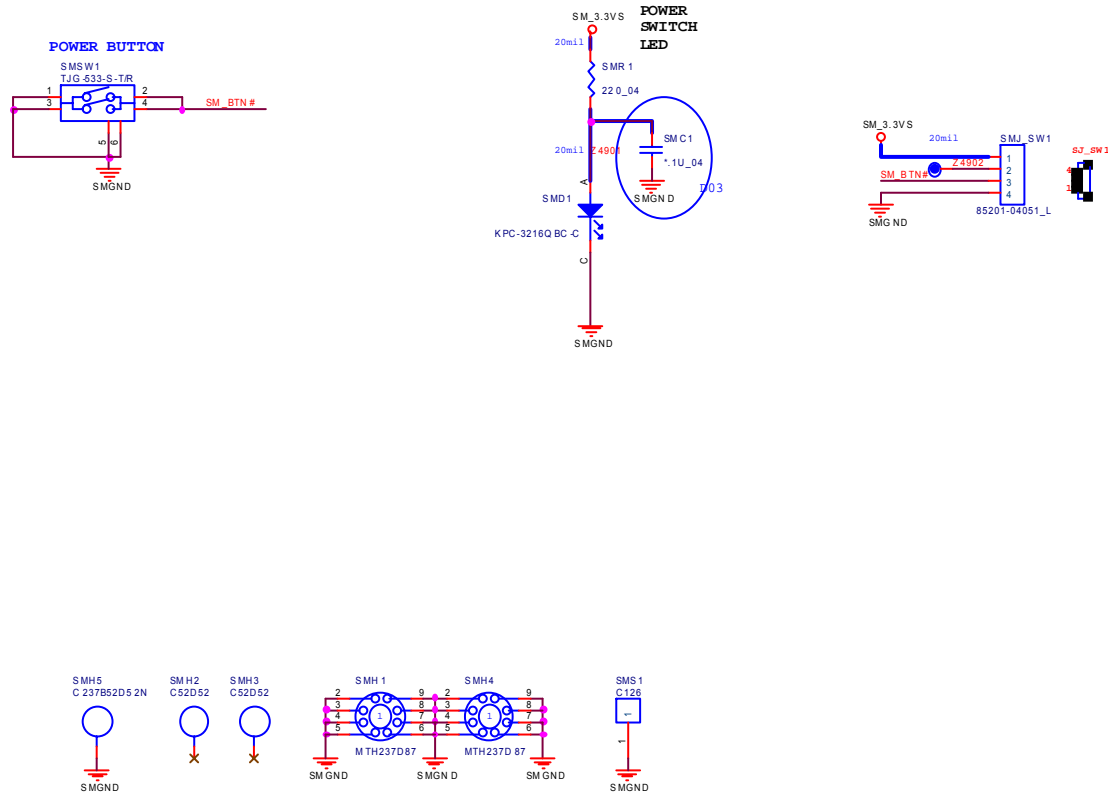

FingerPrint Board for M74

FINGER BOARD FOR M74

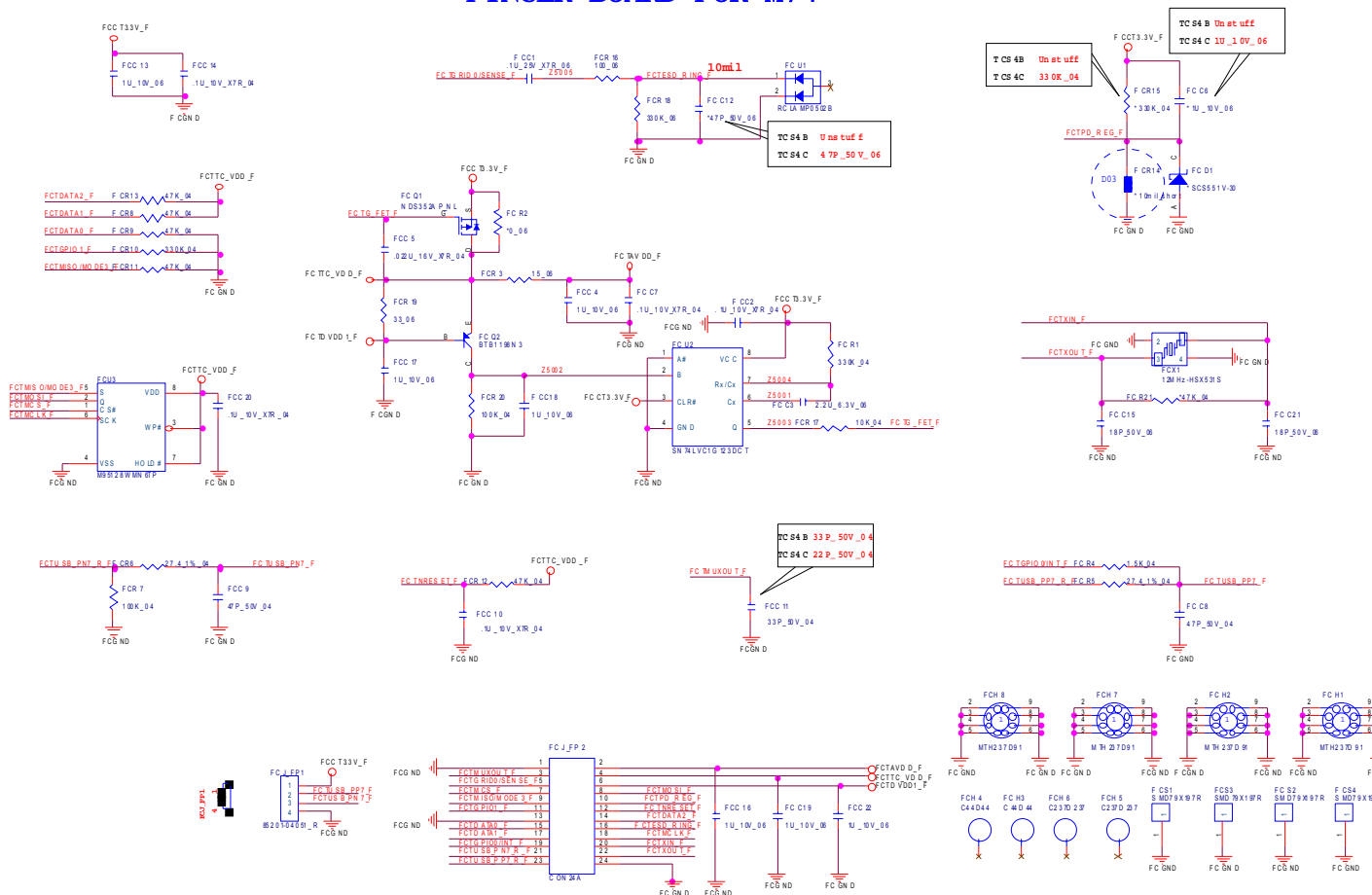

Sheet 50 of 51
FingerPrint Board
for M74

B.Schematic Diagrams

Power Switch Board for M76

POWER SW & POWER LED FOR M76

Sheet 51 of 51
Power Switch
Board for M76

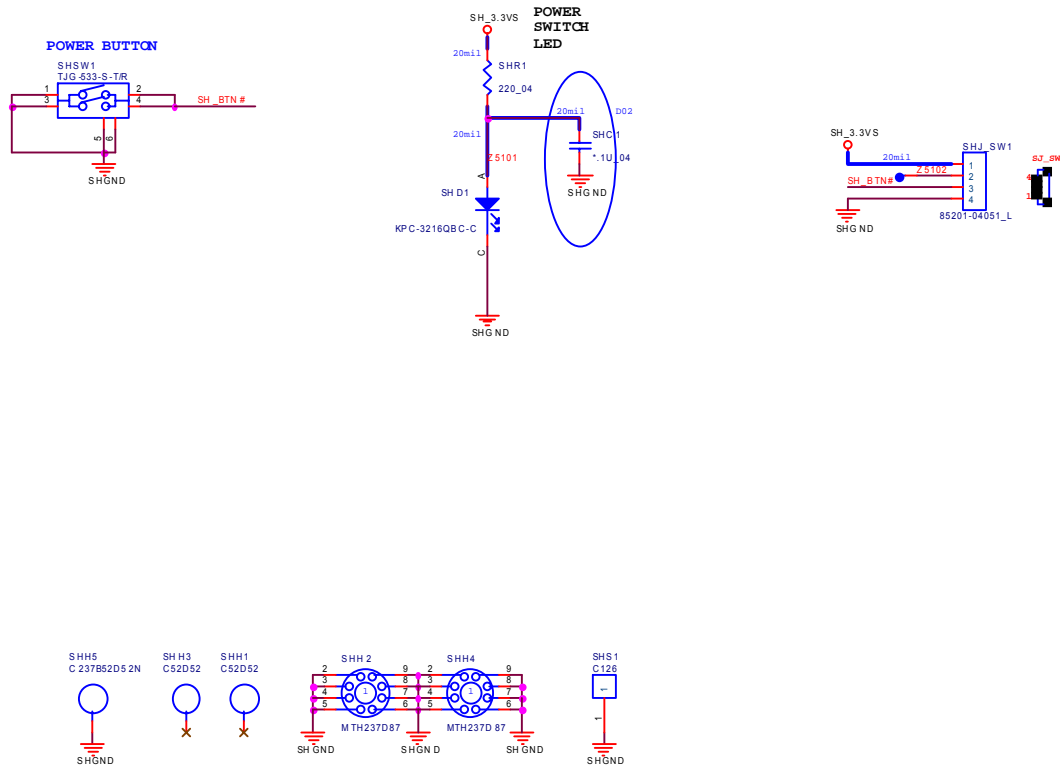

Free Manuals Download Website

<http://myh66.com>

<http://usermanuals.us>

<http://www.somanuals.com>

<http://www.4manuals.cc>

<http://www.manual-lib.com>

<http://www.404manual.com>

<http://www.luxmanual.com>

<http://aubethermostatmanual.com>

Golf course search by state

<http://golfingnear.com>

Email search by domain

<http://emailbydomain.com>

Auto manuals search

<http://auto.somanuals.com>

TV manuals search

<http://tv.somanuals.com>