

I f y o u l e t y o u r e a r s d e c i d e . . .



Owners guide DLS Sub 3.10

Home Entertainment

DLS - Sweden

www.dls.se
Thank you for choosing DLS
enjoy...

Owners guide for DLS Sub 3.10 subwoofer

Introduction

Please read this manual fully before unpacking and installing the product. It will help you to optimise the performance of your subwoofer.

Unpacking and maintenance

Your speaker should be treated with the same care you would treat a piece of furniture. Use only a piece of soft cloth and a small quantity of warm soapy water to clean the loudspeakers. Avoid touching the cone of the bass unit. After unpacking, we suggest you retain all packing material for future transports.

System

DLS Sub 3.10 is an efficient, active subwoofer with a built-in 160 W highcurrent power amplifier. The loudspeaker unit is a specially developed 10" long-stroke woofer with a powerful magnetic system. DLS Sub 3.10 is designed to interact with Hi-Fi equipment, surround installations and multi-media systems. The subwoofer allows great freedom in placement. With the controls you can adjust crossover frequency, level and phase, which makes it easy to adjust for the acoustics in your listening room.

IMPORTANT!

Before connecting electricity to the power supply, it is important that the POWER switch is OFF and check so the AC switch 115V-230V is set at correct voltage for your country. Connect the subwoofers input signals before you switch the POWER switch to ON.

Connection alternatives:

Surround system connections

Surround amplifier provide a separate subwoofer line output, use a "Line Cable" from this output to LINE IN right (R), fig 3. You can also use a "Split Cable" to connect the subwoofer line output to both LINE IN, left (L) and right (R), fig 4. The sensitivity then increases with 6 dB.

2-channel stereo connections

-Line level input

Should your amplifier have separate pre-amplifier outputs, you should connect those to LINE IN, left (L) and right (R). Use a "Stereo Line Cable". Your front speakers remain connected to the loudspeaker outputs of the stereo amplifier.

-High level input

Connect the speaker outputs of the stereo power amplifier to "left HI LEVEL IN" and "right HI LEVEL IN" respectively, fig 2.

Description of subwoofer amplifier, fig 1.

LOW-PASS CROSSOVER

Control for adjusting crossover point to system

POWER LED

Red for standby and green for subwoofer active

VOLUME

Control for adjusting subwoofer level to system

EQ

Switch for EQ on-off

PHASE

Control for adjusting phase 0-180°

LINE LEVEL IN

Connectors for line level RCA input

SPEAKER LEVEL INPUT

For connection from amplifiers speaker output

POWER

Main power switch and power input socket with fuse holder

MAIN SWITCH (red)

To adjust amplifier for 115 or 230V connections

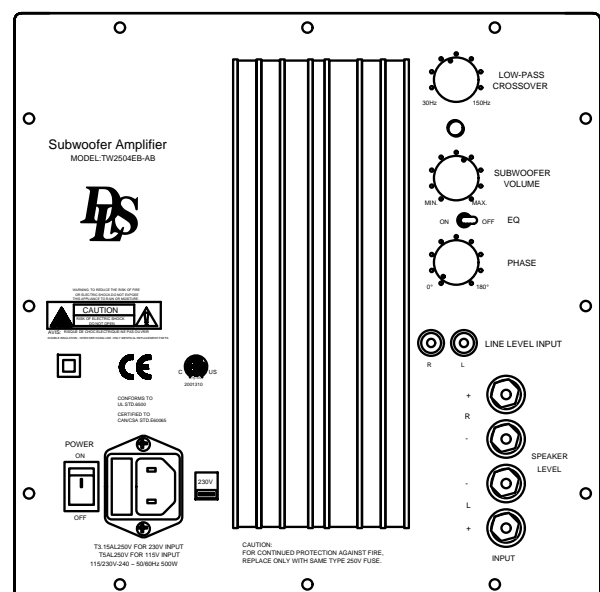

fig 1

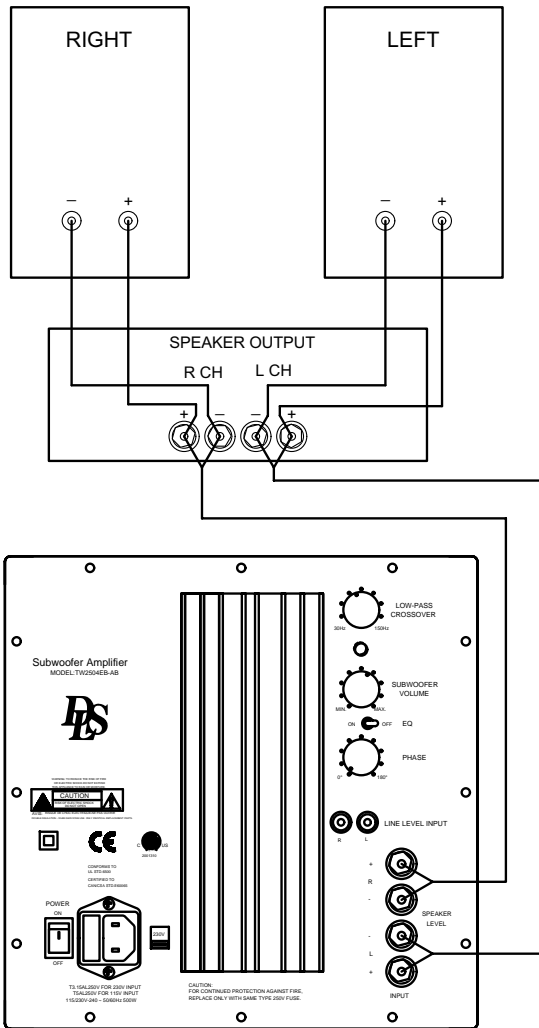

fig 2

Connecting power supply

The switch "Power" is the on/off switch for the subwoofer. Normal position is ON which makes the subwoofer start with the rest of your system, POWER LED glows green. After a period without input signal the amplifier automatically reverts to standby, POWER LED glows red. The OFF position is used when the subwoofer should not be used for some time.

Tuning the system

Running-in period

The performance of the subwoofer will change subtly during the listening period. Please allow your new subwoofer to play about 50 hours of music at normal listening level before doing any critical listening.

Placement

The bass reproduction in a room is the result from many factors. The performance of the subwoofer, the dimensions of the room and the placement of the subwoofer. The most important factor is probably where in the room the subwoofer is placed. The character will change as you move the subwoofer around, small changes in positions - 20cm can have a significant effect on the sound. We recommend that you try out what give maximum performance in your room; by a wall, in a corner or a free-standing position.

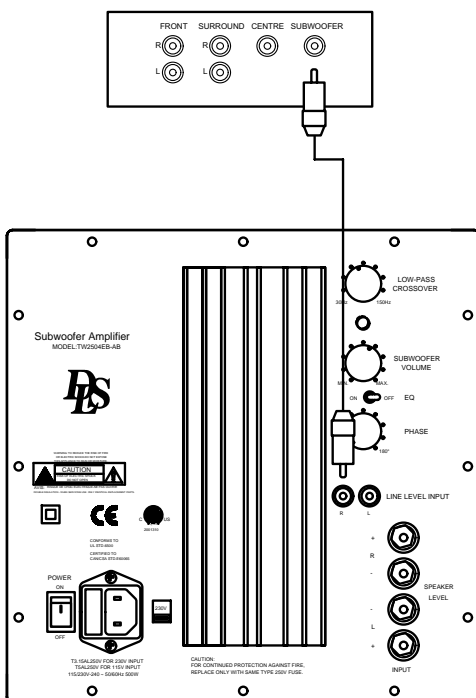

fig 3

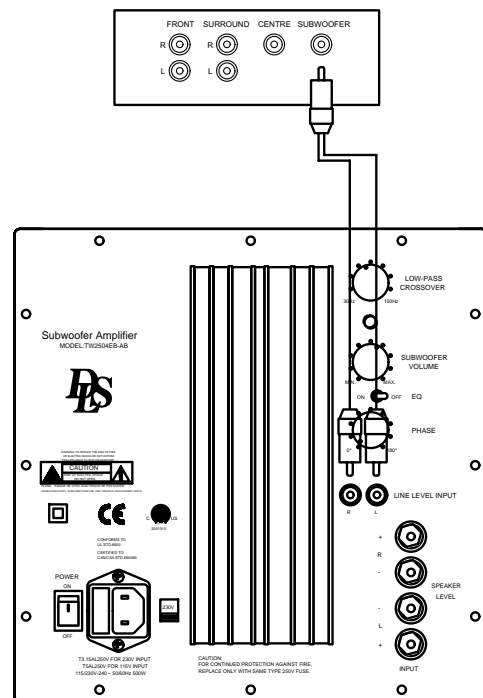

fig 4

VOLUME control

This control is used to adjust the balance between subwoofer and front or satellite speakers. Once you have found a pleasant balance there should be little need for further adjustments. Trust your ears and your personal taste to find the correct setting.

EQ switch.

The EQ change the bass roll-off alignment. For 2-channel switch off is more suitable, that will give a dryer and faster sound. For surround at high level or/and demanding low frequency response switch on can be more suitable.

EQ can also be used to optimise the total bass response in your room. The bass performance is combination of the subwoofer plus the room acoustics. Choose the position that best complements your room and the subwoofers positions. A boomy room switch off can be most suitable, or dry room acoustic can switch on give the best performance.

LOW-PASS CROSSOVER control.

The active crossover network of the DLS Sub 3.10 can be continuously adjusted from 30 to 150 Hz. This frequency is the split frequency between the subwoofer and the front or satellite speakers. A higher crossover frequency eases the load of the front speakers while a lower crossover improves the stereo image. As with the level control you need to try out what suits your equipment, room and ears the best.

PHASE control.

This control changes the phase of the subwoofer sound 180°. Normal position is 0°, but for reasons of placement it could occur that subwoofer and front speakers are out of phase at the crossover frequency. You recognize this as weak bass reproduction that just barely can be adjusted with the level control. Instead you adjust the phase. Start at 0° and then turn it to 180° and start to adjust from the best sounding end position, and again, your ears are the proper instrument to decide.

For other DLS products, Cables, Car Hi-Fi and accessories etc please visit our web site
www.dls.se

DLS home entertainment speaker system are made with pride for your musical enjoyment and comfort

DLS Svenska AB
Sweden
Phone: +46 31 84 00 60
www.dls.se
E-mail: info@dls.se

CAUTION!

If you hear distortion when you increase the volume this is normally a sign of overloading the subwoofer and you should immediately reduce the level. We recommend that you use the volume control with care.

Service

Should your DLS subwoofer system require service, or if you have difficulty in achieving the fine performance of which your DLS loudspeaker system is capable, consult the DLS dealer from whom the system was purchased. Your dealer has the knowledge required to provide expert advice and assistance. In case the DLS dealer is unable to assist you, you are welcome to contact the DLS Technical Department: info@dls.se

Warranty

This DLS loudspeaker is warranted to the original purchaser, against factory defect in material or workmanship, for a period of one (1) year from the date of original purchase. This warranty is valid only in the country of purchase, to the original purchaser and is non-transferable. DLS loudspeakers are music listening devices and should be used for listening purposes only. They must not be connected to any other equipment than amplifiers within the specified power range. DLS cannot be held responsible for damage or injuries caused by improper use, or use in violation with the recommendations in this leaflet.

Free Manuals Download Website

<http://myh66.com>

<http://usermanuals.us>

<http://www.somanuals.com>

<http://www.4manuals.cc>

<http://www.manual-lib.com>

<http://www.404manual.com>

<http://www.luxmanual.com>

<http://aubethermostatmanual.com>

Golf course search by state

<http://golfingnear.com>

Email search by domain

<http://emailbydomain.com>

Auto manuals search

<http://auto.somanuals.com>

TV manuals search

<http://tv.somanuals.com>