

Model 950

7.1 Channel Preamp/Processor



Owner's Manual

Version 1.2.6

Please Read First



CAUTION: To reduce the risk of electric shock, do not remove the cover. No user serviceable parts inside. Refer to qualified personnel.

WARNING: To reduce the risk of fire or electric shock, do not expose this appliance to rain or moisture.



The lightning flash with arrowhead, within an equilateral triangle, is intended to alert the user to the presence of uninsulated "dangerous voltage" within the product's enclosure that may be of sufficient magnitude to constitute a risk of electrical shock to persons.



The exclamation point within an equilateral triangle is intended to alert the user to the presence of important operating maintenance (servicing) instructions in the literature accompanying the appliance.

WARNING: Important Safeguards

- **Read Instructions**—All the safety and operating instructions should be read before the unit is operated.
- **Retain Instructions**—The safety and operating instructions should be retained for future reference.
- **Heed Warnings**—All warnings on the unit and in the operating instructions should be adhered to.
- **Follow Instructions**—All operating and use instructions should be followed.
- **Cleaning**—Unplug the unit from the wall outlet before cleaning. The unit should be cleaned only as recommended by the manufacturer.
- **Attachments**—Do not use attachments not recommended by the unit manufacturer as they may cause hazards.
- **Water and Moisture**—Do not use the unit near water—for example, near a bath tub, wash bowl, kitchen sink, or laundry tub; in a wet basement; or near a swimming pool.
- **Accessories**—Do not place the unit on an unstable cart, stand, tripod, bracket, or table. The unit may fall, causing serious injury to a child or adult, and serious damage to the unit. Any mounting of the unit should follow the manufacturer's instructions, and should use a mounting accessory recommended by the manufacturer.
- **Ventilation**—Slots and openings in the cabinet are provided for ventilation and to ensure reliable operation of the unit and to protect it from overheating, and these openings must not be blocked or covered. The openings should never be blocked by placing the unit on a bed, sofa, rug, or other similar surface. The unit should not be placed in a built-in installation such as a bookcase or rack unless proper ventilation is provided. There should be free space of at least 16 cm (6 in.) and an opening behind the unit.
- **Power Sources**—The unit should be operated only from the type of power source indicated on the marking label. If you are not sure of the type of power supplied to your home, consult your unit dealer or local power company.
- **Grounding or Polarization**—The unit may be equipped with a polarized alternating current line plug (a plug having one blade wider than the other). This plug will fit into the power outlet only one way. This is a safety feature. If you are unable to insert the plug fully into the outlet, try reversing the plug. If the plug should still fail to fit, contact a licensed electrician to replace your obsolete outlet. Do not defeat the safety purpose of the polarized plug.
- **Power-Cord Protection**—Power-supply cords should be routed so that they are not likely to be walked on or pinched by items placed upon or against them, paying particular attention to cords where they enter a plug, or a convenience receptacle, and the point

where they exit from the unit.

- **Outdoor Antenna Grounding**—If an outside antenna or cable system is connected to the unit, be sure the antenna or cable system is grounded so as to provide some protection against voltage surges and built-up static charges. Article 810 of the National Electrical Code, ANSI/NFPA 70, provides information with regard to proper grounding of the mast and supporting structure, grounding of the lead-in wire to an antenna-discharge unit, size of grounding conductors, location of antenna-discharge unit, connection to grounding electrodes, and requirements for the grounding electrode.
- **Lightning**—For added protection for the unit during a lightning storm, or when it is left unattended and unused for long periods of time, unplug it from the wall outlet and disconnect the antenna or cable system. This will prevent damage to the unit due to lightning and power-line surges.
- **Power Lines**—An outside antenna system should not be located in the vicinity of overhead power lines or other electric light or power circuits, or where it can fall into such power lines or circuits. When installing an outside antenna system, extreme care should be taken to keep from touching such power lines or circuits as contact with them might be fatal.
- **Overloading**—Do not overload wall outlets, extension cords, or integral convenience receptacles as this can result in a risk of fire or electric shock.
- **Object and Liquid Entry**—Never push objects of any kind into the unit through openings as they may touch dangerous voltage points or short-out parts that could result in a fire or electric shock. Never spill liquid of any kind on the unit.
- **Servicing**—Do not attempt to service the unit yourself as opening or removing covers may expose you to dangerous voltage or other hazards. Refer all servicing to qualified service personnel.
- **Damage Requiring Service**—Unplug the unit from the wall outlet and refer servicing to qualified service personnel under the following conditions:
 - When the power-supply cord or plug is damaged,
 - If liquid has been spilled, or objects have fallen into the unit,
 - If the unit has been exposed to rain or water,
 - If the unit does not operate normally by following the operating instructions. Adjust only those controls that are covered by the operating instructions as an improper adjustment of other controls may result in damage and will often require extensive work by a qualified technician to restore the unit to its normal operation,
 - If the unit has been dropped or damaged in any way, and great care should be exercised in handling, and the unit should be examined by qualified service personnel.
- **When the unit exhibits a distinct change in performance**—this indicates a need for service.
- **Replacement Parts**—When replacement parts are required, be sure the service technician has used replacement parts specified by the manufacturer or have the same characteristics as the original part. Unauthorized substitutions may result in fire, electric shock, or other hazards.
- **Safety Check**—Upon completion of any service or repairs to the unit, ask the service technician to perform safety checks to determine that the unit is in proper operation condition.
- **Wall or Ceiling Mounting**—The unit should be mounted to a wall or ceiling only as recommended by the manufacturer.
- **Heat**—The unit should be situated away from heat sources such as radiators, heat registers, stoves, or other units (including amplifiers) that produce heat.

IMPORTANT SAFETY NOTE

Before connecting a new component such as the Model 950 to your audio or home theater system it is always good practice to make certain that all components are turned off, and preferably unplugged from their AC power source. Many modern electronics products feature automatic turn-on circuits that may be activated during an installation, causing the potential for damage to electronic components and/or speakers. Such damage is not covered by product warranties and Outlaw Audio specifically disclaims responsibility for any such damage.

Precautions

Verify The Line Voltage

Your new Model 950 has been factory configured for 120 (+/- 3%) volt AC lines. Connecting the unit to a line voltage other than that for which it is intended can create a safety and fire hazard, and may damage the Model 950. If you have any questions about the voltage requirements for your specific model, or about the line voltage in your area, contact Outlaw Audio before plugging the unit into a wall outlet.

NOTE: It is always a good idea to avoid using any audio or video equipment on the same AC circuit as equipment with motors, such as air conditioners or refrigerators. This will lessen the possibility of power variation and electrical start-up noise affecting your sound system.

Power Cord

The removable power cord that is shipped with the Model 950 is specifically designed to be used with this product. DO NOT use any other power cord, as that may reduce the unit's performance and possibly create a safety hazard. In particular, DO NOT use standard IEC type power cords designed for computers and other business equipment products, as they have a three prong plug that is not meant for use with the 950. Should the power cord require replacement, use an identical type, or contact Outlaw Audio for service.

Handle the AC Power Cord Gently

When disconnecting the power cord from an AC outlet, always pull the plug, never pull the cord. If you do not intend to use the Model 950 for any considerable length of time, disconnect the plug from the AC outlet. If the power cord is replaced, make certain that it is of similar gauge. As with all electrical devices, do not run power cords under rugs or carpets or place heavy objects on them. Damaged power cords should be replaced immediately with cords meeting factory specifications.

AC Fuse

The fuse is located inside the chassis and is not user-service-able. If power does not come on, contact your authorized service station.

Wiring

Cables that are run inside of walls should have the appropriate markings to indicate compliance with, and listing by the UL, CSA or other standards required by the UL, CSA, NEC or your local building code. Questions about cables inside of walls should be referred to a qualified custom installer, or a licensed electrician or low-voltage contractor.

Installation Location

To assure proper operation and to avoid the potential for safety hazards, place the unit on a firm and level surface capable of supporting its weight. When placing the unit on a shelf, be certain that the shelf and any mounting hardware can support the weight of the unit and any additional items in the equipment rack, or on the shelf.

When positioning the Model 950 in its final location, make certain that it has adequate ventilation on all sides, as well as on the top and bottom. In particular, it is a good idea to provide at least two or three inches of room above the unit for air circulation. DO NOT place CDs, DVDs, videotapes, owner's manuals, or other paper on top of, or beneath, the unit, or in-between multiple amplifiers in a stack. This will block airflow, causing heat build-up, degraded performance, and may create a possible fire hazard.

If the unit is to be enclosed in a cabinet or rack, make certain there is adequate air circulation. Sufficient ventilation should be provided so that hot air may exit, and cool air may enter the cabinet. In some instances, a small cooling fan may be required to insure adequate airflow through the cabinet. If you are in doubt as to the ventilation requirements for your specific installation, please contact us. Also, do not place the Model 950 directly on a carpeted surface, as this will inhibit airflow underneath as well as create a potential fire hazard.

Avoid installation in humid locations, in extremely hot or cold locations, or in areas that are exposed to direct sunlight or space heating equipment.

Do Not Open The Cabinet

There are no user serviceable components inside this product. Opening the cabinet may present a shock hazard, and any modification to the product will void your guarantee. If water or any metal object, such as a paper clip, coin or a staple, accidentally falls inside

the unit, disconnect it from the AC power source immediately, and contact Outlaw Audio for further instructions.

Recording Copyright

Recording of copyrighted material for other than personal use is illegal without permission of the copyright holder.

Note to CATV system installer

This reminder is provided to call the CATV system installer's attention to Article 820-40 of the NEC, ANSI/NFPA 70, which provides guidelines for proper grounding and, in particular, specifies that the cable ground shall be connected to the grounding system of the building, as close to the point of cable entry as practical.

FCC Information for User

CAUTION: ANY changes or modifications not expressly approved by the party responsible for compliance could void the user's authority to operate the equipment.

NOTE: This equipment has been tested and found to comply with the limits for a Class B digital device, pursuant to Part 15 of the FCC Rules. These limits are designed to provide reasonable protection against harmful interference in a residential installation.

This equipment generates, uses and can radiate radio frequency energy and, if not installed and used in accordance with the instructions, may cause harmful interference to radio communications. However, there is no guarantee that interference will not occur in a particular installation.

If this equipment does cause harmful interference to radio or television reception, which can be determined by turning the equipment off and on, the user is encouraged to try to correct the interference by one or more of the following measures:

Reorient or relocate the receiving antenna.

Increase the separation between the equipment and receiver.

Connect the equipment into an outlet on a circuit different from that to which the receiver is connected.

Outdoor Antenna Installation

Safe Antenna and cable Connection

If an outside antenna or cable system is connected to the equipment, be sure the antenna or cable system is grounded so as to provide some protection against built up static charges and voltage surges. Section 810 of the national Electrical Code, ANSI/NFPA 70 (in Canada, part 1 of the Canadian Electrical Code) provides information with respect to proper grounding of the mast and supporting structure, grounding of the lead-in wire to an antenna discharge unit, size of grounding conductors, location of antenna discharge unit, connection to grounding electrodes and requirements for the grounding electrode.

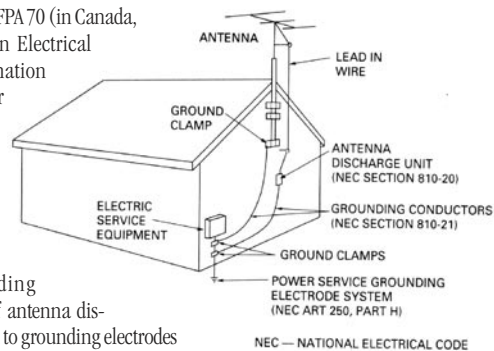

Keep Antenna Clear of High Voltage Power Lines or Circuits

An outside antenna system should be located well away from power lines, electric light or power circuits and where it will never come into contact with these power sources if it should happen to fall. When installing an outside antenna, extreme care should be taken to avoid touching power lines, circuits or other power sources as this could be fatal. Because of the hazards involved, antenna installation should be left to a professional.

Table of Contents

| | | |
|-----------|--|--|
| 2 | Please Read First | |
| 5 | Model 950 Features | |
| 6 | Unpacking | |
| 6 | Accessories | |
| 6 | Model 950 Front Panel | |
| 8 | Model 950 Rear Panel | |
| 9 | Front Panel and On Screen Display (OSD) | |
| 10 | Remote Control | |
| 12 | Surround Format Information | |
| 12 | Dolby Digital | |
| 12 | Dolby Digital Surround EX | |
| 12 | Dolby Pro Logic II | |
| 12 | DTS | |
| 12 | DTS-ES | |
| 13 | DTS NEO:6 | |
| 13 | Cirrus Extra Surround | |
| 13 | Stereo | |
| 13 | Additional Information | |
| 13 | Connecting Your Model 950 | |
| 19 | Connecting Audio Components | |
| 19 | CD Player | |
| 19 | Audio Recorder | |
| 19 | Connecting Video Components | |
| 19 | DVD Player | |
| 20 | Video Recorder | |
| 20 | Video Display | |
| 20 | Satellite Tuner or Television | |
| 20 | FM Antenna | |
| 21 | AM Antenna | |
| 21 | External Amplifier | |
| 21 | Second Zone | |
| 21 | Power Control Connections | |
| 21 | Remote Control | |
| 21 | Power Connection | |
| 22 | System Setup | |
| 22 | Navigating the Setup Menus | |
| 23 | Input Setup and Selection | |
| 24 | Speaker Configuration | |
| 24 | Speaker Placement | |
| 27 | Channel Calibration | |
| 28 | System Configuration | |
| 28 | Dolby Pro Logic II (PLII) Music Parameter | |
| 29 | Multi-zone | |
| 30 | Operation | |
| 30 | Power | |
| 30 | Selecting a Source Input | |
| 30 | Volume Control | |
| 31 | Muting the Volume | |
| 31 | Changing the Surround Mode | |
| 31 | Data Format Options | |
| 31 | Bypass Setting | |
| 32 | Tuner Operation | |
| 33 | Recording a Source | |
| 33 | Night Mode | |
| 33 | Channel Trim | |
| 34 | Theater Compensation | |
| 34 | Multichannel Source Playback | |
| 34 | Analog Bass Management | |
| 35 | Setting the Front Panel Display Brightness | |
| 35 | Setting the On Screen Display (OSD) Time Out | |
| 35 | Sleep Timer | |
| 36 | Multizone Operation | |
| 37 | Remote Control Setup and Operation | |
| 37 | Battery Installation | |
| 37 | Setup Using Preprogrammed Codes | |
| 39 | Operation | |
| 39 | Source Selection Buttons | |
| 39 | Backlighting | |
| 39 | Volume Control Punch Through | |
| 39 | Macro Buttons | |
| 40 | Example of Programming a Macro Sequence: | |
| 40 | Learning Commands from Another Remote | |
| 40 | Learning a New Command | |
| 41 | Setup Codes | |
| 44 | Care and Maintenance | |
| 44 | Cleaning | |
| 44 | When You Are Away | |
| 44 | Troubleshooting | |
| 45 | System Reset | |
| 46 | Model 950 Specifications | |
| 48 | Outlaw Audio Limited Warranty | |

Record your Model 950's serial number and date of purchase here. The serial number is found on the back panel.

Serial Number

Date of Purchase

The contents of this manual are Copyright © 2002 by Outlaw Audio, Inc., and may not be duplicated or reproduced by any means, whether physical, electronic or otherwise without prior written consent from Outlaw Audio, Inc.

Outlaw Audio and the Outlaw Audio logo are registered trademarks of Outlaw Audio, Inc.

Specifications are those in effect at the time of printing. Outlaw Audio, Inc. reserves the right to change specifications or designs at any time without notice without obligation to modify existing units.

Model 950

7.1 Channel Preamp/Processor

Thank you for purchasing the **Outlaw Audio Model 950 Preamp/Processor**. The Model 950 combines the best technologies, components, and software with a clean, user-friendly style, impeccable audio performance and leading edge capabilities, making it the perfect foundation for any music or home theater system.

In order to receive the maximum enjoyment from your Model 950, please take a few minutes to read this manual. It contains all of the necessary information to set up, connect and use your new Preamp/Processor. This important information will help you make certain that the unit is properly configured for operation with the rest of the equipment in your system. This brief investment of time will provide major dividends by making certain that your new component is properly installed and optimized for the specifics of your installation.

If you have any questions about this product, its installation or operation, please contact us via e-mail at customerservice@outlawaudio.com or via telephone at 866-OUTLAWS (688-5297).

Important Note: *The Model 950 is shipped from the factory in the following default mode:*

| | |
|----------------------|-------|
| Output Configuration | 7.1 |
| Loudspeaker Size | Small |
| All Crossovers | 100Hz |

After reading the rest of this manual and determining how your system should be set up, please refer to pages 24-26 to change these settings.

If your system will be operated in less than a 7.1 channel configuration, some DSP modes will not be available to you.

Model 950 Features

Your new Outlaw Audio Preamp/Processor is a state of the art, high performance audio device. The Model 950 provides maximum system connection flexibility with the latest surround processing technologies assuring compatibility with the widest range of source material. The Model 950 features:

- **6 Digital Inputs (2 coaxial, 4 optical)**
Each input is assignable, providing comprehensive system connectivity.
- **2 Digital Outputs (1 coaxial, 1 optical)**
For use with digital recorders or distribution systems.
- **High Bandwidth Component Video Switching**
HDTV compatible component switching for use with digital set top boxes and progressive scan DVD players.
- **5 Composite and S-Video Inputs**
High-quality video circuitry for connection to your video sources.
- **9 Analog Audio Inputs with Bypass Capability**
All analog audio inputs may be switched to Bypass mode for pure analog sound, or used with the latest surround processing algorithms.
- **Video Output Conversion**
Video inputs are automatically converted from composite to S-Video or vice versa when using these outputs.
- **High performance AM/FM Stereo tuner with 32 presets**
- **Audiophile quality preamplifier stages**
Provide maximum performance for critical music listening.
- **Dolby Digital® and Dolby Digital EX® Decoding***
Dolby Digital decoding delivers 5.1 discrete channels from DVD, satellite, cable and HDTV sources, while the latest Dolby Digital EX process adds additional rear surround information for the ultimate home theater experience.
- **Dolby Pro Logic® II***
The latest surround technology from Dolby Laboratory delivers 5.1 channel soundfields from matrix-encoded or stereo recordings.
- **DTS®, DTS-ES® and NEO:6 Decoding****
The full suite of DTS decoding and processing is available to provide multichannel reproduction from virtually any analog source as well as DTS encoded programs.
- **Cirrus Extra Surround®**
The Model 950 is the first surround product to offer Cirrus Extra Surround to provide realistic 6.1 or 7.1 sound from digital and analog sources.
- **5.1 Multichannel analog inputs**
Connect 5.1-channel outputs from a DVD-A or SACD multi-channel player or other multi-channel audio formats to these inputs.

* Manufactured under license from Dolby Laboratories.

**Manufactured under license from Digital Theater Systems, Inc. US Pat. No.5,451,942 and other worldwide patents issues and pending.

“Dolby,” “Pro Logic” and the double-D symbol are trademarks of Dolby Laboratories.

©1992-1997 Dolby Laboratories, Inc. All rights reserved.

“DTS” and “DTS Digital Surround” are trademarks of Digital Theater Systems, Inc.

© 1996 Digital Theater Systems, Inc. All rights reserved.

“Extra Surround” is a trademark of Cirrus Logic Inc.

■ Complete Multiroom System

When properly connected, a second source may be sent to a remote room, complete with remote volume control, source selection and tuner control. A trigger for the second zone allows a second amplifier to turn on and off independently of the main room. This system may also be used to record an input source that is different from the one being used in the main room.

■ 2 Low voltage triggers

One trigger provides automatic turn on/off of compatible power amplifiers such as the Outlaw Model 770/755/750 or relay-controlled products such as projection screens, blinds and lighting systems. A separate trigger provides turn on/off control for an amplifier used with the multiroom system.

Unpacking

The carton and packing materials used in shipping your new Preamp/Processor were specially designed to cushion it from the shocks and vibration of shipping. We strongly suggest that you save the carton and packing materials to use if you move, or if the unit ever needs to be shipped back to us for any reason.

To minimize the size of the carton in storage, you may wish to flatten it by carefully opening the top and bottom flaps and folding the carton flat. Other cardboard inserts may be stored in the same manner. Packing materials that cannot be collapsed should be saved along with the carton in a plastic bag.

Although not particularly heavy, the 950 has many front mounted controls and rear panel connectors, so be careful when lifting it so as not to cause damage.

Accessories

After unpacking the Model 950, please check that the following accessories are in the box:

- Remote Control with Batteries
- AC Power Cord
- FM Antenna
- AM Loop Antenna
- Owner's Manual

If for any reason any of the above is missing from your shipment, please contact Outlaw Audio immediately.

Model 950 Front Panel

1 Standby power button (see page 22, 30)

When the main POWER switch on the rear panel is in the ON position, pressing this button turns the unit on. The yellow STANDBY/MUTE indicator light goes out.

Pressing this button again returns the Preamp/Processor to standby mode. The STANDBY/MUTE indicator light illuminates.

In this mode of operation, the FRONT PANEL DISPLAY is turned off, control functions are disabled, and all outputs to the main zone are turned off. However, outputs to the remote zone remain active and available.

2 FM MODE button (see page 32)

Sets the FM Tuner to Mono mode. The letter "M" appears next to the Tuner Preset number in the FRONT PANEL DISPLAY. Pressing the button again returns the FM Tuner to Stereo mode.

3 TUNE buttons (see page 32)

The ∨ and ∧ buttons adjust the tuner's frequency down or up when Tuner is selected as the input source.

4 FM/AM button (see page 32)

Toggles between AM and FM frequency bands. Pressing this button when listening to any other source automatically changes the unit's input source to the tuner and the last station chosen.

5 FRONT PANEL DISPLAY (see page 9)

Indicates program source, DSP mode, tuner preset and/or frequency, digital input, volume level, and other preamp/processor/tuner operating information. Also displays menu selections.

6 TEST TONE button (see page 27)

Press this button to use the internal test generator to adjust the output level for each channel. As the test signal circulates among the channels press the < or > Navigation buttons to make an adjustment.

7 DIGITAL SELECT button (see page 30)

Press this button to select a digital input. Each press of the button scrolls to the next input, as shown on the FRONT PANEL DISPLAY or the ON SCREEN DISPLAY. When ANALOG is shown, the L/R analog input associated with the input in use will be used.

8 STEREO BYPASS button (see page 31)

Defeats the DSP processing section and provides an unaltered, full-bandwidth stereo signal to the Left and Right channel outputs on the rear panel. However, the subwoofer DSP crossover remains active and bass frequencies are available at the subwoofer output should you wish to augment your front LR speaker's low frequency performance. The word BYPASS appears in the FRONT PANEL DISPLAY. Pressing the button again returns the unit to the previously selected DSP mode.

9 TRIM button (see page 33)

Press this button to adjust the output of an individual channel above or below the master volume level setting from -15dB to +10dB. Press the < or > Navigation buttons to adjust the level for the channel indicated in the FRONT PANEL DISPLAY or the ON SCREEN DISPLAY and then press the button again to select another channel.

Model 950 Front Panel

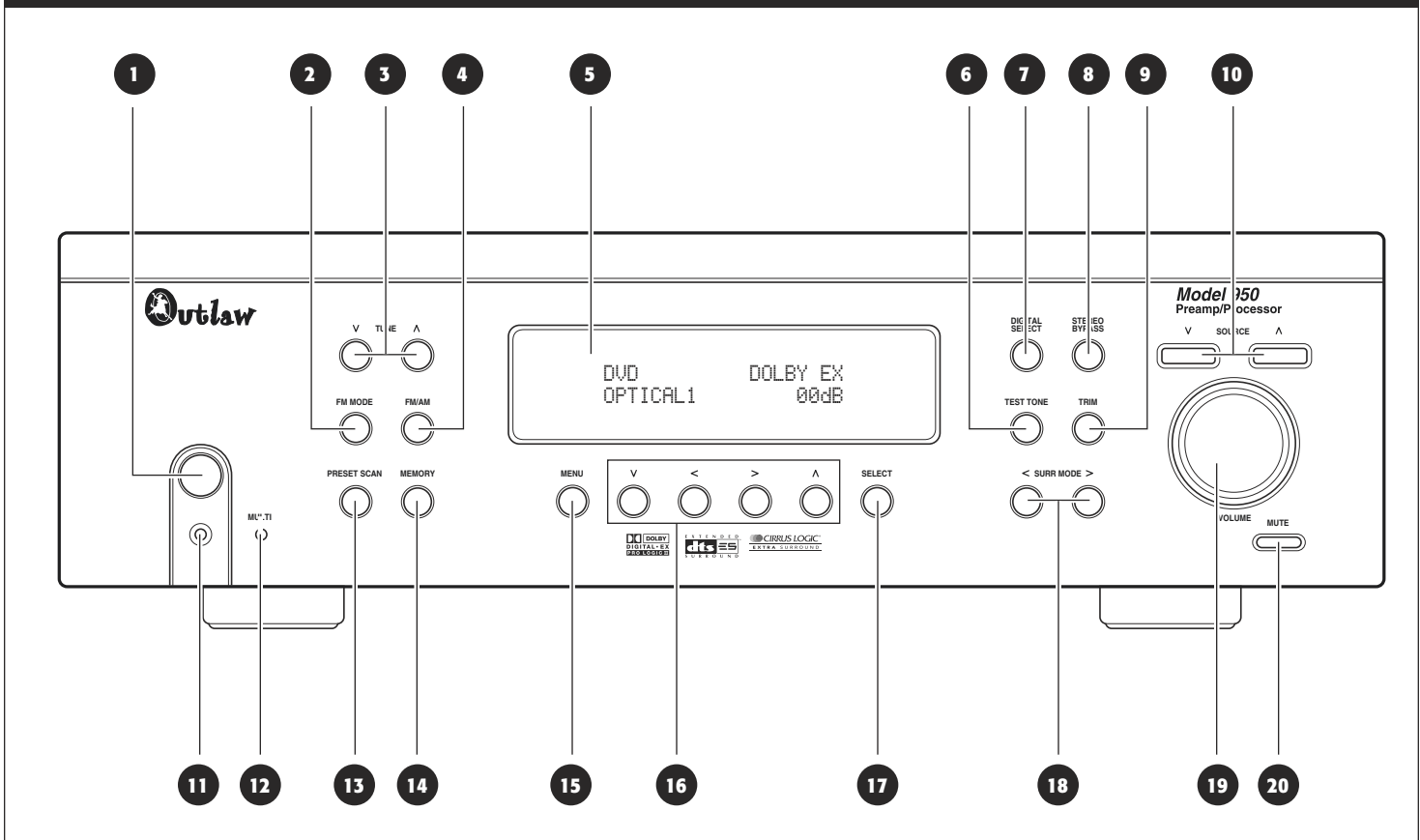

10 SOURCE buttons (see page 30)

Press these buttons to select an input source.

11 On/Standby/Mute indicator (see page 22, 30)

Lights to indicate when the unit is in Standby mode and goes out when the preamp/processor is active. Also blinks to indicate when the main volume is muted.

12 MULTI indicator LED (see page 29, 36)

Lights to indicate that the second zone (Zone 2) is active. Note that this light will remain lit when the other indicators are off, as long as the second zone is active.

13 PRESET SCAN button (see page 32)

Pressing this button scans the AM or FM stations preset in the tuner's memory. Pressing it again stops the scan at the preset indicated in the FRONT PANEL DISPLAY. The unit's input source automatically changes to Tuner when this button is pressed.

14 MEMORY button (see page 32)

Pressing this button when FM or AM is selected as the input source memorizes the current station frequency into one of the presets. You can preset up to 32 stations.

15 MENU button (see page 22)

Displays menu options on the FRONT PANEL DISPLAY and the On Screen Display (OSD). Press the button again to exit the Menu mode.

16 Navigation buttons (see page 22)

When in Menu mode, use these buttons to navigate through menu options displayed on the FRONT PANEL DISPLAY or the On Screen Display (OSD). These buttons are also used to change options or settings with some of the front panel controls.

17 SELECT button (see page 22)

When in Menu mode, selects menu options displayed on the FRONT PANEL DISPLAY or the On Screen Display (OSD).

18 SURR MODE buttons (see page 31)

Press these buttons to select from the various surround modes provided by the Model 950. Mode availability depends on setup configuration and input source.

19 VOLUME control (see page 30)

Adjusts the volume level for the main zone only. Remote zone (Zone 2) is not affected by this control.

20 MUTE button (see page 31)

Mutes the volume of the Preamp/Processor. The STANDBY/MUTE indicator blinks. Pressing the button again returns the unit to the previous volume setting. The STANDBY/MUTE indicator goes out.

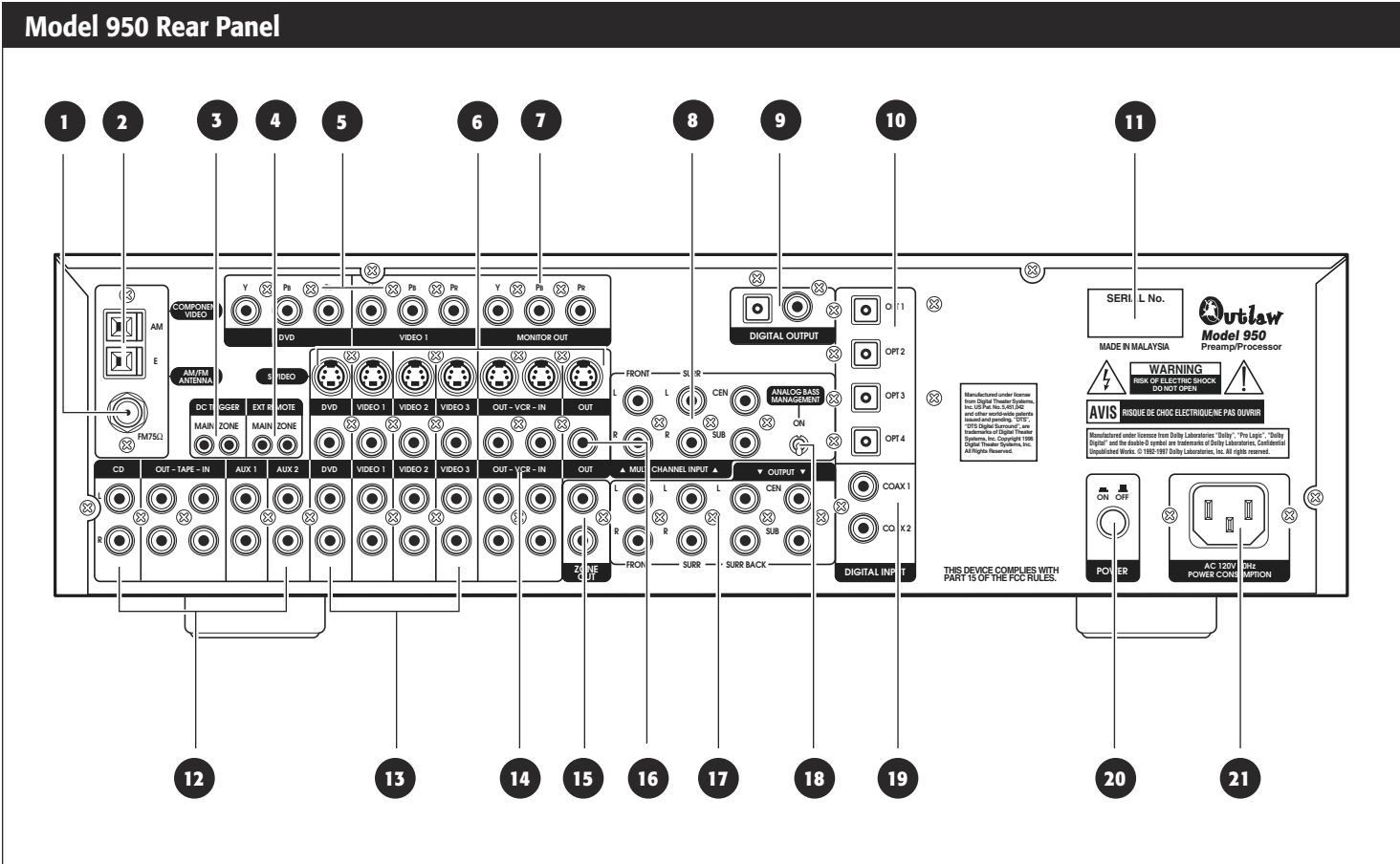

Model 950 Rear Panel

Below is a brief explanation of the connections and switches found on the rear panel of the Model 950 Preamp/Processor. Before connecting any audio or video components to the unit, familiarize yourself with the type and location of connectors available.

- 1 FM Antenna terminal** (see page 20)
 Use to connect the supplied FM antenna or an external 75 Ω antenna.
- 2 AM Antenna terminals** (see page 20)
 Connect the supplied AM loop antenna or an external AM antenna to these terminals.
- 3 Remote Trigger jacks** (see page 21)
 Use the MAIN and ZONE DC TRIGGER jacks to control external devices (such as a power amplifier) with a 3-32 VDC trigger input. The device connected to the MAIN jack will be activated when the 950 is turned on and should be used for connections to power amplifiers for the main room speakers. The device connected to the ZONE trigger will only be activated when the Multi-zone system is turned on. Connect it to the amplifier used to power the speakers in the second zone.
- 4 Remote Control jacks** (see page 21)
 Use the MAIN and ZONE EXT REMOTE jacks to connect external IR sensors to the Model 950. When the unit is installed behind doors or where it is not otherwise visible to the remote, connect an optional, external

sensor to the MAIN jack. To control the 950's Multiroom system from a remote location, connect an optional remote sensor in the second room to the ZONE jack

- 5 Component Video Input jacks** (see page 19-20)
 Use these two sets of jacks to connect devices with component video outputs such as a DVD player or HDTV tuner.
- 6 S-Video jacks** (see page 19-20)
 Connect the S-Video output of sources to the appropriate input jacks. Connect the VCR-OUT jack to the input of a VCR or other recorder and connect the OUT jack to an S-Video input on your video display device.
- 7 Component Video Output jacks** (see page 19-20)
 Use these jacks to supply component video output to an external monitor that accepts component video signals.
- 8 5.1 Channel Input jacks** (see page 21)
 Connect the multichannel signal from the analog audio outputs of a device such as a DVD, DVD-A or SACD to these jacks.
- 9 Digital Outputs** (see page 20)
 Use the coaxial and optical digital outputs to connect the preamp/processor to a device such as CD recorder, DAT recorder, or other similar device that accepts a digital audio input.

10 Optical Digital Inputs (see page 19-20)

Use these inputs to connect the optical digital audio signal output from such digital devices as CD, DVD or LD players. These inputs are fully assignable.

11 Product Serial Number

Write this number in the space provide on page 4 for future reference.

12 Audio Source Input jacks (see page 19-20)

Use these inputs for connection to analog audio sources such as a CD player. One in/out tape loop is provided for connection to an audio recorder.

13 Video Source Input jacks (see page 19-20)

Use these inputs for connection to the composite video and analog audio output from sources such as a DVD or LD player, satellite receiver, cable box, PVR or other video source. Note that when the Component Video inputs are used, connect the analog audio outputs of the source to the DVD or Video 1 jacks, as appropriate.

14 VCR jacks (see page 20)

Use these input and output jacks to connect a VCR to the Model 950.

15 Multi-zone Output jacks (see page 21)

Use these jacks to supply the analog stereo audio output to an optional audio amplifier used to power the speakers in the remote zone.

16 Monitor Output jack (see page 20)

Connect this output to the composite video input of your monitor or other video display device.

17 Amplifier Output jacks (see page 21)

Use the seven audio channel output jacks to connect the Model 950 to an external power amplifier. The eighth jack supplies the output to a powered subwoofer or external subwoofer amplifier.

18 5.1 Input Bass Management Control (see page 34)

Setting this switch in the ON position activates an 80Hz High Pass Filter for the 5.1 channel direct input, except the subwoofer. The bass signals from the 5 satellite channels are summed and sent on to the subwoofer output at all times. Setting the switch in the down position turns off the High Pass Filter and sends full-range audio to all channels. This Bass Management Control is totally separate from the DSP Bass Management set up using the front panel or remote control.

19 Coaxial Digital Input jacks (see page 19-20)

Use these inputs to connect the coaxial digital audio signal output from such digital devices as CD, DVD or LD players. These inputs are fully assignable.

20 Main Power switch (see page 22)

Turns the current to the Model 950 On or Off. Setting this button to the On position (pushed in) supplies power to the unit, enabling use of the Standby Power button on the front panel. When the Main Power switch is in the Off position, current is cut off to the unit>

21 AC Input (see page 21)

Use to connect the supplied AC power cord (see Precautions on page 2).

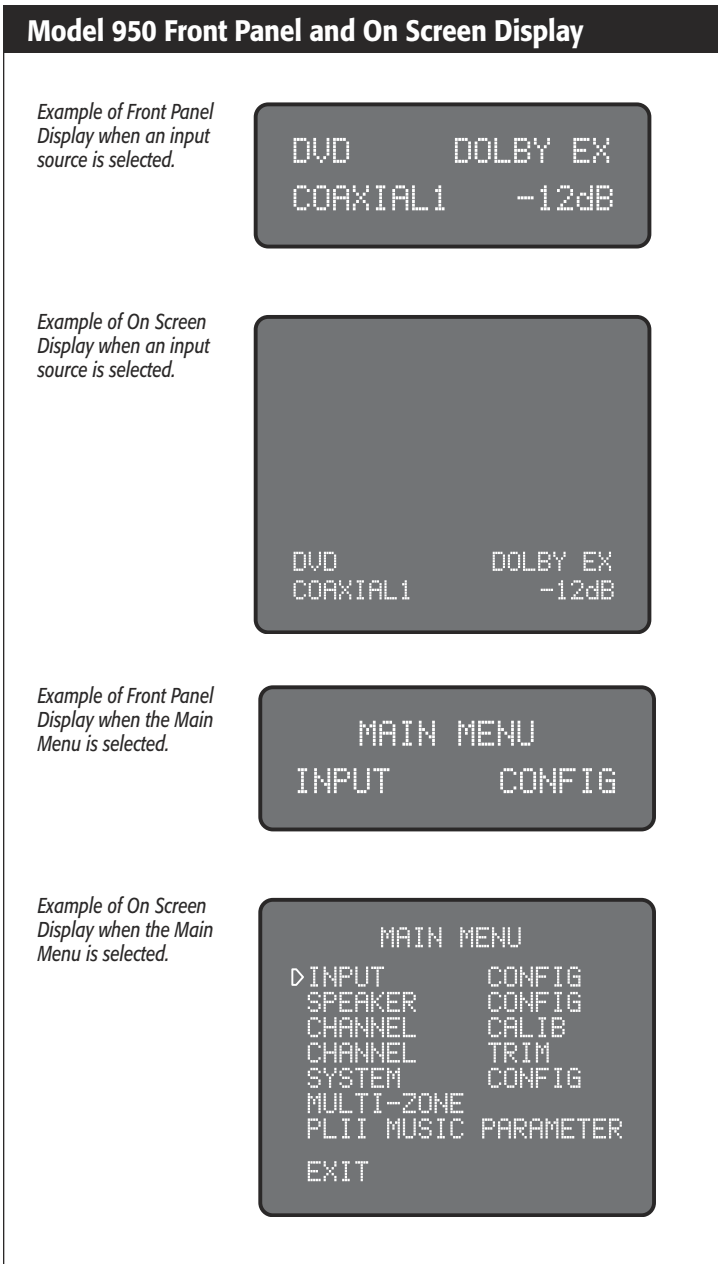

Front Panel and On Screen Display (OSD)

The FRONT PANEL DISPLAY and ON SCREEN DISPLAY (OSD) provide visual feedback of the current settings, surround modes and configuration menus of the unit. Information is constantly displayed at the front panel whenever the Model 950 is turned on. To use the OSD, the unit must be connected to your display device using either the composite or S-Video MONITOR OUT jacks. The OSD will not operate through the component video outputs of the 950. However, the OSD output will appear at both the composite and S-Video jacks regardless of the type of source in use.

The information presented on the front panel is identical to that shown on your TV monitor, allowing you to perform speaker settings, set up your input sources, set the listening modes, and much more.

Model 950 Remote Control

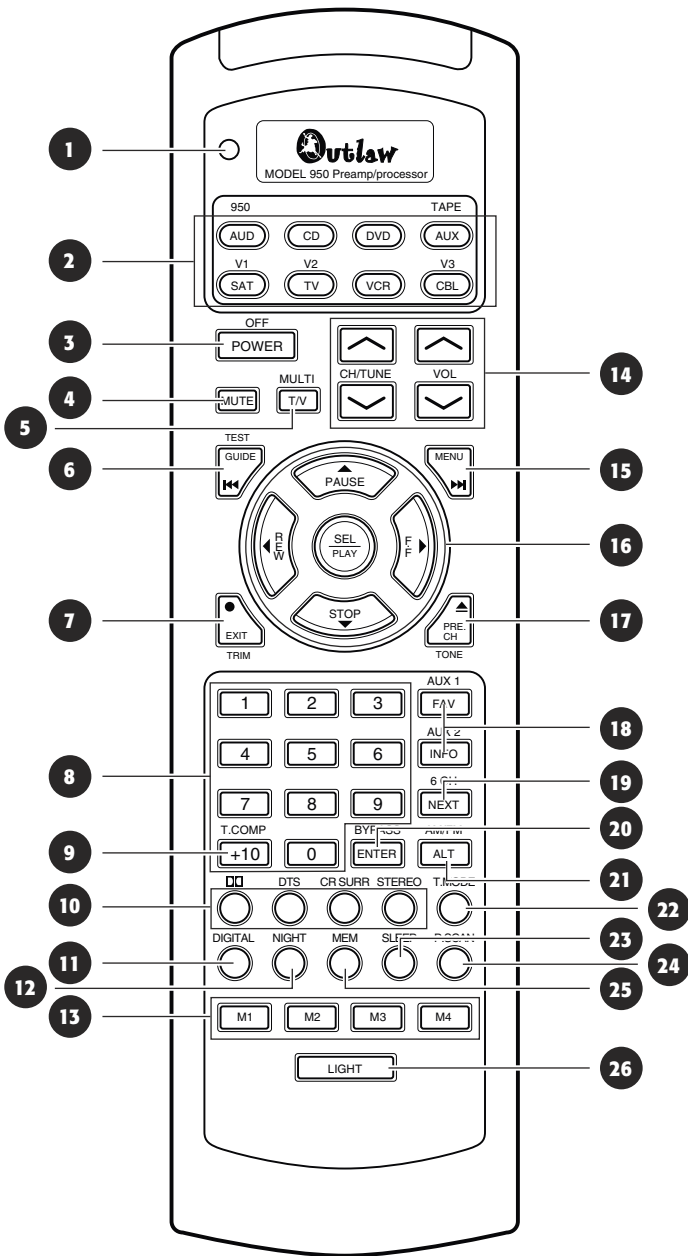

Remote Control

The Model 950 Universal Learning Remote Control duplicates every function available from front panel of the preamp/processor and more. It is designed to access all the configuration and operation menus of the 950. These are displayed on the FRONT PANEL DISPLAY of the Model 950, as well as the ON SCREEN DISPLAY (OSD) The Remote Control contains an extensive library of IR codes and may be programmed to operate a wide range of audio and video components. Additionally, you can teach the remote to control other audio/video units not included in the unit's built-in memory by entering their particular device codes (see page 39).

Many of the buttons on the Remote Control serve several functions, depending on the source device being controlled. The list below describes each buttons main functions. For a complete description of their use, please refer to the section titled "Remote Control Setup and Operation."

1 Status LED Indicator (see page 37)

Indicates when the remote control is in Programming or Learning mode and flashes to indicate success or failure of these functions.

2 Source Selection buttons (see page 30)

When the Model 950 is in Standby mode, pressing one of these buttons turns the unit on and selects that source as the current input.

If the Model 950 is already on, pressing one of these buttons selects that source as the new input.

In both cases, once properly programmed, the remote control operates the source device selected.

The AUD button tells the Remote to control the Model 950.

The Source button selected will light whenever you push one of the Remote's function buttons to indicate that you have sent a command to that component. If the command you have pressed is one that typically is not available on that type of unit (i.e. P SCAN on a CD player) the source button will not light even though you have pressed that button.

3 POWER button (see page 27, 30)

Returns the Model 950 to standby mode when the unit is on.

4 MUTE button (see page 31)

Mutes the main volume of the Model 950. Does not mute the second zone.

5 Multi-zone button (see page 36)

Press the MULTI button to call up and cycle through the Multi-zone menu options on the FRONT PANEL DISPLAY and the OSD, if active.

6 TEST button (see page 27)

Outputs an audio test tone for calibrating and setting speaker levels. Pressing the button again restores the audio output from the previously selected input source.

7 TRIM button (see page 33)

Activates the Channel Trim function. Pressing the button cycles through all the channels individually for trim adjustment 10dB above or 15dB below the master volume setting, in 1dB steps.

- 8 Numeric Keypad buttons** (see page 32)
Use these buttons for control functions requiring you to enter numbers. For numerals over 10, press the 10+ button for every multiple of ten, followed by a second digit.
- 9 Theater Compensation button** (see page 34)
The T.COMP button toggles Theater Compensation processing on and off.
- 10 Surround/Data Format buttons** (see page 31)
Press the **DQ**, DTS, CR SURR or STEREO button once to select a surround processing format .

Press the same button again to cycle through the various processing modes available for the selected format.

Pressing and holding the button for five (5) seconds calls up the Data Format menu.
- 11 DIGITAL button** (see page 30)
Cycles between the six digital inputs and the analog input on the Model 950. The selected input is shown on the FRONT PANEL DISPLAY and the OSD, if active.
- 12 NIGHT button** (see page 33)
Cycles through the various Night dynamic range compression modes.
- 13 Macro Control buttons** (see page 39)
The M1, M2, M3 and M4 buttons are used to play back macros, which are preprogrammed sequences of IR commands that you have entered in the remote.
- 14 Tuning and Volume buttons** (see page 30, 32, 39)
Use the ∇ and \wedge CH/TUNE buttons to adjust the Model 950 tuner's frequency down or up when AUD is selected as the input source. These buttons also operate the tuner or change channels of other devices that are selected as the current source.

Use the ∇ and \wedge VOL buttons to adjust the volume of the Model 950 from -80dB to +10dB. These buttons also operate the volume control of other devices that are selected as the current source.
- 15 MENU button** (see page 22)
Calls up the Main Menu on the FRONT PANEL DISPLAY and the OSD, if active.
- 16 Navigation and Select buttons** (see page 22)
Use the four Navigation buttons to move through menu options shown on the FRONT PANEL DISPLAY or OSD. Use the SEL button to confirm selections made in menus.
- 17 TONE button** (see page 23)
Press this button to select either the Treble or Bass for adjustment. Once the desired parameter is selected, use the < or > navigation buttons to change the setting. The Treble and Bass can be adjusted ± 6 dB. Settings are shown on the on the FRONT PANEL DISPLAY and the OSD, if active.
- 18 Auxiliary Input buttons** (see page 30)
Use the AUX 1 and 2 buttons to select the device connected to one of the two AUX inputs as the active source.
- 19 6 Channel Direct button** (see page 34)
Pressing the 6 CH button selects as the source the analog signal from the Multi Channel inputs (5 channels plus subwoofer) on the Model 950, as well as activating the dedicated Bass Management selected by the rear panel switch. Pressing the button again returns the unit to the previously selected source.
- 20 BYPASS button** (see page 31)
Activates Stereo Bypass mode, sending the signal from the analog input in use directly to the volume control, bypassing all digital processing. Pressing the button again returns the unit to the previously selected mode.
- 21 AM/FM button** (see page 32)
Press this button to select the 950's tuner as the input source, or to switch between the AM and FM bands when the tuner is active. Pressing this button when the 950 is in Standby mode will also turn the unit on.
- 22 Tuner Mode button** (see page 32)
Press the T.MODE button to switch the FM tuner between Mono and Stereo.
- 23 SLEEP button** (see page 35)
Sets the 950's built-in sleep function timer.
- 24 Preset Scan button** (see page 32)
Pressing this button scans the AM or FM stations preset in the tuner's memory. Pressing it again stops the scan at the preset indicated in the FRONT PANEL DISPLAY.
- 25 Memory button** (see page 32)
Press and hold the MEM button to store an AM or FM station into a preset location. Once the FRONT PANEL DISPLAY begins to flash Memory 01, enter the desired preset number using the numeric keypad on the remote.
- 26 Light**
Illuminates the Remote Control buttons for 7 seconds.

Surround Format Information

The Outlaw Audio Model 950 employs the latest technology developed in conjunction with Cirrus Logic®, providing one of the most extensive arrays of surround decoding and processing currently available. You can choose from Dolby Pro Logic® II, Dolby Digital® 5.1, Dolby Digital EX®, DTS®, DTS-ES® Discrete, DTS-ES® Matrix, DTS NEO:6® and Cirrus Extra Surround®. Within each mode, the 950 also offers a wide range of additional processing options. This means you can precisely match a surround mode to your program material, loudspeaker setup and personal taste. In addition, the Model 950 uses Cirrus Logic's Triple Crossover® and Precision Bass Management® features to provide maximum flexibility when setting up your audio surround system (see "System Setup" on page 22 for further details).

The table below lists the surround processing choices available within each mode. Depending on the selected source (analog or digital) and your loudspeaker configuration, certain processing options may not appear or operate.

| D | A | Display Text | Name | Description |
|---|---|--------------|--|--|
| ● | ● | PLII-C | Pro Logic II Cinema | Use for surround enhanced film soundtrack playback from any 2-channel source such as VCR |
| ● | ● | PLII-M | Pro Logic II Music | For surround enhanced playback of 2 channel (stereo) music |
| ● | ● | DOLBY PL | Pro Logic Emulation | Equivalent to original Pro Logic surround processing with mono surround |
| ● | ● | PLIIC CR | Pro Logic II Cinema w/ Cirrus Ex Surr | Adds Cirrus Extra Surround processing of rear channels to Pro Logic II Cinema |
| ● | ● | PLIIM CR | Pro Logic II Music w/Cirrus Ex Surr | Adds Cirrus Extra Surround decoding of rear channels to Pro Logic II Music |
| ● | ● | NEO: 6C | DTS NEO:6 Cinema | Creates 6.1 channel surround from any movie-based source |
| ● | ● | NEO: 6M | DTS NEO:6 Music | Creates 6.1 channel surround from any music-based source |
| ● | ● | 5 STEREO | 5 Channel Stereo | Creates a 5-channel program (L/C/R/LS/RS) from any stereo source |
| ● | ● | 7 STEREO | 7 Channel Stereo | Creates a 7-channel program (L/C/R/LS/RS/LSB/LSR) from any stereo source |
| ● | | DOLBY D | Dolby Digital | 5.1 channel processing for all Dolby Digital encoded sources |
| ● | | DOLBY EX | Dolby Digital Surround EX | 6.1 channel processing for soundtracks encoded with Dolby EX |
| ● | | DD CR-C | Dolby Digital w/ Cirrus Ex Surr Cinema | Adds Cirrus Extra Surround post processing to Dolby Digital. Creates a rear surround channel |
| ● | | DD CR-M | Dolby Digital w/ Cirrus Ex Surr Music | Adds Cirrus Extra Surround post processing to Dolby Digital. Creates a rear surround channel |
| ● | | DTS | DTS | 5.1 channel processing for all DTS encoded sources |
| ● | | DTS-ES | DTS Extended Surround | 6.1 channel processing for all sources encoded with DTS-ES |

Dolby Digital

This digital audio format provides 5.1-channel surround sound. Dolby Digital source material includes DVDs, LaserDiscs, HDTV broadcasts, some satellite delivered programming, and the output of some digital cable set top boxes.

Dolby Digital Surround EX

This processing mode is a joint development of Dolby Laboratories and the THX division of LucasFilm, Ltd. Film soundtracks encoded with Dolby Digital Surround EX technology contain an extra channel, added to the soundtrack during mixing, called Surround Back, which places audio behind the listener in addition to the existing front left, front center, front right, surround left, surround right, and subwoofer channels. This additional channel provides more detailed imaging behind the listener creating more depth, spacious ambience and sound localization than before.

A list of movies created using Dolby Digital Surround EX can be found on the Dolby web site at www.dolby.com

NOTE: Surround EX mode can also be engaged during the playback of 5.1 channel material that is not Dolby Digital Surround EX or DTS-ES Matrix or Discrete encoded. When used this way, signals from the left and right surrounds are used to synthesize the surround back channel. Results using this method will vary depending on the source material.

Dolby Pro Logic II

Dolby Pro Logic II is a substantial enhancement to the original Pro-Logic process. In addition to full-bandwidth surrounds, Pro Logic II provides three unique user adjustable processing options: Panorama; Dimension; and Center Width. Used primarily in Pro Logic II Music mode, these choices are also available when employing the Cirrus Extra Surround processing option.

Panorama provides an extension of the front stereo image to the surround channels creating an enveloping, wraparound effect.

Dimension enables adjustment of the surround image between the front and rear of your room. Certain types of music benefit from smoother overall balance and a more natural sounding image.

Center Width provides variable adjustment of the center channel image and location, to create a more seamless front soundstage as well as control of the sense of 'width' across the L/C/R loudspeaker array. A phantom center image can also be created from just the left and right front speakers.

DTS

This compressed digital data format is similar to Dolby Digital, but uses a higher sampling rate. DTS also provides a maximum of 5.1 channel surround channels and is available on compact disc, DVD and LaserDiscs. Audio-only DTS discs may be used with any CD, LD or DVD player with a digital audio output, but DVD discs with DTS audio must be used on players with the "DTS Digital Out" logo.

DTS-ES

DTS-ES is an extension of the original DTS format that adds an additional sixth, or center surround, channel to a soundtrack. DTS-ES Matrix titles provide the sixth channel by a matrix process, while DTS-ES Discrete media deliver a true discrete center surround channel. Both DTS-ES formats are backwards

compatible with the original DTS process, and will deliver a 5.1 channel output when no center or back surround speakers are available.

The Model 950 will automatically sense the availability of either DTS-ES format and automatically switch the processing mode when required.

DTS NEO:6

This processing mode can create up to 6 full bandwidth channels from any matrix-encoded 2-channel source. Additionally, this mode can produce the rear surround information from a 5.1 source.

In Music Mode it can expand stereo music material, such as from a CD, into a multichannel surround experience.

Cirrus Extra Surround

This unique decoding algorithm creates 6.1 or 7.1 output from either matrix-encoded or discrete audio signals. When Cirrus Extra Surround is selected using either the remote or the front panel controls the display will show the primary selected mode plus a CR identifier—such as PL2C-CR. To determine what mode is best for any specific program material it will be necessary to experiment to decide what suits your systems and personal taste best.

Stereo

This mode provides conventional 2 channel signals to the left and right front speakers only.

Additional Information

More detailed information about the various surround processing options contained in the Model 950 can be found on the following websites:

www.dolby.com
www.dtsonline.com
www.cirrus.com

Connecting Your Model 950

Before proceeding, please observe the following precautions when connecting devices to your new Model 950.

- Do not plug the power cord into your Model 950 until all other connections have been made.
- Always refer to the instructions that came with the component that you are connecting for specific procedures, warnings and options.
- For all analog connections, the red input jacks (R) are used for the right channel, white input jacks (L) are used for the left channel, and yellow input jacks (V) are used for the composite video connection.
- Make sure to insert all plugs and connectors securely. Improper connections can result in noise, poor performance, or damage to the equipment.
- Do not bundle audio/video connection cables with power cords and speaker cables. Doing so may adversely affect the picture and sound quality. For example, run all the power cords down one side of the cabinet, all the signal cords down the other side, and the speaker wires down the center.
- When connecting devices to the digital inputs and outputs, you may also consider hooking up the analog connections to and from the components to insure that all signals can be employed by the preamp/processor.
- When using the optical input or output jacks, remove the protective cap and keep it in a safe place. When these jacks are not in use the protective cap should be replaced.
- When using an optical input or output jack, always use a high-quality optical fiber cable.

IMPORTANT NOTE: *We strongly recommend that before you connect any loudspeakers to your amplifiers, you complete all needed connections and set up procedures to your Model 950 as outlined below. This will reduce the chance that a misconnection or other error will produce audio output that might damage your speakers or other components.*

Given the wide variety of components that can be connected to your Model 950, there are numerous ways in which your system can be assembled. To help you with this task, we have provided a chart (page 18) to record the components connected to your unit, as well as which type of input (analog, coaxial, S-Video, etc.) is used. Keep this chart for future reference.

There are many possible ways to connect a particular device. Use the diagrams on the following pages as a guideline. The information in this section contains some of the more common situations you might encounter in your system. Always consult the owner's manual that came with the component you are connecting for more information on the source component's connections.

Connecting Audio Equipment to the Model 950

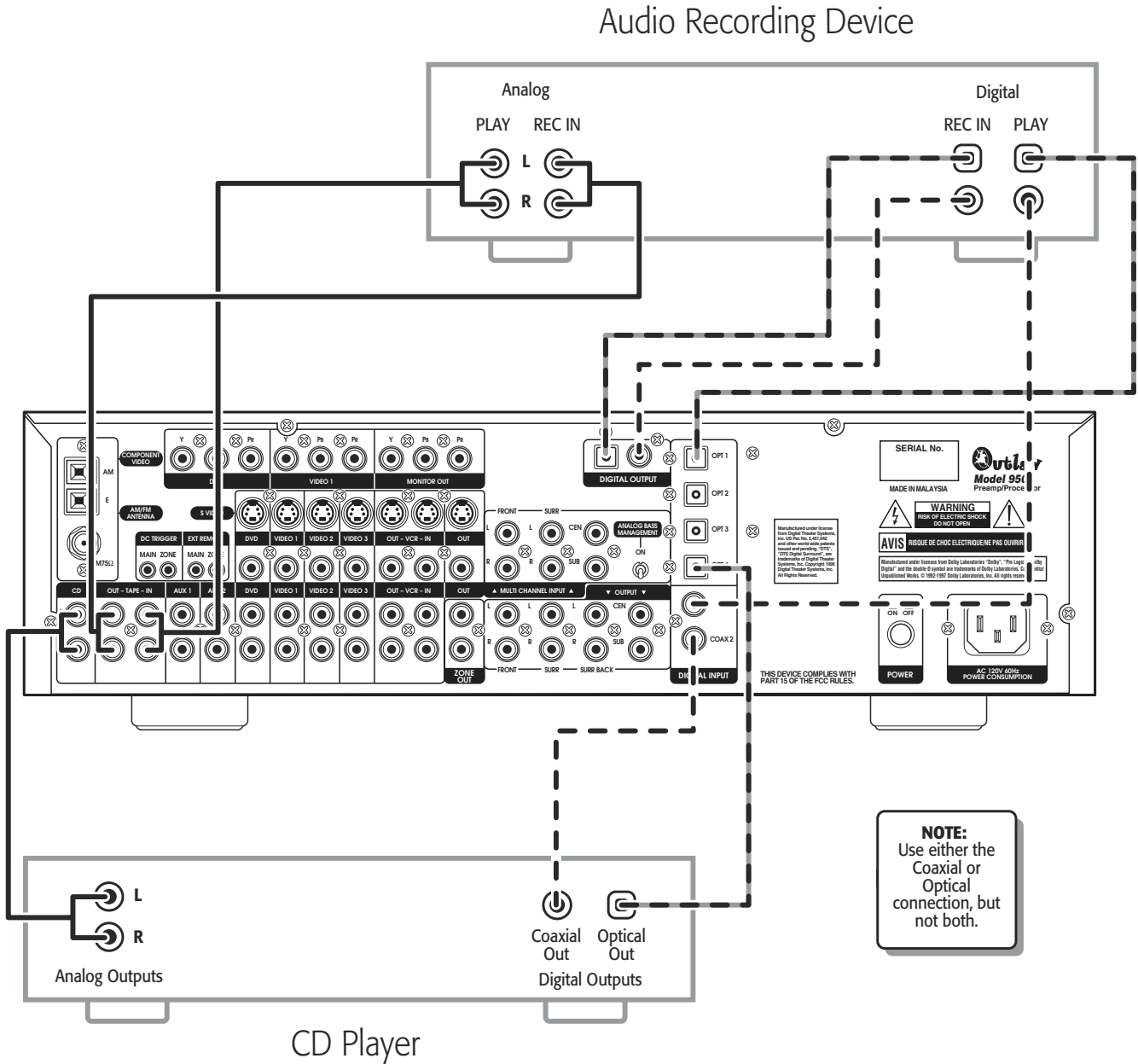

Connecting Video Equipment to the Model 950

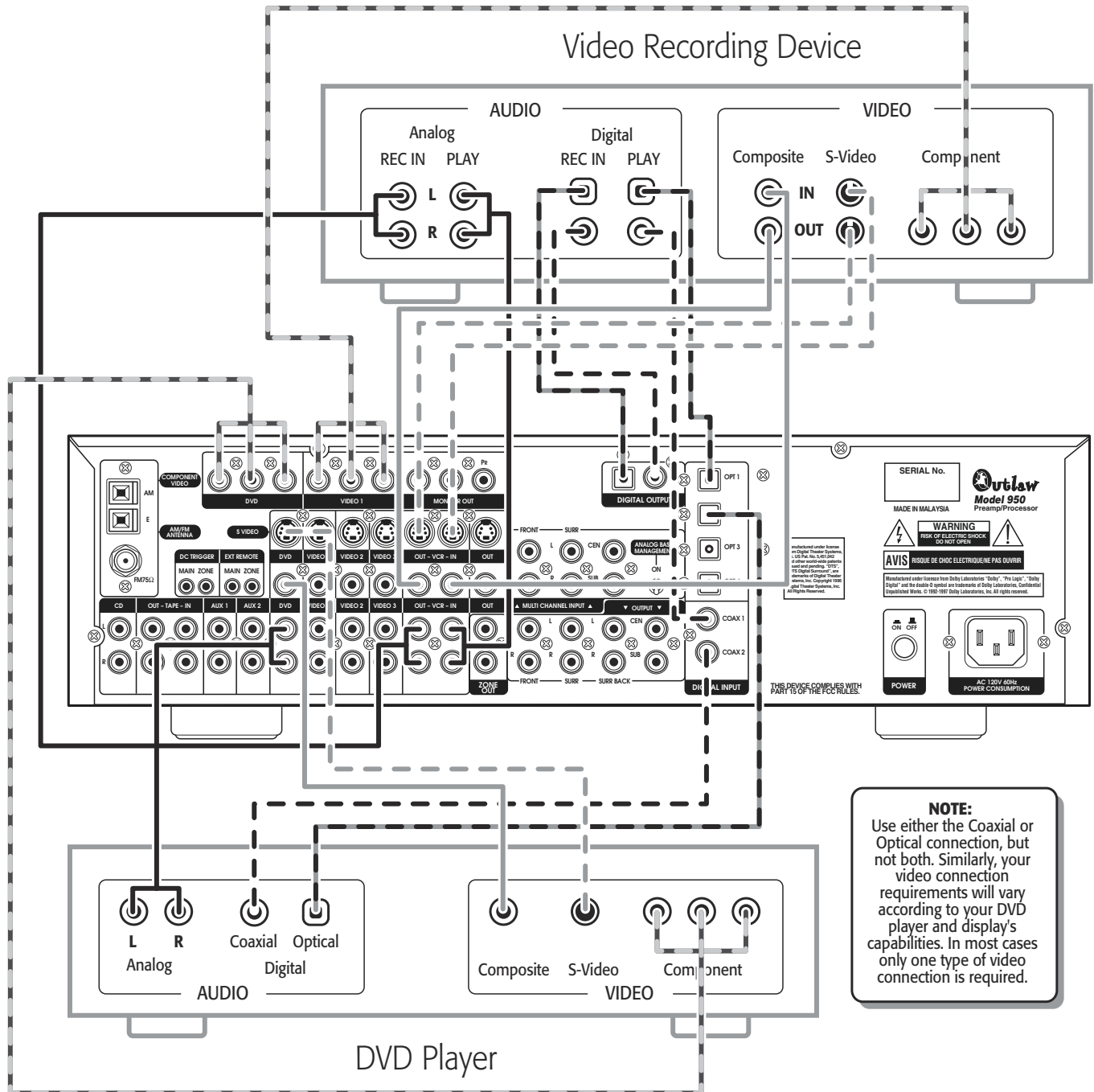

Connecting an External Amplifier to the Model 950

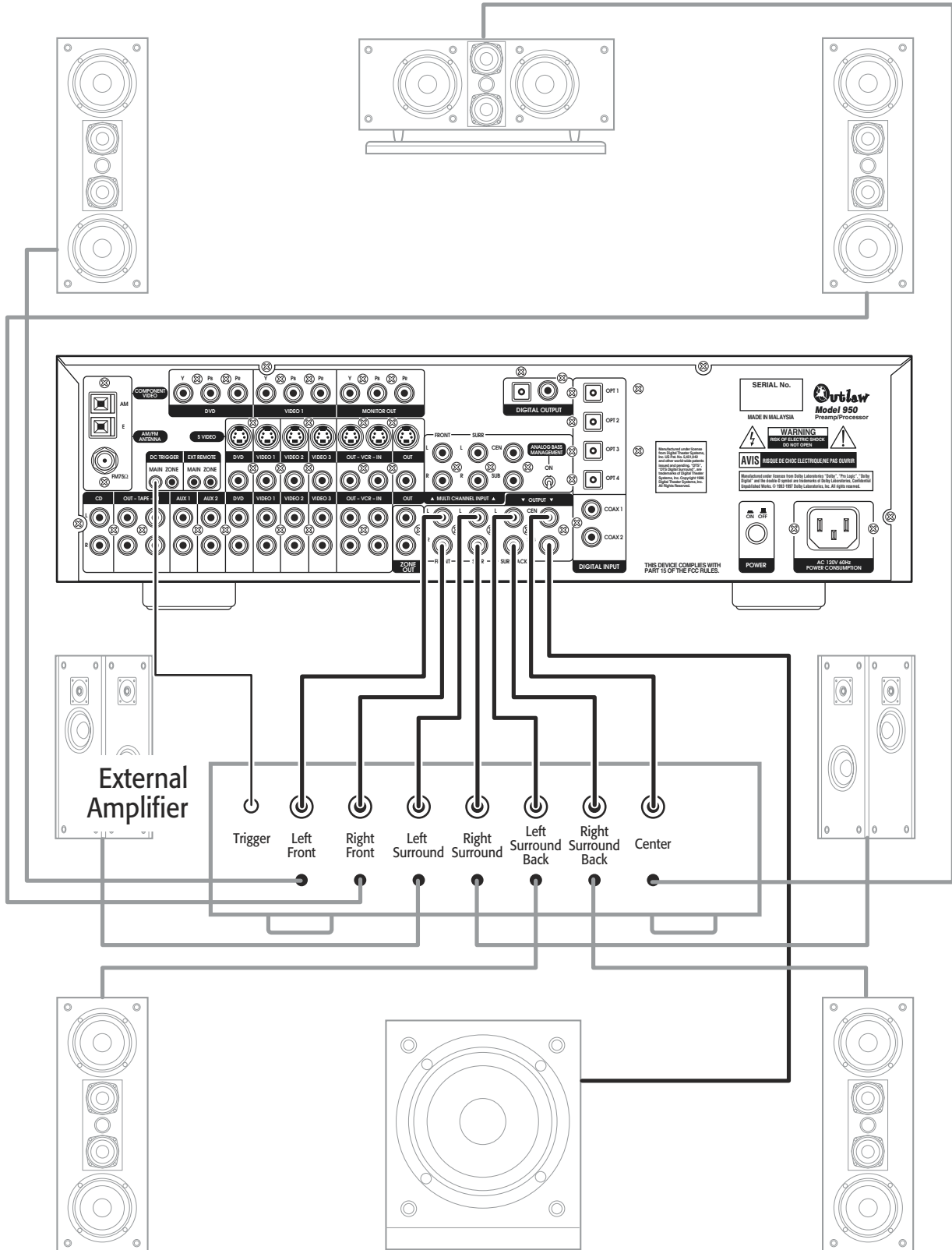

Connecting the Model 950 to an External Amplifier in a Second Zone

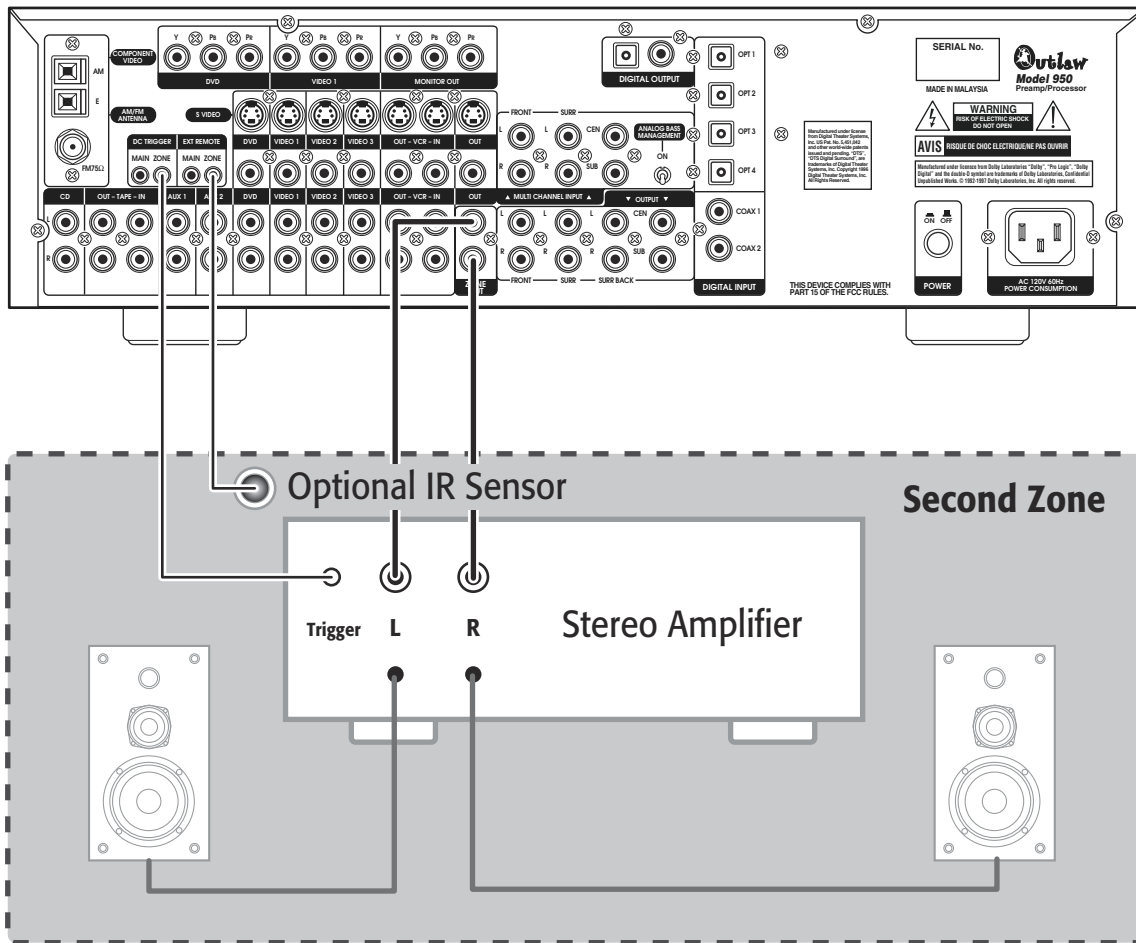

Connection Record Chart

| DVD | | VIDEO 1 | | VIDEO 2 | | VIDEO 3 | | VCR | |
|-----------------|--------------------------|-----------------|--------------------------|-----------------|--------------------------|-----------------|--------------------------|---|--------------------------|
| Device _____ | | Device _____ | | Device _____ | | Device _____ | | Device _____ | |
| Surr Mode _____ | | Surr Mode _____ | | Surr Mode _____ | | Surr Mode _____ | | Surr Mode _____ | |
| Video | | Video | | Video | | Video | | Video | |
| Composite | <input type="checkbox"/> | Composite | <input type="checkbox"/> | Composite | <input type="checkbox"/> | Composite | <input type="checkbox"/> | Composite | <input type="checkbox"/> |
| S-Video | <input type="checkbox"/> | S-Video | <input type="checkbox"/> | S-Video | <input type="checkbox"/> | S-Video | <input type="checkbox"/> | S-Video | <input type="checkbox"/> |
| Component | <input type="checkbox"/> | Component | <input type="checkbox"/> | Component | <input type="checkbox"/> | Component | <input type="checkbox"/> | Component | <input type="checkbox"/> |
| Audio | | Audio | | Audio | | Audio | | Audio | |
| Analog | <input type="checkbox"/> | Analog | <input type="checkbox"/> | Analog | <input type="checkbox"/> | Analog | <input type="checkbox"/> | Analog | <input type="checkbox"/> |
| Coaxial 1 | <input type="checkbox"/> | Coaxial 1 | <input type="checkbox"/> | Coaxial 1 | <input type="checkbox"/> | Coaxial 1 | <input type="checkbox"/> | Coaxial 1 | <input type="checkbox"/> |
| Coaxial 2 | <input type="checkbox"/> | Coaxial 2 | <input type="checkbox"/> | Coaxial 2 | <input type="checkbox"/> | Coaxial 2 | <input type="checkbox"/> | Coaxial 2 | <input type="checkbox"/> |
| Optical 1 | <input type="checkbox"/> | Optical 1 | <input type="checkbox"/> | Optical 1 | <input type="checkbox"/> | Optical 1 | <input type="checkbox"/> | Optical 1 | <input type="checkbox"/> |
| Optical 2 | <input type="checkbox"/> | Optical 2 | <input type="checkbox"/> | Optical 2 | <input type="checkbox"/> | Optical 2 | <input type="checkbox"/> | Optical 2 | <input type="checkbox"/> |
| Optical 3 | <input type="checkbox"/> | Optical 3 | <input type="checkbox"/> | Optical 3 | <input type="checkbox"/> | Optical 3 | <input type="checkbox"/> | Optical 3 | <input type="checkbox"/> |
| Optical 4 | <input type="checkbox"/> | Optical 4 | <input type="checkbox"/> | Optical 4 | <input type="checkbox"/> | Optical 4 | <input type="checkbox"/> | Optical 4 | <input type="checkbox"/> |
| CD | | TAPE | | AUX 1 | | AUX 2 | | DC TRIGGER | |
| Device _____ | | Device _____ | | Device _____ | | Device _____ | | MAIN _____ | |
| Surr Mode _____ | | Surr Mode _____ | | Surr Mode _____ | | Surr Mode _____ | | ZONE _____ | |
| Analog | <input type="checkbox"/> | Analog | <input type="checkbox"/> | Analog | <input type="checkbox"/> | Analog | <input type="checkbox"/> | EXT REMOTE | |
| Coaxial 1 | <input type="checkbox"/> | Coaxial 1 | <input type="checkbox"/> | Coaxial 1 | <input type="checkbox"/> | Coaxial 1 | <input type="checkbox"/> | | |
| Coaxial 2 | <input type="checkbox"/> | Coaxial 2 | <input type="checkbox"/> | Coaxial 2 | <input type="checkbox"/> | Coaxial 2 | <input type="checkbox"/> | MAIN _____ | |
| Optical 1 | <input type="checkbox"/> | Optical 1 | <input type="checkbox"/> | Optical 1 | <input type="checkbox"/> | Optical 1 | <input type="checkbox"/> | ZONE _____ | |
| Optical 2 | <input type="checkbox"/> | Optical 2 | <input type="checkbox"/> | Optical 2 | <input type="checkbox"/> | Optical 2 | <input type="checkbox"/> | | |
| Optical 3 | <input type="checkbox"/> | Optical 3 | <input type="checkbox"/> | Optical 3 | <input type="checkbox"/> | Optical 3 | <input type="checkbox"/> | | |
| Optical 4 | <input type="checkbox"/> | Optical 4 | <input type="checkbox"/> | Optical 4 | <input type="checkbox"/> | Optical 4 | <input type="checkbox"/> | | |
| MONITOR OUT | | ZONE OUT | | DIG OUT COAX | | DIG OUT OPT | | MULTI CH IN | |
| Device _____ | | Device _____ | | Device _____ | | Device _____ | | Device _____ | |
| _____ | | _____ | | _____ | | _____ | | _____ | |
| Video | | | | | | | | | |
| Composite | <input type="checkbox"/> | | | | | | | Analog Bass Management <input type="checkbox"/> Yes <input type="checkbox"/> No | |
| S-Video | <input type="checkbox"/> | | | | | | | | |
| Component | <input type="checkbox"/> | | | | | | | | |

Use this chart to make a record of the setting and connections made from your system components to the Model 950

Connecting Audio Components

CD Player

Analog Connect the L and R channel outputs on the CD player to the CD IN jacks on the Model 950.

Digital If your CD player has a digital output jack, connect it to one of the coaxial (COAX 1 or 2) or optical (OPT 1-4) input jacks on the preamp/processor, depending on the type of connector used by the CD player. Later, you will configure the Model 950 to use the specific input that you have chosen. For now, note which digital input you connected to on your system chart.

Audio Recorder

A recording device such as a cassette deck, MD recorder, DAT deck or CD recorder can be connected to the Model 950 using either or both of the following methods.

Analog Connect the L and R audio outputs on the recorder (usually marked PLAY) to the TAPE IN jacks on the rear of the preamp/processor and connect the L and R audio inputs (usually marked REC) to the TAPE OUT jacks of the Model 950.

Digital If your recorder has a digital output jack, connect it to one of the coaxial (COAX 1 or 2) or optical (OPT 1-4) input jacks on the preamp/processor, depending on the type of connector used by the device. Later, you will configure the Model 950 to use the specific input that you have chosen. For now, note which digital input you connected to on your system chart.

If your recorder has a digital input jack, connect it to either the coaxial or optical output jack on the preamp/processor. The signal from the selected digital input source of the Model 950 will be sent to the recorder.

Connecting Video Components

Before making connections to any video devices, it will help to understand how the Model 950 routes the video portion of the signal through its video section.

- Any signal that appears at one of the composite video input jacks (DVD, VIDEO 1, 2 or 3) is automatically sent to the composite video OUT and VCR OUT jacks, as well as the S-Video OUT and VCR OUT jacks.
- Any signal that appears at the S-Video input jacks (DVD, VIDEO 1, 2 or 3) is automatically sent to the S-Video OUT and VCR OUT jacks, as well as the composite video OUT and VCR OUT jacks.
- Any signal that appears at the component video (DVD or VIDEO 1) input jacks is automatically sent to the component video MONITOR OUT connection only.

NOTE: To provide the greatest signal flexibility, be sure to connect all available types of inputs and outputs from your video devices. For example, if only the composite video output (yellow RCA jack) connection is made to your display device, component sources will not be available, even if they are connected to the Model 950.

DVD Player

Composite Connect the composite video output from the DVD player to the DVD video input jack on the rear of the Model 950 using an RCA-type video cable.

S-Video If there is an S-Video output on the DVD player, and you have an S-Video input on your TV or monitor, connect it to the S-Video DVD input on the rear of the Model 950 using an S-Video cable. S-Video delivers a better picture than composite connections and should be used whenever possible unless you can use component connections, which deliver better video than S-Video.

Component If the DVD player has component video outputs, connect them to the DVD component video input jacks on the rear of the Model 950 using an appropriate cable set.

Analog Audio Connect the L and R channel outputs on the DVD player to the DVD IN audio jacks on the rear of the Model 950.

Digital Audio Connect one of the digital output jacks on the DVD player to one of the coaxial (COAX 1 or 2) or optical (OPT 1-4) input jacks on the rear of the preamp/processor, depending on the type of connector used by the DVD player. Later, you will configure the Model 950 to use the specific input that you have chosen. For now, note which digital input you connected to on your system chart.

Multi-channel Audio If your DVD player supplies a multi-channel audio output (for DVD Audio or SACD playback), connect the six outputs (special cable sets for this are available from numerous sources, including Outlaw Audio) from your player to the six input jacks labeled MULTI CHANNEL INPUT on the rear panel of the Model 950. Be sure match the connections—left to left, right surround to right surround, and so on. If your player includes a built-in Dolby Digital decoder and has 5.1 channel analog audio outputs we suggest that you do not use them, but use the digital audio connection and the Model 950's internal decoders instead.

If you are connecting a DVD-Audio or SACD player to the Model 950 using these jacks, you will need to consider the setting for the Analog Bass Management switch on the Model 950's rear panel. If your system uses all full range speakers, set the switch in the OFF position. In that setting the signal will be routed directly from the input jacks to the volume control.

However, if your system uses small, frequency-restricted satellite speakers, the switch should be set to the ON position. In that setting the signals sent to the main speakers will be cut at 80 Hz and a summed bass signal will be sent to the subwoofer output. Note that you should place this switch in the OFF position if your playback source includes internal bass management circuitry or if you use an external bass manager such as Outlaw's ICBM-1 between the player and the Model 950.

Video Recorder

A video recording device such as a VCR, PVR (such as a TiVo®, Replay®, UltimateTV®, DishPlayer® or similar device) or DVD recorder can be connected to the Model 950 using the following methods.

Composite Connect the composite video output from the recording device to the VCR IN composite video jack on the rear of the preamp/processor. Connect the recording device's composite video input to the VCR OUT composite video jack of the Model 950 using an RCA-type video cable.

S-Video If there is an S-Video output on the recording device, connect it to the S-Video VCR IN input on the rear of the preamp/processor and connect the S-Video input to the S-Video VCR OUT using an S-Video cable. S-Video delivers a better picture than composite connections and should be used whenever possible unless you can use component connections, which deliver better video than S-Video.

Component If the recording device has component video outputs, connect them to one of the component video input jacks (DVD or VIDEO 1) on the rear of the preamp/processor using an appropriate cable set.

Analog Audio Connect the L and R audio outputs on the recorder to the VCR IN audio jacks on the rear of the preamp/processor and connect the L and R inputs of the recorder to the VCR OUT audio jacks on the Model 950.

Digital Audio If your recording device also has a digital audio output jack, connect it to one of the coaxial (COAX 1 or 2) or optical (OPT 1-4) input jacks on the rear of the preamp/processor, depending on the type of connector used by the device. Later, you will configure the Model 950 to use the specific input that you have chosen. For now, note which digital input you connected to on your system chart.

If your recording device also has a digital input jack, connect it to either the coaxial or optical output jack on the rear of the preamp/processor, depending on the type of connector used by the device. The signal from the selected input source of the Model 950 will be sent to the recorder .

Video Display

A video display device such as a television monitor, fixed-pixel device (plasma or LCD) or video projector can be connected to the Model 950 using the following methods.

Composite Connect the composite video input from the display to the composite video OUT jack on the rear of the Model 950 using an RCA-type video cable.

S-Video If there is an S-Video input on the display, connect it to the S-Video OUT jack on the rear of the preamp/processor using an S-Video cable. S-Video delivers a better picture than composite connections and should be used whenever possible unless you can use component connections, which deliver better video than S-Video.

Component If the display has component video inputs, connect them to the component video MONITOR OUT jacks on the rear of the Model 950 using an appropriate cable set.

NOTE: Since the Model 950 converts composite video to S-Video and vice versa, you need only make one of those two types of connections between the Model 950 and your video display. However, when component video connections are used it is still necessary to make either the composite or S-Video connections so that you are able to view the on-screen menus and displays which do not appear on the component outputs. The Model 950 does not convert from either composite or S-Video to component or vice versa.

Satellite Tuner or Television

Composite Connect the composite video output from the satellite tuner or television to one of the video input jacks (VIDEO 1, 2 or 3) on the rear of the Model 950 using an RCA-type video cable.

S-Video If there is an S-Video output on the satellite tuner or television, connect it to one of the S-Video inputs (VIDEO 1, 2 or 3) on the rear of the Model 950 using an S-Video cable. S-Video delivers a better picture than composite connections and should be used whenever possible unless you can use component connections, which deliver better video than S-Video.

Component If the satellite tuner or television has component video outputs, connect them to one of the component video input jacks (DVD or VIDEO 1) on the rear of the Model 950 using an appropriate cable set.

Analog Audio Connect the L and R channel outputs on the satellite tuner or television to the set of audio input jacks (VIDEO 1, 2 or 3) directly under the video jack used on the rear of the Model 950.

Digital Audio If your satellite tuner or television has a digital output jack, connect it to one of the coaxial (COAX 1 or 2) or optical (OPT 1-4) input jacks on the rear of the preamp/processor, depending on the type of connector used by the device. Later, you will configure the Model 950 to use the specific input that you have chosen. For now, note which digital input you connected to on your system chart.

FM Antenna

Connect the supplied FM antenna to the terminal labeled FM75Ω. Do not over tighten as this may damage the connection.

The supplied FM antenna is for indoor use only. For best signal reception you must fully extend the antenna. Experiment with the antenna's position to obtain the strongest signal. You can attach it to a wall or other surface using push pins or similar apparatus.

If FM reception is poor with the supplied indoor antenna, the use of an amplified indoor or outdoor antenna is recommended.

NOTE: You can only connect a 75Ω type FM antenna to the Model 950. If you choose to use an antenna other than the one supplied, be sure to verify that it has the correct type of connector or that you obtain an appropriate adaptor.

Try to avoid using the same antenna for both FM and TV reception since the signals can interfere with each other. If you must use a common FM/TV antenna, be sure that you install an splitter to separate the two signals.

AM Antenna

Connect the AM antenna to the terminals labeled AM and E(arth) on the rear panel of the preamp/processor. Start by pressing the lever on the side of one of the terminals to the right. Next, insert one of the antenna wires into the opening. Finish by returning the lever to the up position, securing the wire. Do the same for the other wire to complete installation.

External Amplifier

IMPORTANT NOTE: *Before attempting to plug any jacks into any power amplifier verify that the power amplifier is turned off and/or disconnected from the AC mains. Failure to do so can potentially result in severe damage to your amplifier and loudspeakers.*

Use the audio jacks labeled OUTPUT to connect the Model 950 to an external power amplifier such as the Outlaw Audio Model 770 Power Amplifier. The Model 950 can output up to 7.1 channels of sound (seven satellite and one subwoofer channel) depending on source components and material.

The output jacks supplied by the Model 950 are: Left Front, Center, Right Front, Left Surround, Right Surround, Left Surround Back, Right Surround Back, and Subwoofer.

Be sure to verify that the correct outputs are connected to the appropriate input jacks (Left Front to Left Front, Right Surround Back to Right Surround Back, etc..)

When a powered subwoofer is used, connect the Subwoofer output jack to the Line Input jack on your subwoofer and follow any specific connection and/or configuration instructions supplied with the subwoofer. If your subwoofer is a passive speaker, connect the subwoofer output jack on the Model 950 to the input of the amplifier used to power the subwoofer, and then connect the subwoofer speaker itself to the amplifier.

Second Zone

Use the L and R channel ZONE OUT audio jacks to connect the Model 950 to the analog audio inputs of an external amplifier or other audio component in a second zone. The signal present will reflect the input selection of the Model 950. This may be adjusted using the Zone Menu or the MULTI button on the remote control.

Power Control Connections

The DC TRIGGER jacks are used to remotely turn-on other devices in your system when the Model 950 is powered on. Power is applied to the MAIN Trigger Output jack when the Model 950 is turned on from the Standby Mode. We recommend that this jack be used to turn on a compatible power amplifier such as those available from Outlaw, but it may also be used to activate compatible products such as projection screens or motorized blinds.

Connect a 3.5mm mono mini-plug between the DC Trigger MAIN jack on the rear panel of the Model 950 and the low voltage trigger jack of the device to be controlled to enable remote turn-on of that component. The ZONE Trigger jack is activated when the Multiroom system is turned on and should be used for control of amplifiers used to power the speakers installed in the remote zone. It will remain activated as long as the Multiroom system is on, even when the Model 950 is in the Standby mode for the main room.

Remote Control

The EXT REMOTE jacks allow you to extend the on-board remote control sensor on the Model 950's front panel so that you may continue to control the 950 even when it is installed behind solid or smoked cabinet doors or when the front panel sensor is otherwise not visible to the remote control.

To extend the remote sensor connect an optional remote sensor to the MAIN jack.

The ZONE jack is provided to enable remote control of the Model 950's multi-zone system through the use of an optional remote sensor in the second zone. Connect the sensor to the ZONE jack using a 3.5mm mono mini-plug and the wiring specified by the sensor's manufacturer.

Power Connection

Insert the supplied power cord into the AC input of the rear panel of the preamp/processor. Do not use a power cord other than the one supplied with the Model 950. It's designed for use with the Model 950 and should not be used with any other device.

CAUTION: *Before you plug the power cord into an AC wall outlet, confirm that all connections to the preamp/processor have been made correctly.*

WARNING: *Never disconnect the power cord from the Model 950 while the other end is plugged into an AC outlet. Doing so may cause an electric shock. Always connect power by plugging into the AC outlet last and disconnect by unplugging from the AC outlet first.*

System Setup

At this point you should have made all the necessary physical connections between the Model 950 and your source equipment, amplifiers and speakers. All that remains is to properly configure the system to reflect your specific equipment and room characteristics.

To turn the Model 950 on:

1. Plug the cord into an AC wall outlet or UL approved power strip or surge protection device.

Make certain that the AC power cord supplied with the Model 950 is firmly inserted into the socket on the unit's rear panel.

2. Press the rear panel POWER switch to the On position to set the Model 950 to Standby mode.

The Standby Indicator on the Front Panel will light up.

3. Press the front panel Standby Power button to turn on the Model 950 or press the AUD button on the remote control.

The FRONT PANEL DISPLAY will light up and the standby indicator will turn off.

Navigating the Setup Menus

Setup of the Model 950 can be performed from the front panel of the unit, or by using the remote control. Information is shown on the Front Panel Display, or the On Screen Display (OSD). All selections are made using a combination of the following buttons:

Front Panel The MENU, Navigation (<, >, √ and ^) and SELECT buttons below the Front Panel Display

Remote Control The MENU, Navigation (<, >, √ and ^) and SEL/PLAY buttons in the center of the remote.

These buttons will be referred to interchangeably, unless otherwise specified, when referring to the Setup Menus.

The following example demonstrates how to navigate the Model 950 menu system in general using the Speaker Configuration menu as an illustration. For detailed information on a specific part of the setup process, consult the pages relating to that topic.

To use the Model 950 menu system:

1. Press the MENU button to display the Main Menu.

The Main Menu appears on the Front Panel Display and the OSD:

| | |
|--------------------------------------|--|
| MAIN MENU INPUT CONFIG | MAIN MENU > INPUT CONFIG SPEAKER CONFIG CHANNEL CALIB CHANNEL CONFIG SYSTEM CONFIG MULTI-ZONE PLII MUSIC PARAMETER EXIT |
|--------------------------------------|--|

2. Press √ or ^ to select a Setup menu.

Your selection appears on the Front Panel Display and the OSD:

| | |
|--|--|
| SPEAKER CONFIG FRONT : SMALL | SPEAKER CONFIG > FRONT : SMALL CENTER : SMALL SURR : SMALL SURR REAR : LB/RB SUBWOOFER : ON FRONT XOVER: 80Hz CENTER XOVER: 80Hz SURR XOVER: 80Hz RETURN TO MAIN MENU |
|--|--|

3. Press √ or ^ to select an item to adjust.

Your selection appears on the Front Panel Display and the OSD:

| | |
|---|---|
| SPEAKER CONFIG CENTER : SMALL | SPEAKER CONFIG > FRONT : SMALL > CENTER : SMALL SURR : SMALL SURR REAR : LB/RB SUBWOOFER : ON FRONT XOVER: 80Hz CENTER XOVER: 80Hz SURR XOVER: 80Hz RETURN TO MAIN MENU |
|---|---|

4. Press < or > to select or adjust a setting.

Your selection appears on the Front Panel Display and the OSD:

| | |
|---|---|
| SPEAKER CONFIG CENTER : LARGE | SPEAKER CONFIG > FRONT : SMALL > CENTER : LARGE SURR : SMALL SURR REAR : LB/RB SUBWOOFER : ON FRONT XOVER: 80Hz CENTER XOVER: 80Hz SURR XOVER: 80Hz RETURN TO MAIN MENU |
|---|---|

Once you have made your selections, you can use the √ and ^ to return to the Main Menu and/or exit the menu system. Alternatively, pressing the MENU button once will return you to the Main Menu. Pressing the MENU button a second time will exit the menu system. Note that the menus will remain visible on the Front Panel and OSD until you exit the menu system.

IMPORTANT NOTE: When viewing static images such as on screen menus or video game images using a CRT-based projector, plasma display or direct-view CRT monitor or television, there is a risk of permanently "burning in" the image. Do not leave these images on for an extended period of time. This type of damage is not covered by the Outlaw Audio Model 950 warranty.

Input Setup and Selection

Before calibrating your Model 950 and adjusting loudspeaker setup and configuration, you should first set up the sources connected to it. You will make your selections using the Input Configuration menu, shown below.

Figure 1

| INPUT CONFIG | |
|---------------------|--------------------|
| > SOURCE | : DVD |
| INPUT | : OPTICAL1 |
| MODE | : DOLBY DIGITAL |
| TREBLE | : 0dB |
| BASS | : 0dB |
| NIGHT | : NO COMP |
| RETURN TO MAIN MENU | |

Because of the extensive options available for each input source, we strongly recommend you use the chart on page 18 to record the settings for each input and component. Later, if you re-configure your system, this chart will help avoid confusion.

To configure an input:

1. Press the MENU button to enter the Main Menu.

The Main Menu appears on the Front Panel Display and the OSD. The cursor on the OSD should be pointing to the Input Configuration menu and INPUT CONFIG appears on the Front Panel Display.

2. Press SELECT to enter the Input Configuration menu.

The Input Configuration menu appears on the Front Panel Display and the OSD (see figure 1). The selected menu item should be SOURCE.

3. Use the < and > buttons to select which particular Source you wish to configure.

The Source choices appear as follows as you scroll through them:

DVD→VIDEO1→VIDEO2→VIDEO3→VCR→TUNER→CD
→TAPE→AUX1→AUX 2

You can scroll in either direction using the < and > buttons .

4. Press the √ button once to select the Input menu.
5. Use the < and > buttons to select an Input for that source.

The input choices appear as follows as you scroll through them:

ANALOG→OPTICAL1→OPTICAL2→OPTICAL3→
OPTICAL4→COAXIAL1→COAXIAL2

You can scroll in either direction using the < and > buttons .

If you connected the source to the Analog inputs, select: ANALOG.

If you connected the source to one of the Optical Digital inputs, select the appropriate one by choosing: OPTICAL 1, 2, 3, or 4.

If you connected the source to one of the Coaxial Digital inputs, select the appropriate one by choosing: COAXIAL 1 or 2.

NOTE: Always connect and configure the digital input source option if one is available from the specific component, as this will provide maximum performance and best sound quality.

Remember that you can always return to any menu to change your selection, should that be required.

6. Press the √ button once to select the Mode menu.
7. Use the < and > buttons to select a Mode for that source.

The available surround modes appear as follows as you scroll through them:

PLII - C→PLII - M→DOLBY PL→7 STEREO→
5 STEREO→STEREO→PLIIC+CR→PLIIM+CR→
NEO : 6 - C→NEO : 6 - M→DOLBY D→DOLBY EX→
DTS→DTS - ES

You can scroll in either direction using the < and > buttons .

You should choose a surround mode to be the default for this source. Please refer to the table on page 12 for a detailed listing of all options. Remember that all available mode options can be selected for a Digital input source, but certain modes will not be available through the Analog input for that source.

Selecting the default mode will not exclude other modes of surround decoding. In fact, certain digital signals (Dolby Digital, DTS, some Dolby Digital EX, and others) contain a special digital “flag” that tells the 950 to switch to that surround mode. When the Model 950 receives one of these bitstreams it will switch to that mode of operation. Additionally, you can manually cycle through the available modes while the source is playing to choose the one you wish to use.

8. Press the √ button once to select the Treble menu.
9. Use the < and > buttons to adjust the Treble.

The amount of Treble boost can be adjusted ±6dB in 2dB increments.

10. Press the √ button once to select the Bass menu.
11. Use the < and > buttons to adjust the Bass.

The amount of Bass boost can be adjusted ±6dB in 2dB increments.

NOTE: Any tone control setting you make in this mode are global, and will affect all input sources and all output channels. They will remain in effect until you go back into the setup menu and change them or change them using the TONE button on the remote control.

12. Press the √ button to select the Night menu.

NOTE: This option only operates with a Dolby Digital or Dolby Digital EX source and one of these modes is active.

This option allows you to set the amount of Dynamic Range Compression used when the Model 950 is placed into the NIGHT mode. This mode can also be selected by pressing the NIGHT button on the remote control.

There are two types of automatic compression control built into the Dolby Digital process. Compression makes the loud parts softer and the soft parts louder to reduce the difference between the two.

One type of compression is most useful for situations such as late night viewing of programs with a wide dynamic range (like many action movies) that might disturb others in your home. This function can also be used to provide compression for program material that may require enhancement of overall intelligibility (such as some older soundtracks).

Another feature provided by this option is the necessary peak limiting required to avoid signal overload when "down-mixing" functions are selected.

The second variable provides additional peak limiting to allow overall average program level to be increased by adding even more compression to the signal.

These two algorithms can provide sufficient overall gain reduction to allow even wide dynamic range soundtracks with very soft parts and very loud parts to maintain good audibility at low volume levels.

In most cases a minimum amount of dynamic range reduction is automatically included in the bitstream to ensure safe down-mixing.

13. Use the < and > buttons to select a Dynamic Range option you prefer for the Night setting.

| | |
|----------|--|
| NO COMP | This option leaves the compression at 0% change. |
| DR COMP1 | This option increases the compression by 25%. |
| DR COMP2 | This option increases the compression by 50%. |
| DR COMP3 | This option increases the compression by 75%. |
| DR COMP4 | This option increases the compression by 100%. |

Each option increases the amount of Dynamic Range compression to the signal. Depending on your family, neighbors, circumstances, and the overall volume you wish to achieve, we recommend you start with DR COMP1 or DR COMP2 as your initial setting. You will have to experiment with program material and your personal preferences to determine what is acceptable and best for you.

14. Press the √ button to select the Return to Main Menu option.

15. Press the SELECT or MENU button to return to the Main Menu, or press the MENU button twice to exit the menu system.

NOTE: Except for the input source and surround mode, the settings chosen during this input setup process are universal and apply to all sources. You will need to correctly set each digital source to the appropriate input and select a default surround mode for each source connected to your Model 950. Once you have completed these selections, proceed to the next step: configuring your loudspeaker setup and calibrating your system.

Speaker Configuration

You are now ready to configure the 950 for your particular loudspeaker system. Before proceeding please read the following information carefully:

Speaker Placement

The best speaker placement for your particular room will depend on its size, furnishings, seating arrangement, the acoustical properties of the space, including wall type, coverings, and various other factors.

Due to the complex nature of these variables it is impossible to recommend any one-size-fits-all placement. You may well have to experiment with various placement options to determine the best configuration for your specific situation. Please note that, the configuration and placement of your speakers is critical for creating the best possible surround sound playback.

Here are some basic recommendations you should consider when positioning your speakers.

Front left, center and right speakers:

- These speakers should be placed at the same relative height from the floor and a similar distance from any walls. Most speakers sound best when located with the tweeter at ear height when you're seated. Typically, the further away from the walls the speakers are, the better they will sound.
- Insure that the speakers are aimed at the listener's ears within your chosen seating position.

Surround left and right speakers

- Place these speakers so that their height is approximately 1 meter (3 feet) higher than that of the listener's ears if feasible.

Surround back left and right speakers

These speakers are required for Surround EX, DTS-ES, DTS NEO:6 and Cirrus Extra Surround playback.

- Place these speakers behind the listener so that the angle between each speaker and the listener is approximately 30 degrees.
- Place these speakers so that their height is 1 meter (3 feet) higher than that of the listener's ears.

Note on dipole surround loudspeakers: Most dipole surround speakers have an arrow which indicates their proper orientation relative to your video display/screen. Dipoles placed on side walls should have the arrows pointing forward. Dipoles placed on a rear or back wall should have the arrows pointing towards each other to achieve the correct acoustical image in the room.

Subwoofer

Subwoofer placement can frequently be a trial and error affair as bass energy set up "standing waves" in most every room. These standing waves can cause areas with too much bass, areas with too little bass, and areas in between. You may have to move the subwoofer and/or the prime listening area to improve the bass response. Be aware that every surface you place the woofer close to (one wall, floor, two walls in a corner) will increase the overall apparent bass in the room. But this can potentially lead to boomy and muddy sounding bass.

When connecting any speakers, be sure to read the instruction manuals that came with the product and check your power amplifier's instruction manual for proper hook-up of the loudspeakers.

Speaker Placement

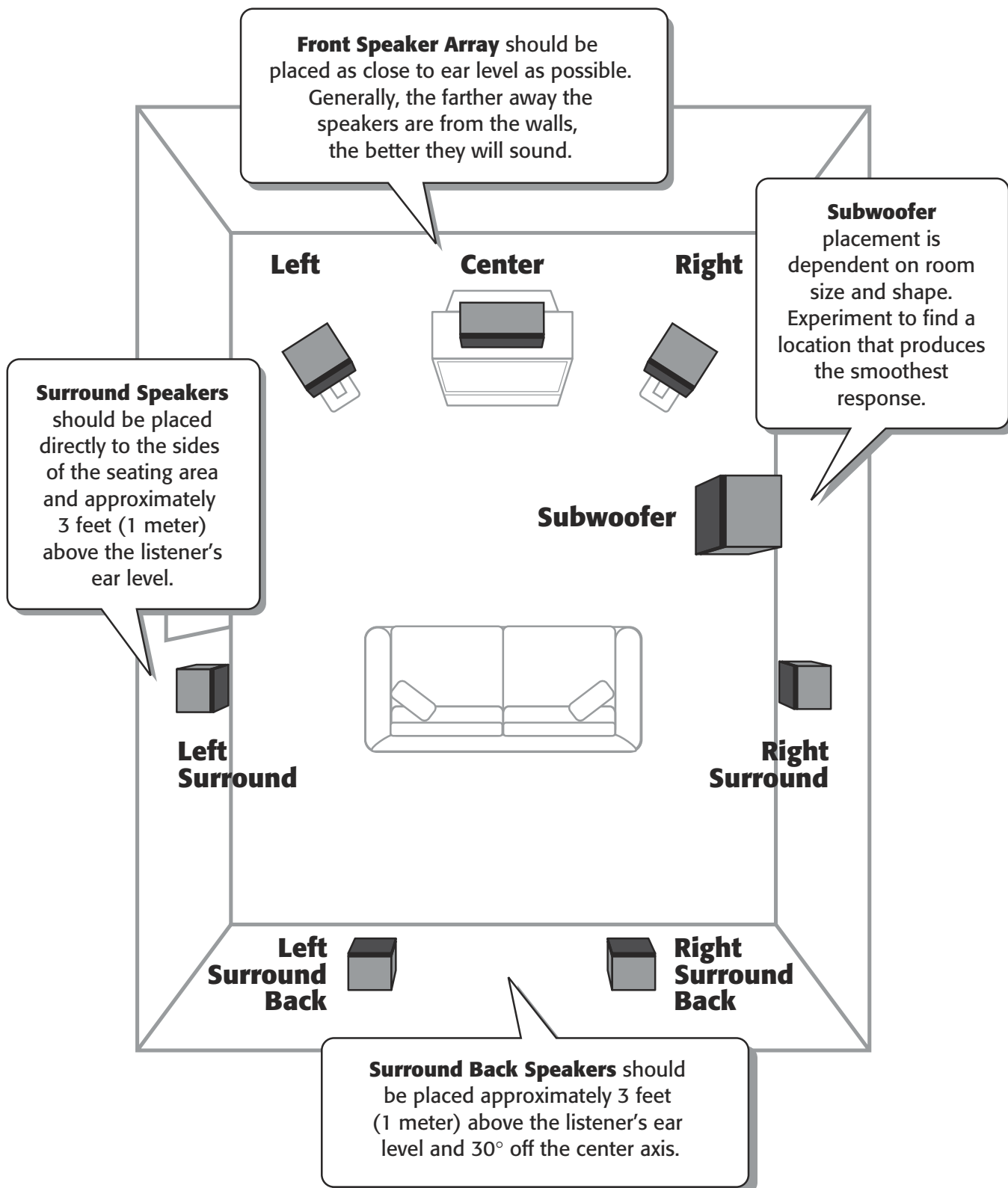

The first step in configuring the 950 to operate with your speaker system is to set the type, number and crossover frequencies of your particular loudspeakers. You make these selections using the Speaker Configuration menu shown below.

Figure 2

```
SPEAKER CONFIG
> FRONT      : SMALL
  CENTER     : SMALL
  SURR       : SMALL
  SURR REAR  : LB/RB
  SUBWOOFER  : ON
  FRONT XOVER : 100Hz
  CENTER XOVER : 100Hz
  SURR XOVER  : 100Hz
  RETURN TO MAIN MENU
```

To configure the Model 950 for your speaker system:

1. Press the MENU button to enter the Main Menu.

The Main Menu appears on the Front Panel Display and the OSD. The cursor on the OSD should be pointing to the Input Configuration menu and INPUT CONFIG appears on the Front Panel Display.

2. Press the ∇ button once to select the Speaker Configuration menu.

The cursor on the OSD should be pointing to the Speaker Configuration menu and SPEAKER CONFIG appears on the Front Panel Display.

3. Press SELECT to enter the Speaker Configuration menu.

The Speaker Configuration menu appears on the Front Panel Display and the OSD (see figure 2). The selected menu item should be FRONT.

The first three settings in the Speaker configuration menu deal with the type of speakers you are using in your system. It is very important that you understand what is meant by the LARGE and SMALL settings in this menu. They do not refer to the physical size of the speakers, but to their ability to handle very powerful deep bass. Most loudspeaker systems on the market should be classified as Small, since they do not have the capability to handle the often extraordinary amount of deep bass content film soundtracks can contain.

It is strongly recommended that you consult your loudspeaker instruction manual regarding the capabilities of your particular system with regard to low bass/low frequency reproduction.

Please note that all THX certified loudspeaker systems are classified under this method as SMALL since a subwoofer is required for any THX certified loudspeaker system.

In any case you should consider using a subwoofer for any system which you expect to effectively handle the low frequency dynamics of modern motion picture soundtrack sources such as DVD or HDTV feeds, and many other discrete multi-channel programming sources.

If you aren't sure about your speaker's real world capabilities and you are using a subwoofer, choose Small, since this will insure that all the appropriate low frequency information is directed to the subwoofer where it can be most effectively handled.

4. Use the < and > buttons to cycle through the speaker options for the FRONT speaker.

The following options are available for each group of loudspeakers:

- For FRONT you can select SMALL or LARGE
- For CENTER you can select SMALL, LARGE or NONE
- For SURR(OUNDS) you can select SMALL, LARGE or NONE
- For SURR(OUNDS) REAR you can select BS(LB), LB/RB or NONE

LB/RB means you have a Left Back and Right Back rear surround speaker setup for use in a 7.1 configuration. BS(LB) means you have a single centrally placed BACK Surround speaker for use in a 6.1 (EX) type configuration.

- For SUBWOOFER you can select ON or OFF

5. Press the ∇ button when you have made a selection.

Repeat steps 4 and 5 until you have completed selecting the speaker type for each loudspeaker in your system.

6. Press the ∇ button when you are finished to select the Front Crossover (XOVER) menu.

The Front, Center and Surround Crossover menus are used to independently set the internal High Pass filter of the Model 950's Cirrus Triple Crossover for each of these three speaker groups.

7. Use the < and > buttons to adjust the Front Crossover.

The crossover settings appear as follows as you scroll through them:

40Hz→60Hz→80Hz→100Hz→120Hz→150Hz

You can scroll in either direction using the < and > buttons.

Consult the material that came with your loudspeakers to determine the correct settings, if any are recommended. The THX standard is 80Hz. In general, if you are not sure about the frequency response of your speakers, we recommend you set the crossover at 80Hz, unless otherwise directed by the manufacturer. If you are using very small satellite speakers you may need to set the crossovers to 100 or even 120Hz. When correctly set, you should hear a smooth transition of lower to upper bass between the satellites and the subwoofer.

8. Press the ∇ button when you have made a selection.

Repeat steps 7 and 8 until you have completed the speaker crossover settings for each group of speakers.

9. Press the ∇ button to select the Return to Main Menu option.

10. Press the SELECT or MENU button to return to the Main Menu, or press the MENU button twice to exit the menu system.

Channel Calibration

The next step is to adjust the output level of each channel so that they are properly matched. This must be done to insure a correct presentation of multi-channel sound sources. The adjustment must be as precise as possible, and is almost impossible to accomplish by ear. Therefore, we recommend that you use a Sound Level Meter. This device insures that all loudspeaker levels are precisely matched and set accurately. (The Radio Shack Analog Sound level Meter is inexpensive and suitable for this task.)

NOTE: If for any reason you are not sure that you can accomplish this calibration task or have any doubts as to how it should be done, please contact Outlaw Audio's technical support BEFORE attempting this process.

Set the meter to Slow response and "C" weighting. Set it to the 70 or 80dB sensitivity scale. Position the meter at the approximate center of your listening area, at average ear height [approximately 40-46 inches (102-117 cm)] with its microphone positioned vertically (pointing at the ceiling). Don't aim the microphone at the speakers, as this will produce inaccurate results.

To proceed with the adjustments, you will access the Channel Calibration menu shown below.

Figure 3

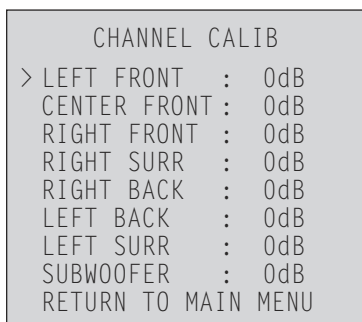

With no source playing, set the volume level of the Model 950, using the main volume control, to 0dB.

To set the channel levels for you system:

1. Press the MENU button to enter the Main Menu.

The Main Menu appears on the Front Panel Display and the OSD. The cursor on the OSD should be pointing to the Input Configuration menu and INPUT CONFIG appears on the Front Panel Display.

2. Press the √ button until the Channel Calibration menu is selected.

The cursor on the OSD should be pointing to the Channel Calibration menu and CHANNEL CALIB appears on the Front Panel Display.

3. Press SELECT to enter the Channel Calibration menu.

The Channel Calibration menu appears on the Front Panel Display and the OSD (see figure 3). The selected menu item should be LEFT FRONT.

A special test tone will be generated allowing you to measure the output of the speaker that's playing.

Note: If the test tone is too loud with the main volume level set at 0dB reset it to -10dB and proceed with the calibration as described.

4. Use the < and > buttons to adjust the speaker level.

You can adjust the selected channel level in 1dB steps across a range of -15dB to +10dB. The recommended calibration level is 75dB/SPL as displayed on the meter.

5. Press the √ button when you have finished making the Left Front level adjustment.

Repeat steps 5 and 6 until you have completed setting the level for each speaker in your system. Set all the levels to 75dB.

6. When you have finished adjusting the level for all the speakers in your system, press the √ button to select the Return to Main Menu option.

7. Press the SELECT or MENU button to return to the Main Menu, or press the MENU button twice to exit.

You can also perform this calibration at any time by using the built in test tone, by pressing the TEST button the front panel of the Model 950 or the remote control.

To set channel levels using the Test Tone function:

1. Press the TEST TONE button on the front panel or TEST button on the remote.

This will produce a display that shows:



When you select this function, the Model 950's Test Tone will automatically cycle every few seconds through all the speakers you have told the Model 950 are connected to the system.

The unit cycles through the speakers in the following sequence:

LEFT FRONT→CENTER FRONT→RIGHT FRONT→ RIGHT SURR(OUND)→RIGHT BACK (SURROUND)→LEFT BACK (SURROUND)→LEFT SURR(OUND)→SUBWOOFER

2. Use the < and > buttons to adjust the speaker level.

You can adjust the selected channel level in 1dB steps across a range of -15dB to +10dB.

While you are adjusting each speaker, the Test Tone will remain on that channel until you have stopped changing the volume for a few seconds. The unit will then resume cycling the Test Tone from speaker to speaker, until you touch the TEST TONE button again.

NOTE: Speakers that you selected "None" for in the Speaker Config menu will not appear.

3. Press the TEST TONE button on the front panel or the TEST button on the remote control again to exit the Test Tone function.

System Configuration

The System Configuration menu is used to enter Speaker Distances (for proper sound delay), set Display parameters, operate the Sleep Timer, and turn Theater Compensation on or off. The Display, Sleep Timer and Theater Compensation settings are covered in the section titled "Operation." The System Configuration menu is shown below.

Figure 4

```
SYSTEM CONFIG
> FRONT  DISTANCE: 10ft
  CENTER DISTANCE: 10ft
  SURR   DISTANCE:  3ft
  VFD   BRIGHTNESS: FULL
  OSD TIME OUT : 5Sec
  SLEEP TIME SET: 0Min
  THEATER COMPEN: OFF
  DISTANCE UNIT : FEET
  RETURN TO MAIN MENU
```

Setting The Speaker Distance Delays

Setting the speaker delay is crucial to the proper performance of any surround decoder component like the Model 950. Your home theater system will not perform properly if this process is not completed.

To accomplish this process you will need a tape measure or other means of determining the distance of each speaker from the primary listening position.

To set the speaker distance delays for your speakers:

1. Press the MENU button to enter the Main Menu.

The Main Menu appears on the Front Panel Display and the OSD. The cursor on the OSD should be pointing to the Input Configuration menu and INPUT CONFIG appears on the Front Panel Display.

2. Press the √ button until the System Configuration menu is selected.

The cursor on the OSD should be pointing to the System Configuration menu and SYSTEM CONFIG appears on the Front Panel Display.

3. Press SELECT to enter the System Configuration menu.

The System Configuration menu appears on the Front Panel Display and the OSD (see figure 4). The selected menu item should be FRONT DISTANCE.

Before setting the speaker distances, you need to choose what unit of distance you will be using.

4. Press the √ button repeatedly until the Distance Unit menu is selected.
5. Use the < and > buttons to select between Feet and Meters.

6. Press the ^ button repeatedly until you return to the Front Distance menu.

To set the distance for each group speakers in your system, you will need to measure, as precisely as possible, the distances from your chosen listening/viewing position to the various loudspeakers in your system.

Set the distance for the Front L/R speakers to the nearest foot/meter.

Rounding up is OK. Distances can be set in the following increments:

Feet 0 to 20 feet in 1 foot increments.

Meters 0 to 6 meters in 0.3 meter increments.

You can scroll in either direction using the < and > buttons.

7. Press the √ button when you have made a selection.

Repeat steps 6 and 7 for the Center and Surround speakers.

You should note your final settings above for future reference. Use the spaces below to enter the distances for your speaker setup.

L/R []m/ft C []m/ft SL/SR []m/ft

NOTE: There is no delay function for the subwoofer

8. Press the √ button until the Return to Main Menu option is selected.
9. Press the MENU button to return to the Main Menu, or press the MENU button twice to exit.

Dolby Pro Logic II (PLII) Music Parameter

The PLII Music Parameter menu is used to adjust the Panorama, Dimension and Center Width processing options when listening to music in the Dolby Pro Logic II surround mode. For a description of these options, see page 12 in the section titled "Surround Format Information." The PLII Parameter menu is shown below.

Figure 5

```
PLII MUSIC PARAMETER
> PANORAMA : OFF
  DIMENSION : STEP 0
  C WIDTH   : STEP 0

RETURN TO MAIN MENU
```

To adjust the PLII Music Parameters:

1. Press the MENU button to enter the Main Menu.

The Main Menu appears on the Front Panel Display and the OSD. The cursor on the OSD should be pointing to the Input Configuration menu and INPUT CONFIG appears on the Front Panel Display.

2. Press the √ button until the PLII Music Parameter menu is selected.

The cursor on the OSD should be pointing to the PLII Music Parameter menu and PLII MUSIC PARAMETER appears on the Front Panel Display.

3. Press SELECT to enter the PLII Music Parameter menu.

The PLII Music Parameter menu appears on the Front Panel Display and the OSD (see figure 5). The selected menu item should be PANORAMA.

4. Use the < and > buttons to select between On and Off.

When this setting is On, Pro Logic II's Panorama circuits will blend an amount of the front channel information into the side speakers so that the soundfield appears to wrap around the front and sides of the soundstage. Experiment with a variety of program sources to see if this effect is one you prefer.

5. Press the √ button to select the Dimension menu.

6. Use the < and > buttons to cycle through the Dimension options.

The Dimension settings appear as follows as you scroll through them:

STEP 0→STEP 1→STEP 2→STEP 3→STEP -3→STEP -2→STEP -1

You can scroll in either direction using the < and > buttons .

The Dimension Control uses special circuitry to give the impression that the "center" of the soundfield is moving towards the front or rear of the room. Experiment with a variety of program sources to see if this effect is one you prefer. Use as much or as little Dimension as you feel is needed.

7. Press the √ button to select the C Width menu.

8. Use the < and > buttons to cycle through the C Width options.

The C Width settings appear as follows as you scroll through them:

STEP 0→STEP 1→STEP 2→STEP 3→STEP 4→STEP 5→STEP 6→STEP 7

You can scroll in either direction using the < and > buttons .

Depending on how the Center Width control is set, you may adjust the apparent placement of the center channel image so that it is heard only from the center speaker, so that it is blended into the left and right speakers as a phantom image, or that it is blended among the front left, center and right speakers in varying amounts. As with the other Pro Logic II controls, the use of this setting and the degree to which it is used is a matter of personal preference.

9. Press the √ button to select the Return to Main Menu option.

10. Press the MENU button to return to the Main Menu, or press the MENU button twice to exit.

Multi-zone

This menu controls the setting for your second zone and the output from the ZONE OUT jacks on the rear of the Model 950.

This function can be accessed in two ways. You can press the MULTI button on the remote control, or you can access this feature through the MAIN MENU. The Multi-zone menu is shown below.

Figure 6

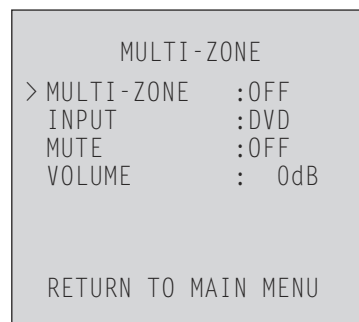

To adjust the Multi-zone settings:

1. Press the MENU button to enter the Main Menu.

The Main Menu appears on the Front Panel Display and the OSD. The cursor on the OSD should be pointing to the Input Configuration menu and INPUT CONFIG appears on the Front Panel Display.

2. Press the √ button until the Multi-zone menu is selected.

The cursor on the OSD should be pointing to the Multi-zone menu and MULTI - ZONE appears on the Front Panel Display.

3. Press SELECT to enter the Multi-zone menu.

The Multi-zone menu appears on the Front Panel Display and the OSD (see figure 6). The selected menu item should be MULTI - ZONE.

4. Use the < and > buttons to select whether you want the Multi-zone feature On or Off.

If ON is selected, the yellow LED below the word MULTI on the front panel will illuminate indicating activation of the second stereo zone.

5. Press the √ button to select the Input menu.

6. Use the < and > buttons to select which source signal will be sent through the ZONE OUT outputs to the second zone.

The Source choices appear as follows as you scroll through them:

DVD→VIDEO1→VIDEO2→VIDEO3→VCR→TUNER→CD→TAPE→AUX1→AUX 2

You can scroll in either direction using the < and > buttons .

7. Press the √ button to select the Mute menu.

8. Use the < and > buttons to select whether the Multi-zone mute function is On or Off.

9. Press the √ button to select the Volume menu.

10. Use the < and > buttons to increase or decrease the volume level of the signal being sent to the second zone.

The range available is from -80dB to 10dB. Use caution as you can set a very high volume level and not be aware of it because of the distance between you and the second zone.

11. Press the √ button to select the Return to Main Menu option.

12. Press the SELECT or MENU button to return to the Main Menu, or press the MENU button twice to exit.

Operation

Now that you have completed the initial setup and configuration of the Model 950, it is simple to operate and enjoy. Reading the following section will help you get the maximum pleasure from your new equipment. Make sure the unit is plugged in and the Main Power switch on the rear panel of the 950 is in the On position, as outlined in the "System Setup" section.

Direct Operation

In addition to entering settings into the Model 950 using the Menu System, as described in the System Setup section of this manual, many of the controls may be changed directly at any time using the remote control or front panel buttons. To change one of these settings (for example, Channel Trim), simply press the appropriate button on the remote or front panel and use the navigation buttons as required to change the settings.

Power

To turn the Model 950 on and off:

1. Press the front panel Standby Power button to turn on the Model 950, or press the AUD button on the remote control.

The FRONT PANEL DISPLAY will light up and the Standby indicator will turn off.

Alternatively, pressing any of the source selection buttons (DVD, CD, VCR, etc.) on the remote control will turn on the Model 950.

Powering the unit on this way sets the Model 950 to the selected source and sets control of the remote control to that source device. To control the Model 950, press the AUD button on the remote.

2. Press the Standby Power button on the front panel again or press the POWER button on the remote control to return the Model 950 to Standby mode.

The FRONT PANEL DISPLAY will go out and the Standby Indicator will light up.

Note that remote needs to be set to control the 950 (by pressing the AUD button) before the POWER button will turn off the unit.

Selecting a Source

Before you can listen to any input, you must first select that input as the source. This tells the Model 950 which input source to send out to the speakers and monitor.

To select an input source:

1. Press one of the Source buttons (DVD, CD, VCR, etc.) on the remote control or press the ∇ or \wedge SOURCE buttons on the front panel of the Model 950 to cycle through the input sources.

The Front Panel Display and the OSD will show the source you have selected. The settings displayed will be those that you set in the Input Configuration menu during initial setup. An example is shown below:

| | |
|----------|----------|
| DVD | DOLBY EX |
| OPTICAL1 | -10dB |

2. Press AUX 1 or AUX 2 on the remote to select one of the auxiliary audio input sources

NOTE: When a video input has been selected as the current source, its video signal will appear on the connected television or monitor. Changing the selected input to an audio-only source (CD, AUX 1, AUX 2, etc.) will switch the audio output to the new source, while leaving the previously selected video input active.

Selecting a Source Input

When you select a source from the 950's remote or front panel, the input selected during Input Configuration is automatically used as the source input. You can select another input by following the procedure below.

To select a source input:

1. Press the DIGITAL button on the remote control or the DIGITAL SELECT button on the front panel.

The next input in order will be chosen by the 950. Your selection will appear on the Front Panel Display and OSD.

| | |
|----------|---------|
| DVD | DOLBY D |
| OPTICAL1 | 00dB |

The input choices will display in the following order:

ANALOG→OPTICAL1→OPTICAL2→OPTICAL3→
OPTICAL4→COAXIAL1→COAXIAL2

2. Press the same button repeatedly to cycle through inputs.

Your selection becomes the new default input for that source.

| | |
|----------|---------|
| DVD | DOLBY D |
| COAXIAL1 | 00dB |

Volume Control

Use this control to adjust the volume level of all currently connected speakers.

To adjust the main volume level:

- Press the ∇ or \wedge VOL buttons on the remote or turn the VOLUME knob on the front panel to adjust the volume of the Model 950.

You can adjust the main volume level from -80dB to +10dB. 0dB corresponds to the approximate level you would hear in a properly calibrated movie theater. The volume level appears in front of the dB indicator on the Front Panel Display and OSD.

| | |
|----------|----------|
| DVD | DOLBY EX |
| OPTICAL1 | 00dB |

Note that the main volume control does not affect the volume level in the second zone.

Muting the Volume

Use this control to turn the sound off momentarily, such as when interrupted by a phone call.

To mute the main volume:

1. Press the MUTE button on the remote control or the front panel.

The sound will be muted and the On/Standby/Mute indicator will blink continuously. The word MUTE replaces the volume level on the Front Panel Display and OSD.

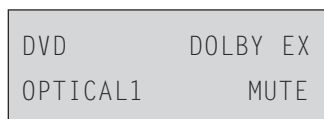

Note that the volume level in the second zone is not affected.

2. Press either MUTE button again to restore the volume to its previous level.

The On/Standby/Mute indicator will go out.

Changing the Surround Mode

Use these controls to change the surround mode from the default selected during Input Configuration.

1. Press one of the Surround mode buttons (DOLBY, DTS, CR SURR or STEREO) on the remote or the < and > SURR MODE buttons on the front panel.

When the 950 acquires a digital bitstream, the Front Panel Display and OSD will show what type it is (PCM, S/PDIF) and the number of channels (2/2, 2/0, 3/2.1, etc.) contained in the signal. An example is shown below:

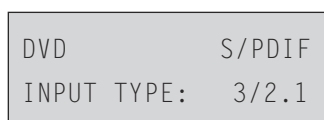

2. Press the button again to cycle through the available surround modes.

Only those modes that can be used with the currently selected source will be available as you cycle through the choices. Your selection will appear above the volume level on the Front Panel Display and OSD

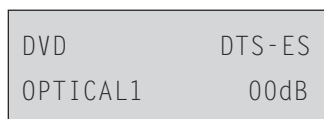

Use the information on page 12-13 to learn more about the available surround mode options.

Surround Data Format Lock

The Model 950 will automatically set the surround format based on the signal it receives from the selected source. To avoid the slight delay occasionally encountered in the Auto Select process, you can choose to override the Auto Data Format detection circuitry by following the procedure below.

To lock a specific surround mode:

1. Press the desired Surround Mode button (DOLBY, DTS, CR SURR or STEREO) on the remote control repeatedly to cycle through the available processing options.

Your selection will appear on the Front Panel Display and OSD.

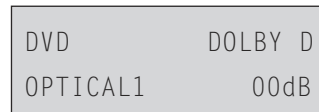

2. Press the same button for five (5) seconds to choose from among three data format options for digital audio sources.

The following is shown on the Front Panel Display and the OSD:



Auto is the Default setting for this option, and means that when the unit detects the special code imbedded within certain data streams such as Dolby Digital or DTS it will set itself to properly decode that type of incoming signal.

3. Use the < or > buttons to select one of the Data Format options.

You can select either Dolby Digital, DTS, or PCM (for Pro Logic II), as the default format. If you do this, signals that are not in the selected format won't be recognized. Therefore, we recommend that you leave the system in Auto Mode unless you wish to use the selected mode exclusively.

The Data Format menu will disappear automatically approximately 10 seconds after you make your selection.

Bypass Setting

When playing an analog input source you may bypass the Model 950's digital processing system and listen to the source in "pure" two-channel stereo.

To change the 950 to Stereo bypass mode:

1. Press the BYPASS button on the remote or the STEREO BYPASS button on the front panel

The source signal will be passed through without any digital processing. If the currently selected source input is digital (Coaxial or Optical), the 950 will automatically change to the analog input for that source and the show the information on the Front Panel Display and OSD. An example is shown below:

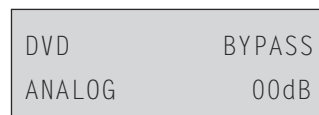

2. Press the button again to return the signal path to the digital system.

Tuner Operation

The Model 950 Tuner can receive AM, FM and FM stereo broadcasts. Up to 32 stations can be preset and accessed from the front panel or remote. Stations can also be tuned manually.

NOTE: Tuner reception cannot take place unless an appropriate AM and/or FM antenna is connected to the rear panel of the 950 as described on page 20.

To operate the tuner:

1. Press the AM/FM button on the remote control once, or press either SOURCE button on the front panel until the display shows:

```
TUNER 01-S STEREO
FM 100.1 MHz -10dB
```

This indicates that the Tuner is in FM, with Stereo selected as the Surround mode. The number displayed next to the Tuner text is the Preset number currently selected or last selected, followed by the Stereo reception indicator if the station is being received in stereo. The numbers next to the FM text are the frequency of the selected preset or station. The numbers in front of the dB indication are the current volume setting.

2. Press the AM/FM button on the remote control or the front panel to change between AM and FM bands.

```
TUNER 01 STEREO
AM 1000KHz -10dB
```

This display indicates that the Tuner is in AM with a selected preset and the frequency of that preset or station. The numbers in front of the dB indication are the current volume setting.

3. Use the ∇ and \wedge TUNE buttons on the front panel or the remote to change the tuner frequency.

The new frequency will be displayed to the left of the volume level on the Front Panel Display and OSD.

```
TUNER 01-S STEREO
FM 95.5 MHz -10dB
```

Pressing a TUNE button once increases or decreases the FM frequency by .1 MHz and the AM frequency by 10 KHz.

4. Press and hold either the ∇ and \wedge TUNE buttons on the front panel or the remote to scan continuously up or down the selected band. The tuner will stop on the next available station when you release the button.
5. Press the T.MODE button on the remote or the FM MODE button on the front panel to toggle between Stereo and Mono.

If an FM station produces lots of noise or sound that cuts in and out while in stereo, use this control to change the FM mode from Stereo to Mono.

If you select Mono as the operating mode an indicator will appear next to the preset number and the display will show:

```
TUNER 01-M STEREO
FM 95.5 MHz -10dB
```

To preset a radio station into memory:

1. Tune to the radio station you desire.
2. Press and hold the MEM button on the remote or the MEMORY button on the front panel to store a station into a preset location.

The display will change to show the word Memory along with a flashing number as shown below:

```
MEMORY 01-S STEREO
FM 99.9 MHz -10dB
```

3. Quickly enter the desired preset/memory location (01 through 32) using the numeric keypad on the remote.

This programs the radio station to that memory location. You have approximately 5 seconds to enter a number.

```
PRESET 01-S STEREO
FM 99.9 MHz -10dB
```

Up to 32 stations can be stored, randomly between AM and FM, in memory as presets.

To tune to a radio station that you have preset:

1. Set the Model 950 to Tuner.
2. Use the numeric keypad on the remote control to enter the 2-digit number of the preset that you want to hear.

The tuner frequency (and band if it is different then the previously tuned station) changes to the new station in the preset memory of the 950.

To change a preset radio station:

1. Tune to the new radio station you desire.
2. Press and hold the MEM button on the remote or the MEMORY button on the front panel.

The display will change to show the word Memory along with a flashing number.

3. Quickly enter the new preset/memory location (01 through 32) using the numeric keypad on the remote.

This replaces the previously memorized preset with your new selection. You have approximately 5 seconds to enter a number.

```
MEMORY 01-S STEREO
FM 106.7 MHz -10dB
```

Recording a Source

You can record from any input source available to the Model 950 when you have an audio or video recorder properly connected to the appropriate output jacks on the rear panel of the unit as outlined in the section titled "Connecting the Model 950" starting on page 13. You can not monitor the output from the recorder while the recording is in progress.

To record from the currently selected input source:

1. Prepare your recording device.

Follow the recommended procedures from the recorder manufacturer regarding settings in order to properly make a recording.

2. Set the device to the record mode and begin recording.

The source audio signals appear at the TAPE OUT and VCR-OUT audio jacks of the 950. If the source contains a video signal, the output appears at both the S-Video and Composite VCR-OUT video jacks.

Any digital source selected automatically appears at the DIGITAL OUTPUT jacks.

Note: If you change the input source during recording, you will record the signals from the newly selected input source from that point on.

Night Mode

Night Mode is a special feature of Dolby Digital that compensates for difficult listening situations by compressing the dynamic range of the speaker output. An example would be when you are watching a movie with a soundtrack that contains very loud passages and you don't want to disturb others in the house.

Information on the various compression options can be found on page 23-24. Night Mode compensation is only available when the surround mode of the selected input source is set to Dolby Digital or Dolby Digital EX.

To enable/disable Night Mode compensation:

1. Press the NIGHT button on the remote control.

The Night Mode selected during Input Configuration appears on the Front Panel Display and OSD under the currently selected input source.

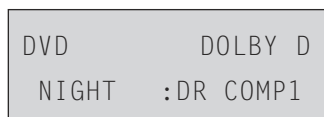

2. Use the < and > buttons to change the Night Mode setting.

The unit cycles through the options in the following sequence:

NO COMP→DR COMP1→DR COMP2→DR COMP 3→DR COMP4

The Night Mode menu will disappear automatically approximately 10 seconds after you make your selection.

Channel Trim

Channel Trim allows you to fine tune the channel levels to compensate for various soundtrack anomalies. For example, you may play a movie and find that the center (dialogue) channel is weak, making the movie hard to follow. Simply trimming the Center channel up a dB or two can fix the problem. Or another film may have substantially more bass than normal and trimming the Subwoofer channel down a dB or two may help balance the sound correctly.

This function can be accessed in two ways. You can press the TRIM button on the front panel or the remote control, or you can access this feature through the Main Menu. The Channel Trim menu is shown below.

Figure 7

| CHANNEL TRIM | | |
|--------------|---------------------|-------|
| > | LEFT FRONT | : 0dB |
| | CENTER FRONT | : 0dB |
| | RIGHT FRONT | : 0dB |
| | RIGHT SURR | : 0dB |
| | RIGHT BACK | : 0dB |
| | LEFT BACK | : 0dB |
| | LEFT SURR | : 0dB |
| | SUBWOOFER | : 0dB |
| | RETURN TO MAIN MENU | |

To adjust channel trim from the Main Menu:

1. While playing the program material with output that you wish to fine tune, press the MENU button to enter the Main Menu.

The Main Menu appears on the Front Panel Display and the OSD. The cursor on the OSD should be pointing to the Input Configuration menu and INPUT CONFIG appears on the Front Panel Display.

2. Press the √ button until the Channel Trim menu is selected.

The cursor on the OSD should be pointing to the Channel Trim menu and CHANNEL TRIM appears on the Front Panel Display.

3. Press SELECT to enter the Channel Trim menu.

The Channel Trim menu appears on the Front Panel Display and the OSD (see figure 7). The selected menu item should be LEFT FRONT.

4. Use the < and > buttons to adjust the channel trim.

You can adjust the selected channel trim level in 1dB steps across a range of -15dB to +10dB.

5. Press the √ button when you have finished making the channel trim adjustment.

If necessary, repeat steps 4 and 5 until you have completed setting the level for each speaker in your system. The sequence is as follows:

LEFT FRONT→CENTER FRONT→RIGHT FRONT→ RIGHT SURR(OUND)→RIGHT BACK (SURROUND)→LEFT BACK (SURROUND)→LEFT SURR(OUND)→SUBWOOFER

6. Press the √ button when you have finished making the channel trim adjustment to all the speakers in your system to select the Return to Main Menu option.

7. Press the SELECT or MENU button to return to the Main Menu, or press the MENU button twice to exit.

To adjust channel trim using the TRIM function:

1. Press the TRIM button on the front panel or the remote control.

The Front Panel Display and the OSD will show the following:



2. Use the < and > buttons to adjust the channel trim level.

You can adjust the selected channel level in 1dB steps across a range of -15dB to +10dB.

3. When you are finished adjusting the Channel Trim for the selected speaker, press TRIM again to cycle to the next channel.

The unit cycles through the speakers in the following sequence:

LEFT FRONT→CENTER FRONT→RIGHT FRONT→ RIGHT SURROUND→RIGHT BACK (SURROUND)→LEFT BACK (SURROUND)→LEFT SURROUND→SUBWOOFER

If necessary, repeat steps 2 and 3 until you have adjusted the channel trim of all the speakers in your system.

4. Press the TRIM button on the front panel or the remote control again to exit the Channel Trim function.

Remember to return any channel(s) that you have trimmed back to the original setting when you are done watching the particular program. If you find you are continually trimming the same channel(s) by the same amount for every film, you might want to consider re-calibrating the speaker levels as shown in the section, "Channel Calibration" on page 27. Set the levels for the channel(s) up or down by the amount you normally trim them.

Theater Compensation

Theater Compensation provides special equalization within any of the selected DSP modes. Most theatrical soundtracks are mixed on large dubbing stages for playback in large movie theaters. When these soundtracks are played back in your home, they may appear to have too much treble, sounding harsh and "bright." Theater Compensation modifies the audio signal to reduce these characteristics and make the soundtrack reproduction more natural sounding.

Theater Compensation can be accessed from the Main Menu or the T.COMP button on the remote.

To turn on Theater Compensation from the Main Menu:

1. Press the MENU button to enter the Main Menu.

The Main Menu appears on the Front Panel Display and the OSD. The cursor on the OSD should be pointing to the Input Configuration menu and INPUT CONFIG appears on the Front Panel Display.

2. Press the √ button until System Configuration is selected.

The cursor on the OSD should be pointing to the System Configuration menu and SYSTEM CONFIG appears on the Front Panel Display.

3. Press the SELECT button to enter the System Configuration menu.

The System Configuration menu appears on the Front Panel Display and the OSD (see figure 4 on page 28). The selected menu item should be FRONT DISTANCE.

4. Press the √ button until the Theater Compensation menu is selected.
5. Use the < and > buttons to choose between On and Off.
6. After making your selection, press the √ button twice to exit the Main Menu.

To turn on Theater Compensation using the T.COMP button:

1. Press the T.COMP button on the remote control.

The Front Panel Display and the OSD will show the following:



2. Press the T.COMP button again to toggle the between On and Off.

The Theater Compensation menu will disappear automatically approximately 15 seconds after you make your selection.

Dolby Pro Logic II Cinema and DTS-ES NEO:6 Cinema include a form of equalization of their own to address the same conditions. When using these modes the addition of Theater Compensation may cause excessive reduction of the upper frequencies. However, you may wish to experiment with different soundtracks to find what sounds best to you.

IMPORTANT NOTE: Theater Compensation is not recommended for Music modes, as the equalization added is not normally needed.

Multichannel Source Playback

Access to a 5.1 channel source connected to the Multichannel Inputs is accomplished by using the 6 Channel Direct mode. Examples of a 5.1 channel source would be a DVD-A or SACD multi-channel player.

Analog Bass Management

The Model 950 provides Analog Bass Management when 6 Channel Direct is selected. This function, which only applies to a source connected to the Multichannel inputs, is controlled via a small toggle switch on the rear panel of the Model 950 (see item 18 on page 9).

When the switch is in the Up position, the Analog Bass Management function is On, and the unit will provide an 80Hz crossover for the Left, Center, Right, Left Surround and Right Surround loudspeakers. Bass below 80Hz from all these channels will be sent into the subwoofer (.1) channel.

If the switch is set in the Down position, no crossover filtering occurs, providing the full bandwidth signal, including all bass information, to the speakers. However, all information below 80Hz is still summed and sent to the subwoofer output.

Note: Since in the Off position bass information is not removed from the speakers outputs, it is recommended that, unless you are absolutely sure your loudspeakers can handle the low frequency information, or that this function is supplied within your DVD player, you leave this switch in the Up/On position.

Once you have connected a component to the Multichannel inputs and set the Analog Bass Management, you should never have to change it, unless you get different speakers or a player that includes its own bass management.

To enter 6 Channel Direct mode:

1. Press the 6 CH button on the remote control.

The Model 950 is set to Bypass mode, circumventing any internal surround processing. The Front Panel Display and OSD display will read:

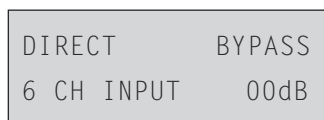

2. Press the 6 CH button again to turn off 6 Channel Direct mode, or use the Source selection buttons on the remote or front panel to select another source.

If you use the remote 6 CH button, the unit will return to the previously chosen source and settings.

Setting the Front Panel Display Brightness

This control sets the Front Panel Display brightness. The default display brightness is set to be easily visible in a normally lit room. If you prefer to dim the display, for example, during movie viewing in a darkened room, you can access the VFD Brightness setting from the System Configuration menu.

To set the Front Panel Display brightness:

1. Press the MENU button to enter the Main Menu.

The Main Menu appears on the Front Panel Display and the OSD. The cursor on the OSD should be pointing to the Input Configuration menu and INPUT CONFIG appears on the Front Panel Display.

2. Press the ∇ button until System Configuration is selected.

The cursor on the OSD should be pointing to the System Configuration menu and SYSTEM CONFIG appears on the Front Panel Display.

3. Press the SELECT button to enter the System Configuration menu.

The System Configuration menu appears on the Front Panel Display and the OSD (see figure 4 on page 28). The selected menu item should be FRONT DISTANCE.

4. Press the ∇ button until the VFD Brightness menu is selected.

5. Use the < and > buttons to choose between Full and Half.

6. After making your selection, press the ∇ button twice to exit the Main Menu.

Setting the On Screen Display (OSD) Time Out

This menu is used to set how long the ON SCREEN DISPLAY will remain visible after a button is pushed or setting is changed.

IMPORTANT NOTE: When the time is set to 0Sec the OSD will not appear.

To set the OSD Time Out:

1. Press the MENU button to enter the Main Menu.

The Main Menu appears on the Front Panel Display and the OSD. The cursor on the OSD should be pointing to the Input Configuration menu and INPUT CONFIG appears on the Front Panel Display.

2. Press the ∇ button until System Configuration is selected.

The cursor on the OSD should be pointing to the System Configuration menu and SYSTEM CONFIG appears on the Front Panel Display.

3. Press the SELECT button to enter the System Configuration menu.

The System Configuration menu appears on the Front Panel Display and the OSD (see figure 4 on page 28). The selected menu item should be FRONT DISTANCE.

4. Press the ∇ button until the OSD Time Out menu is selected.

5. Use the < and > buttons to cycle through the available options.

The following times appear as you scroll through them:

30Sec → 25Sec → 20Sec → 15Sec → 10sec → 5Sec → 3Sec → 0sSec

6. After making your selection, press the ∇ button twice to exit the Main Menu.

Sleep Timer

This option allows you set how long the unit will remain on before automatically shutting off. This mode can be accessed using the SLEEP button on the remote control, or from System Configuration menu.

To set the Sleep Timer from the Main Menu:

1. Press the MENU button to enter the Main Menu.

The Main Menu appears on the Front Panel Display and the OSD. The cursor on the OSD should be pointing to the Input Configuration menu and INPUT CONFIG appears on the Front Panel Display.

2. Press the ∇ button until System Configuration is selected.

The cursor on the OSD should be pointing to the System Configuration menu and SYSTEM CONFIG appears on the Front Panel Display.

3. Press the SELECT button to enter the System Configuration menu.

The System Configuration menu appears on the Front Panel Display and the OSD (see figure 4 on page 28). The selected menu item should be FRONT DISTANCE.

4. Press the ∇ button until the Sleep Time Set menu is selected.

5. Use the < and > buttons to cycle through the available choices.

The following times appear as you scroll through them:

60Min → 50Min → 40Min → 30Min → 20Min → 10Min → 5Min

6. After making your selection, Press the ∇ button twice to exit the Main Menu.

To set the Sleep Timer using the SLEEP button:

1. Press the SLEEP button on the remote control.

The Front Panel Display and the OSD will show the following:



2. Press the SLEEP button repeatedly to cycle through the time remaining options.

The following times appear as you press the SLEEP button:

60Min → 50Min → 40Min → 30Min → 20Min → 10Min → 5Min

The Sleep Timer menu will disappear automatically approximately 5 seconds after you make your selection.

Multi-zone Operation

The 950 allows you to send a stereo signal to a remote second zone. This signal must be amplified by an optional external power amplifier and sent into speakers in the remote zone. You can choose to feed any analog stereo source connected to the inputs of the 950 to the second zone and you can independently control its volume, regardless of what source has been chosen to play on the main system.

To turn on the Multi-zone system from the main listening area:

1. Press the MULTI button on the remote control.

The Multi-zone menu appears on the Front Panel Display and the OSD.

2. Use the < and > buttons to select On.

The yellow LED below the word MULTI on the front panel will illuminate indicating activation of the second stereo zone. Your selection will appear on the front Panel Display and the OSD.

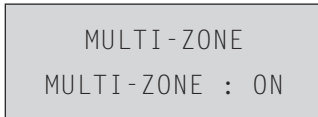

The low voltage ZONE output jack on the back of the 950 will be energized. Its output can be used to turn on the remote power amplifier (if it has such capability) or trigger another low voltage switchable device.

3. Press the MULTI button again to view the Input menu.
4. Use the < and > buttons to select which source signal will be sent through the ZONE OUT outputs to the second zone.

The Source choices appear as follows as you scroll through them:

DVD→VIDEO1→VIDEO2→VIDEO3→VCR→TUNER→
CD→TAPE→AUX1→AUX 2

You can scroll in either direction using the < and > buttons. Your selection will appear on the front Panel Display and the OSD.

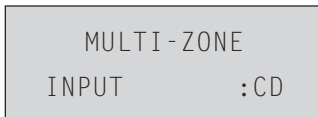

Only analog input sources can be used with the Multi-Zone system.

5. Press the MULTI button again to view the Mute menu.
6. Use the < and > buttons to select whether the Multi-zone mute function is On or Off.

Your selection will appear on the front Panel Display and the OSD.



The Multi-zone Mute function is unaffected by pressing the MUTE button on the remote control or 950 front panel.

7. Press the MULTI button again to view the Volume menu.
8. Use the < and > buttons to increase or decrease the volume level of the signal being sent to the second zone.

Your selection will appear on the front Panel Display and the OSD.



The range available is from -80dB to 10dB. Use caution as you can set a very high volume level and not be aware of it because of the distance between you and the second zone.

The Multi-zone volume level is unaffected by the VOL buttons on the remote control or 950 front panel main volume control.

9. Press the MULTI button again to exit the Multi-zone menu.

Audio from the source you selected will be heard through the speakers in the second zone.

The Multi-Zone system will remain on until it is specifically turned off. Thus, you may see the Mutli-Zone system indicator on even when the 950 is in the Standby mode with regard to the main room.

If you do not wish to use the Multi-Zone system to send sound to a second zone, you can use it as a separate audio-only record buss output that allows you to record one source while you listen to another.

Remote Control Setup and Operation

The Model 950 remote control is preprogrammed to operate over 1,000 audio and video components. Programming is accomplished by simply punching in a three digit code number that matches your equipment.

In addition to the Model 950 itself, the remote control can operate up to seven other audio and video devices in your home entertainment system. They are listed below:

- TVs, Monitors, Video/LCD Projectors
- VCRs, TV/VCR combination units
- Cable boxes, Internet set-top boxes
- Satellite receivers—DSS, PrimeStar, Dish, DBS, C-Band
- Audio receivers, Preamplifiers, Surround processors
- Compact disc players, Multi-Disc changers
- DVD, Laser disc players
- Cassette Tape Players, DAT, MiniDisc, Switchers, Lighting, Home Control Devices, and Line Doublers

For the best performance when operating your remote control, please follow the guidelines listed below.

- Remember to point the remote control toward the remote control sensor on the Model 950, not the TV screen. Place the 950 away from strong light such as direct sunlight or fluorescent light, which can prevent proper operation of the remote control.
- Using another remote control of a similar type or placing the Model 950 near equipment which also uses infrared control may cause operational interference.
- Do not put objects on the remote control. The buttons of the remote control may be pressed by mistake and drain the batteries.
- Make sure any doors, which may cover the front panel of the 950, do not have colored glass. Placing the unit behind such doors may prevent proper remote control operation.
- If there is any obstacle between the remote control and the remote control sensor, the remote control will not operate.

The remote control also has many advanced features that can add ease and enjoyment to the operation of your home entertainment system. After becoming familiar with the layout of the buttons on the remote (see page 10), follow the steps below to customize the remote for your particular setup.

Battery Installation

This remote control uses four AAA 1.5 V batteries (supplied). Please be sure to match the batteries with the (+) and (–) markings inside the battery compartment during installation.

To install batteries in the remote control:

1. Open the battery cover by pushing the latch toward the top of the remote and lifting up
2. Insert four (4) AAA batteries into the compartment, being careful to match the polarity shown on the diagram inside.
3. Slide the battery cover straight back in (toward the top of the remote) and push down until it snaps into place.

Note: Do not mix new and old batteries or different kinds of batteries. To avoid corrosion, remove the batteries if the remote control will not be used for one month or more. Remove dead batteries immediately to avoid damage from corrosion.

Under normal conditions the life of the batteries supplied is about six months, but this may vary depending on usage.

The remote control will retain its programmed memory for up to one year after the batteries are removed, and up to ten years after the batteries go “dead”.

Setup Using Preprogrammed Codes

Each of the Source Selection Buttons can be programmed to operate a particular audio or video component in your system. The AUD button is used exclusively for control of the Model 950. More detailed information can be found in the section “Operation.”

More than one setup code number may work with your device. You should test the functions for each of the code numbers that work with your device to determine the best one for your particular unit.

Note: Some devices, such as CD players and DVD Decks that do not have POWER buttons on their original remote controls, may not shut off during programming. For these devices, it may be necessary to first store the setup code number and then test functions like PLAY, STOP, etc., to determine if the correct number has been selected.

If your system has more than one VCR for example, any available Source button can be used to select that device. Use the steps below to program the remaining seven source buttons (TV, VCR, SAT, CBL, CD, DVD, and AUX) to program the remote control for your devices.

To program using Three Digit Codes:

1. Turn on the device you would like the remote control to operate, either manually or with its original remote control.
2. Find the three digit setup code number for your device from the tables on pages 41-44.
3. Press the corresponding Source button and the MUTE button on the remote control simultaneously.

The red LED and the selected Source button will illuminate.

Note: The selected button and LED will remain lit for approximately 10 seconds to indicate that the remote control is ready to be programmed. The following steps must be entered while they are lit. If the lights go out, simply press the Source and MUTE button again to re-enter the setup code.

Remote Control Setup and Operation

4. Point the remote control toward the device that was turned on in Step 1 and press in the first three-digit setup code number for that device using the number buttons (0-9) on the remote control.

The LED and selected Source button will blink and then stay lit after you enter a setup code.

Your device will turn off when the correct setup code number has been selected. If the device does not turn off, press in the next setup code number from the listing. The remote will remain in this programming mode as long as you continue to enter codes within 10 seconds of each other.

Continue entering setup code numbers until your device turns off, then proceed to Step 5.

Note: If you have tried all of the three digit setup code numbers listed for your device and it still did not turn off, please proceed to the Auto Search Method below to program your remote control.

5. Once your device turns off, press the Device Button selected in Step 3 once again to store the setup code number.

The LED and Source button will blink twice and then go out.

6. Test the remote control for your device. Try the POWER, CHANNEL UP and DOWN, VOLUME UP and DOWN buttons, etc.

If any of the buttons do not perform as they should, please repeat the setup from Step 1 using the next setup code number for your device.

Note: Some audio/video devices have separate buttons for POWER ON and POWER OFF. To operate these devices on the remote, press the corresponding Source button to turn the equipment ON and press the POWER button to turn the equipment OFF.

7. Please repeat the above steps to program the remote control for each of your other devices.

If none of the setup code numbers worked for your device during the standard setup procedure, or if the manufacturer or brand for your device is not listed in Setup Code Tables, use the steps below.

To program using Auto Search

1. Turn on the device you would like the remote control to operate, either manually or with its original remote control.
3. Press the corresponding Source button and the MUTE button on the remote control simultaneously.

The red LED and the selected Source button will illuminate.

Note: The selected button and LED will remain for approximately 10 seconds to indicate that the remote control is ready to be programmed. The following steps must be entered while they are lit. If the lights go out, simply press the Source and MUTE button again to re-enter the setup code.

3. Point the remote control toward the device and press the CHANNEL UP button on the remote control.

Each press of the CHANNEL UP button sends the signal for one setup code number. The LED and Source button will blink each time you press the CHANNEL UP button. Keeping the CHANNEL UP button pressed quickly scans through the setup code numbers.

Release the CHANNEL UP button as soon as the device turns off. Confirm that you have the correct code by pressing the MUTE button on the remote. You should be able to turn your device on and off with this button.

If you pass the correct setup code number, you can return to it by pressing the CHANNEL DOWN button, one number at a time, until your device turns back on.

Note: During programming, the signal for POWER ON and POWER OFF is located on the MUTE button. For devices that use separate POWER ON and POWER OFF buttons, pressing the MUTE button on the remote control during programming will only turn the device OFF.

4. Once the correct code is confirmed, press the Source button to store the setup code number.

The LED and Source button will blink twice and then go out.

5. Test the remote control for your device. Try the POWER, CHANNEL UP and DOWN, VOLUME UP and DOWN buttons, etc.

If any of the buttons do not perform as they should, please repeat the setup from Step 1 using the next setup code number for your device.

Note: Some audio/video devices have separate buttons for POWER ON and POWER OFF. To operate these devices on the remote, press the corresponding DEVICE Button to turn the equipment ON and press the POWER button to turn the equipment OFF.

6. Please repeat the above steps to program the remote control for each of your other devices.

To display the stored three digit setup code number for a device:

1. Press the corresponding Source button and the MUTE button on the remote control simultaneously.

The red LED and the selected Source button will illuminate.

2. Press the T/V button.

The LED and Source button will quickly flash the three digit setup code number, pausing between numerals, that was stored for your device in that mode. The number zero (0) is indicated by ten flashes.

3. Please write your setup code numbers in the chart below, for future reference.

Set-Up Code Numbers:

| | |
|-----|-----|
| CD | TV |
| DVD | VCR |
| AUX | CBL |
| SAT | |

Operation

After you have programmed the remote control for your equipment, use the following procedures to operate the components of your home entertainment system:

To operate a system component that you have programmed:

1. Press the Source button that you wish to operate
For example, to operate a TV, press the TV button; to operate a VCR, press the VCR button, etc.
2. Aim the remote control at the device and press the POWER button to turn on the device.
3. Press the buttons that send out the commands you desire.

Note: Some audio/video devices have separate buttons for POWER ON and POWER OFF. To operate these devices on the remote, press the corresponding DEVICE Button to turn the equipment ON and press the POWER button to turn the equipment OFF.

Please try all the functions of this remote control with your equipment. The most common functions are labeled on the remote. However, some of the secondary functions might be stored under a button that has a different name from the one on your original remote control.

Source Selection Buttons

Pressing a Source button at the top of the remote control performs the following functions:

- If the Model 950 is in Standby mode, powers up the unit.
- Changes the Source input mode on the remote control.

Backlighting

Pressing the LIGHT button illuminates all the buttons on the remote control for 7 seconds. The backlight is extended an additional 7 seconds with any button press while the backlight is on.

Volume Control Punch Through

You can program the remote control so that the Model 950 VOLUME UP, VOLUME DOWN and MUTE functions will operate while the remote is set to control another source.

For example, using the Punch Through function, you can raise, lower or mute the volume of the preamp/processor while the remote control is in the SAT mode.

Note: When this feature is active, the AUDIO or TV VOLUME and MUTE will override any existing volume controls in that mode.

To program the remote for volume control Punch Through:

1. Press the Source button of the device you wish to program for volume control Punch Through and the MUTE button simultaneously
The red LED and the selected Source button will illuminate.
2. Press the VOLUME UP button.
The red LED and the selected Source button will blink.

3. Press the AUD button to enable volume control of the Model 950.

OR

Press the TV button to enable volume control of the television.

The LED and Source button will blink twice and then go out.

The VOLUME UP, VOLUME DOWN and MUTE buttons will now control the Punch Through device while another Source is selected.

To turn off volume control Punch Through for a source:

1. Press the Source button of the device you wish to remove the Punch Through program from and the MUTE button simultaneously
The red LED and the selected Source button will illuminate.
2. Press the VOLUME UP button.
The red LED and the selected Source button will blink.
3. Press the Source button again.

The Model 950 Punch Through function is now turned off. The VOLUME and MUTE of the original device will operate on the remote control.

Macro Buttons

The four Macro buttons (M1-M4) are used to store and send a sequence of up to 10 commands each. They can be programmed in the AUD mode, but can also be accessed in other modes. Macros can be used to turn components on or off or select favorite channels.

Note: The MUTE button is used to designate POWER commands during Macro Button programming. See the Example: Memory Button Programming for further description.

To program a macro button:

1. Press AUD and MUTE buttons simultaneously.
The red LED and the AUD button remain lit.
2. Press the Macro button you wish to program.
3. Press up to 10 commands you would like to include in the macro sequence.
Pressing a Device button to change modes is counted as one command.
4. Press the CHANNEL UP button to store the commands.
The red LED and the AUD button will blink twice to confirm the program and then turn off.

The Macro button will now send the sequence of commands you programmed when pressed.

To erase a Macro sequence:

1. Press AUD and MUTE buttons simultaneously.
The red LED and the AUD button remain lit.
2. Press the Macro button that you wish to erase.
3. Press the CHANNEL UP button to store the commands.
The red LED and the AUD button will blink twice to confirm the program and then turn off.

The stored sequence is now erased from the Macro button.

Note: Any previously stored commands on a Memory Button will be erased when new commands are stored on the same Memory Button.

Example of Programming a Macro Sequence:

To program the M1 button in the AUD mode to turn on the Audio receiver, turn on the TV and turn on the VCR.

1. Press AUD and MUTE buttons simultaneously.

The red LED and the AUD button remain lit.

2. Press the M1 button.
3. Press the following buttons:

Press the Power button to select the Audio Power command.
Press the TV Device button to select the TV mode.
Press the Power button to select the TV Power command.
Press the VCR Device button to select the VCR mode.
Press the Power button to select the VCR Power command.

4. Press the CHANNEL UP button.

The red LED and the Device button will blink twice to confirm the program and then turn off.

Note: Each insertion of a Device Button adds a 1/2 second delay to the command sequence. It can take up to 10 seconds to send out 10 commands from a macro button. Please continue to point the remote control at the device(s) until all the commands on the Macro button have been sent out. This will ensure that all the commands are received by the device(s).

Learning Commands from Another Remote

The Model 950's remote control allows you to transfer a command from a button on your original equipment remote control to a button on the 950's remote control. New commands can be taught to any button in the DVD, VCR, CD, CBL, AUX, SAT and TV modes except the 8 Source buttons.

The remote control provides distinct visual feedback with the Status LED, located at the top left of the remote control, and with the Source buttons. The LED operates in three colors (red, orange and green). The Device buttons have a red color LED behind them. These LEDs will assist you in programming the learning of the remote control.

Learning a New Command

Select a Source mode in which you would like to teach the new command. For example, if you wanted to learn a new command to the MENU button in the SAT mode on the remote, you would select the SAT Source button and then use the instructions below to teach the new command to the MENU button.

To learn a new command from another remote control:

1. Press a Source button and the SEL/PLAY buttons simultaneously until the orange LED and the Device button turn on and remain lit.
2. On the remote control, press the button that is to be taught the new command.

The orange Status LED will begin to flash continuously. The Device LED will turn off.

3. On the source remote control (original remote control), press and hold the button for the command to be learned until the Status LED on the remote turns green. Release the button on the source remote control.

Both remote controls must be next to each other with the IR emitters face to face.

4. Press the button on the source remote control, once again to verify that the new command has been learned correctly. The Status LED will flash green twice and then turn to a steady orange color indicating that the programming was successful. The Source button will light.

Repeat Steps 2 through 4 for any other buttons to be taught in the Device mode selected in Step 1. Once you have completed learning new commands to buttons in the selected Source mode, proceed to Step 5.

5. To save the learned commands, press and hold the Source and SEL/PLAY buttons simultaneously until the orange Status LED flashes twice.

The Source button light will turn off.

Please repeat for any other Source modes starting from Step 1.

To erase a learned command from a button:

1. Press the Source button and SEL buttons simultaneously until the orange Status LED and the Device button turn on and remain lit.
2. On the remote control, press the button that is to be erased.

The orange Status LED will flash continuously and the Device button will turn off.

3. Press the Light button.

The green status LED will flash twice, then turn to a steady orange. The Device button will turn on.

Repeat from Step 2 for any other buttons to be erased in the selected Source mode.

4. To exit, press and hold the Source button and the SEL/PLAY button simultaneously once again. The orange Status LED will flash twice and then turn off. The Device button will turn off.

To erase all the learned commands in one device mode:

1. Press the Source button and SEL buttons simultaneously until the orange Status LED and the Device button turn on and remain lit.
2. Press the LIGHT button until the red Status LED flashes five times and then flash green twice.

The Device button will turn off. The Status LED will go to a constant orange indicating that all the learned information on buttons in the Device mode have been erased. The Device button will turn on.

3. To exit, press and hold the Source button and the SEL/PLAY button simultaneously once again. The orange Status LED will flash twice and then turn off. The Device button will turn off.

To erase all the learned commands in all device modes:

Note: This procedure will erase all learned commands on all buttons in the CD, TV, DVD, SAT, CBL, VCR and AUX Source modes.

- Press and hold the TV Source button and the LIGHT button simultaneously.

The red Status LED will flash continuously. The Status LED will then flash green once, orange once then turn off, indicating that all of the learned commands on all of the device modes on the remote control have been erased.

Setup Codes

The following tables contain the setup codes for most brands of audio and video components.

CABLE

| <i>Manufacturer/Brand</i> | <i>Setup Code Number</i> |
|---------------------------|--------------------------|
| AMERICAST | 005 |
| JERROLD | 006 007 |
| MITSUBISHI | 014 |
| PHILIPS | 011 012 |
| PIONEER | 001 002 003 |
| SCIENTIFIC ATLANTA | 004 |
| SONY | 013 |
| TOCOM | 010 |
| ZENITH | 008 009 |

SAT

| <i>Manufacturer/Brand</i> | <i>Setup Code Number</i> |
|---------------------------|--------------------------|
| ALPHASTAR | 007 |
| ECHOSTAR | 006 |
| GE | 001 |
| HITACHI | 011 012 |
| HUGHES | 003 |
| PANASONIC | 013 |
| PRIMESTAR | 002 005 |
| RCA | 001 |
| SONY | 004 |
| TOSHIBA | 008 |
| UNIDEN | 009 010 |

TV

| <i>Manufacturer/Brand</i> | <i>Setup Code Number</i> |
|---------------------------|---------------------------------|
| A MARK | 112 |
| ADMIRAL | 072 081 161 |
| AKAI | 001 146 |
| AMPRO | 073 167 |
| ANAM | 043 056 080 104 108 112 118 121 |
| AOC | 001 004 112 |
| AUDIOVOX | 076 103 |
| CANDLE | 001 003 004 |
| CETRONIC | 043 |
| CITIZEN | 001 003 004 101 143 |
| CLASSIC | 043 |
| CONCERTO | 004 |
| CONTEC | 043 |
| CORONADO | 143 |

TV (continued)

| <i>Manufacturer/Brand</i> | <i>Setup Code Number</i> |
|---------------------------|---|
| CROWN | 143 |
| CURTIS MATHES | 001 101 004 143 |
| CXC | 043 |
| DAEWOO | 076 103 004 114 127 143 |
| DAYTRON | 004 143 |
| DYNASTY | 043 |
| DYNATECH | 062 |
| ELECTROHOME | 024 143 |
| EMERSON | 028 048 043 155 005 096 076 001 004 143 151 153 154 |
| FISHER | 007 057 |
| FUNAI | 028 043 |
| FUTURETECH | 043 |
| GE | 160 161 144 004 130 073 008 034 056 074 155 |
| GOLDSTAR | 004 106 110 112 113 119 127 143 |
| HALL MARK | 004 |
| HITACHI | 163 007 004 010 011 012 023 075 143 158 |
| INFINITY | 164 |
| JBL | 164 |
| JCP | 001 |
| JCPENNY | 004 008 024 030 065 101 143 160 |
| JVC | 038 070 083 034 |
| KENWOOD | 001 070 |
| KLOSS | 059 |
| KTV | 043 143 154 |
| LODGENET | 072 |
| LOGIK | 072 |
| LUXMAN | 004 |
| LXI | 007 015 052 081 160 164 |
| MAGNAVOX | 164 059 001 003 004 022 060 061 063 064 127 |
| MARANTZ | 001 164 |
| MATSUI | 164 |
| MEMOREX | 007 072 004 |
| MGA | 001 004 024 042 |
| MITSUBISHI | 004 024 040 042 109 146 191 |
| MTC | 001 004 062 101 |
| NAD | 015 025 |
| NEC | 001 130 134 040 024 056 019 |
| NIKEI | 043 |
| ONKING | 043 |
| ONWA | 043 |
| OPTONICA | 019 081 |
| PANASONIC | 034 056 080 164 |
| PHILCO | 001 003 024 056 059 060 063 064 127 143 164 004 |
| PHILIPS | 164 093 038 005 001 003 004 059 |

| TV (continued) | |
|---------------------------|---|
| <i>Manufacturer/Brand</i> | <i>Setup Code Number</i> |
| PIONEER | 025 135 004 018 023 176 |
| PORTLAND | 004 143 |
| PROSCAN | 144 160 161 167 |
| PROTON | 171 173 004 143 |
| QUASAR | 034 056 |
| RADIO SHACK | 004 019 127 143 |
| RCA | 160 161 065 156 144 001 004 023 024 056 074 152 |
| REALISTIC | 007 019 |
| RUNCO | 072 169 |
| SAMPO | 001 004 |
| SAMSUNG | 004 101 127 133 143 160 |
| SANYO | 007 057 082 |
| SCOTT | 004 028 043 048 143 |
| SEARS | 094 015 028 030 004 007 057 082 143 160 |
| SHARP | 019 081 028 014 004 022 143 175 |
| SIGNATURE | 072 |
| SONY | 070 085 139 126 |
| SOUNDESIGN | 028 004 003 043 |
| SPECTRICON | 112 |
| SSS | 004 043 |
| SYLVANIA | 001 003 059 060 063 064 164 160 127 |
| SYMPHONICS | 052 |
| TANDY | 081 |
| TATUNG | 056 062 |
| TECHNICS | 034 080 |
| TECHWOOD | 004 |
| TEKNIKA | 003 004 024 028 043 072 101 143 |
| TELERENT | 072 |
| TERA | 172 |
| TMK | 004 |
| TOSHIBA | 015 030 040 062 101 |
| TOTEVISION | 143 |
| UNIVERSAL | 008 |
| VIDEO CONCEPTS | 146 |
| VIDIKRON | 174 |
| VIDTECH | 004 |
| VORK | 004 |
| WARDS | 004 008 009 019 028 060 061 063 064 072 074 164 |
| WESTING HOUSE | 076 |
| YAMAHA | 001 004 |
| YUPITERU | 043 |
| ZENITH | 072 073 095 103 |
| ZONDA | 112 |

| VCR | |
|---------------------------|---|
| <i>Manufacturer/Brand</i> | <i>Setup Code Number</i> |
| AIWA | 034 161 |
| AKAI | 043 046 124 142 146 |
| AMPRO | 072 |
| ANAM | 031 103 |
| AUDIO DYNAMICS | 012 023 043 |
| BROKSONIC | 035 037 129 |
| CANON | 028 031 |
| CAPEHART | 108 |
| CRAIG | 001 040 135 |
| CUIRTIS MATHES | 031 041 |
| DAEWOO | 117 005 116 010 017 108 |
| DAYTRON | 108 |
| DBX | 012 023 043 |
| DYNATECH | 034 053 |
| ELECTROHOME | 059 |
| EMERSON | 006 029 035 153 017 025 005 116 027 031 034 036 037 046 101 129 131 138 |
| FISHER | 001 008 009 010 |
| FUNAI | 034 |
| GE | 031 063 072 107 109 144 147 |
| GO VIDEO | 132 136 151 |
| GOLDSTAR | 004 012 020 101 123 |
| HARMAN KARDON | 012 045 |
| HITACHI | 026 150 018 034 043 063 137 |
| INSTANTREPLAY | 031 |
| JCL | 031 |
| JCPENNY | 004 012 040 101 |
| JENSEN | 043 |
| JVC | 031 043 048 012 055 060 130 150 152 |
| KENWOOD | 014 034 048 047 |
| LLOYD | 034 |
| LXI | 034 001 004 009 017 101 |
| MAGIN | 040 |
| MAGNAVOX | 067 031 034 041 068 154 164 |
| MARANTZ | 067 069 012 031 |
| MARTA | 101 |
| MATSUI | 027 |
| MEI | 031 |
| MEMOREX | 040 101 001 010 014 031 034 053 072 134 139 |
| MGA | 045 046 059 |
| MINOLTA | 004 020 |
| mitsubishi | 059 061 004 020 046 051 142 |
| MTC | 034 040 |
| MULTITECH | 024 034 |
| NEC | 012 023 043 048 |

VCR (continued)

| <i>Manufacturer/Brand</i> | <i>Setup Code Number</i> |
|---------------------------|---|
| NORDMENDE | 043 |
| OPTONICA | 053 054 |
| PANASONIC | 031 070 133 140 |
| PENTAX | 004 020 031 063 |
| PHILCO | 031 034 067 |
| PHILIPS | 031 067 034 054 101 |
| PILOT | 101 |
| PIONEER | 004 021 048 |
| PORTLAND | 108 |
| PULSAR | 072 |
| QUARTZ | 014 |
| RADIO SHACK | 101 123 |
| RCA | 144 147 107 109 031 004 020 034 040 041 140 158 |
| REALISTIC | 001 008 010 014 031 034 040 053 054 101 |
| RICO | 058 |
| RUNCO | 072 |
| SALORA | 014 |
| SAMSUNG | 017 040 107 109 113 115 124 |
| SANSUI | 043 048 135 |
| SANYO | 001 010 040 014 134 |
| SCOTT | 017 037 129 131 |
| SEARS | 017 081 001 004 008 009 010 014 020 101 |
| SHARP | 053 031 054 165 |
| SHINTOM | 024 |
| SONY | 056 057 058 001 009 031 052 053 155 002 |
| SOUNDESIGN | 034 |
| STS | 004 |
| SYLVANIA | 031 034 059 067 |
| SYMPHONIC | 034 |
| TANDY | 010 034 |
| TATUNG | 043 |
| TEAC | 034 043 |
| TECHNICS | 031 070 |
| TEKNIKA | 031 034 101 |
| THOMAS | 034 |
| TMK | 006 |
| TOSHIBA | 017 131 004 008 059 082 150 047 |
| TOTEVISION | 040 101 |
| UNITECH | 040 |
| VECTOR RESEARCH | 012 |
| VICTOR | 048 |
| VIDEO CONCEPTS | 012 034 046 141 |
| VIDEOSONIC | 040 |
| WARDS | 001 004 017 024 031 034 040 053 054 131 |

VCR (continued)

| <i>Manufacturer/Brand</i> | <i>Setup Code Number</i> |
|---------------------------|---------------------------------|
| WESTINGHOUSE | 005 |
| YAMAHA | 012 034 043 |
| ZENITH | 072 034 048 056 058 080 101 153 |

DVD

| <i>Manufacturer/Brand</i> | <i>Setup Code Number</i> |
|---------------------------|--------------------------|
| DENON | 014 |
| GE | 005 006 |
| JVC | 012 |
| LG | 074 057 |
| MAGNAVOX | 013 |
| MITSUBISHI | 002 |
| ONKYO | 017 |
| PANASONIC | 003 |
| PHILIPS | 013 |
| PIONEER | 004 |
| PROSCAN | 005 006 |
| RCA | 005 006 |
| SAMSUNG | 011 015 |
| SHERWOOD | 001 057 074 112 114 116 |
| SONY | 007 |
| THOMPSON | 005 006 |
| TOSHIBA | 008 |
| VIETA | 116 |
| YAMAHA | 009 |
| ZENITH | 074 057 |

LD

| <i>Manufacturer/Brand</i> | <i>Setup Code Number</i> |
|---------------------------|--------------------------|
| DENON | 030 |
| GOLDSTAR | 027 |
| KENWOOD | 025 |
| MAGNAVOX | 026 |
| OPTIMUS | 032 |
| PANASONIC | 021 |
| PHILIPS | 026 |
| PIONEER | 020 034 |
| RCA | 031 |
| REALISTIC | 032 |
| SAMSUNG | 023 029 |
| SHARP | 025 028 |
| SONY | 022 |
| TECHNICS | 021 |
| TOSHIBA | 025 |
| YAMAHA | 033 |

| CD | |
|--------------------|-----------------------------|
| Manufacturer/Brand | Setup Code Number |
| ADCOM | 062 |
| AIWA | 187 170 089 |
| AKAI | 202 |
| AUDIO TECHNICA | 046 |
| CARVER | 167 041 135 138 139 050 203 |
| DENON | 205 226 |
| FISHER | 016 |
| H/K | 047 033 208 046 |
| JVC | 136 163 004 |
| KENWOOD | 007 055 023 137 016 |
| MARANTZ | 044 041 |
| MONDIAL | 147 |
| NAD | 215 005 178 |
| NAKAMICHI | 218 |
| NIKKO | 046 |
| ONKYO | 038 168 030 062 169 |
| PANASONIC | 068 172 |
| PHILIPS | 041 |
| PIONEER | 010 020 174 |
| RCA | 017 021 |
| REALISTIC | 187 |
| SANSUI | 171 |
| SHARP | 051 173 |
| SHERWOOD | 001 166 096 051 |
| SONY | 225 097 126 133 |
| TEAC | 079 140 |
| TECHNICS | 068 008 172 |
| VICTOR | 004 |
| YAMAHA | 012 186 183 046 |

Care and Maintenance

Cleaning

When the unit becomes dirty, wipe it with a clean, soft, dry cloth. If necessary, first wipe the surface with a soft cloth slightly dampened with mild soapy water, then with a fresh cloth dampened with clean water. Wipe dry immediately with a dry cloth. NEVER use benzene, thinner, alcohol or any other volatile cleaning agent. Do not use abrasive cleaners, as they may damage the finish of the metal parts. Avoid spraying insecticide, waxes, polishing agents, or any aerosol product near the unit.

When You Are Away

If you will not be using your home theater system for an extended period of time, it is always a good idea to turn the unit off using the Power Switch on the rear panel of the Model 950. This will prevent the automatic turn on circuits from accidentally turning the system on during your absence.

Troubleshooting

Your new Model 950 is designed to provide years of trouble free operation. However, the complexity of today's sophisticated home theater systems means that you might encounter an occasional problem with your system involving the Model 950. Listed below are some of the more common issues you could encounter. For additional hints on using the Model 950 or resolving problems we suggest that you look at the Model 950 section of our website at www.outlawaudio.com, or enter the Model 950 Section of our Outlaw Saloon. If your problem persists, please contact us via e-mail at customer.service@outlawaudio.com, or call us at 866-OUTLAWS (688-5297) or 866-OUTLAWA (688-5292).

System Reset

In rare cases the Model 950's internal processor may freeze or lock-up causing abnormal operation. This is common to all micro-processor controlled devices when the unit is subject to excessive static discharge, AC line noise, or power spikes.

In most cases it is easy to solve this problem by simply unplugging the Model 950 from its AC power source for about five minutes. After waiting, reconnect the power cord and turn the unit on. If the unit functions normally, no further action is needed.

In the event that the unit still does not operate properly, it may be necessary to manually reset the processor. Note, however, that when the processor is reset you will lose all settings including digital audio assignments, surround mode settings, speaker configurations, tuner presets and any other memory items. For this reason we strongly recommend that you record these settings on the

chart provided on page 18 of this manual so that it is easy to restore them after resetting the processor.

To reset the unit you must first remove the volume control knob on the front panel by grasping it and gently pulling the knob straight out towards you. When the knob is removed you will see a very small hole in the black aluminum front panel at the "nine o'clock" position. With the unit on, use a toothpick or unfolded paper clip to gently press the button behind the opening. Hold the button for a second and then release it. This should reset the system.

Replace the volume control knob, being careful to line up the flat surface on the control shaft with the matching flat surface on the inside of the knob. Push the knob straight on to the shaft until it is firmly seated.

If the manual reset does not solve the problem, contact Outlaw Audio for further advice.

| Symptom | Possible Cause | Solution Options |
|--|---|---|
| Unit does not turn on when remote or front panel buttons are pressed | No AC Power | Make certain AC power cord is plugged into a live outlet Make certain rear panel power switch is ON |
| No sound from digital audio source | Input not properly selected | Make certain the correct digital input is associated to the source |
| No DTS when a DVD is playing | Incorrect bitstream output from DVD player | Check the DVD player's setup menus to make certain DTS output is selected Check the disc menu to make certain DTS is selected |
| No sound from rear surround speakers | Incorrect speaker configuration | Check Speaker Config menu to make certain that "BS(LB)" or "LB/RB" is selected for Surr Rear |
| Intermittent buzzing in tuner | Interference from local sources | Move or relocate the antenna Move the antenna or unit away from computers, fluorescent or neon lights, or appliances with motors |
| Unit does not respond to remote commands | Low remote battery power Remote set to different device Remote sensor is obscured | Change the batteries Press the AUD button to make sure the remote is outputting 950 codes Make certain the front-panel remote sensor is visible or connect a remote sensor |
| No sound from one or more channels | Poor connections Incorrect surround mode Incorrect speaker configuration | Check interconnects to the amplifier and connections from the amplifier to the speakers Check surround mode to make certain it provides output to all speakers Check Speaker Config menu to make certain all speakers are set to Small or Large |

Model 950 Specifications

Preamplifier Analog Section

| | |
|--|--|
| Input Impedance | 26K Ω |
| Output Impedance (Main-RCA) | <600 Ω |
| Rated Input | 2.0Vrms |
| Maximum Input | 3.0Vrms |
| Rated Output (100k Ω load) | 1.5Vrms |
| Minimum Load | 5k Ω |
| Maximum Output | 6.3Vrms |
| Volume Range | |
| Main | -80dB to +10.0 dB (1dB resolution) |
| Zone | -80dB to +10.0 dB (1dB resolution) |
| Bass Management | |
| High-Pass Slope (Small Speaker Setting) | Crossover Frequency (Adjustable 40/60/80/100/120/150Hz) 12 dB/octave (2nd order) |
| Low-Pass Slope (Subwoofer) | 24 dB/octave (4th order), 40-150Hz as above |
| Tone Control | |
| Bass Center Frequency/Range | 30Hz / \pm 6dB |
| Treble Center Frequency/Range | 10KHz / \pm 6db |
| Channel Separation (at 1kHz) | 82dB |
| Crosstalk Between Inputs (at 1kHz) | 86dB |

Preamplifier Digital Section

| | |
|-------------------------------------|------------------------------|
| Frequency Response | |
| Direct Inputs | 10 Hz to 20 kHz +0 / -0.2 dB |
| Analog-DSP Inputs | 10 Hz to 20 kHz +0 / -0.5 dB |
| Digital Inputs | 10 Hz to 20 kHz +0 / -0.4 dB |
| THD+N (at Rated Input & Output) | |
| 6-Channel Direct Inputs | 0.0035% (80 kHz BW) |
| Analog-Direct Inputs | 0.0035% (AES17 filter) |
| Analog-DSP Inputs | 0.005% (AES17 filter) |
| Digital Inputs | 0.006% (80 kHz BW) |
| IMD (CCIF) @ 15 kHz & 16 kHz | |
| 6-Channel S/E Inputs | 0.003% |
| All Other Analog Inputs | 0.002% |
| Digital Inputs | 0.005% |
| S/N Ratio (ref. 2.0Vrms A-weighted) | |
| All Direct Inputs | 101dB |
| Analog-DSP Inputs | 98dB |
| Digital Inputs | 100dB |

Zone 2 Section

| | |
|-------------------------------------|------------------|
| Frequency Response and Bandwidth | |
| THD+N (at Rated Input & Output) | 0.01% (80kHz BW) |
| IMD (CCIF at 15kHz & 1 kHz) | 0.01% |
| S/N Ratio (ref. 2.0Vrms A-weighted) | 97dB |

FM Tuner Section

| | |
|------------------------------|---------------------------|
| Sensitivity | |
| IHF | 10dB μ typ. |
| 50dB S/N | 13dB μ typ. |
| S/N Ratio | |
| Mono | 75dB typ. |
| Stereo | 69dB typ. |
| Distortion | |
| Mono | 0.2% typ. |
| Stereo | 0.3% typ. |
| Stereo Separation | 40dB typ. |
| Adjacent Channel Selectivity | 70dB \pm 400kHz |
| Frequency Response | 20 Hz to 15 kHz \pm 1dB |

AM Tuner Section

| | |
|---------------------------------------|-------------|
| Sensitivity (20dB S/N) | 200 μ V |
| S/N | 50dB |
| Distortion | 0.7% |
| One Signal Selectivity (\pm 10kHz) | 20 dB |

Video Section

| | |
|---------------------|------------|
| Bandwidth | |
| Composite & S-Video | 6 MHz -3dB |
| Component Green | 45MHz -3dB |
| Component Red | 45MHz -3dB |
| Component Blue | 45MHz -3dB |

All video inputs and outputs are 75 ohms, 1.5 Vp-p. Component inputs and outputs work with any Standard requiring ultra-wide bandwidth including Component-RGB, HDTV, line doublers, quadruplers, and scalars.

Digital Audio

| | |
|--|---|
| All digital audio inputs and outputs are to S/PDIF electrical (75 ohms, 0.5 Vp-p), S/PDIF optical (Toslink), or AES / EBU (110 ohms, 5 Vp-p) standards as appropriate. | |
| Processor | Crystal CS49326 |
| Audio Converters | |
| Digital Audio Inputs | CS8415A Digital Audio Interface up to 96kHz |
| Analog to Digital | CS5360 up to 24-bit/48kHz |
| Digital to Analog | CS4396 up to 24-bit/192kHz |

General

| | |
|----------------------------|---|
| Supply Voltage | 105-130V, 60Hz only |
| Power Consumption | 45W |
| Fuse Rating | 1.0A slow-blow 5x20 mm, 2.0A slow-blow 5x20mm |
| Dimensions | |
| Width | 17.12 inches / 435 mm |
| Height | 4.6 inches / 117 mm |
| Depth | 14.76 inches / 375 mm |
| Weight | 17.6 lbs. / 8 kg |
| Trigger Outputs 1, 2(Zone) | Sequential Delay 50 mA @ 12 VDC |

Outlaw Audio Limited Warranty

This warranty protects the owner of the Outlaw Model 950 Preamp/Processor (the PRODUCT) for five (5) years from the date of purchase.

This warranty covers all defects in material and workmanship with the following specific exceptions. These are:

- Damage caused by improper installation or adjustment
- Damage caused by accident, unreasonable use or neglect
- Damage from failure to follow instructions contained in this Owner's Manual
- Damage from the performance of repairs by someone not authorized by Outlaw Audio
- Any unit on which the serial number has been effaced, modified, or removed
- Damage occurring during shipment
- Units which have been altered or modified in design, appearance or construction

This warranty covers only the actual defects within the PRODUCT itself. IT DOES NOT cover costs of installation in (or removal from) a fixed installation, or normal set-up, claims based on any misrepresentation by the seller, or performance variations resulting from installation related circumstances such as signal quality, AC power or incompatibilities with speakers and/or other system components.

During the warranty period, Outlaw Audio will, at its option, either repair the defect, or replace the defective product, or the defective parts, or components thereof at no charge to the owner for parts and labor covered by this warranty. If necessary repairs are not covered by this warranty, or if a unit is examined which is not in need of repair, you will be charged for the repairs and/or the examination. If non-warranted repairs are needed, we will notify you of the estimated cost and ask for your authorization to perform said repairs.

You must pay shipping charges incurred in getting your Product to the factory. We will pay the return shipping charges if the repairs are covered by the warranty. Please save the original shipping cartons as the unit MUST

be returned in the original carton and packing. (Replacement cartons are available at a modest charge.)

If your product needs service, please call Outlaw Audio Inc. at 866-OUTLAWS (688-5297) or 866-OUTLAWA (688-5292).

You will need to present the original bill of sale to establish the date of purchase. In the event that the proof of purchase cannot be established with the original receipt, the warranty period shall be determined by the earliest date of manufacture shown on the unit, provided that the serial number label has not been altered in any manner, or by our records relating to that serial number.

In the event that you wish to return your Outlaw Product back to us, for any reason, please call to arrange for a Return Authorization Number. This will insure that your problem is discussed with a service technician who will determine if there is a quick solution to your problem.

Outlaw Audio shall not be liable for, in any way responsible for, any incidental or consequential damages of any kind. Some states do not allow limitations on how long an implied warranty lasts and/or do not allow the exclusion of incidental or consequential damages, therefore, the limitations and exclusions stated herein may not apply to you. This warranty gives you specific legal rights; and you may also have other rights which vary from state to state.

THERE ARE NO WARRANTIES GIVEN BY OUTLAW AUDIO WHICH EXTEND BEYOND THE DESCRIPTION GIVEN HEREIN. ANY IMPLIED WARRANTIES OF FITNESS FOR PURPOSE SOLD, MERCHANTABILITY, DESCRIPTION, QUALITY OR ANY OTHER MATTERS ARE LIMITED TO THE TERMS OF THE EXPRESSED LIMITED WARRANTY STATED HEREIN.

Products are sold on the basis of specifications applicable at the time of sales. Outlaw Audio shall have no obligation to modify products once they have been sold.

This warranty is applicable only in the United States.

For applicability in other countries, please call Outlaw Audio, Inc.



Free Manuals Download Website

<http://myh66.com>

<http://usermanuals.us>

<http://www.somanuals.com>

<http://www.4manuals.cc>

<http://www.manual-lib.com>

<http://www.404manual.com>

<http://www.luxmanual.com>

<http://aubethermostatmanual.com>

Golf course search by state

<http://golfingnear.com>

Email search by domain

<http://emailbydomain.com>

Auto manuals search

<http://auto.somanuals.com>

TV manuals search

<http://tv.somanuals.com>