

DUKANE

Intelligent Assembly Solutions

iQ Series

ULTRASONIC GENERATOR/POWER SUPPLY

LS

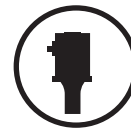

AUTOMATED



HAND PROBE



PRESS

User's Manual



Dukane Part No. 403-574-01

Dukane Intelligent Assembly Solutions • 2900 Dukane Drive • St. Charles, Illinois 60174 USA • TEL (630) 797-4900 • FAX (630) 797-4949

ISO 9001:2008 Products are manufactured in ISO registered facilities.



www.dukane.com/us

Download from Www.Somanuals.com. All Manuals Search And Download.

Copyright © 2010

Notice of Rights:

All rights reserved. No part of this manual including the interior design, cover design and icons may be reproduced, transmitted or utilized in any form or by any means, electronic, mechanical, photocopying, recording, or by any information storage and retrieval system, without written permission from the manufacturer.

Notice of Liability:

The information contained in this manual is distributed on an "As is" basis, without warranty. While every precaution has been taken in the preparation of this manual, the manufacturer shall not have any liability to any person or entity with respect to any liability, loss, or damage caused or alleged to be caused directly or indirectly by the instructions contained in this manual, or by the hardware products described herein.

Specifications are subject to change without notice.

This user's manual documents product features, hardware, and controls software available at the time this user's manual was published.

Printed in the United States of America.

Part Number: 403-574-01

This ultrasonic equipment is manufactured under one or more of the following U.S. Patents:

3,780,926 3,825,481 4,131,505 4,277,710 5,798,599 5,880,580 6,984,921 7,225,965 7,475,801, and 7,819,158 B2

Revision History

Revision Number	Revision Summary	Date
- 00	Original release.	01/25/2008
- 01	Add High Power models. Update system I/O pin descriptions. Add Trigger by Power. Add <i>iQ LinQ</i> TM . Web address revised. Revise Regulatory Agency Compliance statement. Health and Safety - Add safe lifting practices. Installation - Add lockout/tagout information and seismic zone information.	09/21/2010
	Page 25 - Edited to clarify need for external power supply.	11/24/2010

This page intentionally left blank

Contents

Section 1- Introduction	1
General User Information	
Read the Manual First	
Notes, Cautions and Warnings	
Drawings and Tables	
Generator Overview	
Key Generator Features	
Section 2 - Health and Safety	5
General Considerations	
Plastics Health Notice	
Electrical Safety	
Lifting the Equipment	
Section 3 - Installation	11
Before Installation	
Unpacking	
Placement	
RFI Grounding	
Connecting Cables	
Manually Operated Probe System	
Power Cords	
Automation Controlled Probe System	
Section 4 - Standard Connections	21
Rear Panel Layout Overview	
AC Power Inlet Panel	
System I/O Panel	
Section 5 - Standard System Status and Controls	35
Front Panel Overview	
System Displays	
Control Keys	
Start-up Sequence	
Stopping the Weld Cycle	
System Parameter Settings Overview	

Continued on next page

SECTION 1

Introduction

General User Information	3
Read the Manual First.	3
Notes, Cautions and Warnings	3
Drawings and Tables.	3
Generator Overview	4
Key Generator Features.	4

This page intentionally left blank

General User Information

Read the Manual First

Before operating your ultrasonic generator, read this User's Manual to become familiar with the equipment. This will ensure correct and safe operation. The manual is organized to allow you to learn how to safely operate this generator. The examples given are chosen for their simplicity to illustrate basic operation concepts.

Notes, Cautions and Warnings

Throughout this manual we use NOTES to provide information that is important for the successful application and understanding of the product. A NOTE block is shown to the right.

In addition, we use special notices to make you aware of safety considerations. These are the CAUTION and WARNING blocks as shown here. They have important information that, if ignored, could have increasingly severe outcomes. These statements help you to identify and avoid hazards and recognize the consequences. One of three different symbols also accompany the CAUTION and WARNING blocks to indicate whether the notice pertains to a condition or practice, an electrical safety issue or an operator protection issue.

Drawings and Tables

The figures and tables are identified by the section number followed by a sequence number. The sequence number begins with one in each section. The figures and tables are numbered separately. The figures use Arabic sequence numbers (e.g. 1, 2, 3) while the tables use roman sequence numerals (e.g. I, II, III). As an example, Figure 3-2 would be the second illustration in Section 3 while Table 3-II would be the second table in Section 3.

NOTE

Note statements provide additional information or highlight procedures.

CAUTION

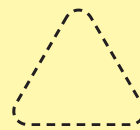

Caution statements identify conditions or practices that could result in damage to the equipment or other property.

WARNING



Warning statements point out conditions or practices that could result in personal injury or loss of life.



Condition
or Practice



Electrical
Hazard



Hearing
Protection

Generator Overview

This generator is designed for basic ultrasonic applications that use either manually operated hand probes or ultrasonic probes controlled by automation systems. Using the available system control inputs and output status signals, it can easily be controlled by automated machines.

The generator design accepts several control input signals, and provides system status output signals.

This product has rugged internal ultrasonic generator circuitry and ensures a continuous resonant frequency lock at the start of each weld.

Users may program the generator setup parameters to meet a wide variety of ultrasonic processing requirements.

The generator's compact size allows multiple units to be placed into an industrial equipment cabinet. This generator will operate at the same international line voltage input specifications as the other generators of this product family (unless the 120V option is installed). It also includes an RFI line filter that passes FCC and strict CE test specifications for global applications.

Key Generator Features

- **Program the Generator** with up to 16 setups.
- **Process Parameters** such as frequency, amplitude and power are all updated at a .5 ms rate.
- **Pulse Width Modulation** incorporates patented circuitry giving the power supply the ability to efficiently change the output amplitude. This makes it possible to start large horns with reduced power. It also provides more power-efficient switch-mode generator operation and increased reliability.
- **Linear Ramp Soft-Start** circuitry allows the acoustic stack to be brought to operating amplitude smoothly, minimizing start-up surges and abnormal stress to the stack and generator.
- **Automatic Tuning** tracks the resonant frequency of the acoustic stack (horn, booster, transducer) and adjusts the generator output frequency to match it. This is done for every weld cycle and eliminates the need to manually tune the generator.
- **Line Voltage Regulation** automatically maintains constant amplitude regardless of line voltage deviation. The available output power is maintained with any voltage input within the specified range. This provides consistent system performance regardless of line

voltage fluctuations. It also eliminates the need for bulky, external constant-voltage transformers.

- **Load Regulation** provides constant ultrasound amplitude automatically regardless of power draw. The ultrasonic output amplitude level is held to within $\pm 1\%$ to provide weld process consistency and reduced weld cycle times.
- **High Line Voltage Power Supply** means that standard systems will operate worldwide at the local high line voltage level, whether it is 200VAC @60Hz in Japan, 240VAC @50Hz in Europe or 208VAC @60Hz in the United States. There are no internal transformer taps to change for worldwide operation.
- **Low Line Voltage Power Supply** - This optional 120V power supply is designed for North American applications.
- **Flow Through Cooling Tunnel** with a matched high-performance heatsink and thermostatically controlled fan reduces thermal gradients and increases component life.
- **AC Power Inrush** protection reduces electrical stress on the internal components by protecting them from AC power startup transient current surges.
- **Multiple Electronic Overload** protection circuits prevent instantaneous component failure in the event of extreme output overload conditions. The overload power limit is based on the actual true RMS power output level.
- **Process Limits** include: time only, time and energy, and peak power. These programmable limits provide the means to adapt to a wide variety of welding applications.
- **Control Board Option Modules** - The user can select one of the following: Multi-Probe Control, Automation Thruster Control, or Remote Amplitude Control. An isolated I/O Conversion Module is also available as a DIN rail-mounted module.
- **CE Certification** means that the system meets the required European standards to be sold and used in Europe (high line voltage models only).
- **ISO 9001 Certification** means that this system has been manufactured to high quality standards and assures you of manufacturing excellence.

SECTION 2

Health and Safety

General Considerations	7
Plastics Health Notice.	7
Electrical Safety	8
Domestic Power Grounding	8
International Power Grounding	8
Lifting the Equipment	9

This page intentionally left blank

General Considerations

Please observe these health and safety recommendations for safe, efficient, and injury-free operation of your equipment. In this manual, the term *system* refers to a complete group of components associated with the welding of plastic or metal parts, also known as an ultrasonic assembly system. A typical system consists of a generator and/or ultrasonic process controller, start and stop switches, power controls, connecting cables, and the probe assembly which includes the transducer, booster, horn and replaceable horn tip.

Proper Installation - Operate system components only after they are properly installed and checked.

No Unauthorized Modifications - Do not modify your system in any way unless authorized to do so by the manufacturer. Unauthorized modifications may cause injury to the operator and/or equipment damage. In addition, unauthorized modifications will void the equipment warranty.

Keep the Cover On - Do not remove any equipment cover unless specifically directed to do so by the manufacturer. The generator produces hazardous electrical voltages which could cause injury.

Grounded Electrical Power - Operate this equipment only with a properly grounded electrical connection. (See Electrical Safety Grounding Instructions on the next page.)

Comply with Regulations - You may be required to add accessories to bring the system into compliance with applicable OSHA regulations for machine guarding and noise exposure.

Plastics Health Notice

Before using any ultrasonic welding system, be sure you are familiar with OSHA regulations from the U.S. Department of Labor about the particular type of plastic(s) you are using.

When plastic materials are being processed, they may emit fumes and/or gases that could be hazardous. Make sure you have adequate ventilation whenever these plastics are processed.

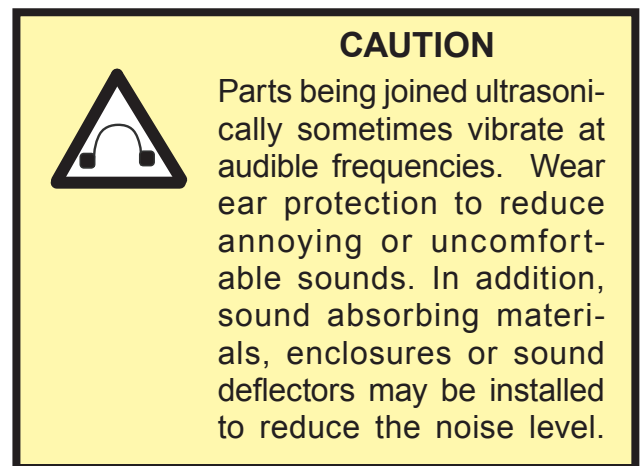

Electrical Safety

Domestic Power Grounding

For safety, the power cords used on this product have a three-wire, grounding-type power cord. Figure 2-1 illustrates the appropriate electrical outlet to use with the power cord that is included with systems shipped to North America.

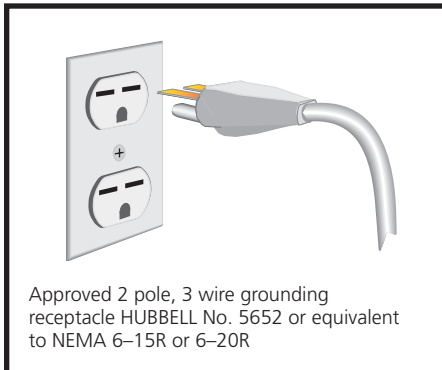

Figure 2-1 Example of 220/240 Volt, Grounded, 3-Prong Receptacle

International Power Grounding

The power cable normally provided for international use is compatible with the power outlet used in many Continental European countries (Refer to Figure 2-2.) However, if your application requires another type of power cord, check with your equipment supplier, and follow local regulations concerning proper wiring and grounding.

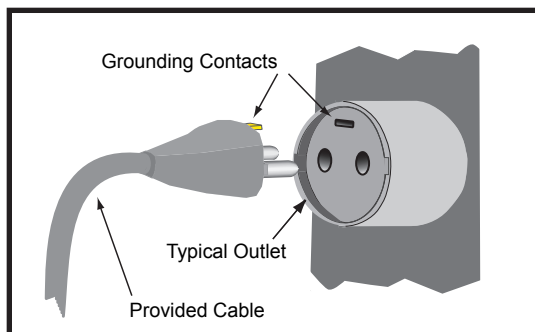

Figure 2-2 International 220/240V Grounding

CAUTION



If you have a two-prong electrical receptacle, we strongly recommend that you replace it with a properly grounded three-prong type. Have a qualified electrician replace it following the National Electric Code and any local codes and ordinances that apply.

See Figures 2-1 and 2-2.

CAUTION



If there is any question about the grounding of your receptacle, have it checked by a qualified electrician. Do not cut off the power cord grounding prong, or alter the plug in any way. If an extension cord is needed, use a three-wire cord that is in good condition. The cord should have an adequate power rating to do the job safely. It must be plugged into a grounded receptacle. Do not use a two-wire extension cord with this product.

NOTE

See *Section 10, Options* if your system has a non-detachable power cord for 120VAC operation.

Lifting the Equipment

	High Profile		Low Profile		High Power 3600W		High Power 4800 W	
	lb	kg	lb	kg	lb	kg	lb	kg
Generator Only	25	11.3	20	9.1	32	14.5	34	15.4
Generator + Packing Materials	30	13.6	25	11.3	37	16.7	39	17.7

Table 2-1 *iQ* Generator Weights

How to Lift Safely

- Before lifting, take a moment to think about what you're about to do.
- Examine the object for sharp corners, slippery spots or other potential hazards. Know your limit and don't try to exceed it.
- Ask for help if needed, or if possible, divide the load to make it lighter.
- Know where you are going to set the item down, and make sure it and your path are free of obstructions. Then follow these steps:
 - Step 1. Stand close to the load with your feet spread apart about shoulder width, with one foot slightly in front of the other for balance.
 - Step 2. Squat down bending at the knees (not your waist). Tuck your chin while keeping your back as vertical as possible.
 - Step 3. Get a firm grasp of the object before beginning the lift. Begin slowly lifting with your LEGS by straightening them. Never twist your body during this step.
 - Step 4. Once the lift is complete, keep the object as close to the body as possible. As the load's center of gravity moves away from the body, there is a dramatic increase in stress to the lumbar region of the back.
 - Step 5. If you must turn while carrying the load, turn using your feet-not your torso. To place the object below the level of your waist, follow the same procedures in reverse order. Remember, keep your back as vertical as possible and bend at the knees.

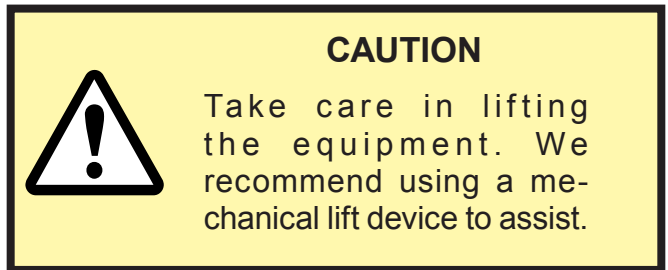

This page intentionally left blank

SECTION 3

Installation

Before Installation	13
When to Use Lockout/Tagout Devices	13
Unpacking	15
Placement	15
RFI Grounding	18
Connecting Cables	19
Manually Operated Probe System	19
Power Cords	19
Automation Controlled Probe System	20

This page intentionally left blank

Before Installation

As you plan for the installation of your generator, please consider these important subjects as listed below:

- When to use lockout / tagout devices
- Lifting the generator safely - See Section 2 - Health and Safety, P. 9

When to Use Lockout / Tagout Devices



Figure 3-1 Lockout Device In Open Position, Unlocked

The typical kind of LOTO device for this generator is a clam shell type device (with lockout capability). The LOTO device is placed over the plug end of the generator electrical cord. This effectively prevents access to the energy isolation point. See the example of one such device in the figure above.

The figure to the right shows the lockout device in the closed, locked position.

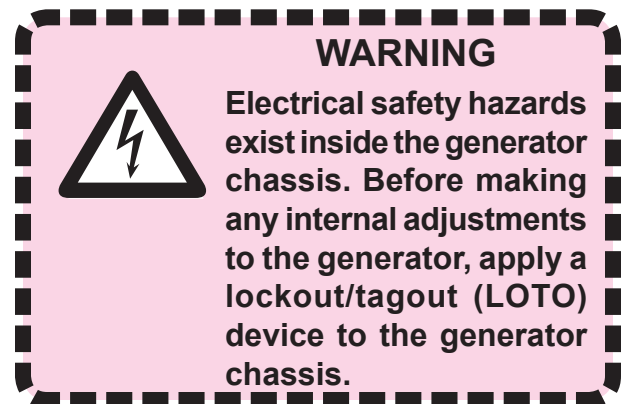

Figure 3-2 Bottom Lockout Device In Closed Position, Locked

Continued

Lockout/Tagout *Continued from previous page*

Procedure to use BEFORE making any internal adjustments to the generator:

1. Push the generator's AC power switch/breaker to the OFF position.
2. Unplug the generator's electrical cord from its source.
3. Authorized personnel apply a lockout/tagout (LOTO) device to the plug end of the generator's electrical cord. Using a typical clam shell type LOTO device:
 - 1) Open the clam shell.
 - 2) Place the electrical cord plug end inside the shell.
 - 3) Close the shell.
 - 4) Secure the shell with its lock, and lock it.
4. Wait a minimum of five minutes for the generator to discharge its electrical energy.
5. After taking these steps, make the necessary adjustments to the generator.

Assuming the generator is being put back into service. . .

Procedure to use AFTER making any internal adjustments to the generator:

1. Authorized personnel remove the lockout/tagout device from the plug end of the generator's electrical cord. Using a typical clam shell type LOTO device:
 - 1) Unlock the protective shell.
 - 2) Open the shell, exposing the electrical cord end.
 - 3) Remove the LOTO device, and set it aside.
2. Plug the generator's electrical cord into its AC power source.
3. Push the generator's AC power switch/breaker to the ON position.

Unpacking

Carefully open your shipping container, and make sure it contains the items shown on the shipping documents. Inspect all items, and report any damage immediately.

Placement

Generator placement and cable routing should permit easy access and not interfere with normal system operation.

Allow at least 5 inches (13 cm) of space on both ends of the generator chassis for air circulation. Allow a 3 inch space (8 cm) at the rear of the chassis for cable clearance.

See *Specifications, Section 11*, for detailed generator drawings.

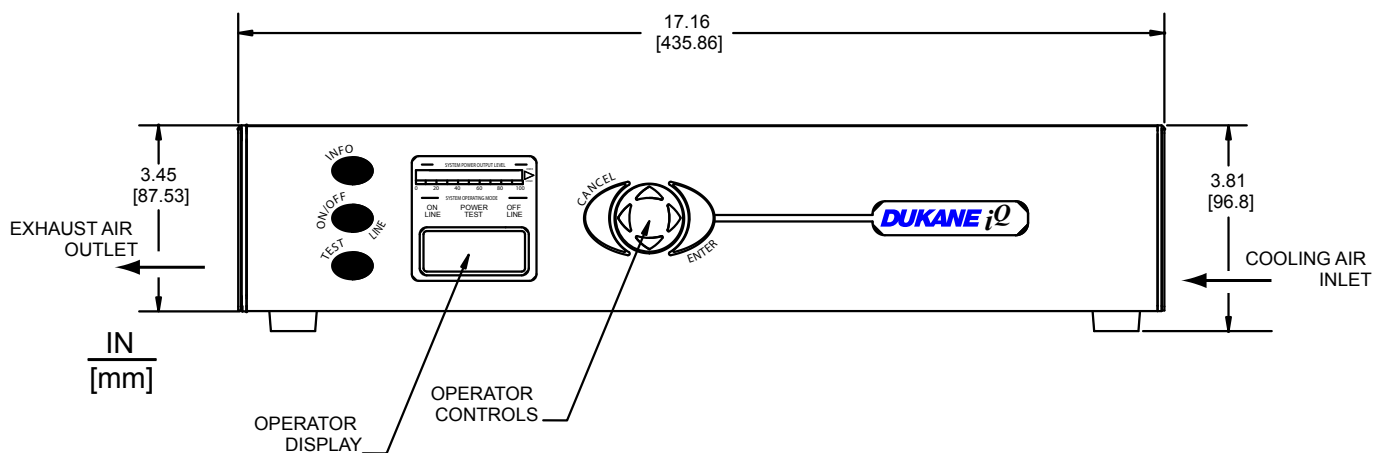
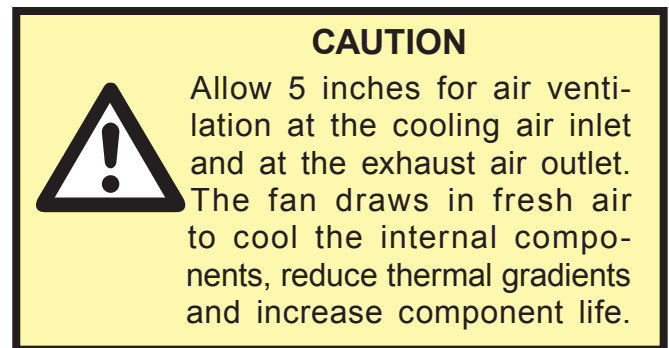

Figure 3-3 Generator - Front View (low profile model)

Placing the Generator when Used in an Active Seismic Region

If the *iQ* generator is to be used in an active seismic region, secure the unit by rack-mounting it or by securing the unit to a benchtop.

Rack-Mounting

Install the four brackets from Dukane's rack-mount kit to the generator. See Table 3-I, and Figure 3- 4 (showing a low profile unit) below.

Mount the generator to a 19-inch equipment rack.

System Type	Dukane Part Number
High Profile	147-4721
Low Profile	147-4720

Table 3-I Rack Mount Bracket Part Numbers

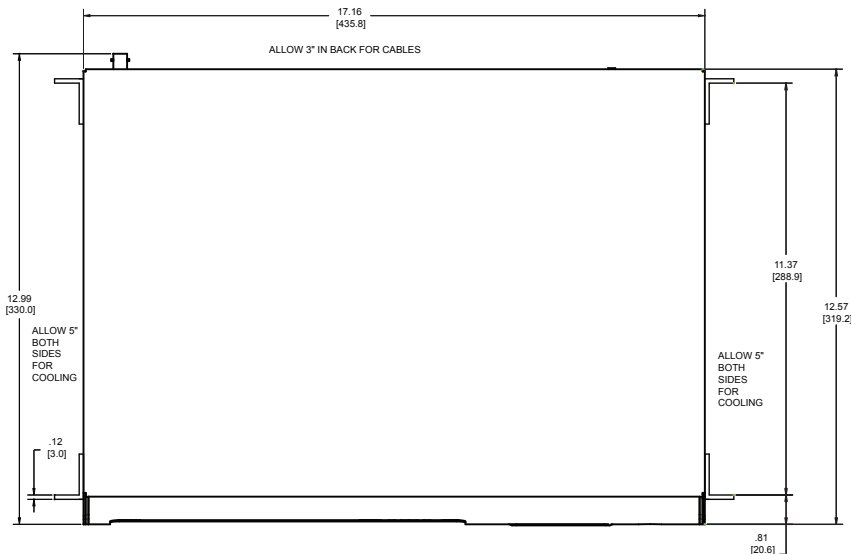

NOTE
The figure shows how a typical *iQ* generator is rack mounted. Your generator's appearance may be different from what is shown here.

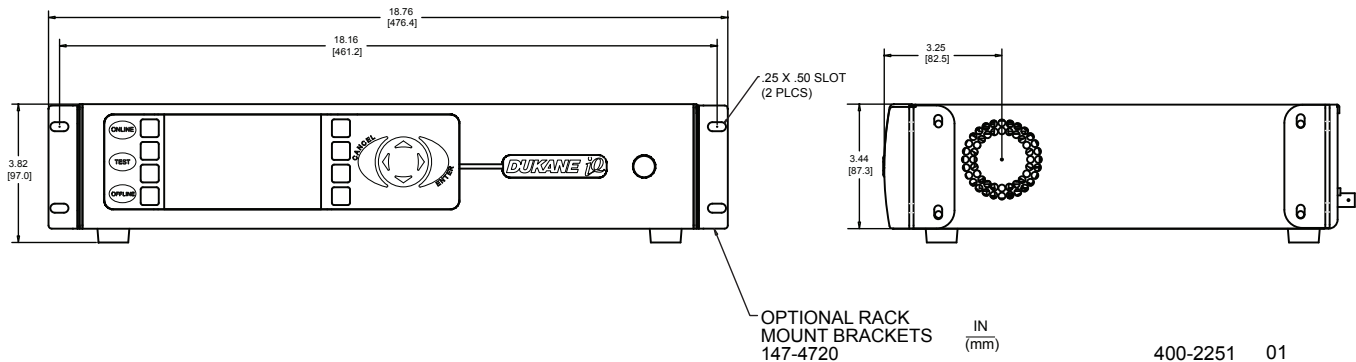

Figure 3-4 Rack Mounting *iQ* Generator

400-2251 01

Benchtop Mounting

If you choose to mount the generator on a benchtop follow these instructions:

- 1) Install the four (4) optional hold down brackets. See Figure 3-5 below.
- 2) Secure one side of each L bracket to the generator's sheet metal cover.
- 3) Secure the other side of each L bracket to the bench itself.

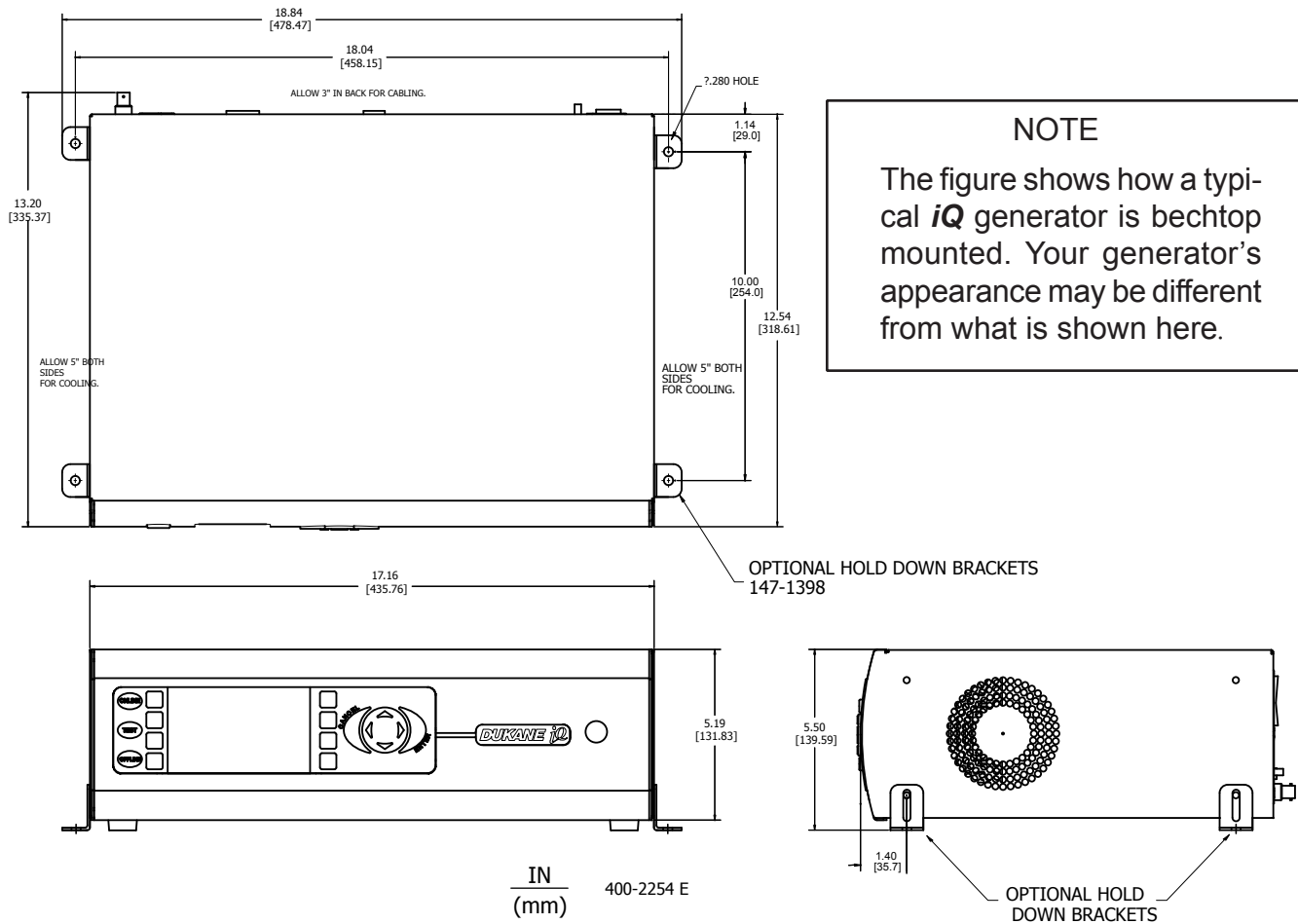
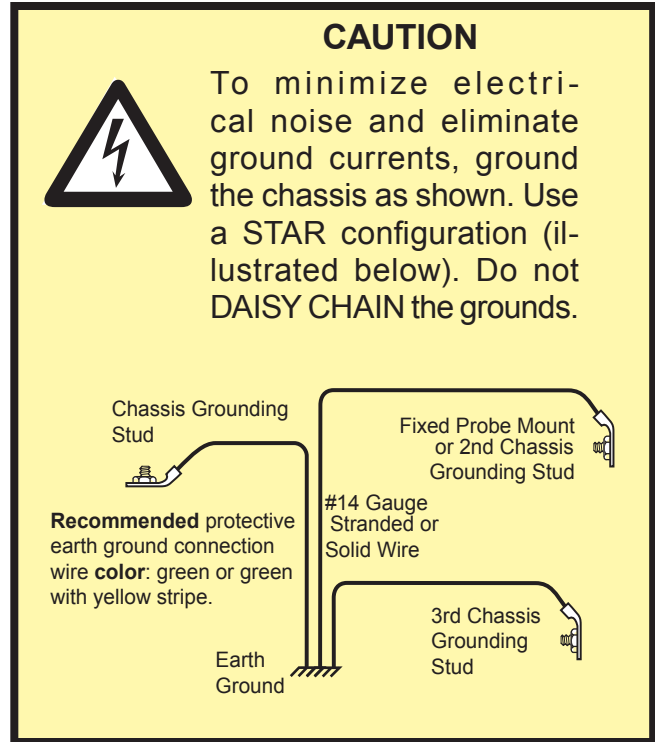

Figure 3-5 Securing *iQ* Generator to Benchtop

RFI Grounding

In addition to the safety considerations previously mentioned, proper grounding at the generator power cord is essential for the effective suppression of electrical noise or RFI (Radio Frequency Interference). Every ultrasonic generator contains a RFI filter which blocks noise on the AC power line from entering the system control circuitry. This filter also prevents ultrasonic frequency noise from being fed back into the AC power line. In order for the RFI filter to operate properly, it is necessary to correctly ground the system. Run a grounding wire from the grounding stud connection to the nearest grounded metal pipe or equivalent earth ground, and secure it with a ground clamp.

See Figure 3-6 on Page 20.



Connecting Cables (Quick Start Guide)

Details about the various system connectors and their pin assignments are covered in *Section 4*.

Manually Operated Probe System (Hand Probe)

- Step 1. Ground the generator chassis using the supplied 14-Gauge wire, and attach it to the grounding stud: **A** in Figure 3-6.
- Step 2. Attach the hand probe's HD-15 system input connector to J2 on the I/O panel: **B** in Figure 3-6.
- Step 3. Attach high-voltage coaxial cable to J1, the ultrasound output connector: **C** in Figure 3-6.
- Step 4. Connect the AC power cord to the IEC power inlet connector on the ultrasonic generator (**D** in Figure 3-6), and plug the other end into an approved AC outlet.

Power Cords

The AC line cords supplied with the standard generators are matched to the ultrasonic output power rating and the continent of specified use. See Table 3-II.

Continent of Use	Power Cord Part Number	Power
North America	200 - 1110	240V, 15A
	200 - 1541	240V, 10A
Continental Europe	200 - 1111	240V, 16A
	200 - 1542	240V, 10A

Table 3-II Standard IEC AC Power Cord Part Numbers



CAUTION

The power cord is equipped with a three-prong, grounded-type plug for your safety. Whenever a two-slot receptacle is encountered, we strongly recommend that it is replaced with a properly grounded three-lead receptacle.

Have a qualified electrician do the replacement in accordance with the National Electrical Code and local codes and ordinances. **DO NOT** cut off the power cord grounding prong or alter the plug in any way.

NOTE

Refer to *Section 10, Options* for information about optional features.

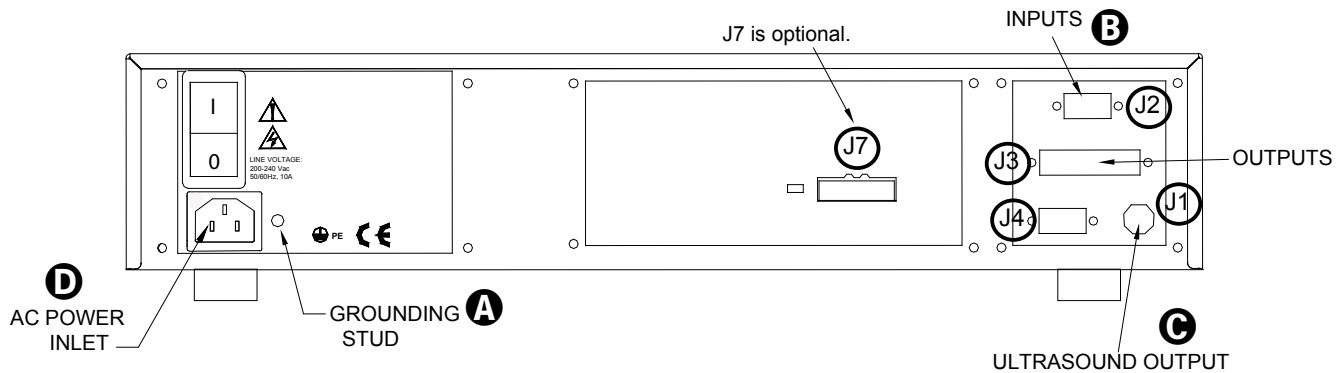

Figure 3-6 Generator - Rear View (low profile model)

Automation Controlled Probe System

- Step 1. Ground the generator chassis using the supplied 14-Gauge wire, and attach it to the grounding stud: **A** in Figure 3-6.
- Step 2. *Optional – Ground the probe support. This is a user-supplied 14-Gauge wire.*
- Step 3. Input Cable - Attach the automation control cable from the user-supplied automation equipment to the system input HD-15 connector, J2 on the I/O panel: **B** in Figure 3-6.
- Step 4. Output Cable - Attach an output cable - DB25 type - from J3 to your equipment to monitor system status.
- Step 5. Attach the high voltage coaxial cable from the probe to the ultrasound output connector J1: **C** in Figure 3-6.
- Step 6. Connect the AC power cord to the generator IEC power inlet connector, and plug the other end into an approved AC outlet: **D** in Figure 3-6.

NOTE

Refer to *Section 10, Options* for information about other features.

SECTION 4

Standard Connections

Rear Panel Layout Overview	23
AC Power Inlet Panel	24
IEC AC Power Inlet Connector	24
Power Switch/Circuit Breaker	24
Chassis Grounding Stud	24
System I/O Panel	24
System Inputs Connector	24
System Inputs Connector Pinout	25
System Inputs Signal Descriptions	26
System Outputs Connector	28
System Outputs Connector Pinout	28
System Outputs Signal Descriptions	28
Ultrasound Output Connector	32
Configuration Port Connector	33

This page intentionally left blank

Rear Panel Layout Overview

This section provides an overview of the generator rear panel layout, which includes panel areas dedicated to various standard system functions and options that are available. Figure 4-1 illustrates the panel layout.

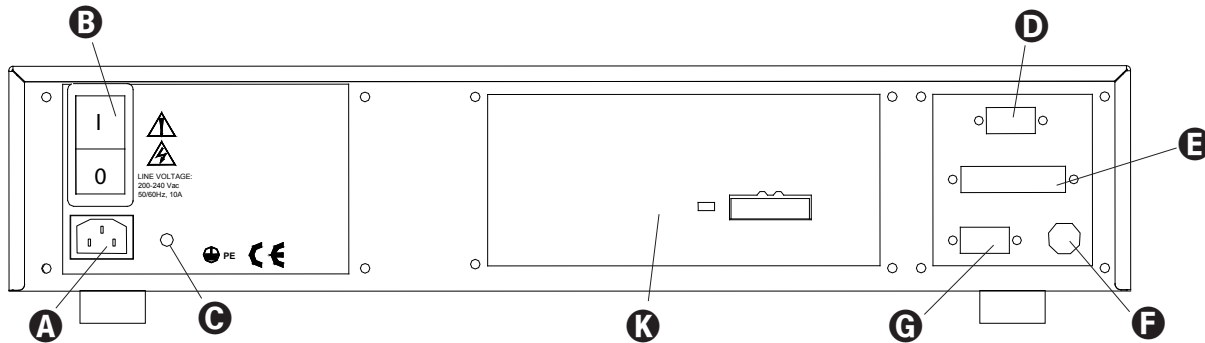

Figure 4-1 Generator Rear Panel

AC Power Inlet Panel

- A** IEC Power Inlet Connector – Attaches to an IEC style power cord.
- B** Power Switch – Circuit Breaker – Used to switch system power ON and OFF.
- C** Chassis Grounding Stud – Chassis connection for a protective earth ground.

The System I/O Panel

- D** System Input Connector – Connections for system control input signals.
- E** System Output Connector – Connections for system status output signals.
- F** Ultrasound Output Connector – Coaxial high voltage connection to ultrasonic stack.
- G** Configuration Port Connector – Digital control port to modify system parameters.

Options Module Panel

- (A blank panel is installed on standard systems.)
- K** An option module can be installed here.

NOTE

See Section 10, *Options* for more information.

AC Power Inlet Panel

The standard AC power inlet panel is described in this section.

IEC AC Power Inlet Connector

The IEC AC power inlet connector mounted on the system AC power inlet panel requires a properly configured IEC compliant power cord, which enables worldwide system operation by simply changing the power cord.

Low profile systems are equipped with a 10 amp rated IEC inlet connector. The high profile systems include a 16/20 amp rated IEC inlet connector. 120VAC and 3600W/4800W systems include a non-detachable power cord.

An appropriately rated power cord must be securely attached to the welding system's IEC inlet connector. If the correct power cord configuration is not included with the system for the local AC power outlet at your location, an appropriate IEC power cord should be available from a local electrical parts supplier. Note that the system under-voltage lockout will inhibit system operation if a North American power cord configured for 120V is connected to the system. A minimum of 200V is required for the system to operate.

Power Switch/Circuit Breaker

The power switch/circuit breaker has a rocker type actuator switch that will activate or deactivate the AC power to the system. The power ON position is marked with the internationally recognized **I** symbol, the power OFF position is marked with the **O** symbol. This power switch also integrates an appropriately sized over-current protection circuit breaker function in the generator.

If an over-current condition trips the circuit breaker, it will automatically switch to the OFF position. If the overload current that caused the circuit breaker to trip is due to a transient condition, the circuit breaker can be reset by switching the actuator back to the ON position. If when resetting the circuit breaker after it has tripped, it immediately trips again, there is likely an internal system malfunction, and the generator will require service.

Do not repeatedly try to reset the circuit breaker. If it trips, this will only cause more damage to the generator.

Chassis Grounding Stud

The chassis grounding stud is used to attach a protective earth ground to the generator. This will aid in the suppression of electrical interference or radio frequency interference (RFI) that is common in an industrial environment. The chassis ground stud is **Ⓞ** in Figure 4-2. Proper system grounding is discussed in *Section 3*.

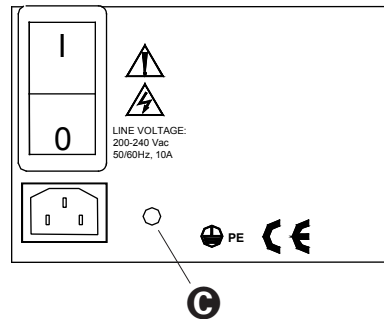

Figure 4-2 IEC AC Power Inlet Connector

System I/O Panel

The standard system I/O panel is described in this section.

System Inputs Connector

The SYSTEM INPUTS connector mounted on the system I/O panel includes connections for all of the basic system control input signals, that will typically come from an automated control system. The cable attached to this connector includes all of the available system control signals, which will be controlled by an output card or output port on the automation controller.

The user can determine which signals to use for each particular welding application, but there must be at least one connection to this connector in order to activate the ultrasound output. All of the input signals on this connector are electrically isolated (signals are NOT referenced to chassis ground) and activated when a 24VDC voltage source is connected to the signal input pin, referenced to the isolated common pin. The electrically isolated input signals can be driven from an automation controller output that is either sinking (NPN) or sourcing (PNP), depending upon how the isolated common connection is terminated. All inputs sink or source 10mA of current from a 24VDC power supply.

Note that a simple switch closure (relay contact) connected to a control input can not activate the input unless an external power supply is added to power the input.

However, if you don't want to add an additional power supply, you can configure switch closure inputs to operate referenced to chassis ground by adding jumper connections to the System Inputs connector.

For detailed wiring diagrams of example applications refer to *Application Note AN502* found on the Dukane website at:

<http://www.dukane.com/us/downloads.asp?type=Application%20Notes>

System Inputs Connector Pinout

The SYSTEM INPUTS connector is a HD-15F (high density D-subminiature 15 circuit female) connector. Connector pin assignments for this connector are shown in Figure 4-4. The male connector on the cable is a mirror image of the panel mounted connector and is shown in Figure 4-5. Table 4-I lists the signal names and descriptions, with more detailed descriptions that follow. The wire color coding for the system input cable is listed in Table 4-I, to assist with custom automation system wiring and assembly.

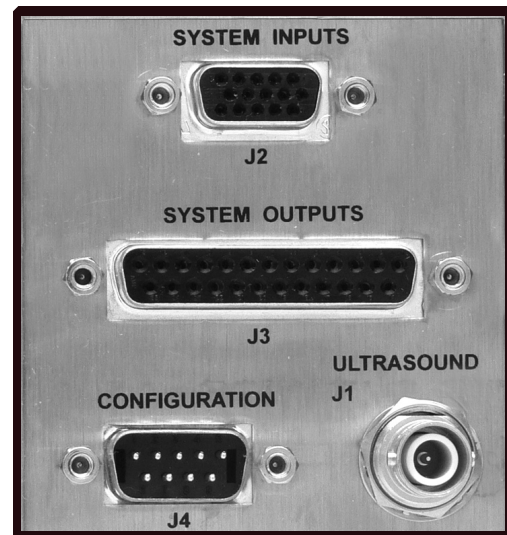

Figure 4-3 System I/O Panel (standard panel shown)

NOTE

Refer to *Section 10, Options* for information on optional features.

Pin	Signal Name	Cable Color Code	Signal Option Requirements
1	+22V	BLK	
2	Power Ground	WHT	
3	Remote Setup Selection Bit 0 Input	RED	MPC Option Required
4	Remote Setup Selection Bit 1 Input	GRN	MPC Option Required
5	Remote Setup Selection Bit 2 Input	ORN	MPC Option Required
6	Remote Setup Selection Bit 3 Input	BLU	MPC Option Required
7	Remote Setup Selection Bit 4 Input	WHT/BLK	Not Used
8	Ultrasound Activation/Cycle Start Input	RED/BLK	
9	Automation Thruster Control Input	GRN/BLK	Automation Thruster Board Required
10	Front Panel Control Lock Input	ORN/BLK	
11	Press Inhibit for Hand Probes	BLU/BLK	Hand Probe
12	System Latch Reset Input	BLK/WHT	
13	Isolated Common	RED/WHT	
14	Not Used	GRN/WHT	
15	Automation Cycle Stop Input	BLU/WHT	

Table 4-1 System Input Connector Signals (J2)

System Inputs Signal Descriptions

Pin 1 (+22V)

This pin can supply +22VDC at up to 250mA to power the user's automation controls.

Pin 2 (Power Gnd)

Pin 2 is the 22VDC return and is tied to the system chassis ground.

Pin 3 (Remote Setup Selection Bit 0 Input)

Pin 3 is the Remote Setup Selection Bit 0, which is the least significant bit used to select different welding setups with an automation control system. This input is also used to select different channels when a Multiple Probe Controller (MPC) Interface option board is installed.

Pin 4 (Remote Setup Selection Bit 1 Input)

Pin 4 is the Remote Setup Selection Bit 1, which is the second least significant bit used to select different welding setups with an automation control system. This input is also used to select different channels when a Multiple Probe Controller (MPC) Interface option board is installed.

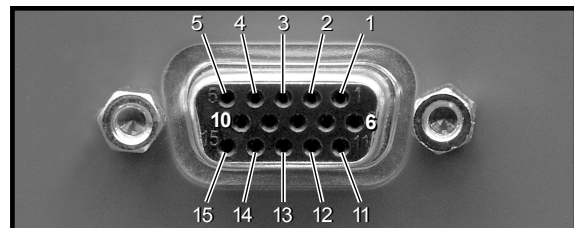

Figure 4-4 HD-15F, Generator Input Connector

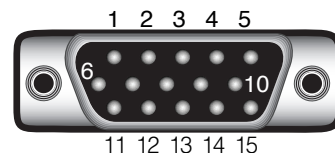

Figure 4-5 HD-15M, Generator Input Cable Connector

Pin 5 (Remote Setup Selection Bit 2 Input)

Pin 5 is the Remote Setup Selection Bit 2, which is the third least significant bit used to select different welding setups with an automation control system. This input is also used to select different channels when a Multiple Probe Controller (MPC) Interface option board is installed.

Pin 6 (Remote Setup Selection Bit 3 Input)

Pin 6 is the Remote Setup Selection Bit 3, which is the second most significant bit used to select different welding setups with an automation control system. This input is also used to select different channels when a Multiple Probe Controller (MPC) Interface option board is installed.

**Pin 7 (Remote Setup Selection Bit 4 Input)
(Not used on the basic model generator)**

Pin 7 is the Remote Setup Selection Bit 4, which is the most significant bit used to select different welding setups and can only be used with an advanced control system. This bit will not be used when a Multiple Probe Controller (MPC) Interface option board is installed.

Pin 8 (Ultrasound Activation/ Cycle Start Input)

Pin 8 is used to activate the generator ultrasound output. Activation of this control input will switch the ultrasound output ON, and deactivating this signal will switch ultrasound OFF. This input signal will also function as a cycle start input, where the ultrasound activation and timing are completely under the control of the process controller. Depending on the welding process controller setup, this input signal could be activated momentarily to start a welding cycle. *See Section 6 for more information.*

Pin 9 (Automation Thruster Control Input)

Pin 9 is used only when an optional automation thruster control board is installed. (*See Page 76.*) Activation of this input would cause the thruster attached to the option board to go to the down position. When this signal deactivates, the thruster will move to the up position. This option is typically used for a continuous welding process, when the user wants to retract the ultrasonic stack away from the process (or material) when the ultrasound is off or some changes in the process are being made.

Pin 10 (Front Panel Control Lock Input)

Pin 10 is used to lock the front panel user interface, so an operator cannot change any welding setups or configuration parameters that are stored in memory. The user can use the interface controls to view welding information, but no setup changes are allowed. Deactivation of this signal allows normal operation, without any lockout restrictions.

Pin 11 (Press Inhibit for Hand Probes)

Pin 11 is used to disconnect power applied to a press or thruster, if a hand probe is connected to the system input connector, for safety considerations. The hand probe activation switch could unexpectedly start a welding cycle that activates a press or thruster to the down position. The hand probe cable connector is wired to apply chassis ground to this pin, when it is attached to the system, which activates a press inhibit relay that disconnects power from the pneumatic press valves. This pin must be left open whenever a press control board is installed. Connecting this pin to chassis ground will inhibit press operation.

Pin 12 (System Latch Reset Input)

Pin 12 is used to reset the Any Fault or System Overload status outputs (See Status Output descriptions.). If a fault occurs during a weld cycle, these outputs will normally remain active until the next weld cycle is initiated. Activating this input will reset the status output faults and may simplify automation programming.

Pin 13 (Isolated Common)

Pin 13 is electrically isolated from chassis ground. Using isolated sourcing (PNP) output drivers, this common line would be connected to isolated ground potential. Using isolated sinking (NPN) output drivers, this common line would be connected to the isolated positive supply voltage output.

Pin 14 (Not Used)

Pin 14 is an open connection.

Pin 15 (Automation Cycle Stop Input)

Pin 15 is an input control signal that when enabled, can be used by the automation control system as a redundant signal to shut the ultrasound output off. This signal could also be reconfigured through menu selections to function as an automation end-of-weld control signal input.

System Outputs Connector

The SYSTEM OUTPUTS connector mounted on the generator I/O panel includes connections for all of the basic system status and monitor output signals, which will typically connect to an automated control system. The cable attached to this connector includes all of the available system output signals, which will be read or monitored by a digital input card or analog inputs on the user-supplied automation controller.

The user can determine which signals are appropriate for each welding application.

The system monitor output signals are analog signals used to monitor ultrasonic amplitude setting and ultrasonic output power levels, referenced to the Monitor Common (Pin 13). This is at system chassis ground potential (non-isolated). All of the digital output status signals on this connector, are isolated (signals are not referenced to generator chassis ground). When a status output signal is activated, it will sink current (500mA sourced by a 24VDC supply) to isolated common. In automation terms, the outputs are NPN (sinking) and would drive a PNP (sourcing) input that is referenced to the Isolated Common pin.

The digital status output signals can only sink current to isolated common. They cannot be changed to a sourcing (PNP) type output. If sourcing status outputs are required, there is an optional isolated NPN to PNP conversion module that is DIN rail mounted. The module converts the standard isolated sinking (NPN) status output signals to isolated sourcing (PNP) status output signals. Consult your local sales representative for information about the conversion module.

System Outputs Connector Pinout

The SYSTEM OUTPUTS connector is a DB-25F (standard D-subminiature 25 circuit female) connector. Connector pin assignments for this connector are shown in Figure 4-6. The male connector on the cable is a mirror image of the panel mounted connector and is shown in Figure 4-7. Table 4-II lists the signal names. Detailed descriptions are listed in the System Outputs Signal Descriptions section below. To assist with custom automation system wiring and assembly, the wire color coding for the system outputs cable is listed in Table 4-II.

System Outputs Signal Descriptions

Pin 1 (+22V Power Supply)

This pin can supply +22VDC at up to 250mA to power the user's automation controls.

Pin 2 (Not Used)

Pin 2 is an open connection.

Pin 3 (+22V Power Ground)

Pin 3 is the 22VDC return and is tied to the system chassis ground.

Pin 4 (Programmable Status Output 1)

Pin 4 is a digital active low status output that can be reprogrammed and assigned to another system status signal (from the available selections) using the front panel controller.

Pin 5 (Programmable Status Output 2)

Pin 5 is a digital active low status output that can be reprogrammed and assigned to another system status signal (from the available selections) using the front panel controller.

Pin 6 (Ultrasound Active Status Output)

Pin 6 is a digital active low status output that activates when the system is delivering ultrasonic power to the load attached to the ultrasound output connector. This output will be an open circuit when the ultrasound output is off.

Pin 7 (Any Fault Status Output)

Pin 7 is a digital active low status output that activates whenever any fault condition is detected that inhibits ultrasound output and normal system operation. This output will be an open circuit when no system fault conditions are detected. Any Fault output remains active until cleared by the System Latch Reset input or by the start of the next weld cycle.

Generator faults that will activate the Any Fault output:

- Overload (Average, Peak, Frequency)
- Over Temperature Fault
- System Power Fault
- Current Loop Fault

Pin 8 (Press Trigger Status Output)

NOT AVAILABLE.

Pin 9 (System Overload Status Output)

Pin 9 is a digital active low status output that activates whenever any overload condition is tripped. Activation of the overload status output signal could be caused by an Average, Peak or Frequency overload condition. After the overload status output activates, it will remain active until the next ultrasound activation cycle begins and this output will automatically reset. This output will be an open circuit when no overload conditions have been detected.

Pin 10 (System On-Line Status Output)

Pin 10 is a digital active low status output that activates when the system is in the ONLINE operating mode, which enables the activation of the ultrasonic output. This output will be an open circuit if the system is switched to the OFFLINE operating mode, or if an externally connected E-Stop has been activated, and the open circuit prevents the start of a welding cycle or activation of the ultrasound output. Note that an automation controlled process can not weld any parts, if the system is, accidentally or otherwise, switched to the OFFLINE operating mode.

Pin 11 (Press Top of Stroke Status Output)

NOT AVAILABLE.

Pin 12 (Current Loop OK Status Output)

This status output signal will activate only when a Remote

Amplitude Control Board is installed in the system. Pin 12 is a digital active low status output that activates when the current loop input to the remote control option board is connected and working normally. This output will be an open circuit when the current loop input signal is too low for proper system operation (less than 2mA). This may be due to a broken wire connection, a failed current loop controller or the current loop input wired incorrectly to the input terminal block.

Pin 13 (Analog Monitor Signal Common)

Pin 13 is the signal common (ground) connection for all of the analog monitor signals (on Pins 14, 15 and 16). This signal common pin is connected to system chassis ground and is not isolated from the generator chassis. This is an analog signal ground connection. Do not connect anything to this ground connection, except the wiring to the inputs of the analog instrumentation devices used to measure the monitor output signals.

Pin 14 (Not Used)

Pin 14 is connected to the system chassis ground.

Pin 15 (Power Signal Monitor Output)

Pin 15 is an analog output signal used to monitor the power output from the welding system. The scaling on this output signal is as shown below:

15kHz, 20kHz, 30kHz and 40kHz systems:

1 Watt = 0.001 VDC (1mV per Watt)

Example: • 20kHz system measures 0.525 VDC on

Power Monitor Output = 525 Watts.

Pin 16 (Amplitude Monitor Output)

Pin 16 is an analog output signal used to monitor the system amplitude setting. The scaling on this output signal is 100% amplitude = 10.0 VDC, or 0.1 VDC per 1% amplitude. This monitor signal output would typically be used when a remote control option board is installed in the system. The automation control system will adjust the system's amplitude setting remotely, using a 4-20mA current loop attached to the input of the remote control board. Using this monitor output, the control system can verify that the amplitude is set to the expected programmed amplitude level.

Pin 17 (Amplitude/Power Regulation Status Output) (Contact your sales representative about Power Regulation availability.)

This status signal is most useful when the power regulation mode is selected. This Out of Regulation status signal would indicate that due to inadequate pressure against the ultrasonic horn, the power regulation level setting can not be achieved when the amplitude level is set to the maximum level of 100%.

In the amplitude regulation mode, this signal will be activated at the end of the ramp-up time until the beginning of the ramp-down time. This status signal will be active for the time the ultrasound is at the programmed amplitude setting.

Pin 17 is a digital active low status output that activates when the system is regulating the amplitude or power level correctly. This output becomes an open circuit when the system falls out of regulation. When that happens, it cannot adjust the system output to the output level that was programmed as the regulation set point.

Pin 18 (MPC Ready Status Output)

This status output signal will activate only when an MPC interface board is installed in the generator. Pin 18 is a digital active low status output that activates when the MPC controller is ready to accept changes on the probe selection control bits and ready to start the next MPC welding cycle. This output will be an open circuit when the MPC system is not ready to accept changes to control input signals.

Any changes will be ignored until this status output signal activates to the ready state. This status output signal will also be open (MPC NOT READY) if a fault condition is detected inside the MPC system. If this status output will not activate, check for a red fault status indication, the SYSTEM STATUS LED, on the front of the MPC module.

Pin 19 (System Power OK Status Output)

Pin 19 is a digital active low status output that activates when no fault conditions are detected by any of the power fault detection circuits included in the system. This output will be an open circuit when any power related fault is detected in the system.

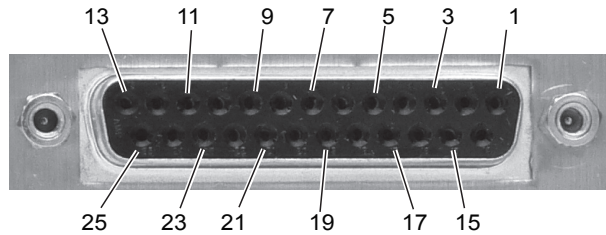

Figure 4-6 DB-25F, Generator Output Connector (J3)

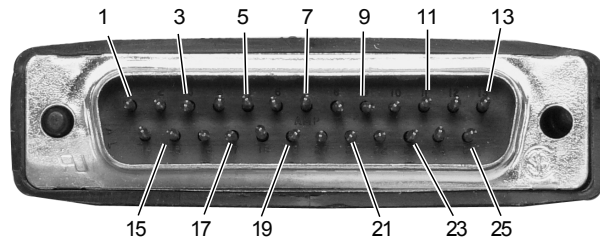

Figure 4-7 DB-25M, Generator Output Cable Connector

Pin 20 (Bad Part Status Output)

Pin 20 is a digital active low status output that activates, either momentarily or until the start of the next welding cycle, when the welding parameters recorded during the previous welding cycle are outside of the programmed bad part limits. This output will be an open circuit when a bad part has not been detected.

Pin 21 (Good Part Status Output)

Pin 21 is a digital active low status output that activates, either momentarily or until the start of the next welding cycle, when the welding parameters recorded during the previous welding cycle do not exceed the programmed suspect or bad part limits. This output will be an open circuit after a welding cycle when either a suspect or bad part has been detected.

Pin 22 (System Ready Status Output)

This status output signal will activate only when the system is ready to activate ultrasound or begin a weld cycle. Pin 22 is a digital active low status output that activates when a weld processing cycle is completed and the welding process control system is ready to start the next welding cycle. This output will be an open circuit when the welding process controller determines that the next welding cycle cannot be started. This includes system faults or offline active, but not a process fault like Overload.

Pin 23 (Suspect Part Status Output)

Pin 23 is a digital active low status output that activates, either momentarily or until the start of the next welding cycle, when the welding parameters recorded during the previous welding cycle are outside of the programmed suspect part limits. This output will be an open circuit after a welding cycle when a suspect part has not been detected.

Pin 24 (Isolated Common)

Pin 24 is electrically isolated from chassis ground. This common line should be connected to negative output at a user-provided isolated 24VDC power supply. The isolated NPN status output signals can drive PNP inputs.

Pin 25 (Not Used)

Pin 25 is an open connection.

Pin	Signal Name	Cable Color Code	Signal Option Requirements
1	+22V	BLK	
2	Spare Output	WHT	
3	+22V Power Ground	RED	
4	Programmable Status Output 1	GRN	
5	Programmable Status Output 2	ORN	
6	Ultrasound Active Status Output	BLU	
7	Any Fault Status Output	WHT/BLK	
8	Press Trigger Status Output	RED/BLK	Not Available
9	System Overload Status Output	GRN/BLK	
10	System Online Status Output	ORN/BLK	
11	Press Top of Stroke Status Output	BLU/BLK	Not Available
12	Current Loop OK Status Output	BLK/WHT	Remote Control Option Board
13	Analog Monitor Signal Common	RED/WHT	
14	Not Used	GRN/WHT	
15	Power Signal Monitor Output	BLU/WHT	
16	Amplitude Monitor Output	BLK/RED	
17	Amplitude/Power Regulation Status Output	WHT/RED	
18	MPC Ready Status Outputs	ORN/RED	MPC Option Board
19	System Power OK Status Output	BLU/RED	
20	Bad Part Status Output	RED/GRN	
21	Good Part Status Output	ORN/GRN	
22	System Ready Status Output	BLK/WHT/RED	
23	Suspect Part Status Output	WHT/BLK/RED	
24	Isolated Common	RED/BLK/WHT	
25	Not Used	GRN/BLK/WHT	

Table 4-II System Output Connector Signals (J3)

Ultrasound Output Connector

The ultrasound output connector used with all standard generators is a high voltage (5000V) coaxial style SHV-BNC connector. This connector provides superior shielding of electrical noise, compared to other types of connectors. The ultrasound output connector mates with fully shielded coaxial ultrasound cables that are secured with a simple and reliable quarter-turn bayonet style attachment mechanism.

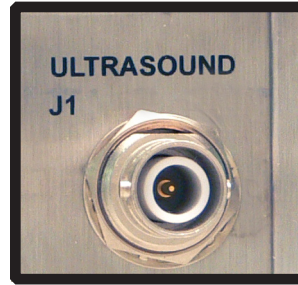

Figure 4-8 Ultrasound Output Connector

CAUTION



The ultrasonic output from this connector (that drives the attached ultrasonic load) is a very high AC voltage. At high power levels this can exceed 2 amperes of current and must be securely terminated via the ultrasound cable for safe operation. Use original equipment ultrasound cables for safe and reliable system operation. Improperly assembled ultrasound cables can result in high voltage arcing and will destroy the ultrasound connectors.

Do not use your generator if there is any evidence of arcing (black carbon deposits) on either the ultrasound output connector or the ultrasound cable connectors.

Configuration Port Connector

The configuration port connector is a DB-9M (standard D-subminiature nine circuit, male) typically used for RS-232 serial communications. This serial port (DTE) connects to a serial port (DCE) on a computer via a standard 9-pin serial cable. If the computer does not have a serial port, you may use a USB-to-serial conversion cable.

This port is used for field updates to the generator firmware, without removing the enclosure cover. This port can also be used with a software application running on a Windows PC to modify the factory default system settings and hardware configurations. Contact your local sales representative for software availability information and access to documentation that will allow you to make use of the configuration port features.

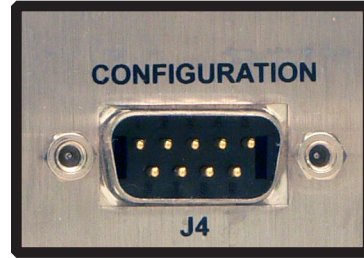

Figure 4-9 Configuration Port Connector

This page intentionally left blank

SECTION 5

Standard System Status and Controls

Front Panel Overview	37
System Displays	37
System Power Output Level (Bar Graph)	37
System Operating Mode	37
4-line LCD Display	37
Control Keys	38
INFO	38
ON/OFF Line	38
TEST	39
Arrow Keys	39
ENTER	39
CANCEL	39
Start-up Sequence	40
Stopping the Weld Cycle	41
System Parameter Settings Overview	42
Default System Parameter Settings	42

This page intentionally left blank

Front Panel Overview

This section provides an overview of the front panel's two main functions: monitoring (with the system displays), and controlling the system (with the user navigation control keys).

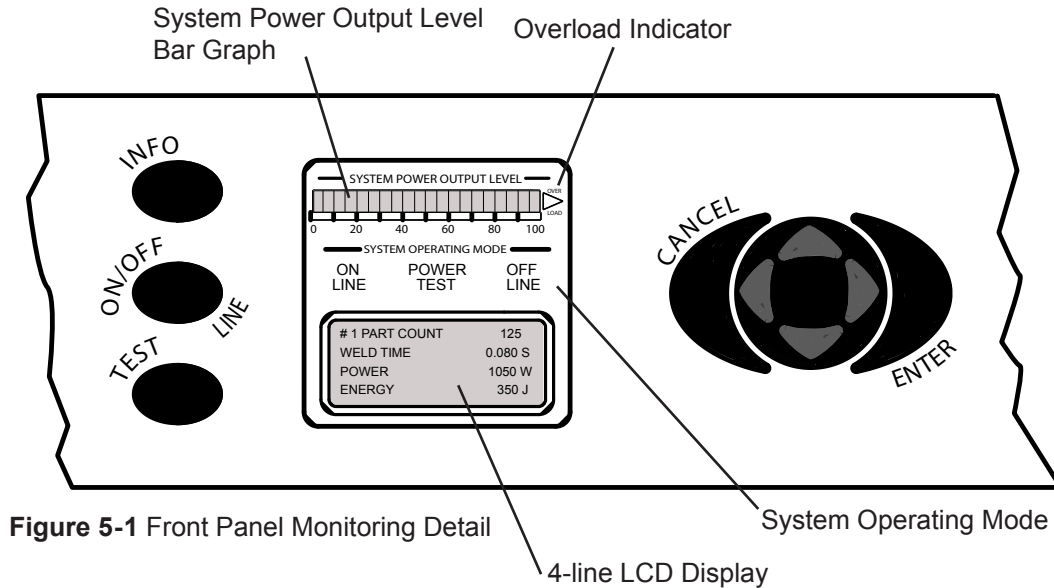

Figure 5-1 Front Panel Monitoring Detail

System Displays

System Power Output Level (Bar Graph)

A bar graph displays the percentage of ultrasonic power being drawn by the load.

The display uses LED's that show:

- GREEN - normal operation.
- YELLOW - warning of potential overload.
- RED - warning that an overload condition exists.

Peak Detect Feature

To indicate the maximum peak power achieved during a weld cycle, the LED in the bar graph corresponding to the peak level remains on (for about one second) after the weld cycle has been completed.

Flash on Overload at 90%

The OVERLOAD indicator begins to flash (RED) when the generator produces 90% of the overload power rating. This feature alerts the operator to an impending overload fault condition.

Bar Graph Power Scaling

Power scaling is related to amplitude. At 100% amplitude the whole graph is lit, and the generator is operating at 100% power. At 50% amplitude the entire graph is lit, and the generator is operating at 50% power.

If the amplitude setting is lowered, the graph rescales automatically according to the revised amplitude.

Example: With a 1200W generator, at 50% amplitude, if the whole graph is lit, that represents 600W.

System Operating Mode

ON LINE - ONLINE appears GREEN after AC power has been activated and the generator is operating normally.

POWER TEST - POWER TEST appears RED and will flash for several seconds when AC power is first turned on. The generator runs a self-test during the start-up sequence.

OFFLINE - OFFLINE appears YELLOW indicating that the generator's power output is disabled.

4-line LCD Display

This is where process control parameters can be set, and where process results can be monitored.

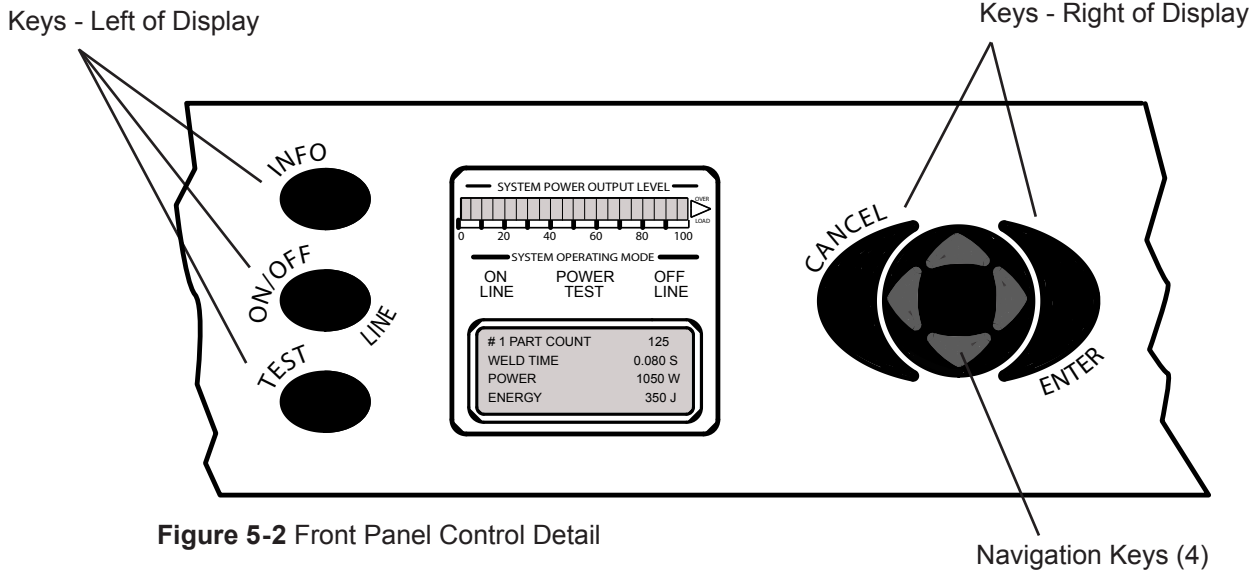



Figure 5-2 Front Panel Control Detail

Control Keys

Keys Left of the Display

INFO

After the primary weld method has been chosen, you can press the INFO key to go directly to the “Hot Key” screen where frequently used menus can be accessed. In the screens shown here, Energy is the weld method.

Use the up and down navigation keys, , to move the selection indicators, , to the desired selection. Press ENTER to proceed.

ON/OFF Line

The ON/OFF LINE key is used to deactivate the ultrasonic signal. For example, select OFFLINE during your process setup or to cycle the assembly equipment without ultrasound activated.

Weld Method - Time, Energy, Power,
- programmed by the user.
Time is the default method.

Screen shown in Setup Mode.

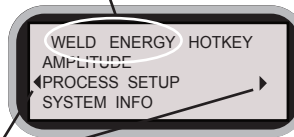

Screen shown in Operate Mode.

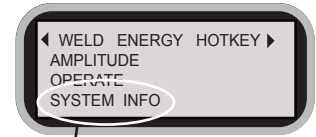

SYSTEM INFO will give the software version, model number.

CAUTION



If a transducer is not connected to the ultrasound output connector, the system should be set to the OFFLINE mode. Do not activate the ultrasound output without a transducer connected. Make sure that the stack is properly assembled before it is connected to the system. The horn should never come in direct contact with a metal fixture or anvil with ultrasound activated.

TEST

Hold the TEST key momentarily to activate ultrasound and view system operating parameters.

The LCD screen will show the real time settings for Amplitude, Power (does not appear with Time Only generators), and Operating Frequency.

This information is useful in troubleshooting.

While pushing the TEST key, look at the System Power Output Level meter (See the illustration to the right.) There should be at least one green LED segment lit.

IMPORTANT - If more than three LED segments are lit, with no load applied to the ultrasonic stack, make sure the stack is properly assembled and not damaged. During normal operation, the peak level LED remains lit (approximately 1 second) until the next cycle begins.

Control Keys Right of the Display

Navigation Keys

Press the **left and right navigation** keys to move the display’s cursor left or right respectively. Also, use these keys to move up one level in the menu, or to move back one level.

Press the **up and down arrow** keys to change the value of a selected digit.

ENTER

Press the ENTER key to select a menu item (shown by the selection indicators), and move to the next level of the menu. Think of it as a “forward” key.

Press ENTER to confirm and store a selection in memory.

CANCEL

Press the CANCEL key to return to the previous screen or cursor position. Think of it as a “back” key. Selection is not stored in memory.

NOTE
To activate the TEST mode, the system must be ONLINE.

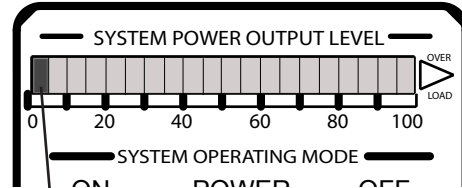
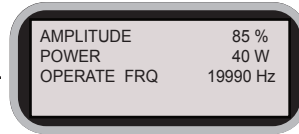

In this illustration, one LED segment is shown as lit after TEST was pushed.

CAUTION
If the System Output Power Level red overload indicator is lit, that means there is an overload fault. If this happens, verify that the ultrasonic stack is not damaged.

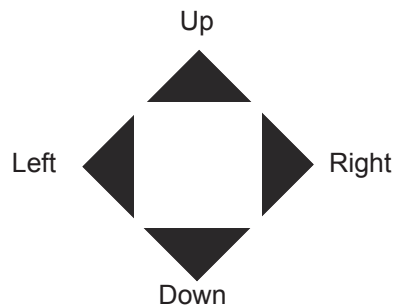

Navigation Keys (4)

Start-up Sequence

After all connections have been completed,

1. Push the rear panel AC breaker switch to ON.
The generator begins its self-diagnostics sequence.



2. POWER TEST flashes (RED) for several seconds.
3. First, the entire System Power Output Level bargraph lights up momentarily (verifying that all bar graph LED segments are functional). Next, two short “beeps” are sounded as the OVERLOAD LED flashes.
4. The System Operating Mode shifts to either ONLINE or OFFLINE depending on what was previously selected. See System Operating Mode on Page 31.
5. The LCD display identifies the Dukane *iQ* Series type first. Then another screen provides system detail.
See the Start-up (1 and 2) Figures 5-3 and 5-4 to the right.

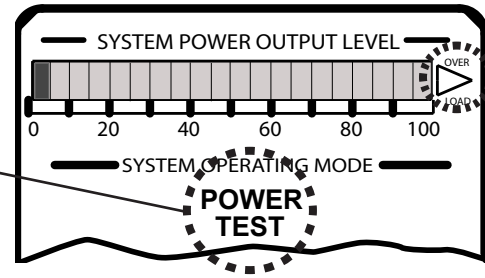

NOTE

A welding cycle cannot be started when the mode is OFFLINE because this blocks the ultrasound activation signal input.

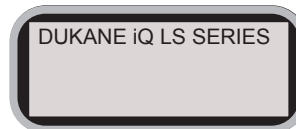

Figure 5-3 LCD Display at Start-up 1

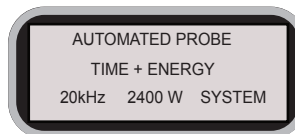

Figure 5-4 LCD Display at Start-up 2

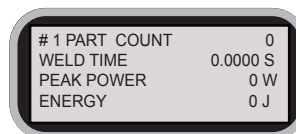

Figure 5-5 LCD Display at Start-up 3

6. When the diagnostics sequence is finished, the next screen to appear will look like Figure 5-5.

This is the Process Data screen, and that is linked to the OPERATE MODE menu.

This screen is updated after each weld cycle.

7. Press CANCEL twice and you will be at the Main Menu as shown at right.

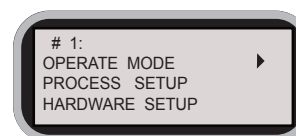

Figure 5-6 Main Menu

Stopping the Weld Cycle

Normal Conditions

The cycle stops when the programmed welding cycle ends.

Emergency Conditions

Manual System

Press OFFLINE to stop the ultrasound signal. This may be done under any condition.

Automated System

Customer-supplied external controls provide the means to stop the cycle for an automated system.

An auxiliary cable connects these external controls to the iQ generator at connector J2.

Control input labeled, “Automation Cycle Stop Input” (Pin 15) when activated will stop the weld cycle if configured as “End of Weld”.

System Parameter Settings Overview

This section provides the default system settings programmed at the factory. Some of these system parameter settings are dependent on the nominal system operating frequency while other parameters are independent of the frequency. The default settings should work with over 90% of the ultrasonic loads and welding applications that might be encountered. In some cases, adjusting the system setup parameters might enable the system to drive difficult or unusual loads, which would not be possible with the standard system settings.

In addition to the default system parameter settings, a list of user-adjustable settings is included.

NOTE

An ultrasonic stack will not operate if the mechanical resonance is outside of the frequency limits.

Default System Parameter Settings

Default Frequency Dependent Settings

Setting Description	15kHz	20kHz	30kHz	40kHz
Free Running Frequency Setting (Hz)	15,000	19,900	30,000	40,000
Upper Frequency Limit Setting (Hz)	15,400	20,400	30,500	40,500
Lower Frequency Limit Setting (Hz)	14,600	19,400	29,500	39,500
Ramp-up Time Setting (sec.)	0.250	0.150	0.100	0.050
Phase Delay Setting (degrees)	0°	0°	0°	0°

Table 5-I Default Frequency Dependent Settings

Default Frequency Independent Settings

Setting Description	Default Setting for All Frequencies
Amplitude Setting for Weld and Test (Percent)	100% (maximum user adjustment limit)
Output Activation Duration Process Status	Maintained (activates until next weld cycle starts)
Cycle Start Input Delay Time	Solid State (0.0msec. delay time)
Programmable Status Output #1 Default Assignment	OVERTEMP Status (J3 Pin 4 System Output)
Programmable Status Output #2 Default Assignment	Hold Status (J3 Pin 5 System Output)

Table 5-II Default Frequency Independent Settings

Continued

System Parameter Adjustment Limits*Continued from previous page*

Setting Description User Adjustment Limit	Setting Ranges for All Frequencies	
	Minimum	Maximum
Amplitude Setting	20%	100%
Free Run Frequency ***	Default Free Run Frequency minus 500 Hz	Default Free Run Frequency plus 500 Hz
Ramp-up Time	0.010 second	1.250 second
Phase Delay	Default Phase Delay minus 20°	Default Phase Delay plus 20°

Table 5-III System Parameter Adjustment Limits

*** NOTE: Free Run Frequency for 15kHz generators,
Minimum = Default Free Run Frequency minus 600 Hz;
Maximum = Default Free Run Frequency plus 600 Hz.

This page intentionally left blank

Section 6

Process Control Settings

User-Provided Process Control Overview	47
Manual Welding	47
Automated Welding	47
Automated Process Control Input Signals	47
Status Output Signals.	47
Screen Navigation Basics.	48
Programming the Generator - Some Examples	49

This page intentionally left blank

User-Provided Process Control Overview

The generator includes a process control system to control welding process. The basic “B models” can be programmed to weld by time. “E model” generators can weld by time and energy. See Figure 11-5 for model number information.

Manual Welding

Generally, a trained operator will start the welding process using a hand probe with an activation switch that starts the welding controller that controls the duration of the ultrasonic power applied to the parts being welded. The operator applies an appropriate amount of pressure to the parts to be ultrasonically joined. Then the operator activates the welding cycle, and the process controller begins the ultrasound output for a time (or energy) period that will reliably weld the final assembly. The quality of the finished product is particularly dependent on the skill of the hand probe operator.

Automated Welding

This automated welding control approach is custom designed by the user and can be very simple or quite sophisticated, depending upon the user’s requirements. In most cases, a Programmable Logic Control (PLC) system will be used to initiate the welding process. Then the front panel process controller controls the welding process. Output signals from the PLC system will determine when the ultrasound or weld cycle starts. Control signals for a Multiple Probe Control (MPC) system can also be easily added, if needed. A variety of ultrasonic welding status output signals are available to the automation system, which are useful in monitoring the welding process.

Automated Process Control Input Signals

Refer to *Section 4* for the available input control signals on the system input connector. The ultrasound/cycle start activation input will always be used, with the other available control input signals optional, depending upon the user’s processing requirements. The Front Panel Control Lock input and the System Latch Reset input are used with the front panel controller. The Auto Stop input provides an added means to shut off the ultrasound output and the Remote Setup Bit inputs allows the automation system to switch the system setups remotely.

Status Output Signals

Refer to *Section 4* for the available status output signals that are on the system output connector. Note that some of the listed status output signals are not functional if the system is not equipped with certain optional features. Using the available status output signals, the automation system can easily monitor when the ultrasound output is activated and other fault status signals, to assist in controlling the automated welding process.

Screen Navigation Basics

This section gives you a step-by-step guide to navigating through some of the basic menu structure.

1. Press CANCEL until you see the Main Menu screen as it is shown here. Selection indicator is on OPERATE MODE.



Selection Indicator

2. Press ENTER to view OPERATE MODE selections. Selection indicator is on PROCESS DATA.

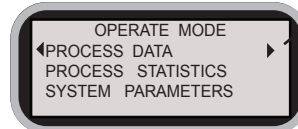

3. Press ENTER. The screen you see is the one that appears just after the generator is first switched ON.

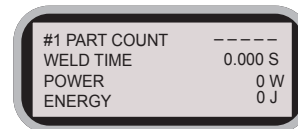

4. After viewing this screen, press CANCEL once to return to the OPERATE MODE menu.

5. Press the down arrow key, and select PROCESS STATISTICS.

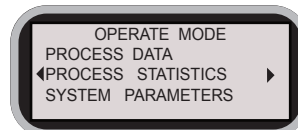

6. Press ENTER.

The next screen shows part statistics.

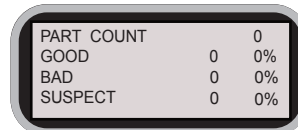

7. Press CANCEL to return to OPERATE MODE selections.

8. Using the up and down arrow keys, select SYSTEM PARAMETERS.

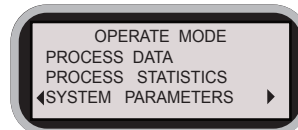

9. Press ENTER, and view the parameters.

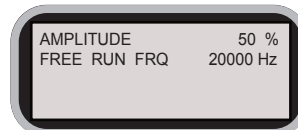

NOTE
POWER is added to the parameters display on "E model" generators as shown in the screen illustration below.

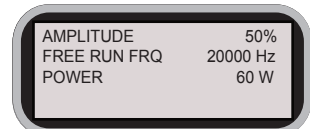

10. Press CANCEL to return to OPERATE MODE selections.

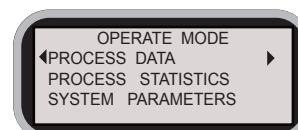

Programming the Generator - Some Examples

On the following pages these programming examples cover how to:

- **Have a PLC Control the Ultrasound Activation**
- **Weld by Time**
- **Weld by Energy**
- **Adjust Amplitude**
- **Adjust Ramp Up Time (Soft Start)**
- **Adjust Ramp Down Time (Soft Stop)**

NOTE

Once a primary weld method has been selected (Time, Energy, Peak Power), pressing the INFO key takes you to a “Hot Key” screen. There you can quickly move to the weld method’s frequently used programming areas.

HOW TO - Have a PLC Control the Ultrasound Activation

1. Press CANCEL until you see the Main Menu screen as it is shown here.

Move the selection indicator to PROCESS SETUP. _____

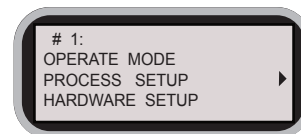

2. Press ENTER and you will see the screen as shown here. _____

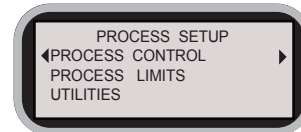

3. Select PROCESS CONTROL, and press ENTER.
With no option boards installed in the generator, you will get a WELD BY choice of iQ SYSTEM or AUTOMATION.

4. Select AUTOMATION. _____

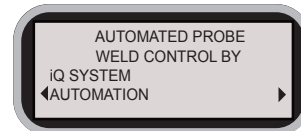

HOW TO - Weld by Time

1. Press CANCEL until you see the Main Menu screen as it is shown here.

Move the selection indicator to PROCESS SETUP.

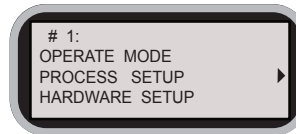

2. Press ENTER and you will see the screen as shown here.

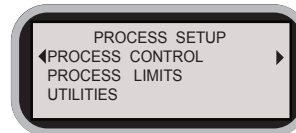

3. Select PROCESS CONTROL, and press ENTER.

With no option boards installed in the generator, you will get a "WELD BY" choice of iQ SYSTEM or AUTOMATION.

4. Select iQ SYSTEM, and press ENTER.

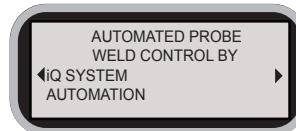

5. Select WELD CONTROL.



6. Select WELD BY TIME.

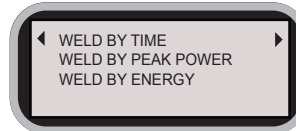

7. Select the digits with the RIGHT and LEFT arrows. Use the UP and DOWN arrows to select the value [time, in seconds] of each digit.



8. When done with the time entry, press ENTER, and an ENTRY ACCEPTED message will appear.

NOTE

In the above example we selected Time as the primary method of weld control. Next, the time of the weld was set (in seconds). The program will then ask the operator to choose and set a SECONDARY weld control. Choices the operator can make: Disable a secondary weld control, or enable either Peak Power, or Energy as the secondary weld control.

HOW TO - Weld by Energy (Available only if generator has energy option.)

1. Press **CANCEL** until you see the Main Menu screen as it is shown here. _____
Move the selection indicator to **PROCESS SETUP**.
2. Press **ENTER** and you will see the screen as shown here. _____
3. Select **PROCESS CONTROL**, and press **ENTER**.
With no option boards installed in the generator, you will get a **WELD BY** choice of **iQ SYSTEM** or **AUTOMATION**. _____
4. Select **iQ SYSTEM**, and press **ENTER**.
5. Select **WELD CONTROL**. _____
6. Select **WELD BY ENERGY**. _____
7. Select the digits with the **RIGHT** and **LEFT** arrows. Use the **UP** and **DOWN** arrows to select the value (energy, in Joules). _____
8. When done with the energy entry, press **ENTER**, and an **ENTRY ACCEPTED** message will appear.

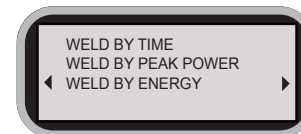
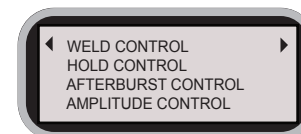
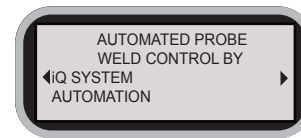
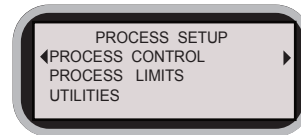
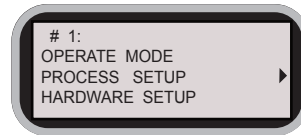

NOTE

In the above example Energy was the primary method of weld control. Next, the energy of the weld was set (in Joules). The program then asks the operator to choose and set a **MAX WELD TIME**, a secondary characteristic that also controls the weld. Select a time between 0 and 30 seconds. The time forces the weld portion of the cycle to stop even if the energy parameter is not met. Press **ENTER**. An **ENTRY ACCEPTED** message will appear.

HOW TO - Adjust Amplitude

1. Press CANCEL until you see the Main Menu screen as it is shown here.

Move the selection indicator to PROCESS SETUP.

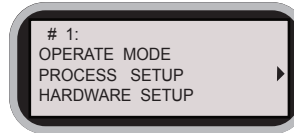

2. Press ENTER and you will see the screen as shown here.

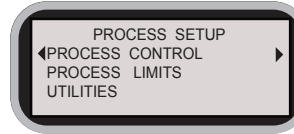

3. Select PROCESS CONTROL, and press ENTER.

With no option boards installed in the generator, you will get a WELD BY choice of iQ SYSTEM or AUTOMATION.

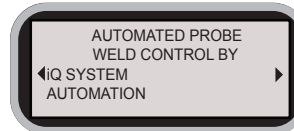

4. Select iQ SYSTEM, and press ENTER.

5. Select AMPLITUDE CONTROL.



6. Select AMPLITUDE SETTING.

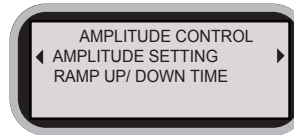

7. Adjust the amplitude. This is a value with a minimum of 20% and a maximum of 100%.

Select the digits with the RIGHT and LEFT arrows. Use the UP and DOWN arrows to select the value.

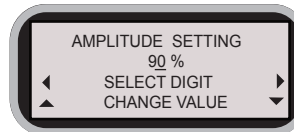

8. When done with the amplitude entry, press ENTER, and an ENTRY ACCEPTED message will appear.

NOTE

Once the amplitude is set and the entry is accepted, the program takes you back to the AMPLITUDE CONTROL screen. From there you may adjust the RAMP UP/DOWN times or go to some other part of the menu.

HOW TO - Adjust Ramp Up/Down Times

The **Ramp Up** feature, also called **soft start**, applies amplitude at the beginning of the weld cycle to start the stack assembly (transducer, booster, horn) *linearly*, rather than in two instantaneous surges. The stack is brought up to operating amplitude smoothly, without shock stress.

Although the Ramp Up time is factory set, it is variable and can be adjusted to account for starting characteristics of a particular horn.

The Ramp Up setting depends on the generator load at the start of a cycle.

Ramp Down, or **soft stop**, decreases amplitude as the weld cycle comes to an end. The stack is brought down from its maximum operating amplitude smoothly, reducing shock stress.

1. As in the previous HOW TO example, navigate to the AMPLITUDE CONTROL screen.

2. Select RAMP UP/DOWN TIME, and then press ENTER.

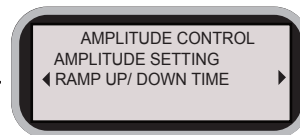

3. A WARNING will appear as shown to the right.
Call Dukane Service with any questions about making this adjustment.

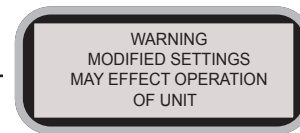

4. Select the feature (Ramp Up Time or Ramp Down Time) you want to adjust.

Adjust ramp up/down times. See the table below.

Select the digits with the RIGHT and LEFT arrows. Use the UP and DOWN arrows to select the value.

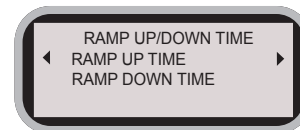

Feature	Seconds	
	Max	Min
Ramp Up	1.250	0.010
Ramp Down	0.250	0.000

Table 6-I Ramp Up/Down Times

When done with the entry, press ENTER, and the ENTRY ACCEPTED message will appear.

The program will take you back to the AMPLITUDE CONTROL screen.

This page intentionally left blank

SECTION 7

System Operational Testing

System Verification Tests	57
Preliminary Setup	57
Testing the Generator	57
System Test	58
Probe Operation	59
Stopping the Ultrasound Output	59
System with a User-supplied Emergency Stop Switch	59

This page intentionally left blank

System Verification Tests

Preliminary Setup

- Step 1. Plug in the AC line cord to the correct AC power outlet. See Table 11-II for the model power requirements.
- Step 2. Attach a compatible ultrasonic probe to the ultrasound output connector - J1.
- Step 3. Activate the AC Breaker/Switch **A** to the ON position.

Testing the Generator

(Complete steps 1-3 above, and then continue with steps 4, 5, and 6 below.)

- Step 4. The POWER TEST indicator **B** in the System Operating Mode display should flash red for several seconds, and then will go out.

Step 5. Mode Key Tests

- a. Set mode key **C** to OFFLINE.

The System Operating Mode OFFLINE indicator **D** will be yellow.

- b. Press the TEST **E** key (U/S INPUT).

The ultrasound should not activate, and the SYSTEM POWER OUTPUT LEVEL bar graph **F** will stay OFF (Gray).

- c. Set the MODE key to ONLINE.

The System Operating Mode ONLINE indicator **G** will be green.

- d. Press the TEST key **E**. Ultrasound should activate and the first segment of the SYSTEM POWER OUTPUT LEVEL bar graph turns green **H**.

Release the TEST switch.

Ultrasound should deactivate, and the SYSTEM POWER OUTPUT LEVEL bar graph should be OFF (gray).

- Step 6. Optionally, system status outputs can be monitored during this test.

The ultrasound status output activates only when ultrasound is active.

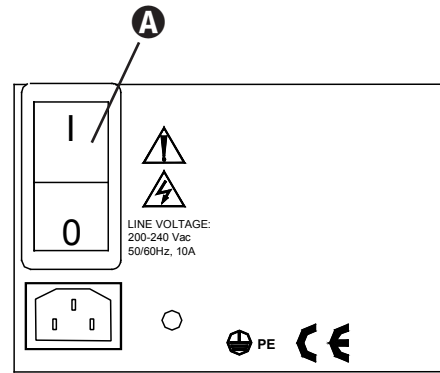

Figure 7-1 Rear Panel AC Breaker/Switch

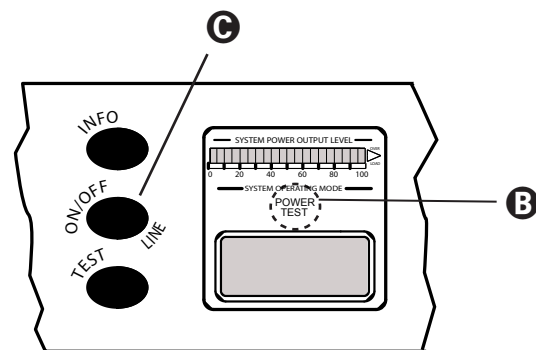

Figure 7-2 Front Panel POWER TEST LED

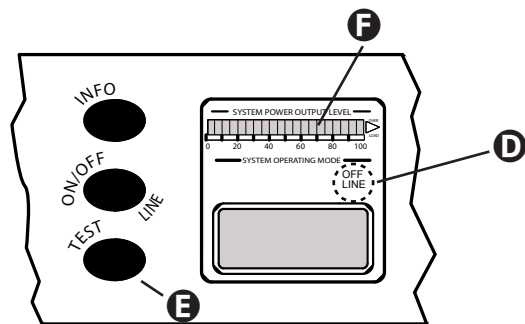

Figure 7-3 Front Panel OFFLINE LED

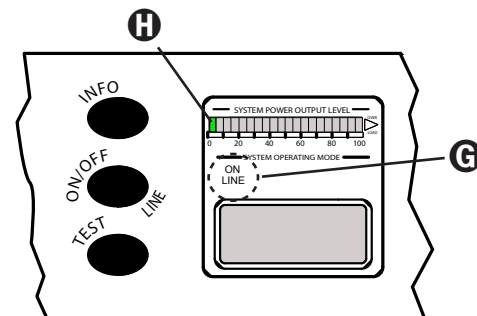

Figure 7-4 Front Panel ONLINE LED

System Test

To test the system's ultrasound operation, perform the following steps.

Step 1. For this test, the generator must be ONLINE. If the OFFLINE LED is showing yellow (D in Figure 7-3) press the ON/OFFLINE key.

The ONLINE LED (G in Figure 7-5) should turn green.

Step 2. Connect a probe to the generator ultrasonic output.

Step 3. Place the probe so that the tip of the horn is not in contact with anything. If you are using a hand probe, you may feel a slight vibration or sensation in your hand. This is normal. There should not be any loud or unusual noise.

Step 4. Momentarily press the TEST control key (E in Figure 7-5).

Step 5. The first segment LED of the SYSTEM POWER OUTPUT LEVEL bar graph (H in Figure 7-5) turns green. The probe will operate as long as the TEST key is pressed.

Step 6. When the TEST key is released, the SYSTEM POWER OUTPUT LEVEL bar graph turns off (gray). This test cannot be performed with the generator OFFLINE.

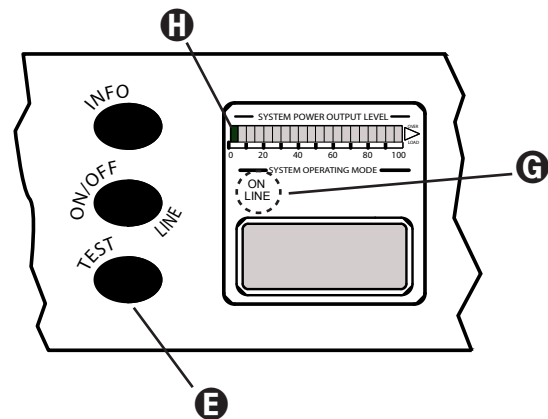
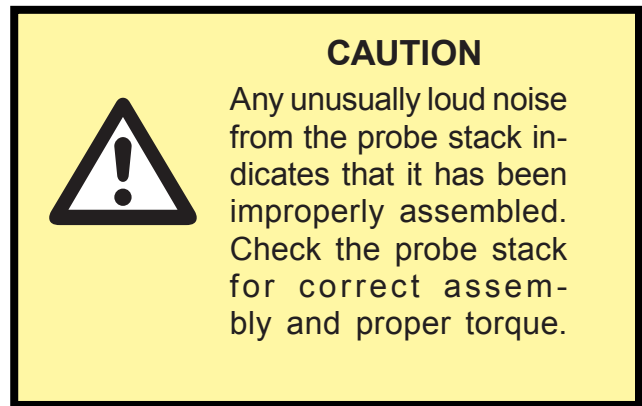

Figure 7-5 System Test

Probe Operation

1. If the generator is not online, press the ON/OFFLINE mode key, labeled **C** in Figure 7-6. The System Operating Mode ONLINE indicator (**C** in Figure 7-5) will be green.
2. Hand Probe – Apply the probe tip to the components to be ultrasonically joined, and press the hand probe's activation switch.
Automation System – Activate the automation system program to trigger the generator. This will move the probe tip in contact with the components to be ultrasonically joined, and run a welding cycle.
3. Hand Probe – The programmed welding time or energy will be processed, and then the ultrasound will be shut off.
Automation System – The programmed weld time will be processed, and then the ultrasound will shut off.

Stopping the Ultrasound Output

Set mode key **C** to OFFLINE. Ultrasound will deactivate.

System with a User-supplied Emergency Stop Switch

Press the emergency (E-Stop) switch, and the ultrasound signal will deactivate. - *This applies only if Auto Stop is wired to end user E-Stop circuits, AND Auto Stop is enabled.*

NOTE

Neither a hand probe or an automation system can trigger the generator to produce an ultrasound output if the generator is OFFLINE.

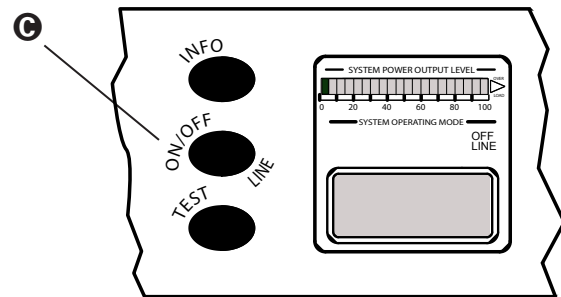

Figure 7-6 Stop Ultrasound Output

This page intentionally left blank

SECTION 8

Troubleshooting

No Ultrasonic Output	63
Probe	63
Cables	63
Generator	63
Operate Input	63
System Power Output Level: Red	64
Red - Fault Condition	64
Overload	64
Over Temperature	64
Generator Fault Does Not Reset.	64
System Power Diagnostic Procedures	64
AC Line Fault	64
DC Bus Fault.	64
Control Power Supply Fault	64
Welding Problems	65
Weak Welds	65
Excess Flash.	65
Inconsistent Welds	65
Pop-up Status Screens.	66

This page intentionally left blank

No Ultrasonic Output

Probe

Make sure that the probe coaxial cable is connected to the generator ultrasonic output connector J1. Basic generator models have the BNC connector on the rear panel. Also, make sure the probe stack was properly assembled.

Cables

Make sure that both the U/S coaxial and system I/O cables are securely connected. You must activate the ultrasound activation input to Pin 8 on the system input HD-15 connector either by the hand probe's control cable or with a custom automation input signal. Refer to Table 4-I, Generator Input Signals, for details.

Place the generator OFFLINE, and:

1. Check the coaxial cable for any signs of damage which may result in an open circuit preventing the cable from transmitting the signal from the generator to the probe.
2. If you have a mounted probe, replace the coaxial cable with a known good cable.
3. If you are using a hand probe, try a different known good probe to determine if the problem is related to the generator or the external cables and probe.

Generator

The generator will not produce an output signal when triggered if it is offline. (If the generator is OFFLINE, the system mode indicator shows OFFLINE in yellow.) To change the system to ONLINE, press the ON/OFFLINE mode key. When ONLINE, the system mode indicator shows ONLINE in green. Verify that at least one segment on the LED bar graph lights when the ultrasonic activation input signal starts a welding cycle.

Operate Input

If you are using a hand probe, make sure the control cable and adapter cable are securely connected to the system I/O connector. The trigger switch on the hand probe activates the ultrasonic output through the control cable.

NOTE

The cable end of the system I/O connector is a mirror image of the panel connector. Figure 8-1 below shows the cable pinout. Make sure you have correctly wired the connector if you are using custom automation signals.

Also refer to Table 4-II for the cable color pin assignment.

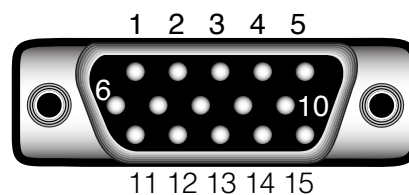

Figure 8-1 Cable End of System I/O Connector

System Power Output Level: Red

Red - Fault Condition

When the SYSTEM POWER OUTPUT LEVEL turns red (arrow on the right end of the bar graph), there is an overload condition that disables generator operation. See **J** in Figure 8-2 below.

Overload

When an overload occurs, it will automatically reset when the next ultrasound activation signal begins. If the condition persists:

Place the generator OFFLINE and:

1. Check the system: including cables, the acoustic stack, mounted probe, and/or hand probe. Replace existing components with ones you know are reliable.
2. Place the generator ONLINE, and see if the fault condition has been corrected.

Over Temperature

When the system overheats, there is an over temperature condition that will cause the fault, SYSTEM OVERTEMP DETECTED. (Fault status is indicated on the LCD screen. See Table 8-I.)

When the system cools, the system automatically resets.

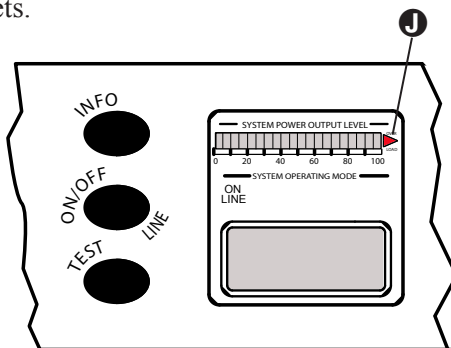

Figure 8-2 Overload Indication

NOTE

The LCD screen displays a variety of pop-up status changes as they occur. Check Table 8-I, Pop-up Status Screens, Page 58.

Generator Fault Does Not Reset

When the system does not automatically reset, the generator needs servicing.

System Power Diagnostic Procedures

AC Line Fault

If Power Status indicator (**B** in Figure 8-3 below) flashes RED at a fast rate of about four flashes per second:

- Check AC line voltage level – either an over/under voltage is sensed.
- Do not call service. Measure the voltage level at the AC outlet which is probably the source of the problem.

(Call service only if the AC line voltage is within the specified limits.)

DC Bus Fault

If Power Status indicator flashes RED at a slow rate of about one flash per second:

- This is normal for 10 to 15 seconds after power is switched ON.
- If flashing does not stop – a DC bus fault is sensed – call service.

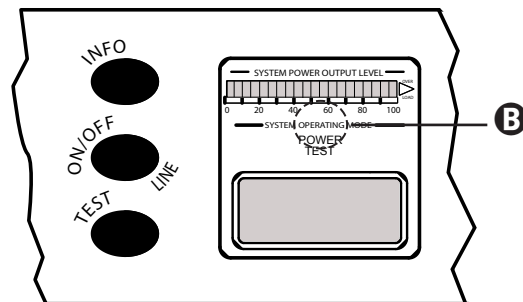

Figure 8-3 Power Status Indicator

Control Power Supply Fault

Power Status indicator doesn't flash, but is ON continuously RED:

- A control power supply fault is sensed – call service.

Welding Problems

Weak Welds

Weak welds, or underwelding, is caused by insufficient energy being transmitted to the part. You can increase the weld pressure, increase the weld time or change to a higher gain booster to increase the amplitude to increase the energy delivered to the weld.

Excess Flash

The energy director may be too large. You can try to reduce the weld pressure and/or weld time. The parts may have too much shear interferences or a nonuniform joint dimension.

Inconsistent Welds

Variations in plastic due to filler materials and moisture absorption may lead to inconsistent welds. Fillers can be especially troublesome if they are not uniformly distributed, the content is too high or it contains too much or poor quality regrind or degraded plastic.

Check the horn and fixture alignment and parallelism. Check the alignment of the mating parts, shifting during welding or residual mold release on the parts.

Try welding by energy. This eliminates many inconsistencies. There should be no unusual or loud noise from the acoustic stack. If there is, disassemble the stack and reassemble.

Exchange the probe with another unit to see if the problem disappears. If not, exchange the generator with another unit to try and isolate the problem.

The horn amplitude may not be uniform if it has been machined, altered or damaged. All of these will change the resonant frequency of the horn. You can have the horn analyzed.

Pop-up Status Screens

System Status Signal	Status Text Displayed	System Status or Fault Explanation
Average Overload	OVERLOAD - AVERAGE AT X.XXX SECONDS POWER ABOVE GENERATOR RATING	An Average Overload fault tripped. Output power exceeded rated wattage. Lower the welding pressure or amplitude. Fault will reset when next weld cycle starts.
Peak Overload	OVERLOAD - PEAK AT X.XXX SECONDS CHECK STACK OR COUPLING TO PART	A Peak Overload fault tripped. Peak IGBT transistor current exceeded. Caused by a severe frequency mis-match. Fault will reset when next weld cycle starts.
End of Weld	END OF WELD SIGNAL DETECTED	Automation activated End of Weld input. This ends the weld, then hold time begins. Status message is displayed a few seconds.
End of Cycle	END OF CYCLE SIGNAL DETECTED	Automation activated the End of Cycle input. This terminates the remaining weld cycle. Status message is displayed a few seconds.
Over Temperature Fault	SYSTEM OVER TEMP DETECTED	System Over Temperature fault detected. Check that cooling fan is operational. Check for dust build-up in cooling channel. Generator operation can continue after the system cools down.
Overload Frequency	OVERLOAD - FREQUENCY AT X.XXX SECONDS CHECK STACK AND CABLE & RAMP UP TIME	Resonant frequency was not found. Check for a defective stack component or for improper stack assembly. Check for a defective stack cable. Fault will reset when next weld cycle starts.
Overload Frequency	OVERLOAD - FREQUENCY AT X.XXX SECONDS CHECK FOR COUPLING BETWEEN STACK AND PART	Resonant frequency was lost during the cycle. Check for a defective stack component or for improper stack assembly. Check for stack coupling to the fixture. Fault will reset when next weld cycle starts.
4-20 mA Current Loop Fault	CURRENT LOOP FAULT DETECTED	Remote control current loop fault detected. Current loop current is less than 2mA. Check current loop wiring and loop source. This fault will set minimum amplitude level.
System Power Fault	SYSTEM POWER FAULT DETECTED	System AC line or power supply fault detected. Check that AC line voltage level is normal. Likely there will be no power for the front panel display. Service may be required if this fault is displayed.
Front Panel Locked	FRONT PANEL LOCKED KEYPAD ENTRY NOT ALLOWED	Front panel lockout input is activated. Front panel changes are not allowed. Warning pops-up if user attempts changes. Status message is displayed a few seconds.
Empty Setup	CURRENT SETUP HAS NOT BEEN PROGRAMMED WELD CYCLE STOPPED	Warning text pops-up if a setup is empty. User must program a valid welding setup.

Table 8-1 Pop-Up Status Screens

SECTION 9

Maintenance

Front and Rear Panels	69
Cleaning	69
Display	69
Control Keys/Buttons	69
Chassis	69
Sheet Metal Cover	69
Air Ventilation Slots	69
I/O Connector	69
AC Power Cord	69

This page intentionally left blank

Front and Rear Panels

Cleaning

- Do not use any solvents or abrasive cleaners on the any of the panels (including the LCD display).
- Do not spray any cleaning product directly on the panels.

To remove dust, first try gently dusting with a microfiber cleaning cloth. If further cleaning is needed, apply a small amount of screen cleaner to a soft microfiber cloth. Then, clean the panels/LCD display with the moistened cloth.

Screen Cleaning Solutions:

Make your own: Mix distilled water and white vinegar in 1 to 1 proportions. Pour this mixture into a spray bottle from which it can be used, or

Buy a cleaning solution: There are several on the market suitable for cleaning LCD screens.

- Do not spray or apply cleaner directly on the generator.
- Do not allow any liquid to collect around the AC power switch.

Display

Do not apply any pressure to the display.

Control Keys/Buttons

Control keys/buttons will respond to firm, gentle finger pressure. Please do not use sharp objects on the keys/buttons.

Chassis

Sheet Metal Cover

The cover is preformed to fit over the chassis and has protective grills over the cooling air vents. Keep the cover on at all times because there are high voltages present which could cause injury. The internal case also contains capacitors which continue to hold a high electrical charge, even after the power is shut off.

Air Ventilation Slots

Keep the ventilation slots free from obstructions. If excessive dust or dirt collects on the slots, wipe or vacuum them clean. Do not use compressed air to clean them as this may force the dirt inside the chassis.

Allow 5 inches (127 mm) of clearance outside each ventilation slot.

The air intake is on the right, and the exhaust is on the left. This is shown in Figure 3-3, Page 15.

I/O Connector

The Input/Output connector has a pair of 4-40 threaded jack screws to secure the connector. Make sure the screws are snug, but **do not overtighten them.**

AC Power Cord

The AC power cord should be kept in good condition and free from any cuts. The AC plug should be straight with no bent prongs.

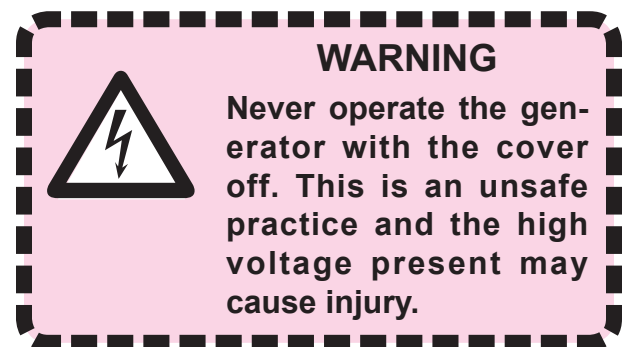

This page intentionally left blank

SECTION 10

Options

Power Inlet Options	73
120V Systems for North American and Japan	73
Electrical Safety	73
120V Power Ground	73
AC Power Inlet Panel	74
AC Power Cord	74
Power Switch/Circuit Breaker	74
Chassis Ground Stud	74
I/O Panel Options	75
Single Connector System I/O Panel	75
Option Panel Modules	76
Multi-Probe Control (MPC) Interface Option	76
Remote Amplitude Control Module	82
Automation Thruster Control Module	84
Isolated I/O Conversion Module	85
<i>iQLinQ</i> [™]	89
<i>iQLinQ</i> RS-232 Interface Option	89
<i>iQLinQ</i> PROFIBUS Communications Module	90
<i>iQLinQ</i> EtherNet/IP [™] Module	91

This page intentionally left blank

This section of the User's Manual provides a general overview of some options/upgrades, all of which are subject to availability, for the basic ultrasonic generator:

Power Inlet Options

120V Systems for North America and Japan

120V systems for North America and Japan have a fixed (non-detachable) power cord.

This option is available on generators with power ratings of 1200 watts or less and with operating frequencies of 20kHz, 30kHz, or 40kHz.

See Table 11-II in *Section 11, Specifications*.

Electrical Safety

120V Power Ground

For safety, the power cords used on all Dukane products have a three-prong, grounding-type plug.

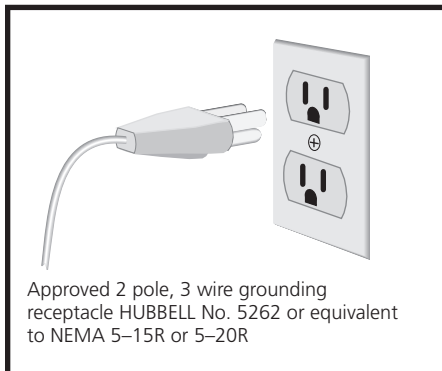

Figure 10-1 Example of 120 Volt, Grounded, 3-Prong Receptacle

CAUTION



If you have a two-prong electrical receptacle, we strongly recommend that you replace it with a properly grounded three-prong type. Have a qualified electrician replace it following the National Electric Code and any local codes and ordinances that apply.

CAUTION



If there is any question about the grounding of your receptacle, have it checked by a qualified electrician. Do not cut off the power cord grounding prong, or alter the plug in any way. If an extension cord is needed, use a three-wire cord that is in good condition. The cord should have an adequate power rating to do the job safely. It must be plugged into a grounded receptacle. Do not use a two-wire extension cord with this product.

AC Power Inlet Panel

The optional AC power inlet panel is described here.

AC Power Cord

The AC power cord (A in Figure 10-2) is appropriately rated and permanently mounted to the power inlet panel.

Power Switch/Circuit Breaker

The power switch/circuit breaker (B in Figure 10-2) has a rocker type actuator switch that will activate or deactivate the AC power to the system. The power ON position is marked with the internationally recognized I symbol, the power OFF position is marked with the 0 symbol. This power switch also integrates an appropriately sized over-current protection circuit breaker function in the generator.

If an over-current condition trips the circuit breaker, it will automatically switch to the OFF position. If the overload current that caused the circuit breaker to trip is due to a transient condition, the circuit breaker can be reset by switching the actuator back to the ON position. If when resetting the circuit breaker after it has tripped, it immediately trips again, there is likely an internal system malfunction, and the generator will require service.

Do not repeatedly try to reset the circuit breaker. If it trips, this will only cause more damage to the generator.

Chassis Ground Stud

The chassis ground stud is used to attach a protective earth ground to the generator. This will aid in the suppression of electrical interference or radio frequency interference (RFI) that is common in an industrial environment. The chassis ground stud is C in Figure 10-2. Proper system grounding is discussed in *Section 3*.

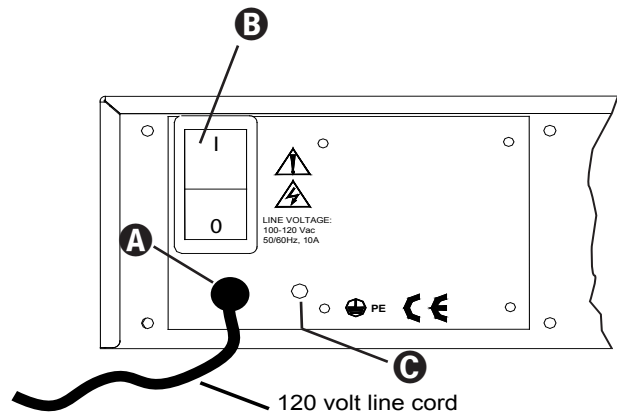

Figure 10-2 120VAC Power Inlet Panel

I/O Panel Options

Single Connector System I/O Panel

See **B** in Figure 10-4 where the I/O panel is set up for the single I/O connector, a HD15F type. The generator label for this connector is, SYSTEM INPUTS/OUTPUTS. Another label identifies the connector as J12.

The I/O panel can be customized with multiple types of connectors such as the single HD15F, terminal blocks, etc. Contact your local sales representative for more details.

Table 10-I shows an example of a customized option: Pins/Signals duplicate a Dukane DPC-I generator.

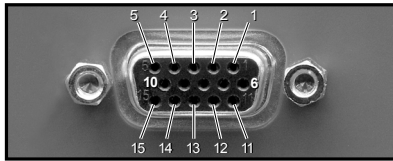

Figure 10-3 HD15F for System Inputs/Outputs Connector

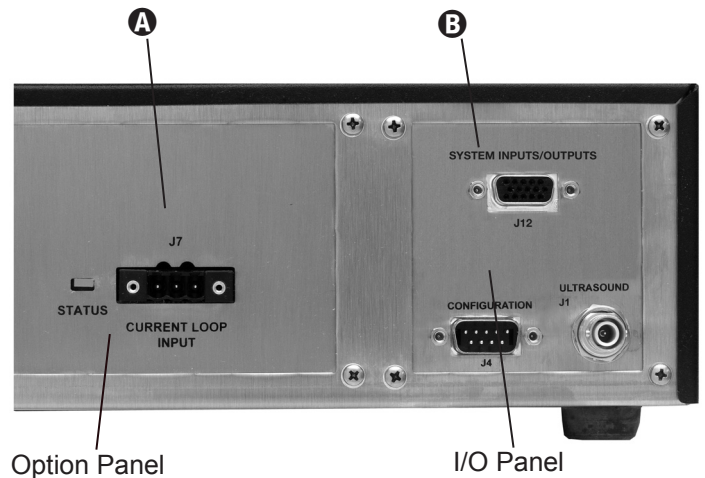

Figure 10-4 Option Panel and I/O Panel (NOTE: Shown are the Option panel with Remote Control Module, and the I/O panel with single I/O connector.)

Pin	Signal Name	Signal Description
1	+22VDC	Current limited to 250mA maximum
2	Ground	22VDC Return (chassis ground)
3	Ground	Status Outputs/Driver/Monitor Return
4	Status Driver	Status Driver Output (1 Amp max.)
5	Ultrasound Active Status	Ultrasound Status Output (Active Low)
6	Overload Fault Status	Overload Fault Output (Active Low)
7	Isolated Operate Input Common	Isolated Operate Input Common (7 & 8) JU726
8	Operate Input	Sw Closure Operate Inut (2 & 8) JU724/725
9	Over Temperature Fault	Over Temperature Fault Output (Active Low)
10	System Fault	System Fault Output (Active Low)
11	Not Used	Reserved - HPPI Signal
12	Amplitude Setting	Amplitude Setting Monitor (10.0V = 100%)
13	Power Signal Common	Power Signal Common
14	Power Signal	Power Signal Monitor Output (1mV = 1 Watt)
15	Loop Fault	Current Loop Fault Output (Active Low)

Table 10-I HD15F Example of Customized System Inputs/Outputs Connector Signals

Option Panel Modules

A single optional module can be installed in the *iQ* generator's Option Module Panel. See **A** in Figure 10-4 where the option panel is set up for a Remote Control Module.

Multi-Probe Control (MPC) Interface Option Part Number - 110-4251

The *iQ* generator can be configured with an optional MPC Interface circuit board that powers and controls an external MPC multi-probe control module. This external module, (that can be ordered with a minimum of two probe controls up to a maximum of 16 probe controls), must be purchased

Optional MPC Interface Connections

Complete Steps 1 - 4 of the basic connections as described on Pages 19-20. These involve:

- Grounding (optional),
- Ultrasound Output,
- System Control Inputs/Status Outputs, and
- AC Line Input.

In addition to completing these first four Steps, complete Steps 5 and 6 to wire the MPC Control Inputs/Status Outputs as described below.

Details about the various system connectors and their pin assignments are covered below.

Step 5. MPC I/O - MPC control/input signals and status output signals are carried in the I/O cables that should already be connected - See Inputs (J2) and Outputs (J3) in Figure 10-5.

Step 6. MPC INTERFACE - Attach one end of the MPC Interface cable (Dukane # 200-1408-XX) to the MPC Interface connector on the *iQ* generator panel - MPC INTERFACE in Figure 10-5. Connect the other end of the cable to the MPC INTERFACE connector on the right rear of the MPC module.

NOTE

The MPC Interface cable is a separate line item on the *iQ* generator system order. The -XX at the end of the cable number specifies cable length. This will vary depending on your MPC installation.

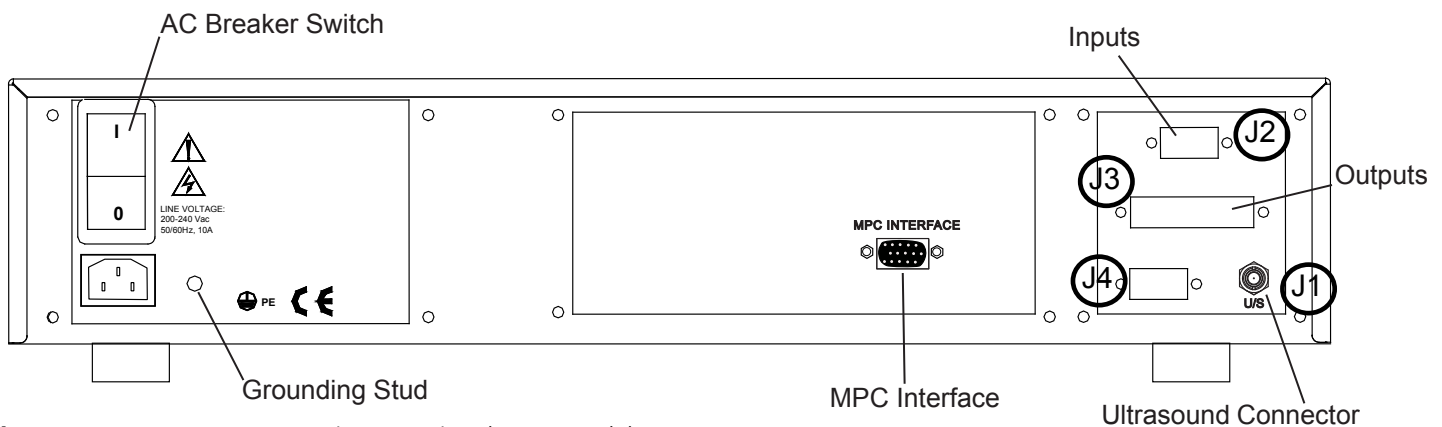

Figure 10-5 Generator Rear View - Optional MPC Model

See NOTE on the MPC cable above.

See NOTE on Page 77.

MPC I/O Connections

Signal names and Pin numbers and the connectors related to the MPC option are shown in the table below. See the pages referred to in the table for more information about the signals.

Pin	Signal Name	Connector
3	Setup Bit 0 Input	J2 (Page 20)
4	Setup Bit 1 Input	
5	Setup Bit 2 Input	
6	Setup Bit 3 Input	
18	MPC Ready Out	J3 (Page 25)

Table 10-II MPC I/O Connector Signals

MPC Probe Control

When the optional MPC Interface and MPC I/O connectors are used, the generator has the capability of controlling as many as sixteen compatible probes. One probe can be turned on at a time while the sequence of probe activation is determined by the user's automation. The table below shows how the setup bit inputs correspond to the probes.

MPC				Probe Selected
3	2	1	0	
Off	Off	Off	Off	1
Off	Off	Off	On	2
Off	Off	On	Off	3
Off	Off	On	On	4
Off	On	Off	Off	5
Off	On	Off	On	6
Off	On	On	Off	7
Off	On	On	On	8
On	Off	Off	Off	9
On	Off	Off	On	10
On	Off	On	Off	11
On	Off	On	On	12
On	On	Off	Off	13
On	On	Off	On	14
On	On	On	Off	15
On	On	On	On	16

Table 10-III MPC Setup Bit Inputs

NOTE

Ultrasound Output Connector

The ultrasound output connector used with all standard generators is a high voltage (5000V) coaxial style SHV-BNC connector. This connector provides superior shielding of electrical noise, compared to other types of connectors. The ultrasound output connector mates with fully shielded coaxial ultrasound cables that are secured with a simple and reliable quarter-turn bayonet style attachment mechanism.

The ultrasonic output from this connector (that drives the attached ultrasonic load) is a very high AC voltage. At high power levels this can exceed 2 amps of current and must be securely terminated via the ultrasound cable for safe operation. Use original equipment ultrasound cables for safe and reliable system operation. Improperly assembled ultrasound cables can result in high voltage arcing and will destroy the ultrasound connectors.

MPC Interface Installation Guide

The MPC interface is designed for assembly systems where one ultrasonic generator is sequenced to as many as 16 ultrasonic probes.

The MPC interface is typically supplied as a stand-alone bench-top unit, or as a component that can be mounted in a through-panel configuration.

No special installation is needed for a stand-alone MPC interface that can be put on a bench top or a shelf.

Use the following installation recommendations for a panel mounted MPC interface.

Cut Outs

For panel mounted modules:

Use Figure 10-6 below to determine the size of the cutout needed for your equipment panel.

Make the appropriate cut, and install the MPC interface securing the mounting flange to the equipment panel before continuing with the cable connections.

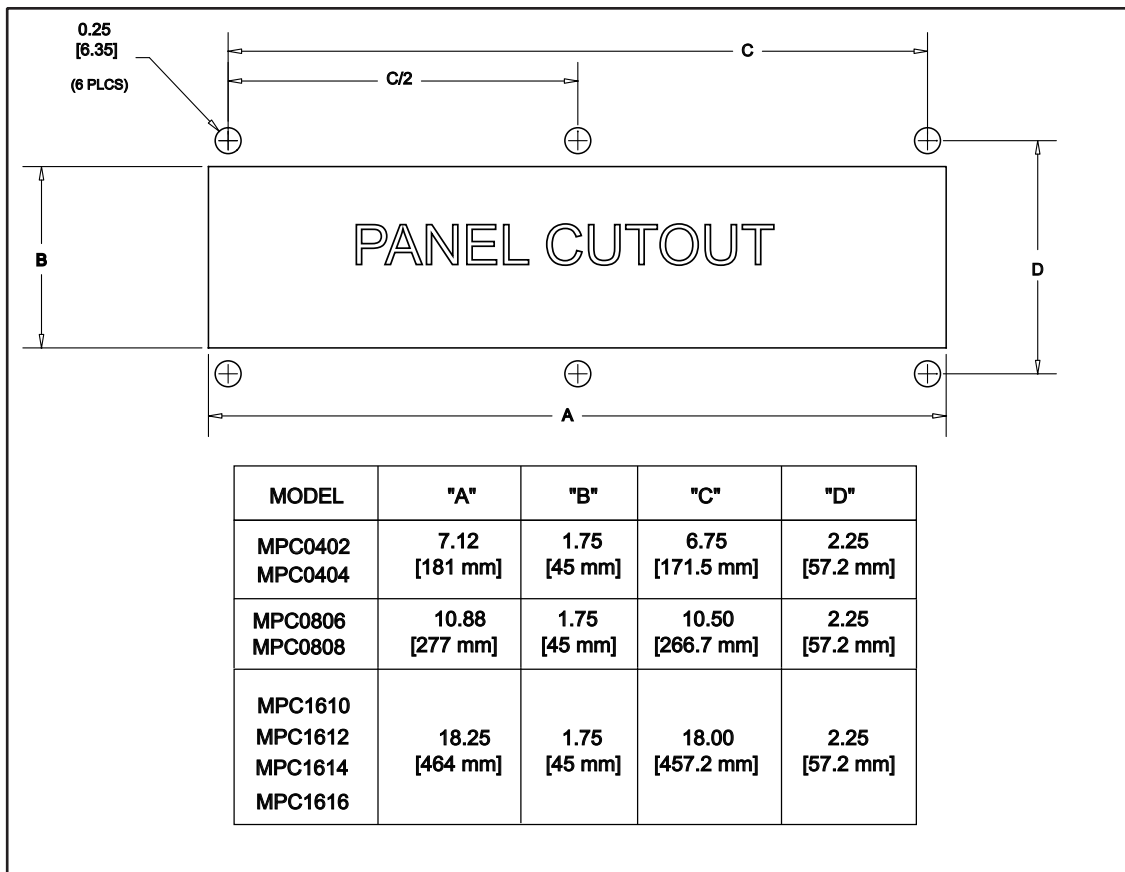

Figure 10-6 MPC Module Cutout Guide

Connecting Cables

For stand-alone interfaces and securely installed panel mounted interfaces:

Rear Connections

Refer to Figure 10-7 below, and complete these connections.

1. Earth ground - Connect one end of a user-supplied 14-Gauge ground wire to the ground connection at the rear of the MPC, **A** in Figure 10 -7. Connect the other end of the wire to an earth ground potential at the electrical box that supplies power to the equipment (or to the equipment enclosure into which your system is installed).
2. U/S (ultrasonic) cable (Dukane P/N 200-479-XX - Order the correct cable length for your installation.) - Connect one end of the cable to the left rear U/S connector of the MPC interface, **B** in Figure 10 -7. The other end of the cable connects to J1 of the ultrasonic generator.
3. MPC Interface cable (Dukane P/N 200-1408-XX - Order the correct cable length for your installation.) - Connect one end of the cable to the right rear MPC Interface connector, **C** in Figure 10 -7. The other end of the cable connects to the MPC INTERFACE connector on the ultrasonic generator.

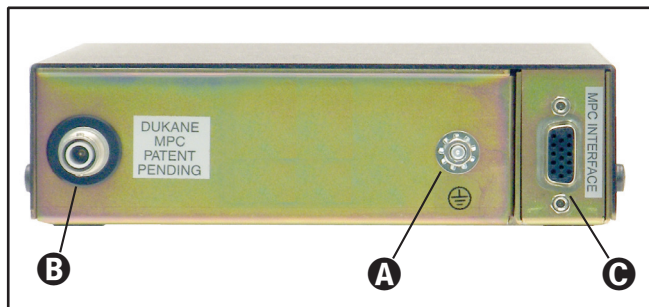

Figure 10-7 MPC Interface Rear Connectors

Front Connections

Refer to Figure 10-8 below.

Complete these connections.

1. Probe Cable(s) - Beginning with PROBE 1, connect one end of the cable (See Table 10-IV below.) to the U/S connector on the MPC's front panel, **D** in Figure 10 -7. Connect the other end of the cable to the corresponding probe for your specific welding application.
2. Repeat Step 1 for each of the remaining probes (in sequence: 2, 3, 4, etc.) in your system.

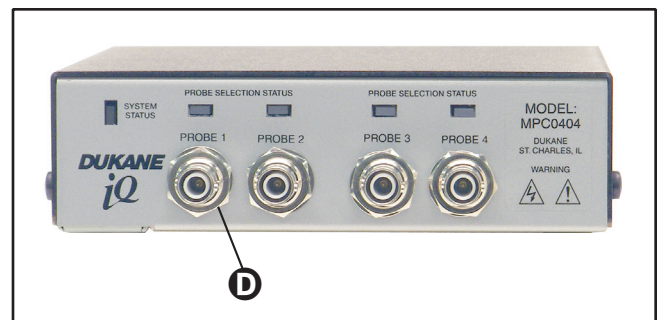

Figure 10-8 MPC Interface Front Connectors

System Frequency	Probe P/N	Cable P/N : MPC to Probe
20kHz	41C25	200-479-XX
	41C27	
30kHz	41A60R-129	200-615-XX
40kHz	41A40	

Table 10-IV Probe Cables

MPC Interface Status LEDs

System Status

When the system is powered and ready, the front panel SYSTEM STATUS LED lights up, and becomes GREEN (E in Figure 10-9).

If this LED is lit with a YELLOW/ORANGE color, a recoverable fault condition has tripped. This indicates that the system is operational, but a fault condition has occurred preventing normal operation. Examples of this type of fault would be a generator overload that will automatically reset when the next weld cycle begins, or the automation control system is selecting a channel that doesn't exist - for instance, trying to select channel 10 for an 8 channel system

If this LED lights up RED, a hardware fault has been sensed, and the unit should be returned to Dukane for servicing.

Probe Selection Status

The PROBE SELECTION STATUS LED (F in Figure 10-9) lights up GREEN indicating it is the selected probe.

A probe's LED turns to RED (from GREEN) when ultrasonic power is activated.

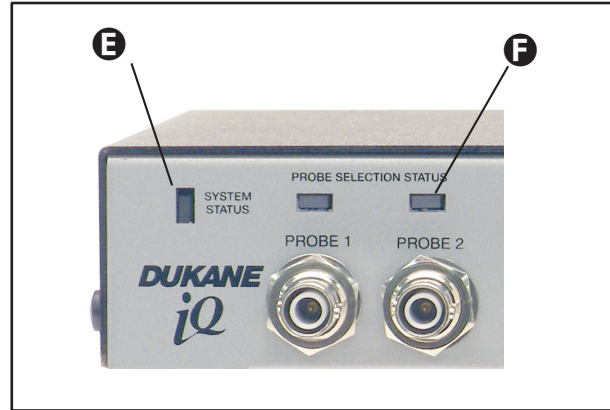

Figure 10-9 MPC Interface Status LEDs

MPC Cycle Illustration

The flow chart below illustrates a typical welding cycle when the MPC feature is used.

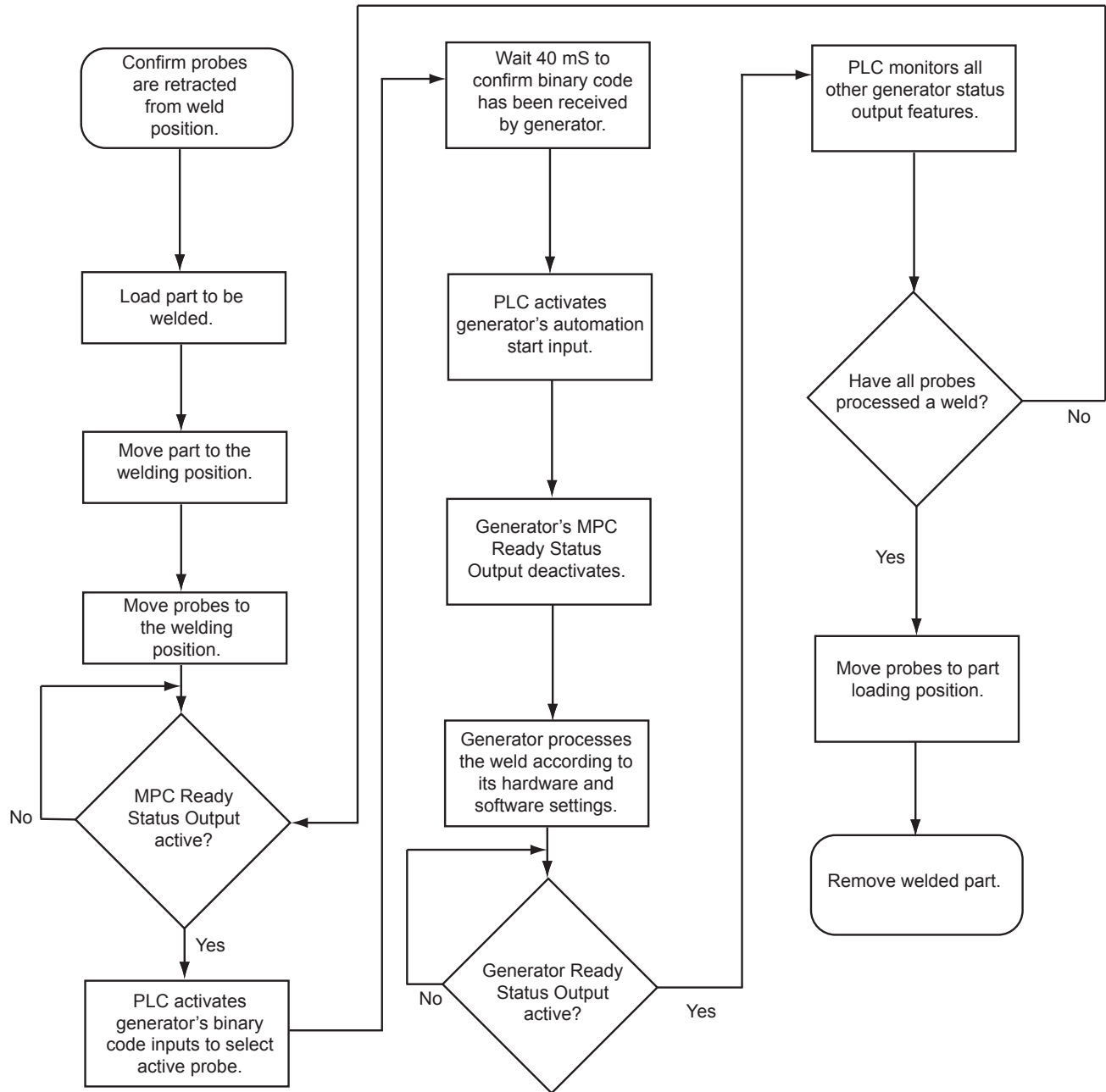

Figure 10-10 MPC Cycle Flow Chart

Remote Amplitude Control Module

Part Number - 110-4183

This optional module enables remote control of output amplitude of the iQ system. The control interface is a 4–20mA current loop. The current loop connector and fault indicator are shown below in Figure 10–12. The output can be adjusted from 36% to 100%. The scale factor is a 4% amplitude change for each mA change. A graph of amplitude output as a function of loop current is shown in Figure 10-11. The current loop compliance voltage is 6 volts minimum.

Failure to provide at least 4mA of loop current is sensed as a fault and will produce minimum amplitude output.

The current loop fault indicator is a bi-color LED. It is green when the current is between 4 and 20mA and red when the current is below 2mA.

Current Loop Fault

If a current loop source is not available, an external +24VDC power supply can be connected to the POS and NEG terminals of J7. (See Figure 10-12.) A +22VDC supply is also available on System Output Pins 1(+) and 3(-).

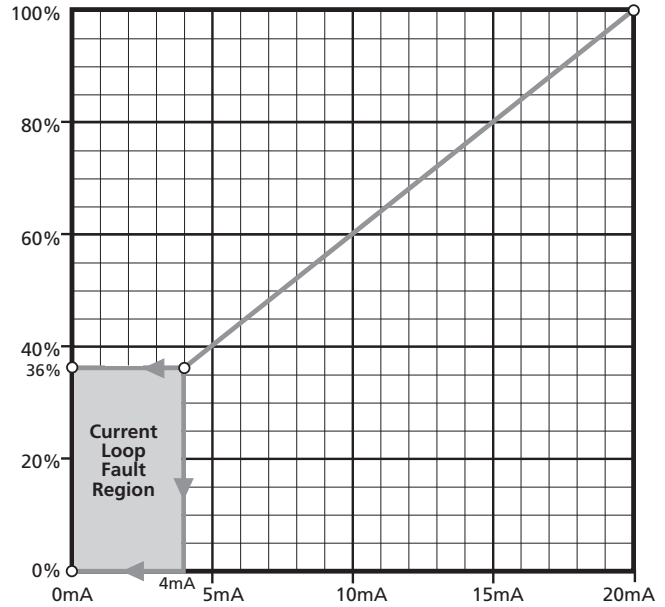

Figure 10-11 Current Loop Transfer Function Graph

Future Availability

In the future, Remote Power Regulation Control will become available. This option module will be able to remotely control the power regulation setpoint using new user-selection menu choices made from the front panel.

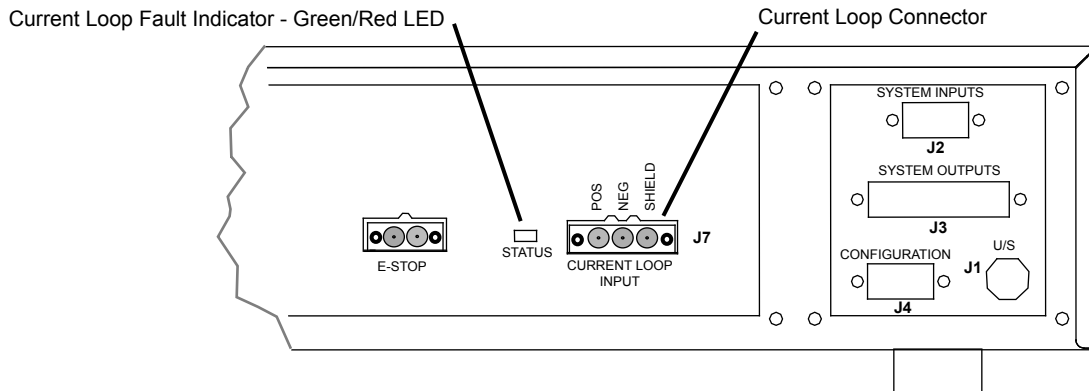

Figure 10-12 Remote Amplitude Control Module

Menu Selections

With the optional Remote Amplitude Control Module installed, the generator detects the module. As a result there is an additional menu to consider:

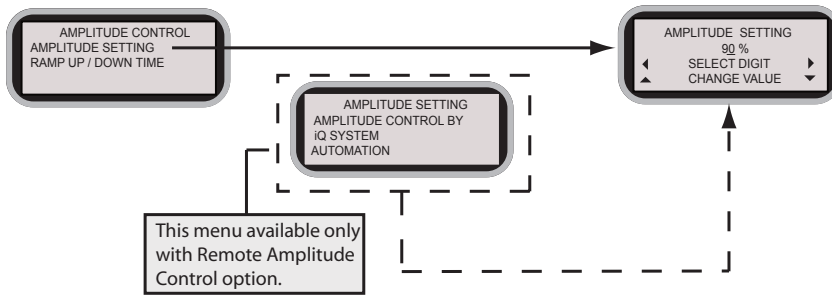

Figure 10-13 Amplitude Control Menu Detail

See Figure 10-13 above.

If **IQ SYSTEM** is selected, the amplitude setting is adjusted with the front panel user interface.

If **AUTOMATION** is selected for amplitude control, the amplitude setting is adjusted with the 4-20mA current loop.

Automation Thruster Control Module

Part Number - 110-4206

This optional module enables the *iQ* system to control a Dukane *iQ* thruster. The module is illustrated in Figure 10-14. Check your thruster operator's manual for cable connection information.

J5 is the HD-26 pin basic thruster connector and J6 is a DB-9 abort switch connector. Figures 10-15 and 10-16 identify pin numbers for J6 and J5, respectively.

The Automation Thruster Control Input (J2 pin 9) is used to control the up and down movement of the thruster. If this input is deactivated (default), the thruster will remain in the up position. When the input is activated,

the thruster will descend to the down position at a speed that is determined by the pressure regulator setting on the front of the thruster.

NOTE

It is the responsibility of the machine builder to ensure that all appropriate safety regulations are met when using the Thruster Control Module in an automated system. A light curtain or similar safety guarding should be used to prevent operator injury.

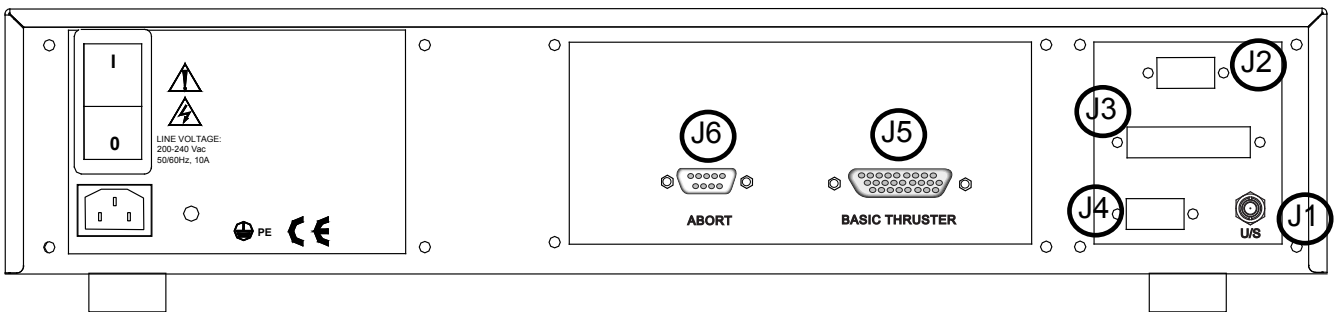

Figure 10-14 Automation Thruster Control Module

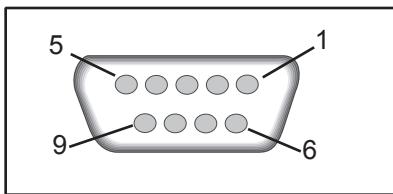

Figure 10-15 DB-9 Connector with Pin Locations (J6)

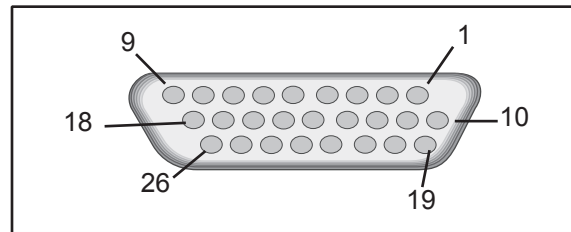

Figure 10-16 HD-26 Connector with Pin Locations (J5)

Pin No.	Input/Output	Function	Signal Types
1			Not Used
2			Not Used
3	Input	Hardware Abort Power In	Normally closed emergency switch contact
4	Input	Software Abort	Normally open dry contact switch closure to ground
5		Press Inhibit (Gnd)	Safety signal
6			Not Used
7	Ground	Ground	Internal ground
8			Not Used
9	Output	Hardware Abort Power Out	Normally closed emergency switch contact

Table 10 - V Abort Connector Pinout (J6)

To enable the thruster, Pins 3 and 9 must be shorted together through a safety circuit (see Table 10-V) during normal operation.

During an abort or emergency stop condition, the connection between Pins 3 and 9 must open to disable movement of the thruster. In addition to opening the connection between Pins 3 and 9, Pins 4 and 7 must be shorted together to alert the process controller of the condition.

The accessory cable for J5 is Part No. 200-1413-XX.

The accessory cable for J6 is Part No. 200-1546-XX (where XX is a length designation).

Isolated I/O Conversion Module

Part Number - 110-4397

The Isolated I/O Conversion Module is a solid-state, DIN rail-mounted module that can be used to convert an iQ's NPN (sinking) outputs to PNP (sourcing) outputs.

This module should be used in place of relays if the mechanical life of relays in the automated machine is a concern. Each of the four channels are completely isolated from each other and can also be used to convert PNP signals to NPN, or to convert +5V TTL signals to +24V levels.

Examples

Three examples of conversion possibilities are shown on the pages that follow:

- **NPN to PNP**, Figure 10-17
- **PNP to NPN**, Figure 10-18, and
- **+5V to +24 V PNP**, Figure 10-19

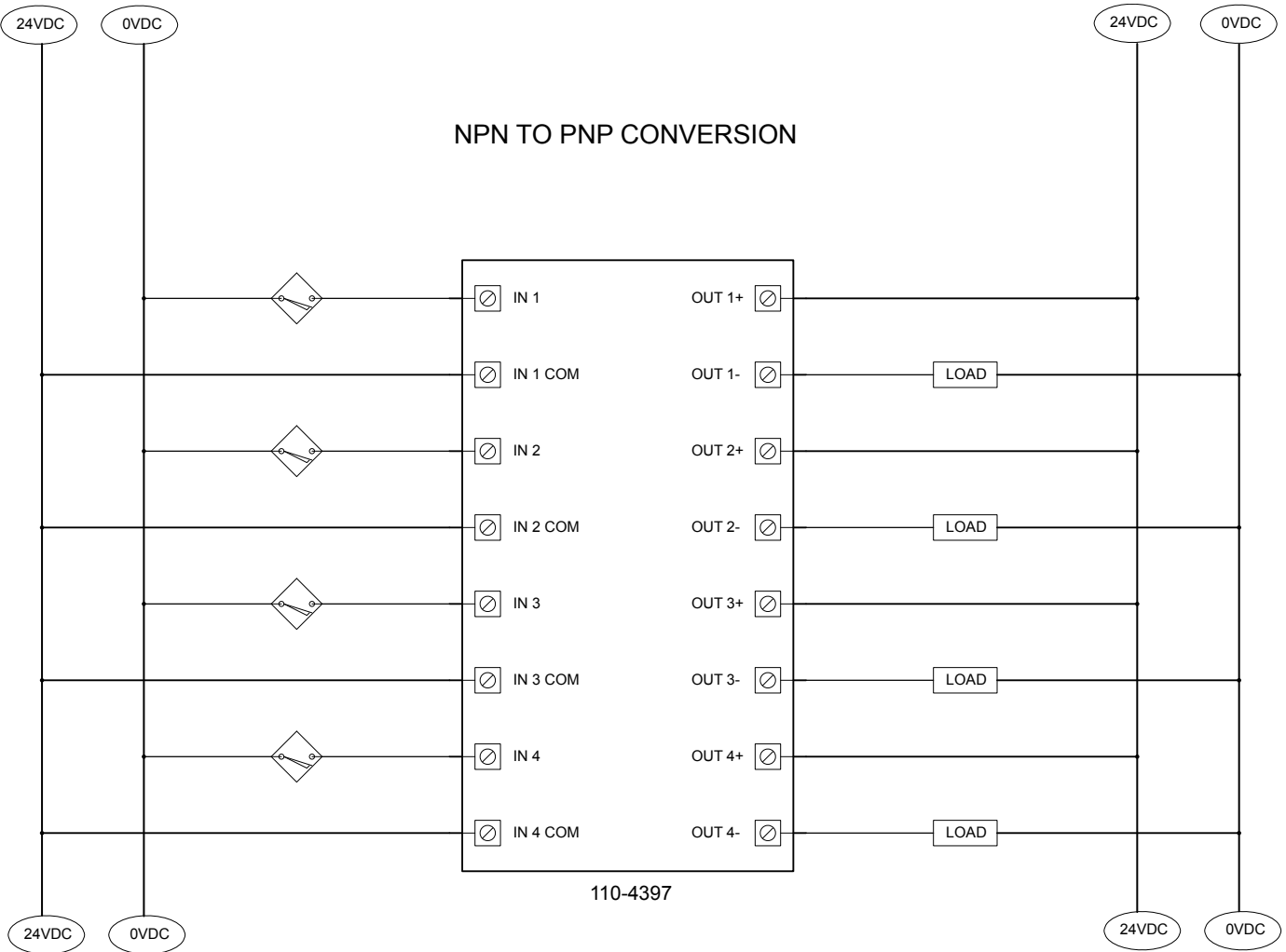

SPECIFICATIONS:

INPUTS:

MINIMUM VOLTAGE: 5.0 Vdc
 MAXIMUM VOLTAGE: 30.0 Vdc
 CURRENT: 1.5mA @ 5.0 Vdc / 9.5mA @ 24.0 Vdc

OUTPUTS:

MINIMUM VOLTAGE: 5.0 Vdc
 MAXIMUM VOLTAGE: 30.0 Vdc
 MAXIMUM CURRENT: 50mA
 VOLTAGE DROP (+ TO -): 1.0 Vdc MAX

NOTES:

- 1: OUTPUTS SHOULD NOT BE CONFIGURED TO SINK A TTL LOAD TO GROUND. A RELAY CONNECTION SHOULD BE USED INSTEAD.

Figure 10-17 NPN to PNP Conversion

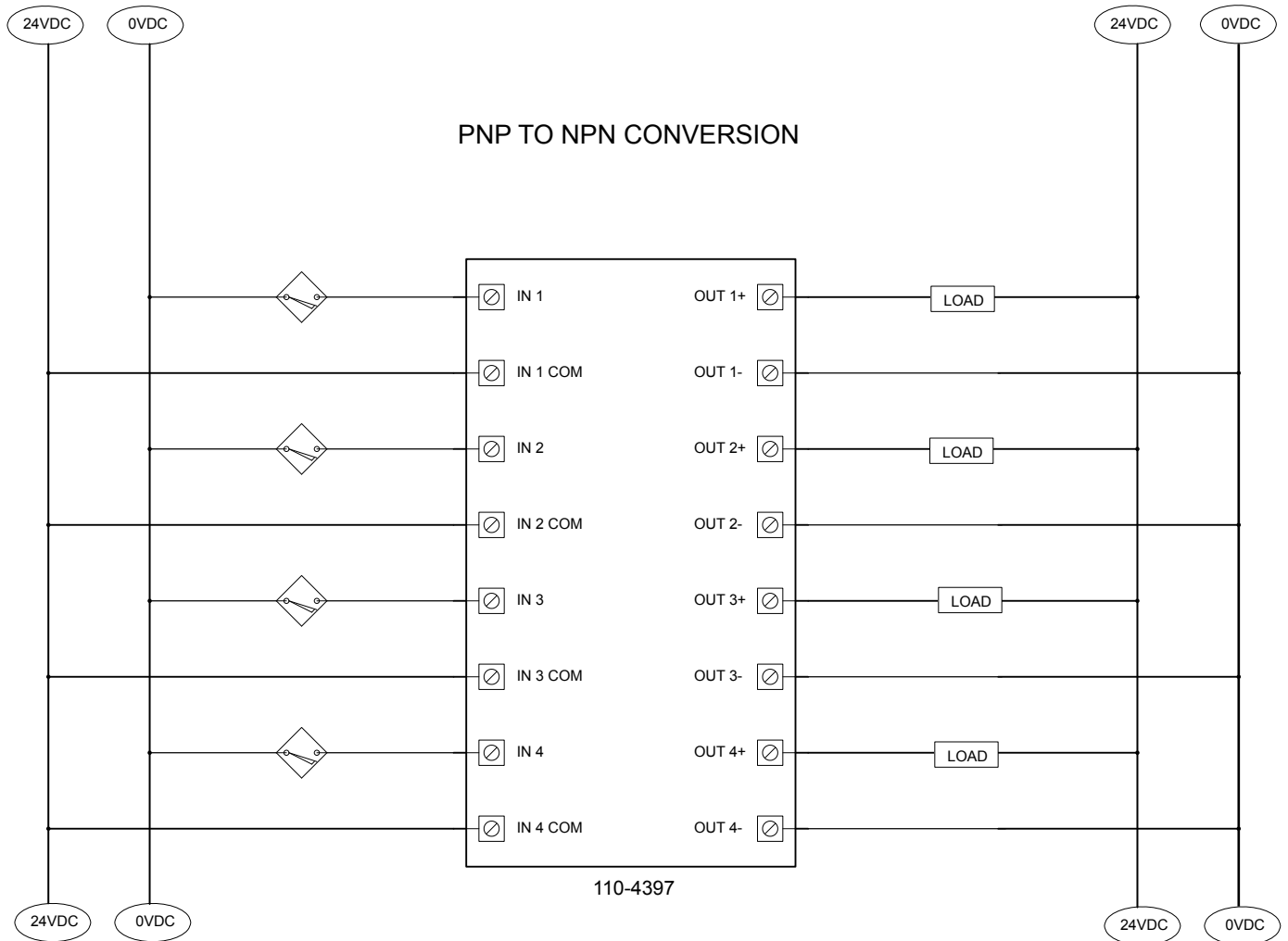
**SPECIFICATIONS:****INPUTS:**

MINIMUM VOLTAGE: 5.0 Vdc
 MAXIMUM VOLTAGE: 30.0 Vdc
 CURRENT: 1.5mA @ 5.0 Vdc / 9.5mA @ 24.0 Vdc

OUTPUTS:

MINIMUM VOLTAGE: 5.0 Vdc
 MAXIMUM VOLTAGE: 30.0 Vdc
 MAXIMUM CURRENT: 50mA
 VOLTAGE DROP (+ TO -): 1.0 Vdc MAX

NOTES:

1: OUTPUTS SHOULD NOT BE CONFIGURED TO SINK A TTL LOAD TO GROUND. A RELAY CONNECTION SHOULD BE USED INSTEAD.

Figure 10-18 PNP to NPN Conversion

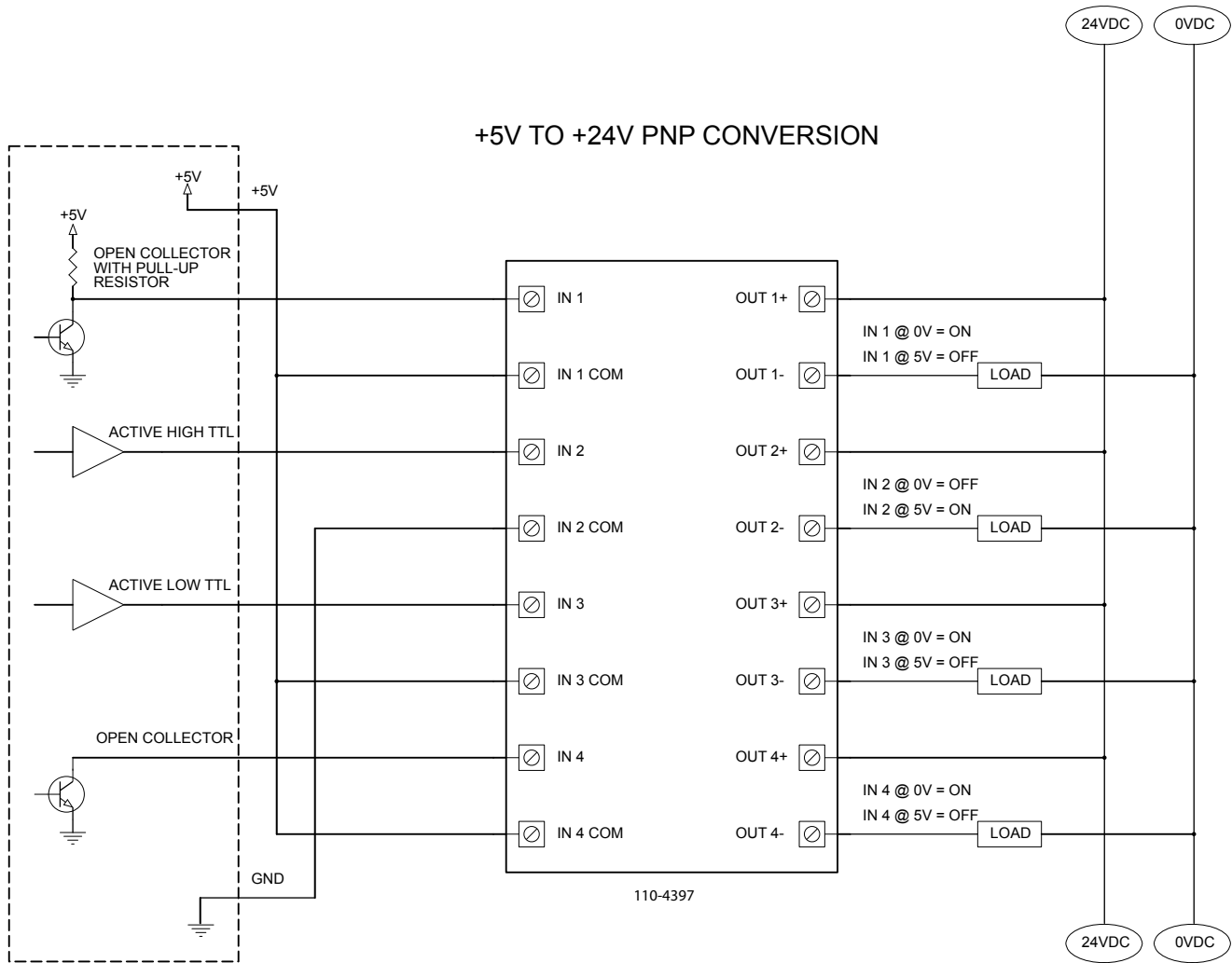

SPECIFICATIONS:

INPUTS:

- MINIMUM VOLTAGE: 5.0 Vdc
- MAXIMUM VOLTAGE: 30.0 Vdc
- CURRENT: 1.5mA @ 5.0 Vdc / 9.5mA @ 24.0 Vdc

OUTPUTS:

- MINIMUM VOLTAGE: 5.0 Vdc
- MAXIMUM VOLTAGE: 30.0 Vdc
- MAXIMUM CURRENT: 50mA
- VOLTAGE DROP (+ TO -): 1.0 Vdc MAX

NOTES:

- 1: OUTPUTS SHOULD NOT BE CONFIGURED TO SINK A TTL LOAD TO GROUND. A RELAY CONNECTION SHOULD BE USED INSTEAD.

Figure 10-19 +5V to +24V PNP Conversion



iQLinQ communication options allow automated systems to monitor and change settings in *iQ* generators. These options provide machine builders the ability to integrate the generator into an electrical cabinet and to use the machine's HMI to program or monitor weld settings.

All Dukane *iQ* LS generators include the RS-232 Interface option, which can be used to set amplitude and monitor power. Using this option avoids adding expensive analog cards into PLC racks. *iQLinQ* also provides a cost effective solution for adding the Weld by Energy feature that is only available in the more advanced *iQ* generators. In addition to RS-232, *iQLinQ* is also available for PROFIBUS and Ethernet/IP™.

iQLinQ solutions are available to provide complete ladder logic and HMI screens that can be dropped into Allen Bradley (RSLogix 5000) and Siemens (Step 7) PLC projects.

Contact your local Dukane representative for more information about the *iQLinQ* options.

***iQLinQ* RS-232 Interface Option**

The RS-232 Interface option allows the *iQ* generator to connect to a PLC's serial port. Each generator requires a dedicated connection to automation, so it is not possible to daisy-chain or bus multiple generators on a single RS-232 connection.

Control Parameters Available via RS-232

(Time [only] option)

1. Set these parameters: Weld Time, Amplitude, Ramp Up Time, and Ramp Down Time.
2. Configure advanced hardware settings including Phase, Free Run Frequency, Frequency Lock and Hold, and Frequency Limits.

Parameters that can be Obtained via RS-232

(Time [only] option)

1. All control parameters that are configured via RS-232.
2. Real time data that includes welder state (ultrasound active or not), frequency, power, and amplitude.

Control Parameters Available via RS-232

(Time and Energy option)

1. Set weld method to Time, Energy, or Peak Power. set associated values in seconds, joules, or watts.
2. Set Amplitude, Ramp Up Time, and Ramp Down Time.
3. Enable and set Trigger by Power parameters.
4. Enable and set Hold Time.
5. Enable and set Afterburst delay and duration.
6. Enable checking for Suspect Parts. Set maximum and minimum values for Time, Power and/or Energy.
7. Enable checking for Bad Parts. Set maximum and minimum values for Time, Power and/or Energy.
8. Configure advanced hardware settings including Phase, Free Run Frequency, Frequency Lock and Hold, and Frequency Limits.

Parameters that can be Obtained via RS-232

(Time and Energy option)

1. All control parameters that are configured via RS-232.
2. Real time data that includes welder state (ultrasound active or not), frequency, power, and amplitude.
3. Weld cycle data from previous weld that includes:
 - Cycle Count
 - Good, Bad, and Suspect Part information
 - Process Limit setting exceeded or not reached if Bad or Suspect Part checking is enabled
 - Weld Time
 - Weld Energy
 - Peak Power

For information on how to control and/or monitor specific parameters, *iQ* Generator RS-232 Communication and Control documentation is available.

Signing a non-disclosure agreement is required to obtain this documentation.

iQLinQ™ PROFIBUS Communications Module

Part Number - 110-4554

The PROFIBUS option module allows the *iQ* generator to connect to a PROFIBUS network. Since PROFIBUS is multipoint instead of point-to-point, more than one generator can be connected to a single bus cable. The PROFIBUS module offers access to generator parameter settings and status information listed below. In addition, if desired, all I/O wiring can be replaced with a single PROFIBUS cable.

Control Parameters available via PROFIBUS

1. Set weld method to Time, Energy, or Peak Power. Set associated values in seconds, joules, or watts.
2. Set Amplitude, Ramp Up Time, and Ramp Down Time.
3. Enable and set Trigger by Power parameters.
4. Enable and set Hold Time.
5. Enable and set Afterburst delay and duration.
6. Enable checking for Suspect Parts. Set maximum and minimum values for Time, Power and/or Energy.
7. Enable checking for Bad Parts. Set maximum and minimum values for Time, Power and/or Energy.
8. Configure advanced hardware settings including Phase, Free Run Frequency, Frequency Lock and Hold, and Frequency limits.

Parameters that can be obtained via PROFIBUS

1. All parameters that are configured via PROFIBUS
2. Real time data which includes welder state (ultrasound active or not), frequency, power, and amplitude.
3. Weld cycle data from previous weld which includes:
 - Cycle Count
 - Good, Bad, and Suspect Part information
 - Process Limit setting exceeded or not reached if Bad or Suspect Part checking is enabled
 - Weld Time
 - Weld Energy (Time and Energy option)
 - Peak Power

For information on how to control and/or monitor specific parameters, *iQ* Generator PROFIBUS Communication and Control documentation is available.

Signing a non-disclosure agreement is required to obtain this documentation.

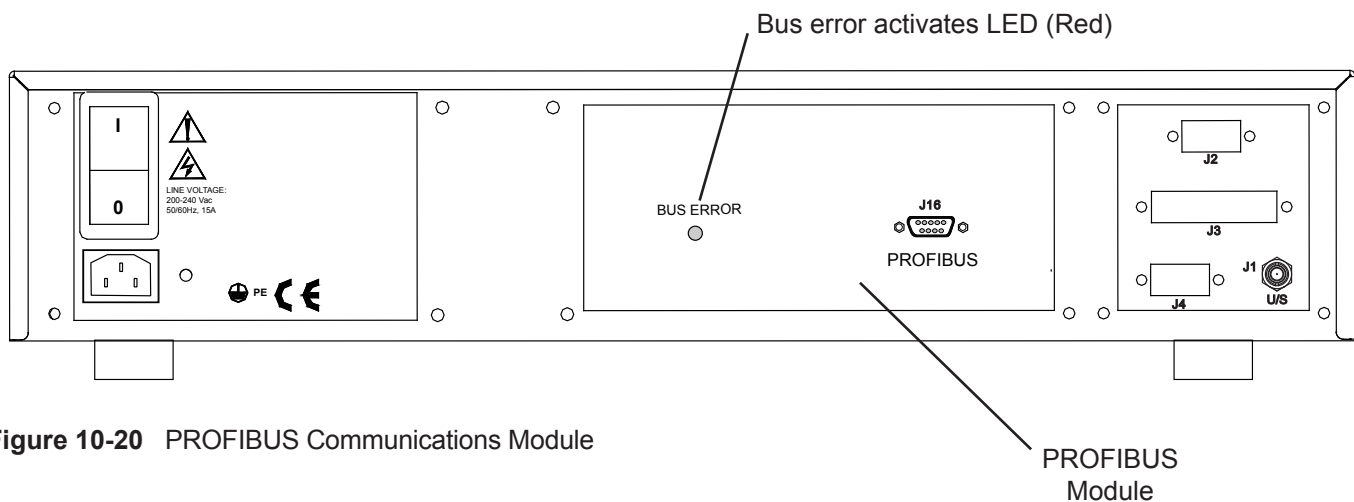

Figure 10-20 PROFIBUS Communications Module

iQLinQ™ Ethernet/IP™ Module**Part Number - 110-4644**

The EtherNet/IP option module allows the *iQ* generator to connect to an EtherNet/IP network. The option module is an external DIN-rail mounted device that acts as a bridge between the automation network and an *iQ* generator's RS-232 port. See Figure 10-21 below.

Control Parameters available via EtherNet/IP

1. Set weld method to Time, Energy, or Peak Power. Set associated value in seconds, joules, or watts.
2. Set Amplitude, Ramp Up Time, and Ramp Down Time.
3. Enable and set Trigger by Power parameters.
4. Enable and set Hold time.
5. Enable and set Afterburst delay and duration.
6. Enable checking for Suspect Parts. Set maximum and minimum values for Time, Power and/or Energy.
7. Enable checking for Bad Parts. Set maximum and minimum values for Time, Power and/or Energy.
8. Configure advanced hardware settings including Phase, Free Run Frequency, Frequency Lock and Hold, and Frequency limits.

Parameters that can be obtained via Ethernet/IP

1. All parameters that are configured via EtherNet/IP.
2. Real time data which includes welder state (ultrasound active or not), frequency, power, and amplitude.
3. Weld cycle data from previous weld which includes:
 - Cycle Count
 - Good, Bad, and Suspect Part information
 - Process Limit setting exceeded or not reached if Bad or Suspect Part checking is enabled
 - Weld Time
 - Weld Energy
 - Peak Power

For information on how to control and/or monitor specific parameters, *iQ* Generator EtherNet/IP Communication and Control documentation is available.

Signing a non-disclosure agreement is required to obtain this documentation.

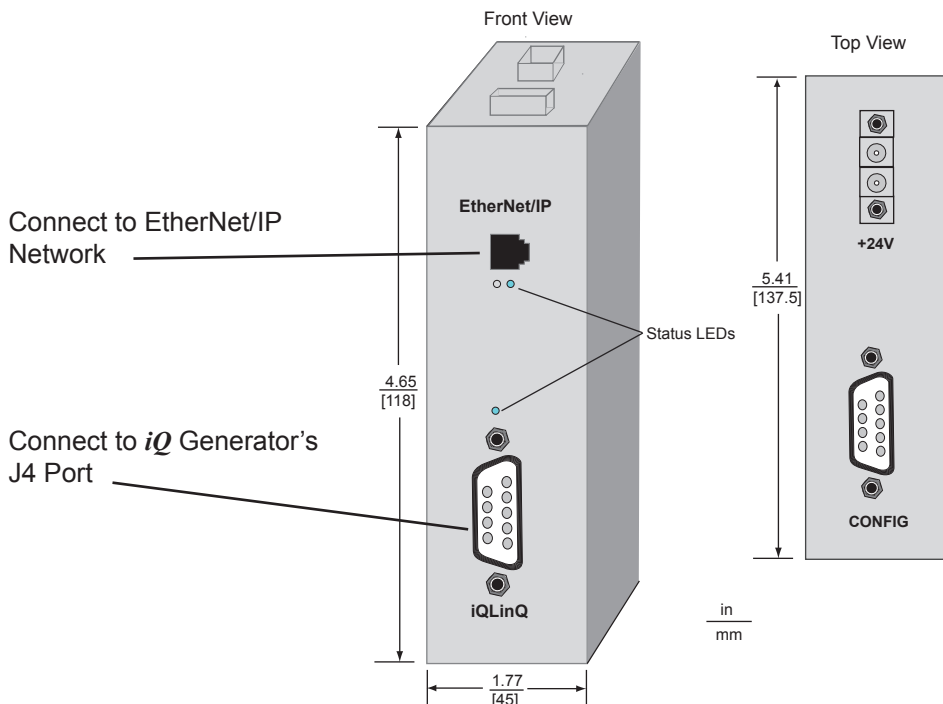

Figure 10-21 EtherNet/IP™ Module

This page intentionally left blank

SECTION 11

Specifications

Drawings.	95
Low Profile Chassis.	95
High Profile Chassis	96
High Power (3600W) Chassis	97
High Power (4800W) Chassis	98
Weight	99
Operating Environment.	99
AC Power Requirements	100
Interpreting the Model Number.	101
Regulatory Agency Compliance	102
FCC	102
CE Marking	102
IP Rating	102

This page intentionally left blank

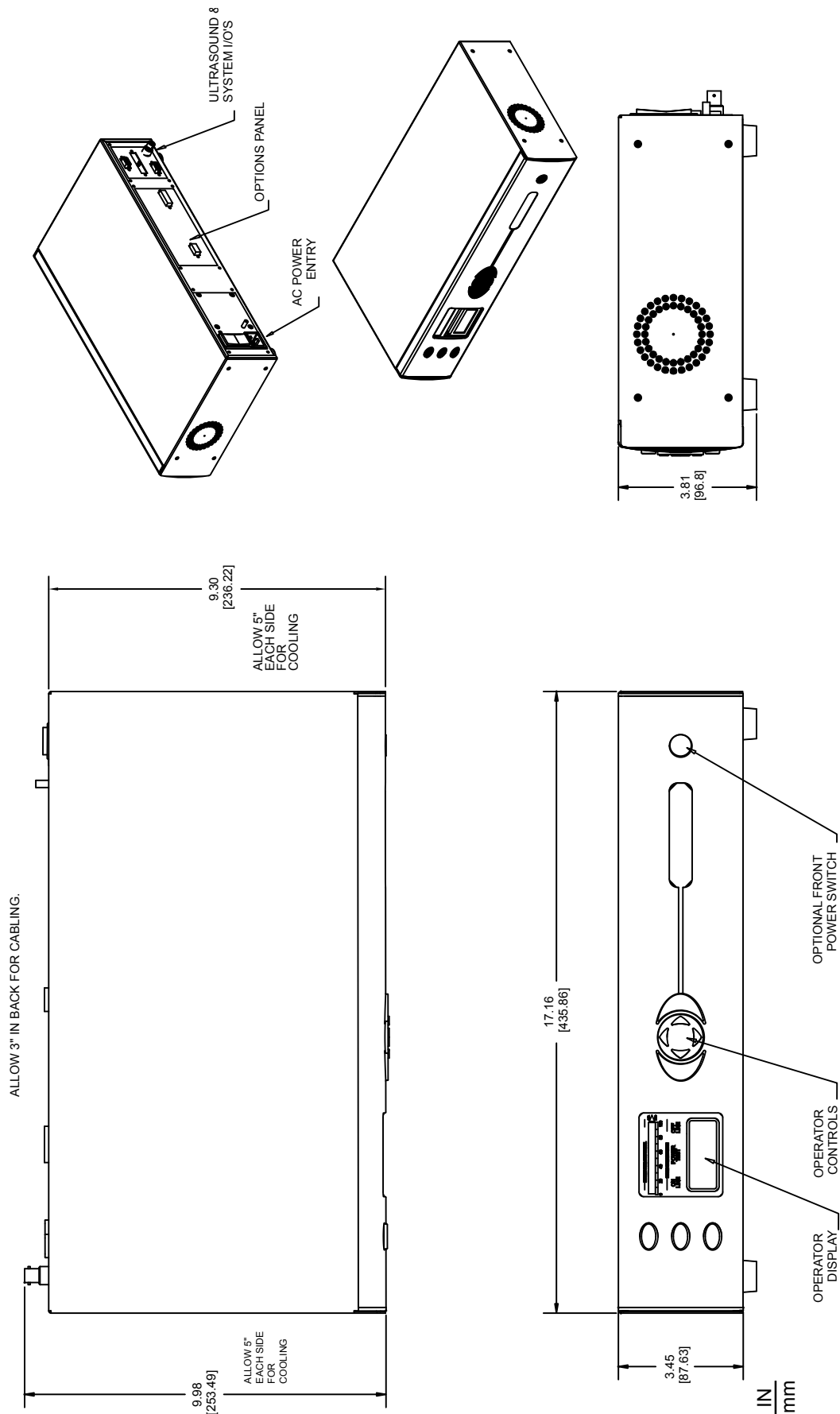

Figure 11-1 Low Profile Chassis Drawing

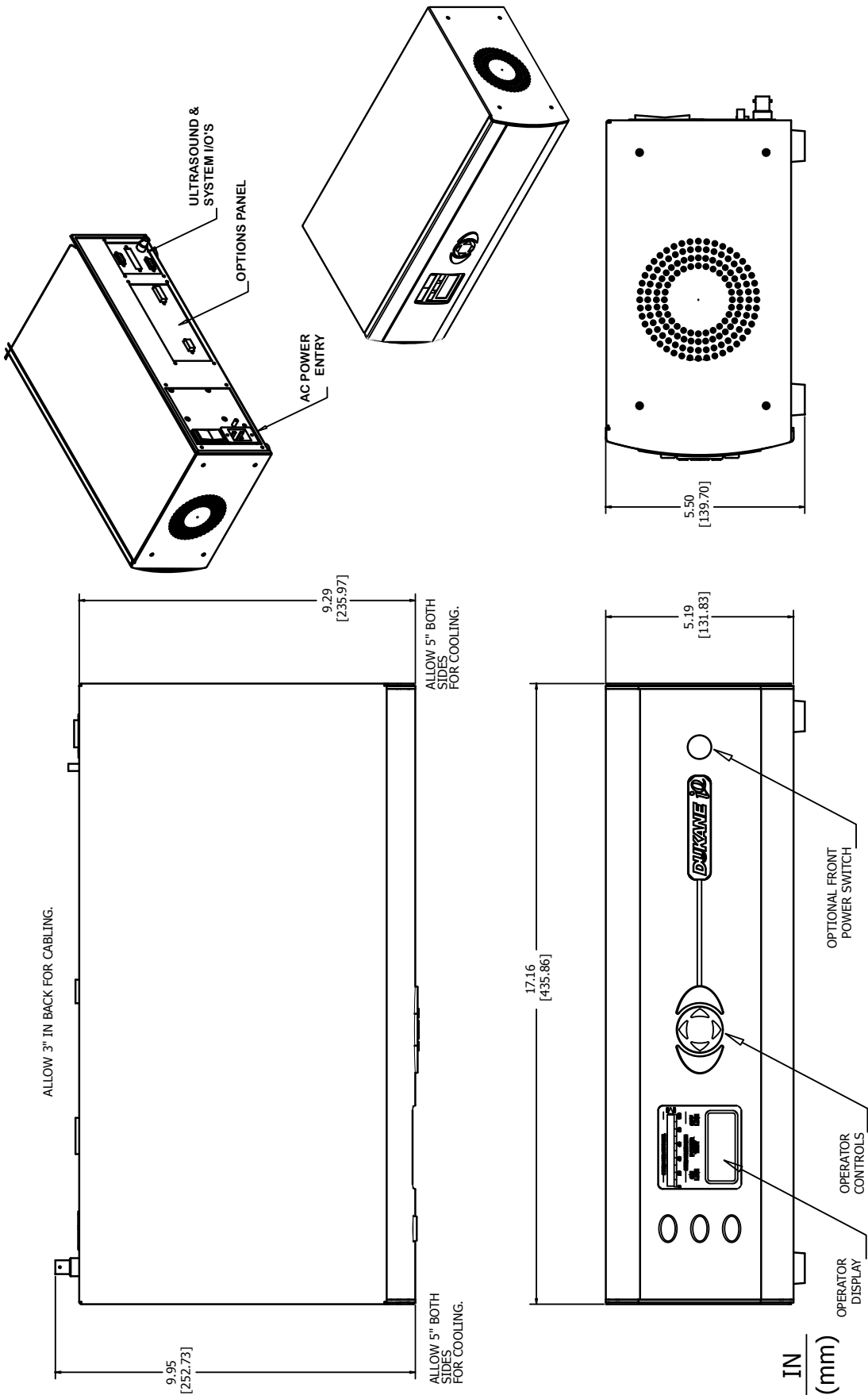

Figure 11-2 High Profile Chassis Drawing

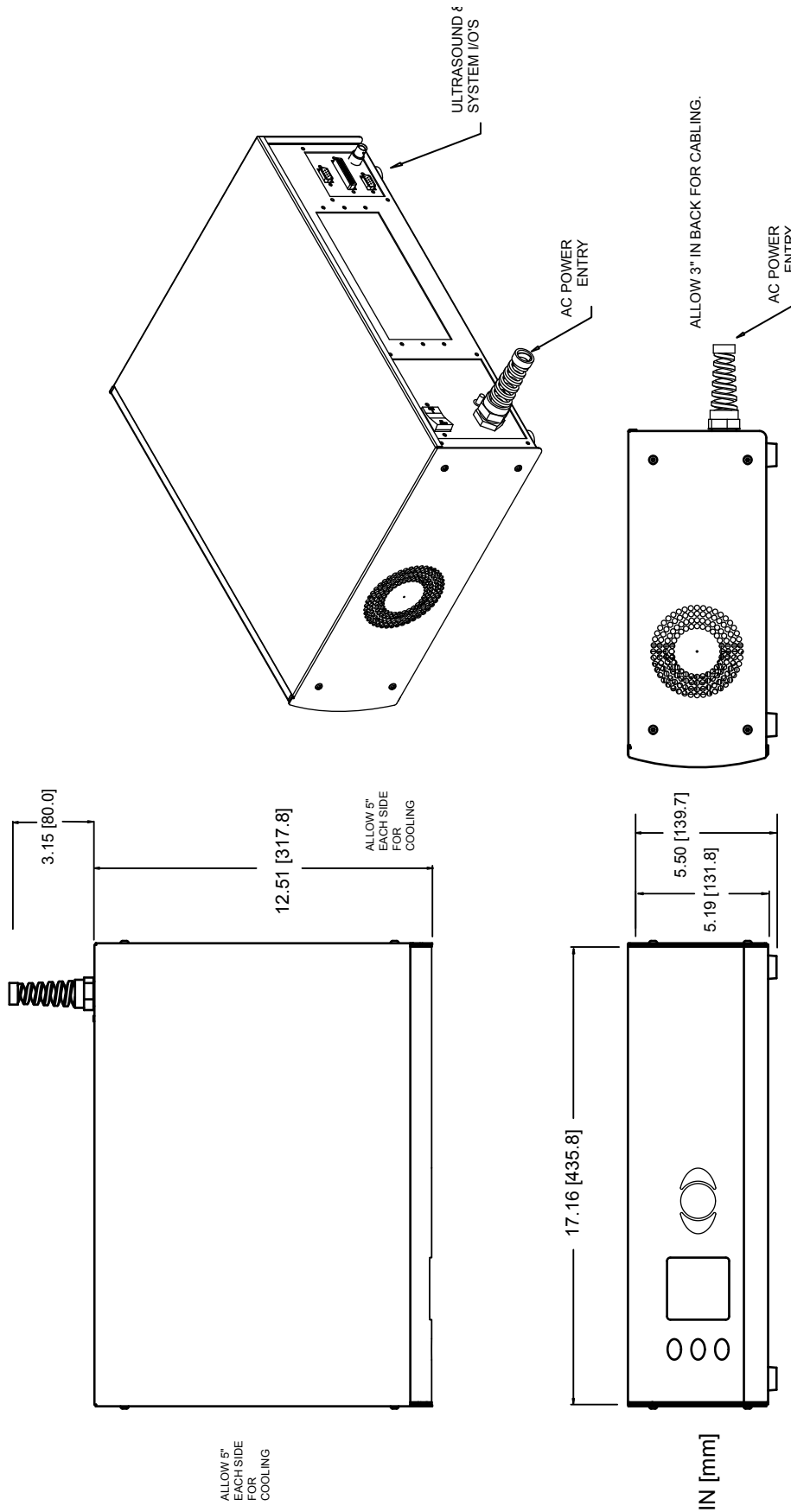

Figure 11-3 High Power (3600W) Chassis Drawing

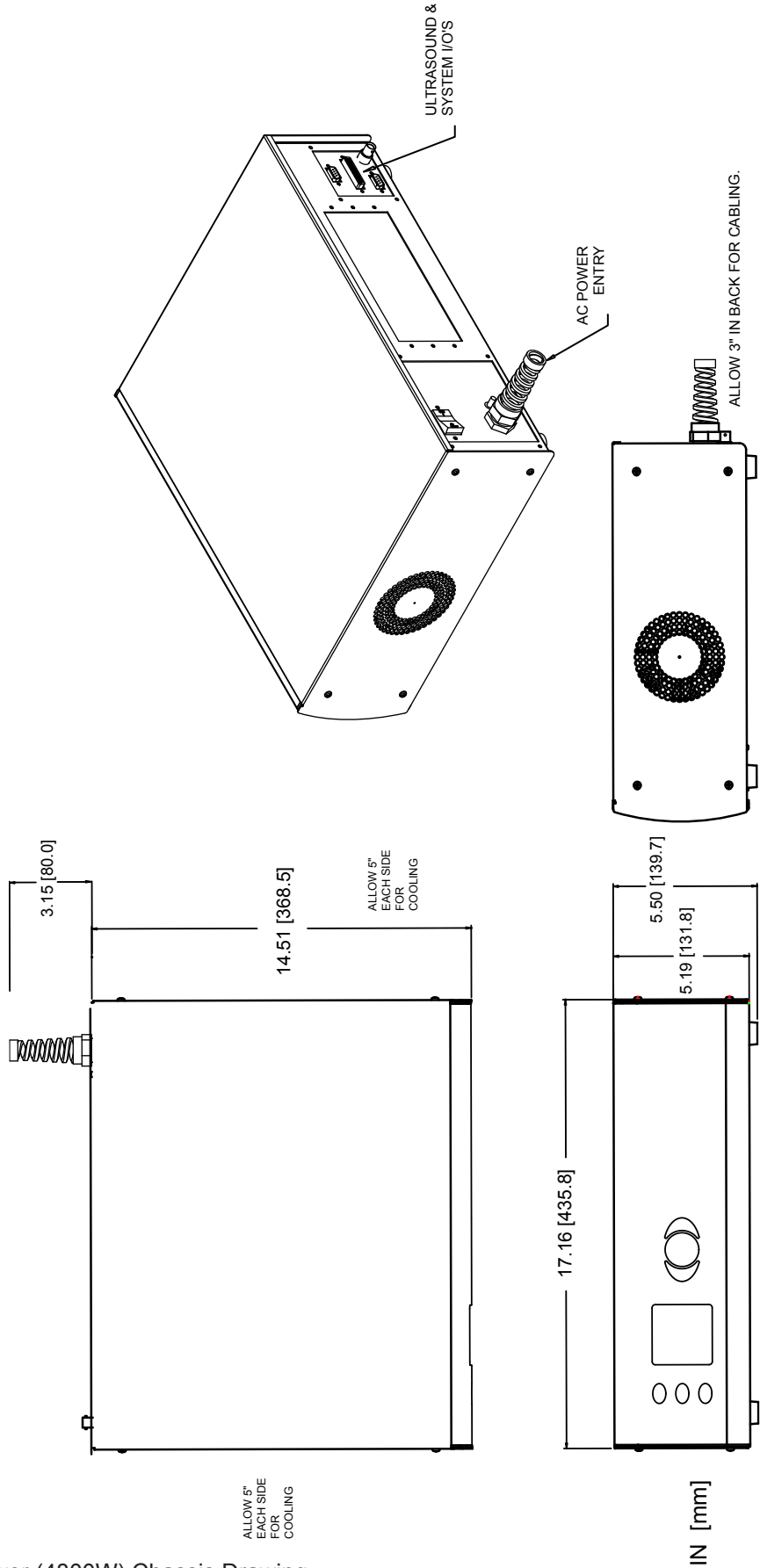

Figure 11-4 High Power (4800W) Chassis Drawing

Weight:

	High Profile		Low Profile		High Power 3600W		High Power 4800 W	
	lb	kg	lb	kg	lb	kg	lb	kg
Generator Only	25	11.3	20	9.1	32	14.5	34	15.4
Generator + Packing Materials	30	13.6	25	11.3	37	16.7	39	17.7

Table 11-I *iQ* Generator Weights

Operating Environment

Operate the generator within these guidelines:

Temperature: 40°F to 100°F (+4°C to +38°C)

Air Particulates: Keep the equipment dry
Minimize exposure to moisture, dust, dirt, smoke and mold

Humidity: 5% to 95% Non-condensing @ +5°C to +30°C

Storage guidelines (generator is not operating):

Temperature: -4°F to 158°F (-20°C to +70°C)

Air Particulates: Keep the equipment dry
Minimize exposure to moisture, dust, dirt, smoke and mold

Humidity: 5% to 95% Non-condensing @ 0°C to +30°C

AC Power Requirements

The AC input power requirements depend on the frequency and output power rating of the generator. Table 11-II below, lists both the AC requirements (maximum current drawn before overload) and the AC outlet service rating for each model.

Operating Frequency	Generator Model Number	Overload Power Ratings (Watts)	Input AC Power Requirements Nominal AC Volt @ Maximum RMS Current	North America/ Japan AC Outlet Rating
15kHz	15XX360-2X-XX	3600	200-240V 50/60 Hz @ 25 Amps	30 Amps
15kHz	15XX480-2X-XX	4800	200-240V 50/60 Hz @ 30 Amps	
20kHz	20XX120-1X-XX	1200	100-120V 50/60 Hz @ 15 Amps	15 Amps
20kHz	20XX120-2X-XX	1200	200-240V 50/60 Hz @ 8 Amps	
20kHz	20XX180-2X-XX	1800	200-240V 50/60 Hz @ 12 Amps	
20kHz	20XX240-2X-XX	2400	200-240V 50/60 Hz @ 15 Amps	
20kHz	20XX360-2X-XX	3600	200-240V 50/60 Hz @ 25 Amps	30 Amps
20kHz	20XX480-2X-XX	4800	200-240V 50/60 Hz @ 30 Amps	
30kHz	30XX090-1X-XX	900	100-120V 50/60 Hz @ 8 Amps	15 Amps
30kHz	30XX090-2X-XX	900	200-240V 50/60 Hz @ 8 Amps	
30kHz	30XX120-1X-XX	1200	100-120V 50/60 Hz @ 15 Amps	
30kHz	30XX120-2X-XX	1200	200-240V 50/60 Hz @ 8 Amps	
30kHz	30XX180-2X-XX	1800	200-240V 50/60 Hz @ 12 Amps	
40kHz	40XX060-1X-XX	600	100-120V 50/60 Hz @ 8 Amps	
40kHz	40XX060-2X-XX	600	200-240V 50/60 Hz @ 5 Amps	
40kHz	40XX090-1X-XX	900	100-120V 50/60 Hz @ 15 Amps	
40kHz	40XX090-2X-XX	900	200-240V 50/60 Hz @ 8 Amps	
40kHz	40XX120-1X-XX	1200	100-120V 50/60 Hz @ 15 Amps	
40kHz	40XX120-2X-XX	1200	200-240V 50/60 Hz @ 8 Amps	

Table 11-II AC Power Requirements

NOTES:

An X used above in the Model Numbers is a “wildcard” character meaning any valid character code combination.

Maximum line current requirement is specified at the minimum nominal AC line voltage and the rated power level.

Models rated for 200-240V nominal AC line voltage include an IEC power inlet to attach an international IEC (type) power cord. (The 3600W and 4800W models include a 30A fixed power cord.)

A power cord with a domestic three wire grounding plug is included with each standard system (NEMA 6-15P).

Models rated for 200-240V nominal AC line are fully CE compliant for use in Europe or any other country in the world.

Models rated for 200-240V nominal AC line require a 16 Amp or 30 Amp grounded AC outlet rating, outside of North America/Japan.

Models rated for 100-120V nominal AC line are for use in North America or Japan and include a 15 A fixed power cord.

The fixed power cord includes a three-wire grounding plug (NEMA 5-15P configuration). These models are fully FCC compliant, but are not usable in European countries and therefore are not CE certified.

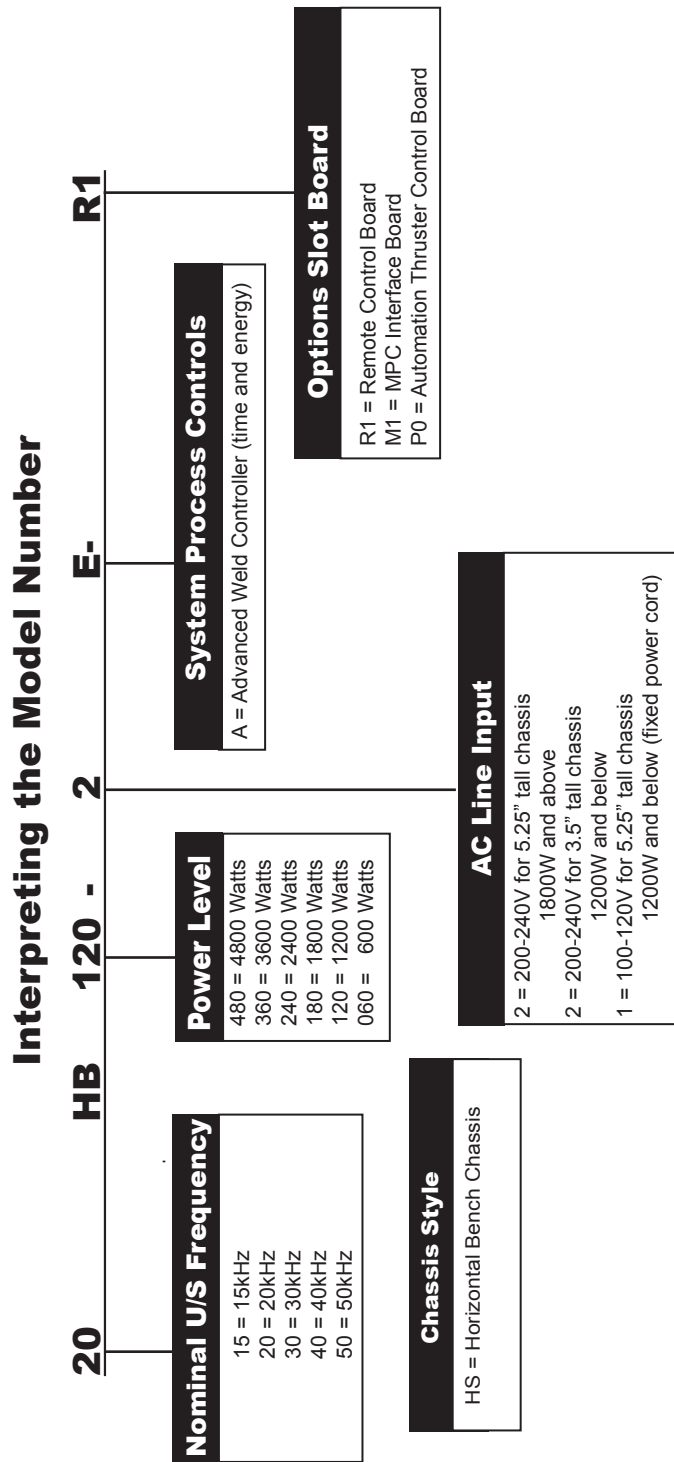

The example model number shown here is **20HB120-2E-R1**

This means:

A 20kHz generator, rated for 1,200W, horizontal bench, 3.5" tall chassis, operating on a 200-240 VAC line, designed for time and energy weld control, with a remote control board in the options slot.

Figure 11-5 Interpreting the Model Number

Regulatory Agency Compliance

FCC

The generator complies with the following Federal Communications Commission regulations.

- The limits for FCC measurement procedure MP-5, “Methods of Measurement of Radio Noise Emissions from ISM Equipment”, pursuant to FCC Title 47 Part 18 for Ultrasonic Equipment.

CE Marking

This mark on your equipment certifies that it meets the requirements of the EU (European Union) concerning interference causing equipment regulations. CE stands for Conformité Européenne (European Conformity). The equipment complies with the following CE requirements.

- The EMC Directive 2004/108/EC for Heavy Industrial —
 - EN 61000-6-4: 2001
 - EN 55011: 2003
 - EN 61000-6-2: 2001
 - EN61000-4-2
 - EN61000-4-3
 - EN61000-4-4
 - EN61000-4-5
 - EN61000-4-6
 - EN61000-4-8
 - EN61000-4-11
- The Low Voltage Directive 2006/95/EC.
- The Machinery Directive 2006/42/EC.
 - EN 60204: 2006
 - Safety of Machinery - Electrical Equipment of Machines Part 1: General Requirements.

IP (International Protection) Rating

The *iQ* generator has an IP rating from the IEC (International Electrotechnical Commission).

The rating is IP2X, in compliance with finger-safe industry standards.

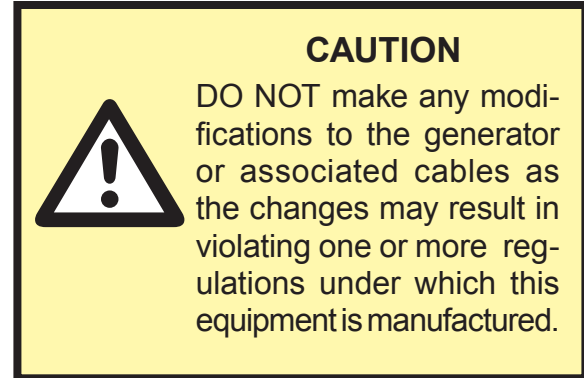

SECTION 12

Contacting Dukane

This page intentionally left blank

Contacting Dukane

Identify Equipment

When contacting Dukane about a service-related problem, be prepared to give the following information:

- Model number, line voltage and serial number
- Fault/error indicators from the LCD display
- Software version (Press **INFO**. With selection indicators at **System Information**, press **ENTER** to get this data.)
- Problem description and steps taken to resolve it

Many problems can be solved over the telephone, so it is best to call from a telephone located near the equipment.

Intelligent Assembly Solutions

Mailing Address: Dukane Ultrasonics
2900 Dukane Drive
St. Charles, IL 60174 USA

Phone: (630) 797-4900

E-Mail: ussales@dukane.com

Fax:

Main (630) 797-4949

Service & Parts (630) 584-0796

Website

The website has information about our products, processes, solutions, and technical data. Downloads are available for many kinds of literature. This is our main web address:

www.dukane.com/us/

You can locate your local representative at:

www.dukane.com/us/sales/intsales.htm

This page intentionally left blank

APPENDICES

List of Figures	109
List of Tables	110
Guide to <i>iQ</i> Generator Menu Structure	111-127

This page intentionally left blank

List of Figures

No.	Description	Page
2-1	Example of 220 Volt, Grounded, 3-prong Receptacle	8
2-2	International 220/240V Grounding	8
3-1	Lockout Device in Open Position, Unlocked	13
3-2	Bottom Lockout Device in Closed Position, Locked	13
3-3	Generator - Front View (low profile model).....	15
3-4	Rack Mounting iQ Generator.....	16
3-5	Securing iQ Generator to Benchtop	17
3-6	Generator - Rear View (low profile model)	20
4-1	Generator Rear Panel	23
4-2	IEC AC Power Inlet Connector	24
4-3	System I/O Panel	25
4-4	HD-15F for Generator Input Connector.....	26
4-5	HD-15M for Generator Input Cable Connector.....	26
4-6	DB-25F for Generator Output Connector	30
4-7	DB-25M for Generator Output Cable Connector	30
4-8	Ultrasound Output Connector.....	32
4-9	Configuration Port Connector.....	33
5-1	Front Panel Monitoring Detail.....	37
5-2	Front Panel Control Detail	38
5-3	LCD Display at Start-up 1.....	40
5-4	LCD Display at Start-up 2.....	40
5-5	LCD Display at Start-up 3.....	40
5-6	Main Menu.....	40
7-1	Rear Panel AC Breaker Switch	57
7-2	Front Panel POWER TEST LED	57
7-3	Front Panel OFFLINE LED	57
7-4	Front Panel ONLINE LED.....	57
7-5	System Test.....	58
7-6	Stop Ultrasound Output.....	59
8-1	Cable End of System I/O Connector	63
8-2	Overload Indication	64
8-3	Power Status Indicator	64
10-1	Example of 120 Volt, Grounded, 3-Prong Receptacle.....	73
10-2	120VAC Power Inlet Panel	74
10-3	HD15F for System Inputs/Outputs Connector.....	75
10-4	Option Panel and I/O Panel.....	75
10-5	Generator Rear View - Optional MPC Model	76
10-6	MPC Module Cutout Guide	78
10-7	MPC Module Rear Connectors	79

List of Figures *continued*

No.	Description	Page
10-8	MPC Module Front Connectors	79
10-9	MPC Module Status LEDs.....	80
10-10	MPC Cycle Flow Chart.....	81
10-11	Current Loop Transfer Function Graph	82
10-12	Remote Amplitude Control Module.....	82
10-13	Amplitude Control Menu Detail.....	83
10-14	Automation Thruster Control Module.....	84
10-15	DB-9 Connector with Pin Locations (J6)	84
10-16	HD-26 Connector with Pin Locations (J5)	84
10-17	NPN to PNP Conversion	86
10-18	PNP to NPN Conversion	87
10-19	+5V to +24V PNP Conversion.....	88
10-20	PROFIBUS Communications Module	90
10-21	EtherNet/IP™ Module	91
11-1	Low Profile Chassis Drawing.....	95
11-2	High Profile Chassis Drawing.....	96
11-3	High Power (3600W) Chassis Drawing	97
11-4	High Power (4800W) Chassis Drawing	98
11-5	Interpreting the Model Number.....	101

List of Tables

No.	Description	Page
2-I	iQ Generator Weights	9
3-I	Rack Mount Bracket Part Numbers	16
3-II	Standard IEC AC Power Cord Part Numbers	19
4-I	System Input Connector Signals (J2)	26
4-II	System Output Connector Signals (J3).....	31
5-I	Default Frequency Dependent Settings	42
5-II	Default Frequency Independent Settings.....	42
5-III	System Parameter Adjustment Limits	43
6-I	Ramp Up/Down Times	53
8-I	Pop-up Status Screens	66
10-1	HD15F Example of Customized System Inputs/Outputs Connector Signals.....	75
10-II	MPC I/O Connector Signals.....	77
10-III	MPC Setup Bit Inputs.....	77
10-IV	Probe Cables	79
10-V	Press Base Connector Pinout (J6).....	84
11-I	iQ Generator Weights	99
11-II	AC Power Requirements	100

Guide to iQ Generator Menu Structure

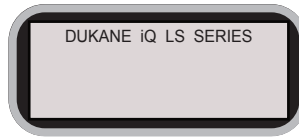

Menus	Page Number
Time Only	
Operate	113
Process Setup - Automated Probe	114
Process Setup - Hand Probe	115
Process Setup - MPC Probe	116
Process Setup - Process Limits	117
Process Setup - Utilities	118
Time and Energy	
Operate	119
Process Setup - Automated Probe	120
Process Setup - Hand Probe	121
Process Setup - MPC Probe	122
Process Setup - Process Limits	123
Process Setup - Utilities	124
Amplitude Control	125
Hardware Setup	126
Advanced Hardware Setup	127

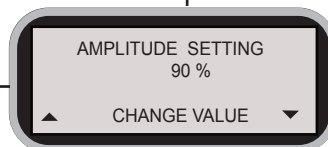
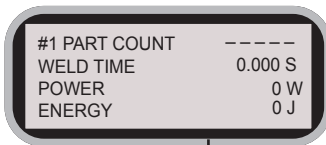
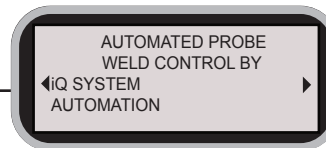
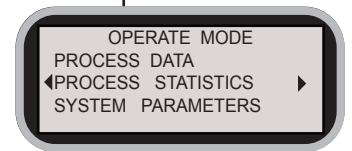

This page intentionally left blank

OPERATE Time Only Menus
Page 1 of 15

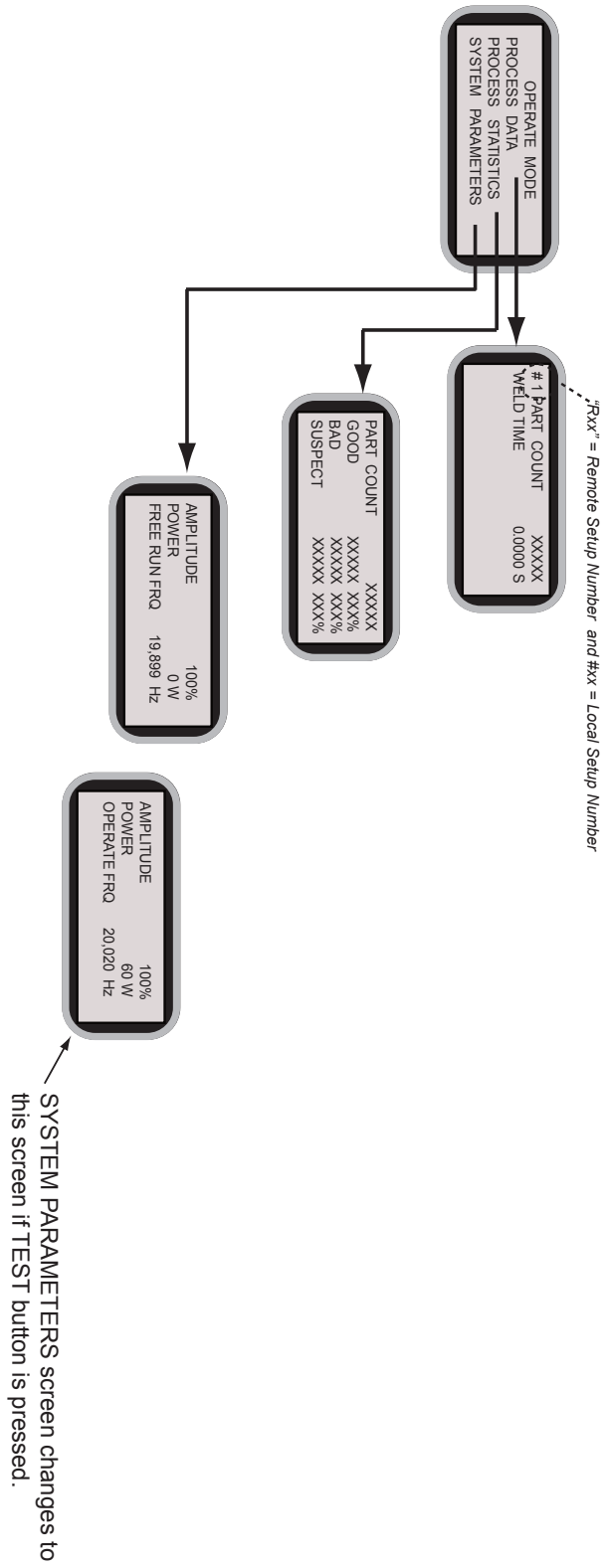

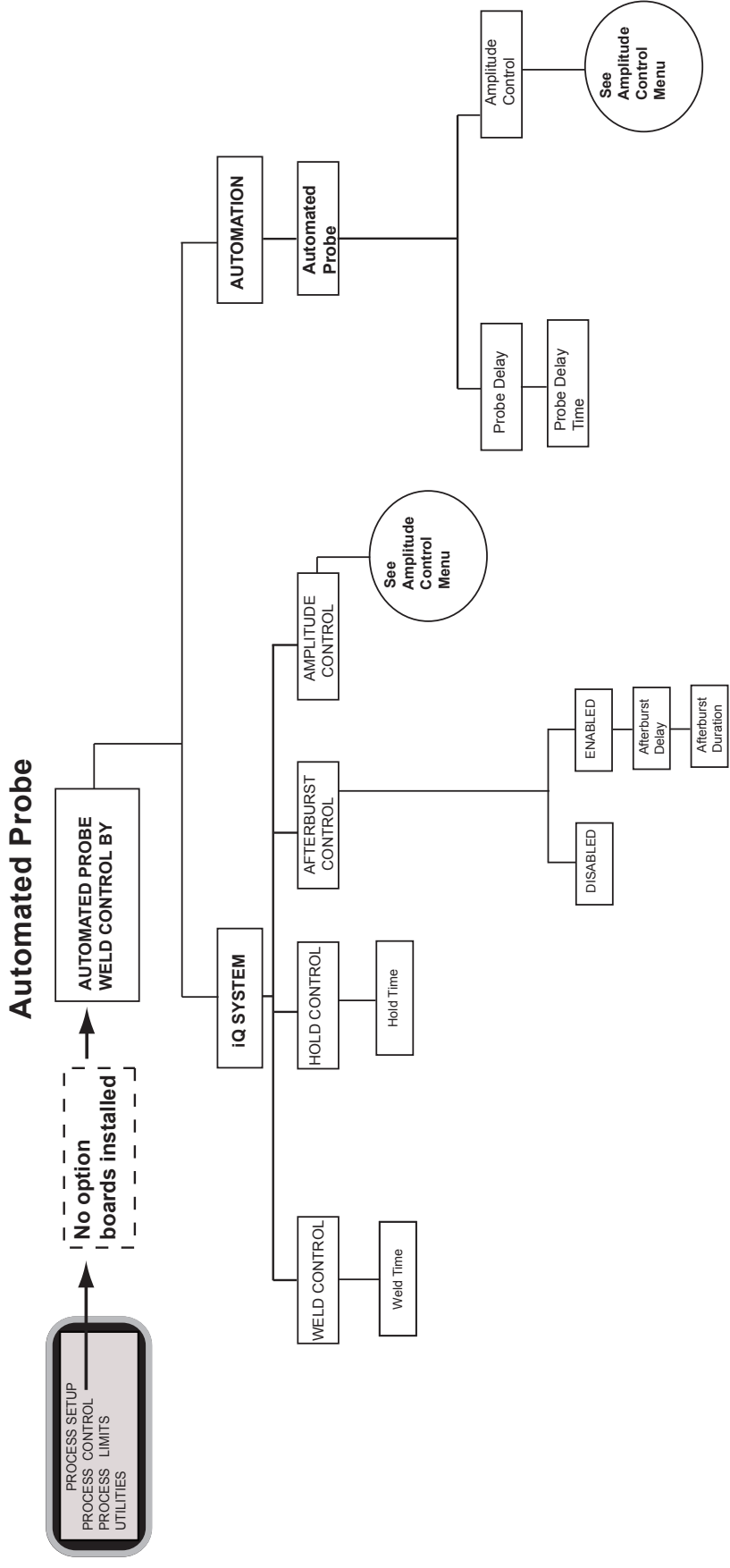

PROCESS SETUP

Time Only Menus
Page 3 of 15

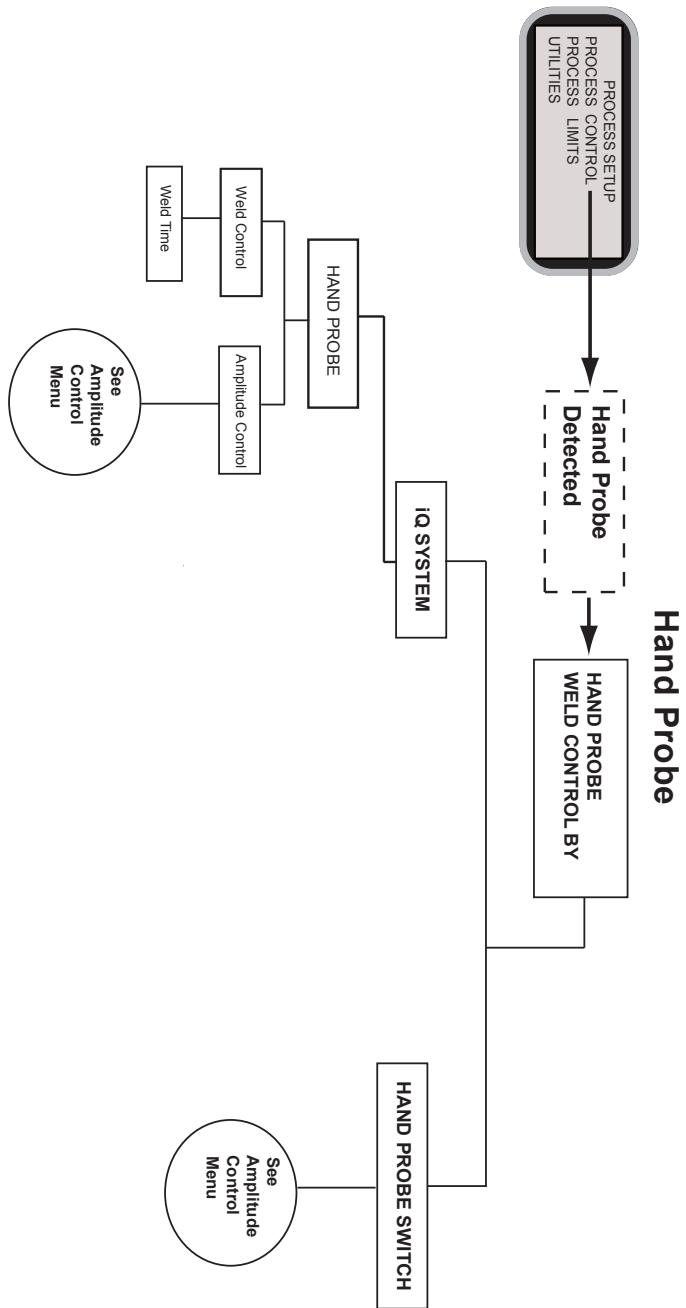

PROCESS SETUP Time Only Menus
Page 4 of 15

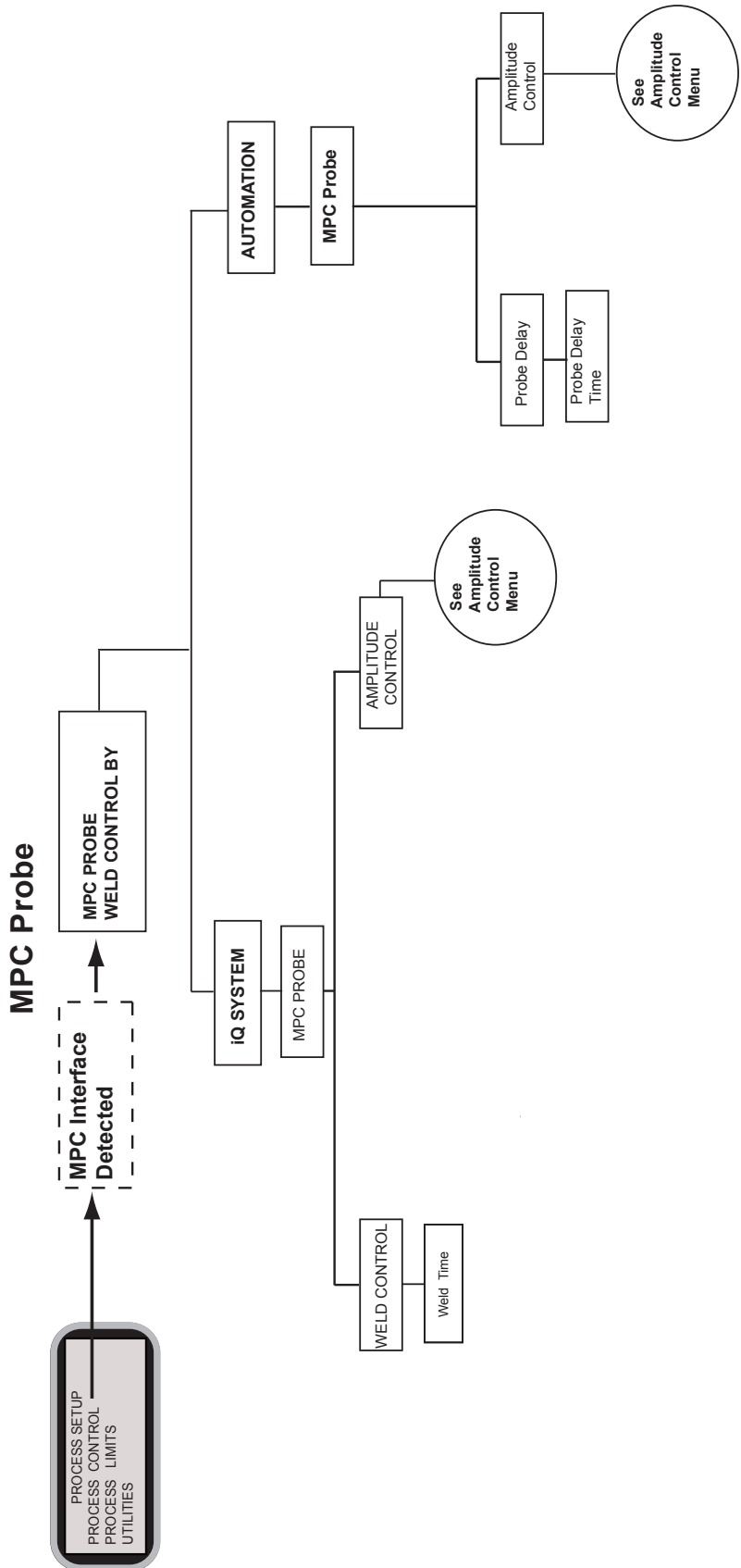

PROCESS SETUP

Time Only Menus
Page 5 of 15

Process Limits

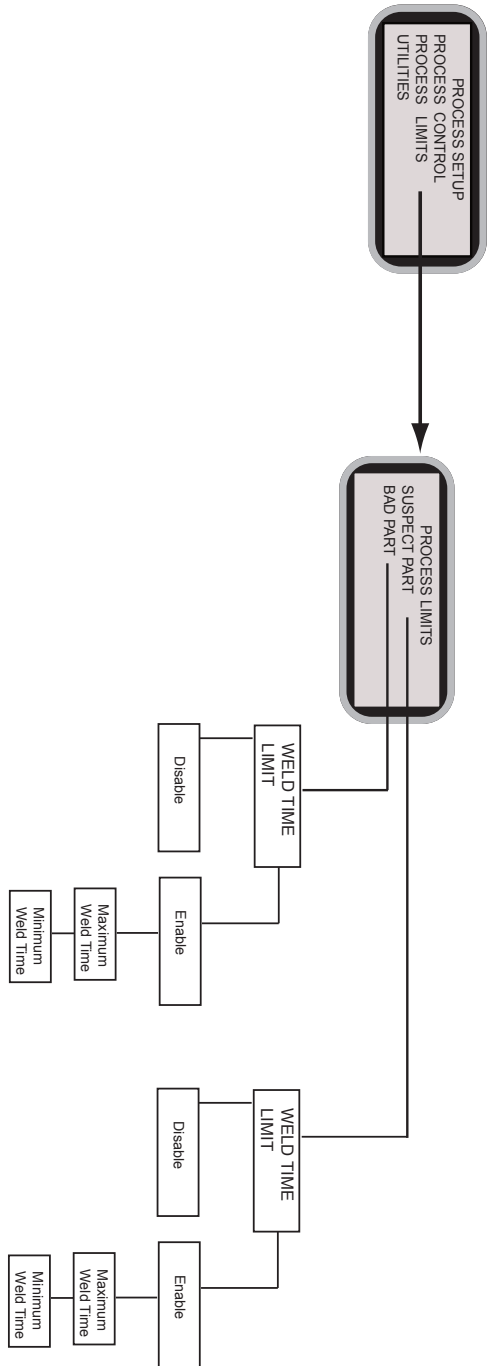

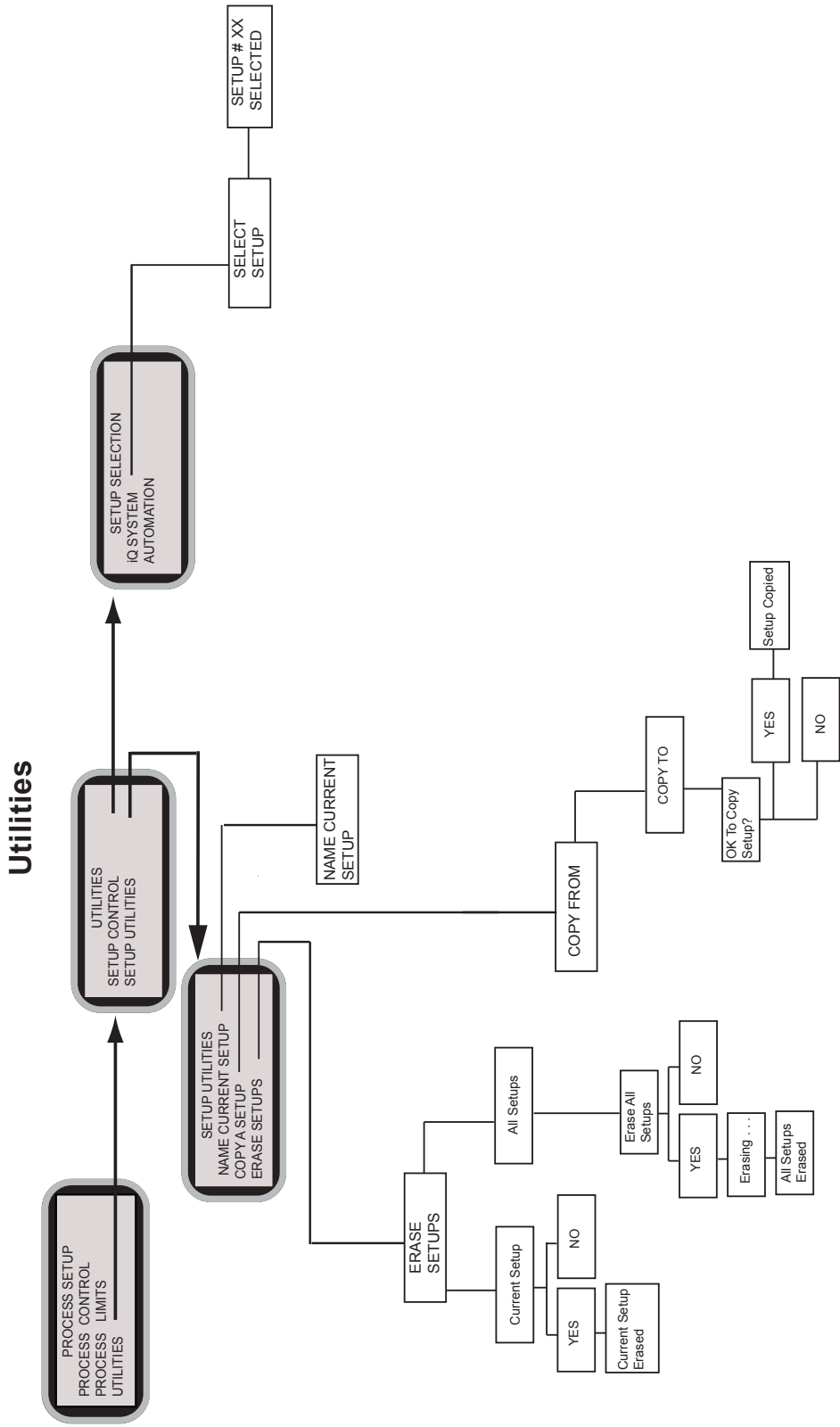

OPERATE

Time and Energy Menus

Page 7 of 15

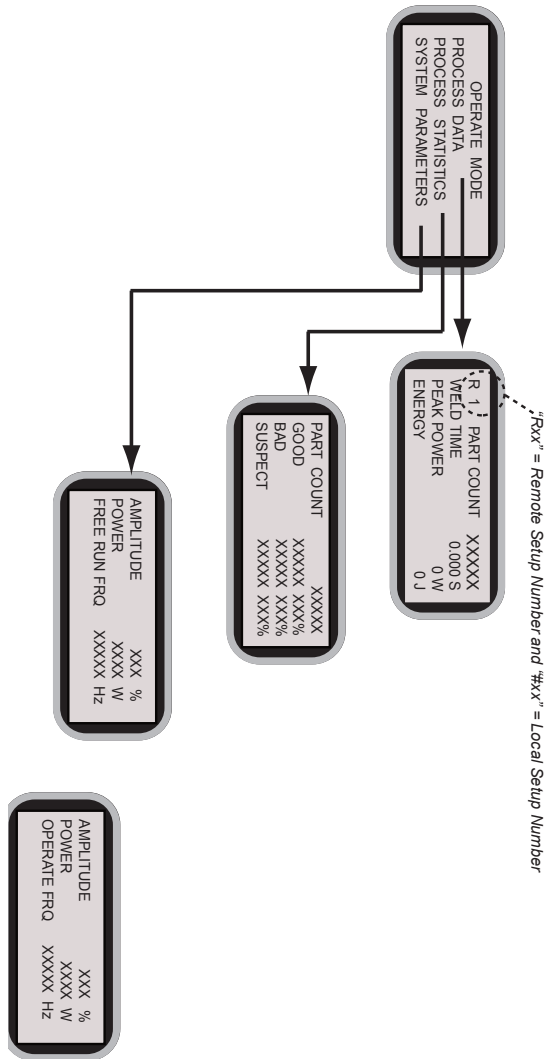

SYSTEM PARAMETERS screen changes to this screen if TEST button is pressed.

PROCESS SETUP

Time and Energy Menus
Page 8 of 15

Automated Probe

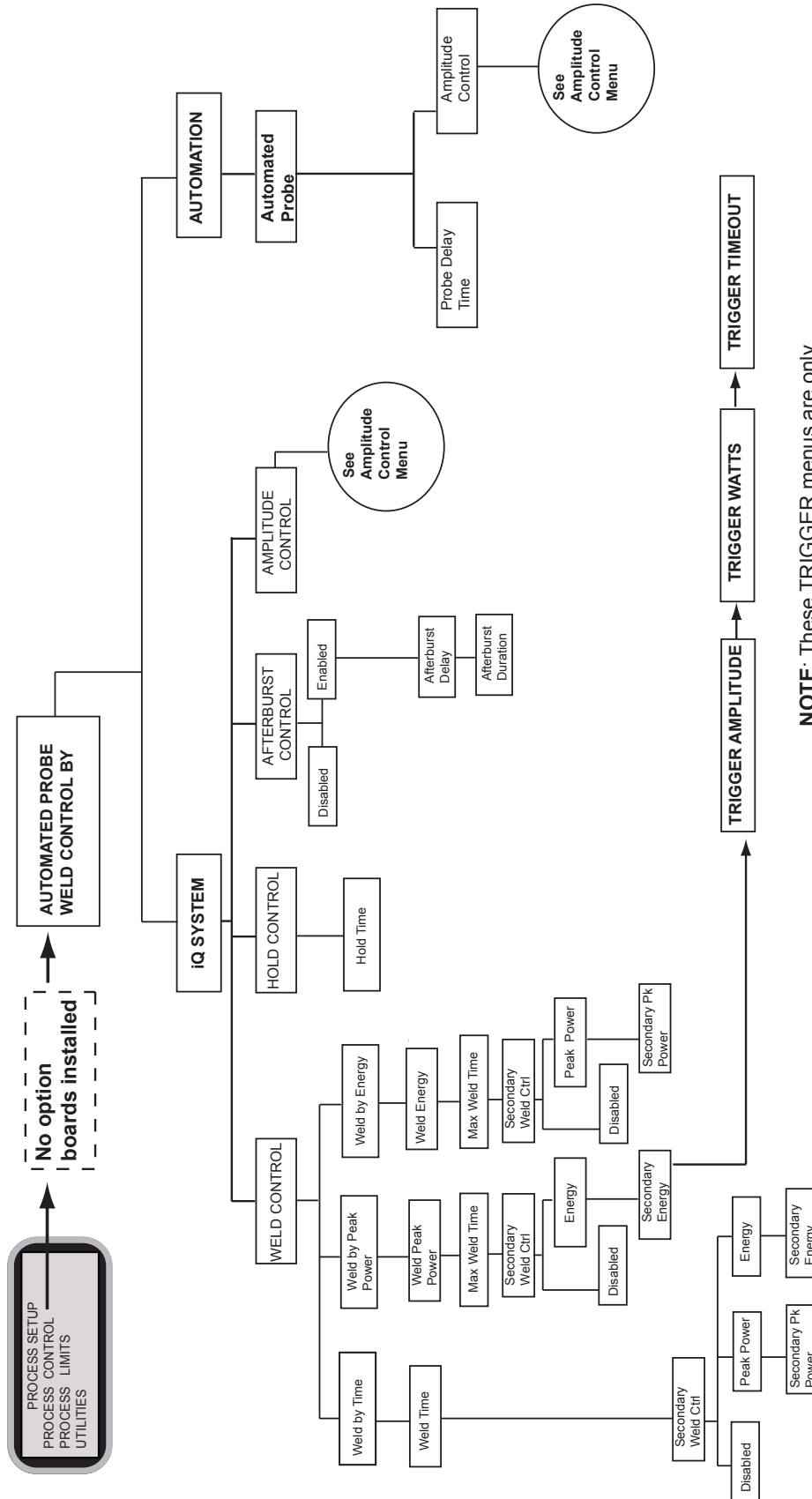

NOTE: These TRIGGER menus are only available when Trigger by Power is enabled in the Hardware Setup menu.

PROCESS SETUP

Time and Energy Menus

Page 9 of 15

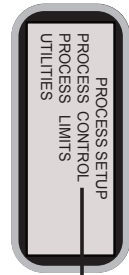

Hand Probe Detected

HAND PROBE WELD CONTROL BY

Hand Probe

NOTE: Trigger by Power is not supported in Hand Probe mode.

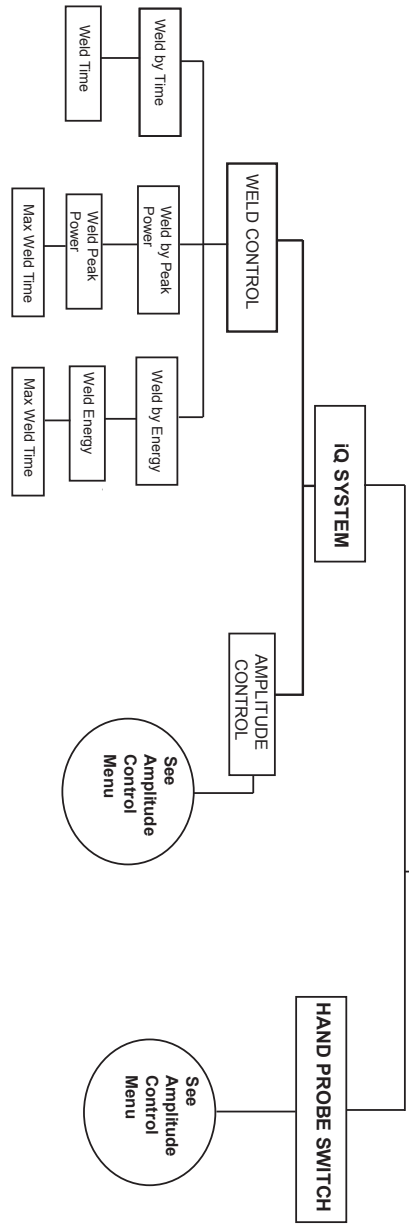

PROCESS SETUP

MPC Probe

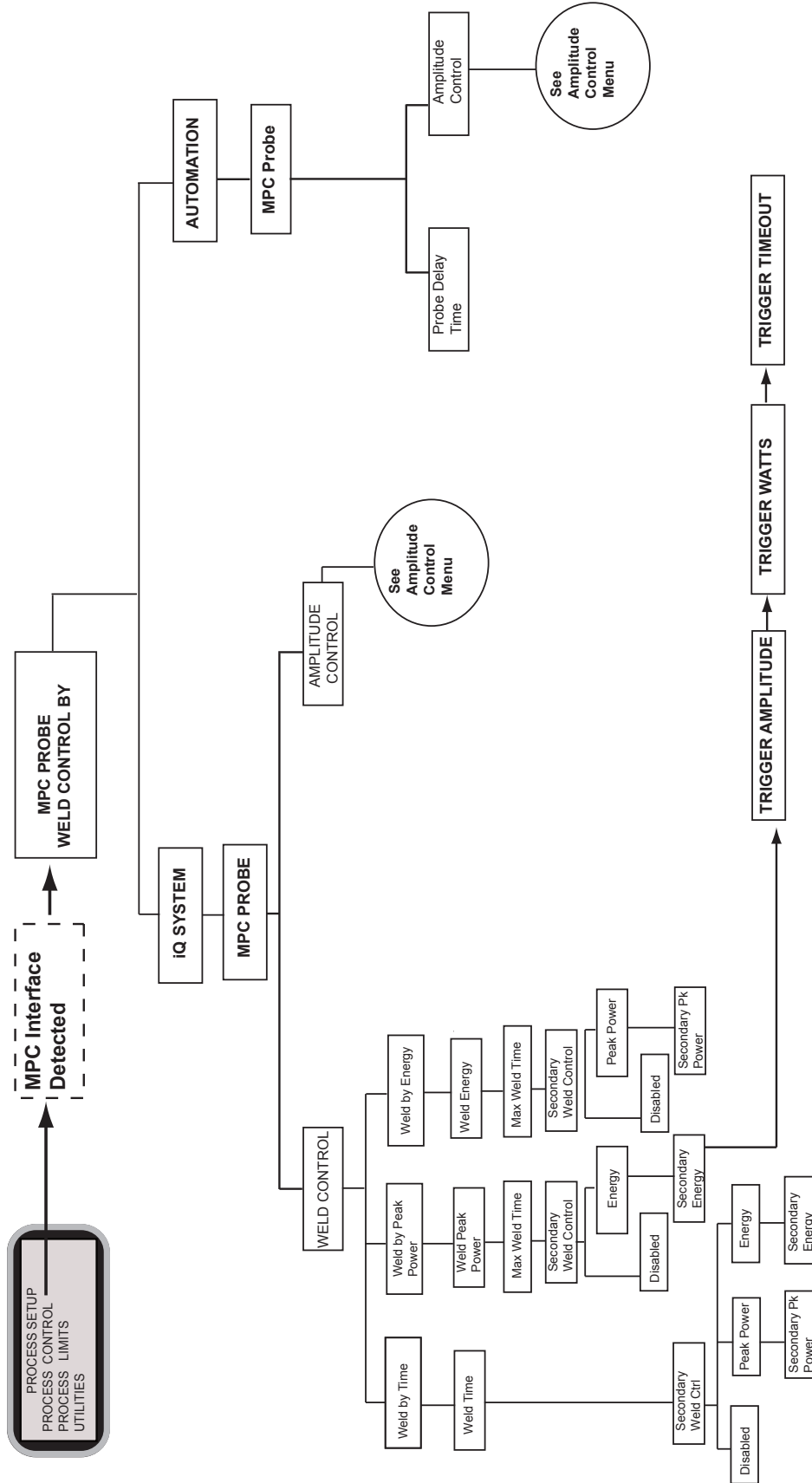

NOTE: These TRIGGER menus are only available when Trigger by Power is enabled in the Hardware Setup menu.

PROCESS SETUP

Time and Energy Menus

Page 11 of 15

Process Limits

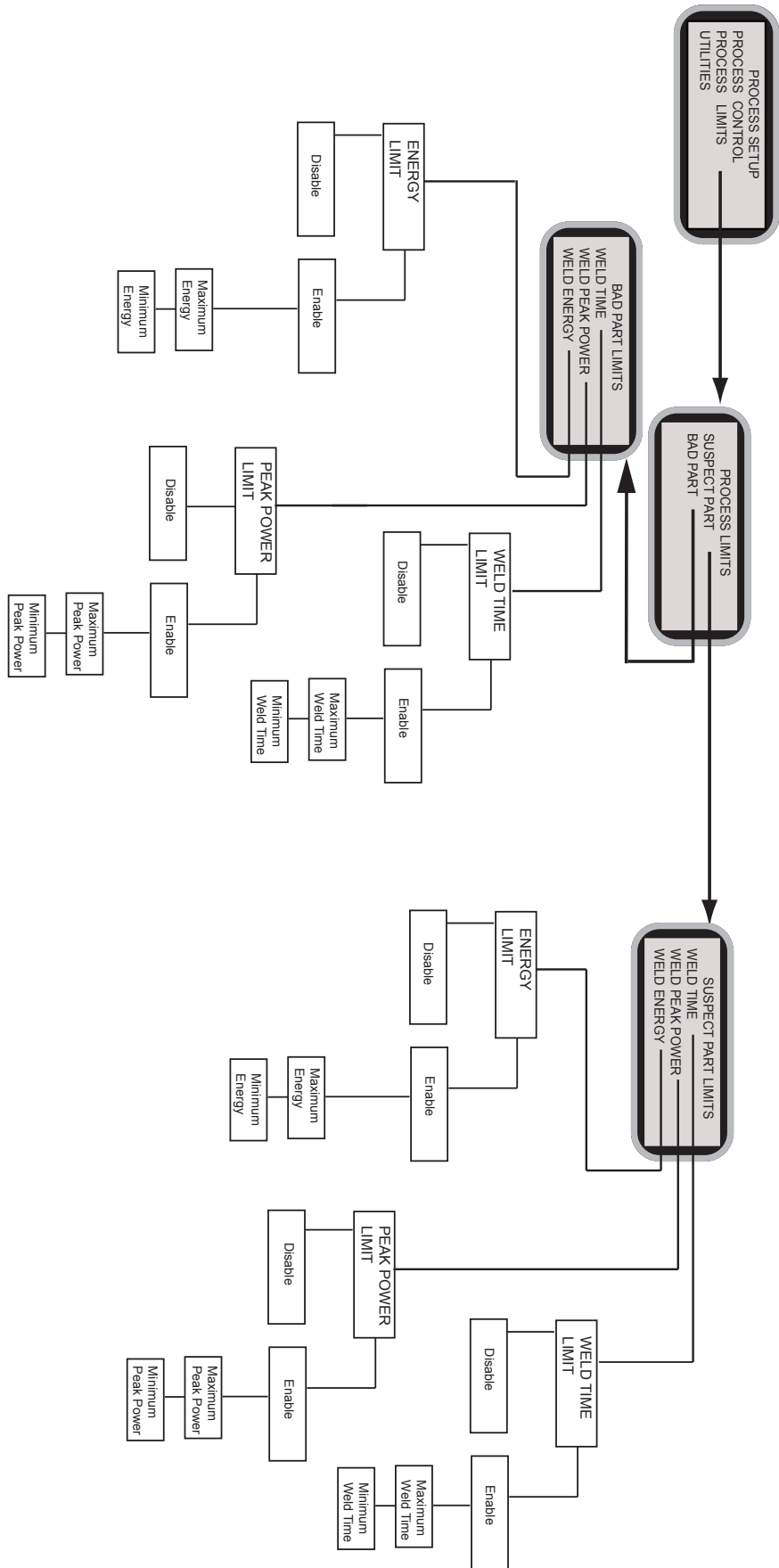

PROCESS SETUP

Utilities

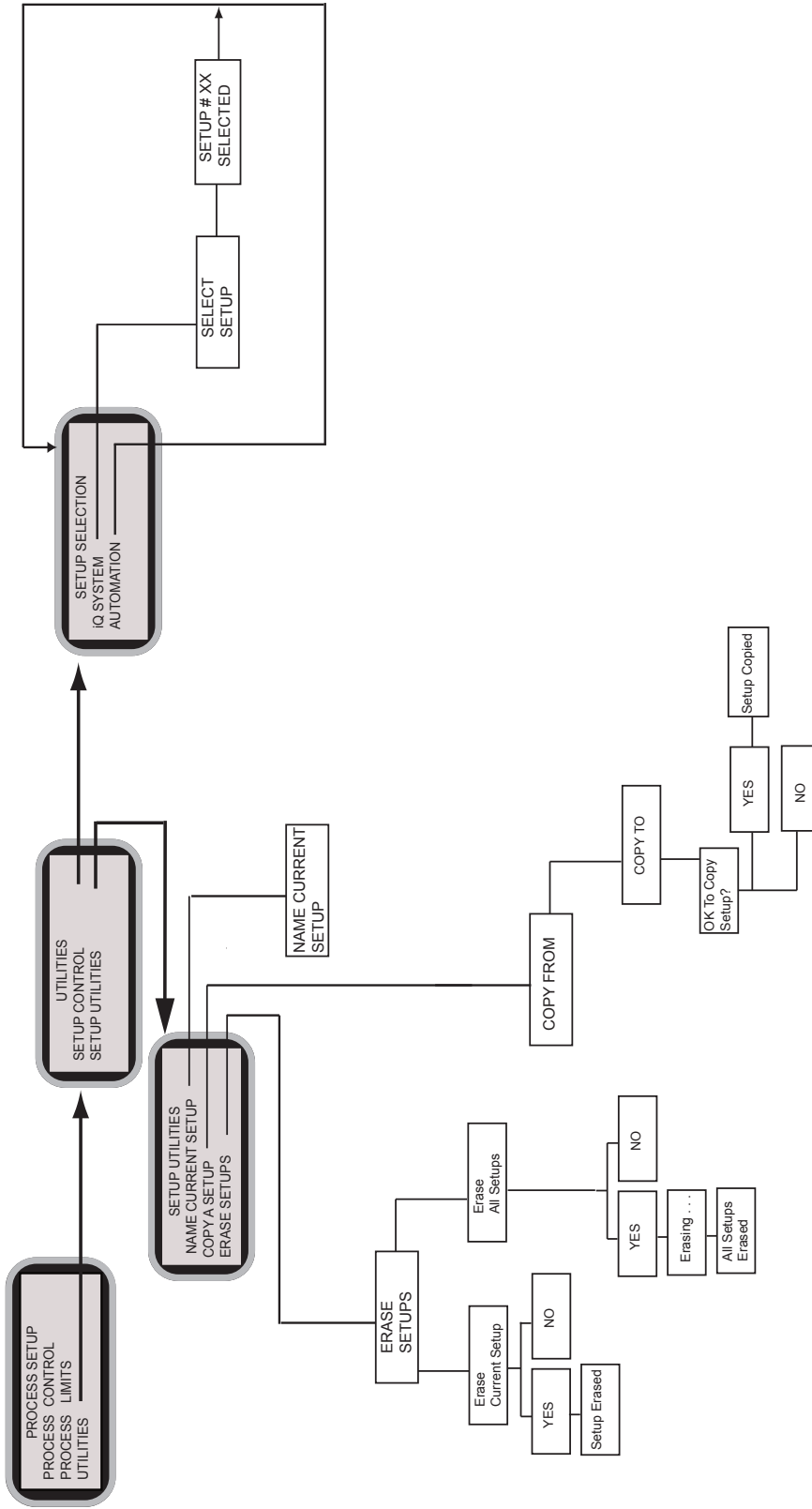

PROCESS SETUP

Time and Energy (and Time Only) Menus

Page 13 of 15

Amplitude Control

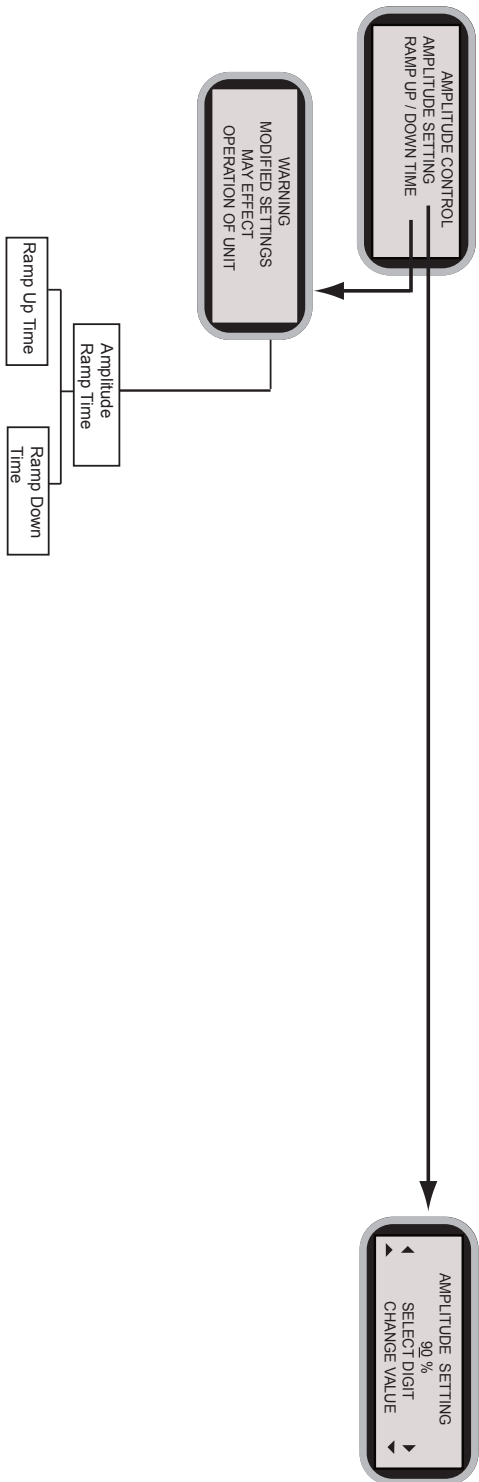

HARDWARE

*** Continued on next page

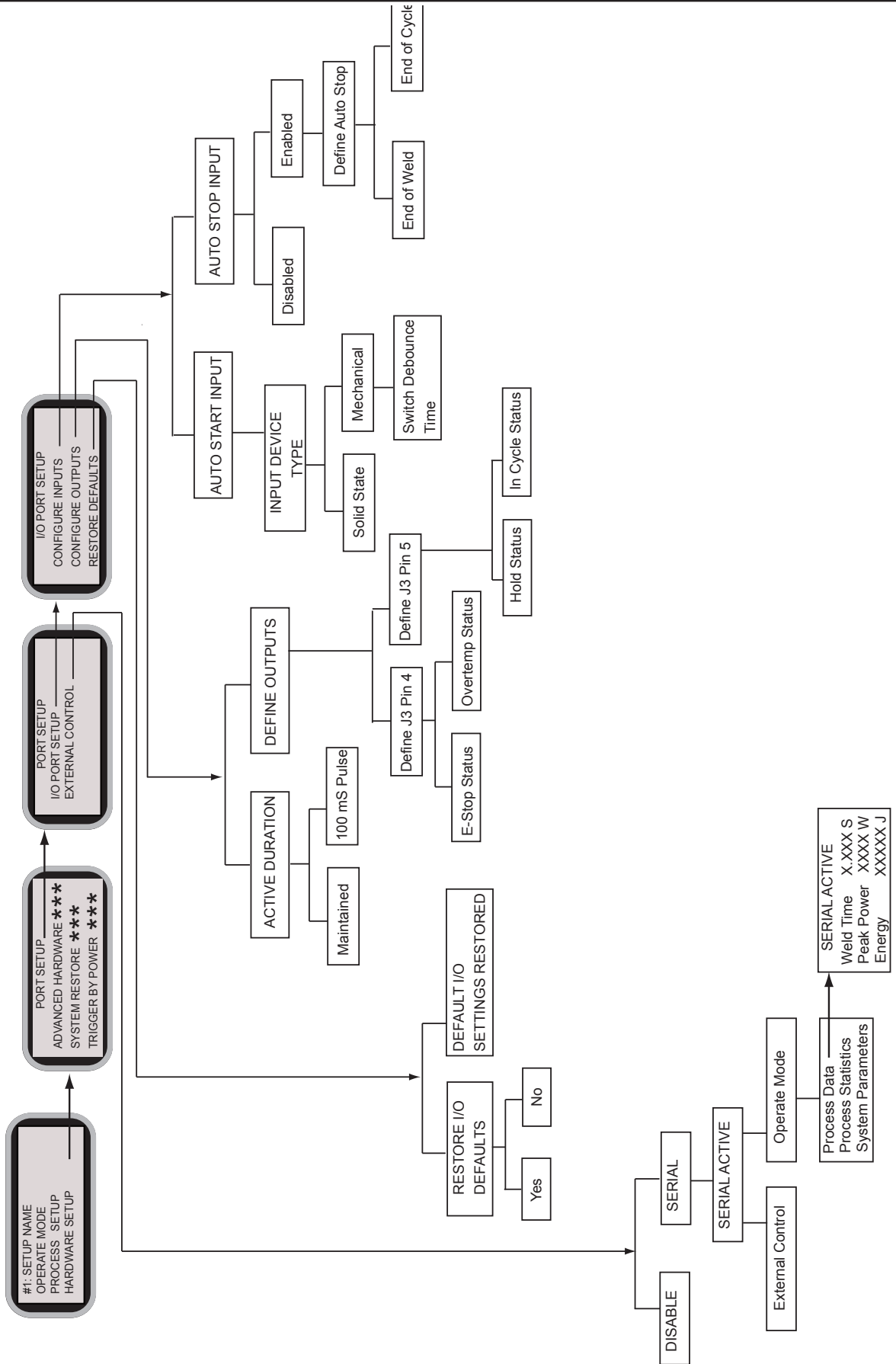

This page intentionally left blank

Dukane ISO

ISO CERTIFICATION

Dukane chose to become ISO 9001:2008 certified in order to demonstrate to our customers our continuing commitment to being a quality vendor. By passing its audit, Dukane can assure you that we have in place a well-defined and systematic approach to quality design, manufacturing, delivery and service. This certificate reinforces Dukane's status as a quality vendor of technology and products.

To achieve ISO 9001:2008 certification, you must prove to one of the quality system registrar groups that you meet three requirements:

1. Leadership
2. Involvement
3. Quality in Line Organizations and Quality System Infrastructure.

The ISO 9001:2008 standard establishes a minimum requirement for these requirements and starts transitioning the company from a traditional inspection-oriented quality system to one based on partnership for continuous improvement. This concept is key in that Dukane no longer focuses on inspection, but on individual processes.

Dukane's quality management system is based on the following three objectives:

1. Customer oriented quality. The aim is to improve customer satisfaction.
2. Quality is determined by people. The aim is to improve the internal organization and cooperation between staff members.
3. Quality is a continuous improvement. The aim is to continuously improve the internal organization and the competitive position.



Please refer to our website at:
www.dukane.com/us/sales/intsales.htm
to locate your local representative.

iQ Series, LS Generators, User's Manual

Part No. 403-574-01



www.dukane.com/us

Printed in the United States of America

Dukane Intelligent Assembly Solutions • 2900 Dukane Drive • St. Charles, Illinois 60174 USA • TEL (630) 797-4900 • FAX (630) 797-4949

Free Manuals Download Website

<http://myh66.com>

<http://usermanuals.us>

<http://www.somanuals.com>

<http://www.4manuals.cc>

<http://www.manual-lib.com>

<http://www.404manual.com>

<http://www.luxmanual.com>

<http://aubethermostatmanual.com>

Golf course search by state

<http://golfingnear.com>

Email search by domain

<http://emailbydomain.com>

Auto manuals search

<http://auto.somanuals.com>

TV manuals search

<http://tv.somanuals.com>