

ASSEMBLY INSTRUCTIONS

DX-WD1239

TV Cart

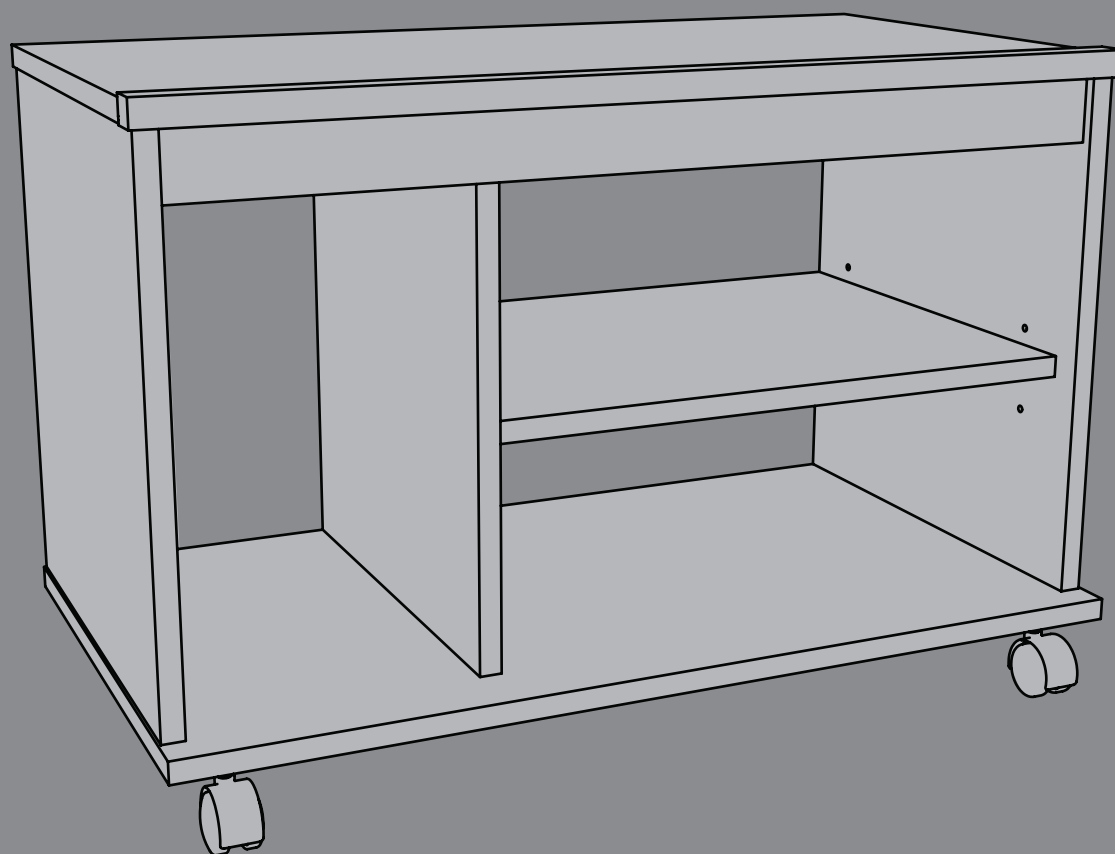

Safety information and specifications	2
Tools needed	3
Package contents	3
Assembly instructions.....	5

Safety information and specifications



CAUTION:

This TV cart's work surface is intended only for use with a product not weighing more than 95 lbs. (43.09 kg) and having 42" wide flat-panel TV dimensions that will permit it to sit evenly on your TV cart. Using with other products, including products that weigh more than the maximum weight allowed, may result in instability, which may cause possible injury.

Maximum weight: 95 lbs. (43.09 kg)
 Maximum screen size: 42"
 Weight capacity (top of TV cart): 95 lbs. (43 kg)
 Weight capacity (middle shelf): 25 lbs. (11 kg)
 Weight capacity (lower shelf): 30 lbs (13 kg)
 Overall dimensions: W x H x D
 28.12 x 18.75 x 14.88 inches (71.45 x 47.6 x 37.8 cm)
 Top of TV cart: W x D
 28.12 x 14.88 inches (71.45 x 37.8 cm)
 Usable upper shelf (shelf in middle position) :W x H x D
 17.81 x 6.31 x 13.56 inches (45.2 x 16 x 34.3 cm)
 Usable lower shelf (shelf in middle position): W x H x D
 17.81 x 6.38 x 15.5 inches (45.2 x 16.2 x 39.4 cm)

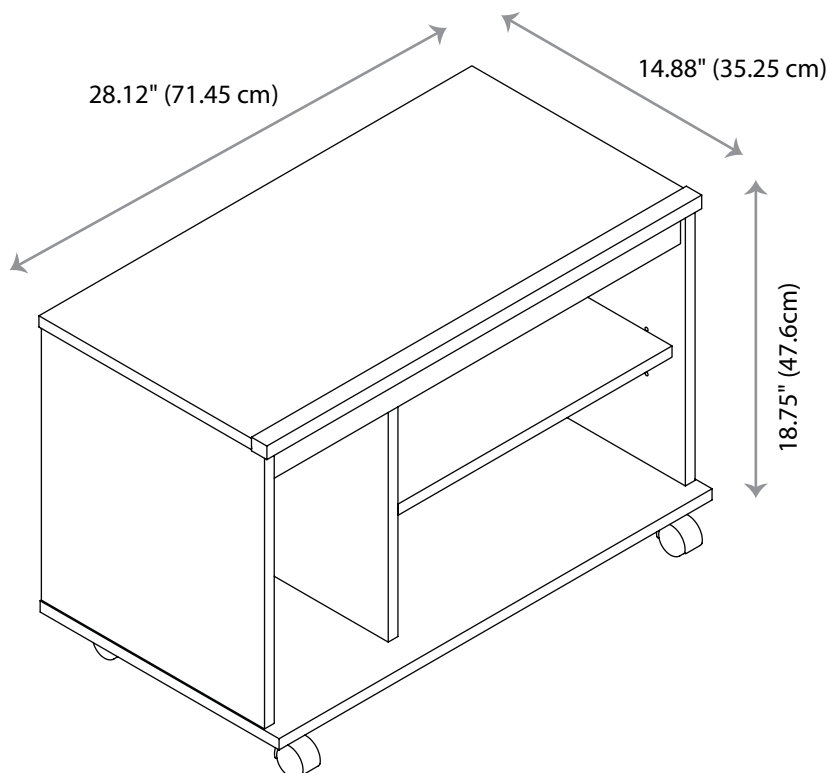

Warnings

- Do not let children climb on your TV cart or play near it. Your TV cart may tip over causing the TV or cart to injure someone.
- When placing items on the shelves or the top of the TV cart, load the bottom shelf first and work up to the top of your TV cart.
- Do not overload the shelves. They may break.
- Do not move your TV cart with items on the top or shelves. Your TV cart may tip over and injure someone. Before you move your TV cart, unload starting with the top of your TV cart and working to the bottom shelf.

Need help? Call 800-305-2204

Tools needed

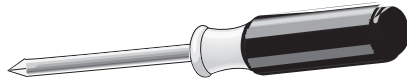

No. 2 Phillips screwdriver

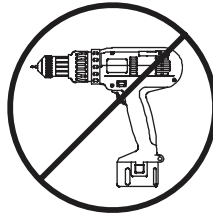

Caution: Do not use an electric drill or screwdriver

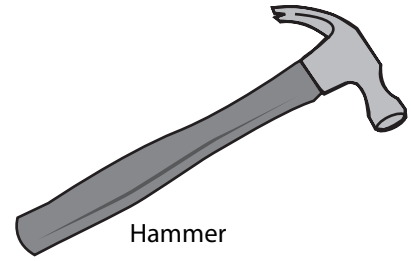



Hammer

Package contents: hardware

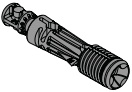
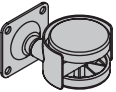
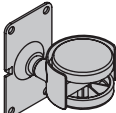
Make sure you have all the hardware necessary to assemble your new TV cart:

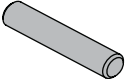
Label	Hardware	Qty.
I2	 Hidden cam	9
J2	 Cam dowel	9
K	 Swivel caster	2
L	 Non-swivel caster	2

Label	Hardware	Qty.
M	 Metal pin	8
N	 Rubber sleeve	4
O	 Warning label	1

Using a screw that is too long will cause damage your TV cart. Before beginning assembly, separate each type of screw. Carefully study the screw table below. You can use the ruler at the bottom of the screw table to measure screws. Pay close attention to the color of each screw.

You may receive extra hardware with your TV cart.

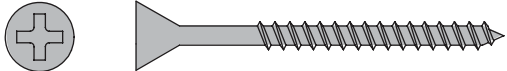
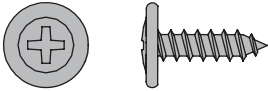
Letter	Description	Qty.	Letter	Description	Qty.
P	 Black 1 7/8" (47.75 mm) flat head screw	6	Q	 Black 9/16" (14.22 mm) large head screw	16

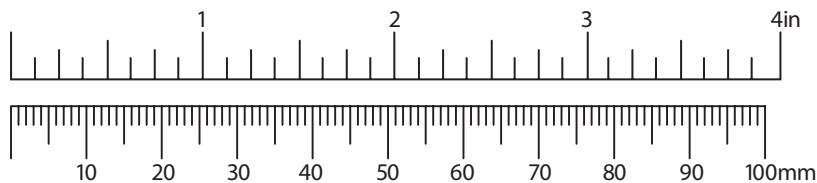

Need help? Call 800-305-2204

Package contents: parts

Note: All parts except for the stop molding (**H**) have a lettered sticker to make identifying parts easier.

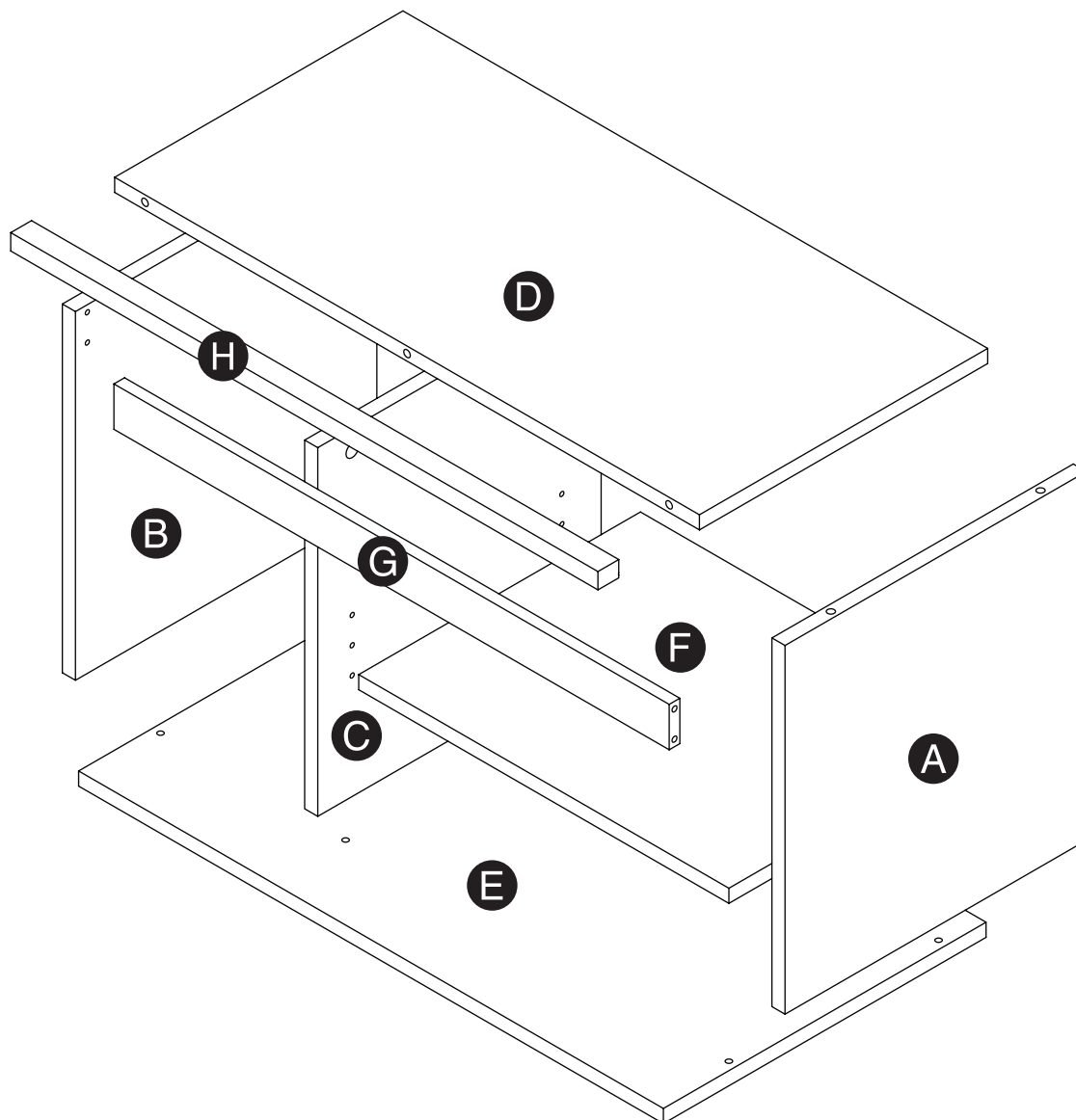

Letter	Description	Qty.	Letter	Description	Qty.
A	Right end	1	E	Bottom	1
B	Left end	1	F	Adjustable shelf	1
C	Upright	1	G	Valance	1
D	Top	1	H	Stop molding	1

Need help? Call 800-305-2204

Step 1:

Assemble your TV cart on a carpeted floor or on the empty carton to avoid scratching your TV cart or the floor.

Push nine hidden cams (**I2**) into the ends (**A** and **B**), upright (**C**), and top (**D**), then insert the metal end of a cam dowel (**J2**) into each hidden cam.

Do not tighten the hidden cams in this step.

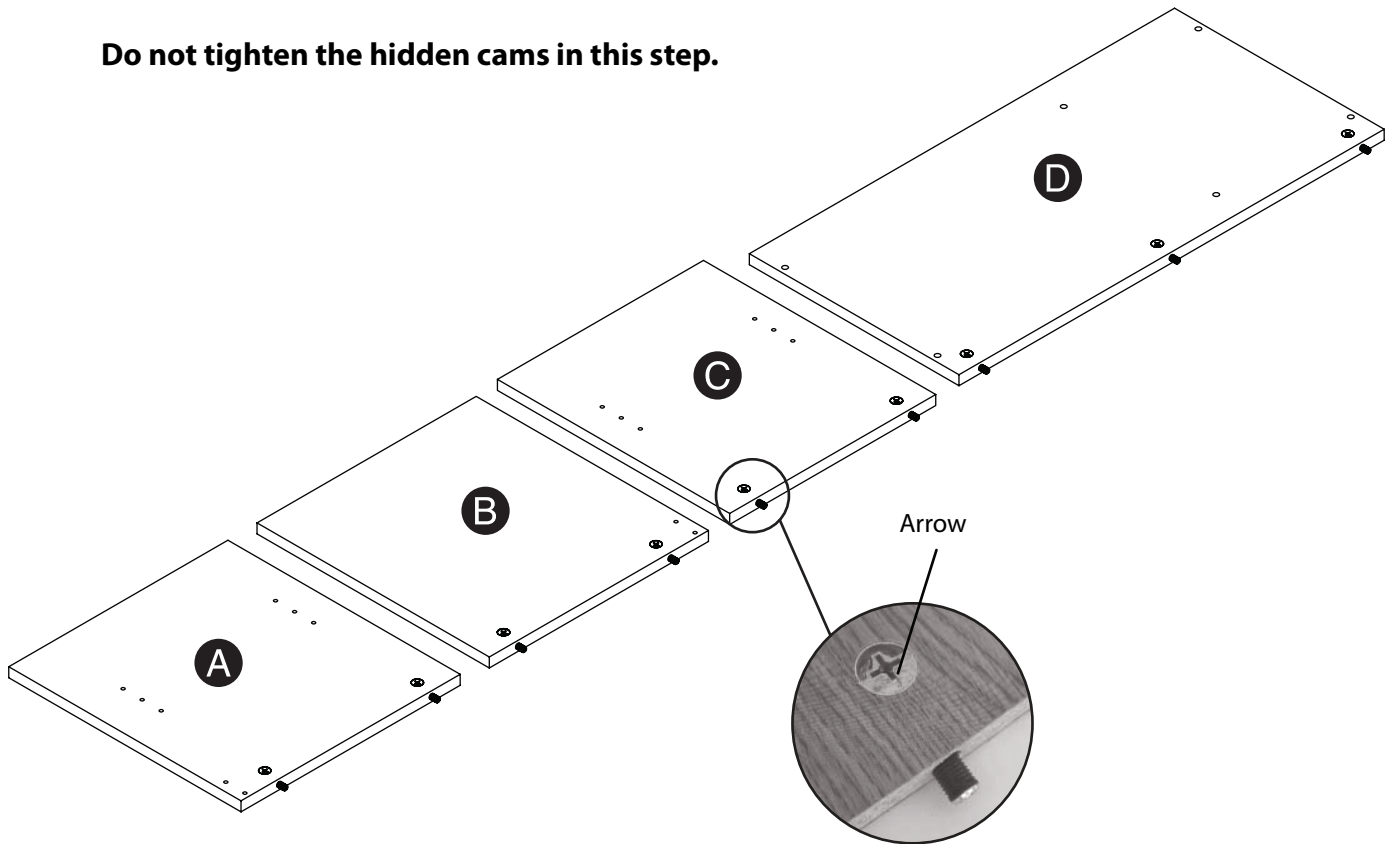
**You'll need:**

I2 (9)

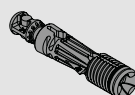

J2 (9)

Need help? Call 800-305-2204

Step 2:

Insert two metal pins (**M**) into the two holes beside the hidden cam on the right end (**A**). Repeat this step for the left end (**B**).

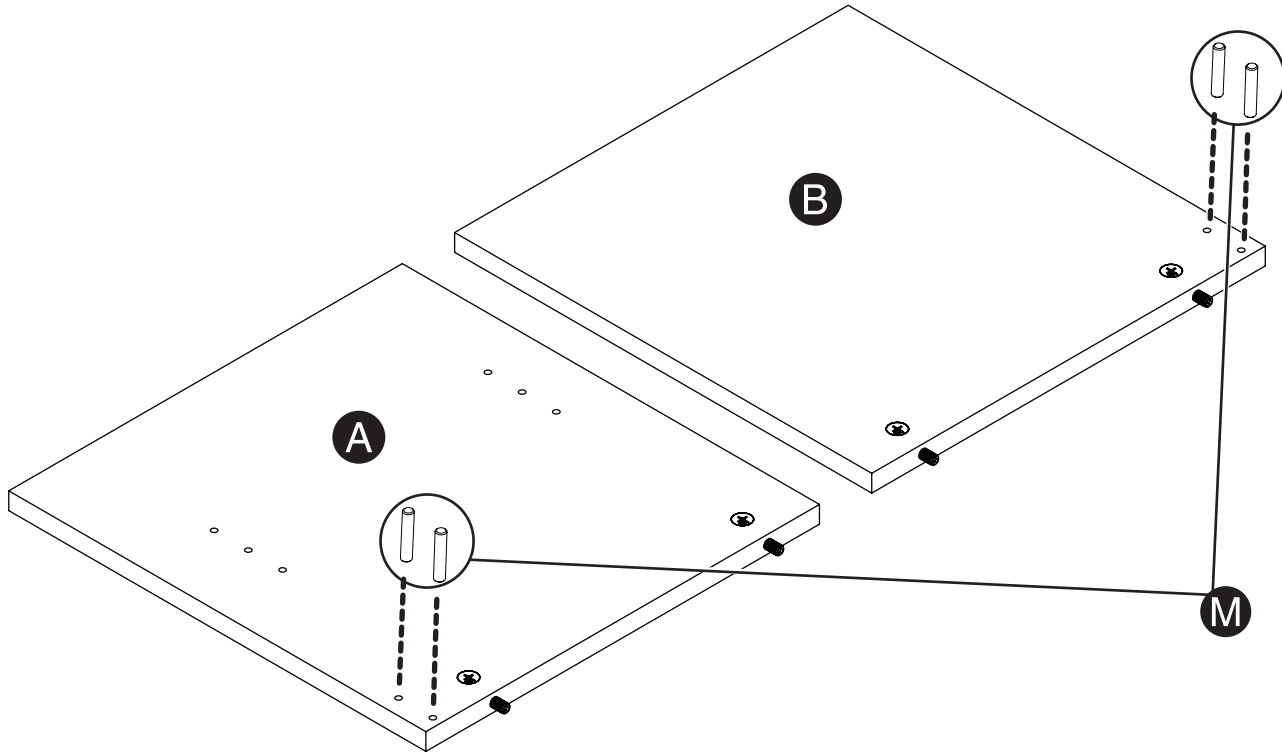
**You'll need:****M** (4)

Need help? Call 800-305-2204

Tightening hidden cams

In the **remaining** steps, use these illustrations for instructions on tightening hidden cams.

Warning: Risk of damage or injury. Hidden cams must be completely tightened. Hidden cams that are not completely tightened will loosen, and parts may separate.

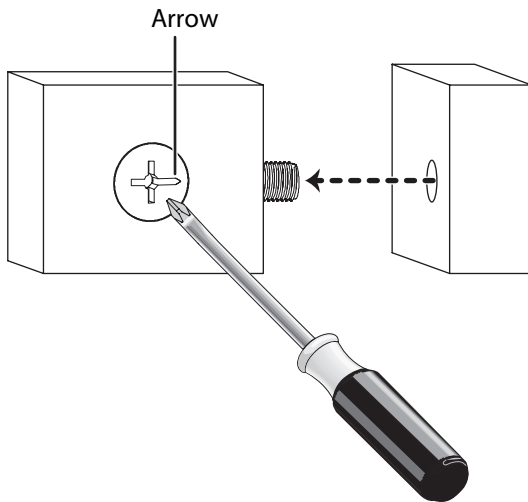

In the illustration below, the hidden cam has not been tightened enough.

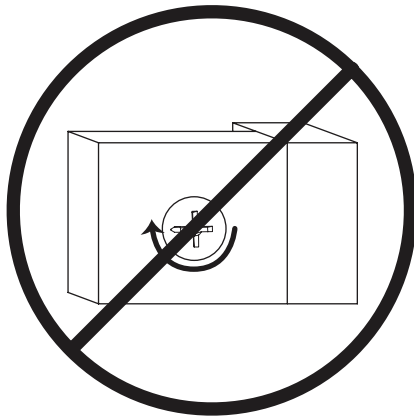

Make sure that you turn the hidden cam a minimum of 190° to a maximum of 210°. Note the position of the arrow on the hidden cam.

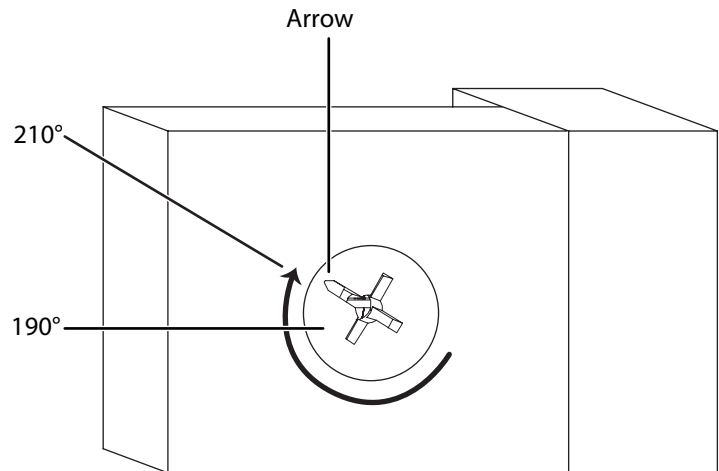

You'll need:

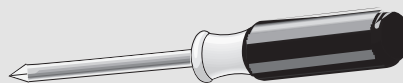

Phillips screwdriver

Need help? Call 800-305-2204

Step 3:

Fasten the stop molding (**H**) to the top (**D**). Use a Phillips screwdriver to tighten three hidden cams. See "Tightening hidden cams" on page 7.

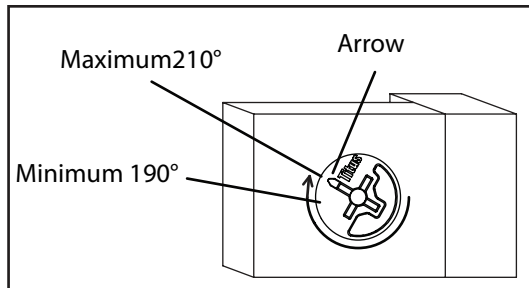
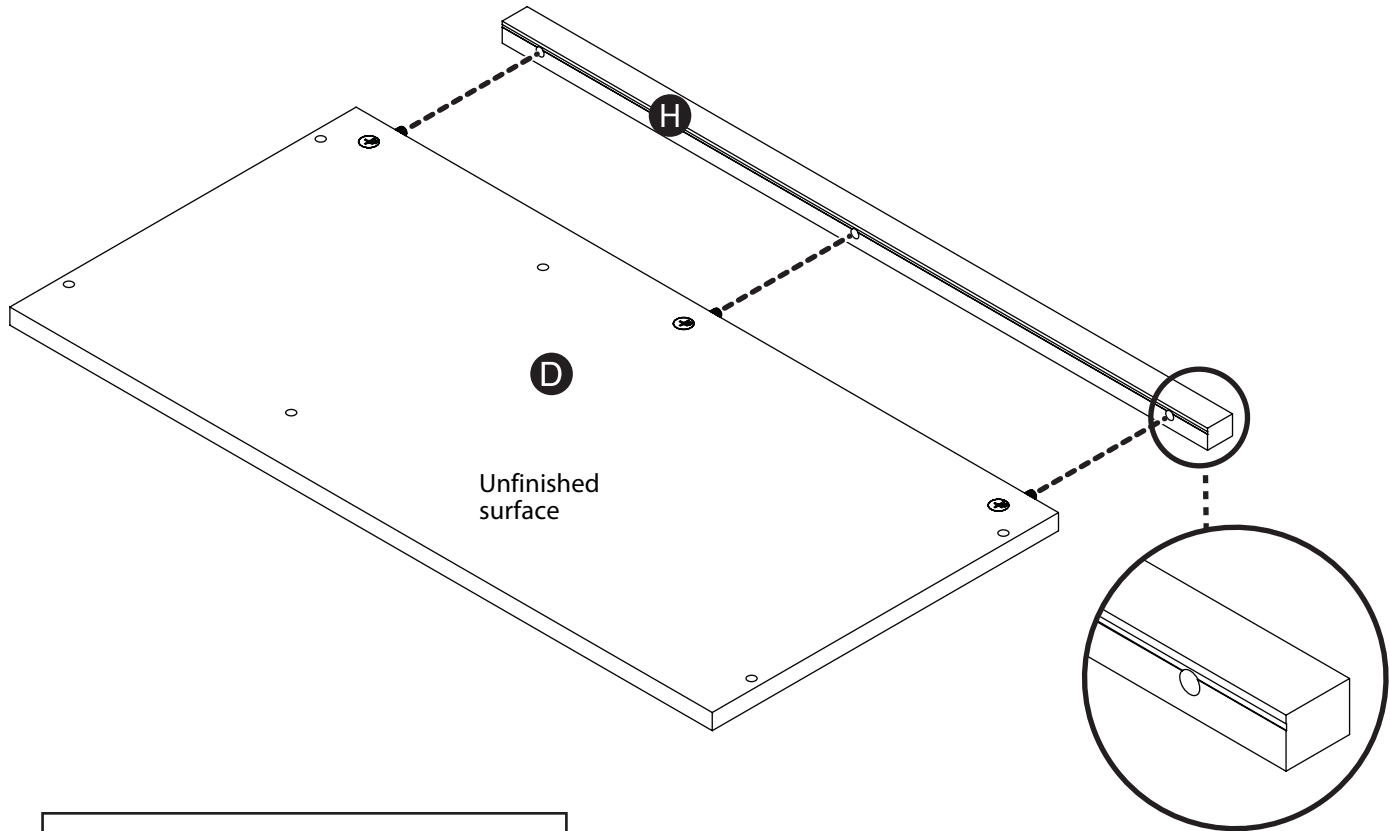
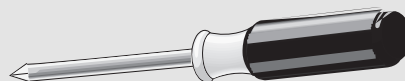
**You'll need:**

Phillips screwdriver

Need help? Call 800-305-2204

Step 4:

Fasten the left end (**B**) to the top (**D**). Use a Phillips screwdriver to tighten two hidden cams. See "Tightening hidden cams" on page 7.

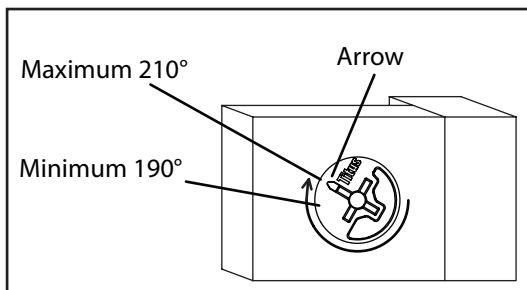
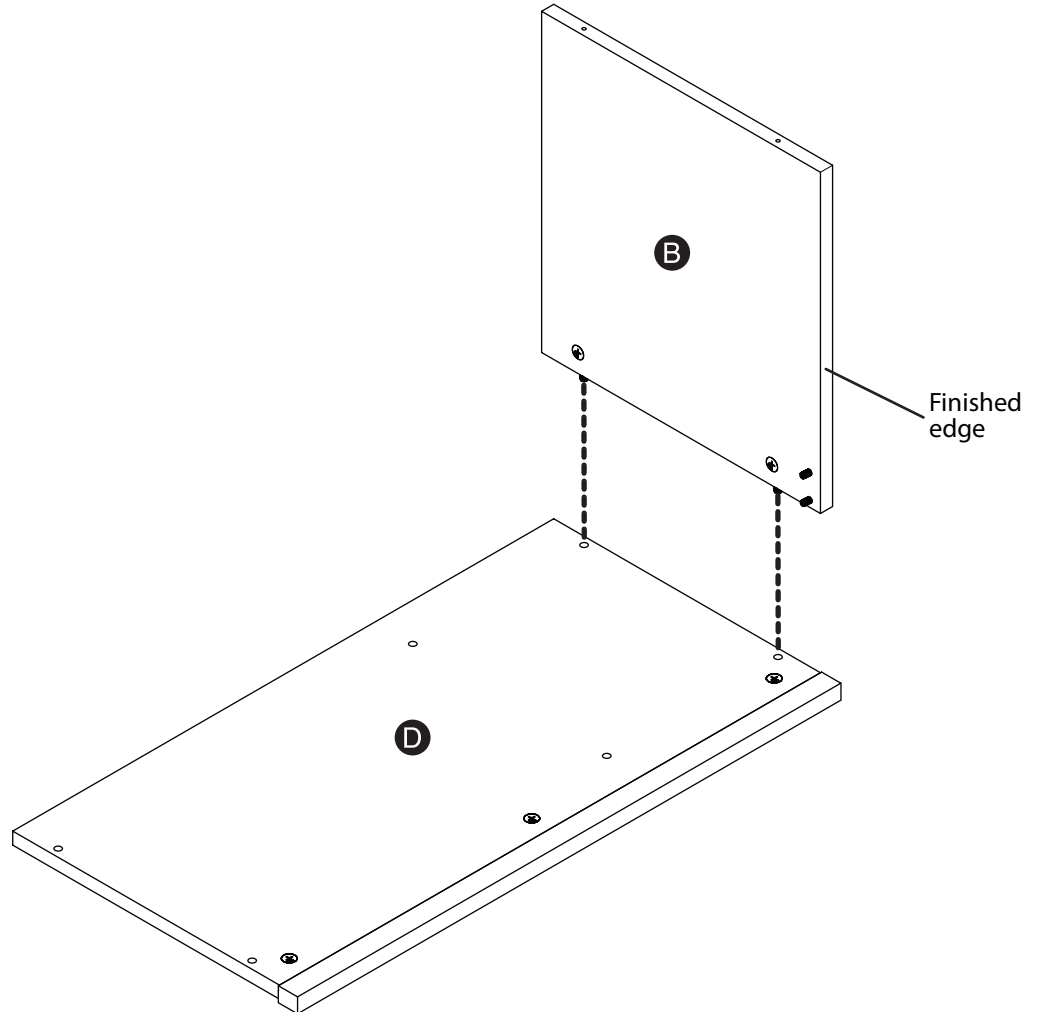
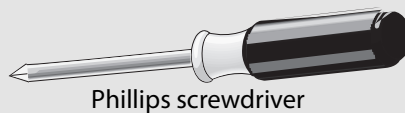
**You'll need:**

Phillips screwdriver

Need help? Call 800-305-2204

Step 5:

Slide the valance (**G**) onto the two metal pins (**M**) in the left end (**B**).

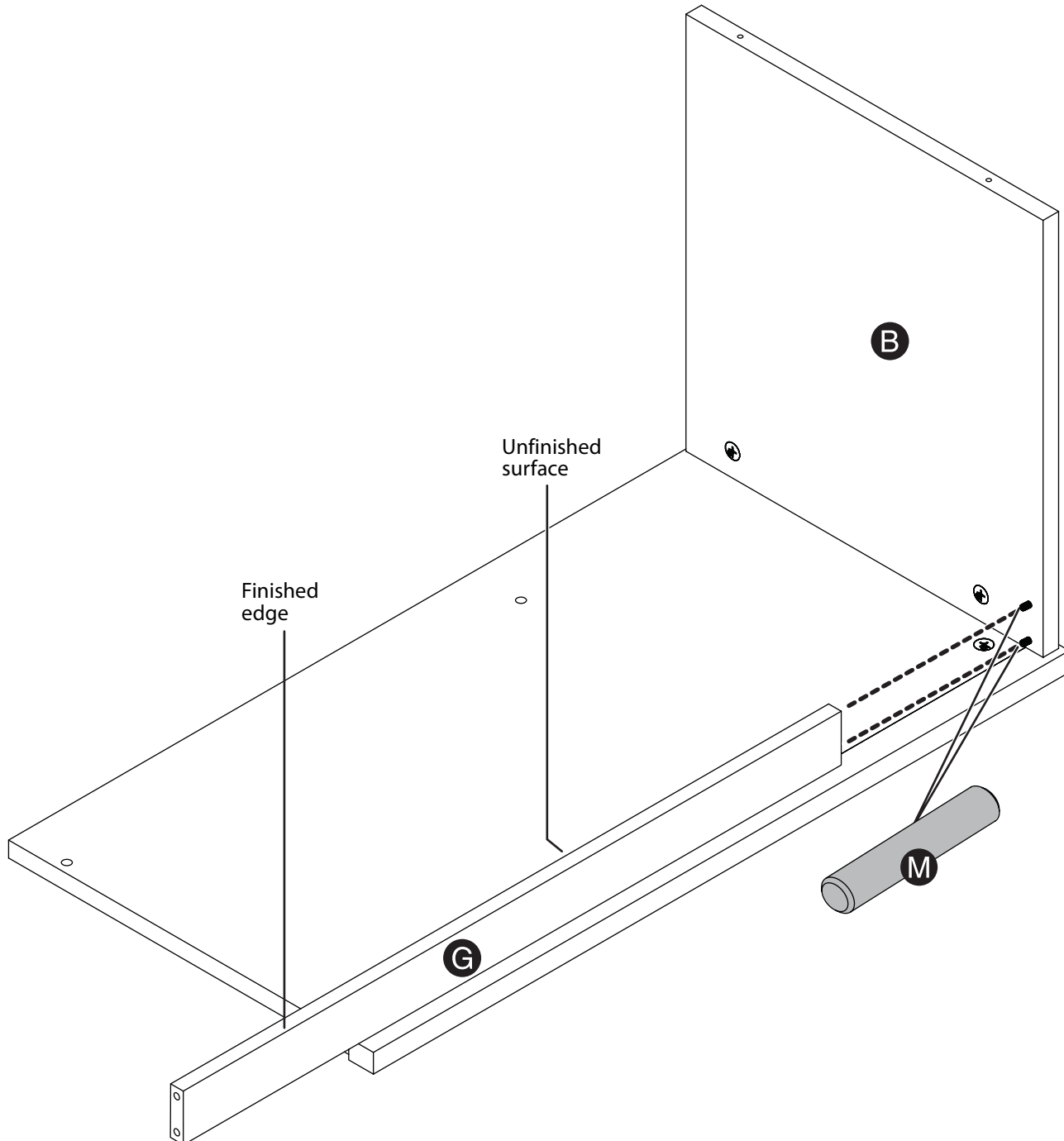

Need help? Call 800-305-2204

Step 6:

Fasten the right end (**A**) to the top (**D**). Use a Phillips screwdriver to tighten two hidden cams. See "Tightening hidden cams" on page 7.

Note: Make sure that the metal pins in the right end (**A**) insert into the holes in the valance (**G**).

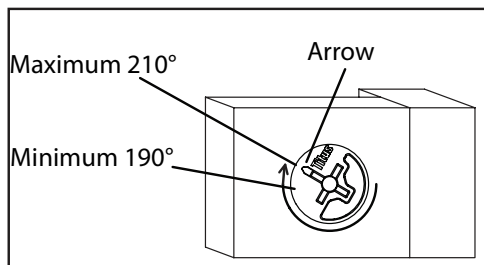
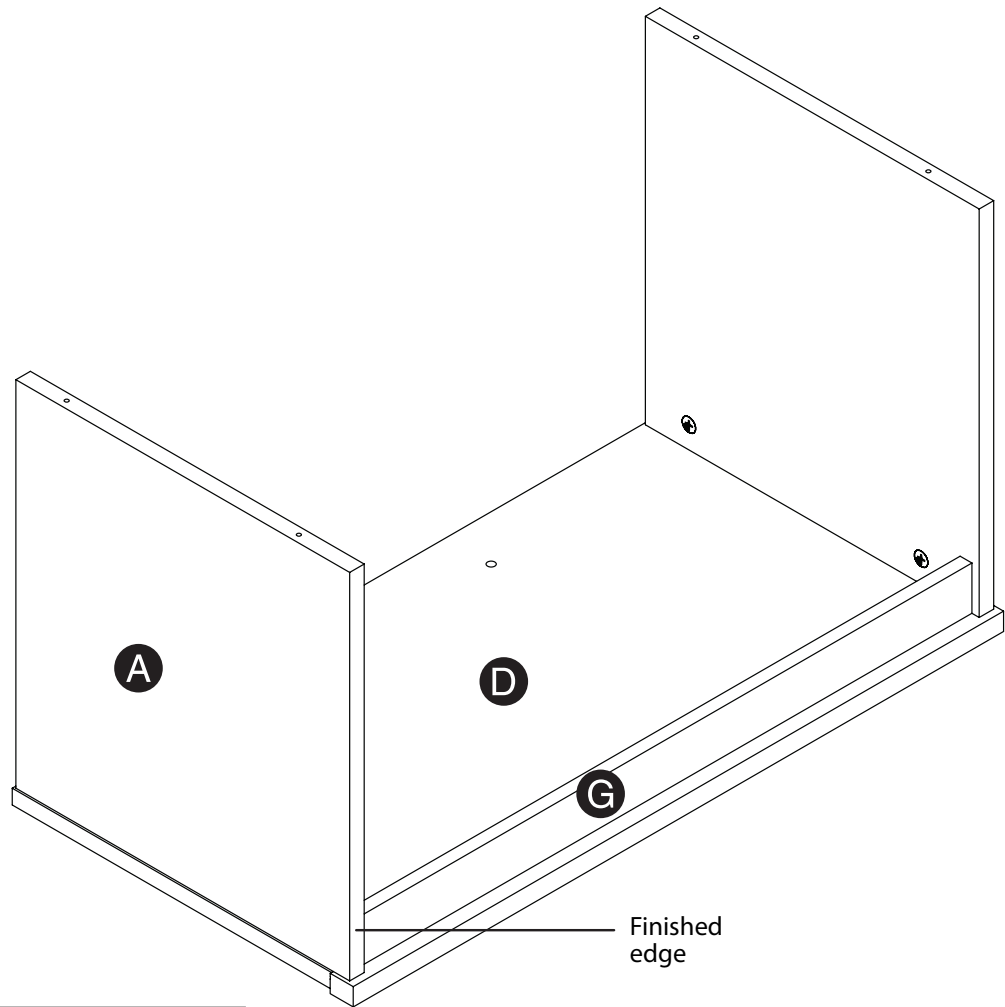

You'll need:

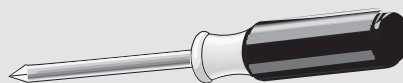

Phillips screwdriver

Need help? Call 800-305-2204

Step 7:

Fasten the upright (C) to the top (D). Use a Phillips screwdriver to tighten two hidden cams. See "Tightening hidden cams" on page 7.

Fasten the bottom (E) to the ends (A and B) and upright (C). Use a Phillips screwdriver and six black 1 7/8" flat head screws (P).

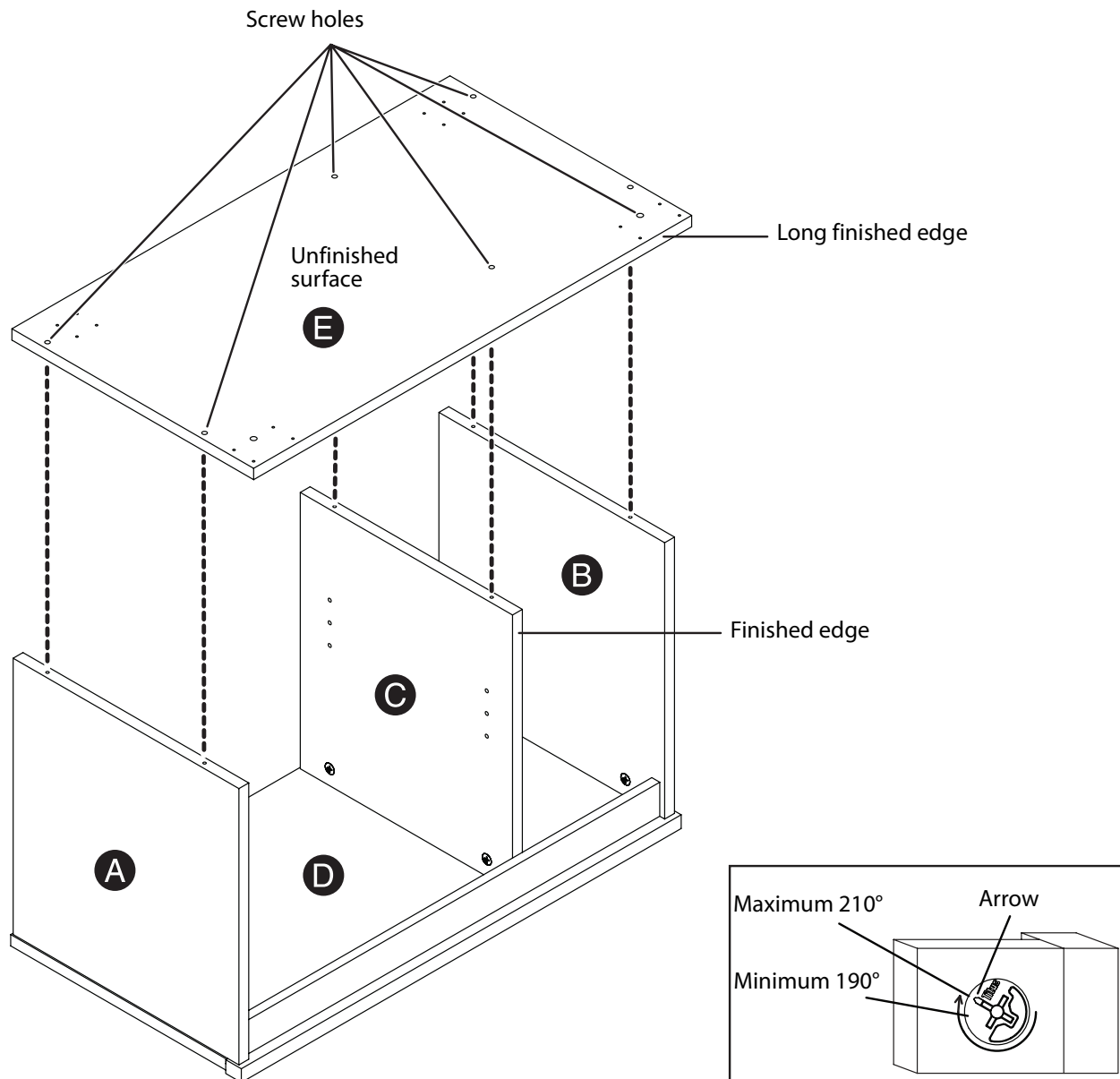

You'll need:

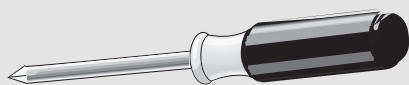

Phillips screwdriver

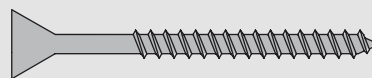

P (6)

Need help? Call 800-305-2204

Step 8:

Fasten the swivel casters (**K**) and the non-swivel casters (**L**) to the bottom (**E**). Use a Phillips screwdriver and 16 black 9/16" large head screws (**Q**) (four screws per caster).

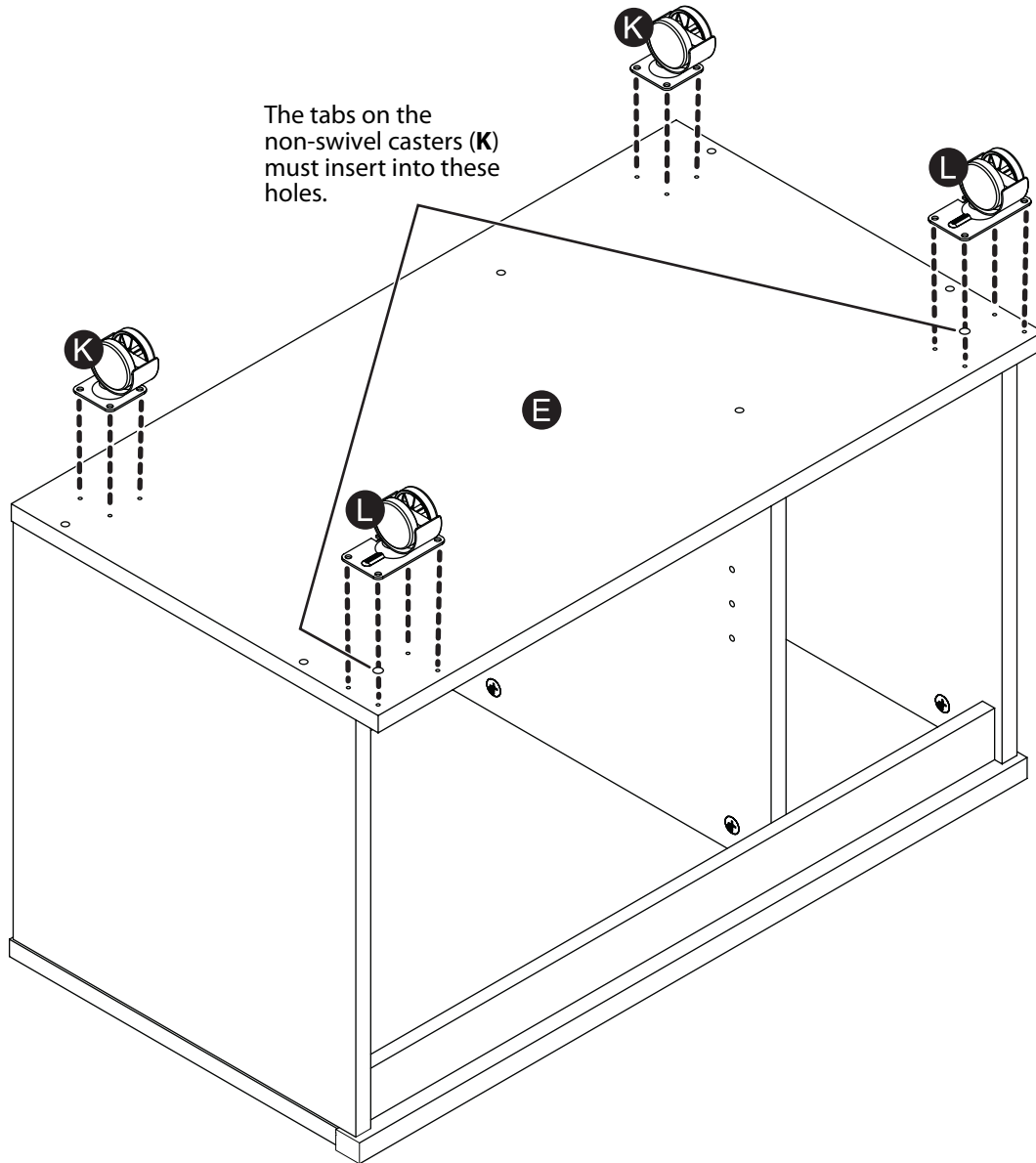
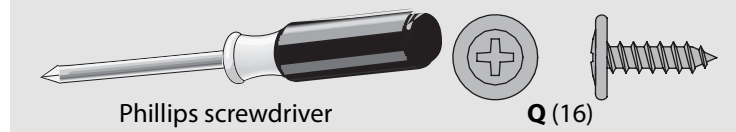
**You'll need:**

Need help? Call 800-305-2204

Step 9:

Carefully stand your TV cart upright.

Push the rubber sleeves (**N**) on the metal pins (**N**), then insert the metal pins into the hole locations of your choice in the right end (**A**) and upright (**C**). Set the adjustable shelf (**F**) onto the metal pins (**M**).

Apply the warning label (**O**) to the top (**D**). You should be able to read the label when the TV is removed from your TV cart. When the TV is in place, it should hide the label. Peel off the backing and apply the label as shown.

Caution: This is a permanent label intended to last for the life of the product. Once applied, do not try to remove it. You may damage the finish on the top.

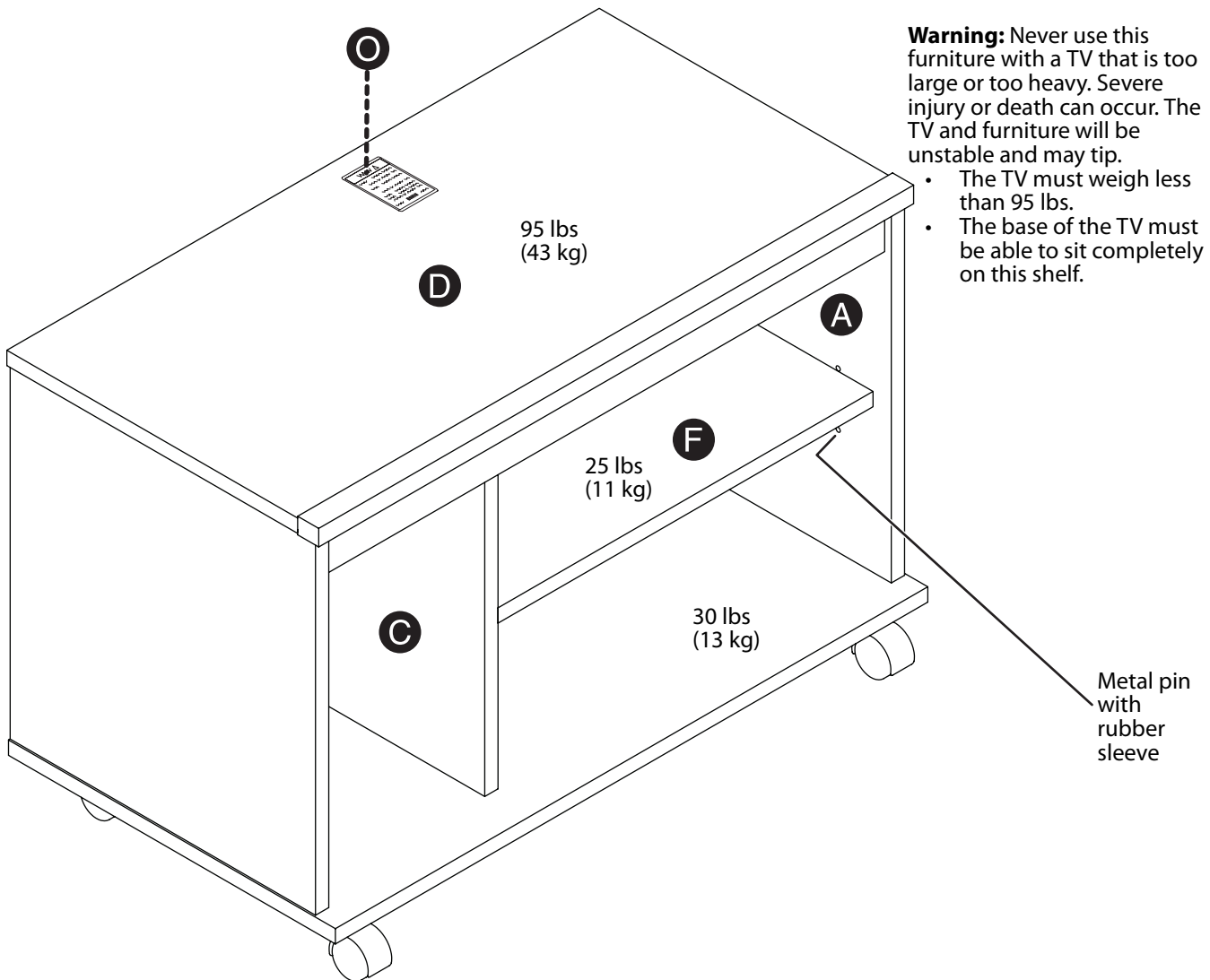

You'll need:

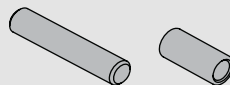

M (4)

N (4)

Need help? Call 800-305-2204

Still need help?

For customer service, call: 800-305-2204 (U.S./Canada markets)

Distributed by Best Buy Purchasing, LLC

7601 Penn Avenue South, Richfield, MN USA 55423-3645

© 2011 BBY Solutions, Inc.

All rights reserved. DYNEX is a trademark of BBY Solutions, Inc. Registered in some countries. All other products and brand names are trademarks of their respective owners.



Certificate of Conformity

1. This certificate applies to the Sauder Woodworking Product identified by this instruction booklet.
2. This certificate applies to the compliance of this product with the CPSC Ban on Lead-Containing Paint (16 CFR 1303).
3. This product was manufactured by:
Sauder Woodworking Company
502 Middle Street
Archbold, Ohio 43502
(419) 446-2711
4. Date of Manufacture: _____
Lot number: 346230

www.dynexproducts.com (800) 305-2204
Distributed by Best Buy Purchasing, LLC
7601 Penn Ave. South, Richfield, MN 55423 U.S.A.

© 2011 BBY Solutions, Inc.

All rights reserved.

DYNEX is a trademark of BBY Solutions, Inc. Registered in some countries. All other products and brand names are trademarks of their respective owners.

12-0784
ENGLISH

Free Manuals Download Website

<http://myh66.com>

<http://usermanuals.us>

<http://www.somanuals.com>

<http://www.4manuals.cc>

<http://www.manual-lib.com>

<http://www.404manual.com>

<http://www.luxmanual.com>

<http://aubethermostatmanual.com>

Golf course search by state

<http://golfingnear.com>

Email search by domain

<http://emailbydomain.com>

Auto manuals search

<http://auto.somanuals.com>

TV manuals search

<http://tv.somanuals.com>