

maintenance & service guide

Presario 1800 Series

Models: XL180, XL181, XL182, XL183, XL185,
and XL190, XL191, XL192

Before You
Begin

Product
Description

Specifications

Pin
Assignments

Battery & Power
Management

Troubleshooting

Removal &
Replacement

Parts
Catalog

MSG Index

Welcome to the Maintenance & Service Guide (MSG)



Welcome to the *Maintenance and Service Guide* (MSG) for Compaq Presario 1800XL Series Notebook Computers. This online guide is designed to serve the needs of technicians whose job is to repair Compaq products.

For copyright and trademark information, refer to the [Notice](#) section of this MSG. To locate your unit's serial number, to see symbol conventions, or to view technician's notes, see the [Preface](#). This MSG is updated online as needed.

For comments or questions about the contents of this MSG, [contact Compaq](#).

To report a technical problem, contact your Regional Support Center or IM Help Center.

For help on navigating in this guide, refer to [Using this Guide](#).

1.800.AT.COMPAQ

maintenance & service guide

Presario 1800 Series

Models: **XL180, XL181, XL182, XL183, XL185,**
and **XL190, XL191, XL192**

Using this Guide

To use this guide effectively, refer to the list of bookmarks at the left of the screen. These bookmarks help you navigate through the document quickly and easily. They are accessible from anywhere in the *Maintenance and Service Guide* (MSG).

Viewing a Chapter

Click one of the bookmarks or one of the color-coded bubbles on the [Welcome page](#) to view a chapter of this MSG.

Expanding & Hiding Topics

Click the **+** to expand or show the contents of a section, or click the **-** to hide the contents.

Opening another Chapter

Return to the [Welcome page](#) by clicking the bookmark, **1800 Series Maintenance and Service Guide**, and then click the bookmark or color-coded bubble for another chapter.

Printing the MSG

For portable copies of this MSG, you can print single pages, multiple pages, or the entire guide. In the Acrobat Reader, click **File**, and then **Print...** for printing options.

maintenance & service guide

Presario 1800 Series

Models: **XL180, XL181, XL182, XL183, XL185,**
and **XL190, XL191, XL192**

Before You Begin

Notice

The information in this guide is subject to change without notice.

COMPAQ COMPUTER CORPORATION SHALL NOT BE LIABLE FOR TECHNICAL OR EDITORIAL ERRORS OR OMISSIONS CONTAINED HEREIN, NOR FOR INCIDENTAL OR CONSEQUENTIAL DAMAGES RESULTING FROM THE FURNISHING, PERFORMANCE, OR USE OF THIS MATERIAL.

This guide contains information protected by copyright. No part of this guide may be photocopied or reproduced in any form without prior written consent from Compaq Computer Corporation.

©2000 Compaq Computer Corporation. All rights reserved. Printed in the U.S.A.

Compaq, Presario 1800 Series Registered U.S. Patent and Trademark Office.

Microsoft, MS-DOS, and Windows are registered trademarks of Microsoft Corporation. Windows 98 and Windows 2000 are trademarks of Microsoft Corporation.

The software described in this guide is furnished under a license agreement or nondisclosure agreement. The software may be used or copied only in accordance with the terms of the agreement.

Product names mentioned herein may be trademarks and/or registered trademarks of their respective companies.

Maintenance and Service Guide

Compaq Presario 1800 Series Notebook Computer

First Edition (July 2000) Compaq Computer Corporation

[privacy and legal statement](#)

1.800.AT.COMPAQ

maintenance & service guide

Presario 1800 Series

Models: **XL180, XL181, XL182, XL183, XL185,**
and **XL190, XL191, XL192**

Preface

This *Maintenance and Service Guide* is a troubleshooting guide for use as a reference when servicing the Compaq Presario 1800 Series Notebook Computers.

Compaq Computer Corporation reserves the right to make changes to the Compaq Presario 1800 Series Notebooks without notice.

Symbols

The following words and symbols mark special messages throughout this guide.



WARNING: Text set off in this manner indicates that a failure to follow directions in the warning could result in bodily harm or loss of life.



CAUTION: Text set off in this manner indicates that a failure to follow directions in the caution could result in damage to equipment or loss of data.

Important: Text set off in this manner presents clarifying information or specific instructions.

Note: Text set off in this manner presents commentary, sidelights, or interesting points of information.

Technician Notes



WARNING: Only authorized technicians trained by Compaq should repair this equipment. All troubleshooting and repair procedures are detailed to allow only subassembly/module-level repair. Because of the complexity of the individual boards and subassemblies, the user should not attempt to make repairs at the component level or to make modifications to any printed circuit board. Improper repairs can create a safety hazard. Any indications of component replacement or printed circuit board modifications may void any warranty.

maintenance & service guide

Presario 1800 Series

Models: XL180, XL181, XL182, XL183, XL185,
and XL190, XL191, XL192

Serial Number

The unit's serial number ❶ is required when requesting information or ordering spare parts. The serial number is located on the underside of the Notebook as shown below.

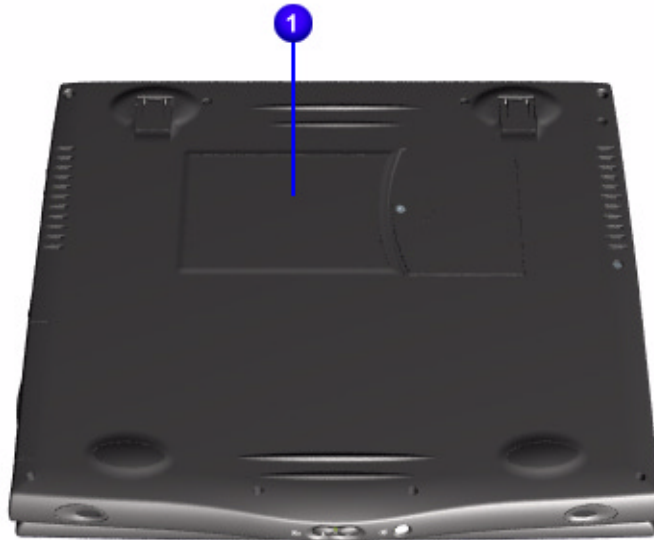

Locating Additional Information

The Compaq Presario 1800 Series Notebook Computer documentation set is available to support this product. It includes and is not limited to the following items:

- Beyond Setup Guide
- Compaq Service Advisories and Bulletins
- Operating System Guides (Compaq and Microsoft)
- Read-This-First Cards
- Service Training Guides
- Warranty Statement

maintenance & service guide

Presario 1800 Series

Models: **XL180, XL181, XL182, XL183, XL185,**
and **XL190, XL191, XL192**

Product Description

This chapter describes the features of each of the Presario 1800XL models. It also provides illustrations of the exterior components unique to these models.



1.800.AT.COMPAQ

maintenance & service guide

Presario 1800 Series
Models: XL180, XL181, XL182, XL183, XL185,
and XL190, XL191, XL192

Models and Features

Compaq Presario 1800 Series Portable Notebooks				
Feature	XL180	XL181	XL182	XL183
Display	15.0-in. TFT	15.0-in. TFT	15.0-in. TFT	15.0-in. TFT
Processor	PIII 600MHz, 256 Cache	PIII 500 MHz, 256 Cache	PIII 600 MHz, 256 Cache	PIII 600 MHz, 256 Cache
Hard Drive	6.0 GB	12.0 GB	12.0 GB	12.0 GB
CD or DVD Drive	6X DVD Drive	6X DVD Drive	6X DVD Drive	6X DVD Drive
Modem	56.0 Kbps Data/ Fax with PCI	56.0 Kbps Data/ Fax with PCI	56.0 Kbps Data/ Fax Int'l with PCI	56.0 Kbps Data/ Fax Int'l with PCI
Networking	10/100 TX Integrated Ethernet	10/100 TX Integrated Ethernet	10/100 TX Integrated Ethernet	10/100 TX Integrated Ethernet
Battery	3.2 Li-ion	3.2 Li-ion	3.2 Li-ion	3.2 Li-ion
System Memory	64 MB PC100	64 MB PC100	64 MB PC100	128 MB PC100

Compaq Presario 1800 Series Portable Notebooks				
Feature	XL185	XL190	XL191	XL192
Display	15.0-in. TFT	15.0-in. TFT	15.0-in. TFT	15.0-in. TFT
Processor	PIII 600 MHz, 256 Cache	PIII 700 MHz, 256 Cache	PIII 650 MHz 256 Cache	PIII 700 MHz 256 Cache
Hard Drive	12.0 GB	6.0 GB	12.0 GB	12.0 GB
CD or DVD Drive	6X DVD Drive	DVD Drive	6X DVD Drive	6X DVD Drive
Modem	56.0 Kbps Data/ Fax Int'l with PCI	56.0 Kbps Data/ Fax with PCI	56.0 Kbps Data/ Fax Int'l with PCI	56.0 Kbps Data/ Fax Int'l with PCI
Networking	10/100 TX Integrated Ethernet	10/100 TX Integrated Ethernet	10/100 TX Integrated Ethernet	10/100 TX Integrated Ethernet
Battery	3.2 Li-ion	3.2 Li-ion	3.2 Li-ion	3.2 Li-ion
System Memory	64 MB PC100	128 MB PC100	128 MB PC100	128 MB PC100

All models have a 3.5" Diskette Drive which uses 1.44Mb Diskettes.

maintenance & service guide

Presario 1800 Series
Models: **XL180, XL181, XL182, XL183, XL185,**
and **XL190, XL191, XL192**

Front of Unit

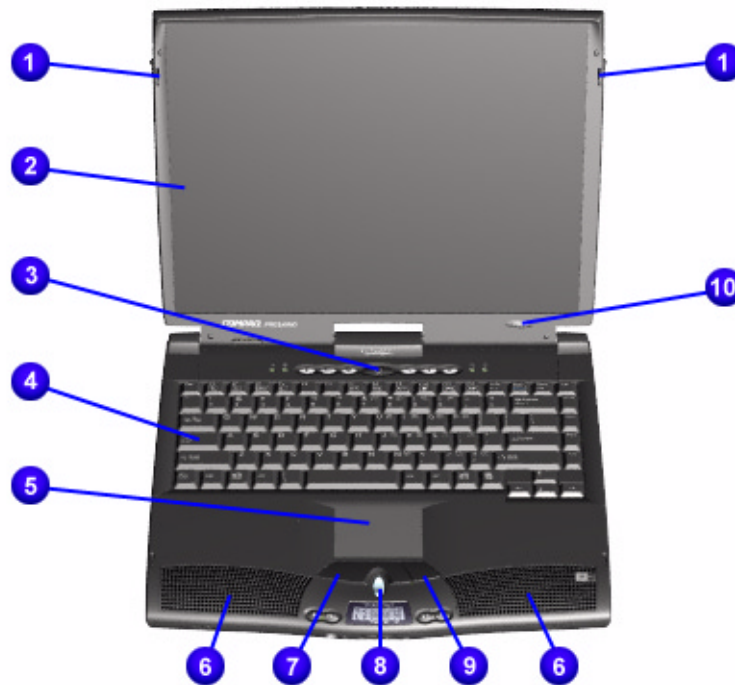

#	Description	#	Description
①	Display Release Latches	⑥	Integrated Speakers
②	Display	⑦	Left TouchPad Button
③	Power (On/Off) Button	⑧	Scroll Up/Down Button
④	Keyboard	⑨	Right TouchPad Button
⑤	TouchPad	⑩	Model Number

maintenance & service guide

Presario 1800 Series
Models: XL180, XL181, XL182, XL183, XL185,
and XL190, XL191, XL192

Internet Zone Buttons and Lights

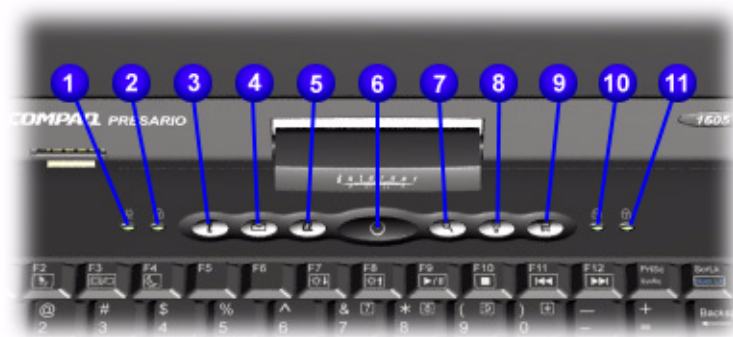

#	Description	#	Description
①	AC Adapter Light	⑦	Instant Search
②	Caps Lock Light	⑧	Online Marketplace (U.S./Puerto Rico) Instant Answer (outside U.S.)
③	Instant Internet Access	⑨	Retail Central (U.S./Puerto Rico) Instant E-Commerce (outside U.S.)
④	Instant E-mail Access	⑩	Num Lock Light
⑤	My Presario Instant Access	⑪	Scroll Lock Light
⑥	Power Button		

maintenance & service guide

Presario 1800 Series

Models: XL180, XL181, XL182, XL183, XL185,
and XL190, XL191, XL192

Front Bezel Components

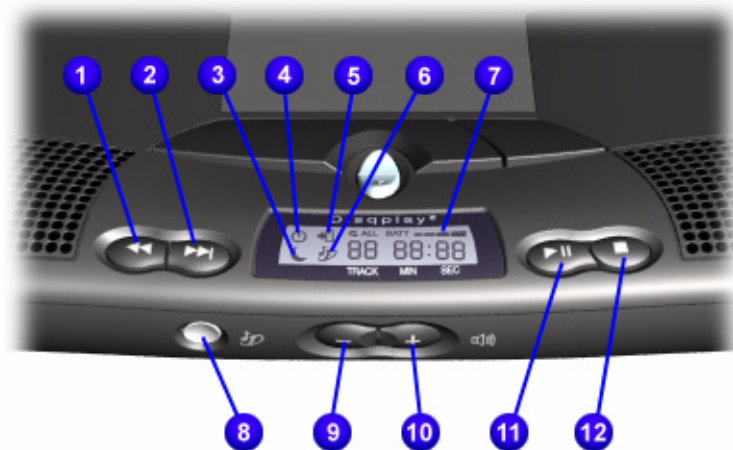

#	Description	#	Description
①	Previous Track Button	⑦	Battery Gauge
②	Next Track Button	⑧	DisqPlay On/Off Button
③	Sleep Status Icon	⑨	Volume Down Button
④	Power Status Icon	⑩	Volume Up Button
⑤	Battery Charging Status Icon	⑪	Play/Pause Button
⑥	DisqPlay Status Icon	⑫	Stop Button

maintenance & service guide

Presario 1800 Series

Models: XL180, XL181, XL182, XL183, XL185,
and XL190, XL191, XL192

Right-Side Components

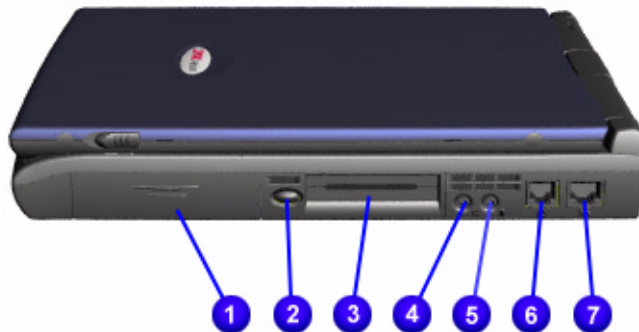

#	Description	#	Description
❶	Battery Compartment	❺	Microphone Jack
❷	PC Card Eject Button	❻	Modem Port
❸	PC Card Slot	❼	Ethernet Port
❹	Headphone Jack		

maintenance & service guide

Presario 1800 Series
Models: **XL180, XL181, XL182, XL183, XL185,**
and **XL190, XL191, XL192**

Left-Side Components

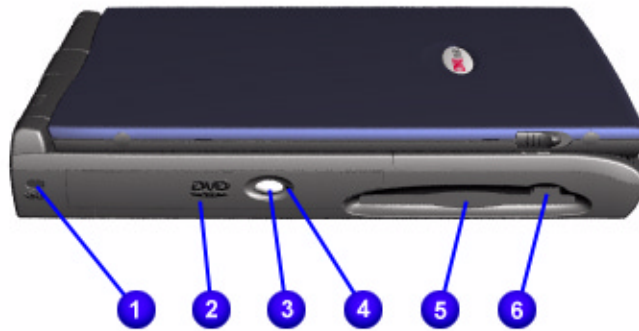

#	Description	#	Description
①	Security Slot	④	CD or DVD Manual Eject Hole
②	CD or DVD Drive	⑤	Diskette Drive
③	CD/DVD Drive Eject Button	⑥	Diskette Drive Eject Button

maintenance & service guide

Presario 1800 Series
Models: XL180, XL181, XL182, XL183, XL185,
and XL190, XL191, XL192

Underneath the Unit

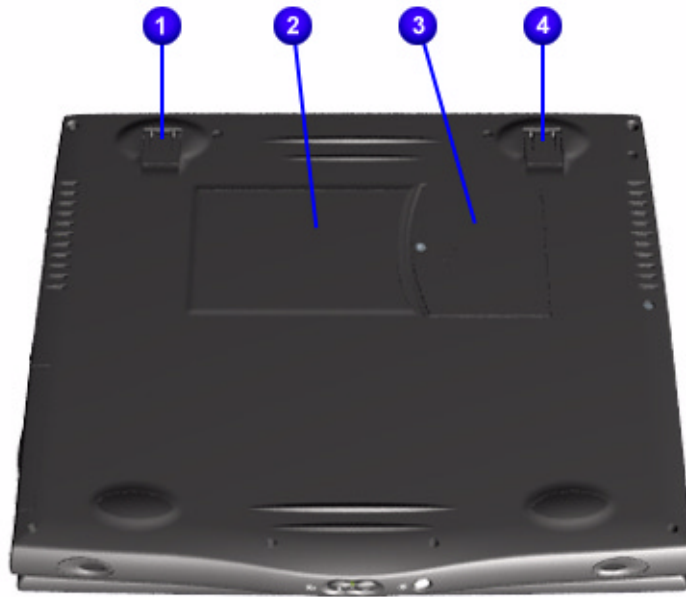

#	Description	#	Description
❶	Pop-up Foot	❸	Memory Compartment
❷	Serial Number Location	❹	Pop-up Foot

maintenance & service guide

Presario 1800 Series
Models: **XL180, XL181, XL182, XL183, XL185,**
and **XL190, XL191, XL192**

Rear Connectors

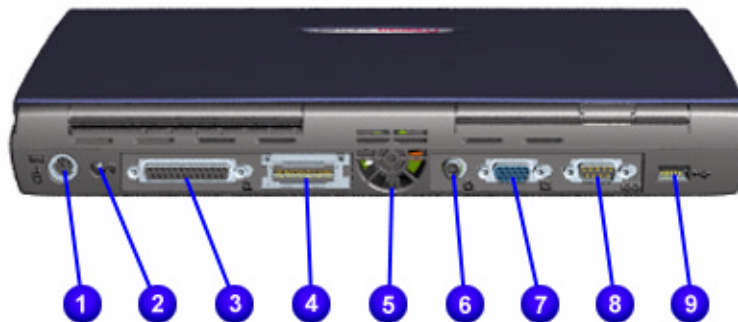

#	Description	#	Description
①	Keyboard/Mouse Port	⑥	TV-Out Connector
②	AC Adapter Connector	⑦	External Monitor Port
③	Parallel Port	⑧	Serial Ports
④	QuikDock Connector	⑨	Universal Serial Bus Port
⑤	Fan Vent		

maintenance & service guide

Presario 1800 Series

Models: XL180, XL181, XL182, XL183, XL185,
and XL190, XL191, XL192

Optional QuikDock

Components

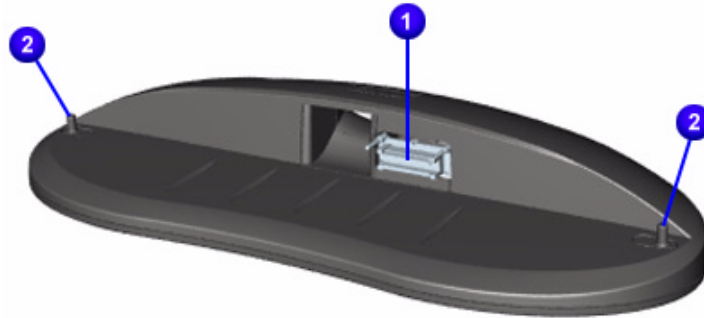

#	Description
①	QuikDock Interface Connector
②	QuikDock Guide Posts

Connectors



#	Description	#	Description
①	Universal Serial Bus Port	⑧	Serial Port
②	Universal Serial Bus Port	⑨	External Monitor Port
③	Power (AC Adapter) Connector	⑩	10/100TX Ethernet
④	Keyboard/Mouse Port	⑪	S-Video
⑤	Keyboard/Mouse Port	⑫	TV-Out (Composite Video)
⑥	Parallel Port	⑬	Audio Out
⑦	Game Port		

maintenance & service guide

Presario 1800 Series
Models: XL180, XL181, XL182, XL183, XL185,
and XL190, XL191, XL192

Specifications

Physical and Environmental

Specification	U.S.	Metric
Height	1.63 in	4.14 cm
Depth	12.99 in	33.00 cm
Width	11.02 in	28.00 cm
Weight: with 14.1" TFT Display with 15.0" Display	7.8 lbs	3.54 kg
Battery Power Requirements: Nominal Operating Maximum Average Peak Operating	Li-ion 3.2 Ahr W @ 14.8 V W @ 14.8 V W @ 14.8 V	
AC Power Requirements: Operating Voltage Operating Current Operating Frequency Maximum Transient	100-240 V 0.8/0.4 A RMS 47-63 Hz (meets IEC801-4 & 5) 1kV for 50 ns	
Operating Temperature* Non-Operating Temperature*	50° to 95°F -4° to 140°F	10° to 35°C -20° to 60°C
Relative Humidity (noncondens.): Operating Non-Operating (tw = 38.7°C max)	10 to 90% 5 to 95%	35 to 90% 60 to 95%
Operating Altitude Non-Operating Altitude	0 to 10,000 ft 0 to 30,000 ft	0 to 3.05 km 0 to 9.14 km
Operating Shock Non-Operating Shock	10 G, 11 ms, half sine 240 G, 2 ms, half sine	
Operating Vibration Non-Operating Vibration	0.5 G 1.5 G	

**Applicable safety standards specify thermal limits for plastic surfaces.
 Presario 1800XL Notebooks operate well within this temperature range.*

1.800.AT.COMPAQ

maintenance & service guide

Presario 1800 Series
Models: XL180, XL181, XL182, XL183, XL185,
and XL190, XL191, XL192

System Interrupts

Hardware IRQ	System Function	Hardware IRQ	System Function
IRQ0	System Timer	IRQ10	Available
IRQ1	Standard 101/102-Key or Microsoft Natural Keyboard	IRQ11	Intel® Pro/100S Mobile LAN on Motherboard
IRQ2	Programmable Interrupt Controller	IRQ11	Texas Instruments PCI-1410 CardBus Controller
IRQ3	Lucent 56K V.90 PCI DF Modem	IRQ11	ACPI IRQ Holder for PCI IRQ Steering
IRQ3	ACPI IRQ Holder for PCI IRQ Steering	IRQ11	Intel® 82371AB/EB PCI to USB Universal Host Controller
IRQ4	Communications Port (COM1)	IRQ11	ACPI IRQ Holder for PCI IRQ Steering
IRQ5	ESS SOLO-1 PCI AudioDrive	IRQ12	Synaptics PS/2 TouchPad
IRQ5	ACPI IRQ Holder for PCI IRQ Steering	IRQ13	Numeric Data Processor
IRQ5	RAGE Mobility AGP (English)	IRQ14	Intel® 82371AB/EB PCI Bus Master IDE Controller
IRQ6	Standard Floppy Disk Controller	IRQ14	Primary IDE Controller (Dual FIFO)
IRQ7	Printer Port (LPT1)	IRQ15	Intel 82371AB/EB PCI Bus Master IDE Controller
IRQ8	System CMOS/Real Time Clock	IRQ15	Secondary IDE Controller (Dual FIFO)
IRQ9	SCI IRQ used by ACPI Bus		

System DMA

Hardware DMA	System Function
DMA1	ESS SOLO-1 DOS Emulation
DMA2	Standard Floppy Disk Controller
DMA3	ECP Printer Port (LPT1)
DMA4	Direct Memory Access Controller

maintenance & service guide

Presario 1800 Series

Models: **XL180, XL181, XL182, XL183, XL185,**
and **XL190, XL191, XL192**

System I/O Address

I/O Address	System Function (Shipping Configuration)
0000h - 000Fh	Direct Memory Access Controller
0020h - 0021h	Programmable Interrupt Controller
0040h - 0043h	System Timer
0060h - 0060h	Standard 101/102-Key or Microsoft Natural Keyboard
0061h - 0061h	System Speaker
0062h - 0062h	ACPI Embedded Controller
0064h - 0064h	Standard 101/102-Key or Microsoft Natural Keyboard
0066h - 0066h	ACPI Embedded Controller
0070h - 0071h	System CMOS/Real Time Clock
0081h - 008Fh	Direct Memory Controller
00A0h - 00A1h	Programmable Interrupt Controller
00C0h - 00DFh	Direct Memory Access Controller
00F0h - 00FEh	Numeric Data Processor
0170h - 0177h	Intel® 82371AB/EB PCI Bus Master IDE Controller
0170h - 0177h	Secondary IDE Controller (Dual Fifo)
01F0h - 01F7h	Intel® 82371AB/EB PCI Bus Master IDE Controller
01F0h - 01F7h	Primary IDE Controller (dual fifo)
0200h - 0203h	Gameport Joystick
0220h - 022Fh	ESS SOLO-1 DOS Emulation
0330h - 0331h	ESS SOLO-1 DOS Emulation
0376h - 0376h	Secondary IDE Controller (Dual FIFO)
0376h - 0376h	Intel® 82371AB/EB PCI Bus Master IDE Controller
0378h - 037Fh	Printer Port (LPT1)
0388h - 038Bh	ESS SOLO-1 DOS Emulation
03B0h - 03BBh	RAGE Mobility AGP (English)
03C0h - 03DFh	RAGE Mobility AGP (English)
03F0h - 03F5h	Standard Floppy Disk Controller
03F6h - 03F6h	Intel® 82371AB/EB PCI Bus Master IDE Controller
03F6h - 03F6h	Primary IDE Controller (Dual FIFO)
03F7h - 03F7h	Standard Floppy Disk Controller

maintenance & service guide

Presario 1800 Series
Models: XL180, XL181, XL182, XL183, XL185,
and XL190, XL191, XL192

I/O Address	System Function (Shipping Configuration)
03F8h - 03FFh	Communications Port (COM1)
04D0h - 04D1h	Motherboard Resources
0CF8h - 0CFFh	PCI Bus
1000h - 10FFh	Lucent 56K V.90 PCI DF Modem
1400h - 143Fh	ESS SOLO-1 PCI AudioDrive
1440h - 147Fh	Intel® PRO/100 S Mobile LAN on Motherboard
1480h - 149Fh	Intel® 82371AB/EB PCI to USB Universal Host Controller
14A0h - 14A7h	Primary IDE Controller (Dual FIFO)
14A0h - 14AFh	Intel® 82371AB/EB PCI Bus Master IDE Controller
14A8h - 14AFh	Secondary IDE Controller (Dual FIFO)
14B0h - 14BFh	ESS SOLO-1 PCI AudioDrive
14C0h - 14CFh	ESS SOLO-1 PCI AudioDrive
14D0h - 14D7h	Lucent 56K V.90 PCI DF Modem
14D8h - 14DBh	ESS SOLO-1 PCI AudioDrive
14DCh - 14DFh	ESS SOLO-1 PCI AudioDrive
2180h - 218Fh	Motherboard Resources
8000h - 803Fh	Motherboard Resources
9000h - 9FFFh	Intel® 82443BX Pentium® III Processor to AGP Controller
9000h - 90FFh	RAGE Mobility AGP (English)

System Memory Catalog

Memory Address	System Function
00000000h - 0009FFFFh	Not Available For Use By Devices
000A0000h - 000AFFFFh	RAGE Mobility AGP (English)
000B0000h - 000BFFFFh	RAGE Mobility AGP (English)
000C0000h - 000CBFFFh	RAGE Mobility AGP (English)
000E0000h-000E7FFFh	Not Available For Use By Devices
000E9000h-03FFFFFFh	Not Available For Use By Devices
04000000h - 04000FFFh	Texas Instruments PCI-1410 CardBus Controller
F4000000h - F4000FFFh	Intel® PRO/100 S Mobile LAN on Motherboard
F4100000h-F4100FFFh	Intel® PRO/100 S Mobile LAN on Motherboard

maintenance & service guide

Presario 1800 Series
Models: XL180, XL181, XL182, XL183, XL185,
and XL190, XL191, XL192

Memory Address	System Function
F4101000h-F41010FFh	Lucent 56K V.90 PCI DF Modem
F4200000h-F4200FFFh	RAGE Mobility AGP (English)
F4200000h-F5FFFFFFh	Intel® 82443BX Pentium® III Processor to AGP Controller
F4220000h-F423FFFFh	RAGE Mobility AGP (English)
F5000000h-F5FFFFFFh	RAGE Mobility AGP (English)
F8000000h - FBFFFFFFh	Intel® 82443BX Pentium® III Processor to PCI Bridge
FFF80000h - FFFFFFFFh	Motherboard Resources

Display Information

Specifications	15.0-in. (Diagonal) TFT with LVDS	14.1-in. (Diagonal) TFT with LVDS
Unit Height	9.48 in. (24.05 cm)	8.92 in. (22.65 cm)
Unit Width	12.43 in. (31.55 cm)	11.76 in. (29.85 cm)
Display Height	8.99 in. (22.81 cm)	8.44 in. (21.43 cm)
Display Width	11.98 in. (30.41 cm)	11.26 in. (28.57 cm)
Weight	24.36 oz (690 g)	19.94 oz (565 g)
Contrast Ratio	150:1 mini	150:1 mini
Brightness	120 cd/mm ³	120 cd/mm ³
Response Time	50 ms	50 ms
Refresh Rate	60 Hz	60 Hz

maintenance & service guide

Presario 1800 Series

Models: XL180, XL181, XL182, XL183, XL185,
and XL190, XL191, XL192

Memory Expansion

Memory Expansion		
System Memory	Expansion Board Memory	Total Memory
64 MB	none	64 MB
64 MB	32 MB	96 MB
64 MB	64 MB	128 MB
64 MB	128 MB	192 MB
64 MB	256 MB	320 MB

Diskette Drive

Diskette Drive	
Capacity per Diskette (High/Low)	1.44Mb/720 Kb
Diskette Size	3.5 in
Number of LED Indicators	0
Number of Drives Supported	1
Drive Rotation (rpm)	300
Transfer Rate (Kbps)	500
Bytes per Sector	512
Sectors per Track (High/Low)	18/9
Tracks per Side (High/Low)	80
Access Times	
Track-to-Track (ms)	3
Average (ms)	94
Setting Time (ms)	15
Latency Average (ms)	100
Cylinders (High/Low)	80
Number of Read/Write Heads	2

maintenance & service guide

Presario 1800 Series
Models: XL180, XL181, XL182, XL183, XL185,
and XL190, XL191, XL192

Hard Drive

Hard Drives			
Specification	6.0 GB	12.0 GB	18.0 GB
Drive Type	Ultra DMA 66.7	Ultra DMA 66.7	Ultra DMA 66.7
Cylinders	15200	15200	15200
Heads	2	4	6
Sectors per Track	63	63	63
Bytes per Sector	512	512	512
Seek Times (typical)			
Read/Write (incl. settling)	13 ms	13 ms	13 ms
Single track	3 ms	3 ms	3 ms
Full stroke	24 ms	24 ms	24 ms
Transfer Rate at Interface			
Ultra DMA mode (max)	66.7 Mb/s	66.7 Mb/s	66.7 Mb/s
PIO mode	16.6 Mb/s	16.6 Mb/s	16.6 Mb/s

CD or DVD Drive

CD or DVD Drive				
Specification	6x DVD	8x DVD	CD-RW	24x CD
Width	128 mm	128 mm	128 mm	128 mm
Height	12.7 mm	12.7 mm	12.7 mm	12.7 mm
Depth	129 mm	129 mm	129 mm	129 mm
Weight	280 g	270 g	300 g	<270 g
Rotational Speed Approx.	3450 rpm	2300 rpm	4200 rpm (CD)	4225 rpm
Sustained Data Transfer Rate (typical)	8100 Kb/s	5400Kb/s	Reading: 3000 Kb/s (20x CD) 2100 Kb/s (14x CD-RW) Writing:600 Kb/s (4x)	3600 Kb/s
Random Access Time (Avg.)	140 ms	140 ms	150 ms (Typ.)	120 ms
Spin Up Time	<15 s	3.8 s	<10 s	2.7 s
Data Buffer Capacity	512 Kb	128 Kb	2Mb	128 Kb

maintenance & service guide

Presario 1800 Series

Models: **XL180, XL181, XL182, XL183, XL185,**
and **XL190, XL191, XL192**

Battery Pack

Battery Pack	
Type	Lithium Ion (Li-Ion)
Height	0.8 in (20.3 mm)
Length	5.7 in (145 mm)
Width	3.1 in (78.7 mm)
Weight	0.90 lb (408.2 g)
Discharge/Use Limit*	2 hr 30 min*
Energy	
Circuit Voltage	14.4 V
Capacity	3000 mAH
Power	43.2 WH
Temperature Requirements	
Operating	32°F (0-50° C)
Non-Operating	-20°C - 60° C
Charging	5°C - 45° C

**The battery discharge/use limit changes depending on the power management settings, system components such as installed PC cards, and the applications in use.*

maintenance & service guide

Presario 1800 Series
Models: XL180, XL181, XL182, XL183, XL185,
and XL190, XL191, XL192

Pin Assignments

This chapter provides the pin assignments for the Presario 1800XL Series Notebook connectors. For more information on connectors or external ports, refer to [Rear Connectors](#) and [QuikDock Connectors](#).

Note: The signals in all tables of this chapter are considered active high unless otherwise indicated by an asterisk (*).

Parallel Connector

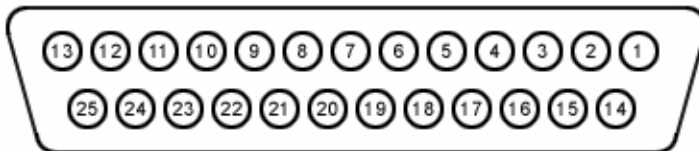

Pin	Signal	Pin	Signal
1	Strobe*	10	Acknowledge*
2	Data Bit 0	11	Busy
3	Data Bit 1	12	Paper Out
4	Data Bit 2	13	Select
5	Data Bit 3	14	Auto Linefeed*
6	Data Bit 4	15	Error*
7	Data Bit 5	16	Initialize Printer*
8	Data Bit 6	17	Select In*
9	Data Bit 7	18-25	Signal Ground

**Signal is active low.*

maintenance & service guide

Presario 1800 Series

Models: XL180, XL181, XL182, XL183, XL185,
and XL190, XL191, XL192

Serial Connector

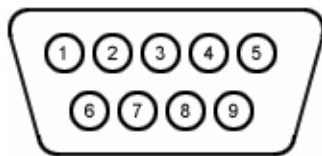

Pin	Signal	Pin	Signal
1	Carrier Detect	6	Data Set Ready
2	Receive Data	7	Ready to Send
3	Transmit Data	8	Clear to Send
4	Data Terminal Ready	9	Ring Indicator
5	Signal Ground		

Keyboard/Mouse Connector



Pin	Signal	Pin	Signal
1	Data 1	4	+5 V
2	Data 2	5	Clock 1
3	Ground	6	Clock 2

maintenance & service guide

Presario 1800 Series

Models: XL180, XL181, XL182, XL183, XL185,
and XL190, XL191, XL192

Modem Connector

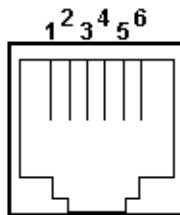

Pin	Signal	Pin	Signal
1	Unused	4	Unused
2	Tip	5	Unused
3	Ring	6	Unused

Game Port Connector

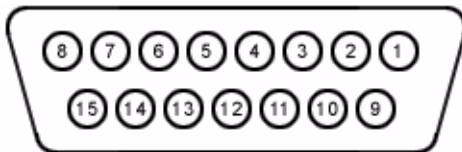

Pin	Signal	Pin	Signal
1	+5V	9	+5V
2	SWA	10	SWC
3	RBTA	11	RBTC
4	GND	12	RMSO
5	GND	13	RBTD
6	RBTB	14	SWD
7	SWB	15	RMSI
8	+5V		

maintenance & service guide

Presario 1800 Series

Models: XL180, XL181, XL182, XL183, XL185,
and XL190, XL191, XL192

External VGA Monitor Port

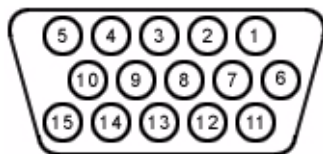

Pin	Signal	Pin	Signal
1	Red Analog	9	+5V
2	Green Analog	10	Ground
3	Blue Analog	11	Monitor Detect
4	Not connected	12	DDC2B Data
5	Ground	13	Horizontal Sync
6	Ground Analog	14	Vertical Sync
7	Ground Analog	15	DDC2B Clock
8	Ground Analog		

S-Video Connector



Pin	Signal	Pin	Signal
1	Ground	3	SYR
2	Ground	4	SCG

maintenance & service guide

Presario 1800 Series
Models: **XL180, XL181, XL182, XL183, XL185,**
and **XL190, XL191, XL192**

TV-Out (Composite Video) Connector



Pin	Signal	Pin	Signal
1	Ground	3	Ground
2	Composite		

Univeral Serial Bus (USB)

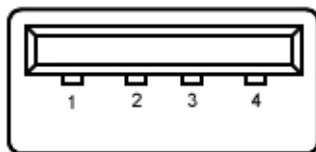

Pin	Signal	Pin	Signal
1	+5V	3	Data +
2	Data -	4	Ground

maintenance & service guide

Presario 1800 Series

Models: **XL180, XL181, XL182, XL183, XL185,**
and **XL190, XL191, XL192**

QuikDock Connector

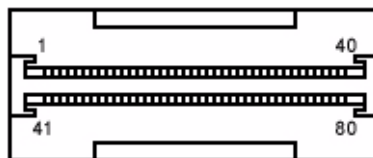

Pin	Signal	Pin	Signal	Pin	Signal	Pin	Signal
1	Adapter Power	22	Serial Port DCD	43	Keyboard Clock	64	Reserved
2	Adapter Power	23	Serial Port DSR	44	Keyboard Data	65	Headphone Sense
3	Adapter Power	24	Serial Port TXD	45	Mouse Clock	66	USB Power
4	Adapter Power	25	Serial Port RTS	46	Mouse Data	67	USB Power
5	Adapter Power	26	Monitor DDC	47	Lp Indicator	68	USB Power
6	Adapter Power	27	Monitor DDC	48	Lp Paper End	69	USB Power
7	Not Connected	28	Monitor Indicator	49	Lp Initialize	70	USB A-
8	Printer Data 0	29	V.SYNC	50	Lp Busy	71	USB A+
9	Printer Data 1	30	Ground	51	Lp Error	72	USB B-
10	Printer Data 2	31	H.SYNC	52	Lp Acknowledge	73	USB B+
11	Printer Data 3	32	Ground	53	Lp AutoFeed	74	5V
12	Printer Data 4	33	Blue	54	Lp Strobe	75	5V
13	Printer Data 5	34	Ground	55	Joystick Data A	76	Line Out Left
14	Printer Data 6	35	Green	56	Joystick Data B	77	S-Video SYR
15	Printer Data 7	36	Ground	57	Joystick Data C	78	Ground
16	Lp Select	37	Red	58	Joystick Data D	79	S-Video SCG
17	QuikDock Indicator	38	Ground	59	Switch A	80	Ground
18	Serial Port RXD	39	Composite TV-Out	60	Switch B		
19	Serial Port RI	40	Line Out Right	61	Switch C		
20	Serial Port DTR	41	Line Out Present	62	Switch D		
21	Serial Port CTS	42	Reserved	63	Reserved		

maintenance & service guide

Presario 1800 Series

Models: **XL180, XL181, XL182, XL183, XL185,**
and **XL190, XL191, XL192**

Battery and Power Management

This chapter describes power management and proper battery operating practices for Presario 1800XL Series Notebooks. These practices include conservation of AC power and extending the operating life of the battery. The following sections also outline proper methods to start and shut down the Notebook in various situations.

Power Modes

Presario 1800XL Series Notebooks have three levels of low power: *Hibernation*, *Standby*, and *Off*.

Hibernation

Hibernation helps conserve battery life and protect data. The Notebook automatically enters Hibernation mode when the battery has little power left or when the Notebook (operating on battery power) is in Standby mode for more than one hour. As the Notebook enters Hibernation, it automatically stores the contents of its memory to the hard drive before shutdown. When the Notebook wakes from Hibernation, it returns to its former state.

Note: When the Notebook enters or wakes from Hibernation mode, a Progress window is displayed.

To activate Hibernation mode, press the **Power** button once.

To resume from Hibernation mode, press the **Power** button once.

Standby

Standby is a low-power mode, also referred to as *Sleep* mode. The Notebook maintains system information and open files while in Standby mode. Selecting Standby mode instead of turning off the Notebook when finished has two advantages: 1. It allows the Notebook to wake up faster than turning it off; 2. It saves more power than the Active-On mode.

 **CAUTION:** Unsaved information is lost if the Notebook is turned off prior to system wake-up, or if a power loss occurs while using the AC adapter.

To activate Standby/Sleep mode, press **Fn+F4** or click **Start**, select the **Shut Down** option, and then **Standby**.

To resume from Standby/Sleep mode, press any key.

1.800.AT.COMPAQ

maintenance & service guide

Presario 1800 Series

**Models: XL180, XL181, XL182, XL183, XL185,
and XL190, XL191, XL192**

Full Off

Off mode consumes no power. However, the battery charges while the Notebook is in Off mode if the battery is installed and the Notebook remains plugged into external AC power.

Note: Unsaved information is lost if the Notebook is shutdown without saving the data.

To activate Off mode, click the **Start** button on the Windows taskbar, click **Shut Down**, and then select **shutdown** from the options.







To resume from Off mode, press the **Power** button once.



WARNING: The Notebook must be shutdown (Off mode) when installing or replacing components. Follow the instructions for putting the Notebook into Off mode, unplug it from the outlet, and remove the battery pack (see [Removing the Battery](#) later in this guide) before servicing any parts.

Summary of Power Modes

The following table outlines entering and exiting the various power modes and the external indicators for each mode.

	Standby Mode	Hibernation Mode	Off Mode
Automatic Activation	15 minutes if using battery power* (preset default)	When battery is low or after 1 hour of Standby*.	Standard Shutdown: click Start on the Windows taskbar, click Shut Down , and then Shut down .
Manual Activation	Press Fn+F4 key combination or click Start on the Windows taskbar, Shut Down , and then Standby .	Press Power  button once.	Manual Shutdown**: Press and hold down the Power  button for 4 seconds.
Resume/Exit	Press any key.	Press Power  button once.	Press Power  button once.
Indicators	Power light flashes and Moon  icon appears on status display.	Power light is off, screen is blank, and Power  icon does not appear on status display.	Power light is off, screen is blank, and Power  icon does not appear on status display.

**The Notebook will not automatically enter Standby or Hibernation mode if using AC power.*

***Important: The Manual Shutdown procedure is not recommended unless the Standard Shutdown is unsuccessful.*

maintenance & service guide

Presario 1800 Series
Models: XL180, XL181, XL182, XL183, XL185,
and XL190, XL191, XL192

Power Settings

Power management levels can be initiated based on the amount of time passed since the last system activity. System activity includes keyboard strokes, mouse movement, CD/DVD playback, or modem use.

Power Schemes

Differing patterns of Notebook use determine the level of power management needed. Power management settings can be selected using several predefined *Power Schemes*. To access these options, select **Power Management** from the **Control Panel**, and then click the **Power Schemes** tab. The default Power Schemes are *Home/Office Desk*, *Portable/Laptop*, and *Always On*. Power Schemes can also be customized by changing the following options:

- **System Standby:** length of inactivity before the Notebook goes into Standby mode.
- **Turn Off Monitor:** length of inactivity before the screen times out and goes blank.
- **Turn Off Hard Disks:** length of inactivity before the hard drive goes into low-power mode.

Important: The setting for the Hard Disk must be less than or equal to the setting for the System. If the Notebook is on a network, Compaq recommends that System Standby be set to Never.

The following table shows the default settings for each Power Scheme.

Power Scheme	AC Power	Battery Power
Always On		
System Standby	Never	5 minutes
Turn OFF Monitor	15 minutes	2 minutes
Turn OFF Hard Disks	1 hour	3 minutes
Portable/Laptop		
System Standby	Never	15 minutes
Turn OFF Monitor	3 hours	Never
Turn OFF Hard Disks	15 minutes	10 minutes
Home/Office Desk		
System Standby	20 minutes	1 minute
Turn OFF Monitor	15 minutes	2 minutes
Turn OFF Hard Disks	30 minutes	10 minutes

maintenance & service guide

Presario 1800 Series
Models: XL180, XL181, XL182, XL183, XL185,
and XL190, XL191, XL192

Alarms

The Notebook can be set to alarm when the battery power level is reduced or when it reaches a critically low level. The Notebook can also be set to enter a low-power mode when the battery reaches a specific power level.

 **CAUTION:** The settings on the Alarms tab are preset for the Notebook to run at its best. Changing any of these settings could cause the Notebook to function improperly. It is recommended that these settings be left at their default values.

Default Alarm Settings		
Setting	Low Battery	Critical Battery
Alarm power level	10%	0%
Notification	Text Message	No Action
Power Mode	No Action	Hibernation

SpeedStep Technology

SpeedStep Technology features several options for processor response to low-power conditions. These include the following settings:

- **Maximum Performance:** always at high speed
- **Battery Optimized:** always at low speed
- **Reversed:** opposite recommended
- **Recommended:** performance on AC, Battery Optimized on Battery
- **Disabled:** no run time support, high speed



SpeedStep options can be accessed in three ways:



- Access **F10** Setup during startup and select the **Advanced** screen.
- Click **Start>Settings>Control Panel>Power Options>Intel(R) SpeedStep^(TM) technology** tab.
- Double-click the Flag icon on the Windows taskbar to open the **Intel(R) SpeedStep^(TM) technology** dialog box.

Presario 1800 Series

Models: **XL180, XL181, XL182, XL183, XL185,**
and **XL190, XL191, XL192**

Rebooting After a Lockup

To reboot the Notebook when the keyboard is frozen or the screen is locked, press and hold down the **Power**  button for at least four seconds; this causes a Manual Shutdown. Then, restart the Notebook with a single press of the **Power**  button.

If the Notebook still does not recover, press the **Power**  button and hold for four seconds to shut it down, and then remove the battery and unplug the AC power for at least 30 seconds. Reinsert the battery or reconnect AC power and press the **Power**  button once to reboot.

Recovering From a Loss of Electrical Power

Loss of electrical power causes the Notebook to turn off automatically. This may cause loss of data because the Microsoft Windows operating system is not able to close all files and programs properly.

Loss of power may be caused by one of the following:

- Electrical power service is interrupted.
- The power cord is accidentally disconnected.

If power surges or sags, the display and status lights may flicker, and the Notebook may automatically restart. If an improper shutdown occurs, ScanDisk, a Microsoft Windows utility program, runs automatically once power is restored. ScanDisk determines if the improper shutdown caused any errors on the hard disk. These errors may occur if the Microsoft Windows operating system is not able to close all files properly before the shutdown. If no errors are found, the restart process continues. If ScanDisk does detect errors, follow the instructions on the screen to continue the restart process. Work that was not saved before the loss of power or shutdown may be lost.

If a power failure occurs, or the power cord disconnects while the Notebook is turned on, turn it off until normal service is restored. The next time the Notebook is turned on, ScanDisk may run to check the hard disk for errors caused by improper shutdown.

maintenance & service guide

Presario 1800 Series

Models: XL180, XL181, XL182, XL183, XL185,
and XL190, XL191, XL192

Increasing Battery-Operating Life

Battery pack operating life is affected by several variables. To avoid unnecessary replacement, consider the following when determining how long a charged battery pack should last:

- Power conservation settings
- Hardware configuration
- Software applications
- Installed options
- Display brightness
- Hard drive usage
- Changes in operating temperature
- Type and number of installed PC Cards

Note: The power consumption requirements for PC Cards vary widely. Some cards drain the battery pack very rapidly.

Battery pack operating time can be increased by as much as 50 percent by controlling the energy required by the Notebook and the energy stored in the battery pack.

Minimizing the Energy Required

To minimize the energy required by the Notebook, follow these steps:

- Set the power conservation levels in the Power Management utility to Maximum.
- Customize the time-out value to work more efficiently with the applications. The amount of battery life depends on the values selected.

Maximizing the Energy Stored

To maximize the energy stored in the battery pack, follow these guidelines:

- [Condition the battery pack](#) at least every 30 days to improve overall battery performance.
- Keep a battery pack in the Notebook when using it with AC power to supply the battery pack with a constant trickle charge.
- Store the battery pack in a cool, dry place when not in use.

maintenance & service guide

Presario 1800 Series

Models: XL180, XL181, XL182, XL183, XL185,
and XL190, XL191, XL192

Conditioning a Battery Pack

 **CAUTION:** To avoid a loss of data, ensure that all information is saved before completely discharging the battery pack.

To condition a battery pack, complete the following steps:

1. Plug in the AC adapter and allow the battery to charge until the fast charge arrow on the status display disappears. The battery gauge may read 100% for a period of time before the arrow disappears.

Note: Do not unplug the AC adapter until the arrow disappears.

2. Unplug the AC adapter and allow the battery to drain until the Notebook enters Hibernation mode. The Notebook can be used normally during this process.

Note: If the AC adapter is connected while the battery is draining, the process must be repeated beginning with step 1.

The battery is now re-conditioned. Plug in the AC adapter and begin using the Notebook.

Disposing of a Used Battery Pack

In the interests of safeguarding our environment, Compaq Computer Corporation recommends that nickel metal hydride (NiMH) and lithium ion (Li-ion) battery packs be recycled. Battery packs should be handled in accordance with country, state, province, or local regulations.

 **CAUTION:** Never attempt to open or service a battery pack. Opening a battery pack not only damages the pack and makes it unusable, it also exposes potentially harmful battery components.

maintenance & service guide

Presario 1800 Series

Models: XL180, XL181, XL182, XL183, XL184, XL185,
and XL190, XL191, XL192

Troubleshooting

This chapter covers troubleshooting and resolving common problems associated with Compaq Presario 1800XL Series Notebook Computers. The basic steps in troubleshooting include:

1. Preparing the Notebook for troubleshooting as outlined in [Preliminary Steps](#)
2. Performing the [Power-On Self Test \(POST\)](#) and observing any error messages displayed

Note: If the Notebook is unable to complete POST or an error message is displayed, skip to Step 3 below to try to resolve the problem.

3. Attempting the recommended solutions described later in this chapter

When following the recommended solutions provided in [POST](#) and [Diagnostic Error Codes](#), perform the steps in the order listed above. Rerun POST after each recommended action until the problem is solved, even if no error message occurs. Once the problem is solved, do not perform the remaining recommended solutions.

Note: If the problem is intermittent, check the Notebook several times to verify that the problem is resolved.

1.800.AT.COMPAQ

maintenance & service guide

Presario 1800 Series

Models: **XL180, XL181, XL182, XL183, XL184, XL185,**
and **XL190, XL191, XL192**

Preliminary Steps

Before running [POST](#), complete the following steps:

1. If a Power-on password is established, type the password and press the **Enter** key. If you do not know the password, clear the password (See [Clearing the Power-On Password](#) later in this chapter).
2. Run [Compaq Diagnostics](#).
3. Turn off the Notebook and its external devices.
4. Disconnect any external devices you do not want to test.

Note: Do not disconnect the printer if you want to test it or use it to log error messages.

Important: If the problem only occurs when an external device is connected to the computer, the problem may be related to the external device or its cable. Verify this by running [POST](#) both with and without the external device connected.

5. Install loopback plugs in the serial and parallel connectors if you would like to test these ports.
6. Ensure that the hard drive is installed in the Notebook.
7. Ensure that the battery pack is installed and the Notebook is connected to an external AC power source.

When these preliminary steps are completed, run [POST](#).

maintenance & service guide

Presario 1800 Series

Models: XL180, XL181, XL182, XL183, XL184, XL185,
and XL190, XL191, XL192

Clearing the Power-On Password

 **CAUTION:** Clearing the Power-on password also removes all setup attributes that are programmed in the CMOS.

If you do not know the Power-on password, clear it by performing the following steps:

1. Turn off the Notebook.
2. Disconnect the power cord.
3. [Remove the battery.](#)
4. [Remove the Palmrest cover.](#)
5. [Remove the keyboard.](#)
6. [Remove the Heatspreader.](#)
7. Locate the CMOS switch to the right of the CD/DVD drive on the system board.
8. Slide the switch to the right  holding it in this position for at least 15 seconds to ensure that the password is cleared.

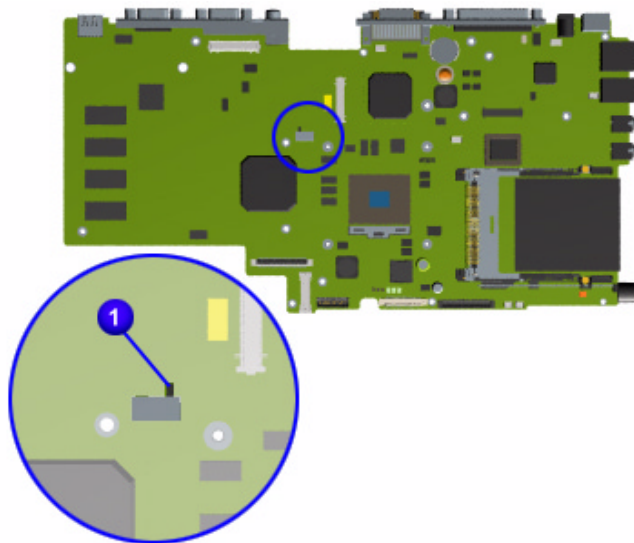

9. Reassemble the Notebook (refer to [Removal and Replacement](#) later in this MSG).
10. Turn on the Notebook to verify that the power-on-password has been cleared. If it has not been cleared, repeat this procedure.

maintenance & service guide

Presario 1800 Series

**Models: XL180, XL181, XL182, XL183, XL184, XL185,
and XL190, XL191, XL192**

Power-On Self Test (POST)

To run POST, complete these steps:

Turn off the Notebook, then turn it on again. As soon as the Compaq logo appears press the **ESC** key to display the POST messages as they occur. Remember any POST error codes that are displayed.

If the Notebook does not beep, POST has successfully completed its test and detected no errors. The Notebook will automatically restart.

Note: If a bootable diskette is installed in the diskette drive, the system will boot from the diskette instead of the hard drive.

However, if POST detects errors, the Notebook will beep and/or display a text message.

Note: If the Notebook is not functioning well enough to complete POST, or the display is unable to show POST error messages, refer to the [solution tables](#) later in this chapter.

POST Error Messages

A list of POST error codes and their descriptions are shown in the tables below.

102-System Board Failure	
Probable Cause	Recommended Action
DMA, timers, and so on	Replace the system board.
162-System Options Not Set	
Probable Cause	Recommended Action
Incorrect configuration	Run Setup.
CMOS reflects an invalid configuration setting.	Run Setup.
RAM failure	1. Replace the memory modules. 2. Replace the system board.
Memory test data error	1. Replace the memory modules. 2. Replace the system board.
XX000YZZ RAM failure	Replace the system board.

maintenance & service guide

Presario 1800 Series

Models: XL180, XL181, XL182, XL183, XL184, XL185,
and XL190, XL191, XL192

XX000YZZ 201-Memory Error

Probable Cause	Recommended Action
Memory failure	<ol style="list-style-type: none"> 1. Replace the memory modules. 2. Replace the system board.

301-Keyboard Error

Probable Cause	Recommended Action
Keyboard failure	<ol style="list-style-type: none"> 1. Ensure the keys are not depressed during POST. 2. Reconnect the keyboard with the Notebook off. 3. Replace the keyboard.

304-Keyboard or System Unit Error

Probable Cause	Recommended Action
Keyboard or system board error	<ol style="list-style-type: none"> 1. Replace the keyboard. 2. Replace the TouchPad. 3. Replace the system board.

601-Diskette Controller Error

Probable Cause	Recommended Action
Mismatch in drive type or failure in the diskette controller	<ol style="list-style-type: none"> 1. Run Checkup (TEST). 2. Check or replace cables. 3. Replace the system board.

605-Diskette Drive Error

Probable Cause	Recommended Action
Mismatch in drive type	Run Setup.

1780-Primary Hard Drive 0 Failure

Probable Cause	Recommended Action
Disk 0 failed to respond	<ol style="list-style-type: none"> 1. Run Checkup (TEST). 2. Replace the hard drive.
Hard drive format error	<ol style="list-style-type: none"> 1. Run Checkup (TEST). 2. Replace the hard drive.

maintenance & service guide

Presario 1800 Series

Models: XL180, XL181, XL182, XL183, XL184, XL185,
and XL190, XL191, XL192

1782-Hard Drive Controller

Probable Cause	Recommended Action
Hard drive controller failure	1. Run Setup. 2. Replace the hard drive.

Compaq Diagnostics

Compaq Diagnostics utilities come pre-installed on 1800XL Series Notebook. Run the Diagnostic utilities to view or test system information and external devices. If Compaq Diagnostics is run from a diskette, ensure that the diagnostic program is version 10.11 or later.

The Diagnostics menu includes the following utilities:

- [Checkup \(TEST\)](#)
- [View System Information \(INSPECT\)](#)
- Prepare Notebook for a Compaq Service Call (RemotePaq)

Customers are encouraged to run the Diagnostics utilities to try to solve a problem before calling for support. [Checkup \(TEST\)](#) should be run with the options for saving the device list to a file and printing or saving the error log. The [View System Information \(INSPECT\)](#) utility should also be run with the option for printing or saving the information. Customers should have these files or the printed information available when calling for support.

maintenance & service guide

Presario 1800 Series

Models: XL180, XL181, XL182, XL183, XL184, XL185,
and XL190, XL191, XL192

Checkup (TEST)

Checkup is included on the *Compaq Diagnostics Diskette*. Checkup determines if the various Notebook components and devices are recognized by the system and are functioning properly. You can display, print, or save the information generated by Checkup.

Follow these steps to run Checkup:

1. Plug the Notebook into an external power source. (A low-battery condition could interrupt the program.)
2. Turn on the external devices you want to test. Connect the printer if you want to print a log of error messages.
3. Insert the *Compaq Diagnostics Diskette* in the diskette drive.
4. Turn on or restart the Notebook. The Notebook boots from the diskette, and after a few seconds, the diagnostics Welcome screen is displayed.
5. Press **Enter** to continue. The Diagnostics menu is displayed.
6. Select **Computer Checkup** from the **Diagnostics** menu. The Test Option menu is displayed.
7. Select **View the Device List** from the **Test Option** menu. A list of installed Compaq devices is displayed.
8. If the list of installed devices is correct, select **OK**. The Test Option menu is displayed.

Note: If the list is incorrect, ensure that any new devices are installed properly and run Checkup again.

9. Select one of the following from the **Test Option** menu:
 - **Quick Check Diagnostics.** Runs a quick, general test on each device with a minimal number of prompts. If errors occur, they display when the testing is complete. You cannot print or save the error messages.
 - **Automatic Diagnostics.** Runs unattended, maximum testing of each device with minimal prompts. You can choose how many times to run the tests, to stop on errors, or to print or save a log of errors.
 - **Prompted Diagnostics.** Allows maximum control over testing the devices. You can choose attended or unattended testing, decide to stop on errors, or choose to print or save a log of errors.

maintenance & service guide

Presario 1800 Series

Models: XL180, XL181, XL182, XL183, XL184, XL185,
and XL190, XL191, XL192

10. Follow the on-screen instructions as the devices are tested. When testing is complete, the Test Option menu is displayed.
11. Exit the Test Option and Diagnostics menus.

View System Information (INSPECT)

The INSPECT utility provides information about the Notebook and installed or connected devices. You can display, print, or save the information.

Follow these steps to run INSPECT from the *Compaq Diagnostics Diskette*:

1. Turn on any external devices you want to test. Connect the printer if you want to print the information.
2. Insert the *Compaq Diagnostics Diskette* in the diskette drive.
3. Turn on or restart the Notebook. The Notebook boots from the diskette, and after a few seconds, the diagnostics Welcome screen is displayed.
4. Press **Enter** to continue. The Diagnostics menu is displayed.
5. Select **View System Information (INSPECT)** from the **Diagnostics** menu.
6. Select the item you want to view from the following list:

System	Memory
ROM	Audio
Keyboard	Operating system
System ports	System files
System storage	Windows files
Graphics	

7. Follow the on-screen instructions to cycle through the screens, return to the list and choose another item, or print the information.

maintenance & service guide

Presario 1800 Series

Models: XL180, XL181, XL182, XL183, XL184, XL185,
and XL190, XL191, XL192

Diagnostic Error Codes

Diagnostic error codes are displayed if the system recognizes a problem while running the [Compaq Diagnostics](#) program. These error codes help identify subassemblies that may be damaged or defective.

The following tables list error codes, a description of the error condition, and the action required to resolve the error condition.

Important: Retest the system after completing each step. If the problem is resolved, do not attempt the remaining steps.

Note: Some of the solutions provided in this chapter involve replacing Notebook components. Refer to the specific [Removal and Replacement](#) procedures for each component.

Select error codes by number or type:

- 101 - 114: Processor Test ([pg 10](#))
- 200 - 215: Memory Test ([pg 10](#))
- 300 - 304: Keyboard Test ([pg 11](#))
- 401 - 403: Parallel Printer Test ([pg 11](#))
- 501 - 516: Video Test ([pg 14](#))
- 600 - 699: Diskette Drive Test ([pg 12](#))
- 1101: Serial Test ([pg 12](#))
- 1701 - 1736: Hard Drive Test ([pg 13](#))
- 2402 - 2418: Video Test ([pg 15](#))
- 2419 - 2456: Video Test ([pg 16](#))
- 2458 - 2480: Video Test ([pg 16](#))
- 3206: Audio Test ([pg 17](#))
- 3301 - 6623: DVD or CD Test ([pg 17](#))
- 8601 - 8602: TouchPad Test ([pg 17](#))

maintenance & service guide

Presario 1800 Series

**Models: XL180, XL181, XL182, XL183, XL184, XL185,
and XL190, XL191, XL192**

Processor Test Error Codes		
Error Code	Description	Recommended Action
101-xx	CPU test failed	Replace the processor and retest.
102-xx	Coprocessor or Weitek Error	1. Run the Configuration and Diagnostics utilities. 2. Replace the processor and retest.
103-xx	DMA page registers test failed	Replace the system board and retest.
104-xx	Interrupt controller master test failed	
105-xx	Port 61 error	
106-xx	Keyboard controller self-test failed	
107-xx	CMOS RAM test failed	
108-xx	CMOS interrupt test failed	
109-xx	CMOS clock test failed	
110-xx	Programmable timer load data test failed	
113-xx	Protected mode test failed	
114-01	Speaker test failed	1. Check system configuration. 2. Verify cable connections to speakers. 3. Replace the system board and retest.

Memory Test Error Codes		
Error Code	Description	Recommended Action
200-xx	Memory machine ID test failed	1. Flash the system ROM and retest.
202-xx	Memory system ROM checksum failed	2. Replace the system board and retest.
203-xx	Write/Read test failed	1. Remove the memory module and retest.
204-xx	Address test failed	2. Install a new memory module and retest.
211-xx	Random pattern test failed	
214-xx	Noise test failed	
215-xx	Random address test failed	

maintenance & service guide

Presario 1800 Series

Models: XL180, XL181, XL182, XL183, XL184, XL185,
and XL190, XL191, XL192

Keyboard Test Error Codes

Error Code	Description	Recommended Action
300-xx	Failed ID Test	1. Check the keyboard connection. If disconnected, turn off the Notebook and reconnect the keyboard. 2. Replace the keyboard and retest. 3. Replace the system board and retest.
301-xx	Failed Self-Test/Interface Test	
302-xx	Failed Individual Key Test	
304-xx	Failed Keyboard Repeat Test	

Parallel Printer Test Error Codes

Error Code	Description	Recommended Action
401-xx	Printer failed or not connected	1. Connect the printer. 2. Check power to the printer. 3. Install loopback connector on printer port and retest. 4. Check port and IRQ configuration. 5. Replace the system board and retest.
402-xx	Failed Port Test	
403-xx	Printer pattern test failed	

maintenance & service guide

Presario 1800 Series

Models: XL180, XL181, XL182, XL183, XL184, XL185,
and XL190, XL191, XL192

Diskette Drive Test Error Codes

Error Code	Description	Recommended Action
600-xx	Diskette ID drive types test failed	1. Replace the diskette media and retest.
601-xx	Diskette format failed	2. Check and/or replace the diskette drive cables and retest.
602-xx	Diskette read test failed	3. Replace the diskette drive and retest.
603-xx	Diskette write, read, compare test failed	4. Replace the system board and retest.
604-xx	Diskette random read test failed	
605-xx	Diskette ID media failed	
606-xx	Diskette speed test failed	
609-xx	Diskette reset controller test failed	
610-xx	Diskette change line test	
697-xx	Diskette type error	
698-xx	Diskette drive speed not within limits	
699-xx	Diskette drive/media ID error	1. Replace diskette media and retest. 2. Run the Configuration and Diagnostics utilities.

Serial Test Error Codes

Error Code	Description	Recommended Action
1101-xx	Serial port test failed	1. Check port configuration. 2. Replace the system board and retest.

maintenance & service guide

Presario 1800 Series

**Models: XL180, XL181, XL182, XL183, XL184, XL185,
and XL190, XL191, XL192**

Hard Drive Test Error Codes		
Error Code	Description	Recommended Action
1701-xx	Hard drive format test failed	<ol style="list-style-type: none"> 1. Run the Configuration and Diagnostics utilities and verify drive type. 2. Verify that all secondary drives have secondary drive capability. 3. Replace the hard drive and retest. 4. Replace the system board and retest.
1702-xx	Hard drive read test failed	
1703-xx	Hard drive write/read/compare test failed	
1704-xx	Hard drive random seek test failed	
1705-xx	Hard drive controller test failed	
1706-xx	Hard drive ready test failed	
1707-xx	Hard drive recalibration test failed	
1708-xx	Hard drive format bad track test failed	
1709-xx	Hard drive reset controller test failed	
1710-xx	Hard drive park head test failed	
1715-xx	Hard drive head select test failed	
1716-xx	Hard drive conditional format test failed	
1717-xx	Hard drive ECC* test failed	
1719-xx	Hard drive power mode test failed	
1724-xx	Network preparation test failed	
1736-xx	Drive monitoring test failed	

**ECC = Error Correction Code*

maintenance & service guide

Presario 1800 Series

Models: XL180, XL181, XL182, XL183, XL184, XL185,
and XL190, XL191, XL192

Video Test Error Codes		
Error Code	Description	Recommended Action
501-xx	Video controller test failed	1. Disconnect external monitor and test with the Notebook display. 2. Replace the display assembly and retest. 3. Replace the system board and retest.
502-xx	Video memory test failed	
503-xx	Video attribute test failed	
504-xx	Video character set test failed	
505-xx	Video 80 x 25 mode 9 x 14 character cell test failed	
506-xx	Video 80 x 25 mode 8 x 8 character cell test failed	
507-xx	Video 40 x 25 mode test failed	
508-xx	Video 320 x 200 mode color set 0 test failed	
509-xx	Video 320 x 200 mode color set 1 test failed	
510-xx	Video 640 x 200 mode test failed	
511-xx	Video screen memory page test failed	
512-xx	Video gray scale test failed	
514-xx	Video white screen test failed	
516-xx	Video noise pattern test failed	

maintenance & service guide

Presario 1800 Series

Models: XL180, XL181, XL182, XL183, XL184, XL185,
and XL190, XL191, XL192

Video Test Error Codes (Continued)

Error Code	Description	Recommended Action
2402-xx	Video memory test failed	<ol style="list-style-type: none">1. Run the Configuration and Diagnostics utilities.2. Replace the display assembly and retest.3. Replace the system board and retest.
2403-xx	Video attribute test failed	
2404-xx	Video character set test failed	
2405-xx	Video 80 x 25 mode 9 x 14 character cell test failed	
2406-xx	Video 80 x 25 mode 8 x 8 character cell test failed	
2408-xx	Video 320 x 200 mode color set 0 test failed	
2409-xx	Video 320 x 200 mode color set 1 test failed	
2410-xx	Video 640 x 200 mode test failed	
2411-xx	Video screen memory page test failed	
2412-xx	Video gray scale test failed	
2414-xx	Video white screen test failed	
2416-xx	Video noise pattern test failed	
2418-xx	ECG/VGC memory test failed	

maintenance & service guide

Presario 1800 Series

**Models: XL180, XL181, XL182, XL183, XL184, XL185,
and XL190, XL191, XL192**

Video Test Error Codes (Continued)			
Error Code	Description	Recommended Action	
2419-xx	ECG/VGC ROM checksum test failed	<ol style="list-style-type: none"> 1. Run the Configuration and Diagnostics utilities. 2. Disconnect external monitor and test with the Notebook display. 3. Replace the display assembly and retest. 4. Replace the system board and retest. 	
2421-xx	ECG/VGC 640 x 200 graphics mode test failed		
2422-xx	ECG/VGC 640 x 350 16 color set test failed		
2423-xx	ECG/VGC 640 x 350 64 color set test failed		
2424-xx	ECG/VGC monochrome text mode test failed		
2425-xx	ECG/VGC monochrome graphics mode test failed		
2431-xx	640 x 480 graphics test failure		
2432-xx	320 x 200 graphics (256 color mode) test failure		
2448-xx	Advanced VGA Controller test failed		
2451-xx	132-column Advanced VGA test failed		
2456-xx	Advanced VGA 256 Color test failed		
2458-xx	Advanced VGA BitBLT test failed		Replace the system board and retest.
2468-xx	Advanced VGA DAC test failed		
2477-xx	Advanced VGA data path test failed		
2478-xx	Advanced VGA BitBLT test failed		
2480-xx	Advanced VGA LineDraw test failed		

maintenance & service guide

Presario 1800 Series

Models: XL180, XL181, XL182, XL183, XL184, XL185,
and XL190, XL191, XL192

Audio Test Error Codes

Error Code	Description	Recommended Action
3206-xx	Audio System Internal Error	Replace the system board and retest.

TouchPad Interface Test Error Codes

Error Code	Description	Recommended Action
8601-xx	Mouse test failed	1. Replace the TouchPad and retest.
8602-xx	Interface test failed	2. Replace the system board and retest.

DVD or CD Drive Test Error Codes

Error Code	Description	Recommended Action
3301-xx	DVD or CD drive read test failed	1. Replace the DVD or CD media and retest.
3305-xx	DVD or CD drive seek test failed	2. Verify that the speakers are connected.
6600-xx	ID test failed	3. Verify that drivers are loaded and properly installed.
6605-xx	Read test failed	4. Replace the CD/DVD drive and retest.
6608-xx	Controller test failed	5. Replace the system board and retest.
6623-xx	Random read test failed	

maintenance & service guide

Presario 1800 Series

Models: XL180, XL181, XL182, XL183, XL184, XL185,
and XL190, XL191, XL192

Troubleshooting without Diagnostics

This section provides information about how to identify and correct some common hardware, memory, and software problems. It also explains several types of common messages that may be displayed on the screen. The following pages contain troubleshooting information regarding:

[Audio](#)

[Battery](#)

[CD or DVD Drive](#)

[Diskette Drive](#)

[Display](#)

[Hard Drive](#)

[Hardware Installation](#)

[Memory](#)

[PC Card](#)

[Power](#)

[Printer](#)

[TouchPad](#)

[Keyboard/Numeric Keypad](#)

Carefully match the symptoms against the problem described in the tables to avoid a misdiagnosis.



WARNING: To avoid a potential shock hazard during troubleshooting procedures, disconnect all power sources before removing the keyboard cover or the display bezel.

Before Replacing Parts

- Verify that all cables are properly connected to the parts that are to be tested.
- Run Setup after connecting external devices.
- Verify that all required device drivers are installed.
- Verify that all required changes have been made to the CONFIG.SYS file.
- Verify that all required changes have been made to the AUTOEXEC.BAT file.
- Verify that all printer drivers have been installed for each application.

maintenance & service guide

Presario 1800 Series

Models: XL180, XL181, XL182, XL183, XL184, XL185,
and XL190, XL191, XL192

Solving Minor Problems

Some problems and possible solutions are outlined in the following tables. If the problem appears related to a software application, check the documentation provided with the software.

Audio Solutions

Common audio problems and solutions are listed in the following table.

Audio		
Problem	Probable Cause	Solution
Notebook does not beep after the Power-On Self-Test (POST).	This is typical; it indicates successful completion of the Power-On Self-Test (POST).	No action is required.

Battery Pack/Gauge Solutions

Some causes and solutions for common battery pack problems are listed in the following table. [Power Solutions](#) later in this chapter may also be applicable to the following problems.

Battery Pack/Gauge		
Problem	Probable Cause	Solution(s)
Notebook won't turn on when battery pack is inserted and power cord is unplugged.	Battery pack is discharged.	<ul style="list-style-type: none"> • Connect the Notebook to an external power source and charge the battery pack. <p>OR</p> <ul style="list-style-type: none"> • Replace the battery pack with a fully charged battery pack. <p>Check the battery connectors on the system board to verify that they are evenly spaced and not bent or broken.</p>

maintenance & service guide

Presario 1800 Series

**Models: XL180, XL181, XL182, XL183, XL184, XL185,
and XL190, XL191, XL192**

Battery Pack/Gauge		
Problem	Probable Cause	Solution(s)
Notebook is beeping and battery icon is blinking.	Battery charge is low.	Immediately save any open file(s). Then complete one of the following steps: <ul style="list-style-type: none"> • Connect the Notebook to an external power source to charge the battery pack. • Turn off the Notebook or initiate Hibernation until you can find another power source or charge the battery pack.
Battery icon on the front of the unit blinks to indicate low-battery condition, but Notebook does not beep.	Volume is turned down too low.	Adjust the volume.
Battery icon doesn't light and battery pack won't fast charge.	Battery pack is already charged.	No action is necessary.
	Battery pack was exposed to temperature extremes.	Allow time for the battery pack to return to room temperature.
	Battery pack is at the end of its life.	Replace the battery pack.
You have to set the date and time every time you turn on the Notebook.	RTC battery is dead.	Replace the RTC battery.
Battery charge does not last as long as expected.	Battery is exposed to high or extremely cold temperatures.	Keep the battery pack within the recommended temperature range for operation or storage. <ul style="list-style-type: none"> • Operating Range: 50°F to 104°F (10°C to 40°C) • Storage Range: -4°F to 86°F (-20°C to 30°C) Recharge the battery pack.
	Battery has partially self-discharged.	Recharge the battery. Discharge the battery completely and then recharge it.

maintenance & service guide

Presario 1800 Series

**Models: XL180, XL181, XL182, XL183, XL184, XL185,
and XL190, XL191, XL192**

Battery Pack/Gauge		
Problem	Probable Cause	Solution(s)
Battery charge does not last as long as expected.	Power management is disabled.	Set a power management level in Setup.
	An external device or PC Card is draining the battery.	Turn off or disconnect external devices when not in use.
Battery pack is warm to the touch after charging.	Normal warming has occurred due to charging.	No action is required.
	Power management is turned off or disabled.	Enable power management in Setup and in Windows Power Properties.
Battery pack operating time is far less than the documented average operating time.	An external device or PC Card is draining the battery.	Turn off or disconnect external devices when not in use.
	Battery pack has partially self-discharged.	Condition the battery pack by fully charging, fully discharging, then fully recharging it. To maintain the charge, leave battery packs in the Notebook when it is connected to external power. If the Notebook is disconnected from external power for more than two weeks, remove battery packs from the Notebook to reduce the discharge rate.
Battery pack is exposed to high or extremely cold temperatures.	Battery pack is exposed to high or extremely cold temperatures.	Keep the battery pack within the recommended temperature range for operation or storage. <ul style="list-style-type: none"> • Operating Range: 50°F to 104°F (10°C to 40°C) • Storage Range: -4°F to 86°F (-20°C to 30°C) Recharge the battery pack.

maintenance & service guide

Presario 1800 Series

Models: **XL180, XL181, XL182, XL183, XL184, XL185,**
and **XL190, XL191, XL192**

CD and DVD Drive Solutions

Some causes and solutions for CD and DVD drive problems are listed in the following table.

CD or DVD Drive		
Problem	Probable Cause	Solution(s)
CD or DVD drive cannot read a Compact Disc or Digital Versatile Disc.	Disc is upside down or is improperly inserted in the CD or DVD drive.	Open the loading tray, lay the compact disc in it (label side up), then close the tray.
	CD is CD Plus or Pregap/Track 0 type.	Cannot read these types CDs in 24x. Remove the CD.

Diskette Drive Solutions

Some causes and solutions for diskette drive problems are listed in the following table.

Diskette Drive		
Problem	Probable Cause	Solution(s)
Diskette drive cannot write to a diskette.	Diskette is write-protected.	Disable the diskette's write-protect feature or use a diskette that is not write-protected.
	Computer is writing to the wrong drive.	Check the drive letter in the path statement.
	Not enough space is left on the diskette.	Use another diskette.
	Drive error has occurred.	Run Checkup from the Compaq Diagnostics diskette.
Diskette drive cannot read a diskette.	Diskette is not formatted.	Format the diskette. At the system prompt, enter FORMAT A:
	The wrong type of diskette is being used.	Use the type of diskette required by the drive.
	Diskette has a bad sector.	Copy files to hard drive or another diskette. Reformat bad diskette.
	Drive error has occurred.	Run Checkup from the Compaq Diagnostics diskette.

maintenance & service guide

Presario 1800 Series

Models: **XL180, XL181, XL182, XL183, XL184, XL185,**
and **XL190, XL191, XL192**

Diskette Drive		
Problem	Probable Cause	Solution(s)
Diskette drive cannot read a diskette.	Diskette is not formatted.	Format the diskette. At the system prompt, enter FORMAT A:
Cannot boot from diskette.	Bootable diskette is not in the diskette drive.	Put the bootable diskette in the diskette drive.
	Diskette Boot has incorrect setting in Setup.	Run Setup and set diskette as first to boot.

Display Solutions

This section lists some causes and solutions for common Notebook display and external monitor problems.

You can perform a monitor self-test on an external VGA color or monochrome monitor by completing the following steps:

1. Turn off the monitor.
2. Turn off the Notebook.
3. Disconnect the monitor signal cable from the Notebook.
4. Turn on the monitor and allow it to warm up for one minute.

The display should be white. A narrow black border may also appear on the left and right sides of the display. Either of these displays indicates that the monitor is working properly.

Display		
Problem	Probable Cause	Solution(s)
Screen is dim.	Brightness control (if applicable) is not set properly.	Adjust the brightness of the display by using Fn+F7 or Fn+F8 .
Screen is blank.	The Notebook display is in direct light.	Tilt display or move Notebook.
	Screen save was initiated by Power Properties due to lack of user activity.	Press any key or touch the TouchPad.
	Display has overheated.	If the Notebook is in direct sunlight, move it and allow it to cool off.

maintenance & service guide

Presario 1800 Series

**Models: XL180, XL181, XL182, XL183, XL184, XL185,
and XL190, XL191, XL192**

Display		
Problem	Probable Cause	Solution(s)
Display is blank and the Standby icon is flashing.	System is in Standby mode.	Press any key or touch the TouchPad.
Notebook display is blank and the screen on an external monitor displays information.	Display function was switched to the external monitor.	Press Fn+F3 to switch between the external monitor and the Notebook display (you may have to press more than once).
Notebook display flashes or has garbled characters when Notebook is connected to external monitor.	The external monitor is set for 1024 x 768 or higher resolution and view is toggled back to the Notebook display, which supports up to 800 x 600.	Restart the Notebook.
The light tubes on the edge of the display panel do not light up at all and the Power-On Self-Test (POST) completes when the unit is powered up.**	Improper backlight or display cable connections.	1. Check the display cable connections and retest. 2. Replace the display assembly.
	Defective inverter board.	Replace the display assembly.
	Defective display cable.	Replace the display assembly.
	Defective display panel.	Replace the display assembly.
	Defective system board.	Replace the system board.
The light tubes on the edge of the display panel do not light up at all and Power-On Self-Test (POST) does not complete when the unit is powered up.**	Defective system board.	Replace the system board.

***This problem indicates that the backlight or its power circuitry has failed. If the backlight is not functioning, the POST result cannot be observed. Connect the unit to an external monitor before powering up the unit. If an external monitor is not available verify that POST is complete by opening and closing the display, listening for the single or double beep, and watching for the icons to turn on at the front of the Notebook.*

maintenance & service guide

Presario 1800 Series

**Models: XL180, XL181, XL182, XL183, XL184, XL185,
and XL190, XL191, XL192**

Display (Continued)		
Problem	Probable Cause	Solution(s)
Backlight (brightness) cannot be adjusted with Fn+F7 or Fn+F8.	Improper display cable connections.	1. Reseat the display cable to the system board. 2. Replace the display assembly.
	Defective inverter board.	Replace the display assembly.
	Defective display cable.	Replace the display assembly.
This display panel has a continuous pattern across it (e.g., "jailbars" pattern), has a single color on it, or has garbled graphics across the entire panel. This failure is for patterns across the entire panel (not just on one section).	Defective system board.	Replace the system board.
	Improper display cable connections.	Reseat the display cable to the following until the problem is solved: 1. System board 2. Display assembly
	Defective display cable.	Replace the display assembly.
A single line, small group of lines, or block appears on the display panel. This failure occurs in only a section of the display panel.	Defective inverter board.	Replace the display assembly.
	Defective system board.	Replace the system board.
	Defective display panel.	Replace the display assembly.

Note: When you perform a "self-test" on an external VGA color or monochrome monitor, the screen should be white. A narrow black border may also appear on the left and right sides of the display. Either of these displays indicates that the monitor is working properly.

maintenance & service guide

Presario 1800 Series

**Models: XL180, XL181, XL182, XL183, XL184, XL185,
and XL190, XL191, XL192**

Hard Drive Solutions

Some causes and solutions for hard drive problems are listed in the following table.

CAUTION: To prevent loss of information, maintain an up-to-date backup of your hard drive in case of errors or failures.

Hard Drive		
Problem	Probable Cause	Solution(s)
Reading hard drive takes an unusually long time after restarting the Notebook.	System entered Hibernation due to low-battery condition and is now exiting from it.	Give the system time to restore the previously saved data to its exact state before Hibernation.
Hard drive error occurs.	Hard drive has bad sectors or has failed.	Run Checkup (TEST) .
Hard drive does not work.	Hard drive is not seated properly.	Turn off and unplug the Notebook, remove the battery pack , and remove and then reinstall the hard drive .

Hardware Installation Solutions

The possible cause and some solutions for a hardware installation problem are listed in the following table.

Hardware Installation		
Problem	Probable Cause	Solution(s)
A new device is not recognized as part of the system.	Cable(s) of new external device are loose or power cables are unplugged.	Ensure that all cables are properly and securely connected.
	Power switch of new external device is not turned on.	Turn off the Notebook, turn on the external device, then turn on the Notebook to integrate the device with the system.
	Device is not seated properly.	Turn off the Notebook and reinsert the device.

maintenance & service guide

Presario 1800 Series

**Models: XL180, XL181, XL182, XL183, XL184, XL185,
and XL190, XL191, XL192**

Keyboard/Numeric Keypad Solutions

Some causes and solutions for keyboard/numeric keypad problems are listed in the following table.

Keyboard/Numeric Keypad		
Problem	Probable Cause	Solution(s)
Embedded numeric keypad on Notebook keyboard is disabled.	Num Lock function is not enabled.	Press the Shift+NumLk keys to enable the Num Lock function and embedded numeric keypad. The Num Lock icon appears on the status display.
Embedded numeric keypad is disabled and Num Lock function is on.	External numeric keypad is connected to the Notebook.	Disconnect the external numeric keypad from the Notebook.

Memory Solutions

Some causes and solutions for memory problems are listed in the following table.

Memory		
Problem	Probable Cause	Solution(s)
Memory count during Power-On Self-Test (POST) is incorrect.	Optional memory expansion card is installed incorrectly, is incompatible with the Notebook, or is defective.	Ensure that the optional memory expansion card is installed correctly, and then restart the Notebook.
"Out of Memory" message is displayed on the screen or insufficient memory error occurs during operation.	System ran out of memory for the application.	Check the application documentation for memory requirements. If necessary, install additional memory.
	Too many TSR (terminate-and-stay-resident) applications are running.	Remove from memory any TSR applications you do not need.

maintenance & service guide

Presario 1800 Series
Models: XL180, XL181, XL182, XL183, XL184, XL185,
and XL190, XL191, XL192

PC Card Solutions

The following table lists some causes and solutions for PC Card problems.

PC Card		
Problem	Probable Cause	Solution(s)
When turned on, the Notebook does not beep when a PC Card is inserted.	Card is not inserted properly.	Make sure that the card is inserted properly.
	PC Card beeps are disabled.	Double-click the PC Card icon in Control Panel, click the Global Settings tab, and enable PC Card sound effects .
	Speaker is turned off or volume is turned down.	Press Volume buttons to turn the speaker on and then increase the volume.
PC Card modem, fax, or network card does not work.	PC Card drivers are not installed.	Double-click the Add New Hardware icon in the Control Panel for installation instructions. If PC Card or drivers are not compatible with Windows, install drivers and use the PC Card in MS-DOS mode.
	Card or card driver is not supported.	Contact a Compaq authorized Service Provider for a list of PC Cards tested successfully in Compaq platforms.
PC Card modem, fax, or network card does not work.	Card is not fully inserted into the slot or is not inserted properly.	Ensure that the card is inserted in the slot in the correct orientation.
	Telephone cord is not plugged in all the way.	Check and secure telephone connection.
PC Card modem or fax card does not work.	Necessary drivers are not installed (enabled).	Install drivers.
	You are trying to access the card using the wrong COM port.	See the Specifications chapter to verify the correct COM port.
	The card conflicts with a serial device.	See the Specifications chapter to verify the correct address.

maintenance & service guide

Presario 1800 Series

Models: XL180, XL181, XL182, XL183, XL184, XL185,
and XL190, XL191, XL192

PC Card		
Problem	Probable Cause	Solution(s)
PC Card modem or fax card does not work.	The card is not supported.	Use supported cards only.
Modem network PC Card does not work.	Network driver is not installed or is not set up properly.	Install driver.
	Telephone cord is not properly connected.	Verify telephone connection.
Memory or storage PC Card does not work.	SRAM and flash memory cards require the memory card driver (loaded and enabled). Flash memory cards require the Microsoft FlashFile System. Hard drives on flash mass storage cards require the PC Card ATA driver.	Install driver(s).
	You are trying to access the hard drive card using the wrong drive letter.	Double-click My Computer to verify the drive letter assigned to the card.
	The card is not supported.	Contact a Compaq authorized Service Provider for a list of PC Cards tested successfully in Compaq platforms.

maintenance & service guide

Presario 1800 Series

Models: **XL180, XL181, XL182, XL183, XL184, XL185,**
and **XL190, XL191, XL192**

Power Solutions

Some causes and solutions for power problems are listed in the following table. See also [Battery Pack/Gauge Solutions](#) in this chapter.

Power		
Problem	Probable Cause	Solution(s)
Notebook will not turn on and the battery pack is not inserted.	Notebook is not connected to a power source.	Insert battery or connect an external power source.
	Power cords to the external power source are unplugged.	Ensure that power cords connecting the Notebook and the external power source are plugged in properly.
	Power adapter is defective.	Replace AC Adapter and restart.
Notebook turned off while it was left unattended and the Power icon is off.	System initiated Hibernation after a preset timeout.	Turn on the Notebook.
	System initiated Hibernation due to a critical low-battery condition.	Replace the battery pack with a fully charged battery pack, or connect the Notebook to an external power source. Then turn on the Notebook.
	System board is defective.	Replace the system board.

maintenance & service guide

Presario 1800 Series

**Models: XL180, XL181, XL182, XL183, XL184, XL185,
and XL190, XL191, XL192**

Printer Solutions

If you experience problems printing, run a printer self-test. Refer to the documentation provided with the printer for instructions. If the self-test fails, the problem is associated with the printer, not the Notebook. To diagnose other printing problems, refer to the printing section of the application documentation.

Printer		
Problem	Probable Cause	Solution(s)
Printer will not turn on.	The signal cable may not be connected properly, or the printer is unplugged.	Make sure that the signal cable is properly connected and that the power cord is connected to the electrical outlet.
Printer will not print.	Printer is not turned on or is offline.	Turn the printer on and set it to online.
	Paper tray is empty.	Fill the paper tray with paper and set the printer to online.
	The device drivers for the application are not installed.	Refer to the printer documentation to install the correct printer driver.
Printer prints garbled information.	Printer is set up for a network, but is not connected to the network.	Connect the printer to the network.
	Printer cable is too long, unshielded, or defective.	Replace the cable.
	Correct printer drivers are not installed.	Refer to the printer documentation to install the correct printer driver.
	Cable is not connected properly.	Make sure that the printer signal cable is properly connected to the Notebook.
	Cable is defective.	Replace the printer cable and retest.

maintenance & service guide

Presario 1800 Series
Models: XL180, XL181, XL182, XL183, XL184, XL185,
and XL190, XL191, XL192

TouchPad/Pointing Device Solutions

The following table lists some causes and solutions for TouchPad/pointing device problems.

TouchPad/Pointing Device		
Problem	Probable Cause	Solution(s)
TouchPad or mouse does not work.	Incorrect or no device driver is installed.	Install the device driver and add to the AUTOEXEC.BAT file or CONFIG.SYS file.
	The device driver is not installed in Windows.	Install the TouchPad/mouse driver in Windows.
External mouse does not work.	Mouse is not securely connected or is connected to an incorrect external connector.	Ensure that the mouse is securely connected to the appropriate external connector.
	Mouse is not enabled.	Enter mouse at the system prompt to activate the mouse device driver. Add a line in the AUTOEXEC.BAT file to automatically activate the mouse driver each time the computer is turned on or restarted.
TouchPad or mouse does not work even though the device is enabled in Windows.	Cable is not properly seated on TouchPad board.	Reseat cable.
	Defective TouchPad board.	Replace the TouchPad board.
	Defective system board.	Replace system board.
Cursor skips or moves abnormally when using the TouchPad.	Device driver is not correctly installed in Windows.	Install the appropriate device driver in Windows.
	The TouchPad needs to be cleaned.	Clean the TouchPad with a cloth dampened with alcohol or an ammonia-based glass cleaner. Wipe up liquid with a dry cloth.

maintenance & service guide

Presario 1800 Series

Models: XL180, XL181, XL182, XL183, XL184, XL185,
and XL190, XL191, XL192

Contacting Compaq Support

Customers should provide the following information when contacting Compaq Reseller Support:

- Product name
- Product serial number
- Purchase date
- Conditions under which the problem occurred
- Any error messages that have occurred
- Hardware configuration
- Type of printer connected
- Hardware/software installed
- Printed result of [Checkup \(TEST\)](#)
- Printed copies of CONFIG.SYS and AUTOEXEC.BAT files, if possible.

Shipping Preparation

Before shipping the Notebook, complete the following steps:

1. Back up the critical hard drive files. Ensure that backup tapes/diskettes are not exposed to electrical or magnetic fields while stored or in transit.
2. Turn off the Notebook and all external devices.
3. Disconnect the external devices from their power sources, then from the Notebook.

Important: Make sure that there is no diskette in the diskette drive and that there are no PC cards in the PC slots.

4. Close the display and all exterior doors of the Notebook.
5. Pack the Notebook with sufficient packing material to protect it. Use the original packing box or similar packaging.

maintenance & service guide

Presario 1800 Series
Models: XL180, XL181, XL182, XL183, XL185,
and XL190, XL191, XL192

Removal and Replacement

This chapter details removing and replacing each component of the Presario 1800XL Notebook Computers.

Electrostatic Discharge

When removing or replacing parts, be careful to discharge static electricity before touching the Notebook's internal components. A sudden discharge of static electricity from a finger or other conductor can destroy static-sensitive devices and microcircuitry. Often the spark is neither felt nor heard, but damage occurs. An electronic device exposed to an electrostatic discharge may not seem affected and work perfectly throughout a normal cycle. However, the discharge degrades internal layers, which reduces the operating life of the device. Networks built into many integrated circuits provide some protection, but in many cases, the discharge contains enough power to alter device parameters or melt silicon junctions.

The table below shows the amount of static electricity generated by common activities associated with servicing computers.

Activity	Generated Electrostatic Voltage		
	Relative Humidity		
	10%	40%	50%
Walking across carpet	35,000 V	15,000 V	7,500 V
Walking across vinyl floor	12,000 V	5,000 V	3,000 V
Motions of bench worker	6,000 V	800 V	400 V
Removing DIPS from plastic tubes	2,000 V	700 V	400 V
Removing DIPS from vinyl trays	11,500 V	4,000 V	2,000 V
Removing DIPS from styrofoam	14,500 V	5,000 V	3,500 V
Removing bubble pack from PCBs	26,000 V	20,000 V	7,000 V
Packing PCBs in foam-lined box	21,000 V	11,000 V	5,000 V

CAUTION: As little as 700 Volts can degrade Notebook components. Be sure to ground yourself before touching the Notebook or its subassemblies.

1.800.AT.COMPAQ

maintenance & service guide

Presario 1800 Series

Models: XL180, XL181, XL182, XL183, XL185,
and XL190, XL191, XL192

Tool and Software Requirements

The following items are required to service the Notebook:

- Torx T-8 screwdriver
- 5mm nut drivers (for screwlocks and standoffs)
- Small standard screwdriver
- Small Phillips screwdriver
- Diagnostics software

Screws

The screws used in the Notebook are **not** interchangeable. If an incorrect screw is used during the reassembly process, it can damage the unit. Compaq strongly recommends that all screws removed during disassembly be kept with the part that was removed, then returned to their proper locations.

Connectors and Plastic Parts

Plastic parts can be damaged by the use of excessive force during disassembly and reassembly. When handling plastic parts, use care. Apply pressure only at the points designated in the instructions.

maintenance & service guide

Presario 1800 Series

Models: **XL180, XL181, XL182, XL183, XL185,**
and **XL190, XL191, XL192**

ZIF Connector

The 1800XL Series Notebooks use zero insertion force (ZIF) connectors on the system board.

 **CAUTION:** A ZIF connector and its attached cable can be easily damaged. Handle only the connector slide when removing or replacing a cable. Never pull or twist on the cable while it is connected.

To remove a cable from a ZIF connector, lift both corners of the ZIF connector and slide the cable out simultaneously with constant light force.

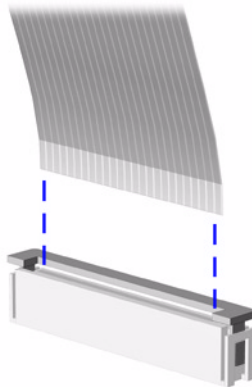

 **CAUTION:** When servicing this Notebook, ensure that cables are placed in their proper location during the reassembly process. Improper cable placement can damage the Notebook.

maintenance & service guide

Presario 1800 Series

Models: **XL180, XL181, XL182, XL183, XL185,**
and **XL190, XL191, XL192**

Cables

Most cables used throughout the unit are ribbon cables.

Cables must be handled with extreme care to avoid damage. Use the following precautions when handling cables to avoid damage to the cable and Notebook:

- Always handle cables by their connectors.
- In all cases, avoid bending, twisting, pulling, or tearing cables.
- Apply only the minimum force required to seat or unseat cables from their connectors.
- Ensure that cables are routed in such a manner that they cannot be caught or snagged by parts being removed or replaced.
- Handle flex cables with extreme care; they can tear easily.

 **CAUTION:** When servicing these Notebooks, ensure that cables are placed in their proper location during the reassembly process. Improper cable placement can cause severe damage to the unit.

The following illustrations show the proper placement for each cable:

- [Hard Drive Ribbon Cable](#)
- [CD/DVD Ribbon Cable](#)
- [Diskette Drive Ribbon Cable](#)
- [Speaker Assembly Cable](#)
- [Keyboard Ribbon Cable](#)

maintenance & service guide

Presario 1800 Series

Models: XL180, XL181, XL182, XL183, XL185,
and XL190, XL191, XL192

Hard Drive Ribbon Cable

The position for the hard drive ribbon cable is shown below.



CAUTION: When servicing the Notebook, ensure that cables are placed in their proper location during the reassembly process. Improper cable placement can damage the Notebook.

[Removing the Hard Drive](#)

maintenance & service guide

Presario 1800 Series

Models: XL180, XL181, XL182, XL183, XL185,
and XL190, XL191, XL192

CD/DVD Ribbon Cable

The ribbon cable position for the CD or DVD drive is shown below.



CAUTION: When servicing the Notebook, ensure that cables are placed in their proper location during the reassembly process. Improper cable placement can damage the Notebook.

[Removing the CD/DVD Drive](#)

maintenance & service guide

Presario 1800 Series

Models: XL180, XL181, XL182, XL183, XL185,
and XL190, XL191, XL192

Diskette Drive Ribbon Cable

The ribbon cable position for the diskette drive is shown below.



CAUTION: When servicing the Notebook, ensure that cables are placed in their proper location during the reassembly process. Improper cable placement can damage the Notebook.

[Removing the Diskette Drive](#)

maintenance & service guide

Presario 1800 Series

Models: XL180, XL181, XL182, XL183, XL185,
and XL190, XL191, XL192

Speaker Assembly Cable

The cable position for the speaker assembly is shown below. The cable is routed under the battery charger (voltage converter) board and under the edge of the system board.



CAUTION: When servicing the Notebook, ensure that cables are placed in their proper location during the reassembly process. Improper cable placement can damage the Notebook.

[Removing the Speaker Assembly](#)

maintenance & service guide

Presario 1800 Series

Models: XL180, XL181, XL182, XL183, XL185,
and XL190, XL191, XL192

Modem Cable

The cable position for the modem is shown below.

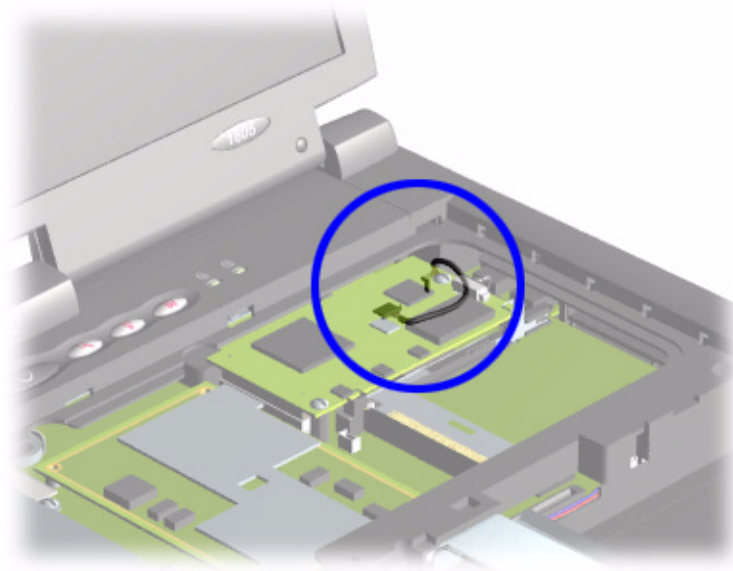

CAUTION: When servicing the Notebook, ensure that cables are placed in their proper location during the reassembly process. Improper cable placement can damage the Notebook.

[Removing the Modem](#)

maintenance & service guide

Presario 1800 Series

Models: XL180, XL181, XL182, XL183, XL185,
and XL190, XL191, XL192

Keyboard Ribbon Cable

The ribbon cable position for the keyboard is shown below.



CAUTION: When servicing this Notebook, ensure that cables are placed in their proper location during the reassembly process. Improper cable placement can damage the Notebook.

[Removing the Keyboard](#)

maintenance & service guide

Presario 1800 Series

Models: **XL180, XL181, XL182, XL183, XL185,**
and **XL190, XL191, XL192**

Preparing the Notebook for Disassembly

Before beginning the removal or replacement of any Notebook components, complete the following steps:

1. Disconnect the AC power source and any external devices.
2. Remove the QuikDock ([pg 12](#)).
3. Remove any PC Cards.
4. Remove the battery pack ([pg 13](#)).

Important: The battery pack should be removed before performing any internal maintenance on the Notebook.



WARNING: Metal objects can damage the battery pack as well as the battery contacts in the battery compartment. To prevent damage, do not allow metal objects to touch the battery contacts. Place only the battery pack for the Compaq Presario 1800XL Series Portable Notebooks into the battery compartment. Do not force the battery pack into the bay if insertion is difficult.



CAUTION: Do not crush, puncture, or incinerate the battery pack. Do not open a battery pack; this action damages the pack, makes it unusable, and exposes potentially harmful battery components. No field-serviceable parts are located inside the battery pack.

Note: Compaq Presario 1800XL Series Portable Notebooks have several screws of various sizes that are **not** interchangeable. Care must be taken during reassembly to ensure that the correct screws are used in their correct location. During removal keep screws with their respective subassembly.

Important: As each component is removed from the Notebook, place the components and its associated screws away from the work area to prevent damage.

maintenance & service guide

Presario 1800 Series

Models: XL180, XL181, XL182, XL183, XL185,
and XL190, XL191, XL192

Disconnecting the QuikDock

To disconnect the Notebook from the QuikDock, complete the following steps:

1. Lift up the handle ❶ on top of the QuikDock.
2. Lift the Notebook ❷ straight up.

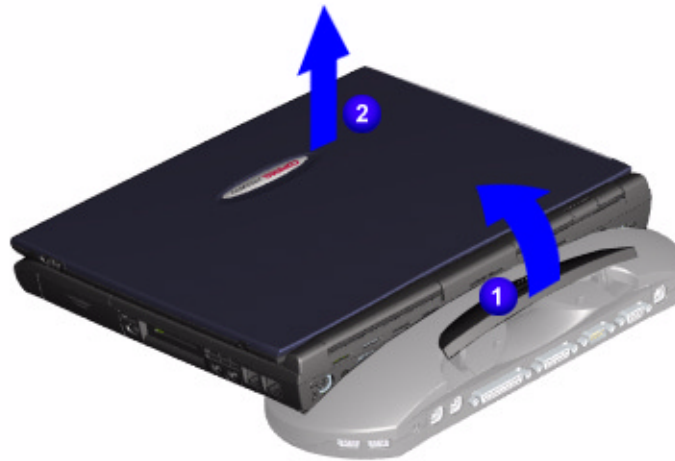

maintenance & service guide

Presario 1800 Series
Models: XL180, XL181, XL182, XL183, XL185,
and XL190, XL191, XL192

Removing the Battery

To remove the battery pack, complete the following steps:

1. Slide the battery compartment door down ❶ and remove it from the chassis.
2. Pull the battery ❷ from the chassis by the tab located on the end of the battery pack.

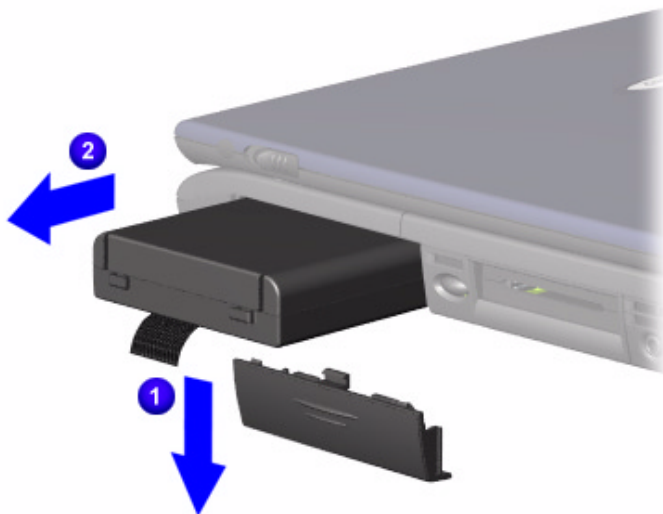

To replace the battery, reverse these procedures.

Important: The battery pack should be removed before performing any internal maintenance on the Notebook.

WARNING: Metal objects can damage the battery pack as well as the battery contacts in the battery compartment. To prevent damage, do not allow metal objects to touch the battery contacts. Place only the battery pack for Compaq Presario 1800XL Series Portable Notebooks in the battery compartment. Do not force the battery pack into the bay if insertion does not occur easily.

CAUTION: Do not crush, puncture, or incinerate the battery pack. Do not open a battery pack; this action damages the pack, makes it unusable, and exposes potentially harmful battery components. No field-serviceable parts are located inside the battery pack.

maintenance & service guide

Presario 1800 Series

Models: XL180, XL181, XL182, XL183, XL185,
and XL190, XL191, XL192

Removing the Palmrest Cover with TouchPad

Note: It is not necessary to remove the display panel assembly to access the interior components of the Notebook.

To remove the Palmrest cover with TouchPad, complete the following steps:

1. Prepare the Notebook for disassembly ([pg 11](#)).
2. Close the display and turn the Notebook upside down.
3. Remove five screws from the underside of the Notebook.

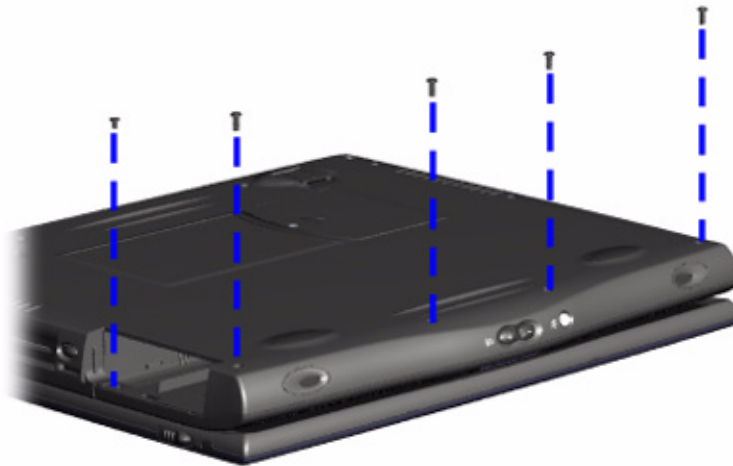

Continued on the next page.

maintenance & service guide

Presario 1800 Series

Models: **XL180, XL181, XL182, XL183, XL185,**
and **XL190, XL191, XL192**

4. Turn the Notebook over (right side up).
5. Pull the display release latches and open the display.
6. Lift up the front end of the Palmrest cover and remove it from the groove in the chassis.

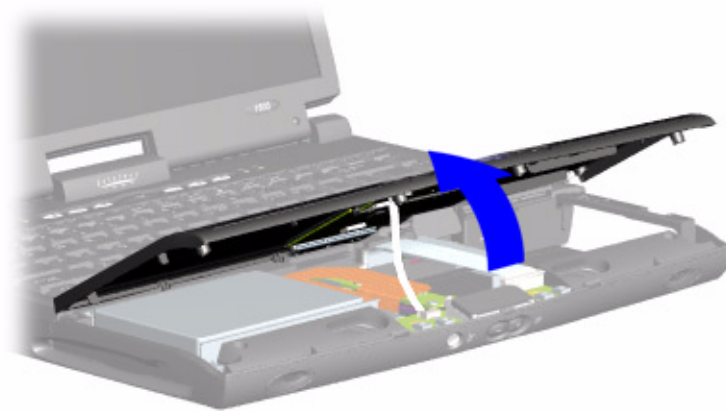

Continued on the next page.

maintenance & service guide

Presario 1800 Series

Models: XL180, XL181, XL182, XL183, XL185,
and XL190, XL191, XL192

7. Disconnect the flex cable from the [ZIF Connector](#) on the DisqPlay module.

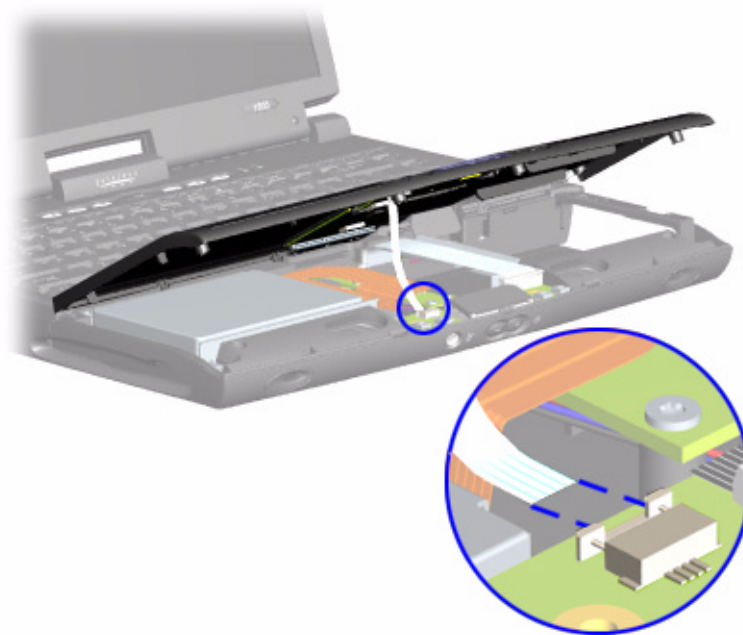

To replace the Palmrest cover, reverse these procedures.

maintenance & service guide

Presario 1800 Series
Models: XL180, XL181, XL182, XL183, XL185,
and XL190, XL191, XL192

Removing the Keyboard

To remove the keyboard, complete the following steps:

1. Prepare the Notebook for disassembly ([pg 11](#)).
2. Remove the Palmrest cover with TouchPad ([pg 14](#)).
3. Gently lift ❶ up the front of the keyboard and disconnect ❷ the flex cable from the [ZIF Connector](#) on the system board and remove the keyboard.

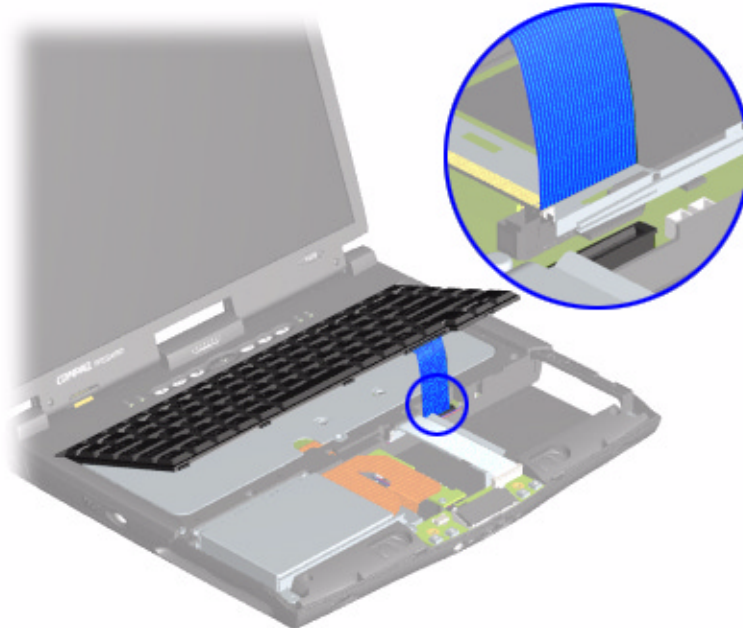

To replace the keyboard, reverse these procedures.

Note: When replacing the keyboard, the [Keyboard Ribbon Cable](#) should fold behind the [ZIF Connector](#) rather than underneath the keyboard.

maintenance & service guide

Presario 1800 Series

Models: XL180, XL181, XL182, XL183, XL185,
and XL190, XL191, XL192

Removing the Internet Zone Cover

(Status Panel Assembly)

Note: Illustrations may show parts removed that are not part of this procedure. It is necessary to remove only the parts listed in the written procedure.

To remove the Internet Zone cover, complete the following steps:

1. Prepare the Notebook for disassembly ([pg 11](#)).
2. Open the display and squeeze the sides of the display hinge covers while sliding them off the hinges.

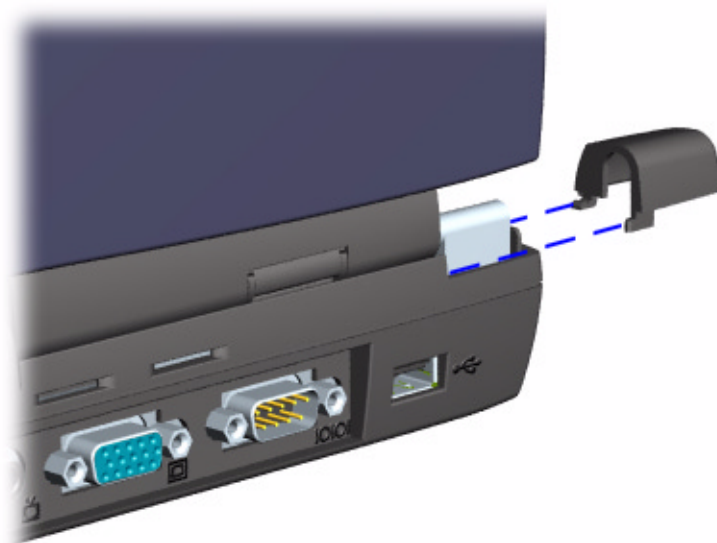

Continued on the next page.

maintenance & service guide

Presario 1800 Series

Models: XL180, XL181, XL182, XL183, XL185,
and XL190, XL191, XL192

3. Remove two innermost screws from the display hinges that secure the Internet Zone cover to the chassis.

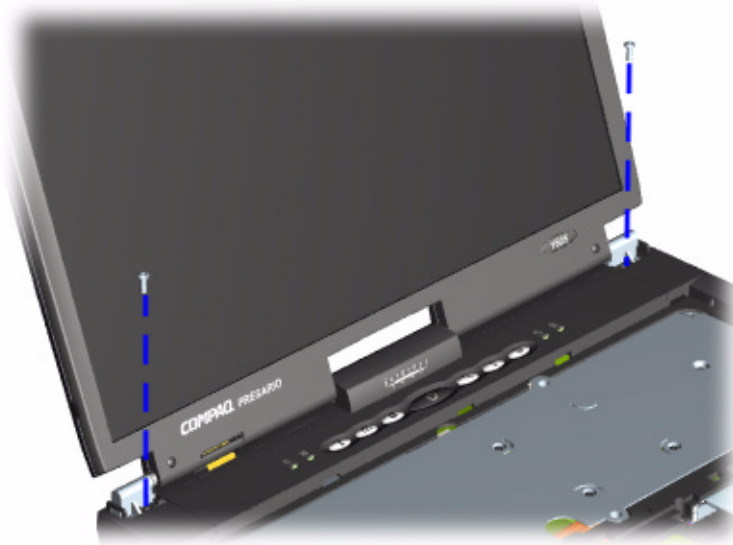

4. Turn the unit upside down and remove the two screws located near the back of the Notebook that secure the Internet Zone cover to the chassis.

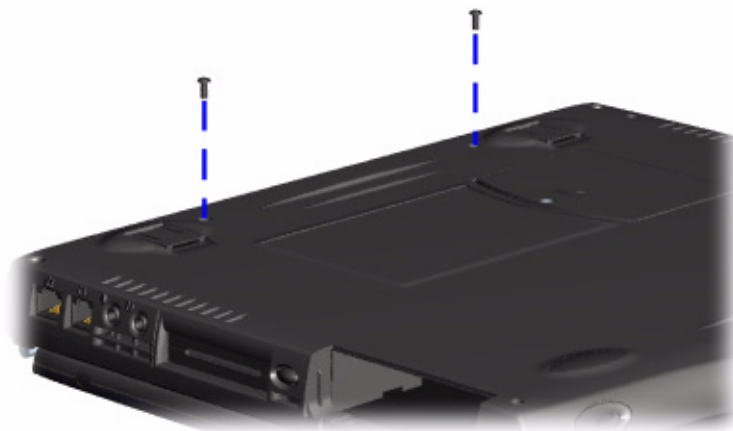

Continued on the next page.

maintenance & service guide

Presario 1800 Series

Models: XL180, XL181, XL182, XL183, XL185,
and XL190, XL191, XL192

5. Turn the unit over (right side up) and open the display.
6. Lift up one corner of the Internet Zone cover, ❶ push forward from the back (center piece) to release the snaps on the Internet Zone cover, and ❷ remove from the chassis.

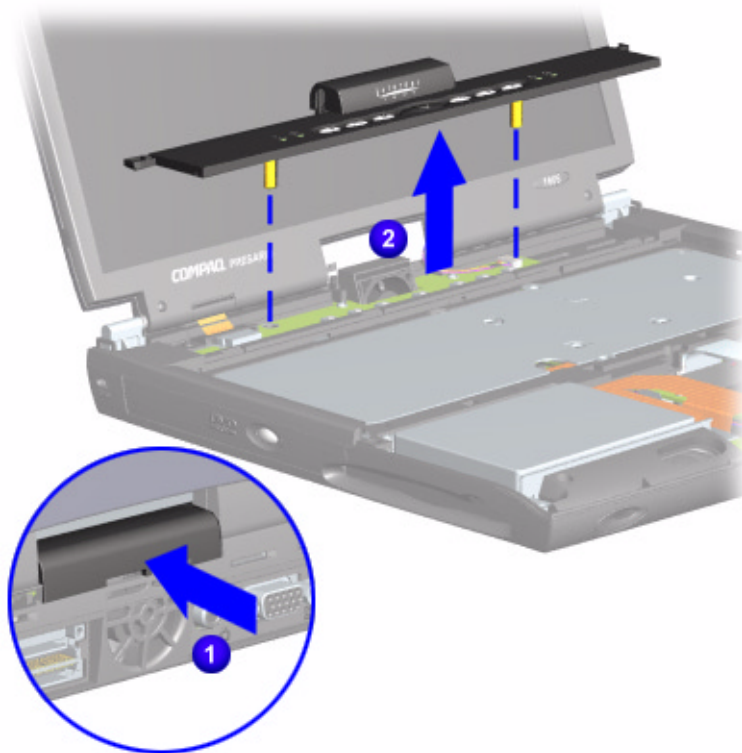

To replace the Internet Zone cover, reverse these procedures.

maintenance & service guide

Presario 1800 Series
Models: XL180, XL181, XL182, XL183, XL185,
and XL190, XL191, XL192

Removing the Internet Button Board

Note: Illustrations may show parts removed that are not part of this procedure. It is necessary to remove only the parts listed in the written procedure.

To remove the Internet button board, complete the following steps:

1. Prepare the Notebook for disassembly ([pg 11](#)).
2. Remove the Internet Zone Cover ([pg 18](#)).
3. Remove the screw securing the display flex cable bracket and disconnect both the display flex cable and backlight cable from the system board.

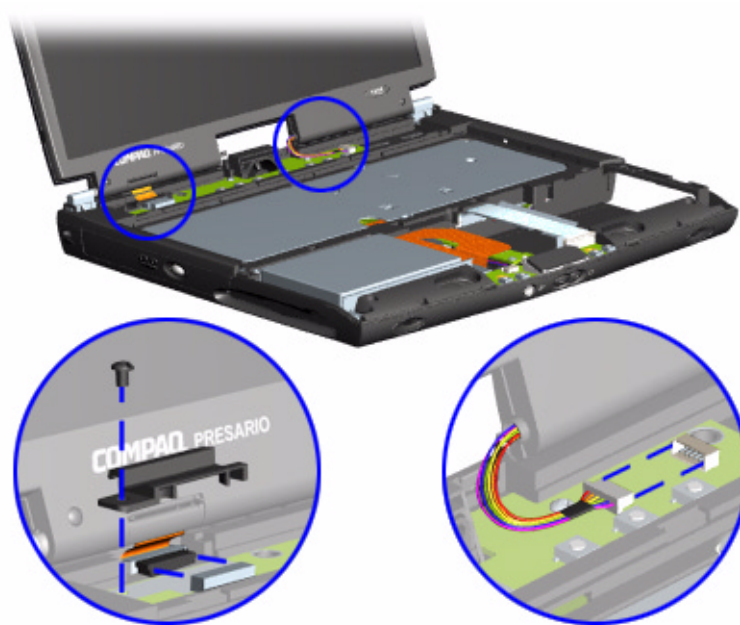

Continued on the next page.

maintenance & service guide

Presario 1800 Series

Models: XL180, XL181, XL182, XL183, XL185,
and XL190, XL191, XL192

4. Remove two screws securing the Internet button board and remove from the chassis.

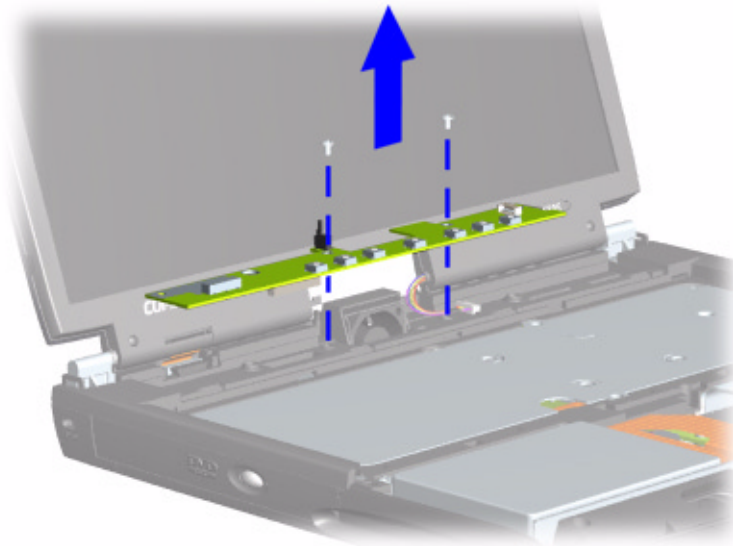

To replace the Internet button board, reverse these procedures.

Presario 1800 Series
Models: XL180, XL181, XL182, XL183, XL185,
and XL190, XL191, XL192

Removing the Heatspreader

To remove the Heatspreader, complete the following steps:

1. Prepare the Notebook for disassembly ([pg 11](#)).
2. Remove the Palmrest cover with TouchPad ([pg 14](#)).
3. Remove the keyboard ([pg 17](#)).
4. Remove six screws from the Heatspreader and lift out of the chassis.

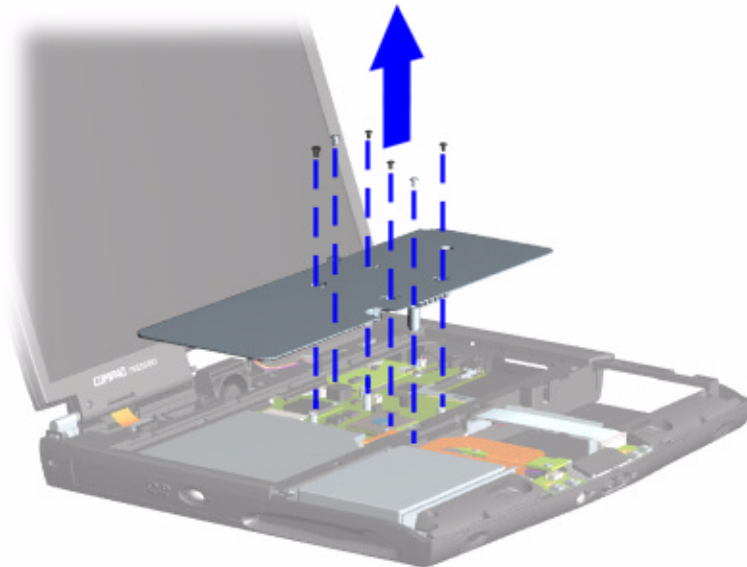

To replace the Heatspreader, reverse these procedures.

Note: If the thermal pads on the Heatspreader are missing or damaged, a new Heatspreader should be installed.

Important: Before installing a new Heatspreader, remove the plastic covering from the thermal pads.



WARNING: To prevent damage, do not use excessive force when replacing the screws.

maintenance & service guide

Presario 1800 Series
Models: XL180, XL181, XL182, XL183, XL185,
and XL190, XL191, XL192

Removing the Modem

To remove the modem, complete the following steps:

1. Prepare the Notebook for disassembly ([pg 11](#)).
2. Remove the Palmrest cover with TouchPad ([pg 14](#)).
3. Remove the keyboard ([pg 17](#)).
4. Remove the Internet Zone cover ([pg 18](#)).
5. Remove the Heatspreader ([pg 23](#)).
6. Remove three screws from the modem board and lift the modem off the connector on the system board.
7. Disconnect the cable from the modem board.

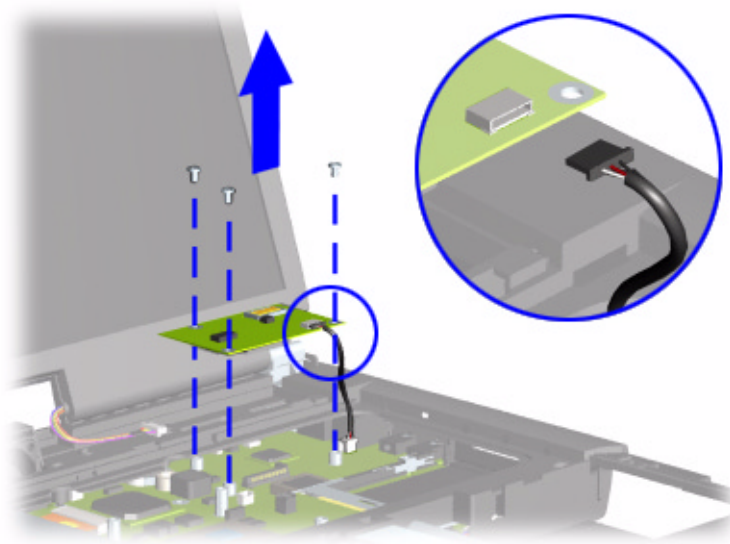

To replace the modem board, reverse these procedures.

CAUTION: When replacing the modem, ensure that the [Modem Cable](#) is placed in its proper location during the reassembly process. Improper cable placement can damage the Notebook.

maintenance & service guide

Presario 1800 Series

Models: XL180, XL181, XL182, XL183, XL185,
and XL190, XL191, XL192

Removing the Hard Drive

Note: Illustrations may show parts removed that are not part of this procedure. It is necessary to remove only the parts listed in the written procedure.

To remove the hard drive, complete the following steps:

1. Prepare the Notebook for disassembly ([pg 11](#)).
2. Remove the Palmrest cover with TouchPad ([pg 14](#)).
3. Remove three screws from the hard drive mounting bracket.
4. Disconnect the hard drive data cable and lift out the hard drive.

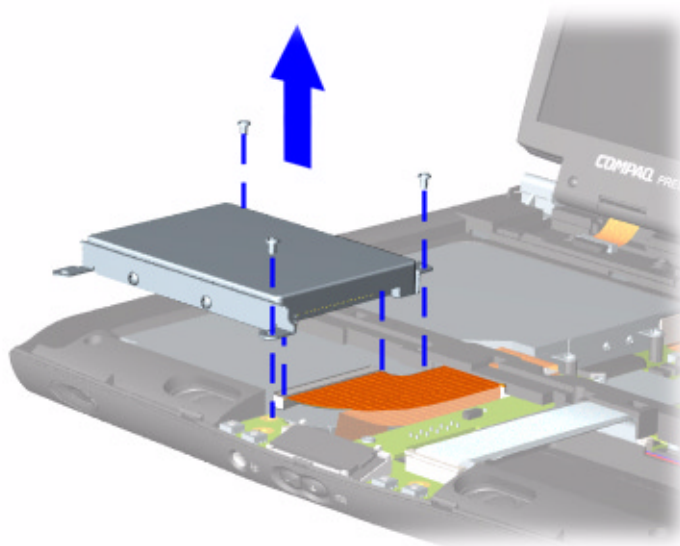

Continued on the next page.

maintenance & service guide

Presario 1800 Series

Models: XL180, XL181, XL182, XL183, XL185,
and XL190, XL191, XL192

Removing the Hard Drive Mounting Brackets

To remove the hard drive mounting brackets, remove two screws from each of side of the hard drive.

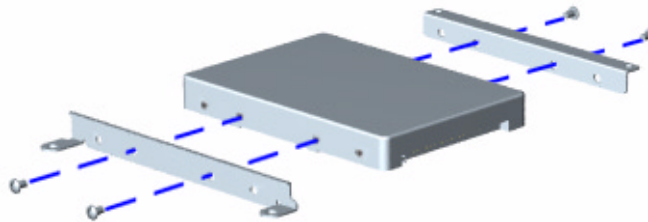

To replace the hard drive and mounting brackets, reverse these procedures.

maintenance & service guide

Presario 1800 Series
Models: XL180, XL181, XL182, XL183, XL185,
and XL190, XL191, XL192

Removing the DisqPlay Module

Note: Illustrations may show parts removed that are not part of this procedure. It is necessary to remove only the parts listed in the written procedure.

To remove the DisqPlay module, complete the following steps:

1. Prepare the Notebook for disassembly ([pg 11](#)).
2. Remove the Palmrest cover with TouchPad ([pg 14](#)).
3. Remove the hard drive ([pg 25](#)).
4. Lift up the DisqPlay module and disconnect the flex cable from [ZIF Connector](#) on the module.
5. Remove the DisqPlay module from the chassis.

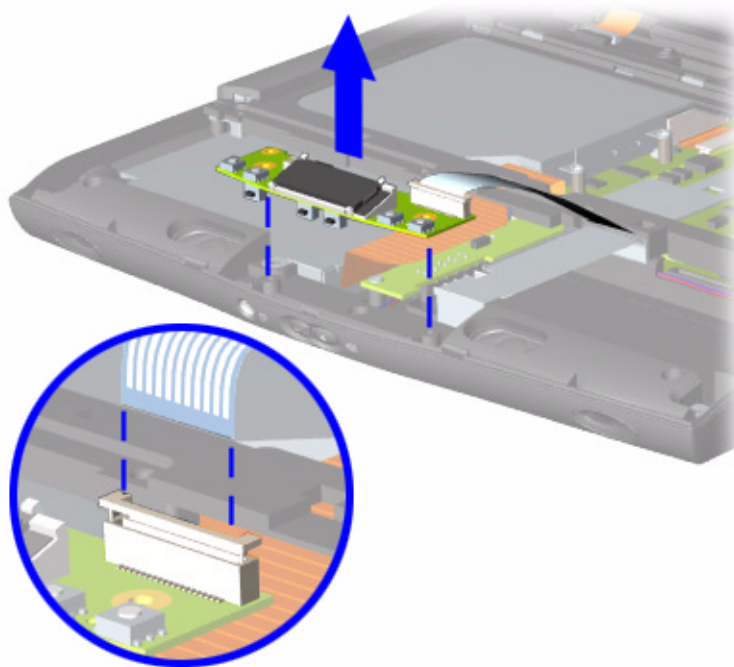

To replace the DisqPlay module, reverse these procedures.

maintenance & service guide

Presario 1800 Series

Models: **XL180, XL181, XL182, XL183, XL185,**
and **XL190, XL191, XL192**

Removing the Processor

To remove the processor, complete the following steps:

1. Prepare the Notebook for disassembly ([pg 11](#)).
2. Remove the Palmrest cover with TouchPad ([pg 14](#)).
3. Remove the keyboard ([pg 17](#)).
4. Remove the Heatspreader ([pg 23](#)).
5. If the processor matches the one shown below, proceed with step **a** below. If the processor does not match the one shown, skip step **a** and proceed with step **b** on the next page.
 - a. Place tip of standard screwdriver in center slot, twist screwdriver toward "Free" until it snaps, and lift processor from the chassis.

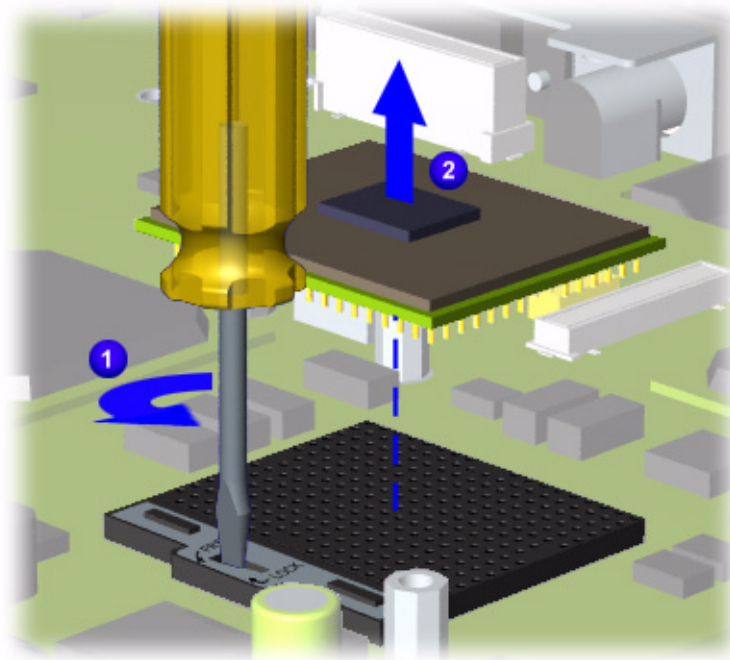

Continued on the next page.

maintenance & service guide

Presario 1800 Series

Models: XL180, XL181, XL182, XL183, XL185,
and XL190, XL191, XL192

- b. With standard screwdriver, turn screw counter-clockwise toward "0" and lift processor from the chassis.

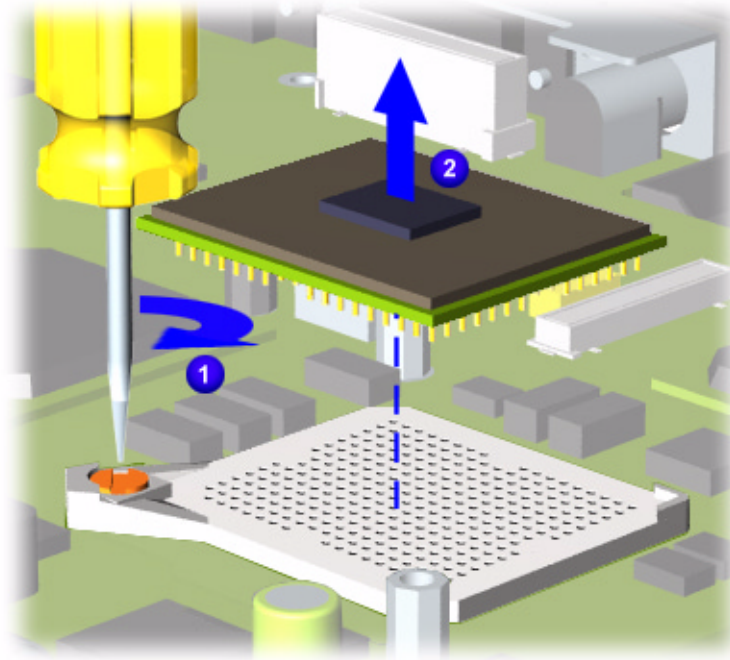

To replace the processor, complete the following:

1. Fully align the processor connector with the system board connector.
2. Press down carefully on the processor directly over the connectors to seat the processor.
3. Reassemble the remaining subassemblies by reversing their removal procedures.

maintenance & service guide

Presario 1800 Series

Models: **XL180, XL181, XL182, XL183, XL185,**
and **XL190, XL191, XL192**

Removing the CD/DVD Drive

To remove the CD/DVD Drive, complete the following steps:

1. Prepare the Notebook for disassembly ([pg 11](#)).
2. Remove the Palmrest cover with TouchPad ([pg 14](#)).
3. Remove the keyboard ([pg 17](#)).
4. Remove the Heatspreader ([pg 23](#)).
5. Turn the Notebook over (upside down) and remove the two screws that secure the CD/DVD drive to the chassis.

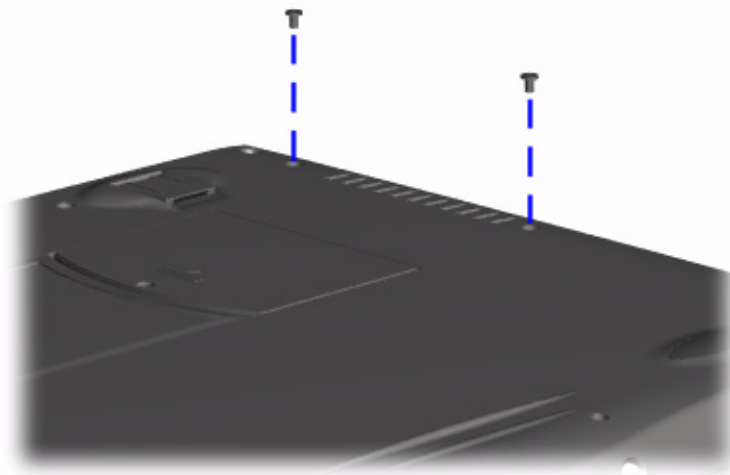

Continued on the next page.

maintenance & service guide

Presario 1800 Series

Models: XL180, XL181, XL182, XL183, XL185,
and XL190, XL191, XL192

6. Turn the unit over (right side up) and remove the two screws located at the back of the CD/DVD drive.

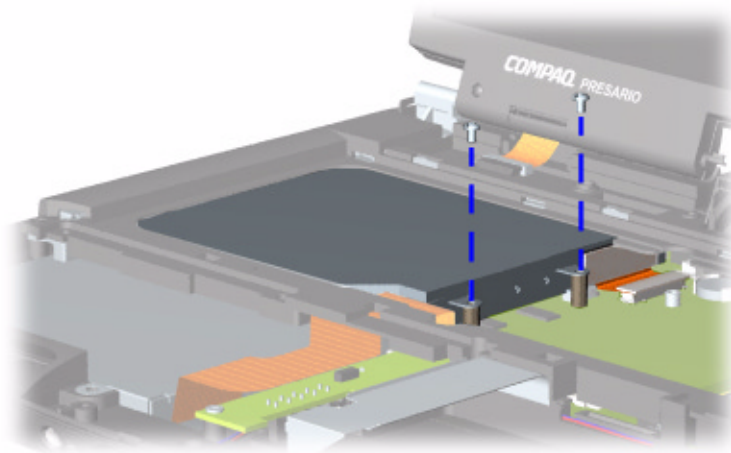

7. Disconnect the CD/DVD drive cable and push forward from the back of the drive to slide the drive out of the chassis.

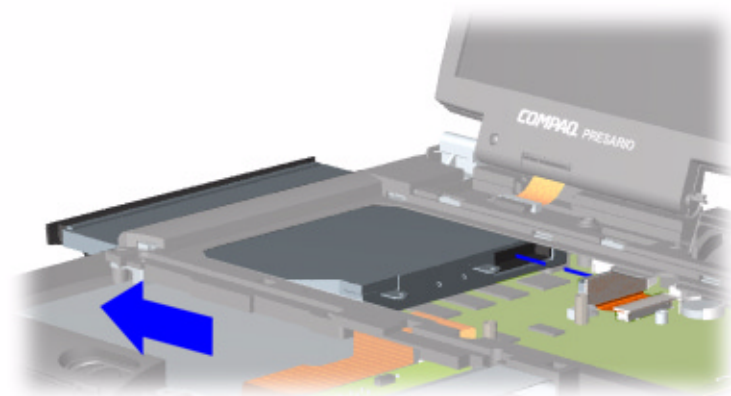

To replace the CD/DVD drive, reverse these procedures.

CAUTION: When replacing the CD/DVD drive, ensure that the [CD/DVD Ribbon Cable](#) is placed in its proper location during the reassembly process. Improper cable placement can damage the Notebook.

maintenance & service guide

Presario 1800 Series
Models: XL180, XL181, XL182, XL183, XL185,
and XL190, XL191, XL192

Removing the Display Panel Assembly

Note: Illustrations may show parts removed that are not part of this procedure. It is necessary to remove only the parts listed in the written procedure.

To remove the display panel assembly, complete the following steps:

1. Prepare the Notebook for disassembly ([pg 11](#)).
2. Remove the Internet Zone cover ([pg 18](#)).
3. Remove the screw securing the display flex cable bracket and disconnect the display flex cable and backlight cable from the Internet button board.

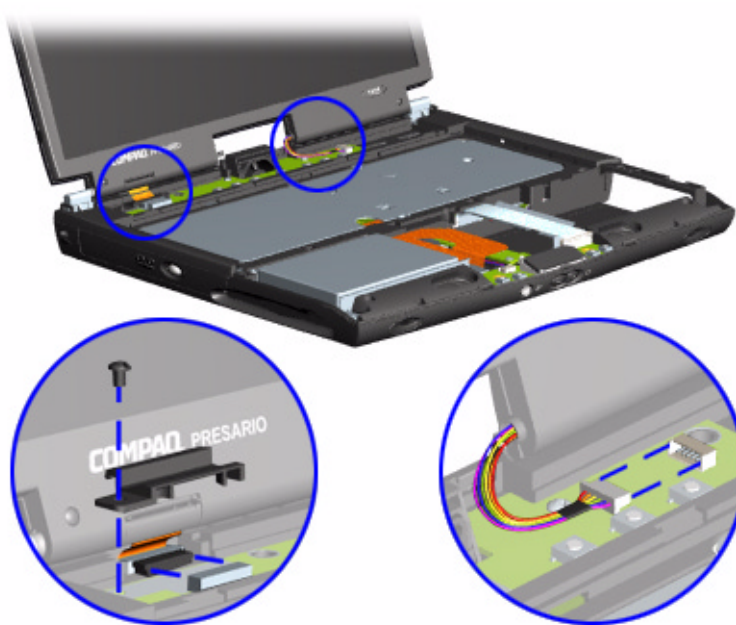

Continued on the next page.

maintenance & service guide

Presario 1800 Series

Models: XL180, XL181, XL182, XL183, XL185,
and XL190, XL191, XL192

4. Remove the two outermost screws securing the display panel to the chassis.

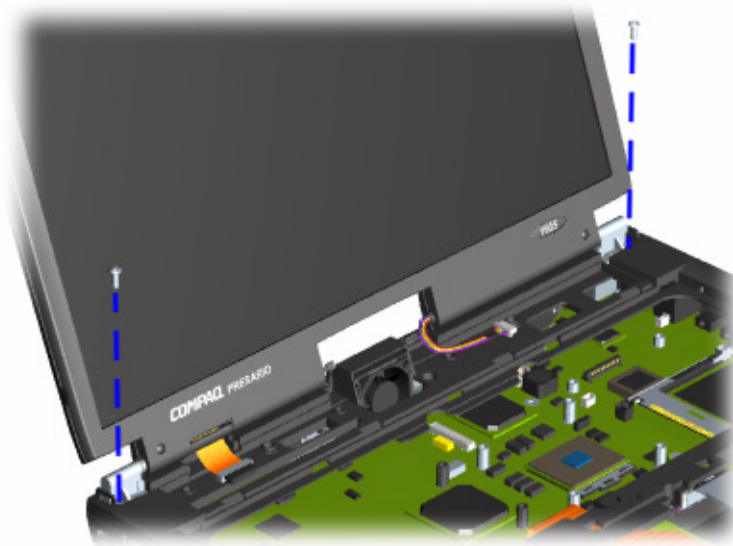

5. Remove the display assembly from the chassis.



To replace the display panel, reverse these procedures.

maintenance & service guide

Presario 1800 Series

Models: **XL180, XL181, XL182, XL183, XL185,**
and **XL190, XL191, XL192**

Removing the Upper CPU Cover

To remove the upper CPU cover, complete the following:

1. Prepare the Notebook for disassembly ([pg 11](#)).
2. Remove the Palmrest cover with TouchPad ([pg 14](#)).
3. Remove the keyboard ([pg 17](#)).
4. Remove the Heatspreader ([pg 23](#)).
5. Remove the Internet Zone cover ([pg 18](#)).
6. Remove the Internet button board ([pg 21](#)).
7. Remove the hard drive ([pg 25](#)).
8. Remove the display panel assembly ([pg 32](#)).
9. Remove four screws located on the top of the upper CPU cover and lift the cover off the chassis.

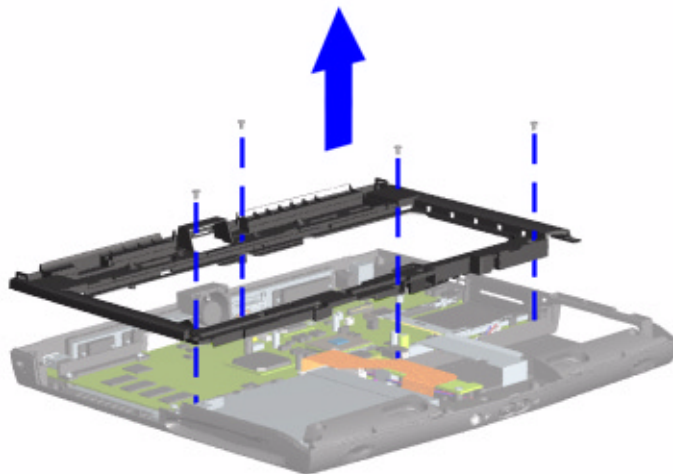

To replace the upper CPU cover, reverse these procedures.

maintenance & service guide

Presario 1800 Series

Models: **XL180, XL181, XL182, XL183, XL185,**
and **XL190, XL191, XL192**

Removing the Fan Assembly

To remove the fan assembly, complete the following:

1. Prepare the Notebook for disassembly ([pg 11](#)).
2. Remove the Palmrest cover with TouchPad ([pg 14](#)).
3. Remove the keyboard ([pg 17](#)).
4. Remove the Heatspreader ([pg 23](#)).
5. Remove the Internet Zone cover ([pg 18](#)).
6. Remove the Internet button board ([pg 21](#)).
7. Remove the display panel assembly ([pg 32](#)).
8. Remove the hard drive ([pg 25](#)).
9. Remove the upper CPU cover ([pg 34](#)).
10. Disconnect the fan cable from the connector on the system board and lift the fan assembly from the chassis slot.

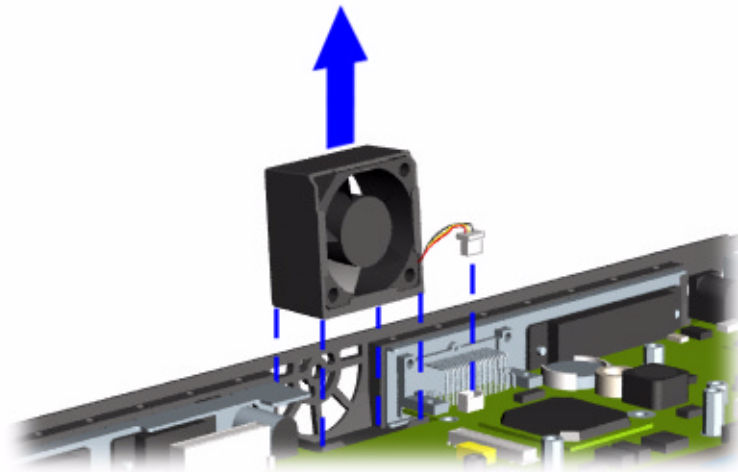

Continued on the next page.

maintenance & service guide

Presario 1800 Series

Models: XL180, XL181, XL182, XL183, XL185,
and XL190, XL191, XL192

To remove the fan gasket, pull the gasket from the fan.

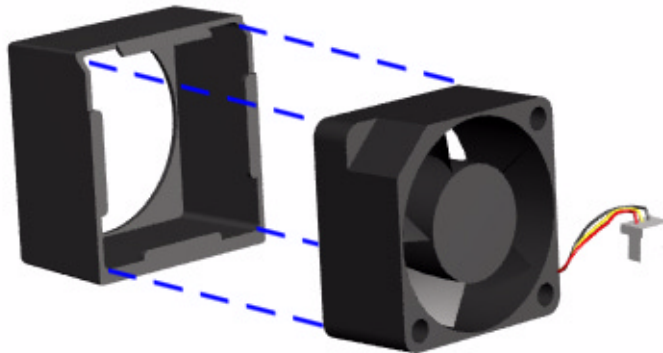

To replace the fan assembly and gasket, reverse these procedures.

Important: When replacing the fan assembly ensure that the arrow (located on the side of the fan near the connector) is pointing inward.

maintenance & service guide

Presario 1800 Series

Models: **XL180, XL181, XL182, XL183, XL185,**
and **XL190, XL191, XL192**

Removing the Real Time Clock Battery

 **CAUTION:** Removing the RTC battery [clears the power-on password](#) and removes all setup attributes that are programmed in the CMOS.

To remove the RTC battery, complete the following steps:

1. Prepare the Notebook for disassembly ([pg 11](#)).
2. Remove the Palmrest cover with TouchPad ([pg 14](#)).
3. Remove the keyboard ([pg 17](#)).
4. Remove the Heatspreader ([pg 23](#)).
5. Remove the Internet Zone cover ([pg 18](#)).
6. Remove the Internet button board ([pg 21](#)).
7. Remove the hard drive ([pg 25](#)).
8. Remove the upper CPU cover ([pg 34](#)).

Continued on the next page.

maintenance & service guide

Presario 1800 Series

Models: **XL180, XL181, XL182, XL183, XL185,**
and **XL190, XL191, XL192**

9. Locate the RTC battery on the system board behind the CD/DVD drive near the back of the unit.
10. Using your fingers or a small, non-metallic object, gently pry the RTC battery upward and remove it from the battery socket.

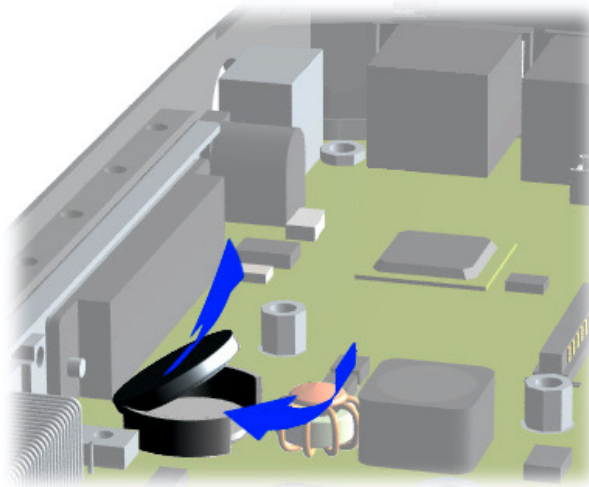

To replace the RTC battery, press the battery firmly into the socket and reassemble the remaining components by reversing their removal procedures.

maintenance & service guide

Presario 1800 Series
Models: XL180, XL181, XL182, XL183, XL185,
and XL190, XL191, XL192

Removing the Diskette Drive

To remove the diskette drive, complete the following steps:

1. Prepare the Notebook for disassembly ([pg 11](#)).
2. Remove the Palmrest cover with TouchPad ([pg 14](#)).
3. Remove the keyboard ([pg 17](#)).
4. Remove the Heatspreader ([pg 23](#)).
5. Remove the CD/DVD drive ([pg 30](#)).
6. Remove the Internet Zone cover ([pg 18](#)).
7. Remove the Internet button board ([pg 21](#)).
8. Remove the display panel assembly ([pg 32](#)).
9. Remove the hard drive ([pg 25](#)).
10. Remove the upper CPU cover ([pg 34](#)).
11. Remove the screw from the diskette drive retaining bracket.

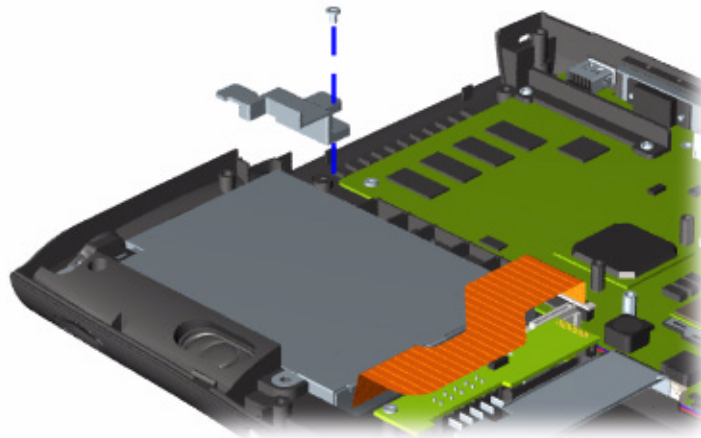

Continued on the next page.

maintenance & service guide

Presario 1800 Series

Models: **XL180, XL181, XL182, XL183, XL185,**
and **XL190, XL191, XL192**

12. Remove the screw that connects the diskette drive bracket to the chassis.
13. Disconnect the diskette drive data cable from the [ZIF Connector](#) on the system board and lift the diskette drive from the chassis.

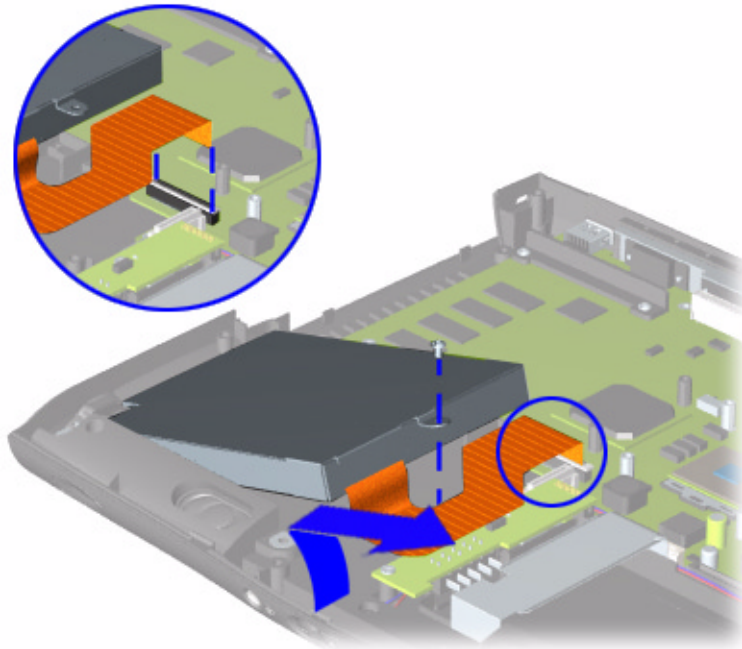

To replace the diskette drive, reverse these procedures.

CAUTION: When replacing the diskette drive, ensure that the [Diskette Drive Ribbon Cable](#) is placed in its proper location during the reassembly process. Improper cable placement can damage the Notebook.

Presario 1800 Series

Models: **XL180, XL181, XL182, XL183, XL185,**
and **XL190, XL191, XL192**

Removing the Battery Charger Board

(Voltage Converter Board)

To remove the battery charger board, complete the following:

1. Prepare the Notebook for disassembly ([pg 11](#)).
2. Remove the Palmrest cover with TouchPad ([pg 14](#)).
3. Remove the keyboard ([pg 17](#)).
4. Remove the Heatspreader ([pg 23](#)).
5. Remove the Internet Zone cover ([pg 18](#)).
6. Remove the Internet button board ([pg 21](#)).
7. Remove the display panel assembly ([pg 32](#)).
8. Remove the hard drive ([pg 25](#)).
9. Remove the upper CPU cover ([pg 34](#)).
10. Remove two screws from the battery charger board and unplug the board from the connector on the system board.
11. Lift the battery charger board out of the chassis.

Note: Retain plastic insulator for reassembly with replacement battery charger board.

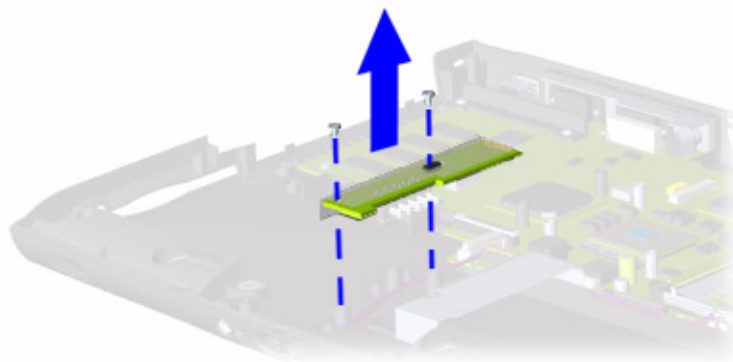

To replace the battery charger board, reverse these procedures.

Important: When replacing the battery charger board, ensure that the pins are aligned with the connector on the system board.

maintenance & service guide

Presario 1800 Series

Models: **XL180, XL181, XL182, XL183, XL185,**
and **XL190, XL191, XL192**

Removing the Speaker Assembly

To remove the speaker assembly, complete the following:

1. Prepare the Notebook for disassembly ([pg 11](#)).
2. Remove the Palmrest cover with TouchPad ([pg 14](#)).
3. Remove the keyboard ([pg 17](#)).
4. Remove the Heatspreader ([pg 23](#)).
5. Remove the Internet Zone cover ([pg 18](#)).
6. Remove the Internet button board ([pg 21](#)).
7. Remove the display panel assembly ([pg 32](#)).
8. Remove the hard drive ([pg 25](#)).
9. Remove the upper CPU cover ([pg 34](#)).
10. Remove the battery charger board ([pg 41](#)).

Continued on the next page.

maintenance & service guide

Presario 1800 Series

Models: XL180, XL181, XL182, XL183, XL185,
and XL190, XL191, XL192

11. Disconnect the speaker cables from the system board and lift the speaker assembly from the chassis.

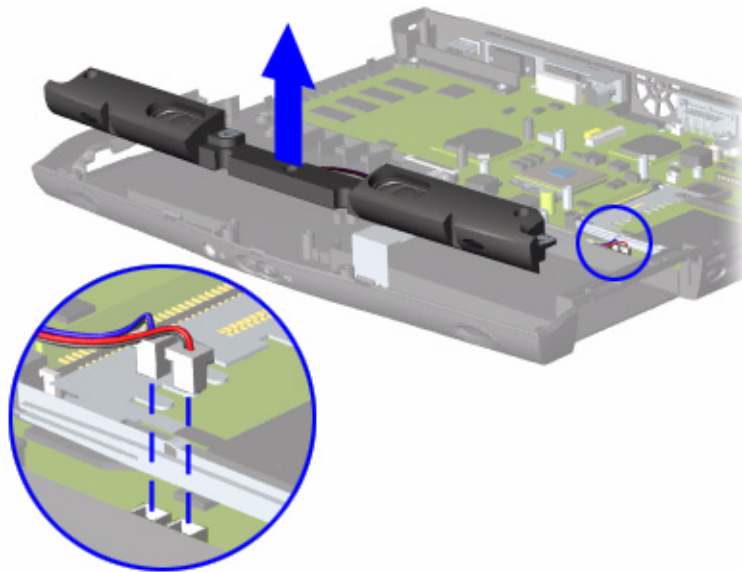

To replace the speaker assembly, reverse these procedures.

CAUTION: When replacing the speaker assembly, ensure that the [Speaker Assembly Cable](#) is placed in its proper location. Improper cable placement can damage the Notebook.

maintenance & service guide

Presario 1800 Series

Models: **XL180, XL181, XL182, XL183, XL185,**
and **XL190, XL191, XL192**

Removing the System Board

To remove the system board, complete the following steps:

1. Prepare the Notebook for disassembly ([pg 11](#)).
2. Remove the Palmrest cover with TouchPad ([pg 14](#)).
3. Remove the keyboard ([pg 17](#)).
4. Remove the Heatspreader ([pg 23](#)).
5. Remove the Internet Zone cover ([pg 18](#)).
6. Remove the Internet button board ([pg 21](#)).
7. Remove the display panel assembly ([pg 32](#)).
8. Remove the hard drive ([pg 25](#)).
9. Remove the upper CPU cover ([pg 34](#)).
10. Remove the DisqPlay Module cable from the system board.
11. Remove the modem ([pg 24](#)).
12. Remove the CD/DVD drive ([pg 30](#)).
13. Remove the fan assembly ([pg 35](#)).
14. Remove the diskette drive cable from the system board.
15. Remove the battery charger board ([pg 41](#)).
16. Disconnect the speaker assembly cables from the system board ([pg 43](#)).

Continued on the next page.

maintenance & service guide

Presario 1800 Series

Models: XL180, XL181, XL182, XL183, XL185,
and XL190, XL191, XL192

17. Remove the five standoffs from the system board.

Note: The four remaining standoffs located on the system board may be left in place.

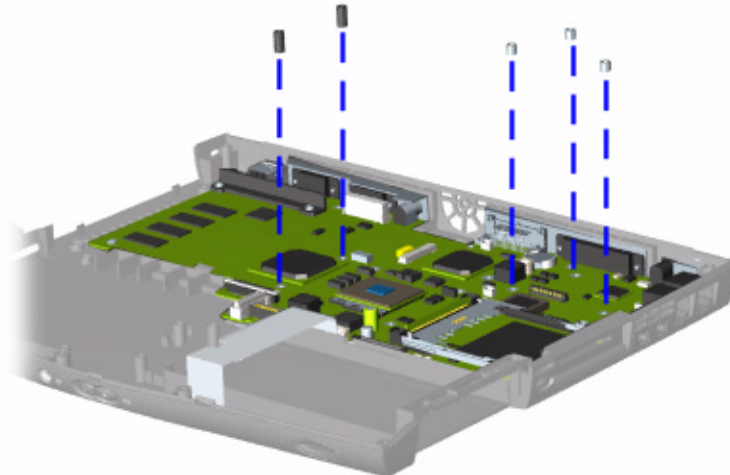

18. Remove the two screws from the CD/DVD drive mounting rail and lift the mounting rail from the system board.

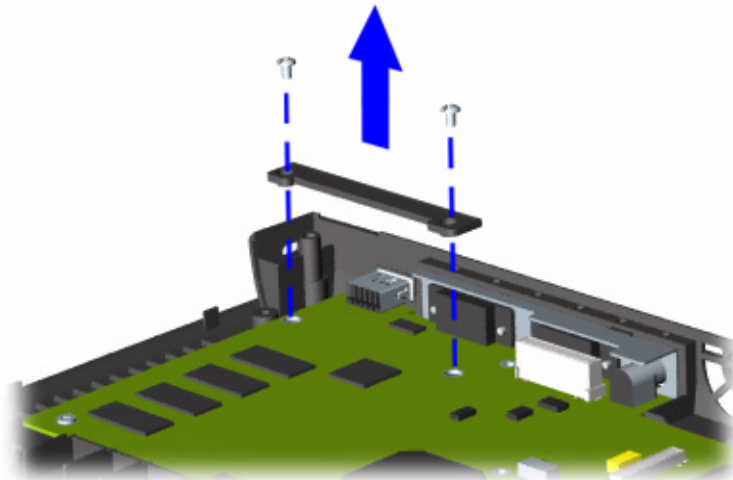

Continued on the next page.

maintenance & service guide

Presario 1800 Series

Models: XL180, XL181, XL182, XL183, XL185,
and XL190, XL191, XL192

19. Remove four screws from the system board.

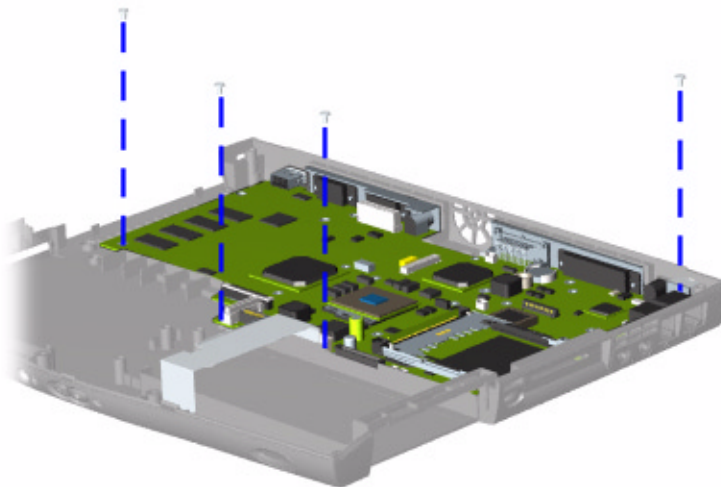

20. Lift up the front and pull forward to remove the system board from the chassis.

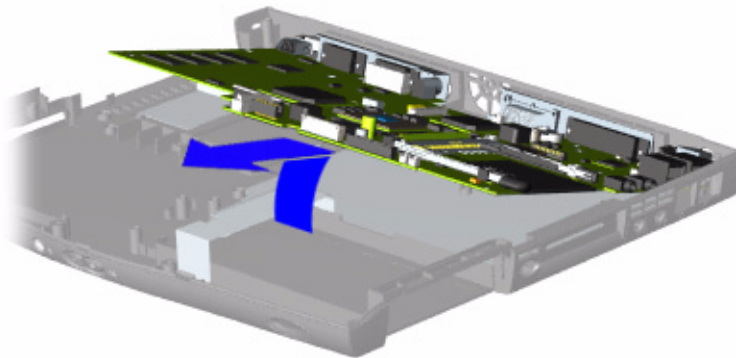

To replace the system board, reverse these procedures.

Important: Before replacing the system board, remove all remaining cables.

maintenance & service guide

Presario 1800 Series
Models: XL180, XL181, XL182, XL183, XL185,
and XL190, XL191, XL192

Removing the Memory Module

To remove the memory module, complete the following steps:

1. Prepare the Notebook for disassembly ([pg 11](#)).
2. Close the display and turn the Notebook over (upside down).
3. Remove the screw from the memory module door.
4. With the front of the Notebook facing you, slide the memory module door to the left and lift.

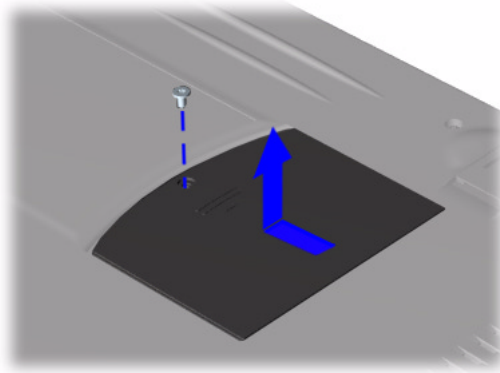

5. ① Pull the side levers to release the module and ② unplug the memory module from the system board.

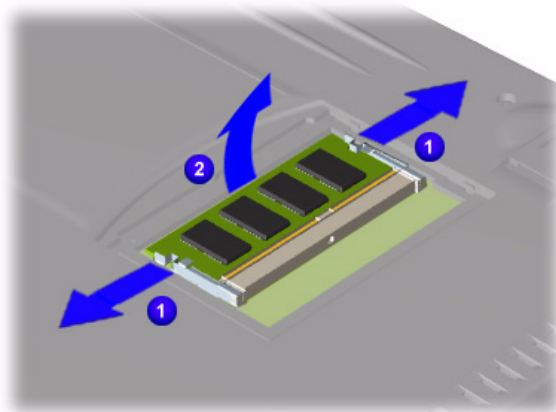

To replace the memory module, reverse these procedures.



maintenance & service guide

Presario 1800 Series

**Models: XL180, XL181, XL182, XL183, XL185,
and XL190, XL191, XL192**

maintenance & service guide

Presario 1800 Series

Models: **XL180, XL181, XL182, XL183, XL185,**
and **XL190, XL191, XL192**

Illustrated Parts Catalog

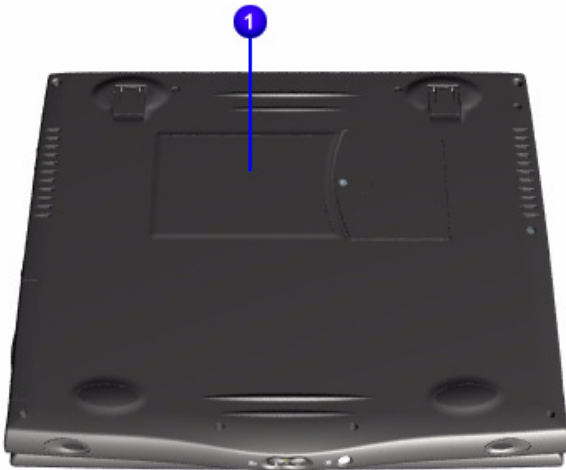

This chapter provides illustrations of the spare parts for Presario 1800XL Series Notebook Computer.

The Notebook serial number is required when customers request information or order spare parts. The serial number ① is located on the underside of the unit.

1.800.AT.COMPAQ

maintenance & service guide

Presario 1800 Series
Models: XL180, XL181, XL182, XL183, XL185,
and XL190, XL191, XL192

System Units

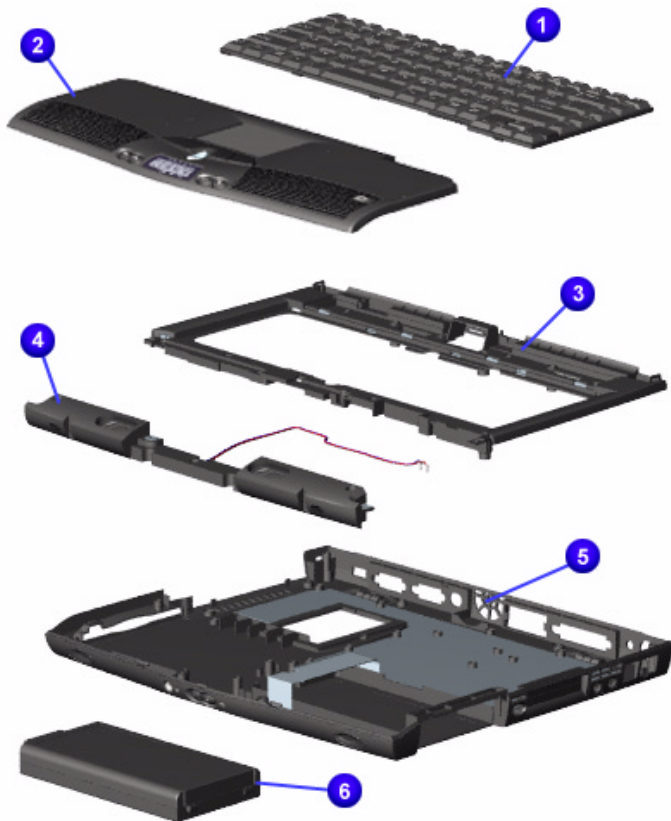

#	Description	Part No.
①	Keyboards	171819-xxx US -001 NL -331 FR -051 IT -061 GR -041 UK -031 138180-xxx UK -031 GR -041 FR -051
②	Palmrest Cover w/ TouchPad and Button Board	138181-001
③	CPU Cover w/ Power Switch	138183-001
④	Speaker Assembly w/Cables	138185-001
⑤	Enclosure Base (I) Enclosure Base (II)	138182-001 171816-001
⑥	Battery Pack Li-Ion Enhanced	138184-001
⑦	Button Board Cover (not shown)	143926-001

maintenance & service guide

Presario 1800 Series

Models: XL180, XL181, XL182, XL183, XL185,
and XL190, XL191, XL192

System Boards

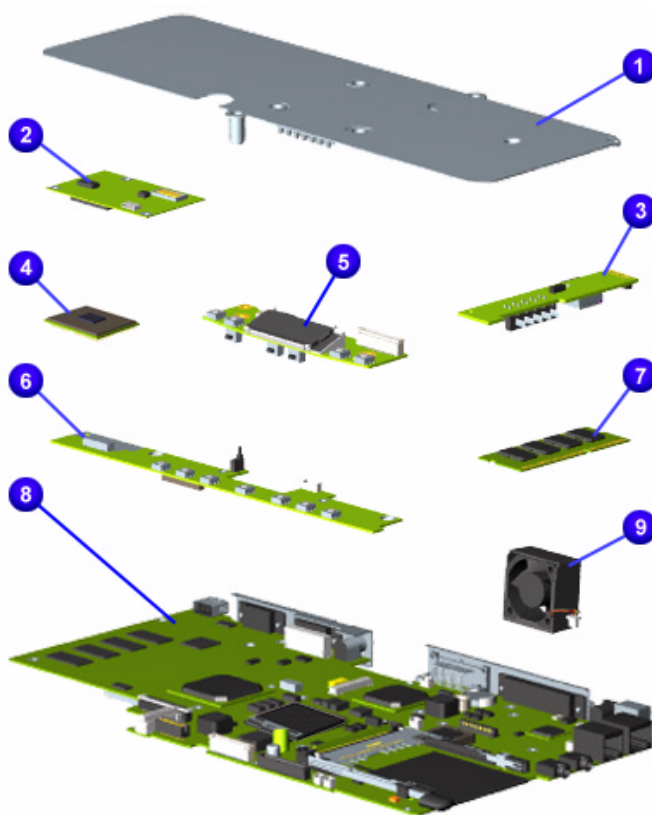

#	Description	Part No.
①	Heatspreader Heatspreader	159698-001 (I) 171817-001 (II)
②	Modem 56K Data/Fax w/o SRAM -US -Int'l	400445-001 143848-001
③	Voltage Converter Board (battery charger)	138177-001 (I) 171815-001 (II)
④	Processors PIII 500MHz 256K Cache MMC-2 uPGA2 PII 600MHz 256K Cache uPGA2 C500MHz 128K Cache	161492-001 173755-001 175319-001 179454-001
⑤	LCD Indicator Module (not shown)	138187-001 (I) 177457-001 (II)
⑥	Internet Button Board	138186-001
⑦	Memory S.O. Dimm 32 MB PC100 64 MB PC100 128 MB PC100 256 MB PC100	122699-001 122700-001 123930-001 175325-001
⑧	System I/O Boards w/ 64 MB SDRAM	171813-001 158804-001 (Mobility-P)
⑨	Fan Assembly	138162-001
⑩	PCI Ethernet 10/100T LAN Card (not shown)	138164-001

maintenance & service guide

Presario 1800 Series
Models: XL180, XL181, XL182, XL183, XL185,
and XL190, XL191, XL192

Display Panel Assembly



Description	Part No.
15.0" TFT/LVDS Display Panel	171814-001 203698-001

Mass Storage Devices

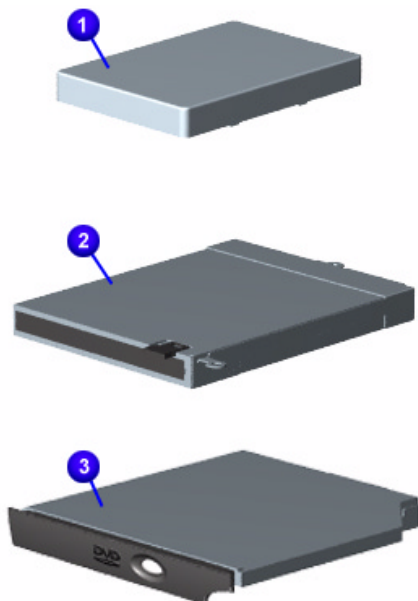

#	Description	Part No.
①	Hard Drives 6.0 GB 12.0 GB	170087-001 170086-001
②	1.44-MB Diskette Drive	138188-001
③	DVD Drives 6X 6X 8X	158165-001 192408-001 175326-001
④	24X CD-ROM Drive (not shown)	143922-001
⑤	CD-R/W Drive (not shown)	171377-001

maintenance & service guide

Presario 1800 Series
Models: XL180, XL181, XL182, XL183, XL185,
and XL190, XL191, XL192

Miscellaneous Cables

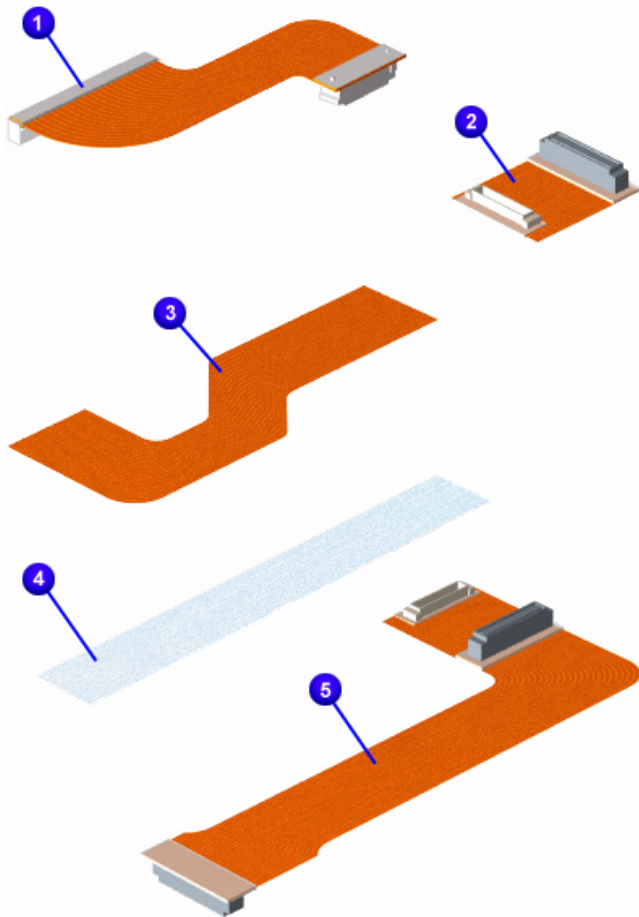

#	Description	Part No.
Miscellaneous Cable Kit*		138189-001
①	Hard Drive Cable	
②	CD/DVD Drive Cable	
③	Diskette Drive Cable	
④	Status Panel Cable	
⑤	DisqPlay LCD Cable	
⑥	Modem Cable (not shown)	
⑦	TouchPad Cable (not shown)	

**Kit includes one of each unless quantity specified.*

maintenance & service guide

Presario 1800 Series

Models: XL180, XL181, XL182, XL183, XL185,
and XL190, XL191, XL192

Miscellaneous Hardware Kit

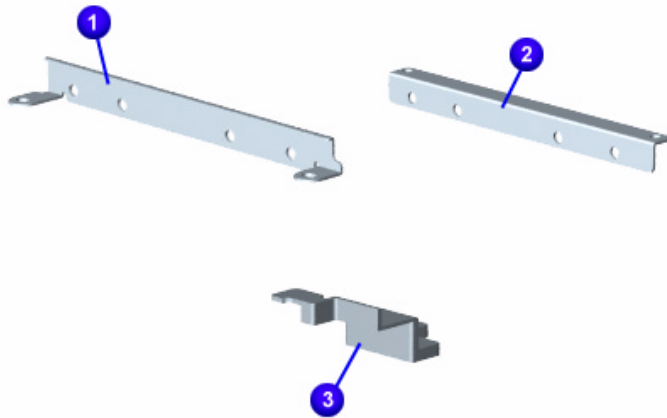

#	Description	Part No.
Miscellaneous Hardware Kit		138160-001
❶	Hard Drive Mounting Bracket (right)	
❷	Hard Drive Mounting Bracket (left)	
❸	Reinforcement Bracket	

maintenance & service guide

Presario 1800 Series

Models: XL180, XL181, XL182, XL183, XL185,
and XL190, XL191, XL192

Miscellaneous Plastics

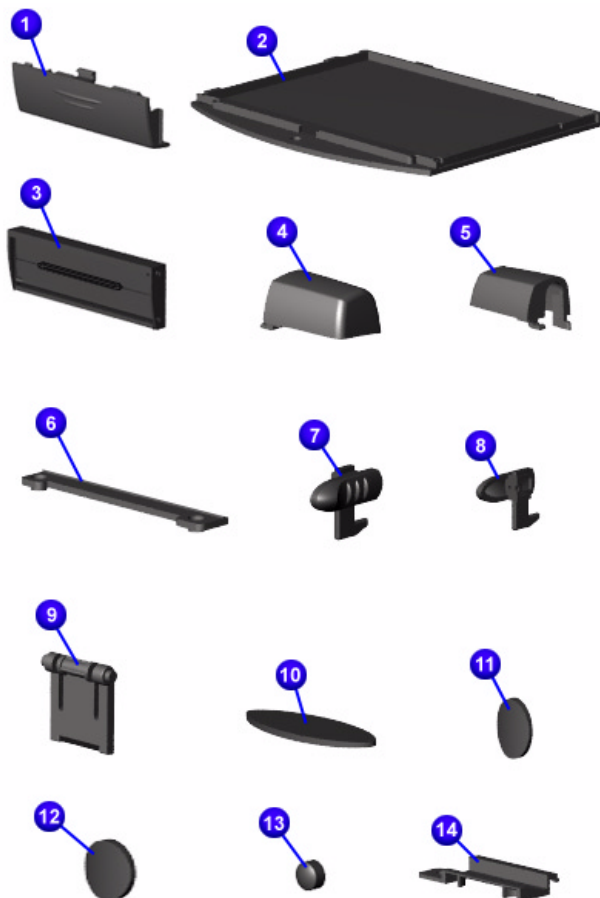

#	Description	Part No.
Miscellaneous Plastics Kit*		138190-001
①	Battery Pack Door	
②	Memory Module Cover	
③	PCMCIA Door	
④	Display Hinge Cover (Right)	
⑤	Display Hinge Cover (Left)	
⑥	CD Drive Guide	
⑦	Latch (right) (qty. 10)	
⑧	Latch (left) (qty. 10)	
⑨	Stand-foot (qty. 10)	
⑩	Rubber Foot (qty. 10)	
⑪	Rubber Plug (side mount for 14.1-in. display) (qty. 10)	
⑫	Rubber Plug side mount for 15.0-in. display) (qty. 10)	
⑬	LCD Rubber Plug (qty. 10)	
⑭	Thin LCD Rubber Plug (14.1-in. Display) (qty. 10)	
⑮	LCD FPC Cover (not shown)	

**Kit includes one of each unless quantity specified.*

maintenance & service guide

Presario 1800 Series

Models: XL180, XL181, XL182, XL183, XL185,
and XL190, XL191, XL192

Miscellaneous Parts

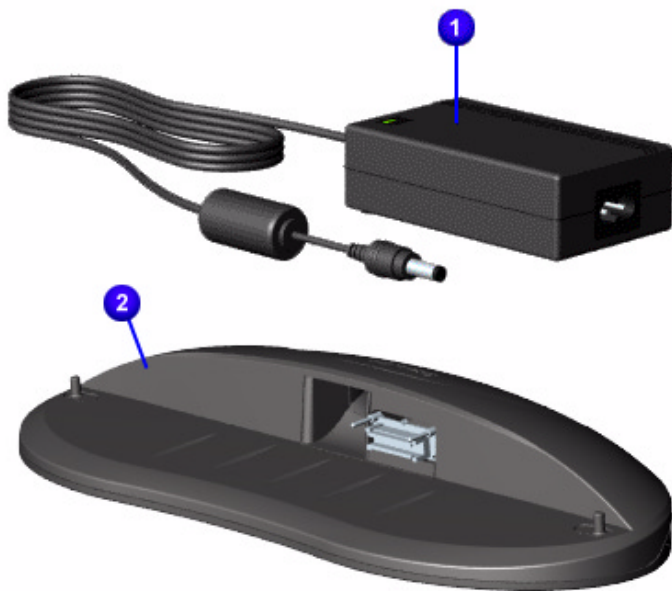

#	Description	Part No.
❶	AC Adapter	298239-001
	APD	164854-001
	60W Slim 3-Wire	180675-001
	60W Slim 2-Wire	180676-001
❷	QuikDock (Port Replicator)	138167-001
❸	Misc. Screw Kit (not shown)	138161-001
❹	Logo Kit (not shown)	169610-001
❺	Return Kit (not shown)	138166-001
❻	AC Power Cords (not shown)	
	N. America	293831-001
	Int'l (3-Wire)	170513-002
	UK (3-Wire)	170513-031
	IT (3-Wire)	170513-061

Documentation and Software

Item	Part No.
Win98 2nd Edition Manual Kit	146642-001
Win2000 Professional Manual Kit	164286-001
Emergency Recovery CD Kit	157296-002
QuickRestore Kit	169300-001
Win98 Reference Guide	117894-003
Features Guide	120223-001

maintenance & service guide

Presario 1800 Series
Models: XL180, XL181, XL182, XL183, XL185,
and XL190, XL191, XL192

Configure To Order (CTO) Parts

Description	Part No.
Display	
14.1" TFT	175324-001
15.0" TFT LVDS	171814-001
15.0" TFT LVDS M D(Special)	203698-001
Processors	
Pentium III 450 w/128 Cache (uPGA2)	175321-001
Pentium III 450 w/256 Cache (uPGA2)	175320-001
Pentium III 500 w/256 Cache (uPGA2)	173755-001
Pentium III 600 w/256 Cache (uPGA2)	175319-001
Pentium III 650 w/256 Cache (uPGA2)	175322-001
Pentium III 700 w/256 Cache (uPGA2)	175323-001
Celeron 500 w/128K Cache (uPGA2)	179454-001
System Memory S.O.DIMM	
32 MB, PC100	122699-001
64 MB, PC100	122700-001
128 MB	123930-001
256 MB	175325-001
System Board I/O w/64 MB SDRAM	171813-001
System Board I/O w/64 MB SDRAM Mobility-P	158804-001
64 MB Module Installed in Slot 1	TBD
64 MB On System Board	
32 MB Module Installed in Slot 1	TBD
64 MB On System Board	
128 MB Module Installed in Slot 1	TBD
64 MB On System Board	
256 MB Module Installed in Slot 1	TBD
CD-ROM/DVD Drives	
8X	175326-001
24X	TBD
CD-R/W Drive	171377-001
24X CD-ROM Drive	TBD
6X-DVD Drive	TBD
8X-DVD Drive	TBD

maintenance & service guide

Presario 1800 Series

Models: XL180, XL181, XL182, XL183, XL185,
and XL190, XL191, XL192

Description	Part No.
Hard Drive	
06.0-GB	TBD
12.0-GB	TBD
18.0-GB	161544-001
30.0-GB	TBD
Port Replicator (Quick Dock)	138167-001
Base Unit Floppy, 64M, 56K, ATI8M-US	TBD
Battery Li-ON 3.6 AHR	177458-001
Software	
Windows 98	TBD
Windows 2000	TBD
Word 2000	TBD
Software Bundle	
FHC Package	TBD
SBE Package	TBD
PRO Package	TBD

Free Manuals Download Website

<http://myh66.com>

<http://usermanuals.us>

<http://www.somanuals.com>

<http://www.4manuals.cc>

<http://www.manual-lib.com>

<http://www.404manual.com>

<http://www.luxmanual.com>

<http://aubethermostatmanual.com>

Golf course search by state

<http://golfingnear.com>

Email search by domain

<http://emailbydomain.com>

Auto manuals search

<http://auto.somanuals.com>

TV manuals search

<http://tv.somanuals.com>