

maintenance & service guide

Presario 1800/1800T Series
Models: XL280, XL380, XL381,
and XL390

Before You Begin

Product Description

Specifications

Pin Assignments

Battery & Power Management

Troubleshooting

Removal & Replacement

Parts Catalog

MSG Index

Welcome to the Maintenance & Service Guide (MSG)



Welcome to the *Maintenance and Service Guide* (MSG) for Compaq Presario 1800XL Series Notebook Computers. This online guide is designed to serve the needs of technicians whose job is to repair Compaq products.

For copyright and trademark information, refer to the [Notice](#) section of this MSG. To locate your unit's serial number, to see symbol conventions, or to view technician's notes, see the [Preface](#). This MSG is updated online as needed.

For comments or questions about the contents of this MSG, [contact Compaq](#).

To report a technical problem, contact your Regional Support Center or IM Help Center.

For help on navigating in this guide, refer to [Using this Guide](#).

1.800.AT.COMPAQ

maintenance & service guide

Presario 1800/1800T Series

**Models: XL280, XL380, XL381,
and XL390**

Using this Guide

To use this guide effectively, refer to the list of bookmarks at the left of the screen. These bookmarks help you navigate through the document quickly and easily. They are accessible from anywhere in the *Maintenance and Service Guide* (MSG).

Viewing a Chapter

Click one of the bookmarks or one of the color-coded bubbles on the [Welcome page](#) to view a chapter of this MSG.

Expanding & Hiding Topics

Click the **+** to expand or show the contents of a section, or click the **-** to hide the contents.

Opening another Chapter

Return to the [Welcome page](#) by clicking the bookmark, **Back to MSG Contents**, and then click the bookmark or color-coded bubble for another chapter.

Printing the MSG

For portable copies of this MSG, you can print single pages, multiple pages, or the entire guide. In the Acrobat Reader, click **File**, and then **Print...** for printing options.

maintenance & service guide

Presario 1800/1800T Series
Models: XL280, XL380, XL381,
and XL390

Before You Begin

Notice

The information in this guide is subject to change without notice.

COMPAQ COMPUTER CORPORATION SHALL NOT BE LIABLE FOR TECHNICAL OR EDITORIAL ERRORS OR OMISSIONS CONTAINED HEREIN, NOR FOR INCIDENTAL OR CONSEQUENTIAL DAMAGES RESULTING FROM THE FURNISHING, PERFORMANCE, OR USE OF THIS MATERIAL.

This guide contains information protected by copyright. No part of this guide may be photocopied or reproduced in any form without prior written consent from Compaq Computer Corporation.

©2000 Compaq Computer Corporation.

All rights reserved. Printed in the U.S.A.

Compaq, Presario 1800 Series, Registered with the U.S. Patent and Trademark Office.

Microsoft, MS-DOS, and Windows are registered trademarks of Microsoft Corporation. Windows 98 and Windows 2000 are trademarks of Microsoft Corporation.

The software described in this guide is furnished under a license agreement or nondisclosure agreement. The software may be used or copied only in accordance with the terms of the agreement.

Product names mentioned herein may be trademarks and/or registered trademarks of their respective companies.

Maintenance and Service Guide

Compaq Presario 1800 Series Notebook Computer

Second Edition (September 2000)

Compaq Computer Corporation

[privacy and legal statement](#)

1.800.AT.COMPAQ

maintenance & service guide

Presario 1800/1800T Series
Models: XL280, XL380, XL381,
and XL390

Preface

The *Maintenance and Service Guide* is a troubleshooting guide for use as a reference when servicing Compaq Presario 1800 Series Notebook Computers.

Compaq Computer Corporation reserves the right to make changes to Compaq Presario 1800 Series Notebooks without notice.

Symbols

The following words and symbols alert you to special messages throughout this guide.

 **WARNING:** Text set off in this manner indicates that a failure to follow the directions in the warning could result in bodily harm or loss of life.

 **CAUTION:** Text set off in this manner indicates that failure to follow the directions in the caution could result in damage to equipment or loss of data.

Important: Text set off in this manner presents clarifying information or specific instructions.

Note: Text set off in this manner presents comments or interesting points of information.

Technician Notes

 **WARNING:** Only authorized technicians trained by Compaq should repair this equipment. All troubleshooting and repair procedures are detailed to allow only subassembly/module-level repair. Because of the complexity of the individual boards and subassemblies, the user should not attempt to make repairs at the component level or modifications to any printed circuit board. Improper repairs can create a safety hazard. Any indications of component replacement or printed circuit board modifications may void any otherwise valid warranty.

maintenance & service guide

Presario 1800/1800T Series

Models: XL280, XL380, XL381,
and XL390

Serial Number

The unit's serial number ❶ is required when requesting information or ordering spare parts. The serial number is located on the underside of the Notebook as shown below.

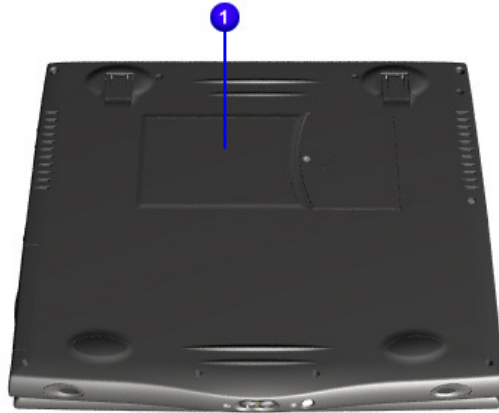

Locating Additional Information

The following documentation is available to support this product:

- Compaq Presario 1800 Series Notebook documentation set
- *Introducing Windows 98 Guide*
- *Introducing Windows 2000 Guide*
- Service Training Guides
- Compaq Service Advisories and Bulletins

maintenance & service guide

Presario 1800/1800T Series

Models: XL280, XL380, XL381,
and XL390

Product Description

This chapter describes the features of each of the Presario 1800XL Series Notebooks. It also provides illustrations of the exterior components unique to these units.



1.800.AT.COMPAQ

maintenance & service guide

Presario 1800/1800T Series
Models: XL280, XL380, XL381,
and XL390

Models and Features

Compaq Presario 1800 Series Portable Computer Models		
Features	XL280*	XL380*
Display	TFT 14.1 in TFT/LVD 15 in	TFT 15.0 in
Processor	600 MHz 256 K Cache 650 MHz 256 K Cache	PIII 700 MHz 256 K Cache
Hard Drive	6.0 GB 12 GB	15.0 GB
CD or DVD Drive	24X 2C CD-ROM 6X DVD 8X DVD	8X DVD
Modem	56 K Data/Fax	56 K PCI Data/Fax
Networking	10/100 TX Integrated Ethernet	10/100 TX Integrated Ethernet
Battery	3.2 Li-ion Enhanced	3.6 Li-ion Enhanced
Memory	64 MB PC100	128 MB PC100

Features	XL381*	XL390*
Display	TFT 15.0 in	TFT 15.0 in
Processor	PIII 700 MHz 256K Cache	PIII 850 MHz 256K Cache
Hard Drive	15 GB	20.0 GB
CD or DVD Drive	8X DVD	8X DVD
Modem	56 K PCI Data/Fax	56 K PCI Data/Fax
Networking	10/100 TX Integrated Ethernet	10/100 TX Integrated Ethernet
Battery	3.6 Li-ion Enhanced	3.6 Li-ion Enhanced
Memory	128 MB PC100	128 MB PC100

**All models have a 3.5" Diskette Drive which uses 1.44 MB Diskettes.*

maintenance & service guide

Presario 1800/1800T Series
Models: XL280, XL380, XL381,
and XL390

Front of Unit

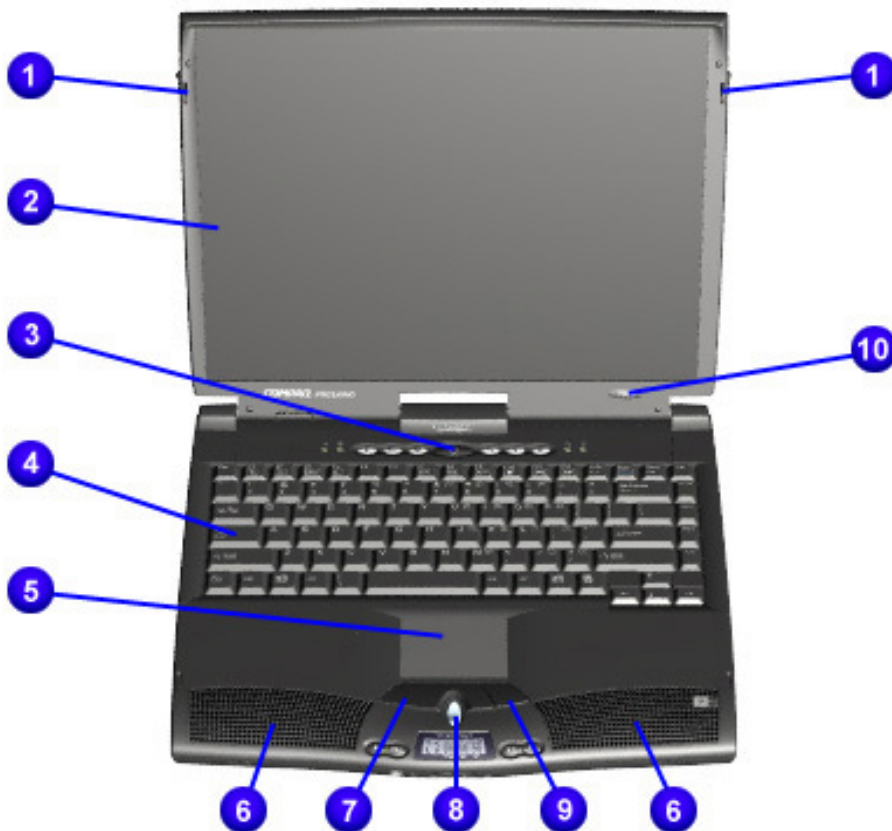

#	Description	#	Description
①	Display Release Latch	⑥	Integrated Speakers
②	Display	⑦	TouchPad Button (Left)
③	Power (On/Off) Button	⑧	Scroll Up/Down Button
④	Keyboard	⑨	TouchPad Button (Right)
⑤	TouchPad	⑩	Model Number

maintenance & service guide

Presario 1800/1800T Series
Models: XL280, XL380, XL381,
and XL390

Internet Zone Buttons and Lights

Model XL280

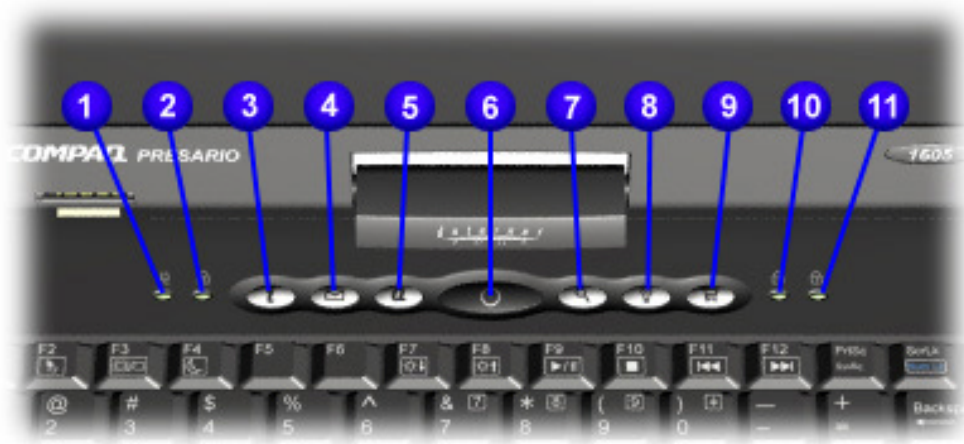

#	Description	#	Description
①	AC Adapter Light	⑦	Instant Search Button
②	Caps Lock Light	⑧	Online Marketplace (U.S./Puerto Rico) Instant Answer (outside the U.S.)
③	Instant Internet Access	⑨	Retail Central (U.S./Puerto Rico) Instant E-Commerce (outside the U.S.)
④	Instant E-mail Access	⑩	Num Lock Light
⑤	My Presario Instant Access	⑪	Scroll Lock Light
⑥	Power Button		

maintenance & service guide

Presario 1800/1800T Series
Models: XL280, XL380, XL381,
and XL390

Model XL3xx

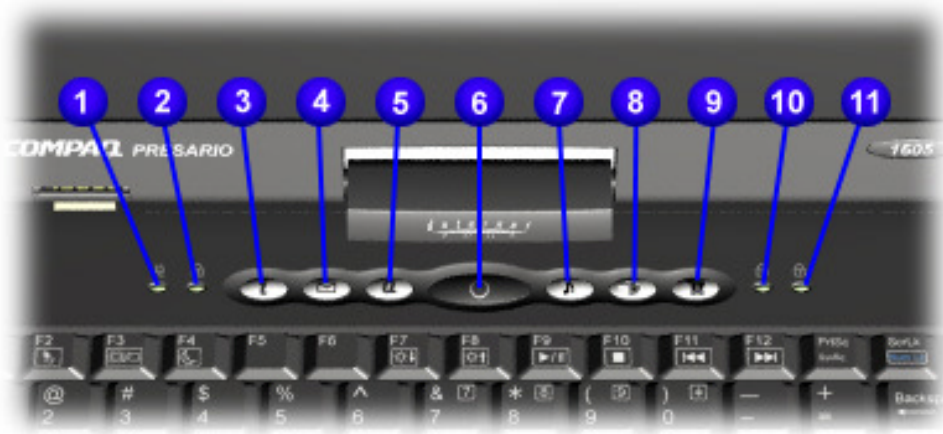

#	Description	#	Description
❶	AC Adapter Light	❷	Digital Audio Button
❷	Caps Lock Light	❸	Entertainment Button
❸	Instant Internet Access	❹	Retail Central Button
❹	Instant E-mail Access	❺	Num Lock Light
❺	My Presario Instant Access	❻	Scroll Lock Light
❻	Power Button		

maintenance & service guide

Presario 1800/1800T Series
Models: XL280, XL380, XL381,
and XL390

Front Bezel Components

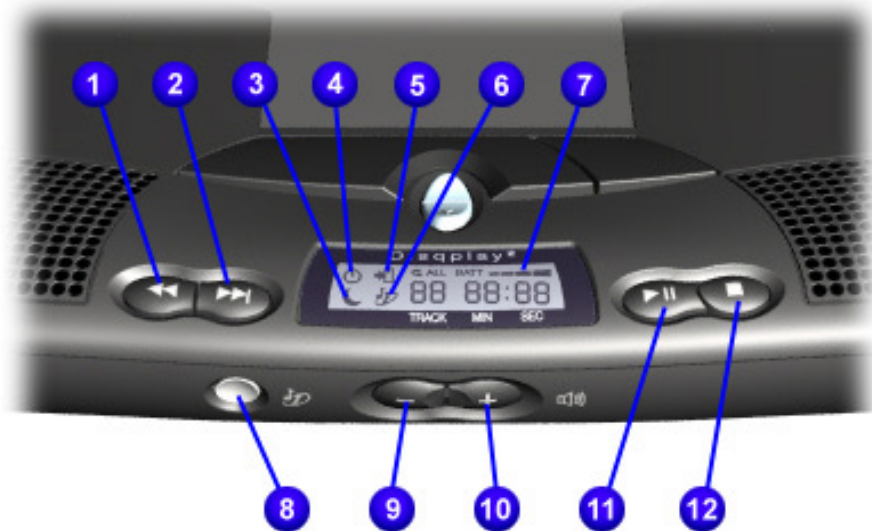

#	Description	#	Description
①	Previous Track Button	⑦	Battery Gauge
②	Next Track Button	⑧	DisqPlay On/Off Button
③	Sleep Status Icon	⑨	Volume Down Button
④	Power Status Icon	⑩	Volume Up Button
⑤	Battery Charging Status Icon	⑪	Play/Pause Button
⑥	DisqPlay Status Icon	⑫	Stop Button

maintenance & service guide

Presario 1800/1800T Series
Models: XL280, XL380, XL381,
and XL390

Left-Side Components

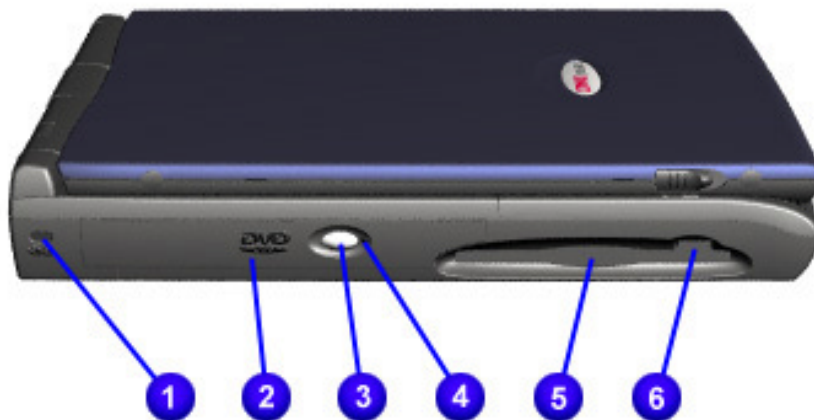

Note: XL3xx models have silver lids.

#	Description	#	Description
❶	Security Slot	❷	CD or DVD Drive
❸	CD/DVD Drive Eject Button	❸	CD or DVD Manual Eject Hole
		❹	Diskette Drive
		❺	Diskette Drive Eject Button

maintenance & service guide

Presario 1800/1800T Series
Models: XL280, XL380, XL381,
and XL390

Right-Side Components

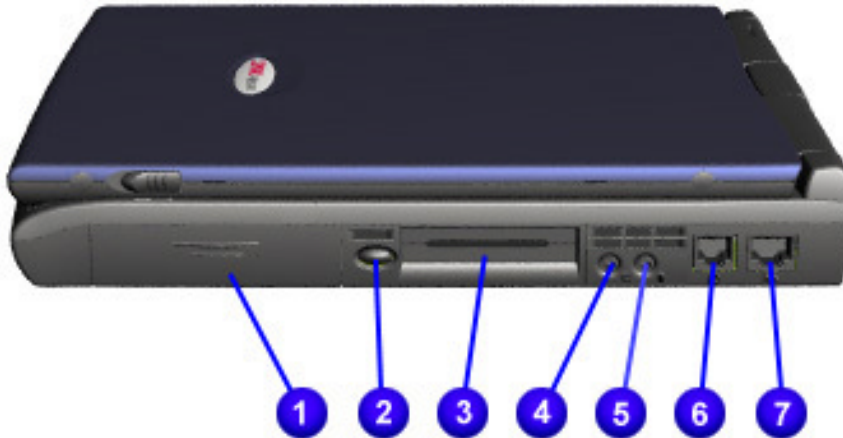

Note: XL3xx models have silver lids.

#	Description	#	Description
①	Battery Compartment	⑤	Microphone Jack
②	PC Card Eject Button	⑥	Modem Port
③	PC Card Slot	⑦	Ethernet Port
④	Headphone Jack		

maintenance & service guide

Presario 1800/1800T Series
Models: XL280, XL380, XL381,
and XL390

Underneath the Unit

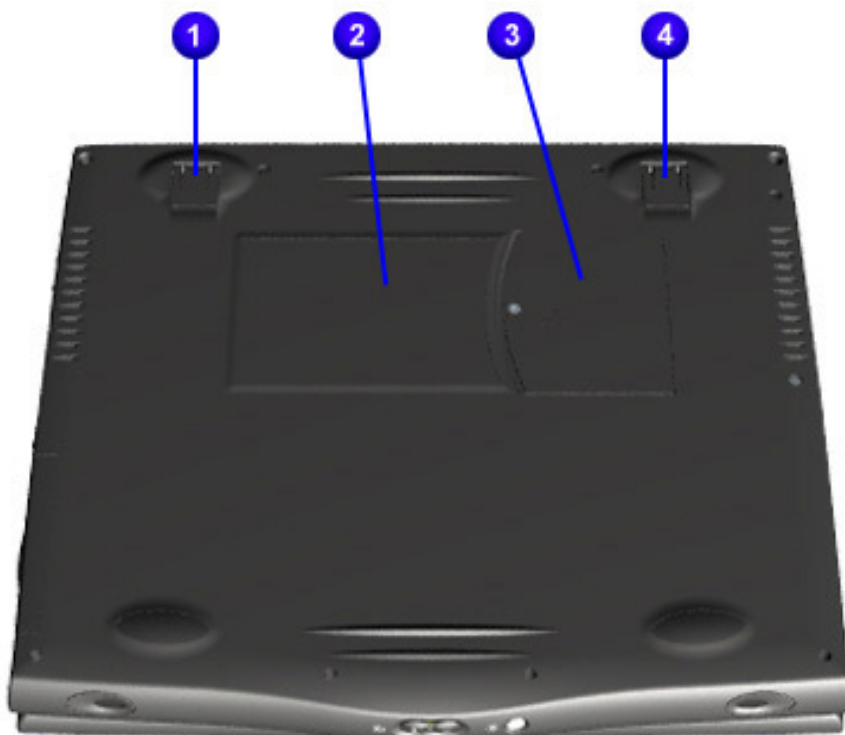

#	Description	#	Description
❶	Pop-Up Foot	❸	Memory Compartment
❷	Serial Number	❹	Pop-Up Foot

maintenance & service guide

Presario 1800/1800T Series
Models: XL280, XL380, XL381,
and XL390

Rear Connectors

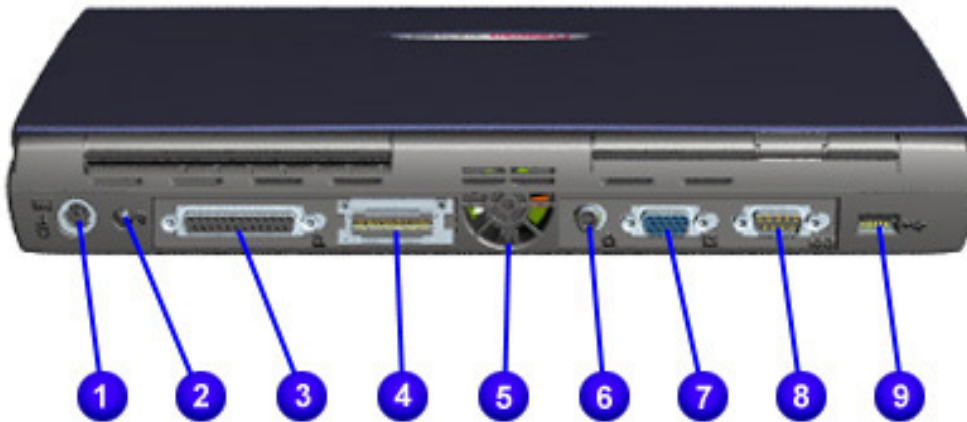

Note: XL3xx models have silver lids.

#	Description	#	Description
①	Keyboard/Mouse Port	⑥	TV-Out Connector
②	AC Adapter Connector	⑦	External Monitor Port
③	Parallel Port	⑧	Serial Ports
④	QuikDock Connector	⑨	Universal Serial Bus Port
⑤	Fan Vent		

maintenance & service guide

Presario 1800/1800T Series
Models: XL280, XL380, XL381,
and XL390

Optional QuikDock

Components

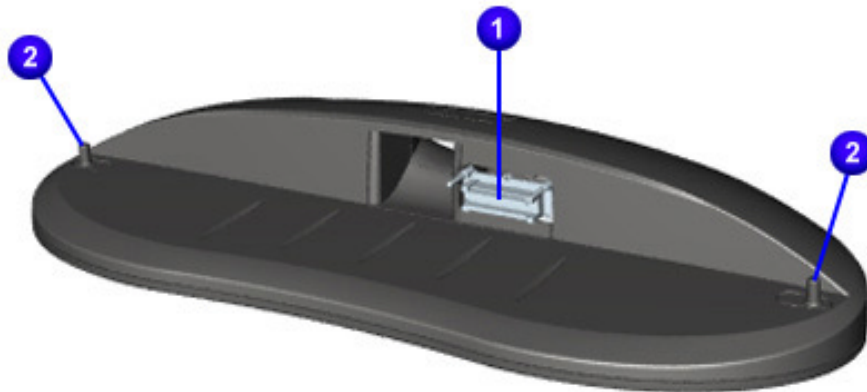

#	Description
①	QuikDock Interface Connector
②	QuikDock Guide Posts

Connectors



#	Description	#	Description	#	Description
①	Universal Serial Bus Port	⑥	Parallel Port	⑪	S-Video Port
②	Universal Serial Bus Port	⑦	Game Port	⑫	TV-Out (Composite Video)
③	Power (AC Adapter) Port	⑧	Serial Port	⑬	Audio-Out
④	Keyboard/Mouse Port	⑨	External Monitor Port		
⑤	Keyboard/Mouse Port	⑩	10/100 TX Ethernet Port		

maintenance & service guide

Presario 1800/1800T Series Models: XL280, XL380, XL381, and XL390

Specifications

Physical and Environmental

Specification	U.S.	Metric
Height	1.63 in.	4.14 cm
Depth	12.99 in.	33.00 cm
Width	11.02 in.	28.00 cm
Weight with 14.1-in. Display with 15.0-in. Display	7.8 lb	3.54 kg
Battery Power Requirements Nominal Operating Maximum Average Peak Operating	Li-ion 3.2 Ahr W @ 14.8 V W @ 14.8 V W @ 14.8 V	Li-ion 3.6 Ahr W @ 14.8 V W @ 14.8 V W @ 14.8 V
AC Power Requirements Operating Voltage Operating Current Operating Frequency Maximum Transient	100-240 V 0.8/0.4 A RMS 47-63 Hz (Meets IEC801-4 & -5) 1kV for 50 ns	
Temperature* Operating Non-operating	41 - 131°F -4 - 140°F	5 - 55 C -20 - 60 C
Relative Humidity (noncondensing) Operating Non-Operating (wb = 38.7 C max)	8% - 90% 5% - 95%	
Altitude Operating Non-operating	-1000 - 10000 ft -1000 - 40000 ft	-300 - 3000 m -300 - 12000 m
Shock Operating Non-operating	150 G / 2 ms (half sine) 700 G / 1 ms (half sine)	
Vibration Operating Non-Operating	1 G 5 G	

**Applicable safety standards specify thermal limits for plastic surfaces. Presario 1800XL Notebooks operate well within this temperature range.*

1.800.AT.COMPAQ

maintenance & service guide

Presario 1800/1800T Series
Models: XL280, XL380, XL381,
and XL390

System Interrupts

Hardware IRQ	System Function	Hardware IRQ	System Function
IRQ 0	System timer	IRQ 10	Available
IRQ 1	Standard 101/102-key or Microsoft Natural Keyboard	IRQ 11	Intel® Pro/100S Mobile LAN on Motherboard
IRQ 2	Programmable Interrupt Controller	IRQ 11	Texas Instruments PCI-1410 CardBus Controller
IRQ 3	Lucent 56K V.90 PCI DF Modem	IRQ 11	ACPI IRQ Holder for PCI IRQ Steering
IRQ 3	ACPI IRQ Holder for PCI IRQ Steering	IRQ 11	Intel® 82371AB/EB PCI to USB Universal Host Controller
IRQ 4	Communications Port (COM1)	IRQ 11	ACPI IRQ Holder for PCI IRQ Steering
IRQ 5	ESS SOLO-1 PCI AudioDrive	IRQ 12	Synaptics PS/2 TouchPad
IRQ 5	ACPI IRQ Holder for PCI IRQ Steering	IRQ 13	Numeric Data Processor
IRQ 5	RAGE Mobility AGP (English)	IRQ 14	Intel® 82371AB/EB PCI Bus Master IDE Controller
IRQ 6	Standard Floppy Disk Controller	IRQ 14	Primary IDE Controller (Dual FIFO)
IRQ 7	Printer Port (LPT1)	IRQ 15	Intel® 82371AB/EB PCI Bus Master IDE Controller
IRQ 8	System CMOS/Real Time Clock	IRQ 15	Secondary IDE Controller (Dual FIFO)
IRQ 9	SCI IRQ used by ACPI Bus		

System DMA

Hardware DMA	System Function
DMA 1	ESS SOLO-1 DOS Emulation
DMA 2	Standard Floppy Disk Controller
DMA 4	Direct Memory Access Controller

maintenance & service guide

Presario 1800/1800T Series
Models: XL280, XL380, XL381,
and XL390

System I/O Addresses

I/O Address	System Function (Shipping Configuration)
0000h-000Fh	Direct Memory Access Controller
0020h-0021h	Programmable Interrupt Controller
0040h-0043h	System Timer
0060h-0060h	Standard 101/102-Key or Microsoft Natural Keyboard
0061h-0061h	System Speaker
0062h-0062h	ACPI Embedded Controller
0064h-0064h	Standard 101/102-Key or Microsoft Natural Keyboard
0066h-0066h	ACPI Embedded Controller
0070h-0071h	System CMOS/Real Time Clock
0081h-008Fh	Direct Memory Controller
00A0h-00A1h	Programmable Interrupt Controller
00C0h-00DFh	Direct Memory Access Controller
00F0h-00FEh	Numeric Data Processor
0170h-0177h	Intel® 82371AB/EB PCI Bus Master IDE Controller
0170h-0177h	Secondary IDE Controller (Dual FIFO)
01F0h-01F7h	Intel® 82371AB/EB PCI Bus Master IDE Controller
01F0h-01F7h	Primary IDE Controller (Dual FIFO)
0200h-0203h	Gameport Joystick
0220h-022Fh	ESS SOLO-1 DOS Emulation
0330h-0331h	ESS SOLO-1 DOS Emulation
0376h-0376h	Secondary IDE Controller (Dual FIFO)
0376h-0376h	Intel® 82371AB/EB PCI Bus Master IDE Controller
0378h-037Fh	Printer Port (LPT1)
0388h-038Bh	ESS SOLO-1 DOS Emulation
03B0h-03BBh	RAGE Mobility AGP (English)
03C0h-03DFh	RAGE Mobilty AGP (English)
03F0h-03F5h	Standard Floppy Disk Controller
03F6h-03F6h	Intel® 82371AB/EB PCI Bus Master IDE Controller

maintenance & service guide

Presario 1800/1800T Series
Models: XL280, XL380, XL381,
and XL390

I/O Address	System Function (Shipping Configuration)
03F6h-03F6h	Primary IDE Controller (Dual FIFO)
03F7h-03F7h	Standard Floppy Disk Controller
03F8h-03FFh	Communications Port (COM1)
04D0h-04D1h	Motherboard Resources
0CF8h-0CFFh	PCI Bus
1000h-10FFh	Lucent 56K V.90 PCI DF Modem
1400h-143Fh	ESS SOLO-1 PCI AudioDrive
1440h-147Fh	Intel® PRO/100 S Mobile LAN on Motherboard
1480h-149Fh	Intel® 82371AB/EB PCI to USB Universal Host Controller
14A0h-14A7h	Primary IDE Controller (Dual FIFO)
14A0h-14AFh	Intel® 82371AB/EB PCI Bus Master IDE Controller
14A8h-14AFh	Secondary IDE Controller (Dual FIFO)
14B0h-14BFh	ESS SOLO-1 PCI AudioDrive
14C0h-14CFh	ESS SOLO-1 PCI AudioDrive
14D0h-14D7h	Lucent 56K V.90 PCI DF Modem
14D8h-14DBh	ESS SOLO-1 PCI AudioDrive
14DCh-14DFh	ESS SOLO-1 PCI AudioDrive
2180h-218Fh	Motherboard Resources
8000h-803Fh	Motherboard Resources
9000h-9FFFh	Intel® 82443BX Pentium® II Processor to AGP Controller
9000h-90FFh	RAGE Mobility AGP (English)

maintenance & service guide

Presario 1800/1800T Series
Models: XL280, XL380, XL381,
and XL390

System Memory Catalog

Memory Address	System Function
000A0000h-000AFFFFh	RAGE Mobility-M1 AGP (English)
000B0000h-000BFFFFh	RAGE Mobility-M1 AGP (English)
000C0000h-000CFFFFh	RAGE Mobility-M1 AGP (English)
04000000h-04000FFFh	Texas Instruments PCI-1410 CardBus Controller
04001000h-04001FFFh	Intel® PRO/100 S Mobile LAN on Motherboard
04100000h-F041FFFFh	Intel® PRO/100 S Mobile LAN on Motherboard
F4101000h-F41010FFFh	Lucent 56K V.90 PCI DF Modem
F4200000h-F4200FFFh	RAGE Mobility-M3 AGP (English)
F4200000h-F5FFFFFFh	Intel® 82443BX Pentium® II Processor to AGP Controller
F4220000h-F423FFFFh	RAGE Mobility AGP (English)
F5000000h-F5FFFFFFh	RAGE Mobility AGP (English)
F8000000h-FBFFFFFFh	Intel® 82443BX Pentium® II Processor to PCI bridge
FFF80000h-FFFFFFFFh	Motherboard Resources

Memory Expansion

System Memory	Expansion Board Memory	Total Memory
64 MB	None	64 MB
64 MB	32 MB	96 MB
64 MB	64 MB	128 MB
64 MB	128 MB	192 MB
64 MB	256 MB	320 MB

maintenance & service guide

Presario 1800/1800T Series
Models: XL280, XL380, XL381,
and XL390

Display

Specification	15.0-in. TFT with LVDS	15.0-in. TFT/SXGA with LVDS	14.1-in. TFT with LVDS
Unit Height	9.48 in. (24.05 cm)	9.48 in. (24.05 cm)	8.92 in. (22.65 cm)
Unit Width	12.43 in. (31.55 cm)	12.43 in. (31.55 cm)	11.76 in. (29.85 cm)
Display Height	8.99 in. (22.81 cm)	8.99 in. (22.81 cm)	8.44 in. (21.43 cm)
Display Width	11.98 in. (30.41 cm)	11.98 in. (30.41 cm)	11.26 in. (28.57 cm)
Weight	24.36 oz (690 g)	24.36 oz (690 g)	19.94 oz (565 g)
Contrast Ratio	150:1		150:1
Brightness	120 cd/mm ³	120 cd/mm ³	120 cd/mm ³
Response Time	50 ms or less		50 ms or less
Refresh Rate	60 Hz or better	60 Hz or better	60 Hz or better
Power	4.5 mA or less	4.5 mA or less	4.5 mA or less

Diskette Drive

Specification	Value
Capacity per Diskette (High/Low)	1.44 MB/720 KB
Diskette Size	3.5 in.
Number of LED Indicators (Read/Write)	0
Number of Drives Supported	1
Drive Rotation (rpm)	300
Transfer Rate (Kbps)	500
Bytes per Sector	512
Sectors per Track (High/Low)	18/9
Tracks per Side (High/Low)	80

maintenance & service guide

Presario 1800/1800T Series Models: XL280, XL380, XL381, and XL390

Hard Drive

Specification	6.0 GB	10.0 GB	12.0 GB
Drive Type	Ultra DMA	Ultra DMA	Ultra DMA
Height	9.5 mm	9.5 mm	9.5 mm
Width*	69.85-70.0 mm	69.85-70.0 mm	70.0 mm
Depth	100.0 mm	100.0 mm	100.0 mm
Weight*	92-98 g	94-98 g	92-98 g
Seek Times* (typical):			
Read/Write (incl. settling)	13 ms	13 ms	13 ms
Single Track	3 ms	1.5-3 ms	3 ms
Full Stroke	24 ms	23-24 ms	24 ms
Transfer Rate at Interface			
Ultra DMA mode (max)	66.6 MB/s	66.6 MB/s	66.6 MB/s
Rotational Speed	4200 rpm	4200 rpm	4200 rpm
Interface*	ATA-2/3/4/5	ATA-2/3/4/5	ATA-2/3/4/5
Buffer Size*	256-512 KB	512-1024 KB	512 KB

Specification	15.0 GB	20.0 GB	32.0 GB
Drive Type	Ultra DMA	Ultra DMA	Ultra DMA
Height	9.5 mm	9.5 mm	9.5 mm
Width*	70.0 mm	69.85-70.0 mm	70.0 mm
Depth	100.0 mm	100.0 mm	100.0 mm
Weight*	92-98 g	99.0 g	99.0 g
Seek Times* (typical):			
Read/Write (incl. settling)	13 ms	12.0-13.0 ms	12.0 ms
Single Track	3.0 ms	2.5-3.0 ms	2.5 ms
Full Stroke	24 ms	23.0-24.0 ms	23.0 ms
Transfer Rate at Interface			
Ultra DMA mode (max)	66.6 MB/s	66.6 MB/s	66.6 MB/s
Rotational Speed	4200 rpm	4200 rpm	5411
Interface*	ATA-2/3/4/5	ATA-2/3/4/5	ATA-5
Buffer*	512 KB	1024-2048 KB	2048 KB

**Specifications vary by vendor/brand.*

maintenance & service guide

Presario 1800/1800T Series Models: XL280, XL380, XL381, and XL390

Battery Pack

Specification	3.2 AHr Li-ion	3.6 AHr Li-ion
Type	Lithium Ion Enhanced	Lithium Ion Enhanced
Height	0.8 in. (20.3 mm)	0.8 in. (20.3 mm)
Length	5.7 in. (145 mm)	5.7 in. (145 mm)
Width	3.1 in. (78.7 mm)	3.1 in. (78.7 mm)
Weight	0.90 lb (408.2 g)	0.90 lb (408.2 g)
Operating Lifetime	>3 hr*	>3 hr*
Nominal Open Circuit Voltage	14.4 V	14.4 V
Capacity	3.2 Ahr	3.6 Ahr
Power	43.2 WH	43.2 WH
Temperature Requirements		
Operating	0-50 C	0-50 C
Non-operating	-20-60 C	-20-60 C
Charging	5-45 C	5-45 C

**The battery operating lifetime depends on your power management settings, system components, options, and applications.*

CD/CD-RW/DVD Drive

Specification	6X DVD	8X DVD	CD-RW	24X CD-ROM
Dimensions	128 x 129 x 12.7 mm	128 x 126.1 x 12.7 mm	128 x 129 x 12.7 mm	128 x 129 x 12.7 mm
Weight	280 g	265-270 g	300 g	180-270 g
Rotational Speed Approx. *		1200-4670 rpm	4200 rpm (CD)	4225-5200 rpm
Sustained Data Transfer Rate (typical) *		4463-10820 KB/s	2100 KB/s	1545-3600 KB/s
Random Access Time (Avg.)	140 ms	90-100 ms	150 ms	90-180 ms
Spin Up time	<15 s	2.0-2.5 s	<10 s	2.7-2.8 s
Data Buffer Capacity	512 KB	128 KB	2 MB	128 KB

**Specifications vary by vendor/brand.*

maintenance & service guide

Presario 1800/1800T Series Models: XL280, XL380, XL381, and XL390

Pin Assignments

This chapter provides the pin assignments for Presario 1800XL Series Notebook connectors. For additional information about connectors or external ports, refer to [Rear Connectors](#) and [QuikDock Connectors](#).

Note: The signals in all tables of this appendix are considered active high unless otherwise indicated by an asterisk (*).

Parallel Connector

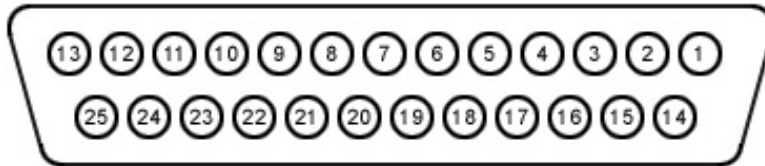

Pin	Signal	Pin	Signal
1	Strobe*	10	Acknowledge*
2	Data Bit 0	11	Busy
3	Data Bit 1	12	Paper Out
4	Data Bit 2	13	Select
5	Data Bit 3	14	Auto Line Feed*
6	Data Bit 4	15	Error*
7	Data Bit 5	16	Initialize Printer*
8	Data Bit 6	17	Select In*
9	Data Bit 7	18-25	Signal Ground

*Signal is active low.

1.800.AT.COMPAQ

maintenance & service guide

Presario 1800/1800T Series
Models: XL280, XL380, XL381,
and XL390

TV-Out (Composite Video) Connector

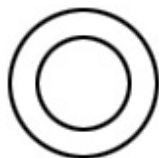

Pin	Signal
1	Ground
2	Composite
3	Ground

Universal Serial Bus (USB) Connector

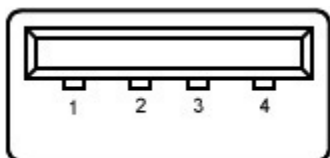

Pin	Signal	Pin	Signal
1	+5V	3	Data +
2	Data -	4	Ground

Keyboard/Mouse Connector



Pin	Signal	Pin	Signal
1	Data 1	4	+5 V
2	Data 2	5	Clock 1
3	Ground	6	Clock 2

maintenance & service guide

Presario 1800/1800T Series
Models: XL280, XL380, XL381,
and XL390

Modem Connector

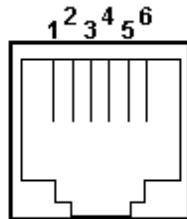

Pin	Signal	Pin	Signal
1	Unused	4	Unused
2	Tip	5	Unused
3	Ring	6	Unused

External VGA Monitor Connector

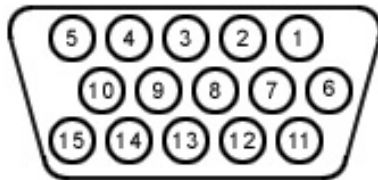

Pin	Signal	Pin	Signal
1	Red Analog	9	+5V
2	Green Analog	10	Ground
3	Blue Analog	11	Monitor Detect
4	Not connected	12	DDC2B Data
5	Ground	13	Horizontal Sync
6	Ground Analog	14	Vertical Sync
7	Ground Analog	15	DDC2B Clock
8	Ground Analog		

maintenance & service guide

Presario 1800/1800T Series
Models: XL280, XL380, XL381,
and XL390

Game Port Connector

Note: the game port connector is available only on the optional QuikDock device.

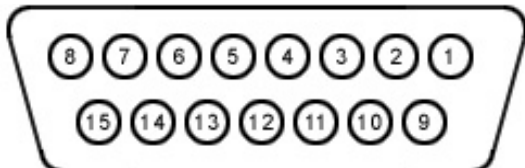

Pin	Signal	Pin	Signal
1	+5V	9	+5V
2	SWA	10	SWC
3	RBTA	11	RBTC
4	GND	12	RMSO
5	GND	13	RBTD
6	RBTB	14	SWD
7	SWB	15	RMSI
8	+5V		

Serial Connector

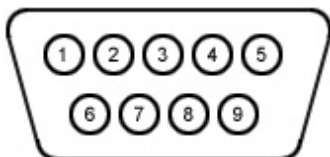

Pin	Signal	Pin	Signal
1	Carrier Detect	6	Data Set Ready
2	Receive Data	7	Ready to Send
3	Transmit Data	8	Clear to Send
4	Data Terminal Ready	9	Ring Indicator
5	Signal Ground	5	Signal Ground

maintenance & service guide

Presario 1800/1800T Series
Models: XL280, XL380, XL381,
and XL390

QuikDock Connector

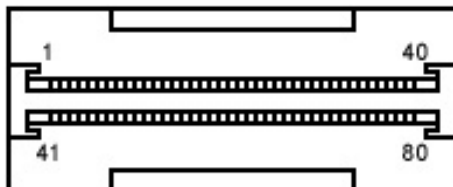

Pin	Signal	Pin	Signal	Pin	Signal	Pin	Signal
1	Adapter Power	22	Serial Port DCD	43	Keyboard Clock	64	Reserved
2	Adapter Power	23	Serial Port DSR	44	Keyboard Data	65	Head-phone Sense
3	Adapter Power	24	Serial Port TXD	45	Mouse Clock	66	USB Power
4	Adapter Power	25	Serial Port RTS	46	Mouse Data	67	USB Power
5	Adapter Power	26	Monitor DDC	47	Lp Indicator	68	USB Power
6	Adapter Power	27	Monitor DDC	48	Lp Paper End	69	USB Power
7	Not Connected	28	Monitor Indicator	49	Lp Init	70	USB A-
8	Printer Data 0	29	V. SYNC	50	Lp Busy	71	USB A+
9	Printer Data 1	30	Ground	51	Lp Error	72	USB B-
10	Printer Data 2	31	H. SYNC	52	Lp Acknowledge	73	USB B+
11	Printer Data 3	32	Ground	53	Lp AutoFeed	74	5V
12	Printer Data 4	33	Blue	54	Lp Strobe	75	5V
13	Printer Data 5	34	Ground	55	Joystick Data A	76	Line-Out Left
14	Printer Data 6	35	Green	56	Joystick Data B	77	S-Video SYR
15	Printer Data 7	36	Ground	57	Joystick Data C	78	Ground
16	Lp Select	37	Red	58	Joystick Data D	79	S-Video SCG
17	QuikDock Indicator	38	Ground	59	Switch A	80	Ground
18	Serial Port RXD	39	Composite TV-Out	60	Switch B		
19	Serial Port RI	40	Line-Out Right	61	Switch C		
20	Serial Port DTR	41	Line-Out Present	62	Switch D		
21	Serial Port CTS	42	Reserved	63	Reserved		

maintenance & service guide

Presario 1800/1800T Series
Models: XL280, XL380, XL381,
and XL390

Battery and Power Management

This chapter describes power management and proper battery operating practices for Presario 1800XL Series Notebooks. These practices include conservation of AC power and extending the operating life of the battery. The following sections also outline proper methods to start and shut down the Notebook in various situations.

Power Modes

Presario 1800XL Series Notebooks have three levels of low power: *Hibernation*, *Standby*, and *Off*.

Hibernation

Hibernation mode helps conserve battery life and protect data. The Notebook automatically enters Hibernation mode when the battery has little power left or when the Notebook (operating on battery power) is in Standby mode for more than one hour. As the Notebook enters Hibernation, it automatically stores the contents of its memory to the hard drive before shutdown. When the Notebook wakes from Hibernation, it returns to its former state.

Note: When the Notebook enters or wakes from Hibernation mode, a Progress window is displayed.

To activate Hibernation mode, press the **Power**  button once.

To resume from Hibernation mode, press the **Power**  button once.

Standby

Standby is a low-power mode, also referred to as *Sleep* mode. The Notebook maintains system information and open files while in Standby mode. Selecting Standby instead of turning off the Notebook when you have finished working has two advantages: 1. It allows the Notebook to wake up faster; 2. It saves more power than the Active-On mode.

 **CAUTION:** Unsaved information is lost if the Notebook is turned off prior to system wake-up, or if a power loss occurs while using the AC adapter.

To activate Standby/Sleep mode, press **Fn+F4** or click **Start**, click **Shut Down**, and then select **Standby** from the options.

To resume from Standby/Sleep mode, press any key.

1.800.AT.COMPAQ

maintenance & service guide

Presario 1800/1800T Series Models: XL280, XL380, XL381, and XL390

Full Off

Off mode consumes no power. However, the battery charges while the Notebook is in Off mode if the battery is installed and the Notebook remains plugged into external AC power.

Note: Unsaved information is lost if the Notebook is shut down without saving the data.

To activate Off mode, click the **Start** button on the Windows taskbar, click **Shut Down**, and then select **Shut down** from the options.







To restart the Notebook from Off mode, press the **Power**  button once.



CAUTION: The Notebook must be in Off mode (completely shut down) when installing or replacing components. Follow the instructions for putting the Notebook into Off mode, unplug it from the outlet, and [remove the battery pack](#) before servicing any parts.

Summary of Power Modes

The following table outlines the procedures for entering and exiting the various power modes and the external indicators for each mode.

	Standby Mode	Hibernation Mode	Off Mode
Automatic Activation	15 minutes if using battery power* (preset default)	When battery is low or after 1 hour of Standby* (preset default)	Standard Shutdown: click Start on the Windows taskbar, Shut Down , and then select shut down .
Manual Activation	Press Fn+F4 key combination or click Start on the Windows taskbar, Shut Down , and then Standby .	Press the Power  button once.	Manual Shutdown**: Press and hold down the Power  button for 4 sec. OR Press Fn+Power (press and hold the Fn key then press the Power button).
Resume/Exit	Press any key.	Press the Power  button once.	Press the Power  button once.
Indicators	Power light flashes and Moon  icon appears on status display.	Power light is off, screen is blank, and Power  icon does not appear on status display.	Power light is off, screen is blank, and Power  icon does not appear on status display.

*The Notebook will not automatically enter Standby or Hibernation mode if using AC power.

****Important:** The Manual Shutdown procedures are not recommended unless the Standard Shutdown is unsuccessful.

maintenance & service guide

Presario 1800/1800T Series
Models: XL280, XL380, XL381,
and XL390

Power Settings

Power management modes can be initiated based on the amount of time passed since the last system activity. System activity includes keyboard strokes, mouse movement, CD/DVD playback, or modem use.

Power Schemes

Different patterns of Notebook use determine the level of power management needed. Power management settings can be selected using several predefined *Power Schemes*. To access these options, select **Power Management** on the **Control Panel**, then click the **Power Schemes** tab. The default Power Schemes are *Home/Office Desk*, *Portable/Laptop*, and *Always On*. Power Schemes can also be customized by changing the following options:

- **System Standby:** length of inactivity before the Notebook goes into Standby mode.
- **Turn Off Monitor:** length of inactivity before the screen times out and goes blank.
- **Turn Off Hard Disks:** length of inactivity before the hard drive goes into low-power mode.
- **Hibernate:** length of inactivity before the Notebook goes into Hibernation mode.

Important: The setting for the Hard Disk must be less than or equal to the setting for the System. If the Notebook is on a network, Compaq recommends that System Standby be set to Never.

The following table shows the default settings for each Power Scheme.

Power Scheme	Always On	Portable/ Laptop	Home/ Office Desk
AC Power			
System Standby	Never	Never	Never
Turn OFF Monitor	20 minutes	3 hours	20 minutes
Turn OFF Hard Disks	Never	15 minutes	Never
Hibernate	Never	Never	Never
Battery Power			
System Standby	Never	15 minutes	5 minutes
Turn OFF Monitor	15 minutes	Never	5 minutes
Turn OFF Hard Disks	30 minutes	10 minutes	10 minutes
Hibernate	Never	1 hour	20 minutes

maintenance & service guide

Presario 1800/1800T Series
Models: XL280, XL380, XL381,
and XL390

Alarms

The Notebook can be set to alarm when the battery power level is reduced or when it reaches a critically low level. The Notebook can also be set to enter a low-power mode when the battery reaches a specific power level.

 **CAUTION:** The settings on the Alarms tab are preset for the Notebook to run at optimum efficiency. Changing any of these settings may cause the Notebook to function improperly. It is recommended that these settings be left at their default values.

Default Alarm Settings		
Setting	Low Battery	Critical Battery
Alarm power level	10%	0%
Notification	Sound	No Action
Power Mode	No Action	Hibernation
Active	Enabled	Enabled

SpeedStep Technology

SpeedStep Technology features several options for processor response to low-power conditions. These include the following settings:



- **Maximum Performance:** always at high speed
- **Battery Optimized:** always at low speed
- **Reversed:** opposite recommended
- **Recommended:** performance on AC, Battery-Optimized on Battery
- **Disabled:** no run-time support, high speed



SpeedStep options can be accessed in three ways:

- Access **F10** Setup during startup and select the **Advanced** screen.
- Click the **Start>Settings>Control Panel>Power Options>Intel(R) SpeedStep^(TM) technology** tab.
- Double-click the Flag icon on the Windows taskbar to open the **Intel(R) SpeedStep^(TM) technology** dialog box.

Presario 1800/1800T Series
Models: XL280, XL380, XL381,
and XL390

Rebooting After a Lockup

To reboot the Notebook when the keyboard is frozen or the screen is locked, press and hold down the **Power**  button for at least four seconds; this causes the Notebook to shutdown. Then, restart the Notebook with a single press of the **Power**  button.

If the Notebook still does not recover, press the **Power**  button and hold for four seconds to shut it down, then remove the battery and unplug the AC power for at least 30 seconds. Reinsert the battery or reconnect AC power and press the **Power**  button once to reboot.

Recovering From a Loss of Electrical Power

Loss of electrical power causes the Notebook to turn off automatically. This may cause loss of data because the Microsoft Windows operating system is not able to close all files and programs properly.

Loss of power may be caused by one of the following:

- Electrical power service is interrupted.
- The power cord is accidentally disconnected.

If power surges or sags, the display and status lights may flicker, and the Notebook may automatically restart. If an improper shutdown occurs, the Microsoft Windows utility program, ScanDisk, runs automatically once power is restored. ScanDisk determines whether the improper shutdown caused any errors on the hard disk. These errors may occur if the Microsoft Windows operating system is not able to close all files properly before the shutdown. If no errors are found, the restart process continues. If ScanDisk does detect errors, follow the instructions on the screen to continue the restart process. Work that was not saved before the loss of power or shutdown may be lost.

If a power failure occurs, or the power cord disconnects while the Notebook is turned on, turn it off until normal service is restored. The next time the Notebook is turned on, ScanDisk may run to check the hard disk for errors caused by improper shutdown.

Presario 1800/1800T Series
Models: XL280, XL380, XL381,
and XL390

Increasing Battery Pack Operating Time

Battery pack operating life is affected by several variables. To avoid unnecessary replacement, consider the following when determining how long a charged battery pack should last:

- Power conservation settings
- Hardware configuration
- Software applications
- Installed options
- Display brightness
- Hard drive usage
- Changes in operating temperatures
- Type and number of installed PC Cards

Note: Power consumption requirements for PC cards vary widely. Some cards drain the battery pack very rapidly.

Battery pack operating life can be increased by as much as 50 percent by controlling the energy required by the Notebook and the energy stored in the battery pack.

Minimizing the Energy Required

To minimize the energy required by the Notebook, follow these guidelines:

- Set the power conservation levels in the Power Management utility to **Maximum**.
- Customize the time-out value to work more efficiently with the applications. The length of battery life depends on the values selected.

Maximizing the Energy Stored

To maximize the energy stored in the battery pack, follow these guidelines:

- [Condition the battery pack](#) at least every 30 days to improve overall battery performance.
- Keep a battery pack in the Notebook when using it with AC power to supply the battery pack with a constant trickle charge.
- Store the battery pack in a cool, dry place when not in use.

maintenance & service guide

Presario 1800/1800T Series
Models: XL280, XL380, XL381,
and XL390

Conditioning a Battery Pack

 **CAUTION:** To avoid losing data, Make sure that all information is saved before completely discharging a battery pack.

To condition a battery pack, complete the following steps:

1. Plug in the AC adapter and allow the battery to charge until the fast charge arrow on the status display disappears. The battery gauge may read 100% for a period of time before the arrow disappears.

Note: Do not unplug the AC adapter until the arrow disappears.

2. Unplug the AC adapter and allow the battery to drain until the Notebook enters Hibernation mode. The Notebook can be used normally during this process.

Note: If the AC adapter is connected while the battery is draining, the process must be repeated beginning with step 1.

The battery is now reconditioned. Plug in the AC adapter and begin using the Notebook.

The table below shows typical battery charging times.

Li-ion Enhanced Battery Pack	Charge Time
Computer On Line	4.75 hours
Computer Off Line	3.00 hours

Disposing of a Used Battery Pack

In the interests of safeguarding our environment, Compaq Computer Corporation recommends that nickel metal hydride (NiMH) and lithium-ion (Li-ion) battery packs be recycled. Battery packs should be handled in accordance with country, state, province, or local regulations.

 **CAUTION:** Never attempt to open or service a battery pack. Opening a battery pack not only damages the pack and makes it unusable, it also exposes potentially harmful battery components.

maintenance & service guide

Presario 1800/1800T Series

Models: XL280, XL380, XL381,
and XL390

Troubleshooting

This chapter covers troubleshooting and resolving common problems associated with Compaq Presario 1800XL Series Notebooks. The basic steps in troubleshooting include:

1. Preparing the Notebook for troubleshooting as outlined in [Preliminary Steps](#) on the following page.
2. Performing the [Power-On Self-Test \(POST\)](#) and observing any error messages displayed.

Note: If the Notebook is unable to complete POST or an error message is displayed, skip to Step 3 below to try to resolve the problem.

3. Taking the recommended steps described later in this chapter to solve the problems.

When following the recommended actions provided in [POST](#) and [Diagnostic Error Codes](#), perform the steps in the order listed above. Rerun POST after each recommended action until the problem is solved, even if no error message occurs. Once the problem is solved, do not perform any remaining recommended solutions.

Note: If the problem is intermittent, check the Notebook several times to be sure that the problem is resolved.

1.800.AT.COMPAQ

maintenance & service guide

Presario 1800/1800T Series
Models: XL280, XL380, XL381,
and XL390

Preliminary Steps

Before running [POST](#), complete the following steps:

1. If a Power-on password is established, type the password and press the **Enter** key. If you do not know the password, clear the password (see [Clearing the Power-On Password](#) later in this chapter).
2. Run [Compaq Diagnostics](#).
3. Turn off the Notebook and its external devices.
4. Disconnect any external devices you do not want to test.

Note: Do not disconnect the printer if you want to test it or use it to log error messages.

Important: If the problem only occurs when an external device is connected to the Notebook, the problem may be related to the external device or its cable. Verify this by running [POST](#) both with and without the external device connected.

5. Install loopback plugs in the serial and parallel connectors if you would like to test these ports.
6. Ensure that the hard drive is installed in the Notebook.
7. Ensure that the battery pack is installed and the Notebook is connected to an external AC power source.

When these preliminary steps are completed, run [POST](#).

maintenance & service guide

Presario 1800/1800T Series
Models: XL280, XL380, XL381,
and XL390

Clearing the Power-On Password

 **CAUTION:** Clearing the Power-on password also removes all setup attributes that are programmed in the CMOS.

If you do not know the Power-on password, clear it by performing the following steps:

1. Turn off the Notebook.
2. Disconnect the power cord.
3. [Remove the battery.](#)
4. [Remove the Palmrest cover.](#)
5. [Remove the keyboard.](#)
6. [Remove the heat sink.](#)
7. Locate the CMOS switch to the right of the CD/DVD drive on the system board.
8. Slide the black switch to the right  holding it in this position for at least 15 seconds to ensure that the password is cleared.

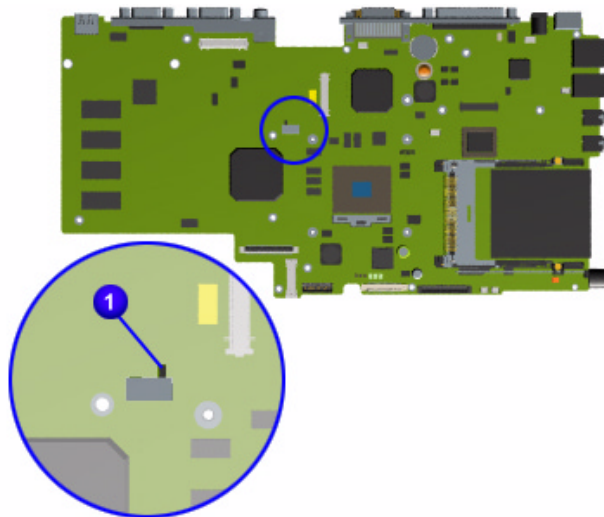

9. Reassemble the Notebook (refer to the [Removal and Replacement](#) chapter later in this MSG).
10. Turn on the Notebook to verify that the Power-on password has been cleared. If it has not been cleared, repeat this procedure.

maintenance & service guide

Presario 1800/1800T Series

Models: XL280, XL380, XL381,
and XL390

Power-On Self-Test (POST)

To run POST, complete these steps:

Turn off the Notebook, then turn it on again. As soon as the Compaq logo appears, press the **ESC** key to display the POST messages as they occur. Remember any POST error codes that are displayed.

If the Notebook does not beep, POST has successfully completed its test and detected no errors. The Notebook will automatically restart.

Note: If a bootable diskette is installed in the diskette drive, the system will boot from the diskette instead of the hard drive.

However, if POST detects errors, the Notebook will beep and/or display a text message.

Note: If the Notebook is not functioning well enough to complete POST, or the display is unable to show POST error messages, refer to the section [Solving Minor Problems](#) later in this chapter.

POST Error Messages

A list of the POST error codes and their descriptions is shown in the tables below.

102-System Board Failure

Probable Cause	Recommended Action
DMA, timers, and so on	Replace the system board.

162-System Options Not Set

Probable Cause	Recommended Action
Incorrect configuration	Run Setup.
CMOS reflects an invalid configuration setting.	Run Setup.
RAM failure	1. Replace the memory modules. 2. Replace the system board.
Memory test data error	1. Replace the memory modules. 2. Replace the system board.

maintenance & service guide

Presario 1800/1800T Series Models: XL280, XL380, XL381, and XL390

XX000YZZ 201–Memory Error

Probable Cause	Recommended Action
Memory failure	<ol style="list-style-type: none">1. Replace the memory modules.2. Replace the system board.

301–Keyboard Error

Probable Cause	Recommended Action
Keyboard failure	<ol style="list-style-type: none">1. Make sure the keys are not depressed during POST.2. With the Notebook in Full-Off mode, reconnect the keyboard.3. Replace the keyboard.

304–Keyboard or System Unit Error

Probable Cause	Recommended Action
Keyboard or system board error	<ol style="list-style-type: none">1. Replace the keyboard.2. Replace the TouchPad.3. Replace the system board.

601–Diskette Controller Error

Probable Cause	Recommended Action
Mismatch in drive type or failure in the diskette controller	<ol style="list-style-type: none">1. Run Checkup (TEST).2. Check or replace cables.3. Replace the system board.

605–Diskette Drive Error

Probable Cause	Recommended Action
Mismatch in drive type	<ol style="list-style-type: none">1. Run Setup.2. Check or replace cables.3. Replace the diskette drive.4. Replace the system board.

maintenance & service guide

Presario 1800/1800T Series
Models: XL280, XL380, XL381,
and XL390

1780–Primary Hard Drive 0 Failure

Probable Cause	Recommended Action
Disk 0 failed to respond	1. Run Checkup (TEST) . 2. Replace the hard drive .
Hard drive format error	1. Run Checkup (TEST) . 2. Replace the hard drive .

1782–Hard Drive Controller

Probable Cause	Recommended Action
Hard drive controller failure	1. Run Setup. 2. Replace the hard drive .

Compaq Diagnostics

Compaq Diagnostics utilities come pre-installed on 1800XL Series Notebooks. Run the diagnostic utilities to view or test system information and external devices. If you run Compaq Diagnostics from a diskette, be sure that the diagnostic program is version 10.11 or later.

The Diagnostics menu includes the following utilities:

- [Checkup \(TEST\)](#)
- [View System Information \(INSPECT\)](#)
- Prepare Notebook for a Compaq Service Call (RemotePaq)

Customers are encouraged to run the Diagnostics utilities to try to solve a problem before calling for support. [Checkup \(TEST\)](#) should be run with the options for saving the device list to a file and printing or saving the error log. The [View System Information \(INSPECT\)](#) utility should also be run with the option for printing or saving the information. Customers should have these files or the printed information available when calling for support.

Presario 1800/1800T Series
Models: XL280, XL380, XL381,
and XL390

Checkup (TEST)

TEST is included on the *Compaq Diagnostics Diskette*. TEST determines if the various Notebook components and devices are recognized by the system and are functioning properly. You can display, print, or save the information generated by TEST.

Follow these steps to run TEST:

1. Plug the Notebook into an external power source. (A low-battery condition could interrupt the program.)
2. Turn on the external devices you want to test. Connect the printer if you want to print a log of error messages.
3. Insert the *Compaq Diagnostics Diskette* in the diskette drive.
4. Turn on or restart the Notebook. The Notebook boots from the diskette, and after a few seconds, the diagnostics Welcome screen is displayed.
5. Press **Enter** to continue. The Diagnostics menu is displayed.
6. Select **Computer Checkup** from the Diagnostics menu. The Test Option menu is displayed.
7. Select **View the Device List** from the Test Option menu. A list of installed Compaq devices is displayed.
8. If the list of installed devices is correct, select **OK**. The Test Option menu is displayed.

Note: If the list is incorrect, ensure that any new devices are installed properly and run Checkup again.

9. Select one of the following from the **Test Option** menu:
 - **Quick Check Diagnostics.** Runs a quick, general test on each device with minimal prompts. If errors occur, they are displayed when the testing is complete. You cannot print or save the error messages.
 - **Automatic Diagnostics.** Runs unattended, maximum testing of each device with minimal prompts. You can choose how many times to run the tests, stop on errors, or print or save a log of errors.
 - **Prompted Diagnostics.** You can choose attended or unattended testing. Allows the most control over testing options. You can choose to stop on errors, or choose to print or save a log of errors.

Continued on the next page.

maintenance & service guide

Presario 1800/1800T Series

Models: XL280, XL380, XL381,
and XL390

10. Follow the on-screen instructions as the devices are tested. When testing is complete, the Test Option menu is displayed.
11. Exit the Test Option and Diagnostics menus.

View System Information (INSPECT)

The INSPECT utility provides information about the Notebook and installed or connected devices. You can display, print, or save the information.

Follow these steps to run INSPECT from the *Compaq Diagnostics Diskette*:

1. Turn on the external device(s) you want to test. Connect the printer if you want to print the information.
2. Insert the *Compaq Diagnostics Diskette* in the diskette drive.
3. Turn on or restart the Notebook. The Notebook boots from the diskette, and after a few seconds, the diagnostics Welcome screen is displayed.
4. Press **Enter** to continue. The Diagnostics menu is displayed.
5. Select **View System Information (INSPECT)** from the Diagnostics menu. The following list is displayed:

System	Memory
ROM	Audio
Keyboard	Operating system
System ports	System files
System storage	Windows files
Graphics	

6. Select the item you want to view and follow the on-screen instructions to cycle through the screens, return to the list and choose another item, or print the information.

maintenance & service guide

Presario 1800/1800T Series
Models: XL280, XL380, XL381,
and XL390

Diagnostic Error Codes

Diagnostic error codes are displayed if the system recognizes a problem while running the [Compaq Diagnostics](#) program. These error codes help identify subassemblies that may be damaged or defective.

The following tables list error codes, a description of the error condition, and the action required to resolve the error condition.

Important: Retest the system after completing each step. If the problem has been resolved, do not complete any remaining steps.

Note: Some of the solutions provided in this chapter involve replacing Notebook components. Refer to the specific [Removal and Replacement](#) procedures later in this guide for each component.

Select error codes by number or type:

- 101 - 114: Processor Test ([pg 10](#))
- 200 - 215: Memory Test ([pg 10](#))
- 300 - 304: Keyboard Test ([pg 11](#))
- 401 - 403: Parallel/Printer Test ([pg 11](#))
- 501 - 516: Video Test ([pg 14](#))
- 600 - 699: Diskette Drive Test ([pg 12](#))
- 1101: Serial Test ([pg 12](#))
- 1701 - 1736: Hard Drive Test ([pg 13](#))
- 2402 - 2418: Video Test ([pg 15](#))
- 2419 - 2480: Video Test ([pg 16](#))
- 3206: Audio Test ([pg 16](#))
- 3301 - 6623: DVD or CD Test ([pg 17](#))
- 8601 - 8602: TouchPad Test ([pg 17](#))

maintenance & service guide

Presario 1800/1800T Series Models: XL280, XL380, XL381, and XL390

Processor Test Error Codes		
Error Code	Description	Recommended Action
101-xx	CPU test failed	Replace the processor and retest.
102-xx	Coprocessor or Weitek Error	1. Run the Configuration and Diagnostics utilities. 2. Replace the processor and retest.
103-xx	DMA page registers test failed	The following solution applies to error codes 103-xx through 113-xx: Replace the system board and retest.
104-xx	Interrupt controller master test failed	
105-xx	Port 61 error	
106-xx	Keyboard controller self-test failed	
107-xx	CMOS RAM test failed	
108-xx	CMOS interrupt test failed	
109-xx	CMOS clock test failed	
110-xx	Programmable timer load data test failed	
113-xx	Protected mode test failed	
114-01	Speaker test failed	

Memory Test Error Codes		
Error Code	Description	Recommended Action
200-xx	Memory machine ID test failed	1. Flash the system ROM and retest. 2. Replace the system board and retest.
202-xx	Memory system ROM checksum failed	
203-xx	Write/Read test failed	The following steps apply to error codes 203-xx through 215-xx: 1. Remove the memory module and retest. 2. Install a new memory module and retest.
204-xx	Address test failed	
211-xx	Random pattern test failed	
214-xx	Noise test failed	
215-xx	Random address test failed	

maintenance & service guide

Presario 1800/1800T Series

Models: XL280, XL380, XL381,
and XL390

Keyboard Test Error Codes

Error Code	Description	Recommended Action
300-xx	Failed ID Test	The following steps apply to error codes 300-xx through 304-xx: 1. Check the keyboard connection. If disconnected, turn off the Notebook and reconnect the keyboard. 2. Replace the keyboard and retest. 3. Replace the system board and retest.
301-xx	Failed Self-Test/Interface Test	
302-xx	Failed Individual Key Test	
304-xx	Failed Keyboard Repeat Test	

Parallel/Printer Test Error Codes

Error Code	Description	Recommended Action
401-xx	Printer failed or not connected	The following steps apply to error codes 401-xx through 403-xx: 1. Connect the printer. 2. Check power to the printer. 3. Install loopback connector on printer port and retest. 4. Check port and IRQ configuration. 5. Replace the system board and retest.
402-xx	Failed Port Test	
403-xx	Printer pattern test failed	

maintenance & service guide

Presario 1800/1800T Series
Models: XL280, XL380, XL381,
and XL390

Diskette Drive Test Error Codes

Error Code	Description	Recommended Action
600-xx	Diskette ID drive types test failed	The following steps apply to error codes 600-xx through 698-xx: 1. Replace the diskette media and retest. 2. Check and/or replace the diskette drive cables and retest. 3. Replace the diskette drive and retest. 4. Replace the system board and retest.
601-xx	Diskette format failed	
602-xx	Diskette read test failed	
603-xx	Diskette write, read, compare test failed	
604-xx	Diskette random read test failed	
605-xx	Diskette ID media failed	
606-xx	Diskette speed test failed	
609-xx	Diskette reset controller test failed	
610-xx	Diskette change line test	
697-xx	Diskette type error	
698-xx	Diskette drive speed not within limits	
699-xx	Diskette drive/media ID error	1. Replace media. 2. Run the Configuration and Diagnostics utilities.

Serial Test Error Codes

Error Code	Description	Recommended Action
1101-xx	Serial port test failed	1. Check port configuration. 2. Replace the system board and retest.

maintenance & service guide

Presario 1800/1800T Series Models: XL280, XL380, XL381, and XL390

Hard Drive Test Error Codes		
Error Code	Description	Recommended Action
1701-xx	Hard drive format test failed	The following steps apply to error codes 1701-xx through 1736-xx: 1. Run the Configuration and Diagnostics utilities and verify drive type. 2. Verify that all secondary drives have secondary drive capability. 3. Replace the hard drive and retest. 4. Replace the system board and retest.
1702-xx	Hard drive read test failed	
1703-xx	Hard drive write/read/compare test failed	
1704-xx	Hard drive random seek test failed	
1705-xx	Hard drive controller test failed	
1706-xx	Hard drive ready test failed	
1707-xx	Hard drive recalibration test failed	
1708-xx	Hard drive format bad track test failed	
1709-xx	Hard drive reset controller test failed	
1710-xx	Hard drive park head test failed	
1715-xx	Hard drive head select test failed	
1716-xx	Hard drive conditional format test failed	
1717-xx	Hard drive ECC* test failed	
1719-xx	Hard drive power mode test failed	
1724-xx	Network preparation test failed	
1736-xx	Drive monitoring test failed	

*ECC = Error Correction Code

maintenance & service guide

Presario 1800/1800T Series

Models: XL280, XL380, XL381,
and XL390

Video Test Error Codes		
Error Code	Description	Recommended Action
501-xx	Video controller test failed	The following steps apply to error codes 501-xx through 516-xx: 1. Disconnect external monitor and test with the Notebook display. 2. Replace the display assembly and retest. 3. Replace the system board and retest.
502-xx	Video memory test failed	
503-xx	Video attribute test failed	
504-xx	Video character set test failed	
505-xx	Video 80 x 25 mode 9 x 14 character cell test failed	
506-xx	Video 80 x 25 mode 8 x 8 character cell test failed	
507-xx	Video 40 x 25 mode test failed	
508-xx	Video 320 x 200 mode color set 0 test failed	
509-xx	Video 320 x 200 mode color set 1 test failed	
510-xx	Video 640 x 200 mode test failed	
511-xx	Video screen memory page test failed	
512-xx	Video gray scale test failed	
514-xx	Video white screen test failed	
516-xx	Video noise pattern test failed	

maintenance & service guide

Presario 1800/1800T Series
Models: XL280, XL380, XL381,
and XL390

Video Test Error Codes		
Error Code	Description	Recommended Action
2402-xx	Video memory test failed	The following steps apply to error codes 2402-xx through 2418-xx: 1. Run the Configuration and Diagnostics utilities. 2. Replace the display assembly and retest. 3. Replace the system board and retest.
2403-xx	Video attribute test failed	
2404-xx	Video character set test failed	
2405-xx	Video 80 x 25 mode 9 x 14 character cell test failed	
2406-xx	Video 80 x 25 mode 8 x 8 character cell test failed	
2408-xx	Video 320 x 200 mode color set 0 test failed	
2409-xx	Video 320 x 200 mode color set 1 test failed	
2410-xx	Video 640 x 200 mode test failed	
2411-xx	Video screen memory page test failed	
2412-xx	Video gray scale test failed	
2414-xx	Video white screen test failed	
2416-xx	Video noise pattern test failed	
2418-xx	ECG/VGC memory test failed	

maintenance & service guide

Presario 1800/1800T Series Models: XL280, XL380, XL381, and XL390

Video Test Error Codes		
Error Code	Description	Recommended Action
2419-xx	ECG/VGC ROM checksum test failed	<p>The following steps apply to error codes 2419-xx through 2456-xx:</p> <ol style="list-style-type: none"> 1. Run the Configuration and Diagnostics utilities. 2. Disconnect external monitor and test with the Notebook display. 3. Replace the display assembly and retest. 4. Replace the system board and retest. <p>The following solution applies to error codes 2458-xx through 2480-xx: Replace the system board and retest.</p>
2421-xx	ECG/VGC 640 x 200 graphics mode test failed	
2422-xx	ECG/VGC 640 x 350 16-color set test failed	
2423-xx	ECG/VGC 640 x 350 64-color set test failed	
2424-xx	ECG/VGC monochrome text mode test failed	
2425-xx	ECG/VGC monochrome graphics mode test failed	
2431-xx	640 x 480 graphics test failure	
2432-xx	320 x 200 graphics (256-color mode) test failure	
2448-xx	Advanced VGA Controller test failed	
2451-xx	132-column Advanced VGA test failed	
2456-xx	Advanced VGA 256 Color test failed	
2458-xx	Advanced VGA BitBLT test failed	
2468-xx	Advanced VGA DAC test failed	
2477-xx	Advanced VGA data path test failed	
2478-xx	Advanced VGA BitBLT test failed	
2480-xx	Advanced VGA LineDraw test failed	

Audio Test Error Codes		
Error Code	Description	Recommended Action
3206-xx	Audio System Internal Error	Replace the system board and retest.

maintenance & service guide

Presario 1800/1800T Series

Models: XL280, XL380, XL381,
and XL390

TouchPad Interface Test Error Codes

Error Code	Description	Recommended Action
8601-xx	Mouse test failed	The following steps apply to error codes 8601-xx through 8602-xx: 1. Replace the TouchPad and retest. 2. Replace the system board and retest.
8602-xx	Interface test failed	

DVD or CD Drive Test Error Codes

Error Code	Description	Recommended Action
3301-xx	DVD or CD drive read test failed	The following steps apply to error codes 3301-xx through 6623-xx: 1. Replace the DVD or CD media and retest. 2. Verify that the speakers cables are properly connected. 3. Verify that drivers are loaded and properly installed. 4. Replace the CD/DVD drive and retest. 5. Replace the system board and retest.
3305-xx	DVD or CD drive seek test failed	
6600-xx	ID test failed	
6605-xx	Read test failed	
6608-xx	Controller test failed	
6623-xx	Random read test failed	

maintenance & service guide

Presario 1800/1800T Series
Models: XL280, XL380, XL381,
and XL390

Troubleshooting without Diagnostics

This section provides information about how to identify and correct some common hardware, memory, and software problems. It also explains several types of common messages that may be displayed on the screen.

 **CAUTION:** Carefully match the symptoms against the problem described to avoid a misdiagnosis.

 **WARNING:** To avoid a potential shock hazard during troubleshooting procedures, disconnect all power sources before removing the keyboard cover or the display bezel.

Select from the following to diagnose and solve problems related to each topic:

[Audio](#)

[Battery](#)

[CD or DVD Drive](#)

[Diskette Drive](#)

[Display](#)

[Hard Drive](#)

[Hardware Installation](#)

[Keyboard/Numeric Keypad](#)

[Memory](#)

[PC Card](#)

[Power](#)

[Printer](#)

[TouchPad](#)

Before Replacing Parts

- Verify that all cables are properly connected to the parts that are to be tested.
- Run Setup after connecting external devices.
- Verify that all required device drivers are installed.
- Verify that all required changes have been made to the CONFIG.SYS file.
- Verify that all required changes have been made to the AUTOEXEC.BAT file.
- Verify that all printer drivers have been installed for each application.
- Check the printer connection.

maintenance & service guide

Presario 1800/1800T Series
Models: XL280, XL380, XL381,
and XL390

Solving Minor Problems

Some problems and possible solutions are outlined in the following tables. If the problem appears to be related to a software application, check the documentation provided with the software.

Audio Solutions

A common audio problem and solution are listed in the following table.

Audio		
Problem	Probable Cause	Solution
Notebook does not beep after the Power-On Self-Test (POST).	This is typical; it indicates successful completion of the Power-On Self-Test (POST).	No action is required.



Battery Pack/Gauge Solutions

Some causes and solutions for common battery pack problems are listed in the following table. [Power Solutions](#) later in this chapter may also be applicable to the following problems.

Battery Pack/Gauge		
Problem	Probable Cause	Solution(s)
Notebook won't turn on when battery pack is inserted and power cord is unplugged.	Battery pack is discharged.	<ul style="list-style-type: none"> • Connect the Notebook to an external power source and charge the battery pack.
		<p>OR</p> <ul style="list-style-type: none"> • Replace the battery pack with a fully charged battery pack.
		Check the battery connectors on the system board to verify that they are evenly spaced and not bent or broken.

maintenance & service guide

Presario 1800/1800T Series Models: XL280, XL380, XL381, and XL390

Battery Pack/Gauge		
Problem	Probable Cause	Solution(s)
<p>Notebook is beeping and battery () icon is blinking.</p>	Battery charge is low.	<p>Immediately save any open file(s). Then complete one of the following steps:</p> <ul style="list-style-type: none"> • Connect the Notebook to an external power source to charge the battery pack. • Turn off the Notebook or initiate Hibernation until you can find another power source or charge the battery pack.
<p>Battery () icon on the front of the unit blinks to indicate low-battery condition, but Notebook does not beep.</p>	Volume is turned down too low.	Adjust the volume.
<p>Battery charging  icon doesn't light and battery pack won't fast charge.</p>	Battery pack is already charged.	No action is necessary.
	Battery pack was exposed to temperature extremes.	Allow time for the battery pack to return to room temperature.
	Battery pack is at the end of its life.	Replace the battery pack.
<p>You have to set the date and time every time you turn on the Notebook.</p>	RTC battery is dead.	Replace the RTC battery.
<p>Battery charge does not last as long as expected.</p>	Battery is exposed to high or extremely cold temperatures.	<p>Keep the battery pack within the recommended temperature range for operation or storage.</p> <ul style="list-style-type: none"> • Operating Range: 50°F to 104°F (10°C to 40°C) • Storage Range: -4°F to 86°F (-20°C to 30°C) <p>Recharge the battery pack.</p>

maintenance & service guide

Presario 1800/1800T Series Models: XL280, XL380, XL381, and XL390

Battery Pack/Gauge		
Problem	Probable Cause	Solution(s)
	Battery has partially self-discharged.	Recharge the battery. Discharge the battery completely and then recharge it.
Battery charge does not last as long as expected.	Power management is disabled.	Set a power management level in Setup.
	An external device or PC Card is draining the battery.	Turn off or disconnect external devices when not in use.
Battery pack is warm to the touch after charging.	Normal warming has occurred due to charging.	No action is required.
Battery pack operating time is far less than the documented average operating time.	Power management is turned off or disabled.	Enable power management in Setup and in Windows Power Properties.
	An external device or PC Card is draining the battery.	Turn off or disconnect external devices when not in use.
	Battery pack has partially self-discharged.	Condition the battery pack by fully charging, fully discharging, then fully recharging it. To maintain the charge, leave battery packs in the Notebook when it is connected to external power. If the Notebook is disconnected from external power for more than two weeks, remove battery packs from the Notebook to reduce the discharge rate.
	Battery pack is exposed to high or extremely cold temperatures.	Keep the battery pack within the recommended temperature range for operation or storage. <ul style="list-style-type: none"> • Operating Range: 50°F to 104°F (10°C to 40°C) • Storage Range: -4°F to 86°F (-20°C to 30°C) Recharge the battery pack.

maintenance & service guide

Presario 1800/1800T Series Models: XL280, XL380, XL381, and XL390

CD and DVD Drive Solutions

Some causes and solutions for CD and DVD drive problems are listed in the following table.

CD or DVD Drive		
Problem	Probable Cause	Solution(s)
CD or DVD drive cannot read a Compact Disc or Digital Versatile Disc.	Disc is upside down or is improperly inserted in the CD or DVD drive.	Open the loading tray, lay the compact disc in it (label side up), then close the tray.
	CD is CD Plus or Pregap/Track 0 type.	Cannot read these type CDs in 24X. Remove the CD.

Diskette Drive Solutions

Some causes and solutions for diskette drive problems are listed in the following table.

Diskette Drive		
Problem	Probable Cause	Solution(s)
Diskette drive cannot write to a diskette.	Diskette is write-protected.	Disable the diskette's write-protect feature or use a diskette that is not write-protected.
	Notebook is writing to the wrong drive.	Check the drive letter in the path statement.
	Not enough space is left on the diskette.	Use another diskette.
	Drive error has occurred.	Run TEST from the Compaq Diagnostics diskette.
Diskette drive cannot read a diskette.	Diskette is not formatted.	Format the diskette. At the system prompt, enter FORMAT A:
	The wrong type of diskette is being used.	Use the type of diskette required by the drive.
	Diskette has a bad sector.	Copy files to hard drive or another diskette. Reformat bad diskette.
	Drive error has occurred.	Run TEST from the Compaq Diagnostics diskette.

maintenance & service guide

Presario 1800/1800T Series Models: XL280, XL380, XL381, and XL390

Diskette Drive		
Problem	Probable Cause	Solution(s)
Diskette drive cannot read a diskette.	Diskette is not formatted.	Format the diskette. At the system prompt, enter FORMAT A:
Cannot boot from diskette.	Bootable diskette is not in the diskette drive.	Put the bootable diskette in the diskette drive.
	Diskette Boot has incorrect setting in Setup.	Run Setup and set diskette as first to boot.

Display Solutions

This section lists some causes and solutions for common Notebook display and external monitor problems.

You can perform a monitor self-test on an external VGA color or monochrome monitor by completing the following steps:

1. Turn off the monitor.
2. Turn off the Notebook.
3. Disconnect the monitor signal cable from the Notebook.
4. Turn on the monitor and allow it to warm up for one minute.

The display should be white. A narrow black border may also appear on the left and right sides of the display. Either of these displays indicates that the monitor is working properly.

Display		
Problem	Probable Cause	Solution(s)
Screen is dim.	Brightness control (if applicable) is not set properly.	Adjust the display brightness by using Fn+F7 or Fn+F8 .
	The Notebook display is in direct sunlight.	Tilt the display or move the Notebook.
Screen is blank.	Screen saver was initiated or display was turned off by Power Management due to lack of user activity.	Press any key or touch the TouchPad.

maintenance & service guide

Presario 1800/1800T Series
Models: XL280, XL380, XL381,
and XL390

Display		
Problem	Probable Cause	Solution(s)
	Display has overheated.	Turn off the Notebook, and if necessary move it out of direct sunlight to allow it to cool.
Display is blank and the Standby icon is flashing.	System is in Standby mode.	Press any key or touch the TouchPad.
Notebook display is blank and the screen on an external monitor displays information.	Display function was switched to the external monitor.	Press Fn+F3 to switch between the external monitor and the Notebook display (you may have to press more than once).
Notebook display flashes or has garbled characters when Notebook is connected to external monitor.	The external monitor is set for 1024 x 768 or higher resolution and view is toggled back to the Notebook display, which supports up to 800 x 600.	Restart the Notebook.
The light tubes on the edge of the display panel do not light up at all and the Power-On Self-Test (POST) completes on startup.**	Improper backlight or display cable connections.	<ol style="list-style-type: none"> 1. Check the display cable connections and retest. 2. Replace the display assembly.
	Defective inverter board.	Replace the display assembly.
	Defective display cable.	Replace the display assembly.
	Defective display panel.	Replace the display assembly.
	Defective system board.	Replace the system board.
The light tubes on the edge of the display panel do not light up at all and the Power-On Self-Test does not complete on startup.**	Defective system board.	Replace the system board.

***The backlight or its power circuitry has failed. If the backlight is not functioning, the POST result cannot be observed. Connect the unit to an external monitor before restarting the unit. If an external monitor is not available verify that POST is complete by opening and closing the display, listening for the single or double beep, and watching for the icons to turn on at the front of the Notebook.*

maintenance & service guide

Presario 1800/1800T Series Models: XL280, XL380, XL381, and XL390

Display		
Problem	Probable Cause	Solution(s)
Backlight (brightness) cannot be adjusted with Fn+F7 or Fn+F8.	Improper display cable connections.	1. Reseat the display cable to the system board. 2. Replace the display assembly.
	Defective inverter board.	Replace the display assembly.
	Defective display cable.	Replace the display assembly.
This display panel has a continuous pattern across it (e.g., "jailbars" pattern), has a single color on it, or has garbled graphics across the entire panel. This failure is for patterns across the entire panel (not just on one section).	Defective system board.	Replace the system board.
	Improper display cable connections.	Reseat the display cable to the following until the problem is solved: 1. System board 2. Display assembly
	Defective display cable.	Replace the display assembly.
A single line, small group of lines, or block appears on the display panel. This failure occurs in only a section of the display panel.	Defective inverter board.	Replace the display assembly.
	Defective system board.	Replace the system board.
	Defective display panel.	Replace the display assembly.

Note: When you perform a "self-test" on an external VGA color or monochrome monitor, the screen should be white. A narrow black border may also appear on the left and right sides of the display. Either of these displays indicates that the monitor is working properly.

maintenance & service guide

Presario 1800/1800T Series Models: XL280, XL380, XL381, and XL390

Hard Drive Solutions

Some causes and solutions for hard drive problems are listed in the following table.

 **CAUTION:** To prevent loss of information, maintain an up-to-date backup of your hard drive in case of errors or failures.

Hard Drive		
Problem	Probable Cause	Solution(s)
Reading hard drive takes an unusually long time after restarting the Notebook.	System entered Hibernation due to low-battery condition and is now exiting from it.	Give the system time to restore the previously saved data to its exact state before Hibernation.
Hard drive error occurs.	Hard drive has bad sectors or has failed.	Run Checkup (TEST) .
Hard drive does not work.	Hard drive is not seated properly.	Turn off and unplug the Notebook, remove the battery pack , and remove and then reinstall the hard drive .

Hardware Installation Solutions

The possible cause and some solutions for a hardware installation problem are listed in the following table.

Hardware Installation		
Problem	Probable Cause	Solution(s)
A new device is not recognized as part of the system.	Cable(s) of new external device are loose or power cables are unplugged.	Ensure that all cables are properly and securely connected.
	Power switch of new external device is not turned on.	Turn off the Notebook, turn on the external device, then turn on the Notebook to integrate the device with the system.
	Device is not seated properly.	Turn off the Notebook and reinsert the device.

maintenance & service guide

Presario 1800/1800T Series
Models: XL280, XL380, XL381,
and XL390

Keyboard/Numeric Keypad Solutions

Some causes and solutions for keyboard/numeric keypad problems are listed in the following table.

Keyboard/Numeric Keypad		
Problem	Probable Cause	Solution(s)
Embedded numeric keypad on Notebook keyboard is disabled.	Num Lock function is not enabled.	Press the Shift+NumLk keys to enable the Num Lock function and embedded numeric keypad (Num Lock light  is on).
Embedded numeric keypad is disabled and Num Lock function is on.	External numeric keypad is connected to the Notebook.	Disconnect the external numeric keypad from the Notebook.

Memory Solutions

Some causes and solutions for memory problems are listed in the following table.

Memory		
Problem	Probable Cause	Solution(s)
Memory count during Power-On Self-Test (POST) is incorrect.	Optional memory expansion card is installed incorrectly, is incompatible with the Notebook, or is defective.	Ensure that the optional memory expansion card is installed correctly, and then restart the Notebook.
"Out of Memory" message is displayed on the screen or insufficient memory error occurs during operation.	System ran out of memory for the application.	Check the application documentation for memory requirements. If necessary, install additional memory.
	Too many TSR (terminate-and-stay-resident) applications are running.	Remove from memory any TSR applications you do not need.

maintenance & service guide

Presario 1800/1800T Series
Models: XL280, XL380, XL381,
and XL390

PC Card Solutions

The following table lists some causes and solutions for PC card problems.

PC Card		
Problem	Probable Cause	Solution(s)
While turned on, the Notebook does not beep when a PC card is inserted.	Card is not inserted properly.	Make sure that the card is inserted properly.
	PC card beeps are disabled.	From Control Panel, double-click PC Card , click the Global Settings tab, and enable PC Card sound effects .
	Speaker is turned off or volume is turned down.	Press Volume buttons to turn the speaker on and then increase the volume.
PC card modem, fax, or network card does not work.	PC card drivers are not installed.	From Control Panel, double-click Add New Hardware for installation instructions. If PC card or drivers are not compatible with Windows, install drivers and use the PC card in MS-DOS mode.
	Card or card driver is not supported.	Contact a Compaq authorized Service Provider for a list of PC cards tested successfully in Compaq platforms.
PC card modem, fax, or network card does not work.	Card is not fully inserted into the slot or is not inserted properly.	Ensure that the card is inserted in the slot in the correct orientation.
	Telephone cord is not plugged in all the way.	Check and secure telephone connection.
	Necessary drivers are not installed (enabled).	Install drivers.
PC card modem or fax card does not work.	You are trying to access the card using the wrong COM port.	See the Specifications chapter to verify the correct COM port.
	The card conflicts with a serial device.	See the Specifications chapter to verify the correct address.

maintenance & service guide

Presario 1800/1800T Series Models: XL280, XL380, XL381, and XL390

PC Card		
Problem	Probable Cause	Solution(s)
PC card modem or fax card does not work.	The card is not supported.	Use supported cards only.
Modem network PC card does not work.	Network driver is not installed or is not set up properly.	Install driver.
	Telephone cord is not properly connected.	Verify telephone connection.
Memory or storage PC card does not work.	SRAM and Flash memory cards require the memory card driver (loaded and enabled).	Install driver(s).
	Flash memory cards require the Microsoft FlashFile System.	
	Hard drives on Flash mass storage cards require the PC card ATA driver.	
	You are trying to access the hard drive card using the wrong drive letter.	Double-click My Computer to verify the drive letter assigned to the card.
	The card is not supported.	Contact a Compaq-authorized Service Provider for a list of PC cards tested successfully in Compaq platforms.

maintenance & service guide

Presario 1800/1800T Series Models: XL280, XL380, XL381, and XL390

Power Solutions

Some causes and solutions for power problems are listed in the following table. See also [Battery Pack/Gauge Solutions](#) in this chapter.

Power		
Problem	Probable Cause	Solution(s)
Notebook will not turn on and the battery pack is not inserted.	Notebook is not connected to a power source.	Insert battery or connect an external power source.
	Power cords to the external power source are unplugged.	Ensure that power cords connecting the Notebook and the external power source are plugged in properly.
Notebook turned off while it was left unattended and the Power  icon is off.	Power adapter is defective.	Replace AC Adapter and restart.
	System initiated Hibernation after a preset timeout.	Turn on the Notebook.
	System initiated Hibernation due to a critical low-battery condition.	Replace the battery pack with a fully charged battery pack, or connect the Notebook to an external power source. Then turn on the Notebook.
	System board is defective.	Replace the system board.

maintenance & service guide

Presario 1800/1800T Series Models: XL280, XL380, XL381, and XL390

Printer Solutions

If you experience problems printing, run a printer self-test. Refer to the documentation provided with the printer for instructions. If the self-test fails, the problem is associated with the printer, not the Notebook. To diagnose other printing problems, refer to the printing section of the application documentation.

Printer		
Problem	Probable Cause	Solution(s)
Printer will not turn on.	The signal cable may not be connected properly, or the printer is unplugged.	Make sure that the signal cable is properly connected and that the power cord is connected to the electrical outlet.
Printer will not print.	Printer is not turned on or is offline.	Turn the printer on and set it to online.
	Paper tray is empty.	Fill the paper tray with paper and set the printer to online.
	The device drivers for the application are not installed.	Refer to the printer documentation to install the correct printer driver.
Printer prints garbled information.	Printer is set up for a network, but is not connected to the network.	Connect the printer to the network.
	Printer cable is too long, unshielded, or defective.	Replace the cable.
	Correct printer drivers are not installed.	Refer to the printer documentation to install the correct printer driver.
	Cable is not connected properly.	Make sure that the printer signal cable is properly connected to the Notebook.
	Cable is defective.	Replace the printer cable and retest.

maintenance & service guide

Presario 1800/1800T Series Models: XL280, XL380, XL381, and XL390

TouchPad/Pointing Device Solutions

The following table lists some causes and solutions for TouchPad/pointing device problems.

TouchPad/Pointing Device		
Problem	Probable Cause	Solution(s)
TouchPad or mouse does not work.	Incorrect or no device driver is installed.	Install the device driver and add to the AUTOEXEC.BAT file or CONFIG.SYS file.
	The device driver is not installed in Windows.	Install the TouchPad/mouse driver in Windows.
External mouse does not work.	Mouse is not securely connected or is connected to an incorrect external connector.	Ensure that the mouse is securely connected to the appropriate external connector.
TouchPad or mouse does not work even though the device is enabled in Windows.	Mouse is not enabled.	Enter mouse at the system prompt to activate the mouse device driver. Add a line in the AUTOEXEC.BAT file to automatically activate the mouse driver each time the computer is turned on or restarted.
	Cable is not properly seated on TouchPad board.	Reseat cable.
	Defective TouchPad board.	Replace the TouchPad board.
	Defective system board.	Replace system board.
	Device driver is not correctly installed in Windows.	Install the appropriate device driver in Windows.
Cursor skips or moves abnormally when using the TouchPad.	The TouchPad needs to be cleaned.	Clean the TouchPad with a cloth dampened with alcohol or an ammonia-based glass cleaner. Wipe up liquid with a dry cloth.

maintenance & service guide

Presario 1800/1800T Series
Models: XL280, XL380, XL381,
and XL390

Contacting Compaq Support

Customers should provide the following information when contacting Compaq Reseller Support:

- Product name
- Product serial number
- Purchase date
- Conditions under which the problem occurred
- Any error messages that have occurred
- Hardware configuration
- Type of printer connected
- Hardware/software installed
- Printed result of [Checkup \(TEST\)](#)
- Printed copies of CONFIG.SYS and AUTOEXEC.BAT files, if possible.

Shipping Preparation

Before shipping the Notebook, complete the following steps:

1. Back up the critical hard drive files. Ensure that backup tapes/diskettes are not exposed to electrical or magnetic fields while stored or in transit.
2. Turn off the Notebook and all external devices.
3. Disconnect the external devices from their power sources, then from the Notebook.

Important: Make sure that there is no diskette in the diskette drive and that there are no PC cards in the PC slots.

4. Close the display and all exterior doors of the Notebook.
5. Pack the Notebook with sufficient packing material to protect it. Use the original packing box or similar packaging.

maintenance & service guide

Presario 1800/1800T Series Models: XL280, XL380, XL381, and XL390

Removal & Replacement

This chapter details the necessary preparations for disassembling the Notebook and explains removing and replacing each component of the Presario 1800XL Series Notebooks.

Electrostatic Discharge

 **CAUTION:** When removing or replacing parts, be careful to discharge static electricity before touching the Notebook's internal components.

A sudden discharge of static electricity from a finger or other conductor can destroy static-sensitive devices and microcircuitry. Often the spark is neither felt nor heard, but damage occurs. An electronic device exposed to an electrostatic discharge may work perfectly throughout a normal cycle. However, the discharge degrades internal layers, which reduces the operating life of the device. Networks built into many integrated circuits provide some protection, but in many cases the discharge still contains enough power to alter device parameters or melt silicon junctions.

The table below shows the amount of static electricity generated by common activities associated with servicing computers.

Generated Electrostatic Voltage			
Activity	Relative Humidity		
	10%	40%	55%
Walking across carpet	35,000 V	15,000 V	7,500 V
Walking across vinyl floor	12,000 V	5,000 V	3,000 V
Motions of bench worker	6,000 V	800 V	400 V
Removing DIPS from plastic tubes	2,000 V	700 V	400 V
Removing DIPS from vinyl trays	11,500 V	4,000 V	2,000 V
Removing DIPS from styrofoam	14,500 V	5,000 V	3,500 V
Removing bubble pack from PCBs	26,000 V	20,000 V	7,000 V
Packing PCBs in foam-lined box	21,000 V	11,000 V	5,000 V

 **CAUTION:** As little as 700 Volts can degrade Notebook components. Be sure to ground yourself before touching the Notebook or its subassemblies.

1.800.At.COMPAQ

maintenance & service guide

Presario 1800/1800T Series

Models: XL280, XL380, XL381,
and XL390

Required Tools

The following items are required to service the Notebook:

- Torx T-8 screwdriver
- 5 mm nut drivers (for screwlocks and standoffs)
- Small standard screwdriver
- Small Phillips screwdriver

Screws

The screws used in the Notebook are **not** interchangeable. If an incorrect screw is used during the reassembly process, it can damage the unit. Compaq strongly recommends that all screws removed during disassembly be kept with the part that was removed, then returned to their proper locations.

Important: As each subassembly is removed from the Notebook, place it together with its screws away from the work area to prevent damage.

Connectors & Plastic Parts

Plastic parts can be damaged by the use of excessive force during disassembly and reassembly. When handling plastic parts, use care. Apply pressure only at the points designated in the instructions.

maintenance & service guide

Presario 1800/1800T Series

Models: XL280, XL380, XL381,
and XL390

ZIF Connector

The 1800XL Notebooks use many zero insertion force (ZIF) connectors on the system board.

 **CAUTION:** A ZIF connector and its attached cable can be easily damaged. Handle only the connector slide when removing or replacing a cable. Never pull or twist on the cable while it is connected.

To remove a cable from a ZIF connector, lift both corners of the ZIF connector and slide the cable straight out with constant light pressure.

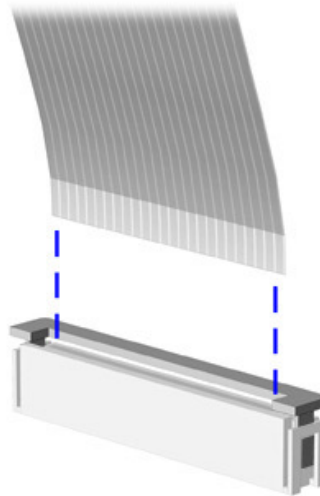

 **CAUTION:** When servicing these Notebooks, make sure that cables are placed in their proper locations during the reassembly process. Improper cable placement can damage the Notebook.

maintenance & service guide

Presario 1800/1800T Series
Models: XL280, XL380, XL381,
and XL390

Cables

Most cables used in the Notebook are ribbon cables.

Cables must be handled with extreme care to avoid damage. Use the following precautions when handling cables to avoid damage to the cable and the Notebook:

- Always handle cables by their connectors.
- In all cases, avoid bending, twisting, pulling, or tearing cables.
- Apply only the minimum pressure required to seat or unseat cables from their connectors.
- Make sure that cables are routed in such a way that they cannot be caught or snagged by parts being removed or replaced.
- Handle flex cables with extreme care; they can tear easily.

 **CAUTION:** When servicing a Notebook, make sure that cables are placed in their proper locations during the reassembly process. Improper cable placement can cause severe damage to the unit.

The following illustrations show the proper placement for each cable:

- [Hard Drive Ribbon Cable](#)
- [CD/DVD Ribbon Cable](#)
- [Diskette Drive Ribbon Cable](#)
- [Speaker Assembly Cable](#)
- [Keyboard Ribbon Cable](#)

maintenance & service guide

Presario 1800/1800T Series
Models: XL280, XL380, XL381,
and XL390

Hard Drive Ribbon Cable

The position for the hard drive ribbon cable is shown below.



CAUTION: When servicing this Notebook, make sure that cables are placed in their proper locations during the reassembly process. Improper cable placement can damage the Notebook.

The following illustrations show the proper placement for other cables in the unit:

- [CD/DVD Ribbon Cable](#)
- [Diskette Drive Ribbon Cable](#)
- [Speaker Assembly Cable](#)
- [Keyboard Ribbon Cable](#)

To remove or replace the hard drive, see [Hard Drive Removal Procedures](#) later in this chapter.

maintenance & service guide

Presario 1800/1800T Series
Models: XL280, XL380, XL381,
and XL390

CD/DVD Ribbon Cable

The position for the CD/DVD drive ribbon cable is shown below.



CAUTION: When servicing this Notebook, make sure that cables are placed in their proper locations during the reassembly process. Improper cable placement can damage the Notebook.

The following illustrations show the proper placement for other cables in the unit:

- [Hard Drive Ribbon Cable](#)
- [Diskette Drive Ribbon Cable](#)
- [Speaker Assembly Cable](#)
- [Keyboard Ribbon Cable](#)

To remove or replace the CD or DVD drive, see [CD/DVD Drive Removal Procedures](#) later in this chapter.

maintenance & service guide

Presario 1800/1800T Series
Models: XL280, XL380, XL381,
and XL390

Diskette Drive Ribbon Cable

The position for the diskette drive ribbon cable is shown below.



CAUTION: When servicing this Notebook, make sure that cables are placed in their proper locations during the reassembly process. Improper cable placement can damage the Notebook.

The following illustrations show the proper placement for other cables in the unit:

- [Hard Drive Ribbon Cable](#)
- [CD/DVD Ribbon Cable](#)
- [Speaker Assembly Cable](#)
- [Keyboard Ribbon Cable](#)

To remove or replace the diskette drive, see [Diskette Drive Removal Procedures](#) later in this chapter.

maintenance & service guide

Presario 1800/1800T Series
Models: XL280, XL380, XL381,
and XL390

Speaker Assembly Cable

The position for the speaker assembly cable is shown below. The cable is routed under the battery charger board and under the edge of the system board.



CAUTION: When servicing the Notebook, make sure that cables are placed in their proper locations during the reassembly process. Improper cable placement can damage the Notebook.

The following illustrations show the proper placement for other cables in the unit:

- [Hard Drive Ribbon Cable](#)
- [Diskette Drive Ribbon Cable](#)
- [CD/DVD Ribbon Cable](#)
- [Keyboard Ribbon Cable](#)

To remove or replace the speaker assembly, see [Speaker Assembly Removal Procedures](#) later in this chapter.

maintenance & service guide

Presario 1800/1800T Series
Models: XL280, XL380, XL381,
and XL390

Keyboard Ribbon Cable

The position for the keyboard ribbon cable is shown below.



CAUTION: When servicing the Notebook, make sure that cables are placed in their proper locations during the reassembly process. Improper cable placement can damage the Notebook.

The following illustrations show the proper placement for other cables in the unit:

- [Hard Drive Ribbon Cable](#)
- [Diskette Drive Ribbon Cable](#)
- [CD/DVD Ribbon Cable](#)
- [Speaker Assembly Cable](#)

To remove or replace the keyboard, see [Keyboard Removal Procedures](#) later in this chapter.

maintenance & service guide

Presario 1800/1800T Series
Models: XL280, XL380, XL381,
and XL390

Preparing the Notebook for Disassembly

Before beginning the removal or replacement of any Notebook components, complete the following steps:

1. Disconnect AC power source and any external devices.
2. Disconnect the Notebook from the QuikDock ([pg 11](#)).
3. Remove any PC cards.
4. Remove the battery pack ([pg 12](#)).

Important: The battery pack should be removed before performing any internal maintenance on the Notebook.

 **CAUTION:** Metal objects can damage the battery pack as well as the battery contacts in the battery compartment. To prevent damage, do not allow metal objects to touch the battery contacts. Place only the battery pack for the Compaq Presario 1800 Series Notebooks in the battery compartment. Do not force the battery pack into the bay if insertion is difficult.

 **CAUTION:** Do not crush, puncture, or incinerate the battery pack. Do not open a battery pack; this damages the pack, makes it unusable, and exposes potentially harmful battery components. No field-serviceable parts are located inside the battery pack.

Note: The Compaq Presario 1800 Series Notebooks have several screws of various sizes that are **not** interchangeable. Care must be taken during reassembly to ensure that the correct screws are used in their correct locations. During removal, keep screws with their associated subassembly.

Important: As each component is removed from the Notebook, place the it together with its screws away from the work area to prevent damage.

maintenance & service guide

Presario 1800/1800T Series
Models: XL280, XL380, XL381,
and XL390

Removal Procedures

This section outlines the removal and replacement of each component of the 1800XL Series Notebooks. To prepare the Notebook for disassembly, refer to the previous sections of this chapter.

QuikDock

To disconnect from the QuikDock, lift the handle on top of the QuikDock to release the Notebook and lift the Notebook straight up.

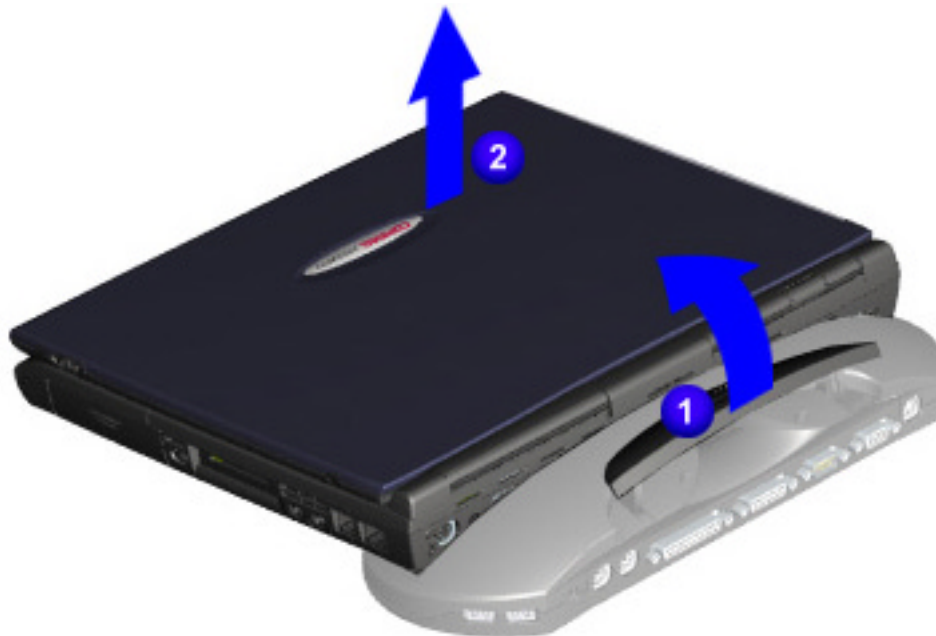

maintenance & service guide

Presario 1800/1800T Series
Models: XL280, XL380, XL381,
and XL390

Battery Pack

To remove the battery pack, complete the following steps:

1. Slide the battery pack compartment door down and remove it from the chassis ❶.
2. Pull the battery pack from the chassis by the tab located on the end of the battery pack ❷.

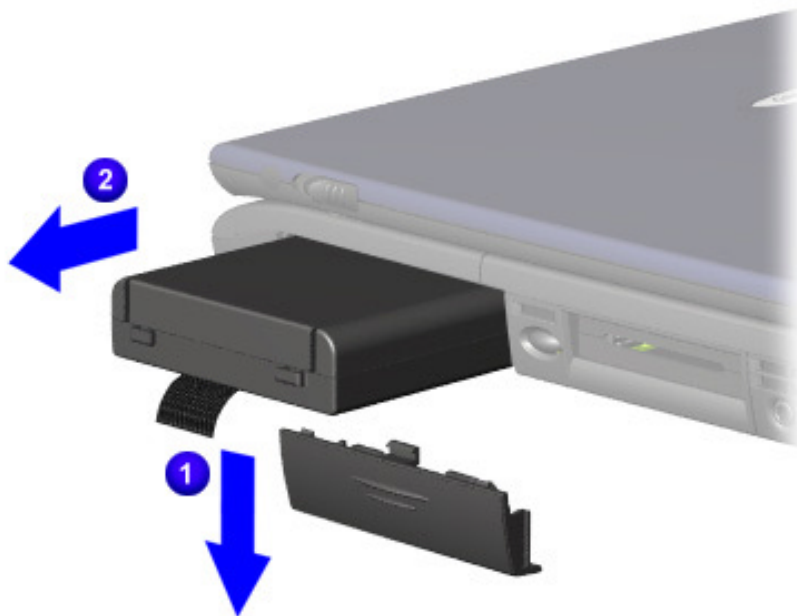

To replace the battery pack, reverse these procedures.

Important: The battery pack should be removed before performing any internal maintenance on the Notebook.

⚠ **CAUTION:** Metal objects can damage the battery pack as well as the battery contacts in the battery compartment. To prevent damage, do not allow metal objects to touch the battery contacts. Place only the battery pack for the Compaq Presario 1800 Series Portable Notebooks into the battery compartment. Do not force the battery pack into the bay if insertion does not occur easily.

⚠ **CAUTION:** Do not crush, puncture, or incinerate the battery pack. Do not open a battery pack; this damages the pack, makes it unusable, and exposes potentially harmful battery components. No field-serviceable parts are located inside the battery pack.

maintenance & service guide

Presario 1800/1800T Series

Models: XL280, XL380, XL381,
and XL390

Palmrest Cover with TouchPad

Note: It is not necessary to remove the display panel assembly to access the interior components of the Notebook.

To remove the Palmrest cover with TouchPad, complete the following steps:

1. Prepare the Notebook for disassembly ([pg 10](#)).
2. Close the display and turn the Notebook upside down.
3. Remove four screws from the bottom of the Notebook, and one from the battery compartment.

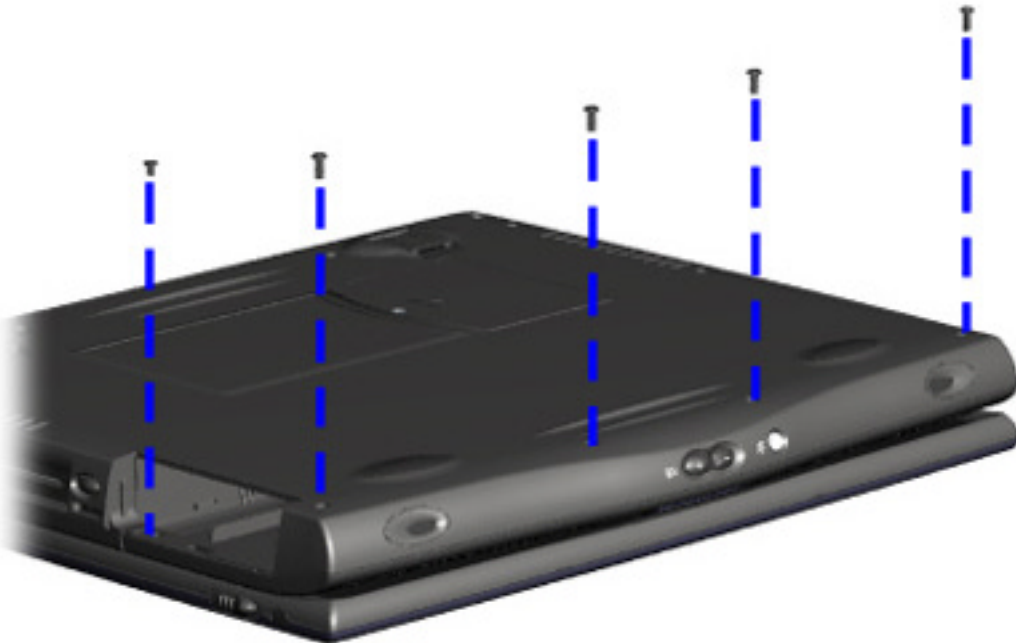

Continued on the next page.

maintenance & service guide

Presario 1800/1800T Series
Models: XL280, XL380, XL381,
and XL390

4. Turn the Notebook right side up and open the display.
5. Lift up the front end of the Palmrest cover.

Note: It may be necessary to apply pressure on the sides of the Palmrest cover to release it from the chassis.

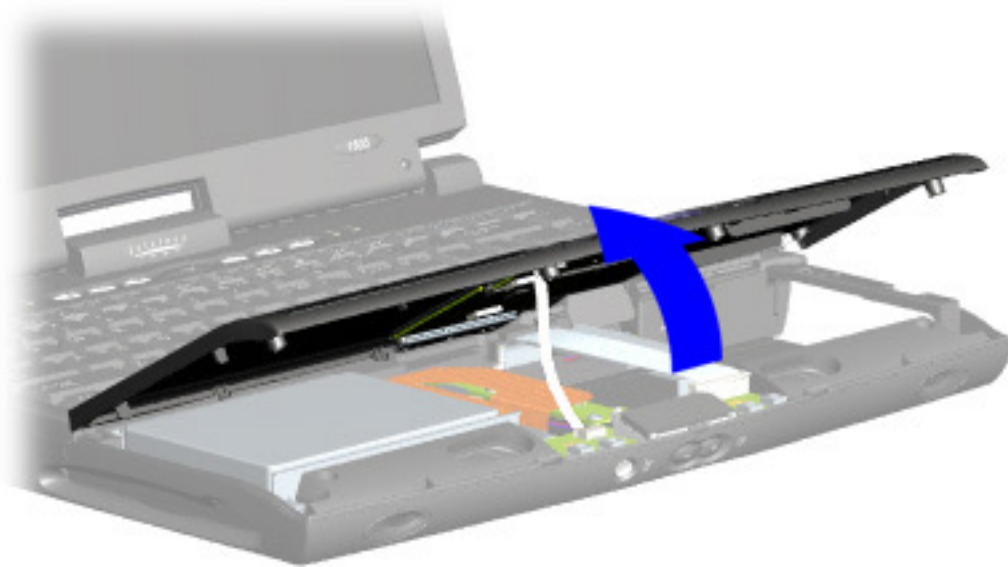

Continued on the next page.

maintenance & service guide

Presario 1800/1800T Series
Models: XL280, XL380, XL381,
and XL390

6. Disconnect the flex cable from the [ZIF Connector](#) on the DisqPlay module.

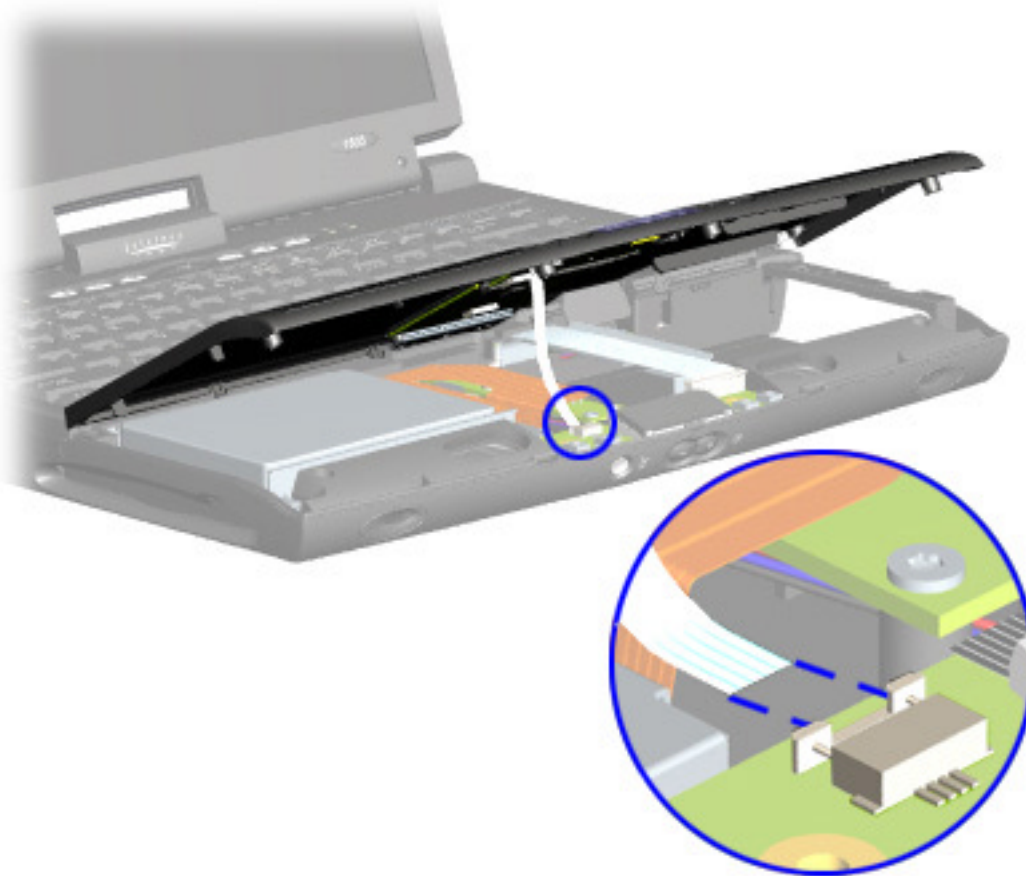

To replace the Palmrest cover with TouchPad, reverse these procedures.

maintenance & service guide

Presario 1800/1800T Series
Models: XL280, XL380, XL381,
and XL390

Keyboard

To remove the keyboard, complete the following steps:

1. Prepare the Notebook for disassembly ([pg 10](#)).
2. Remove the Palmrest cover ([pg 13](#)).
3. Gently lift the front of the keyboard, disconnect the flex cable from the [ZIF Connector](#) on the system board, and remove the keyboard.

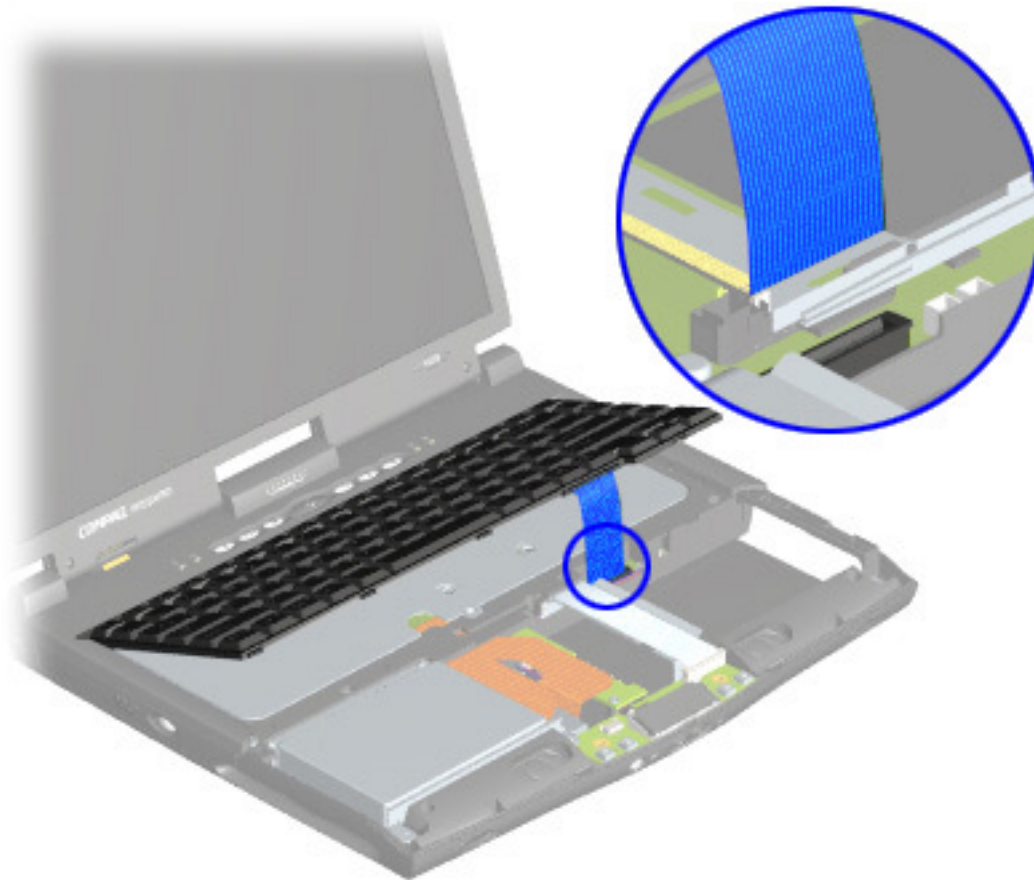

To replace the keyboard, reverse these procedures.

Note: When replacing the keyboard, the [Keyboard Ribbon Cable](#) should fold behind the [ZIF Connector](#) and not underneath the keyboard.

maintenance & service guide

Presario 1800/1800T Series
Models: XL280, XL380, XL381,
and XL390

Button Board Cover (Internet Zone and Status Lights)

Note: Illustrations may show parts removed that are not part of this procedure. It is necessary to remove only the parts listed in the written procedure.

To remove the button board cover, complete the following steps:

1. Prepare the Notebook for disassembly ([pg 10](#)).
2. Open the display and squeeze the sides of the display assembly hinge covers while sliding them off the hinges.

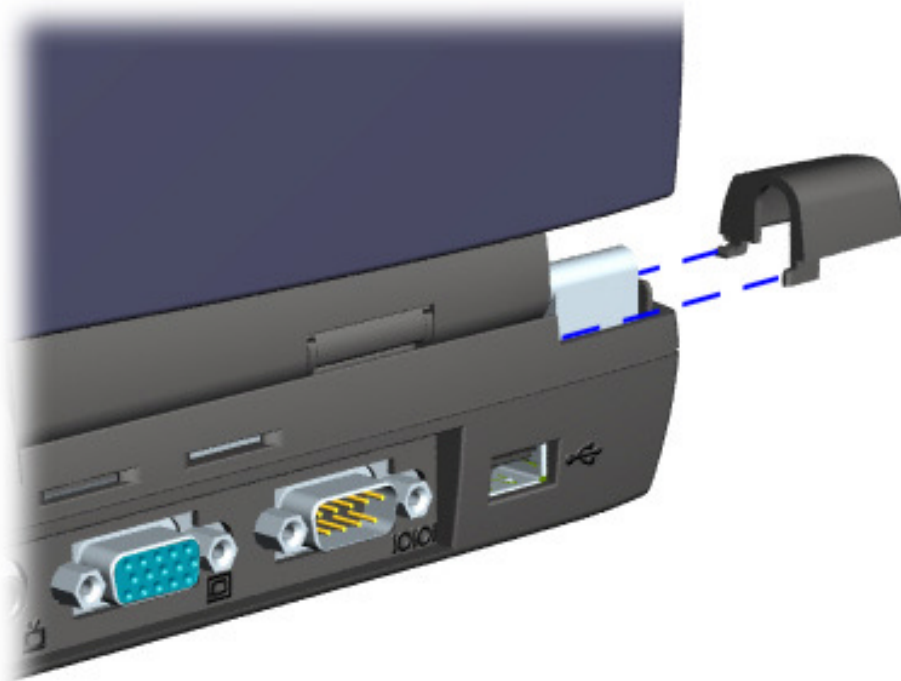

Continued on the next page.

maintenance & service guide

Presario 1800/1800T Series

Models: XL280, XL380, XL381,
and XL390

3. Remove the two innermost screws from the display assembly hinges that secure the button board cover to the chassis.

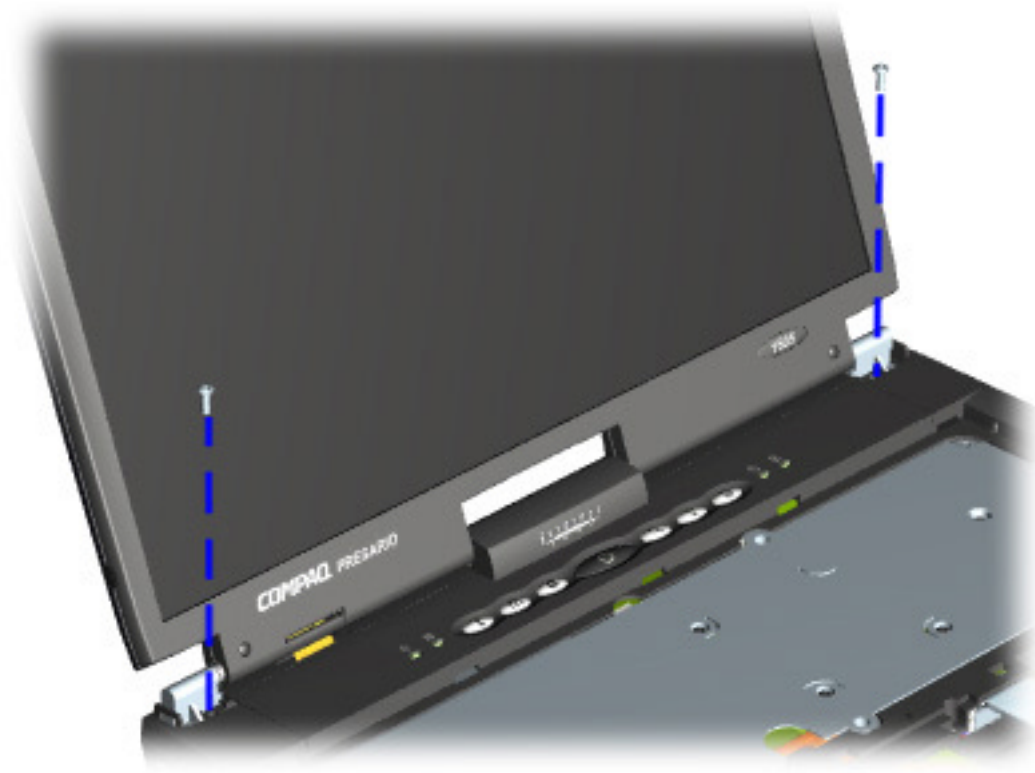

Continued on the next page.

maintenance & service guide

Presario 1800/1800T Series

Models: XL280, XL380, XL381,
and XL390

4. Turn the unit upside down and remove the two screws (shown below) located near the back that secure the button board cover to the chassis.

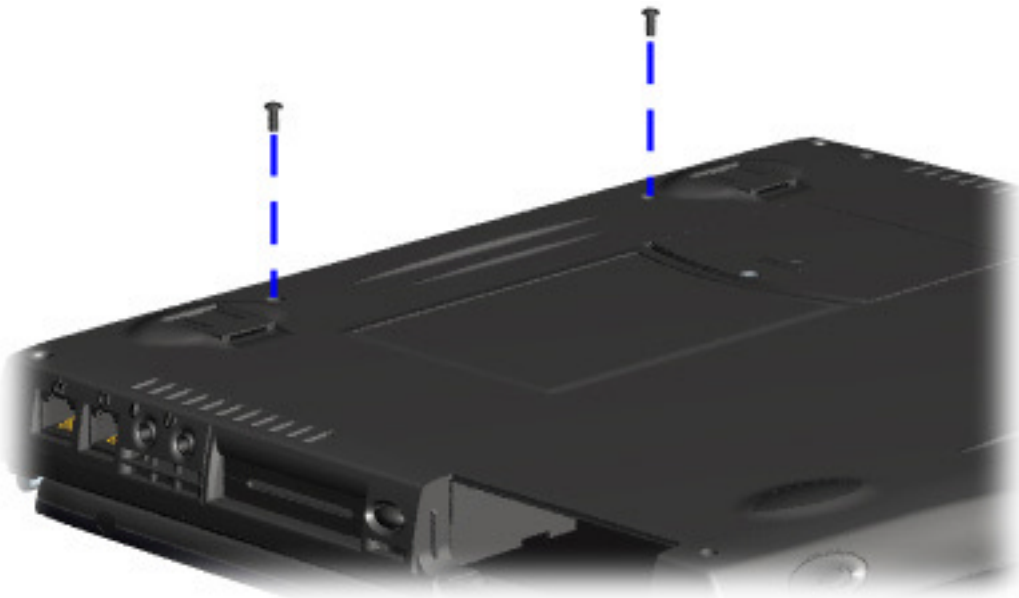

Continued on the next page.

maintenance & service guide

Presario 1800/1800T Series

Models: XL280, XL380, XL381,
and XL390

5. Turn the unit right side up and open the display.
6. Lift up one corner of the button board cover and push forward from the back (center piece) to release the snaps ①.
7. Lift and remove the cover from the chassis ②.

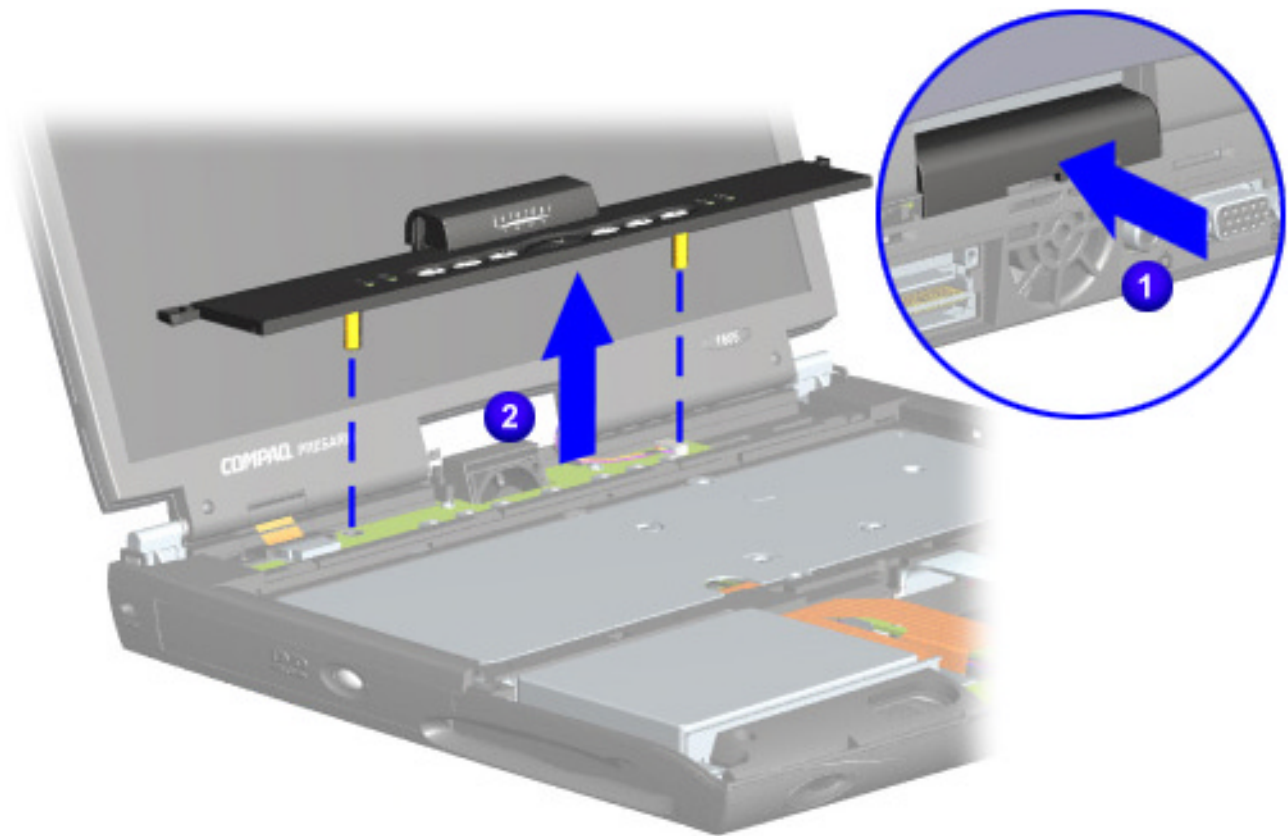

To replace the button board cover, reverse these procedures.

Presario 1800/1800T Series Models: XL280, XL380, XL381, and XL390

Internet Switch Board

Note: Illustrations may show parts removed that are not part of this procedure. It is necessary to remove only the parts listed in the written procedure.

To remove the Internet switch board, complete the following steps:

1. Prepare the Notebook for disassembly ([pg 10](#)).
2. Remove the button board cover ([pg 17](#)).
3. Remove the screw securing the display flex cable bracket and lift off the bracket ❶.
4. Disconnect the display flex cable from the connector on the system board ❷.
5. Disconnect the backlight cable from the connector on the Internet switch board ❸.

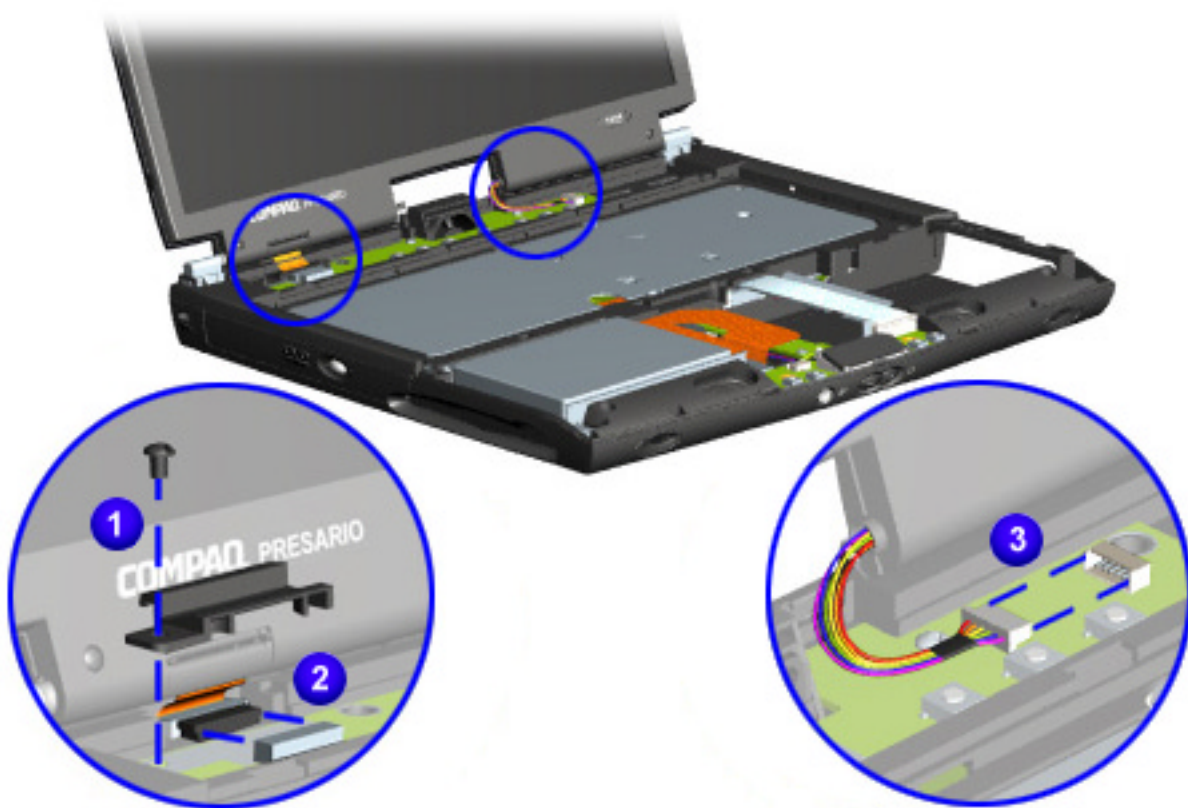

Continued on the next page.

maintenance & service guide

Presario 1800/1800T Series

Models: XL280, XL380, XL381,
and XL390

6. Remove the two screws securing the Internet switch board and lift it from the chassis.

Note: The 15-in. standard and high resolution (SXGA) display panels have unique Internet switch boards that are not interchangeable. If disassembling more than one Notebook, keep each Internet switch board with the correct Notebook.

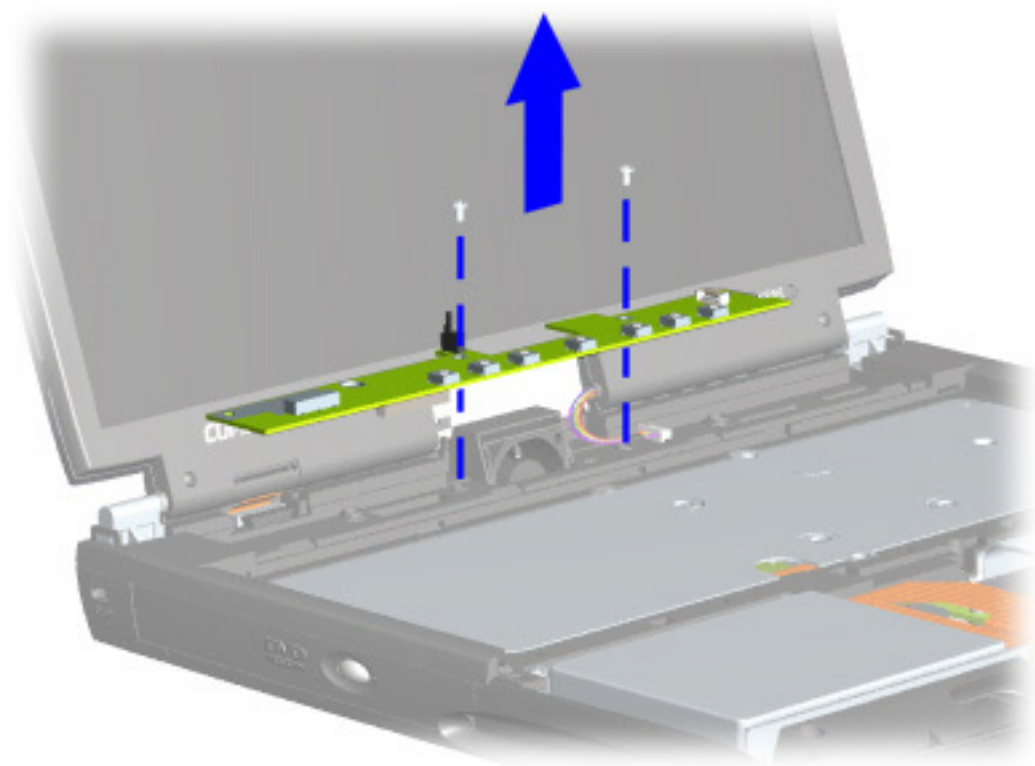

To replace the Internet switch board, reverse these procedures.

Presario 1800/1800T Series
Models: XL280, XL380, XL381,
and XL390

Heat Sink (Heatspreader)

To remove the heat sink, complete the following steps:

1. Prepare the Notebook for disassembly ([pg 10](#)).
2. Remove the Palmrest cover with TouchPad ([pg 13](#)).
3. Remove the keyboard ([pg 16](#)).
4. Remove six screws from the heat sink and lift it out of the chassis.

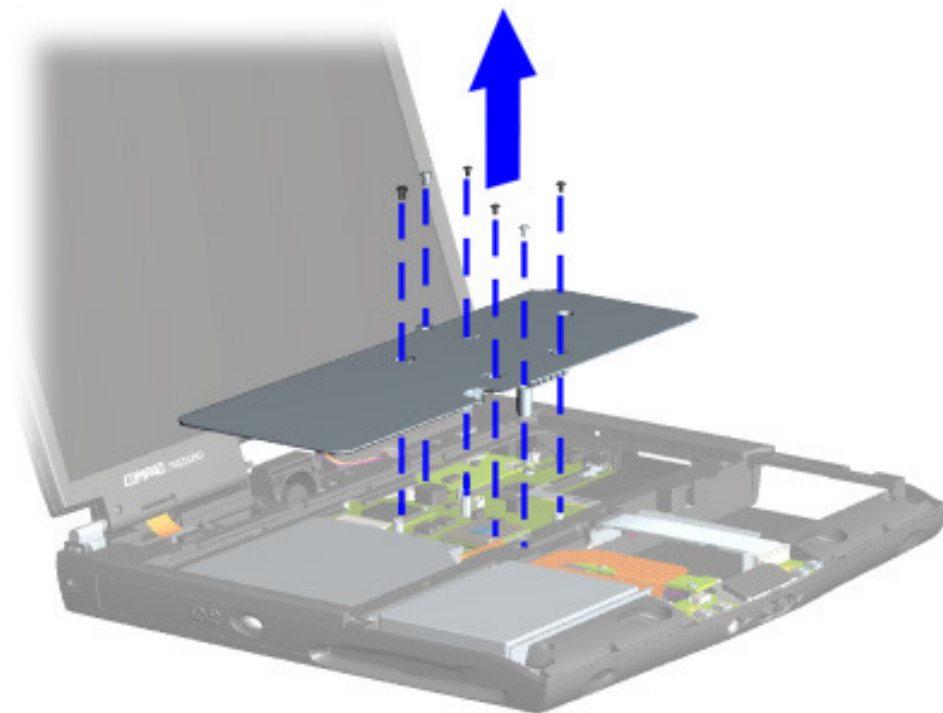

To replace the heat sink, reverse these procedures.

 **CAUTION:** To prevent damage, do not use excessive pressure when replacing screws.

Note: If the thermal pads on the heat sink are missing or damaged, install a new heat sink.

Important: Before installing the new heat sink, remove the plastic covering from the thermal pads.

maintenance & service guide

Presario 1800/1800T Series
Models: XL280, XL380, XL381,
and XL390

Modem

To remove the modem, complete the following steps:

1. Prepare the Notebook for disassembly ([pg 10](#)).
2. Remove the Palmrest cover with TouchPad ([pg 13](#)).
3. Remove the keyboard ([pg 16](#)).
4. Remove the button board cover ([pg 17](#)).
5. Remove the heat sink ([pg 23](#)).
6. Disconnect the modem cable from the connector on the modem board ①.
7. Remove the three screws from the modem board and remove the modem by lifting the front edge, sliding it towards you, and then lifting the modem off the system board ②.

Note: The CPU cover prevents lifting the modem straight up from the system board.

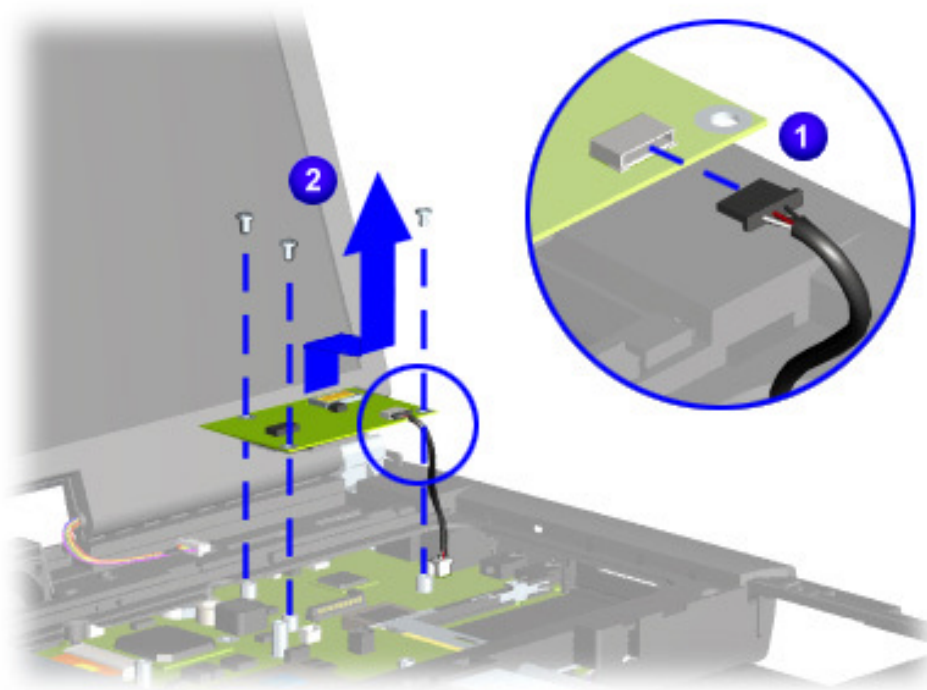

To replace the modem board, reverse these procedures.

maintenance & service guide

Presario 1800/1800T Series
Models: XL280, XL380, XL381,
and XL390

Hard Drive

Note: Illustrations may show parts removed that are not part of this procedure. It is necessary to remove only the parts listed in the written procedure.

To remove the hard drive, complete the following steps:

1. Prepare the Notebook for disassembly ([pg 10](#)).
2. Remove the Palmrest cover with TouchPad ([pg 13](#)).
3. Disconnect the [hard drive data cable](#).

Note: Do not pull on the ribbon cable. Remove the cable from the back of the hard drive using the plastic connector attached to the cable.

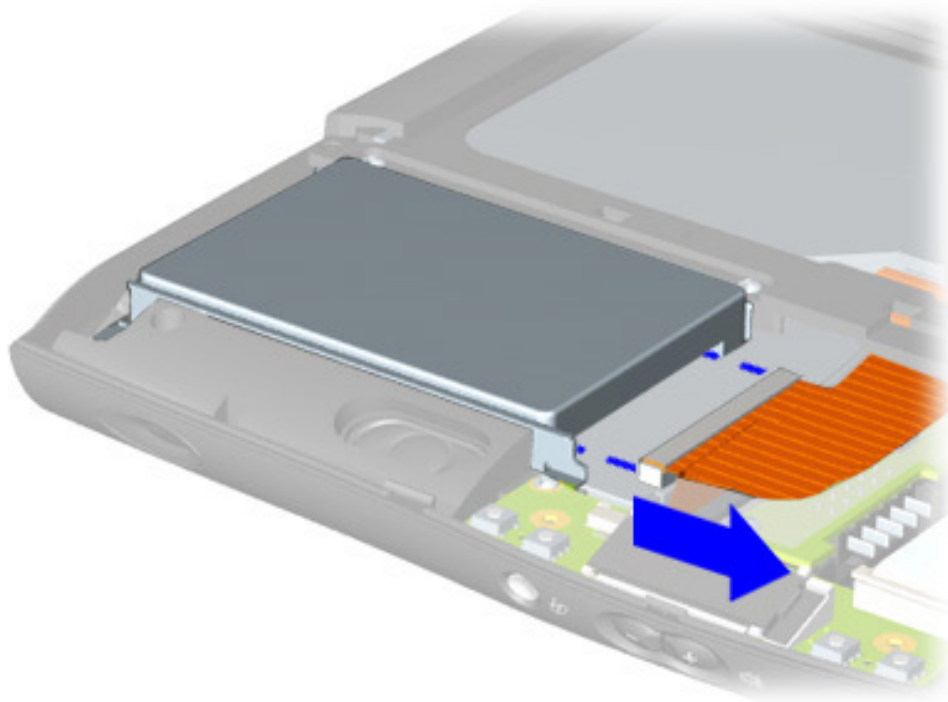

Continued on the next page.

maintenance & service guide

Presario 1800/1800T Series
Models: XL280, XL380, XL381,
and XL390

4. Remove three screws from the hard drive mounting bracket.
5. Lift out the hard drive with drive mounting brackets attached.

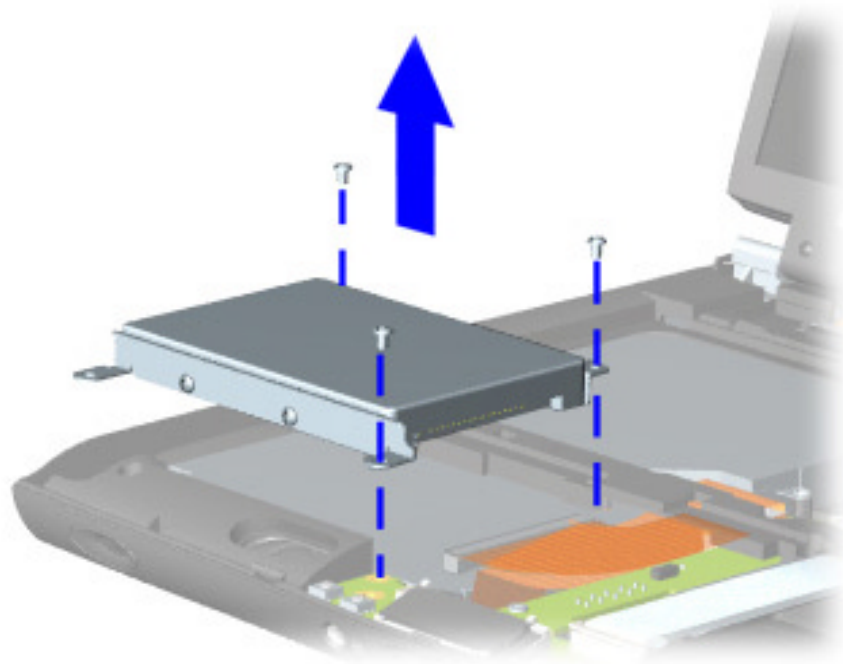

CAUTION: The hard drive unit is susceptible to shock and must not be dropped or allowed to experience any rough treatment. Handle the hard drive with extreme care.

Continued on the next page.

maintenance & service guide

Presario 1800/1800T Series

Models: XL280, XL380, XL381,
and XL390

6. To remove the hard drive mounting brackets, remove the two screws from each of side of the hard drive.

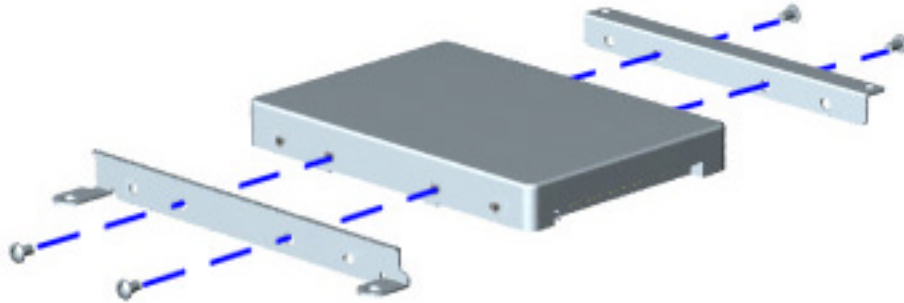

To replace the hard drive and mounting brackets, reverse these procedures.

Presario 1800/1800T Series
Models: XL280, XL380, XL381,
and XL390

LCD DisqPlay Module

Note: Illustrations may show parts removed that are not part of this procedure. It is necessary to remove only the parts listed in the written procedure.

To remove the LCD DisqPlay Module, complete the following steps:

1. Prepare the Notebook for disassembly ([pg 10](#)).
2. Remove the Palmrest cover with TouchPad ([pg 13](#)).
3. Remove the hard drive ([pg 25](#)).
4. Disconnect the flex cable from the DisqPlay module ❶.
5. Lift and remove the DisqPlay module from the chassis ❷.

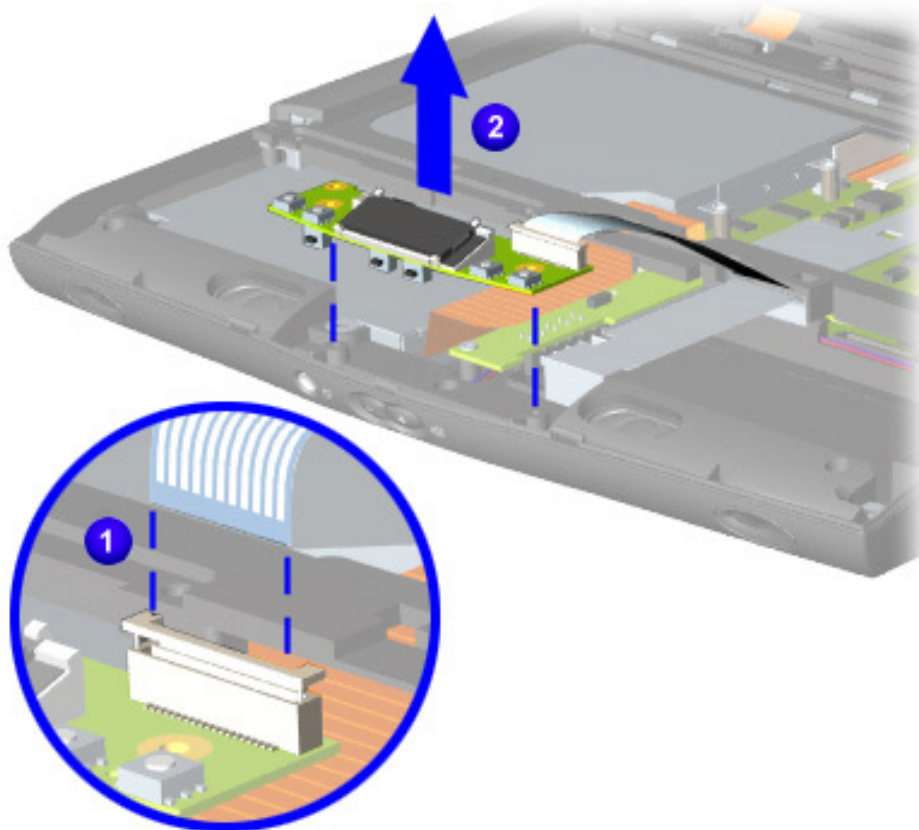

To replace the LCD DisqPlay module, reverse these procedures.

maintenance & service guide

Presario 1800/1800T Series
Models: XL280, XL380, XL381,
and XL390

Processor

To remove the processor, complete the following steps:

1. Prepare the Notebook for disassembly ([pg 10](#)).
2. Remove the Palmrest cover with TouchPad ([pg 13](#)).
3. Remove the keyboard ([pg 16](#)).
4. Remove the heat sink ([pg 23](#)).

Note: These Notebooks are equipped with one of two different types of processors. Match the processor in the unit with the correct procedure before attempting to remove it.

5. If the processor matches the image below, complete step **a**. However, if the processor matches the image shown on the next page, skip to step **b**.
 - a. Place tip of standard screwdriver in center slot, twist screwdriver toward "Free" until it snaps ①, and lift processor from the chassis ②.

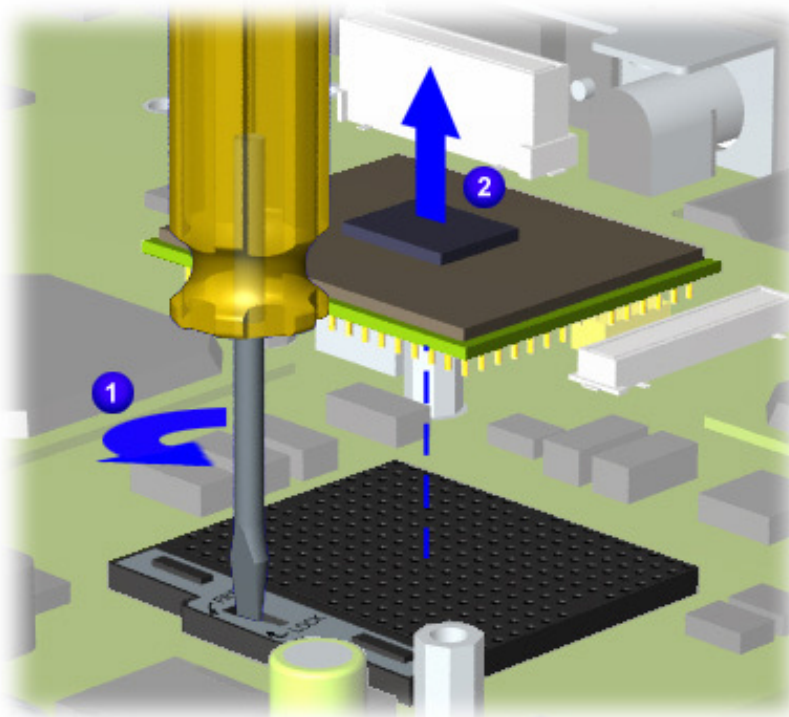

Continued on the next page.

maintenance & service guide

Presario 1800/1800T Series

Models: XL280, XL380, XL381,
and XL390

- b. With standard screwdriver, turn screw counter-clockwise toward "0" ① and lift processor from the chassis ②.

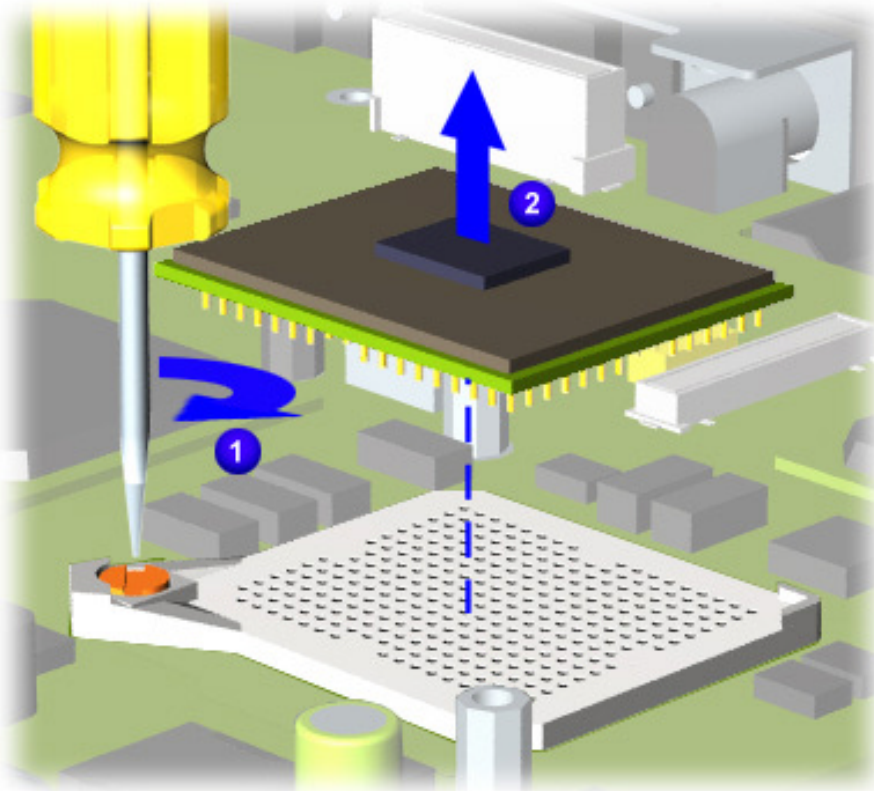

To replace the processor, complete the following steps:

1. Fully align the processor pins with the socket holes on the connector.
2. Press down carefully on the processor directly over the connector to seat the it.
3. Once the processor is in place, reassemble the remaining subassemblies by reversing their removal procedures.

maintenance & service guide

Presario 1800/1800T Series
Models: XL280, XL380, XL381,
and XL390

CD, CD-RW, or DVD Drive

To remove the CD, CD-RW, or DVD Drive, complete the following steps:

1. Prepare the Notebook for disassembly ([pg 10](#)).
2. Remove the Palmrest cover with TouchPad ([pg 13](#)).
3. Remove the keyboard ([pg 16](#)).
4. Remove the heat sink ([pg 23](#)).
5. Turn the unit upside down and remove the two screws that secure the CD/DVD drive to the chassis.

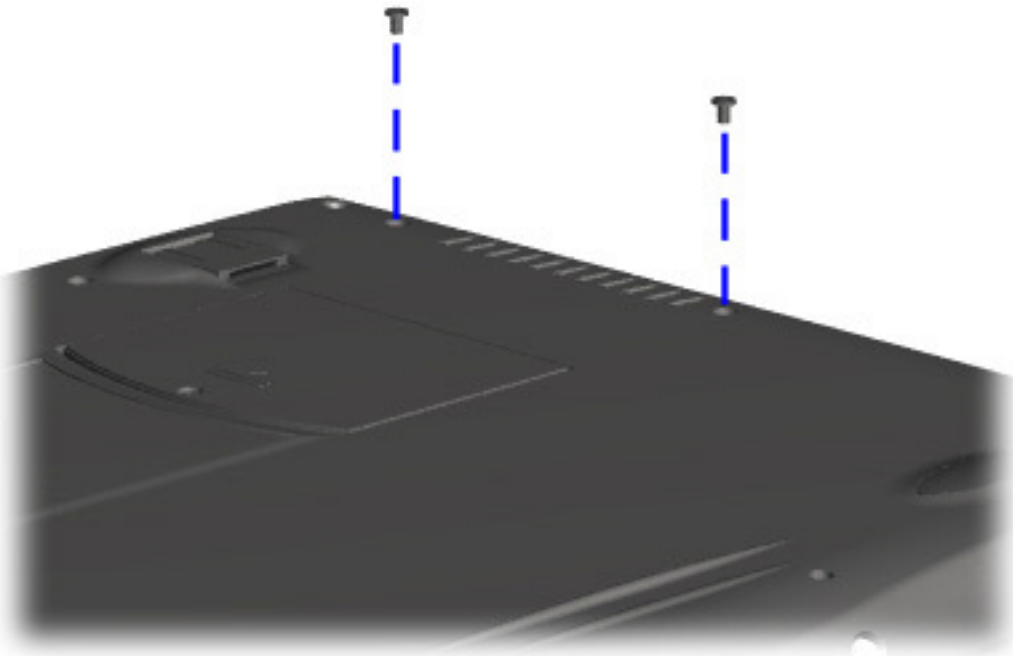

Continued on the next page.

maintenance & service guide

Presario 1800/1800T Series
Models: XL280, XL380, XL381,
and XL390

6. Turn the unit over (right side up) and open the display.
7. Remove the two screws located at the back of the CD/DVD drive.

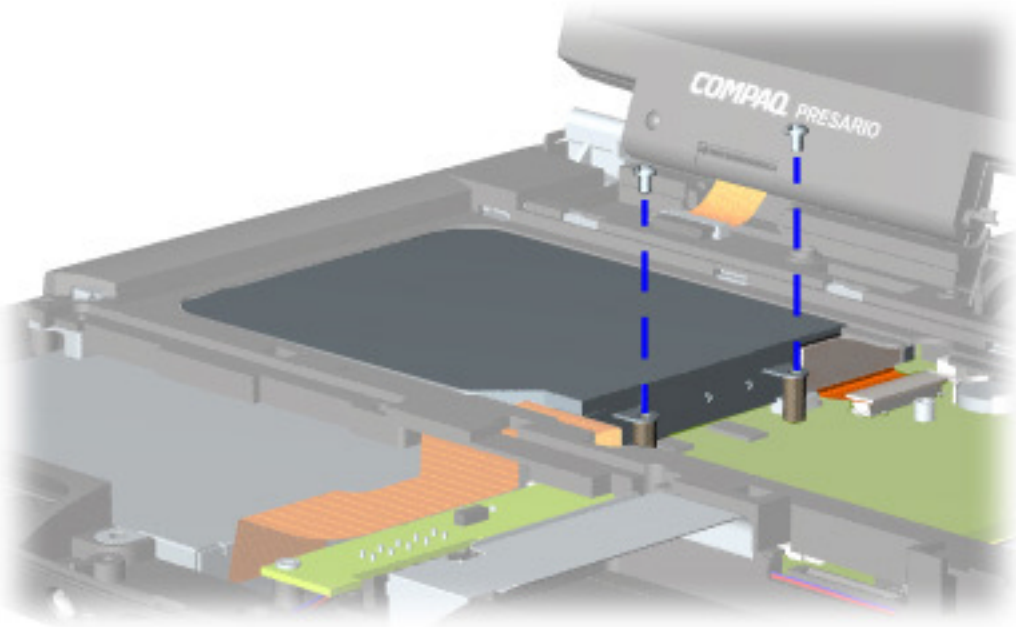

Continued on the next page.

maintenance & service guide

Presario 1800/1800T Series

Models: XL280, XL380, XL381,
and XL390

8. Disconnect the CD/DVD drive cable and push forward from the back of the drive to slide it out of the chassis.

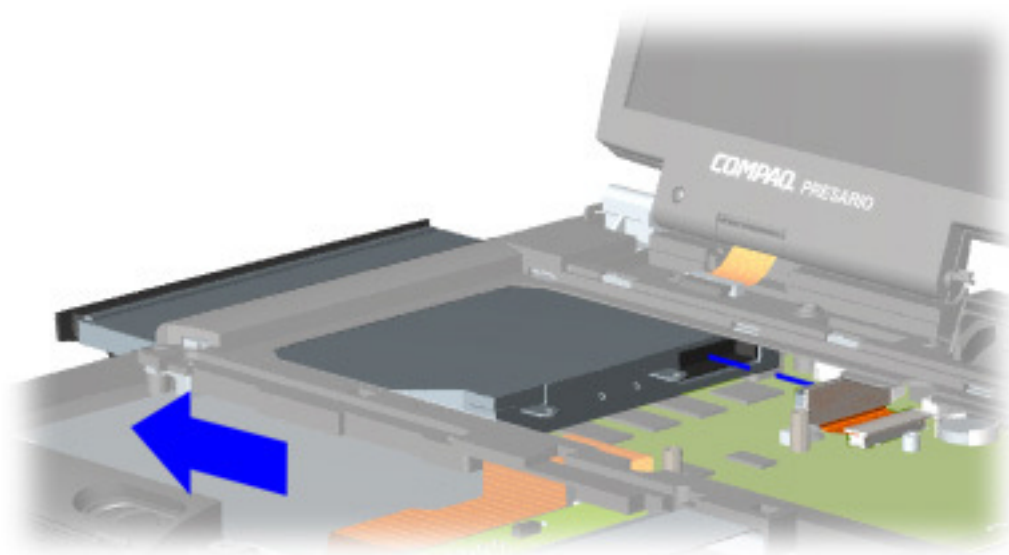

To replace the CD, CD-RW, or DVD drive, reverse these procedures.

CAUTION: When replacing the CD/DVD drive, ensure that the [CD/DVD Ribbon Cable](#) is placed in its proper location during the reassembly process. Improper cable placement can damage the Notebook.

maintenance & service guide

Presario 1800/1800T Series
Models: XL280, XL380, XL381,
and XL390

Display Panel Assembly

Note: Illustrations may show parts removed that are not part of this procedure. It is necessary to remove only the parts listed in the written procedure.

To remove the display panel assembly, complete the following steps:

1. Prepare the Notebook for disassembly ([pg 10](#)).
2. Remove the button board cover ([pg 17](#)).
3. Remove the screw securing the display flex cable bracket and lift off the bracket ❶.
4. Disconnect the display flex cable from the connector on the system board ❷.
5. Disconnect the backlight cable from the connector on the Internet switch board ❸.

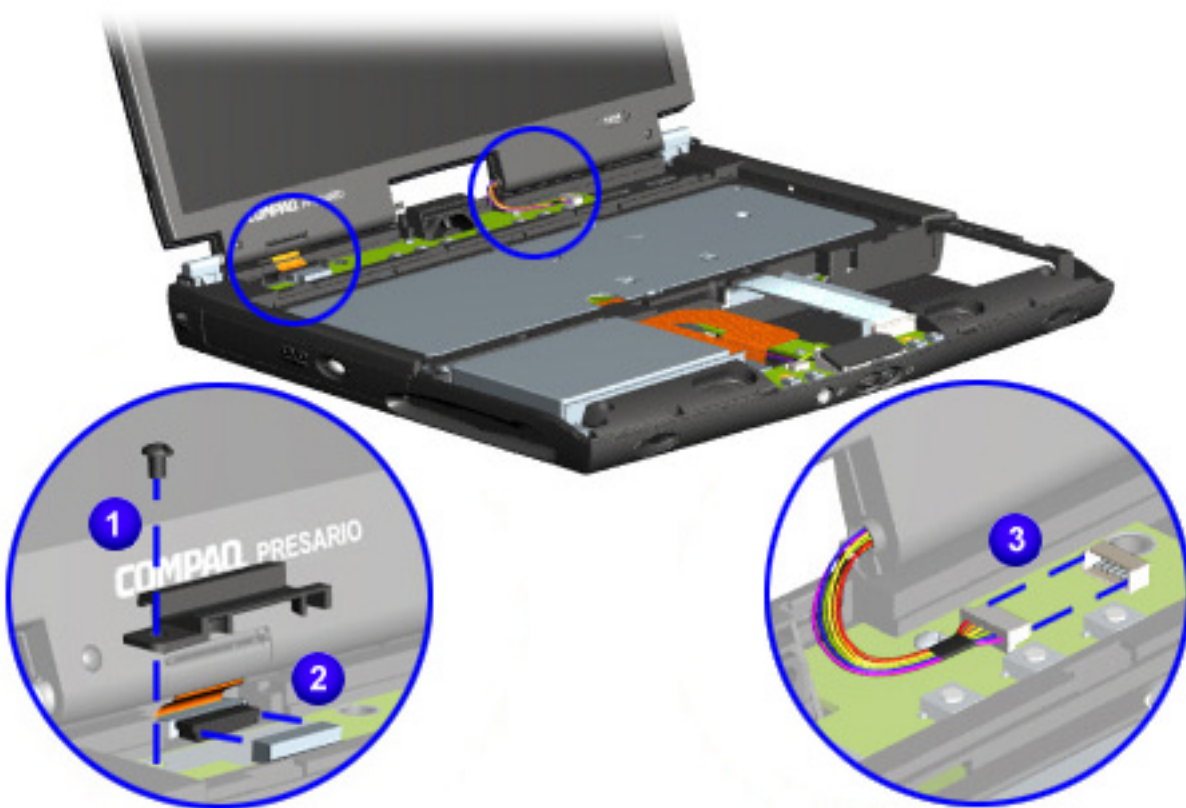

Continued on the next page.

maintenance & service guide

Presario 1800/1800T Series
Models: XL280, XL380, XL381,
and XL390

6. Remove the two outermost screws from the display assembly hinges.

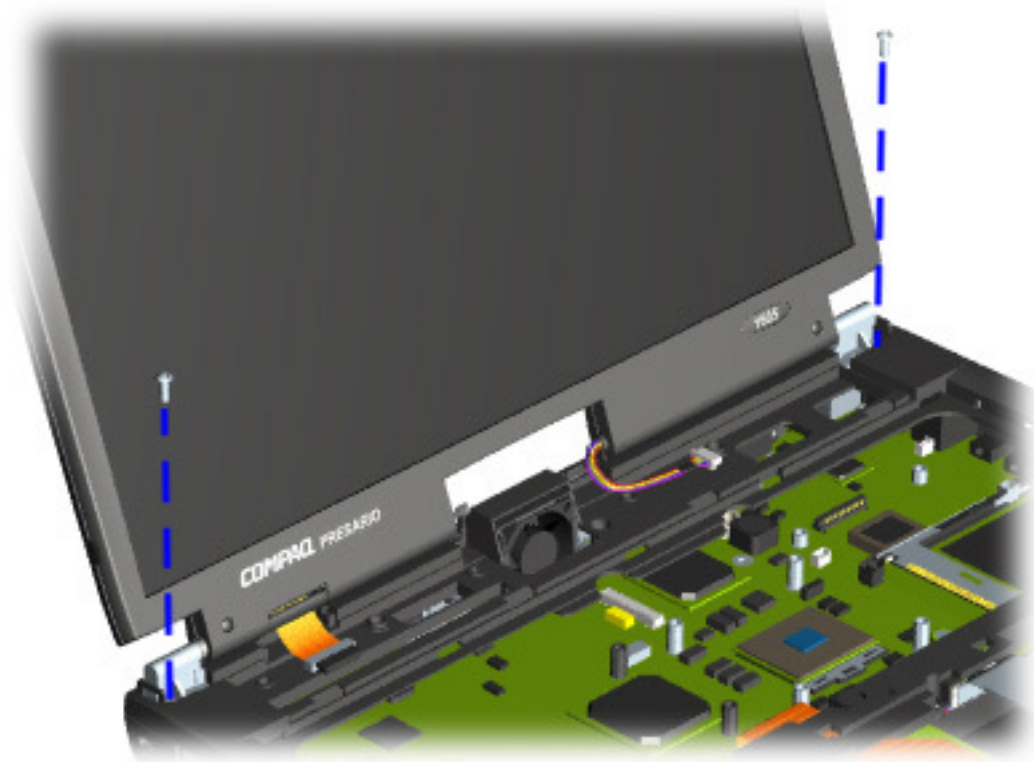

CAUTION: Support the display while removing the screws to prevent dropping and damaging the display.

Continued on the next page.

maintenance & service guide

Presario 1800/1800T Series
Models: XL280, XL380, XL381,
and XL390

7. Lift the display assembly off the hinges.



To replace the display panel assembly, reverse these procedures.

Presario 1800/1800T Series
Models: XL280, XL380, XL381,
and XL390

Upper CPU Cover

To remove the upper CPU cover, complete the following steps:

1. Prepare the Notebook for disassembly ([pg 10](#)).
2. Remove the Palmrest cover with TouchPad ([pg 13](#)).
3. Remove the keyboard ([pg 16](#)).
4. Remove the heat sink ([pg 23](#)).
5. Remove the button board cover ([pg 17](#)).
6. Remove the Internet switch board ([pg 21](#)).
7. Remove the hard drive ([pg 25](#)).
8. Remove the display panel assembly ([pg 34](#)).
9. Remove the four screws (shown) located on the top of the upper CPU cover and lift the cover off the chassis.

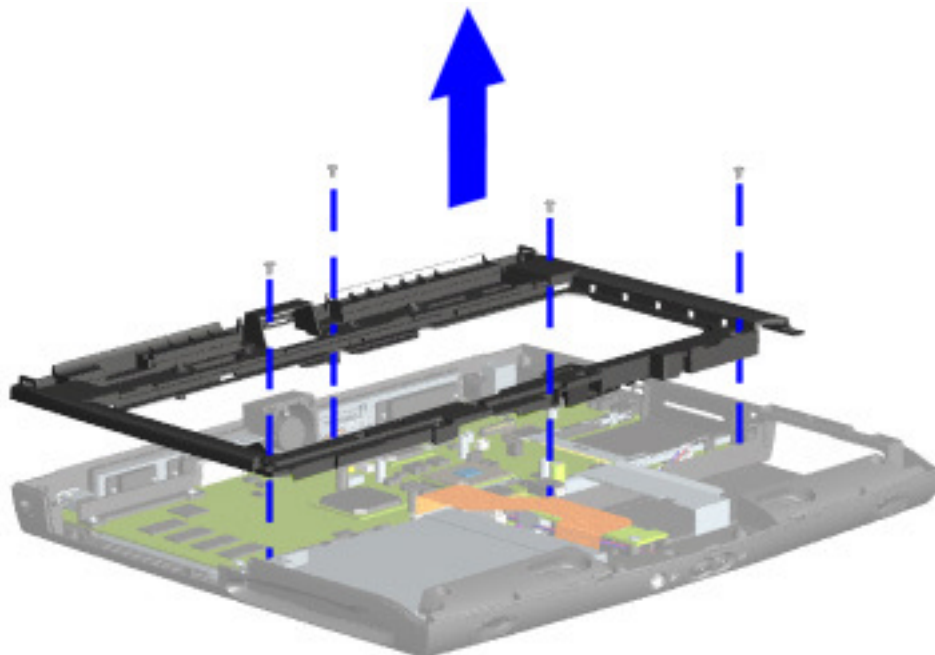

To replace the upper CPU cover, reverse these procedures.

Presario 1800/1800T Series
Models: XL280, XL380, XL381,
and XL390

Fan Assembly

To remove the fan assembly, complete the following steps:

1. Prepare the Notebook for disassembly ([pg 10](#)).
2. Remove the Palmrest cover with TouchPad ([pg 13](#)).
3. Remove the keyboard ([pg 16](#)).
4. Remove the heat sink ([pg 23](#)).
5. Remove the button board cover ([pg 17](#)).
6. Remove the Internet switch board ([pg 21](#)).
7. Remove the display panel assembly ([pg 34](#)).
8. Remove the hard drive ([pg 25](#)).
9. Remove the upper CPU cover ([pg 37](#)).
10. Lift the fan assembly from the chassis slot, and disconnect the fan cable from the connector on the system board.

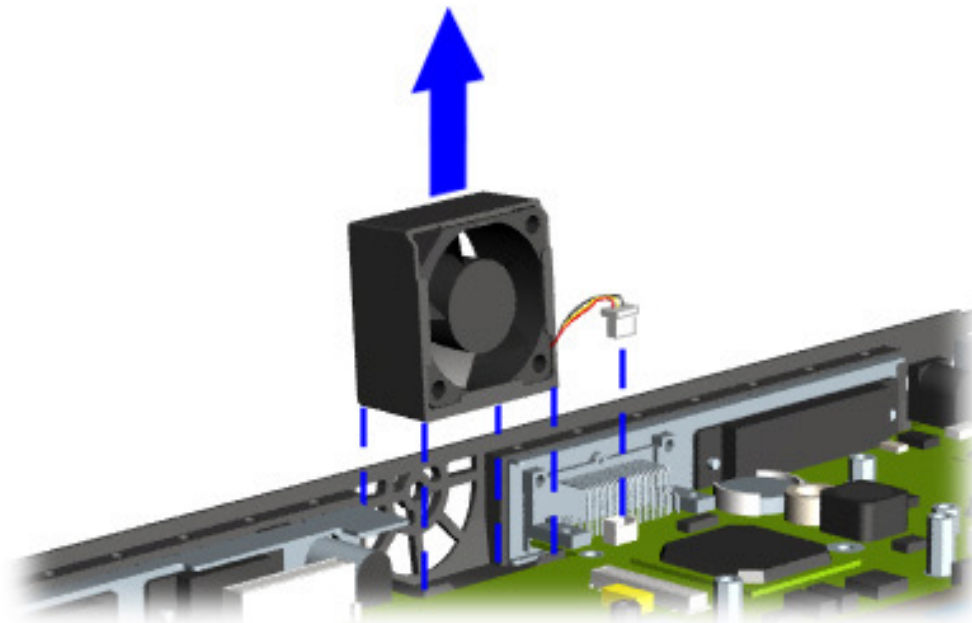

Continued on the next page.

maintenance & service guide

Presario 1800/1800T Series

Models: XL280, XL380, XL381,
and XL390

To remove the fan gasket, pull the gasket from the exterior of the fan.

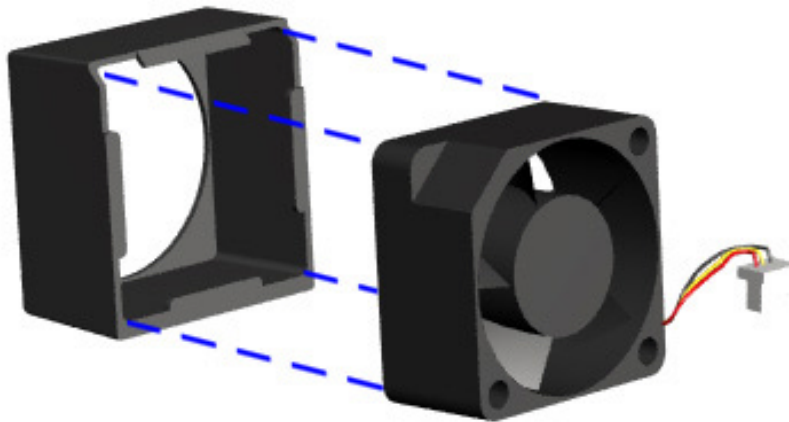

To replace the fan assembly and gasket, reverse these procedures.

Important: When replacing the fan assembly, be sure that the side with the manufacturer's label is facing toward the interior of the Notebook (the fan blades should be seen from the exterior and air should blow into the Notebook).

maintenance & service guide

Presario 1800/1800T Series
Models: XL280, XL380, XL381,
and XL390

Real Time Clock (RTC) Battery

 **CAUTION:** Removing the RTC battery clears the power-on password and removes all setup attributes that are programmed in the CMOS.

To remove the RTC battery, complete the following steps:

1. Prepare the Notebook for disassembly ([pg 10](#)).
2. Remove the Palmrest cover with TouchPad ([pg 13](#)).
3. Remove the keyboard ([pg 16](#)).
4. Remove the heat sink ([pg 23](#)).
5. Remove the button board cover ([pg 17](#)).
6. Remove the Internet switch board ([pg 21](#)).
7. Remove the display panel assembly ([pg 34](#)).
8. Remove the hard drive ([pg 25](#)).
9. Remove the upper CPU cover ([pg 37](#)).

Continued on the next page.

maintenance & service guide

Presario 1800/1800T Series

Models: XL280, XL380, XL381,
and XL390

10. Locate the RTC battery on the system board to the right of the CD/DVD drive near the rear edge of the chassis.
11. Using your fingers or a *non-metallic* object, gently pry up the RTC battery ① and lift it out of the battery socket ②.

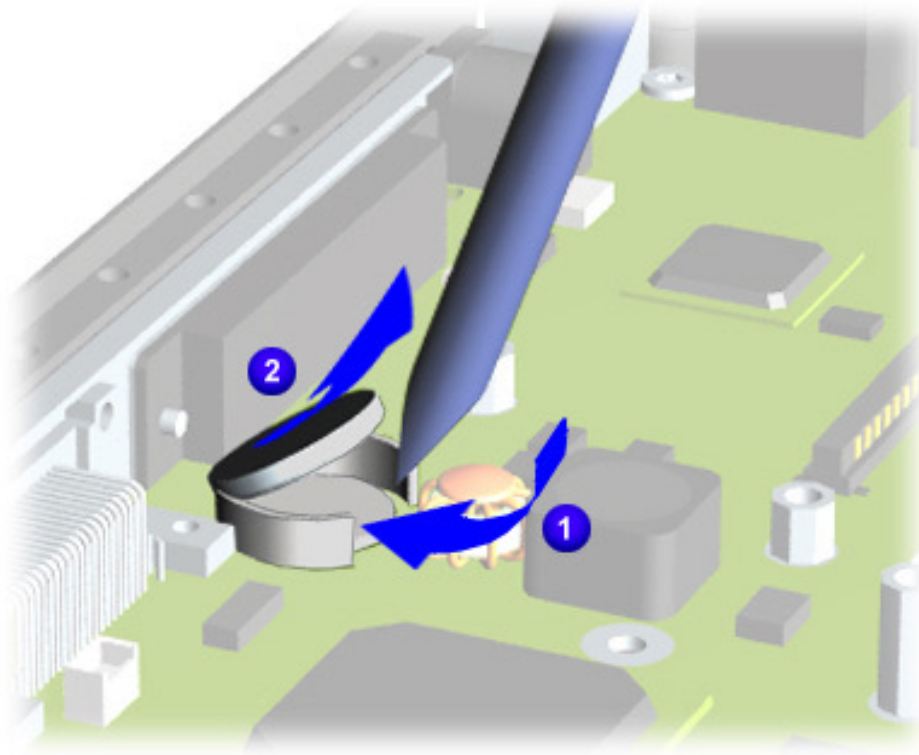

Note: If you are clearing the CMOS attributes, keep the battery out for at least 10 seconds before replacing it.

To replace the RTC battery, press the battery firmly into the socket, and reassemble the remaining components by reversing their removal procedures.

Presario 1800/1800T Series
Models: XL280, XL380, XL381,
and XL390

Diskette Drive

To remove the diskette drive, complete the following steps:

1. Prepare the Notebook for disassembly ([pg 10](#)).
2. Remove the Palmrest cover with TouchPad ([pg 13](#)).
3. Remove the keyboard ([pg 16](#)).
4. Remove the heat sink ([pg 23](#)).
5. Remove the CD, CD-RW or DVD Drive ([pg 31](#)).
6. Remove the button board cover ([pg 17](#)).
7. Remove the Internet switch board ([pg 21](#)).
8. Remove the display panel assembly ([pg 34](#)).
9. Remove the hard drive ([pg 25](#)).
10. Remove the upper CPU cover ([pg 37](#)).
11. Remove screw from the diskette drive retaining bracket and lift off the bracket.

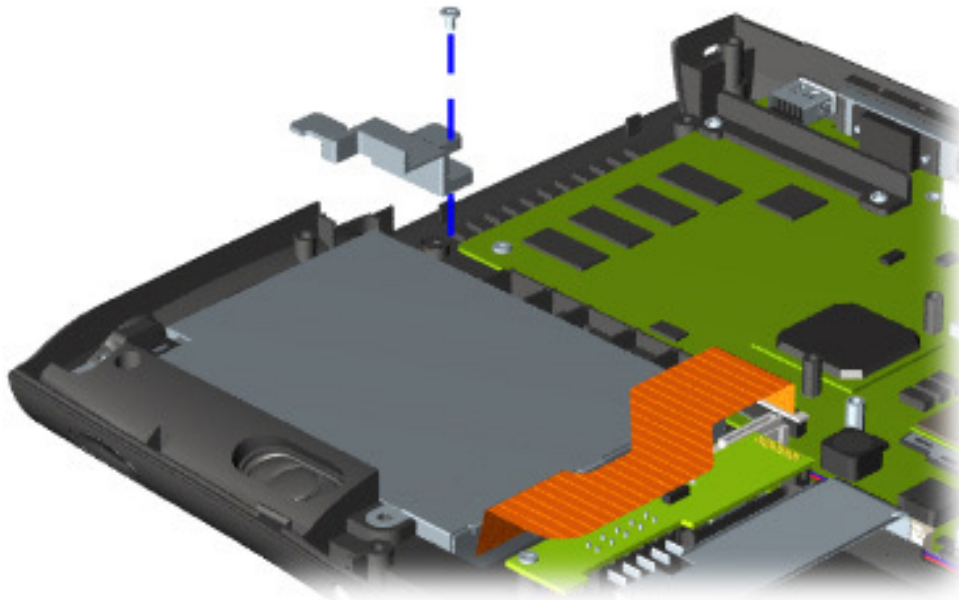

Continued on the next page.

maintenance & service guide

Presario 1800/1800T Series

Models: XL280, XL380, XL381,
and XL390

12. Disconnect the [diskette drive data cable](#) from the [ZIF Connector](#) on the system board **1**.
13. Remove the screw that secures the diskette drive to the chassis, and lift the drive from the chassis **2**.

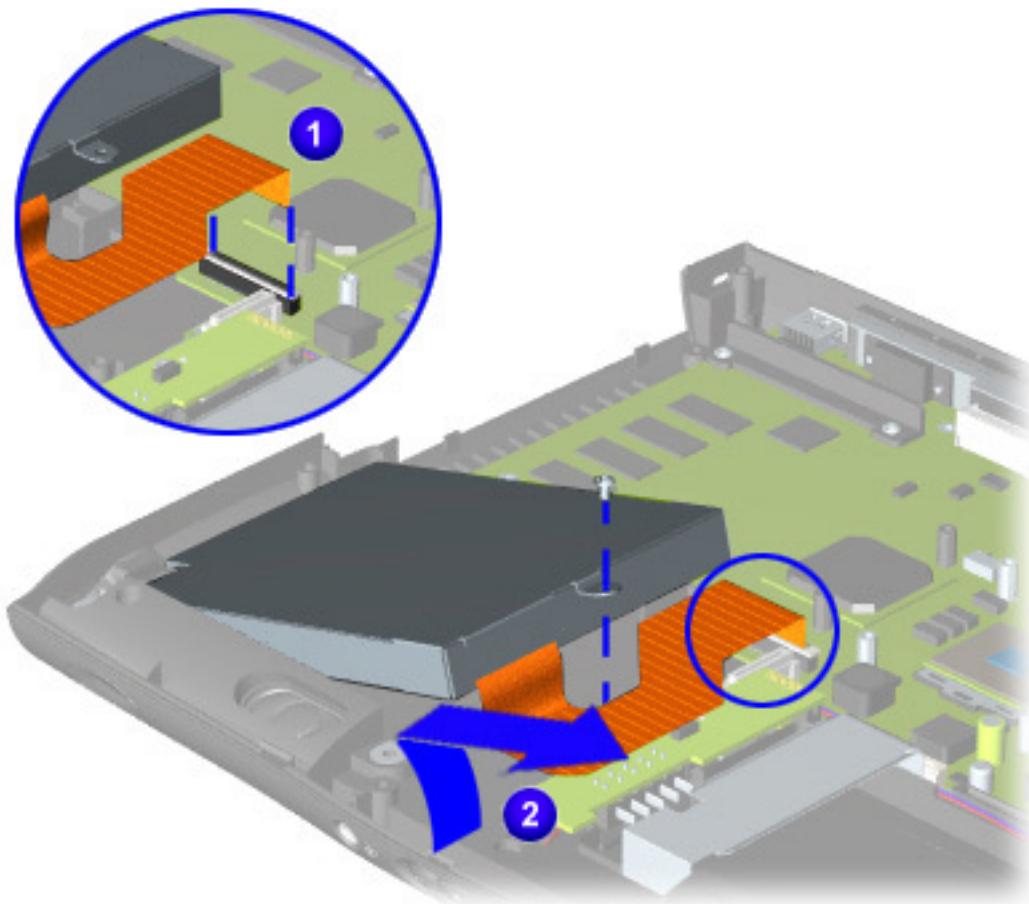

To replace the diskette drive, reverse these procedures.

CAUTION: When replacing the diskette drive, make sure that the [Diskette Drive Ribbon Cable](#) is placed in its proper location during the reassembly process. Improper cable placement can damage the Notebook.

Presario 1800/1800T Series Models: XL280, XL380, XL381, and XL390

Voltage Converter Board

To remove the voltage converter board, complete the following steps:

1. Prepare the Notebook for disassembly ([pg 10](#)).
2. Remove the Palmrest cover with TouchPad ([pg 13](#)).
3. Remove the keyboard ([pg 16](#)).
4. Remove the heat sink ([pg 23](#)).
5. Remove the button board cover ([pg 17](#)).
6. Remove the Internet switch board ([pg 21](#)).
7. Remove the display panel assembly ([pg 34](#)).
8. Remove the hard drive ([pg 25](#)).
9. Remove the upper CPU cover ([pg 37](#)).
10. Remove the two screws (shown below) securing the voltage converter board.
11. Lift the voltage converter board off the connector on the system board.

Note: Retain the plastic insulator for reassembly with the replacement board.

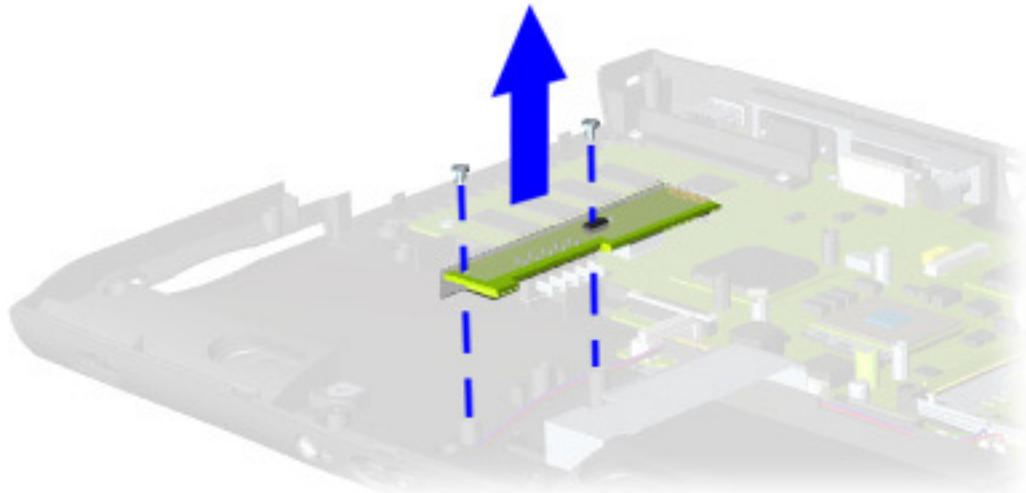

To replace the voltage converter board, reverse these procedures.

Note: When replacing the voltage converter board, ensure that the pins are aligned with the connector on the system board.

maintenance & service guide

Presario 1800/1800T Series
Models: XL280, XL380, XL381,
and XL390

Speaker Assembly

To remove the speaker assembly, complete the following steps:

1. Prepare the Notebook for disassembly ([pg 10](#)).
2. Remove the Palmrest cover with TouchPad ([pg 13](#)).
3. Remove the keyboard ([pg 16](#)).
4. Remove the heat sink ([pg 23](#)).
5. Remove the button board cover ([pg 17](#)).
6. Remove the Internet switch board ([pg 21](#)).
7. Remove the display panel assembly ([pg 34](#)).
8. Remove the hard drive ([pg 25](#)).
9. Remove the upper CPU cover ([pg 37](#)).
10. Remove the voltage converter board ([pg 44](#)).

Continued on the next page.

maintenance & service guide

Presario 1800/1800T Series
Models: XL280, XL380, XL381,
and XL390

11. Disconnect the speaker cables from the system board and lift the speaker assembly from the chassis.

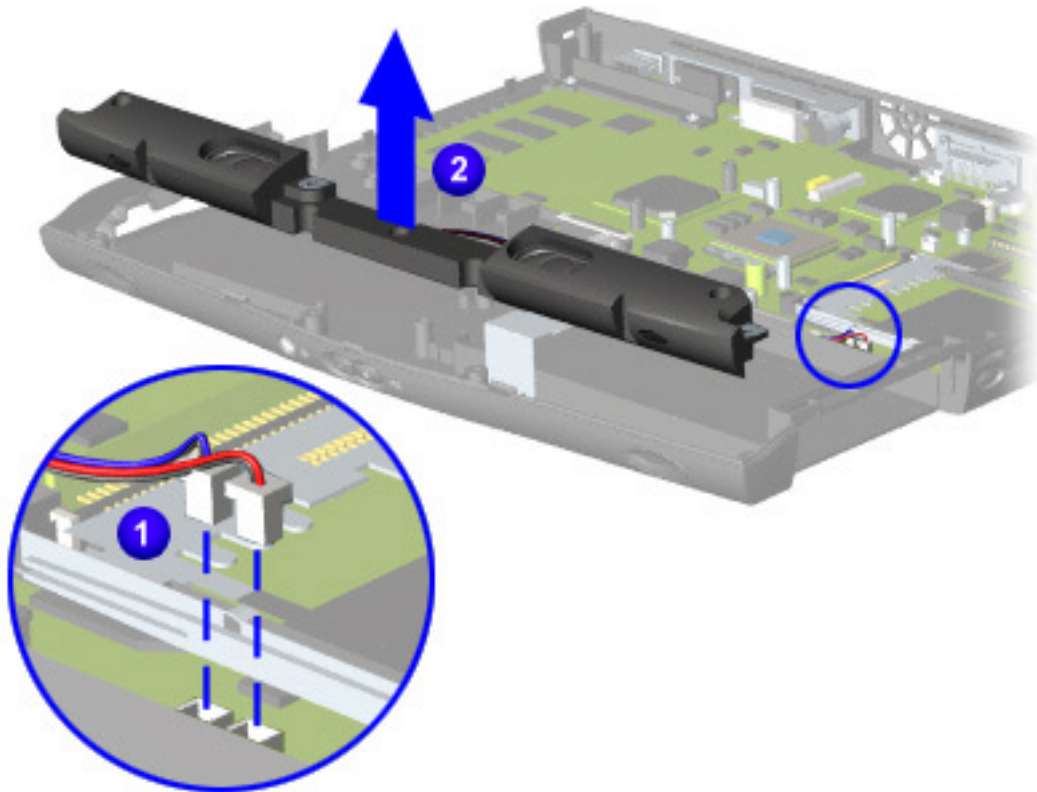

To replace the speaker assembly, reverse these procedures.

CAUTION: When replacing the diskette drive, make sure that the [Speaker Assembly Cable](#) is placed in its proper location during the reassembly process. Improper cable placement can damage the Notebook.

maintenance & service guide

Presario 1800/1800T Series
Models: XL280, XL380, XL381,
and XL390

System Board

To remove the system board, complete the following steps:

1. Prepare the Notebook for disassembly ([pg 10](#)).
2. Remove the Palmrest cover with TouchPad ([pg 13](#)).
3. Remove the keyboard ([pg 16](#)).
4. Remove the heat sink ([pg 23](#)).
5. Remove the button board cover ([pg 17](#)).
6. Remove the Internet switch board ([pg 21](#)).
7. Remove the display panel assembly ([pg 34](#)).
8. Remove the hard drive ([pg 25](#)).
9. Remove the upper CPU cover ([pg 37](#)).
10. Disconnect the LCD Display module cable from the system board ([pg 28](#)).
11. Remove the modem ([pg 24](#)).
12. Remove the CD, CD-RW, or DVD drive ([pg 31](#)).
13. Remove the fan assembly ([pg 38](#)).
14. Disconnect the diskette drive cable from the system board ([pg 43](#)).
15. Remove the voltage converter board ([pg 44](#)).
16. Disconnect the speaker assembly cables from the system board ([pg 46](#)).

Continued on the next page.

maintenance & service guide

Presario 1800/1800T Series

Models: XL280, XL380, XL381,
and XL390

17. Remove five standoffs (shown below) from the system board.

Note: The four remaining standoffs located on the system board may be left in place.

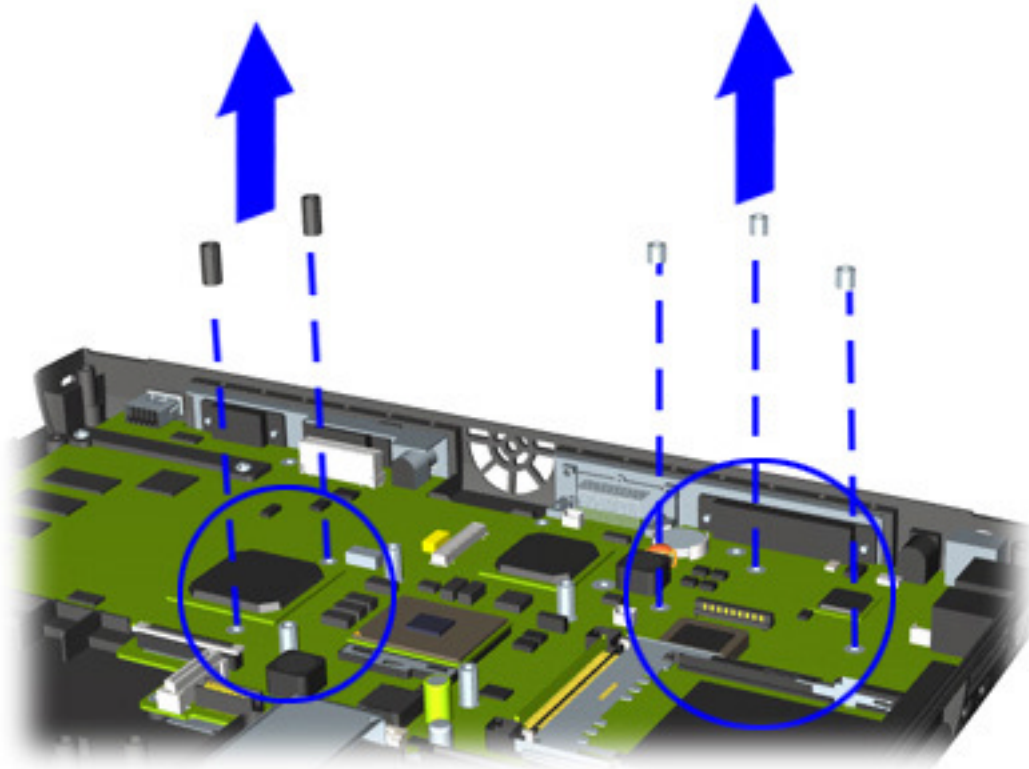

Continued on the next page.

maintenance & service guide

Presario 1800/1800T Series

Models: XL280, XL380, XL381,
and XL390

18. Remove the two screws from the CD/DVD drive mounting rail, and lift the mounting rail from the system board.

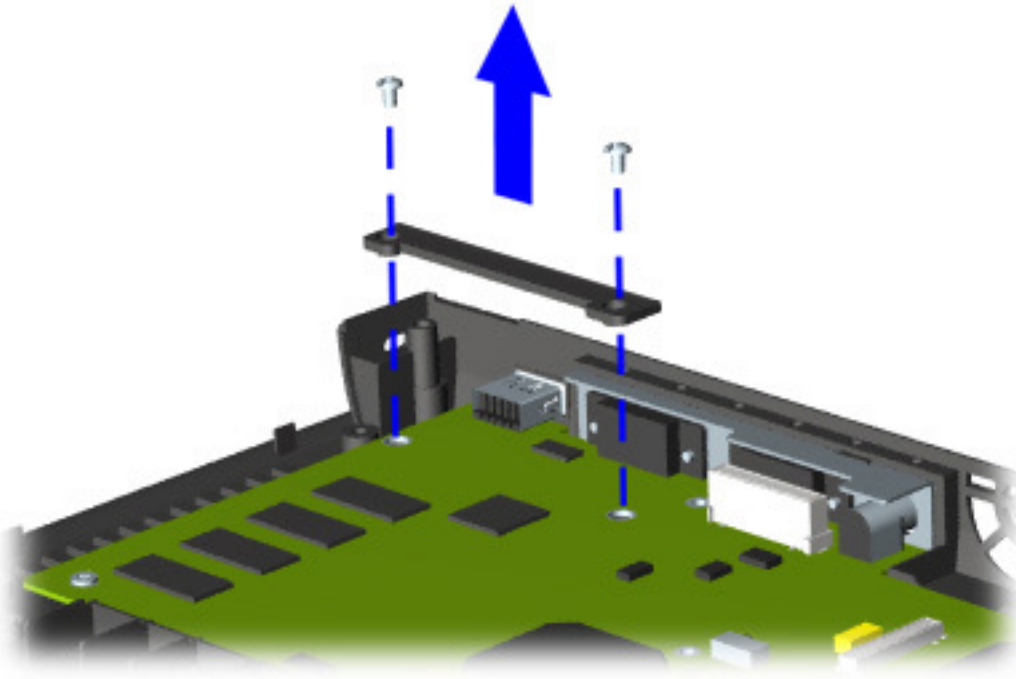

Continued on the next page.

maintenance & service guide

Presario 1800/1800T Series

Models: XL280, XL380, XL381,
and XL390

19. Remove four screws (shown below) from the system board.

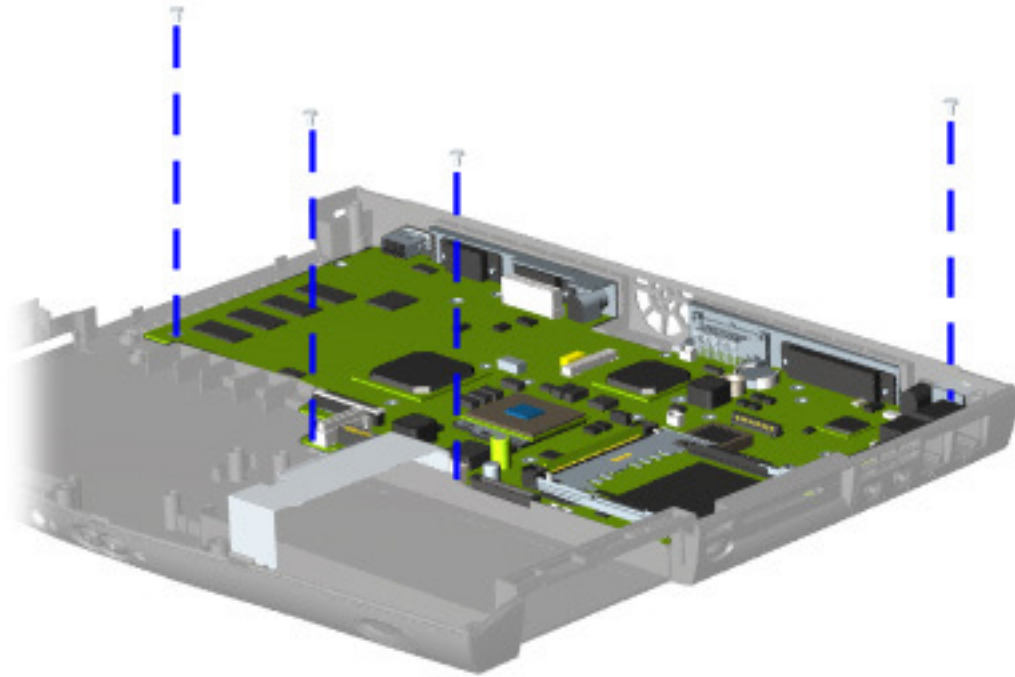

Note: The edges of the system board may be secured by shielded tape. This tape must be removed to free the system board.

Continued on the next page.

maintenance & service guide

Presario 1800/1800T Series

Models: XL280, XL380, XL381,
and XL390

20. Make sure that the PC card eject button is pushed inward **1**, and then lift up the front of the system board and pull it forward to remove it from the chassis **2**.

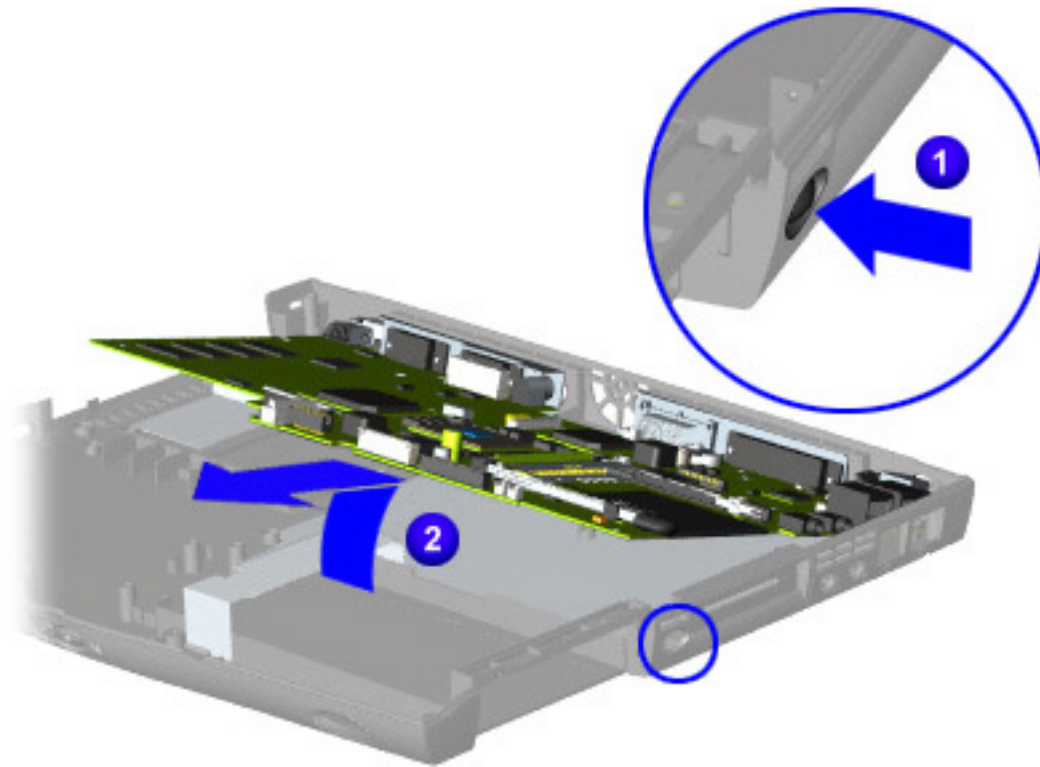

Important: Before replacing the system board, remove all remaining cables.

To replace the system board, reverse these procedures.

maintenance & service guide

Presario 1800/1800T Series
Models: XL280, XL380, XL381,
and XL390

Memory Module

To remove the memory module, complete the following steps:

1. Prepare the Notebook for disassembly ([pg 10](#)).
2. Close the display and turn the Notebook upside down.
3. Remove the screw (shown) from the memory module door.
4. With the front of the Notebook facing you, slide the memory module door to the left and lift it off.

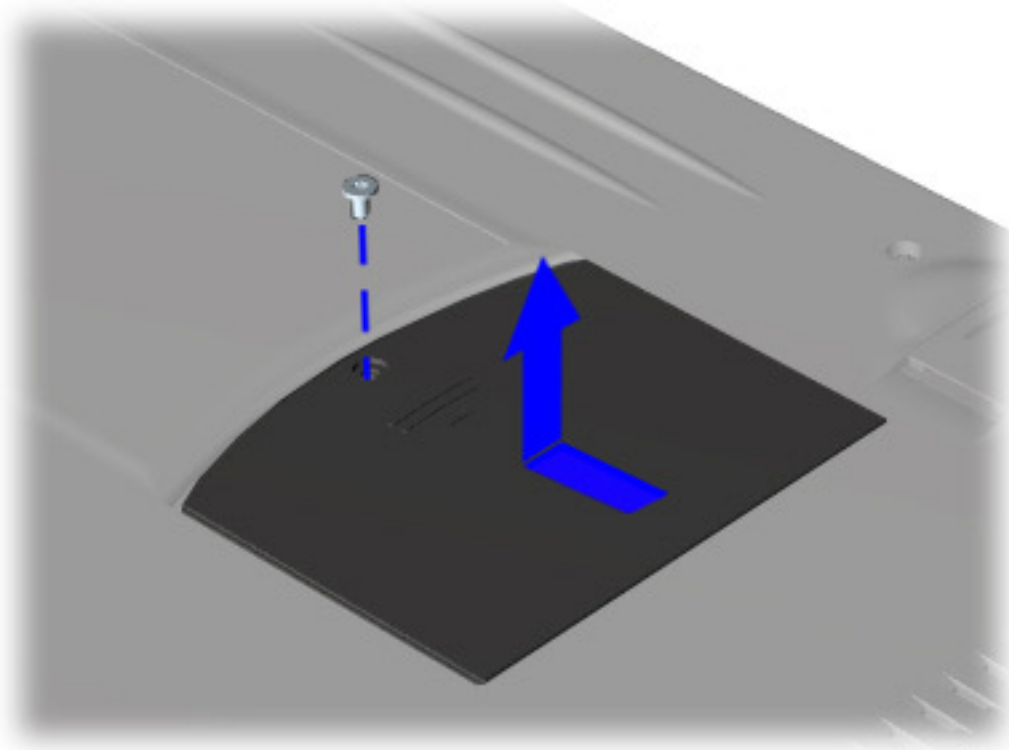

Continued on the next page.

maintenance & service guide

Presario 1800/1800T Series

Models: XL280, XL380, XL381,
and XL390

5. Pull the side levers to release the memory ①, and lift the memory module from the system board ②.

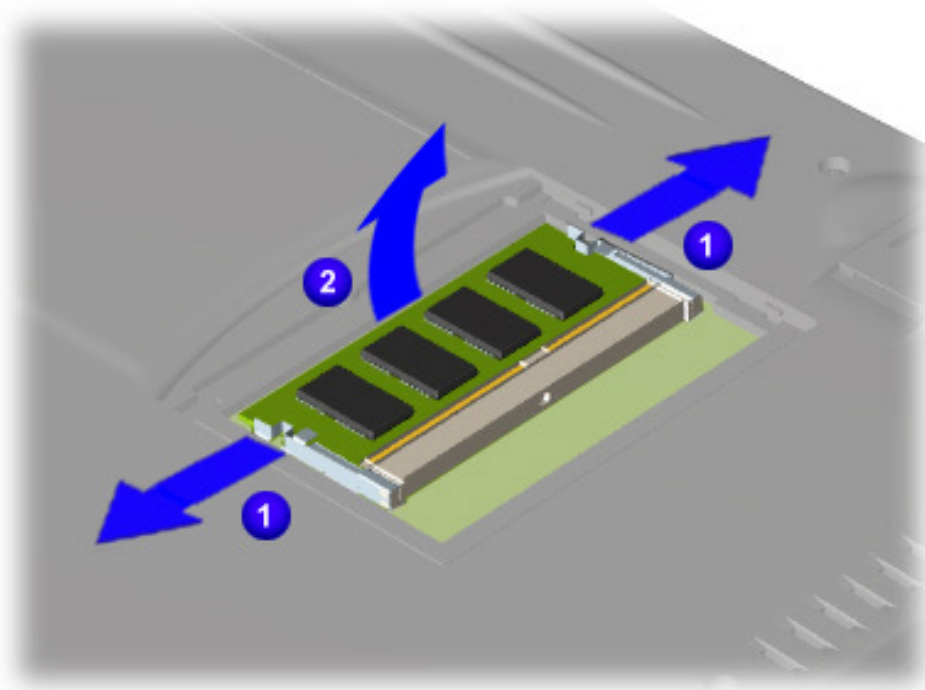

To replace the memory module, reverse these procedures.

maintenance & service guide

Presario 1800/1800T Series
Models: XL280, XL380, XL381,
and XL390

Parts Catalog

This chapter provides illustrations of the spare parts for Compaq Presario 1800XL Series Notebooks, and identifies the spare part ordering number and availability of each item.

Illustrated Parts

The following illustrations are typical of the spare parts provided with the Compaq Presario 1800XL Series Notebooks.

System Unit

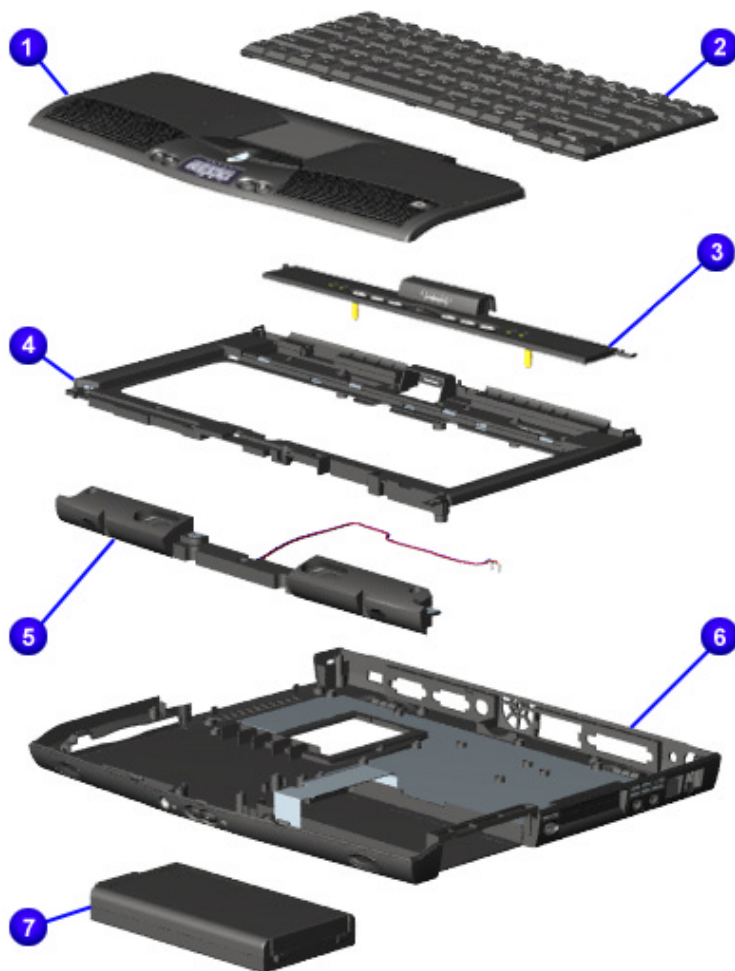

Spare Part Items

- ❶ Palmrest Cover with TouchPad Button Board
- ❷ Keyboard
- ❸ Top CPU Cover w/Power Switch
- ❹ Button Board Cover w/Internet Buttons
- ❺ Speakers, Enclosure, and Cables
- ❻ Enclosure Base
- ❼ Li-ion Enhanced Battery Pack

To order parts, refer to [Part Numbers & Availability](#) later in this chapter.

1.800.At.COMPAQ

maintenance & service guide

Presario 1800/1800T Series
Models: XL280, XL380, XL381,
and XL390

Boards

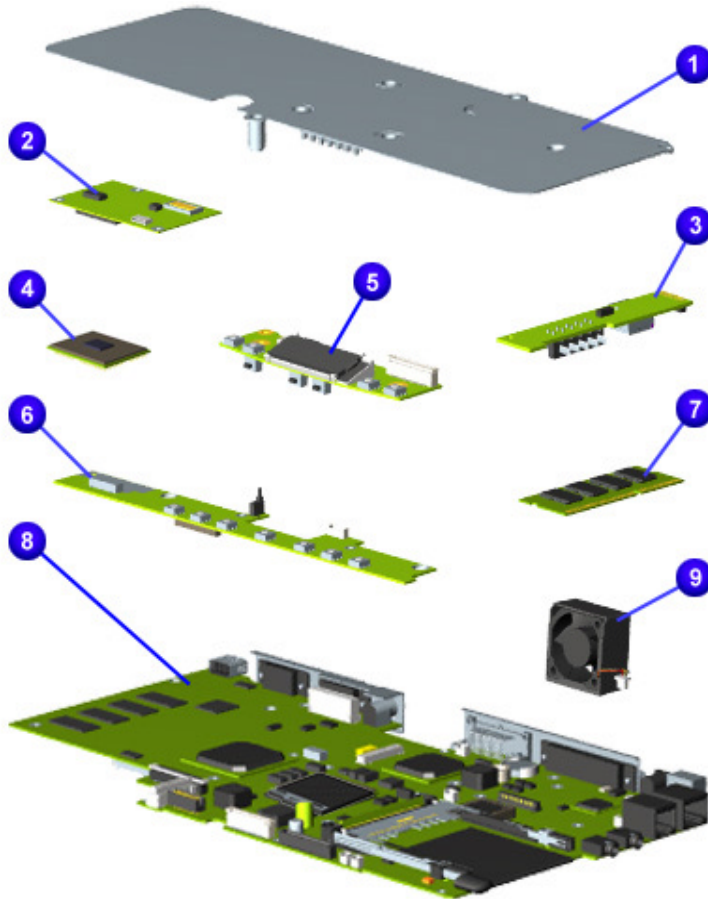

Spare Part Items

- | | |
|---|--|
| ❶ | Heat Sink |
| ❷ | Modem (56K Data/Fax w/o SRAM) |
| ❸ | Voltage Converter Board |
| ❹ | Processor (500-850 MHz/128-256K Cache/Pentium or Celeron) |
| ❺ | LCD Indicator (Display) Module |
| ❻ | Internet Switch Board (LCD or SXGA) |
| ❼ | Memory Extension Card (SO DIMM) |
| ❽ | System I/O Board with 64 MB SDRAM (with or without M3 Video-RAM) |
| ❾ | Fan Assembly |

To order parts, refer to [Part Numbers & Availability](#) later in this chapter.

maintenance & service guide

Presario 1800/1800T Series

Models: XL280, XL380, XL381,
and XL390

Display Assembly



Spare Part Item

Display Panel:
14.1 or 15.0-inch
TFT or TFT/SXGA (with LVDS, MD)

To order parts, refer to
[Part Numbers & Availability](#)
later in this chapter.

maintenance & service guide

Presario 1800/1800T Series

Models: XL280, XL380, XL381,
and XL390

Mass-Storage Devices

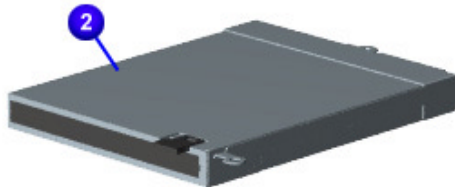
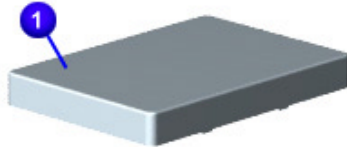

Spare Part Items

- | | |
|---|-----------------------------------|
| ❶ | Hard Drive (6.0 - 32.0 GB) |
| ❷ | Diskette Drive (1.44 MB) |
| ❸ | DVD Drive (6X or 8X) |
| ❹ | (not shown)
CD-ROM Drive (24X) |
| ❺ | (not shown)
CD-RW Drive |
| ❻ | (not shown)
DVD/CD-RW Combo |

To order parts, refer to [Part Numbers & Availability](#) later in this chapter.

maintenance & service guide

Presario 1800/1800T Series
Models: XL280, XL380, XL381,
and XL390

Miscellaneous Cable Kit

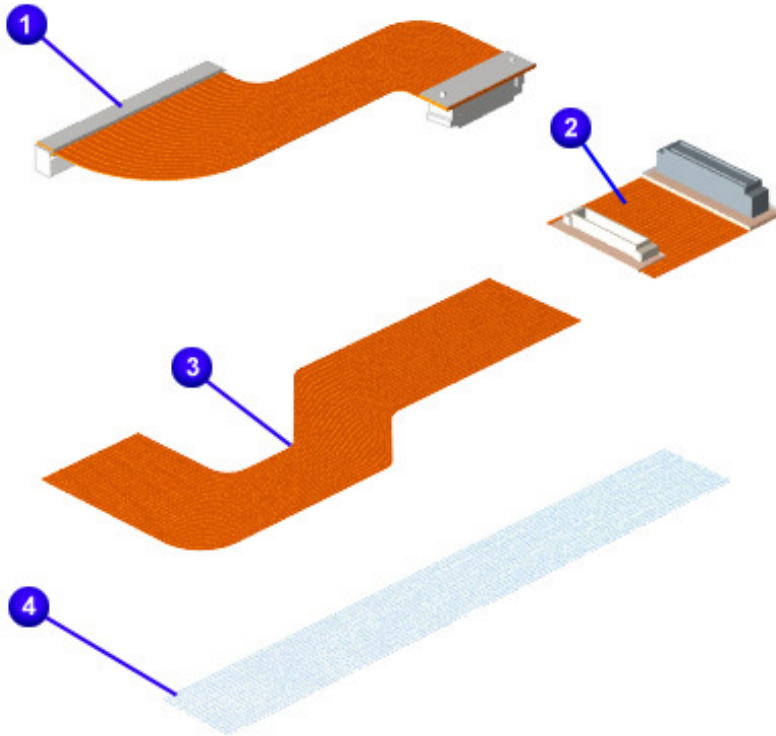

Spare Part Items

Miscellaneous Cable Kit*

- | | |
|---|----------------------------|
| ❶ | Hard Drive Cable |
| ❷ | CD/DVD Drive Cable |
| ❸ | Diskette Drive Cable |
| ❹ | Status Panel Cable |
| ❺ | (not shown) Modem Cable |
| ❻ | (not shown) TouchPad Cable |

*Kit includes one each of the above items.

To order parts, refer to [Part Numbers & Availability](#) later in this chapter.

Miscellaneous Hardware Kit

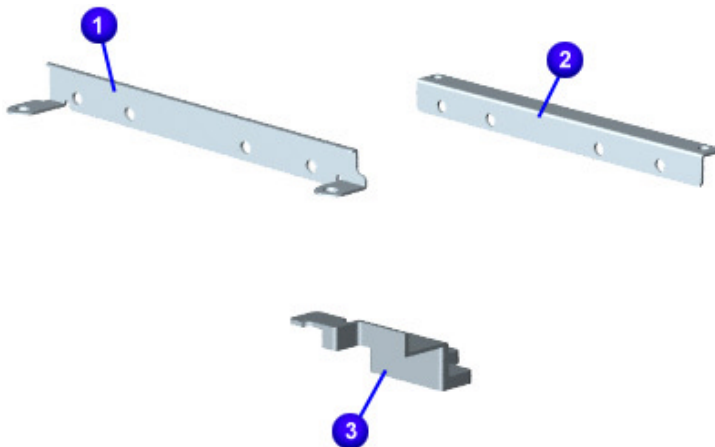

Spare Part Items

Miscellaneous Hardware Kit*

- | | |
|---|-------------------------------------|
| ❶ | Hard Drive Mounting Bracket (right) |
| ❷ | Hard Drive Mounting Bracket (left) |
| ❸ | Reinforcement Bracket |

*Kit includes one each of the above items.

To order parts, refer to [Part Numbers & Availability](#) later in this chapter.

maintenance & service guide

Presario 1800/1800T Series
Models: XL280, XL380, XL381,
and XL390

Miscellaneous Plastics Kit

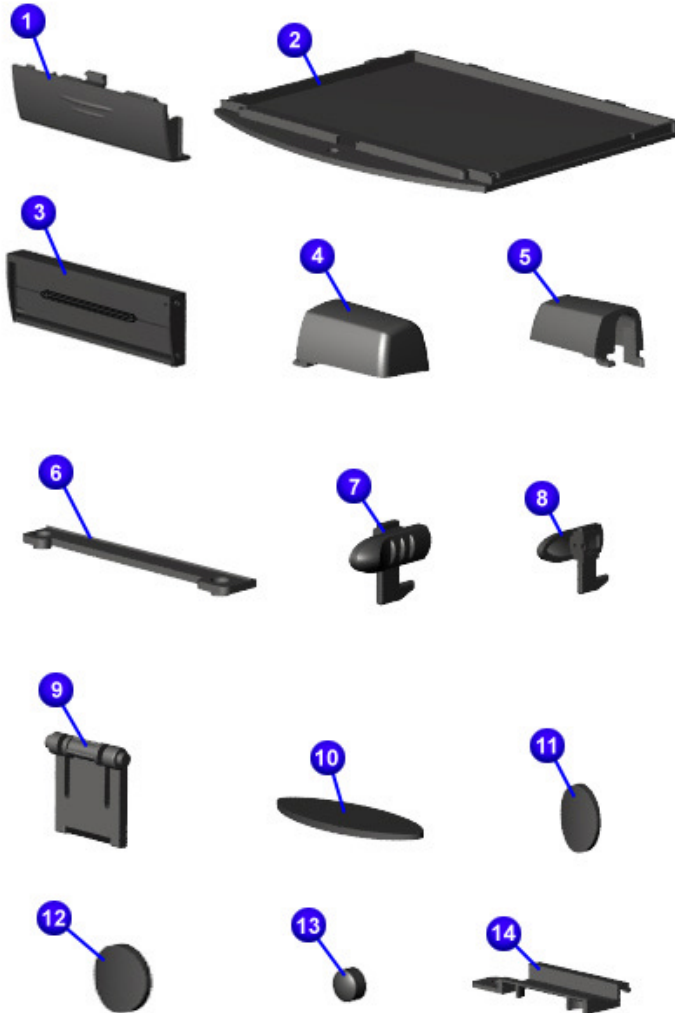

Spare Part Items

Miscellaneous Plastics Kit*

- | | |
|---|---|
| ❶ | Battery Pack Door |
| ❷ | Memory Module Cover |
| ❸ | PC Card (PCMCIA) Door |
| ❹ | Display Hinge Cover (right) |
| ❺ | Display Hinge Cover (left) |
| ❻ | CD Drive Guide |
| ❼ | Display Latch (right) |
| ❽ | Display Latch (left) |
| ❾ | Pop-up foot |
| ❿ | Rubber Logo Plug |
| ⓫ | Rubber Plug (Side Mount for 14.1-in. Display) |
| ⓬ | Rubber Plug (Side Mount for 15.0-in. Display) |
| ⓭ | Rubber Foot |
| ⓮ | Display Mounting Rail |
| ⓯ | (not shown) LCD Cover |

**Kit includes one each of the above unless quantity is stated.*

To order parts, refer to [Part Numbers & Availability](#) later in this chapter.

maintenance & service guide

Presario 1800/1800T Series
Models: XL280, XL380, XL381,
and XL390

Miscellaneous Parts

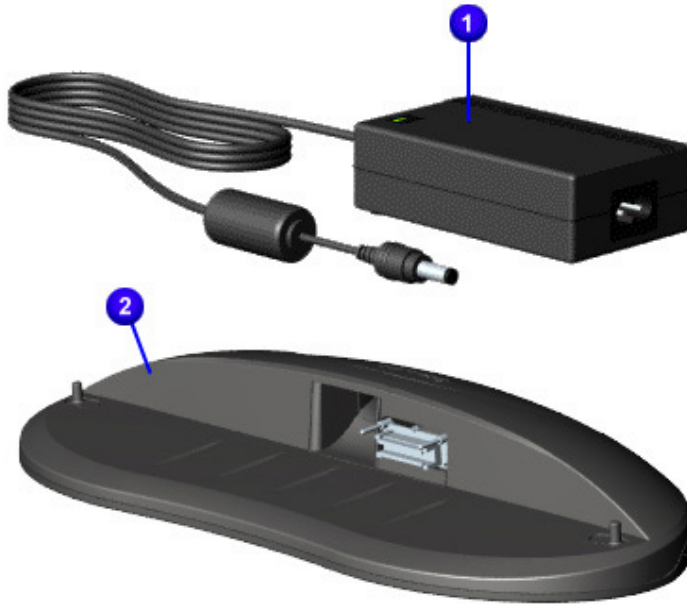

Spare Part Items

- ❶ AC Adapter
(APD, 60 W, or Slim 2 Wire)
- ❷ QuikDock (Port Replicator)
- ❸ *(not shown)*
AC Power Cord
(NA or 3 Wire Intl/UK/IT)
- ❹ *(not shown)*
Miscellaneous Screw Kit
- ❺ *(not shown)* Logo Kit
- ❻ *(not shown)* Return Kit

To order parts, refer to [Part Numbers & Availability](#) later in this chapter.

Documentation & Software

Spare Part Items	
Beyond Setup Guide	Personal Audio Player Card
Compaq Win2K Guide	Quick Restore Kit and CD
Compaq WinME Guide	Quick Restore Recovery CD Kit
Easy Setup Poster	Read-This-First Card: AOL Connection
Emergency Recovery CD Kit	Read-This-First Card: Quick Restore
Microsoft Win2K Professional Manual Kit	Safety and Comfort Guide
Microsoft WinME Manual Kit	SnapFish Assembly Card
Microsoft Word2000 CD Kit	Warranty
Options Catalog	Win2000 Driver CD Kit
Owner Registration Card (Win2000)	

To order documentation or software, refer to [Part Numbers & Availability](#) later in this chapter.

maintenance & service guide

Presario 1800/1800T Series
Models: XL280, XL380, XL381,
and XL390

Part Numbers & Availability

This section is a comprehensive list of the parts associated with the 1800XL Series Notebooks. It provides the part number, applicable model(s), and availability of each item.

Build-to-Order Models

1800 XL280 Model		1800 XL380, XL381, and XL390 Models	
Build-to-Order Items	Part No.	Build-to-Order Items	Part No.
Base	171816-001	Base	171816-001
Processor: Pentium III 650 MHz	175322-001	Processor: Pentium III 700 MHz*	175323-001*
System Board: w/ 64 MB, 100 MHz SD Memory	199192-001	System Board: w/ 64 MB, 100 MHz SD Memory	199192-001
Display: 15-in. TFT/LVDS MD	203698-001	Display: 15-in TFT/LVDS MD	203698-001
Optical Drive: 8X DVD	175326-001	Optical Drive: 8X DVD	175326-001
Hard Drive: 6.0 GB	170087-001	Hard Drive: 20.0 GB**	200350-001**
Battery: 3.2 Ahr Li-ion Enhanced	138184-001	Battery: 3.6 Ahr Li-ion Enhanced	177458-001
Extended Memory: none	n/a	Extended Memory: 64 MB, 100 MHz PC100	122700-001
Operating System: Win98SE	n/a	Operating System: WinME M3	n/a

*Model XL390 has a Pentium III 850 MHz processor (P/N: 200353-001).

**Model XL381 has a 15.0 GB hard drive (P/N: 216173-001).

To find additional parts available for these models, refer to the [Alphabetical Spares Listing](#) later in this chapter.

maintenance & service guide

Presario 1800/1800T Series
Models: XL280, XL380, XL381,
and XL390

Alphabetical Spares Listing

In this section, all spare parts associated with the 1800XL models are listed alphabetically by name.

[A](#) [B](#) [C](#) [D](#) [E](#) [F](#) [G](#) [H](#) [I](#) [J](#) [K](#) [L](#) [M](#) [N](#) [O](#) [P](#) [Q](#) [R](#) [S](#) [T](#) [U](#) [V](#) [W](#) [X](#) [Y](#) [Z](#)

Spare Part Description	Spare P/N	Applicable Models	Availability
AC Adapter (60 W Slim 3 Wire)	180675-001	XL381	
AC Adapter (60 W Slim 2 Wire)	180676-001	All	
AC Power Cord (NA)	293831-001	All	
AC Power Cord (Intl 3 Wire)	170513-002	XL381	
AC Power Cord (UK 3 Wire)	170513-031	XL381	
AC Power Cord (IT 3 Wire)	170513-061	XL381	
Battery Charger Board, See Voltage Converter Board			
Battery Pack (3.2 Ahr, Li-ion Enhanced)	138184-001	XL280	
Battery Pack (3.6 Ahr, Li-ion Enhanced)	177458-001	CTO	after 6/6/00
Beyond Setup Guide	181115-002	All	
Button Board Cover w/Internet Buttons	203699-001	All	
CD-ROM Drive 24X	143922-001	CTO	after 6/6/00
CD-RW Drive	171377-001	CTO	after 6/6/00 until 1/7/01
CD-RW Drive (8X/4X/24X)	200355-001	CTO	after 11/5/00
Compaq Win2K Guide	181247-001	CTO	after 9/3/00
Compaq WinME Guide	181272-001	All	
CPU Cover w/Power Switch	138183-001	XL280, XL380, XL381 and CTO	after 6/6/00
CPU Cover w/Power Switch (1 GHz)	221481-001	XL390	
Diskette Drive (1.44 MB)	138188-001	All	
Display Panel (14.1-in. TFT/LVDS MD)	199194-001	CTO	after 6/6/00
Display Panel (15-in. SXGA, A0031)	219808-001	CTO	
Display Panel (15-in. SXGA MD)	191192-001	XL280 and CTO	after 6/6/00
Display Panel (15-in. TFT/LVDS, A0031)	218311-001	XL380, 381, and 390	
Display Panel (15-in. TFT/LVDS MD)	203698-001	CTO	after 6/6/00



maintenance & service guide

Presario 1800/1800T Series

Models: XL280, XL380, XL381,
and XL390

Spare Part Description	Spare P/N	Applicable Models	Availability
Disqplay Module, See LCD Indicator Module			
DVD/CD-RW Combo Drive	200356-001	CTO	after 11/26/00
DVD Drive (6X W2K)	192408-001	CTO	
DVD Drive (8X)	175326-001	All models and CTO	after 6/6/00
Easy Setup Poster	180720-001	All	
Emergency Recovery CD Kit	157296-003	All	
Enclosure Base	171816-001	XL280, 380, 381, and CTO	after 9/3/00
Enclosure Base (1 GHz)	221480-001	XL390	
Fan Assembly	138162-001	All	
Fan Assembly (1 GHz)	159500-001	XL390	
Hard Drive (6.0 GB)	170087-001	XL280	
Hard Drive (10.0 GB)	200349-001	CTO	after 8/15/00
Hard Drive (15.0 GB)	216173-001	XL381 and CTO	after 8/15/00
Hard Drive (20.0 GB)	200350-001	XL380, XL390 and CTO	after 8/15/00
Hard Drive (32.0 GB 5400 RPM)	200351-001	CTO	after 8/15/00
Heat Sink (Heatspreader)	218312-001	All	
Heat Sink (1 GHz)	221483-001	XL390	
Internet Switch Board (LCD)	138186-001	XL380, XL381, XL390, and CTO	after 6/6/00
Internet Switch Board (SXGA)	199195-001	XL280 and CTO	
Keyboard (US)	171819-001	XL280, XL380, XL390, and CTO	after 6/6/00
Keyboard (UK)	171819-031	XL381	
Keyboard (FR)	171819-051	XL381	
Keyboard (IT)	171819-061	XL381	
LCD Indicator (Disqplay) Module	138187-001	All	
LCD Indicator (Disqplay) Module	177457-001	XL280 and CTO	
Logo Kit	169610-001	All	

Manuals, See [Beyond Setup Guide](#), [Compaq Win2K](#), [Compaq WinME](#), [Microsoft Win2K](#), and [Microsoft WinME](#)



maintenance & service guide

Presario 1800/1800T Series Models: XL280, XL380, XL381, and XL390

Spare Part Description	Spare P/N	Applicable Models	Availability
Memory (32 MB SDRAM, PC100, SO DIMM)	122699-001	CTO	after 6/6/00
Memory (64 MB SDRAM, PC100, SO DIMM)	122700-001	XL380, XL381, XL390, and CTO	after 6/6/00
Memory (128 MB SDRAM, SO DIMM)	123930-001	CTO	after 6/6/00
Memory (256 MB SDRAM, PC100, SO DIMM)	175325-001	CTO	after 6/6/00
Microsoft Win2K Professional Manual Kit	169879-001	CTO	after 9/3/00
Microsoft WinME Manual Kit	180309-001	All	
Microsoft Word2000 CD Kit	147234-001	All US platforms	
Miscellaneous Cable Kit	138189-001	All	
Miscellaneous Hardware Kit	138160-001	All	
Miscellaneous Plastics Kit	138190-001	All	
Miscellaneous Screw Kit	138161-001	All	
Modem K-56K Data/Fax w/o SRAM	400445-001	All	
Mouse (USB)		CTO	after 8/15/00
Options Catalog	166299-003	All US platforms	
Owner Registration Card (Win2000)	141572-005	CTO	after 9/3/00
Palmrest Cover w/ TouchPad Button Bd	138181-001	All	
Personal Audio Player Card	216792-001	All US platforms	
Port Replicator, See QuikDock			
Processor (600 MHz Celeron)	201347-001	CTO	after 9/1/00
Processor (600 MHz PIII 256K)	175319-001	CTO	after 6/6/00
Processor (650 MHz PIII 256K)	175322-001	XL280 and CTO	after 6/6/00 until 9/15/00
Processor (700 MHz PIII 256K)	175323-001	XL380, XL381, and CTO	after 6/6/00
Processor (750 MHz PIII 256K)	199193-001	CTO	after 6/19/00
Processor (800 MHz PIII)	200352-001	CTO	after 9/25/00
Processor (850 MHz PIII)	200353-001	XL390 and CTO	after 9/25/00
Quick Restore CD (Win2000)	219813-001	CTO	after 9/3/00
Quick Restore Kit (Win2000)	219812-001	CTO	after 9/3/00

maintenance & service guide

Presario 1800/1800T Series

Models: XL280, XL380, XL381,
and XL390

Spare Part Description	Spare P/N	Applicable Models	Availability
Quick Restore Recovery CD Kit	157296-003	All	
QuikDock (Port Replicator)	138167-001	All	
Read-This-First Card: AOL Connection	221569-001	All US platforms	
Read-This-First Card: Quick Restore (Win2000)	176779-001	CTO	after 9/3/00
Return Kit	138166-001	All	
Safety and Comfort Guide	191432-001	All	
SnapFish Assembly Card	216035-002 (alt -001)	All US platforms	
Speakers, Enclosure, and Cables	138185-001	All	
System I/O Board (w/ 64 MB SDRAM)	199192-001	XL280 and CTO	
System I/O Board (w/ 64 MB SDRAM, 8 MB M3 VRAM)	217803-001	XL380, XL381, XL390, CTO	
System I/O Board (w/ 64 MB SDRAM, 16 MB M3 VRAM)	217804-001	CTO	
Voltage Converter Board (Battery Charger)	171815-001	All	
Warranty Statement	170835-004	All US platforms	
Win2000 Driver CD Kit	191298-003	CTO	after 9/3/00

To see illustrations of each part and a list of items contained in each miscellaneous parts kit, refer to [Illustrated Parts](#) earlier in this chapter.

Free Manuals Download Website

<http://myh66.com>

<http://usermanuals.us>

<http://www.somanuals.com>

<http://www.4manuals.cc>

<http://www.manual-lib.com>

<http://www.404manual.com>

<http://www.luxmanual.com>

<http://aubethermostatmanual.com>

Golf course search by state

<http://golfingnear.com>

Email search by domain

<http://emailbydomain.com>

Auto manuals search

<http://auto.somanuals.com>

TV manuals search

<http://tv.somanuals.com>