

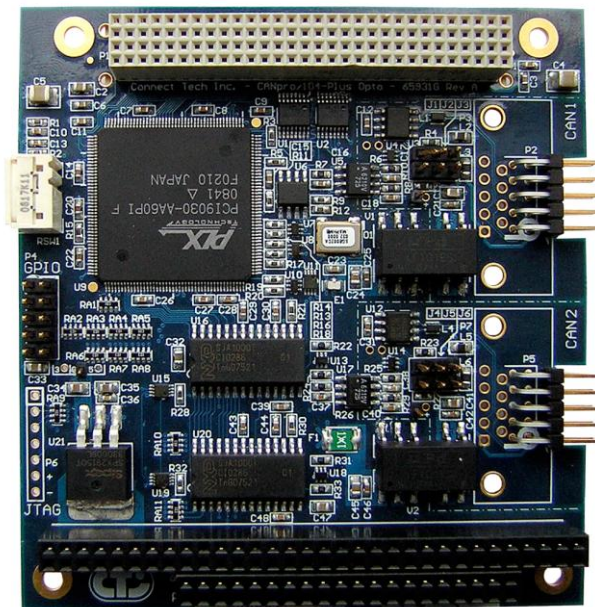

Connect Tech Inc.
Industrial Strength Communications

USER MANUAL

CANpro/104-Plus Opto



CTIM-00052 Revision 0.00 - April 23, 2009

Copyright Notice

The information contained in this document is subject to change without notice. Connect Tech Inc. shall not be liable for errors contained herein or for incidental consequential damages in connection with the furnishing, performance, or use of this material. This document contains proprietary information that is protected by copyright. All rights are reserved. No part of this document may be photocopied, reproduced, or translated to another language without the prior written consent of Connect Tech, Inc.

Copyright © 2009 by Connect Tech Inc.

Trademark Acknowledgement

Connect Tech Inc. acknowledges all trademarks, registered trademarks and/or copyrights referred to in this document as the property of their respective owners.

Not listing all possible trademarks or copyright acknowledgments does not constitute a lack of acknowledgment to the rightful owners of the trademarks and copyrights mentioned in this document.

Revision History

Revision 0.00	April 23, 2009 Original Document
----------------------	--

Table of Contents

Copyright Notice	2
Trademark Acknowledgement.....	2
Revision History	2
Table of Contents.....	3
Introduction.....	4
Features.....	4
CANpro/104-Plus Opto Diagrams.....	5
Hardware Installation.....	7
PCI Interrupt, Clock and ID Selection	8
On-Board Jumper Configuration.....	9
120 Ohm Termination Jumpers	9
Slew Rate Control Jumpers	10
DB-9 Frame Ground Connect	10
Connector Pinouts.....	11
Software Configuration.....	12
GPIO Details.....	18
GPIO Header.....	18
GPIO Control and Addressing	19
Specifications.....	20
Operating Environment	20
Power Requirements	20
PC Bus Interface.....	20
Optical/Power Isolation.....	20
Dimensions.....	20
Connectors/Interface	20
GPIO	20
Certification	21
Certification for CANpro/104-Plus Opto.....	21
Limited Lifetime Warranty	22
Customer Support Overview.....	22
Contact Information	22

Introduction

CANpro/104-Plus Opto combines the power of two independent NXP SJA1000 CAN controllers with 3kV optical isolation to provide maximum protection for industrial control applications exposed to harsh conditions. Based on the PCI bus and a PCI-104 form factor, CANpro/104-Plus Opto frees up valuable I/O space for greater flexibility in your embedded system.

Features

- Two independent, industry standard NXP SJA1000 CAN controllers (2.0B compliant)
- PCI-104 2.2 compliant
- 16MHz SJA1000 input clock
- 32MHz local bus clock
- Fail-safe power-up/power-down using on-board impedance transceivers to maximize nodes on the bus and ensure glitch-free operation.
- Supports up to 1.0 Mbps operation and over 120 nodes on the bus
- 3kV optical isolation for each port from the host system
- Output slew rate limiting for lower radiated emissions
- Memory mapped addressing to save valuable I/O space (no jumpers required)
- Decoded address range is configurable for BasicCAN and PeliCAN modes
- Two ten pin right angled headers as standard I/O connectors (DB-9 option available)
- GPIO: 8-bit 3.3V I/O header
- Operating temperature range of -40°C to 85°C
- +5V DC 500mA (max.) power output
- RoHS compliant

CANpro/104-Plus Opto Diagrams

Figure 1 illustrates the location of each component on the CANpro/104-Plus Opto.

Figure 1: CANpro/104-Plus Opto Block Diagram

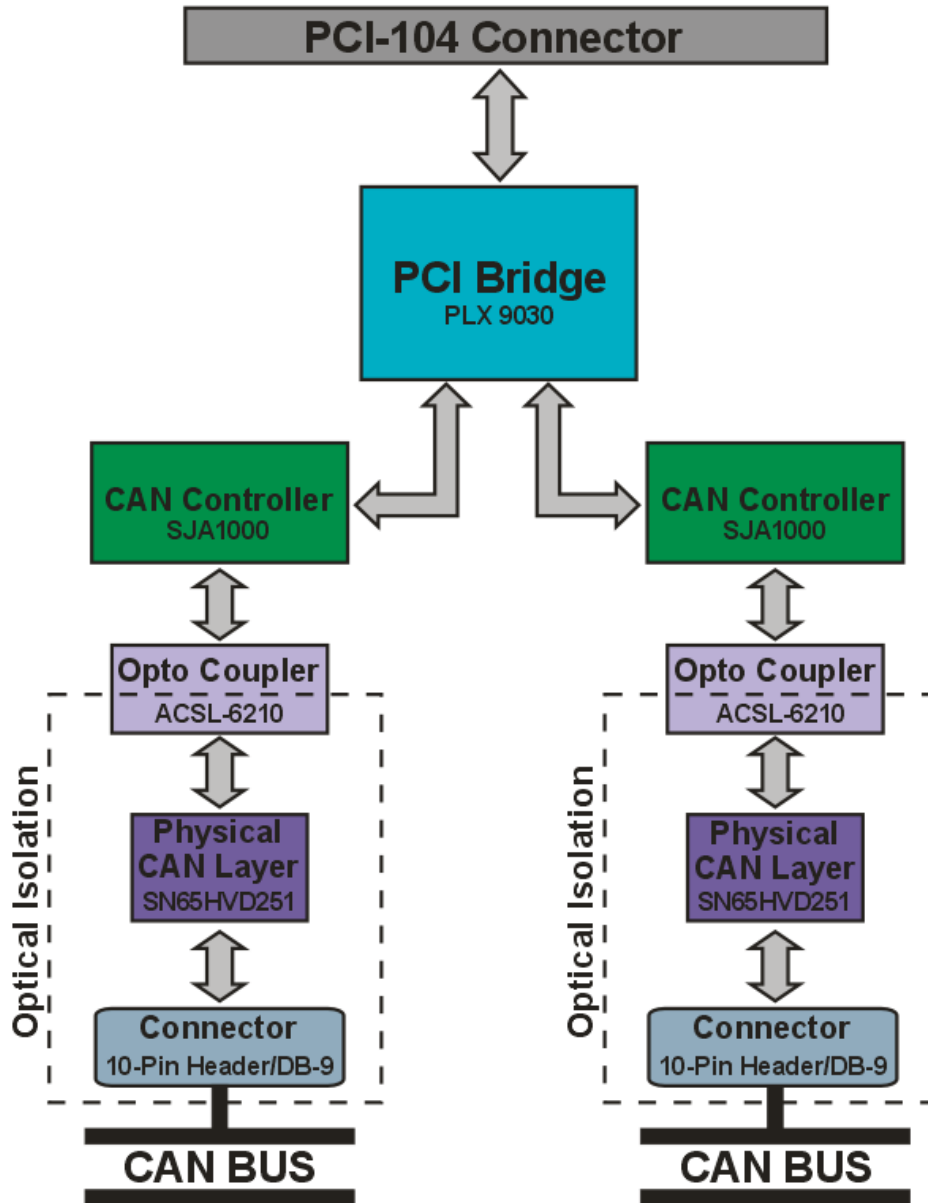
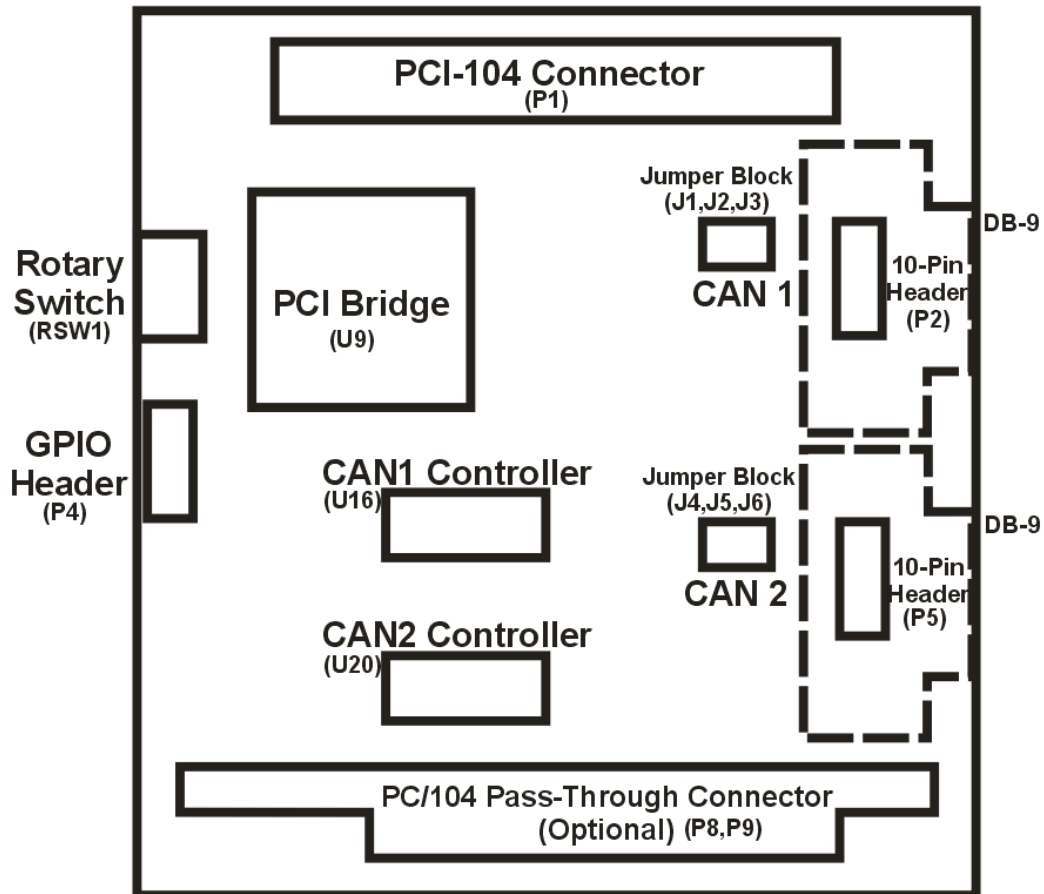

Figure 2: CANpro/104-Plus Opto Board Diagram



Hardware Installation

Before You Begin

Before you begin, take a minute to ensure that your package includes the required components that should have shipped with your CANpro/104-Plus Opto.

- One CANpro/104-Plus Opto CAN controller board
- One CD containing documentation

If anything is missing, contact [Connect Tech](#) or your reseller. Also, visit the [Download Zone](#) of the [Support Center](#) on the Connect Tech website for the latest product manuals, installation guides, diagnostic utilities and device driver software.

Installing the CANpro/104-Plus Opto Into Your System

- Turn off the power to your embedded computer and open any enclosures needed to access the PC/104-Plus or PCI-104 expansion connectors.
- Carefully insert the board into the PC/104-Plus or PCI-104 connector.
- Set the ID rotary switch accordingly (see [Table 1](#)).
- Set the correct on-board jumpers for each CAN port (J1 – J6) (see pages 9-10 for more details).
- Power on your embedded computer and install the appropriate drivers for your operating system.

PCI Interrupt, Clock and ID Selection

The following PCI signals, (INTA#, INTB# INTC# INTD#), (CLK0, CLK1, CLK2, CLK3), (IDSEL0, IDSEL1, IDSEL2, IDSEL3), are selected by using the Rotary Switch on the CANpro/104-Plus Opto board (RSW1). Selections need to match the stack location of the CANpro/104-Plus Opto in your PC/104-Plus stack. See [Table 1](#) below for more details.

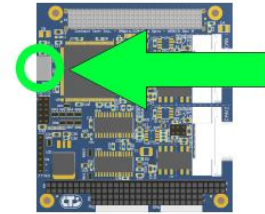

Rotary Switch Location

Table 1: Rotary Selection

Stack Location	Rotary Setting	PCI INT#	PCI CLK	PCI IDSEL	
ADD-ON #4 ADD-ON #3 ADD-ON #2 ADD-ON #1 CPU / MASTER		0 or 4	INTA#	CLK0	IDSEL0
ADD-ON #4 ADD-ON #3 ADD-ON #2 ADD-ON #1 CPU / MASTER		1 or 5	INTB#	CLK1	IDSEL1
ADD-ON #4 ADD-ON #3 ADD-ON #2 ADD-ON #1 CPU / MASTER		2 or 6	INTC#	CLK2	IDSEL2
ADD-ON #4 ADD-ON #3 ADD-ON #2 ADD-ON #1 CPU / MASTER		3 or 7	INTD#	CLK3	IDSEL3

Please visit http://www.pc104.org/pc104_plus_specs.php to request the full PC/104-Plus specification for more details on signals.

On-Board Jumper Configuration

Figure 3: CAN Ports and Jumper Locations

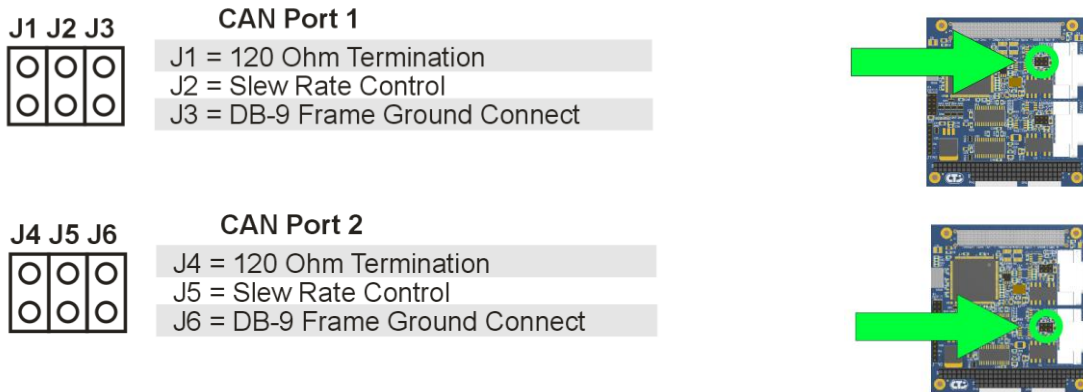

120 Ohm Termination Jumpers

Jumpers J1 and J4 will enable a 120 Ohm termination resistor across the CAN-H and CAN-L lines. Termination is always recommended for improved signal integrity, especially for long transmission lines. Termination requirements should be evaluated on a case by case basis. Typically both ends of a CAN bus are terminated, but termination is not enabled on cards that sit in the middle of the bus. See [Figure 4](#) and [Figure 5](#) for examples that indicate when to use this jumper selection.

Figure 4: Example – CANpro/104-Plus Opto at the end of a CAN bus

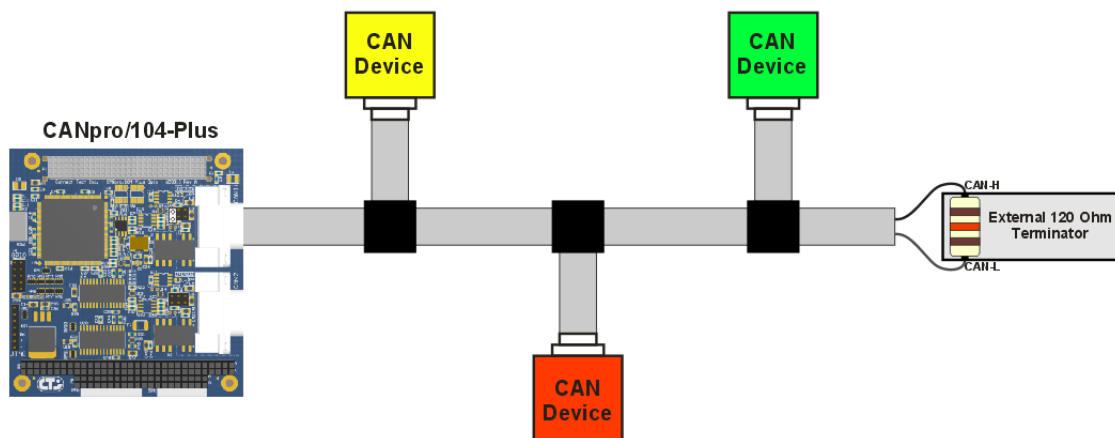

NOTE:

The 120 Ohm termination jumper **must** be installed in this situation.

Figure 5: Example CANpro/104-Plus Opto in the middle of the CAN bus

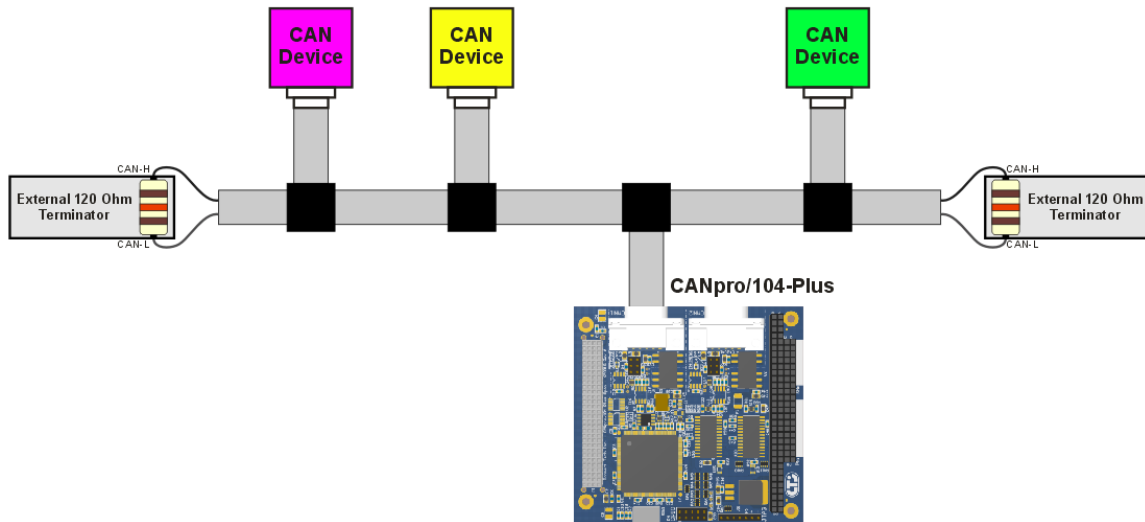

NOTE:

The 120 Ohm termination jumper **does not** need to be installed in this situation.

Slew Rate Control Jumpers

Installing a jumper on J2 or J5 (see [Figure 3](#)) will disable slew rate limiting for the associated CAN port. Slew rate limiting will reduce the emitted switching noise that is sent out onto the CAN bus lines and radiated from those lines. Switching noise may cause EMI/EMC incompatibilities depending on the cabling used to support the system. The use of slew rate limiting may aid in a system that is nearing the maximum limit of emissions. Properly shielded cabling will also dramatically reduce emissions. Slew rate limiting may only be used on busses operating at slower baud rates. With the jumper installed, full 1Mbps operation is possible.

DB-9 Frame Ground Connect

CANpro/104-Plus Opto models that have DB-9 connectors, will allow you optionally enable the Frame Ground to be tied to ports isolated ground plane with J3 and J6.

Connector Pinouts

Table 2: DB-9 Cable Connector Pinouts

Pin No.	Signal
1	+5V
2	CAN-L
3	CAN GND (isolated or non)
4	N/C
5	N/C
6	CAN GND (isolated or non)
7	CAN-H
8	N/C
9	+5V

Male DB-9 Connector

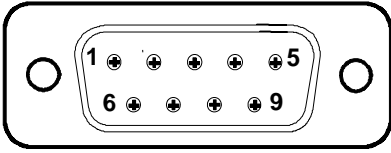

The diagram shows a rectangular connector with two circular mounting holes on the left and right sides. Inside the rectangle, there are two rows of five pins each. The top row pins are numbered 1, 2, 3, 4, and 5 from left to right. The bottom row pins are numbered 6, 7, 8, and 9 from left to right. Pin 9 is the rightmost pin in the bottom row.

Boards that are populated with right angled 2x5 0.100" headers will include a cable (CAG104) that will break out from the on-board 2x5 header to a DB-9 connector.

Table 3: 10-pin Header Pinouts

Pin No.	Signal
1	+5V
2	CAN-GND (isolated or non)
3	CAN-L
4	CANH
5	CAN-GND (isolated or non)
6	NC
7	NC
8	+5V
9	NC
10	NC

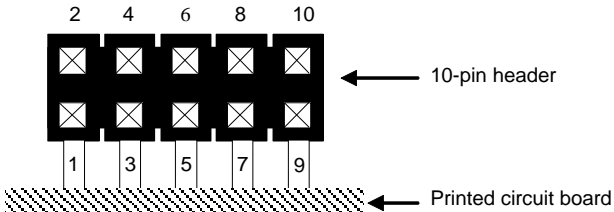

The diagram shows a 10-pin header with two rows of five pins. The top row pins are numbered 2, 4, 6, 8, and 10 from left to right. The bottom row pins are numbered 1, 3, 5, 7, and 9 from left to right. An arrow points to the header with the label "10-pin header". Below the header, a hatched area represents the "Printed circuit board" with an arrow pointing to it.

Software Configuration

The information provided below is intended for advanced users and developers that wish to create their own custom drivers. Typical CANpro/104-Plus Opto users will use the driver provided by Connect Tech.

PCI Properties of CANpro/104-Plus Opto

The CANpro/104-Plus Opto card will appear in your system with the following PCI information:

Vender ID: 0x10b5
Device ID: 0x9030
SubVender ID: 0x12c4
SubVender Device ID: 0x900

CAN Controller Address Space

CAN controllers are mapped on the PLX 9030 PCI Base Address 2 (BAR2) to Local Address Space 0. This address space is re-mapped to a local offset of 0x00. Each CAN controller is allotted 256 bytes of address space. CAN controller #1 has a local address range of 0x000 - 0x0FF, while CAN controller #2 has a local address range 0x100 - 0x1FF. See below for the full address/register allocation details in both BasicCAN and PeliCAN modes.

Table 4: CAN Controller #1 (BasicCAN)

	OPERATING MODE		RESET MODE	
	READ	WRITE	READ	WRITE
0x000	CR	CR	CR	CR
0x001		CMR		CMR
0x002	SR		SR	
0x003	IR		IR	
0x004			AC	AC
0x005			AM	AM
0x006			BTR0	BTR0
0x007			BTR1	BTR1
0x008			OC	OC
0x009	TEST	TEST	TEST	TEST
0x00A	TX Buffer Identifier Byte 1	TX Buffer Identifier Byte 1		
0x00B	TX Buffer Identifier Byte 2	TX Buffer Identifier Byte 1		
0x00C	TX Buffer Data Byte 1	TX Buffer Data Byte 1		
0x00D	TX Buffer Data Byte 2	TX Buffer Data Byte 2		
0x00E	TX Buffer Data Byte 3	TX Buffer Data Byte 3		
0x00F	TX Buffer Data Byte 4	TX Buffer Data Byte 4		
0x010	TX Buffer Data Byte 5	TX Buffer Data Byte 5		
0x011	TX Buffer Data Byte 6	TX Buffer Data Byte 6		
0x012	TX Buffer Data Byte 7	TX Buffer Data Byte 7		
0x013	TX Buffer Data Byte 8	TX Buffer Data Byte 8		
0x014	RX Buffer Identifier Byte 1	RX Buffer Identifier Byte 1	RX Buffer Identifier Byte 1	RX Buffer Identifier Byte 1
0x015	RX Buffer Identifier Byte 2	RX Buffer Identifier Byte 2	RX Buffer Identifier Byte 2	RX Buffer Identifier Byte 2
0x016	RX Buffer Data Byte 1	RX Buffer Data Byte 1	RX Buffer Data Byte 1	RX Buffer Data Byte 1
0x017	RX Buffer Data Byte 2	RX Buffer Data Byte 2	RX Buffer Data Byte 2	RX Buffer Data Byte 2
0x018	RX Buffer Data Byte 3	RX Buffer Data Byte 3	RX Buffer Data Byte 3	RX Buffer Data Byte 3
0x019	RX Buffer Data Byte 4	RX Buffer Data Byte 4	RX Buffer Data Byte 4	RX Buffer Data Byte 4
0x01A	RX Buffer Data Byte 5	RX Buffer Data Byte 5	RX Buffer Data Byte 5	RX Buffer Data Byte 5
0x01B	RX Buffer Data Byte 6	RX Buffer Data Byte 6	RX Buffer Data Byte 6	RX Buffer Data Byte 6
0x01C	RX Buffer Data Byte 7	RX Buffer Data Byte 7	RX Buffer Data Byte 7	RX Buffer Data Byte 7
0x01D	RX Buffer Data Byte 8	RX Buffer Data Byte 8	RX Buffer Data Byte 8	RX Buffer Data Byte 8
0x01E				
0x01F	CDR	CDR	CDR	CDR
...				
0x0FF				

Table 5: CAN Controller #2 (BasicCAN)

	OPERATING MODE		RESET MODE	
	READ	WRITE	READ	WRITE
0x100	CR	CR	CR	CR
0x101		CMR		CMR
0x102	SR		SR	
0x103	IR		IR	
0x104			AC	AC
0x105			AM	AM
0x106			BTR0	BTR0
0x107			BTR1	BTR1
0x108			OC	OC
0x109	TEST	TEST	TEST	TEST
0x10A	TX Buffer Identifier Byte 1	TX Buffer Identifier Byte 1		
0x10B	TX Buffer Identifier Byte 2	TX Buffer Identifier Byte 1		
0x10C	TX Buffer Data Byte 1	TX Buffer Data Byte 1		
0x10D	TX Buffer Data Byte 2	TX Buffer Data Byte 2		
0x10E	TX Buffer Data Byte 3	TX Buffer Data Byte 3		
0x10F	TX Buffer Data Byte 4	TX Buffer Data Byte 4		
0x110	TX Buffer Data Byte 5	TX Buffer Data Byte 5		
0x111	TX Buffer Data Byte 6	TX Buffer Data Byte 6		
0x112	TX Buffer Data Byte 7	TX Buffer Data Byte 7		
0x113	TX Buffer Data Byte 8	TX Buffer Data Byte 8		
0x114	RX Buffer Identifier Byte 1	RX Buffer Identifier Byte 1	RX Buffer Identifier Byte 1	RX Buffer Identifier Byte 1
0x115	RX Buffer Identifier Byte 2	RX Buffer Identifier Byte 2	RX Buffer Identifier Byte 2	RX Buffer Identifier Byte 2
0x116	RX Buffer Data Byte 1	RX Buffer Data Byte 1	RX Buffer Data Byte 1	RX Buffer Data Byte 1
0x117	RX Buffer Data Byte 2	RX Buffer Data Byte 2	RX Buffer Data Byte 2	RX Buffer Data Byte 2
0x118	RX Buffer Data Byte 3	RX Buffer Data Byte 3	RX Buffer Data Byte 3	RX Buffer Data Byte 3
0x119	RX Buffer Data Byte 4	RX Buffer Data Byte 4	RX Buffer Data Byte 4	RX Buffer Data Byte 4
0x11A	RX Buffer Data Byte 5	RX Buffer Data Byte 5	RX Buffer Data Byte 5	RX Buffer Data Byte 5
0x11B	RX Buffer Data Byte 6	RX Buffer Data Byte 6	RX Buffer Data Byte 6	RX Buffer Data Byte 6
0x11C	RX Buffer Data Byte 7	RX Buffer Data Byte 7	RX Buffer Data Byte 7	RX Buffer Data Byte 7
0x11D	RX Buffer Data Byte 8	RX Buffer Data Byte 8	RX Buffer Data Byte 8	RX Buffer Data Byte 8
0x11E				
0x11F	CDR	CDR	CDR	CDR
...				
0x1FF				

Table 6: CAN Controller #1 (PeliCAN)

Local Address	OPERATING MODE				RESET MODE	
	READ		WRITE		READ	WRITE
0x000	MOD		MOD		MOD	MOD
0x001			CMR			CMR
0x002	SR				SR	
0x003	IR				IR	
0x004	IER		IER		IER	IER
0x005					AM	AM
0x006	BTR0				BTR0	BTR0
0x007	BTR1				BTR1	BTR1
0x008	OC				OC	OC
0x009	TEST		TEST		TEST	TEST
0x00A						
0x00B	ALC				ALC	
0x00C	ECC				ECC	
0x00D	EWLR				EWLR	EWLR
0x00E	RXERR				RXERR	RXERR
0x00F	TXERR				TXERR	TXERR
0x010	RX Frame Info - SFF	RX Frame Info - EFF	TX Frame Info - SFF	TX Frame Info - EFF	ACR0	
0x011	RX Buffer Identifier Byte 1	RX Buffer Identifier Byte 1	TX Buffer Identifier Byte 1	TX Buffer Identifier Byte 1	ACR1	ACR1
0x012	RX Buffer Identifier Byte 2	RX Buffer Identifier Byte 2	TX Buffer Identifier Byte 2	TX Buffer Identifier Byte 2	ACR2	ACR2
0x013	RX Buffer Data Byte 1	RX Buffer Identifier Byte 3	TX Buffer Data Byte 1	TX Buffer Identifier Byte 3	ACR3	ACR3
0x014	RX Buffer Data Byte 2	RX Buffer Identifier Byte 4	TX Buffer Data Byte 2	TX Buffer Identifier Byte 4	AMR0	AMR0
0x015	RX Buffer Data Byte 3	RX Buffer Data Byte 1	TX Buffer Data Byte 3	TX Buffer Data Byte 1	AMR1	AMR1
0x016	RX Buffer Data Byte 4	RX Buffer Data Byte 2	TX Buffer Data Byte 4	TX Buffer Data Byte 2	AMR2	AMR2
0x017	RX Buffer Data Byte 5	RX Buffer Data Byte 3	TX Buffer Data Byte 5	TX Buffer Data Byte 3	AMR3	AMR3
0x018	RX Buffer Data Byte 6	RX Buffer Data Byte 4	TX Buffer Data Byte 6	TX Buffer Data Byte 4		
0x019	RX Buffer Data Byte 7	RX Buffer Data Byte 5	TX Buffer Data Byte 7	TX Buffer Data Byte 5		
0x01A	RX Buffer Data Byte 8	RX Buffer Data Byte 6	TX Buffer Data Byte 8	TX Buffer Data Byte 6		
0x01B		RX Buffer Data Byte 7		TX Buffer Data Byte 7		
0x01C		RX Buffer Data Byte 8		TX Buffer Data Byte 8		
0x01D	RX Message Counter				RX Message Counter	
0x01E	RX Buffer Start Address				RX Buffer Start Address	RX Buffer Start Address
0x01F	CDR		CDR		CDR	CDR
0x020	Internal RAM Address 0				Internal RAM Address 0	Internal RAM Address 0
0x021	Internal RAM Address 1				Internal RAM Address 1	Internal RAM Address 1
0x022	Internal RAM Address 2				Internal RAM Address 2	Internal RAM Address 2
0x023	Internal RAM Address 3				Internal RAM Address 3	Internal RAM Address 3
...
0x06D	Internal RAM Address 77				Internal RAM Address 77	Internal RAM Address 77
0x06E	Internal RAM Address 78				Internal RAM Address 78	Internal RAM Address 78
0x06F	Internal RAM Address 79				Internal RAM Address 79	Internal RAM Address 79
0x070						
0x071						
...
0x0FF						

Table 7: CAN Controller #2 (PeliCAN)

Local Address	OPERATING MODE				RESET MODE	
	READ		WRITE		READ	WRITE
0x100	MOD		MOD		MOD	MOD
0x101			CMR			CMR
0x102	SR				SR	
0x103	IR				IR	
0x104	IER		IER		IER	IER
0x105					AM	AM
0x106	BTR0				BTR0	BTR0
0x107	BTR1				BTR1	BTR1
0x108	OC				OC	OC
0x109	TEST		TEST		TEST	TEST
0x10A						
0x10B	ALC				ALC	
0x10C	ECC				ECC	
0x10D	EWLR				EWLR	EWLR
0x10E	RXERR				RXERR	RXERR
0x10F	TXERR				TXERR	TXERR
0x110	RX Frame Info - SFF	RX Frame Info - EFF	TX Frame Info - SFF	TX Frame Info - EFF	ACR0	
0x111	RX Buffer Identifier Byte 1	RX Buffer Identifier Byte 1	TX Buffer Identifier Byte 1	TX Buffer Identifier Byte 1	ACR1	ACR1
0x112	RX Buffer Identifier Byte 2	RX Buffer Identifier Byte 2	TX Buffer Identifier Byte 2	TX Buffer Identifier Byte 2	ACR2	ACR2
0x113	RX Buffer Data Byte 1	RX Buffer Identifier Byte 3	TX Buffer Data Byte 1	TX Buffer Identifier Byte 3	ACR3	ACR3
0x114	RX Buffer Data Byte 2	RX Buffer Identifier Byte 4	TX Buffer Data Byte 2	TX Buffer Identifier Byte 4	AMR0	AMR0
0x115	RX Buffer Data Byte 3	RX Buffer Data Byte 1	TX Buffer Data Byte 3	TX Buffer Data Byte 1	AMR1	AMR1
0x116	RX Buffer Data Byte 4	RX Buffer Data Byte 2	TX Buffer Data Byte 4	TX Buffer Data Byte 2	AMR2	AMR2
0x117	RX Buffer Data Byte 5	RX Buffer Data Byte 3	TX Buffer Data Byte 5	TX Buffer Data Byte 3	AMR3	AMR3
0x118	RX Buffer Data Byte 6	RX Buffer Data Byte 4	TX Buffer Data Byte 6	TX Buffer Data Byte 4		
0x119	RX Buffer Data Byte 7	RX Buffer Data Byte 5	TX Buffer Data Byte 7	TX Buffer Data Byte 5		
0x11A	RX Buffer Data Byte 8	RX Buffer Data Byte 6	TX Buffer Data Byte 8	TX Buffer Data Byte 6		
0x11B		RX Buffer Data Byte 7		TX Buffer Data Byte 7		
0x11C		RX Buffer Data Byte 8		TX Buffer Data Byte 8		
0x11D	RX Message Counter				RX Message Counter	
0x11E	RX Buffer Start Address				RX Buffer Start Address	RX Buffer Start Address
0x11F	CDR				CDR	CDR
0x120	Internal RAM Address 0				Internal RAM Address 0	Internal RAM Address 0
0x121	Internal RAM Address 1				Internal RAM Address 1	Internal RAM Address 1
0x122	Internal RAM Address 2				Internal RAM Address 2	Internal RAM Address 2
0x123	Internal RAM Address 3				Internal RAM Address 3	Internal RAM Address 3
...
0x16D	Internal RAM Address 77				Internal RAM Address 77	Internal RAM Address 77
0x16E	Internal RAM Address 78				Internal RAM Address 78	Internal RAM Address 78
0x16F	Internal RAM Address 79				Internal RAM Address 79	Internal RAM Address 79
0x170						
0x171						
...
0x1FF						

CAN Controller Interrupts

Each CAN controller is tied to a local interrupt on the PLX9030 which is then forwarded to a single interrupt on the PCI bus. Access to the PLX9030 interrupt control/status register can be done by accessing the INTCSR register at offset 4Ch from the PCI base address of the CANpro/104-Plus Opto.

Register 10-57. (INTCSR; 4Ch) Interrupt Control/Status

Bit	Description	Read	Write	Value after Reset
0	LINTi1 Enable. Value of 1 indicates enabled. Value of 0 indicates disabled.	Yes	Yes	0
1	LINTi1 Polarity. Value of 1 indicates active high. Value of 0 indicates active low.	Yes	Yes	0
2	LINTi1 Status. Value of 1 indicates interrupt active. Value of 0 indicates interrupt not active.	Yes	No	0
3	LINTi2 Enable. Value of 1 indicates enabled. Value of 0 indicates disabled.	Yes	Yes	0
4	LINTi2 Polarity. Value of 1 indicates active high. Value of 0 indicates active low.	Yes	Yes	0
5	LINTi2 Status. Value of 1 indicates interrupt active. Value of 0 indicates interrupt not active.	Yes	No	0
6	PCI Interrupt Enable. Value of 1 enables PCI interrupt.	Yes	Yes	0
7	Software Interrupt. Value of 1 generates PCI interrupt (INTA# output asserted) if the PCI Interrupt Enable bit is set (bit [6]=1).	Yes	Yes	0
8	LINTi1 Select Enable. Value of 1 indicates enabled edge triggerable interrupt. Value of 0 indicates enabled level triggerable interrupt. <i>Note: Operates only in High-Polarity mode (bit [1]=1).</i>	Yes	Yes	0
9	LINTi2 Select Enable. Value of 1 indicates enabled edge triggerable interrupt. Value of 0 indicates enabled level triggerable interrupt. <i>Note: Operates only in High-Polarity mode (bit [4]=1).</i>	Yes	Yes	0
10	Local Edge Triggerable Interrupt Clear. Writing 1 to this bit clears LINTi1.	Yes	Yes	0
11	Local Edge Triggerable Interrupt Clear. Writing 1 to this bit clears LINTi2.	Yes	Yes	0
15:12	Reserved.	Yes	No	0h

This diagram is taken from the PLX9030 Data Book v1.4.

GPIO Details

GPIO Header

CANpro/104-Plus Opto includes a 10-pin header with 8-bits of 3.3V General Purpose IO. The location and description of this header can be found below.

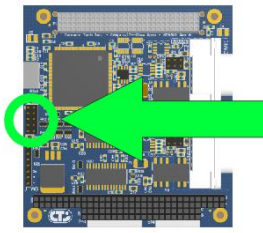
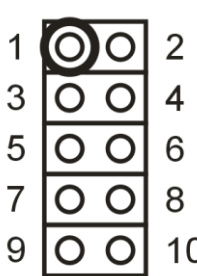
Header Location	Pin Locations	Signal Descriptions																						
	<p>GPIO</p> 	<table border="1"> <thead> <tr> <th>Pin Number</th> <th>Signal</th> </tr> </thead> <tbody> <tr><td>1</td><td>GPIO BIT 0</td></tr> <tr><td>2</td><td>GPIO BIT 1</td></tr> <tr><td>3</td><td>GPIO BIT 2</td></tr> <tr><td>4</td><td>GPIO BIT 3</td></tr> <tr><td>5</td><td>GPIO BIT 4</td></tr> <tr><td>6</td><td>GPIO BIT 5</td></tr> <tr><td>7</td><td>GPIO BIT 6</td></tr> <tr><td>8</td><td>GPIO BIT 7</td></tr> <tr><td>9</td><td>+3.3V</td></tr> <tr><td>10</td><td>GND</td></tr> </tbody> </table>	Pin Number	Signal	1	GPIO BIT 0	2	GPIO BIT 1	3	GPIO BIT 2	4	GPIO BIT 3	5	GPIO BIT 4	6	GPIO BIT 5	7	GPIO BIT 6	8	GPIO BIT 7	9	+3.3V	10	GND
Pin Number	Signal																							
1	GPIO BIT 0																							
2	GPIO BIT 1																							
3	GPIO BIT 2																							
4	GPIO BIT 3																							
5	GPIO BIT 4																							
6	GPIO BIT 5																							
7	GPIO BIT 6																							
8	GPIO BIT 7																							
9	+3.3V																							
10	GND																							

GPIO Control and Addressing

GPIO pins on the CANpro/104-Plus Opto are controlled via the GPIOC register within the PLX 9030. The register is located at offset 0x54 from the PLX9030 PCI Base Address. The CANpro/104-Plus Opto ships with all GPIO pins set up as a data output pin by default.

Bit	Description	Read	Write	Value after Reset
0	GPIO0 or WAITo# Pin Select. Selects the function of GPIO0/WAITo# pin. Value of 1 indicates pin is WAITo#. Value of 0 indicates pin is GPIO0.	Yes	Yes	0
1	GPIO0 Direction. Value of 0 indicates Input. Value of 1 indicates output. Always an output if WAITo# function is selected.	Yes	Yes	0
2	GPIO0 Data. If programmed as output, writing 1 causes corresponding pin to go high. If programmed as input, reading provides state of corresponding pin.	Yes	Yes	0
3	GPIO1 or LLOCKo# Pin Select. Selects the function of GPIO1/LLOCKo# pin. Value of 1 indicates pin is LLOCKo#. Value of 0 indicates pin is GPIO1.	Yes	Yes	0
4	GPIO1 Direction. Value of 0 indicates Input. Value of 1 indicates output. Always an output if LLOCK function is selected.	Yes	Yes	0
5	GPIO1 Data. If programmed as output, writing 1 causes corresponding pin to go high. If programmed as input, reading provides state of corresponding pin.	Yes	Yes	0
6	GPIO2 or CS2# Pin Select. Selects the function of GPIO2/CS2# pin. Value of 1 indicates pin is CS2#. Value of 0 indicates pin is GPIO2.	Yes	Yes	0
7	GPIO2 Direction. Value of 0 indicates Input. Value of 1 indicates output. Always an output if CS2# function is selected.	Yes	Yes	0
8	GPIO2 Data. If programmed as output, writing 1 causes corresponding pin to go high. If programmed as input, reading provides state of corresponding pin.	Yes	Yes	0
9	GPIO3 or CS3# Pin Select. Selects the function of GPIO3/CS3# pin. Value of 1 indicates pin is CS3#. Value of 0 indicates pin is GPIO3.	Yes	Yes	0
10	GPIO3 Direction. Value of 0 indicates Input. Value of 1 indicates output. Always an output if CS3# function is selected.	Yes	Yes	0
11	GPIO3 Data. If programmed as output, writing 1 causes corresponding pin to go high. If programmed as input, reading provides state of corresponding pin.	Yes	Yes	0
12	GPIO4 or LA27 Pin Select. Selects the function of GPIO4/LA27 pin. Value of 1 indicates LA27. Value of 0 indicates GPIO4.	Yes	Yes	1
13	GPIO4 Direction. Value of 0 indicates input. Value of 1 indicates output. Always an output if LA27 is selected.	Yes	Yes	0
14	GPIO4 Data. If programmed as output, writing 1 causes corresponding pin to go high. If programmed as input, reading provides state of corresponding pin.	Yes	Yes	0
15	GPIO5 or LA26 Pin Select. Selects the function of GPIO5/LA26 pin. Value of 1 indicates LA26. Value of 0 indicates GPIO5.	Yes	Yes	1
16	GPIO5 Direction. Value of 0 indicates input. Value of 1 indicates output. Always an output if LA26 is selected.	Yes	Yes	0
17	GPIO5 Data. If programmed as output, writing 1 causes corresponding pin to go high. If programmed as input, reading provides state of corresponding pin.	Yes	Yes	0
18	GPIO6 or LA25 Pin Select. Selects the function of GPIO6/LA25 pin. Value of 1 indicates LA25. Value of 0 indicates GPIO6.	Yes	Yes	1
19	GPIO6 Direction. Value of 0 indicates input. Value of 1 indicates output. Always an output if LA25 is selected.	Yes	Yes	0
20	GPIO6 Data. If programmed as output, writing 1 causes corresponding pin to go high. If programmed as input, reading provides state of corresponding pin.	Yes	Yes	0
21	GPIO7 or LA24 Pin Select. Selects the function of GPIO7/LA24 pin. Value of 1 indicates LA24. Value of 0 indicates GPIO7.	Yes	Yes	1
22	GPIO7 Direction. Value of 0 indicates input. Value of 1 indicates output. Always an output if LA24 is selected.	Yes	Yes	0
23	GPIO7 Data. If programmed as output, writing 1 causes corresponding pin to go high. If programmed as input, reading provides state of corresponding pin.	Yes	Yes	0
24	Reserved.	Yes	Yes	0
25	GPIO8 Direction. Value of 0 indicates input. Value of 1 indicates output.	Yes	Yes	0
26	GPIO8 Data. If programmed as output, writing 1 causes corresponding pin to go high. If programmed as input, reading provides state of corresponding pin.	Yes	Yes	0
31:27	Reserved.	Yes	Yes	0h

This diagram is taken from the PLX9030 Data Book v1.4.

Specifications

Operating Environment

Storage temperature: -40° C to 125° C
Operating temperature: -40° C to 85° C
Humidity: 95%, non-condensing

Power Requirements

+5 VDC @ 500mA (maximum)
380 mA (minimum)

NOTE:

External power output pins on each CAN port is limited up to 125 mA per port .

PC Bus Interface

PC/104-Plus

Optical/Power Isolation

3kV for each CAN port from the host system and other isolated CAN ports.

Dimensions

Compliant to PC/104-Plus specification 2.2

Connectors/Interface

Standard: 10-pin, right angled header
Optional: DB-9

GPIO

8-bit 3.3V I/O header

Certification

Certification for CANpro/104-Plus Opto

The CANpro/104-Plus Opto product family is to be included into a device ultimately subject to FCC, DOC/IC, and CE certification. The customer is responsible for bringing the completed device into compliance prior to resale.

Connect Tech has designed CANpro/104-Plus Opto with EMI and EMC considerations such as:

Ground and power planes

Controlled slew-rate signals

EMI/EMC reducing PCB layout

Limited Lifetime Warranty

Connect Tech Inc. provides a Lifetime Warranty for all Connect Tech Inc. products. Should this product, in Connect Tech Inc.'s opinion, fail to be in good working order during the warranty period, Connect Tech Inc. will, at its option, repair or replace this product at no charge, provided that the product has not been subjected to abuse, misuse, accident, disaster or non Connect Tech Inc. authorized modification or repair.

You may obtain warranty service by delivering this product to an authorized Connect Tech Inc. business partner or to Connect Tech Inc. along with proof of purchase. Product returned to Connect Tech Inc. must be pre-authorized by Connect Tech Inc. with an RMA (Return Material Authorization) number marked on the outside of the package and sent prepaid, insured and packaged for safe shipment. Connect Tech Inc. will return this product by prepaid shipment service.

The Connect Tech Inc. lifetime warranty is defined as the serviceable life of the product. This is defined as the period during which all components are available. Should the product prove to be irreparable, Connect Tech Inc. reserves the right to substitute an equivalent product if available or to retract lifetime warranty if no replacement is available.

The above warranty is the only warranty authorized by Connect Tech Inc. Under no circumstances will Connect Tech Inc. be liable in any way for any damages, including any lost profits, lost savings or other incidental or consequential damages arising out of the use of, or inability to use, such product.

Customer Support Overview

If you experience difficulties after reading the manual and/or using the product, contact the Connect Tech reseller from which you purchased the product. In most cases the reseller can help you with product installation and difficulties.

In the event that the reseller is unable to resolve your problem, our highly qualified support staff can assist you. Our online Support Center is available 24 hours a day, seven days a week on our website at: www.connecttech.com/sub/support/support.asp. Please go to the [Download Zone](#) or the [Knowledge Database](#) for product manuals, installation guides, device driver software and technical tips. Submit your questions to our technical support engineers at support@connecttech.com. Our technical support is always free.

Contact Information

Telephone/Facsimile

Technical Support representatives are ready to answer your call Monday through Friday, from 8:30 a.m. to 5:00 p.m. Eastern Standard Time. Our numbers for calls are:
Toll: 800-426-8979 (North America only) | Tel: 519-836-1291 | Fax: 519-836-4878 (online 24 hours)

Email/Internet

You may contact us through the Internet. Our email and URL addresses are:
sales@connecttech.com | support@connecttech.com | www.connecttech.com

Mail/Courier

Connect Tech Inc.
42 Arrow Road
Guelph, Ontario, N1K 1S6, Canada

Free Manuals Download Website

<http://myh66.com>

<http://usermanuals.us>

<http://www.somanuals.com>

<http://www.4manuals.cc>

<http://www.manual-lib.com>

<http://www.404manual.com>

<http://www.luxmanual.com>

<http://aubethermostatmanual.com>

Golf course search by state

<http://golfingnear.com>

Email search by domain

<http://emailbydomain.com>

Auto manuals search

<http://auto.somanuals.com>

TV manuals search

<http://tv.somanuals.com>