

Product Manual

ICC2-IRC / ICW-IRC

IR TV Controller

Ver. 2.5 October 30, 2002



17630 Davenport Rd, Suite113
Dallas, TX 75252 USA

Tel: 972.931.2728
888.972.2728

Fax: 972.931-2765

Web: www.crwww.com
www.contemporaryresearch.com

Table of Contents

Overview	3
Specifications	4
Physical	4
Front Panel	4
Rear Panel	4
Internal Closures	4
RF Tuner	5
iCC-Net (ICC2-IRC).....	5
iCW-Net (ICW-IRC)	5
CC-HSD Scan Sensor	5
Status Indication	5
Installation	6
AC Power.....	6
RF Coax and iCC-Net Operation	6
iCW-Net Connection (ICW-IRC)	6
TV Power Sensing	6
A/V Setup	7
IR Control Wiring	7
IR Mode and Power Sensing.....	7
Programming the IC-RC Remote.....	7
On-Screen Setup Menus.....	8
RS-232 Control Protocol	9
Overview	9
Command String Structure	9
RS-232 Commands	10
RS-232 Responses	13
Response String Structure.....	13
iC-Net Zones	15
System Map	16
Typical RF and ICC-Net Signal Flow	17
iCW-Net Wiring	18
Mounting the IRC	19
Safety Instructions	20
Limited Warranty and Disclaimer	21

Overview

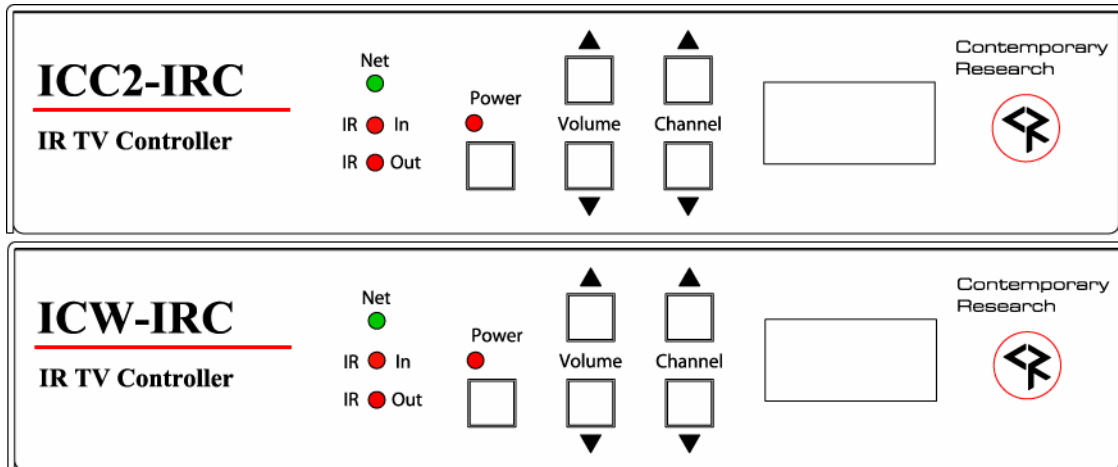

Contemporary Research offers two solutions for intelligent, interactive distributed media management, the ICC2-IRC and ICW-IRC IR TV Controllers. The ICC2-IRC communicates bi-directionally over the same RF coax that carries the broadband TV channels, dramatically simplifying system wiring. The ICW-IRC connects over a twisted-pair network using Category 5 or Category 3 wiring and connectors.

Both IRC TV Controllers feature an internal TV tuner for absolute channel access management and a character generator that outputs on-screen text for channel names, control functions, and interactive menus. Intelligent tuning, volume and power control is provided by IR control port and included scan sensor. Front-panel control and LEDs keep users in touch with their system. Enjoy a full range of control choices with the included IC-RC IR Wireless Remote, designed for simplified control of distributed media channels and sources.

Compatible with the Contemporary Research ABC Media Retrieval System and iC Commander software, the IRC TV Controllers can be networked with up to 4000 TV and Video Display controllers. For custom systems applications, all IRC units and other iC-Net devices can be accessed from a single RS-232 port on ICC-HE and ICW-HE Head-End Network Controllers.

- Controls most brands of TVs from IR control port
 - Creates on-screen channel labels, messages, text menus, and feedback using onboard character generator
 - Receives wireless commands from included IC-RC IR remote from internal IR sensors, external sensor optional
 - Delivers absolute volume control for level and mute
 - Manages channel access using programmable available channel list
 - Delivers absolute power control with included power sensor
- Networks with up to 4,000 TVs through an ICC-HE or ICW-HE Head-End Network Controller
 - ICC2-IRC units provide 2-way operation over the same RF cable as CATV channels
 - ICW-IRC connect over Category 3 or 5 wiring
 - Units instantly respond to individual, zone, and all-call commands
- Provides front-panel control for power, volume, and channel, and LED feedback for power, IR control, and network
- Includes A/V inputs to display video from PCs, overheads, cameras and other local video sources
- Restores all operation status after loss of power from data stored in non-volatile memory
- Enables and disables front-panel control via iC-Net protocol
- Mounts above, below, or near TV, mounting brackets included over the same RF coax as the distributed media channels, simplifying system wiring and retrofit

Specifications

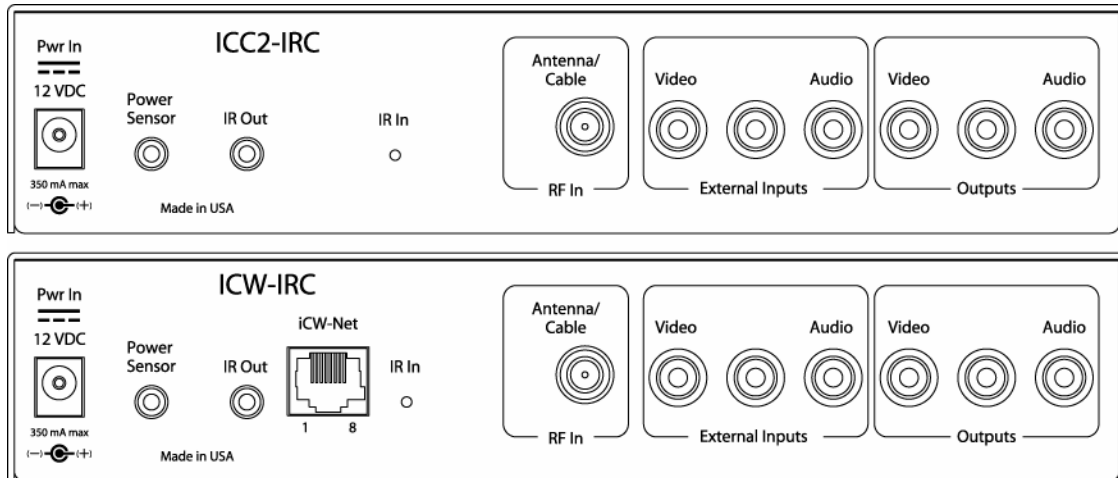

Physical

Size:	8.5" [216mm] wide x 1.75" [38mm] height (1RU) x 6.0" [153mm] deep
Weight:	1.5 lbs [0.68kg]
Enclosure:	All aluminum with durable black powder coat paint
Mounting:	Mounts above or below TV, optional RK2 brackets available

Front Panel

Push Buttons:	Channel up and down, Volume up and down, and Power
Power LED:	Red LED lights when TV is on
Net LED:	Green LED for iC-Net bus, flashes once per second if active
IR In LED:	Red LED lights when receiving IR commands from remote
IR Out LED:	Red LED lights when sending IR commands
Volume Up/Down:	Buttons adjust volume of IRC audio output
Channel Up/Down:	Buttons select list of channels stored in IRC Tune Ring

Rear Panel

Power In:	2.1mm coaxial jack (inside center conductor positive), 350 Ma maximum 11.5 to 16.5 VDC, 12 VDC typical (may be unregulated) North American version includes UL/CSA listed wall power supply
Power Sensor:	3.5mm jack for optional CC-HSD scan sensor or 5V logic-level input
IR Out:	3.5mm jack for CC-IRE IR Emitter cable or compatible CC-IRS serial cable Supports carrier frequencies up to 62 KHz Shipped with CC-IRE cable, 10 foot with stick-on IR emitter
Antenna/Cable:	'F', female, 75 ohm impedance
A/V Inputs:	Video - RCA female, NTSC composite Audio - 2 RCA female, mono 20K ohms unbalanced
A/V Outputs:	Video - RCA female, NTSC composite Audio - 2 RCA female, mono 1K ohms, 20Hz to 20KHz 0.5% maximum, 0.1% typical THD, 500mV RMS typical at max volume Volume control 0 to -62 dB and mute in 64 steps
IR In	Mounting hole for optional external IR sensor input jack

Internal Closures

Type:	2 Solid-State output switch closures, max 50 mA, 24 VDC Closure 1 normally used for optional buzzer Closure 2 normally used for an external camera power relay (by others) Available as factory-installed option only
-------	--

RF Tuner

Frequency Range: NTSC television 55.25 to 801.25 MHz, 62.5KHZ fine tune resolution
Maximum Input: +20dBmV
Video Gain: ±5% maximum, 2% typical
Video Phase: ±3 degrees maximum, 2 degrees typical

iCC-Net (ICC2-IRC)

Operation: Carried over the same RF coax connection as TV channels
Data Receive: Mid-band VHF, 74.7MHz, sent from IC Head-End Network Controller
-25 to +35 dBmV signal level
Data Transmit: Sub-band, 5.6MHz sent to Head-End Network Controller
± 80 KHz max carrier deviation
+49dBmV nominal

iCW-Net (ICW-IRC)

Connector: RJ-45 female 8 pin Telco jack
RS-485 type data requiring at least 2 twisted wire pairs with shield or fifth conductor
Recommended Wire: CAT3/CAT5 compatible unshielded, max 3300 feet [914m] from iC Head End

CC-HSD Scan Sensor

Range: Senses presence of TV scanning, from 15-35 KHz, magnetic pick-up
Includes: 3.5mm plug, 4ft. cable, stick-on TV sensor

Status Indication

The Net and Power LEDs have special modes that help system setup and troubleshooting.

Power LED Uses a blink mode when the IRC logic and Sensor feedback do not agree

Logic	Sensor	LED Response
ON	ON	Solid On
ON	OFF	Blinks – states do not agree
OFF	OFF	Solid Off
OFF	ON	Blinks – states do not agree

For example, if the TV Controller knows the TV should be on, but the sensor input does not see scanning activity, the Power LED blinks rapidly.

Net LED Blinks when it is receiving network data

LED Response
Off – DC power to IRC missing or other internal power problem
Solid On – no network communication
Blinks once per second - communicating over network

The Head-End Network Controller sends out a "heartbeat" command once every second that will flash the Net LED.

Installation

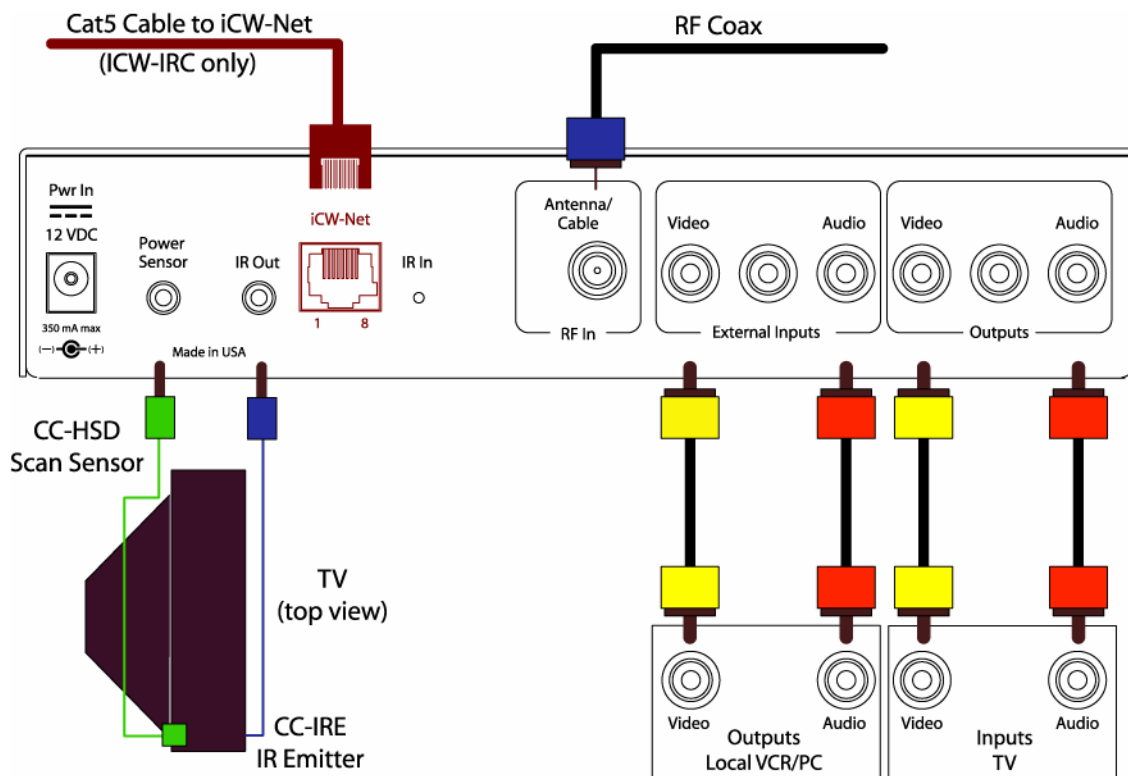

AC Power

1. Insert DC power supply plug into 12 VDC jack on the IRC.
2. Plug power adaptor into AC wall outlet.
3. The Net LED should turn on and stay lit.

RF Coax and iCC-Net Operation

1. Connect the RF Coax cable into the Antenna/Cable input on the IRC.
2. If the iCC-Net signal is operating, the Net LED will blink once per second (ICC2-IRC only).

iCW-Net Connection (ICW-IRC)

1. Plug the iCW-Net RJ-45 connector into the iCW-Net input on the ICW-IRC.
2. If the iCW-Net signal is operating, the Net LED will blink once per second.

TV Power Sensing

1. Press the Power button on the IRC.
2. The Power LED should blink, indicating that the IRC knows the TV should be on, but is not sensing the presence of TV scanning operation.
3. Insert the CC-HSD Scan Sensor plug into the IRC Power Sensor jack.
4. Turn on the TV using the TV's power button.
5. Move the CC-HSD sensor block around the rear of the TV to pick up scanning signal from the TV's horizontal transformer
6. Watch the IRC Power LED as you move the sensor, stop moving when the LED stops blinking.
7. Turn the TV on and off from its own power button, testing if the IRC is reliably sensing power.
8. Mount the sensor to the TV, using the enclosed Velcro tape.

Tip: The best location for the sensor is usually on the lower left rear corner side corner (looking from the front), and it may help to rotate the sensor to search for best performance.

A/V Setup

1. Connect audio and video outputs of the IRC into the audio and video inputs of the TV.
2. You may use the left or right IRC audio output for a TV with mono audio, both for a TV with stereo audio (IRC sound is mono).
3. Select the External Video/Aux inputs on the TV to view on-screen setup commands and A/V from the IRC (Most TVs don't have a discrete Video input command).

IR Control Wiring

1. Connect the CC-IRE IR Emitter plug into the IRC IR Out jack.
2. Mount the emitter cube to the TV case where the TV receives IR commands.
3. Place the IRC near the TV within line-of-sight control from the IC-RC wireless IR remote. At this point, you could fix the IRC into the final mounting position above or below the TV, or simply place the IRC so you can complete the IR setup procedure.

Tip: At this point, you've set up the control wiring, the manufacturer's codes sent will be programmed or changed with the On-Screen Setup Menu 45700. Press the Power button on the IRC. If the TV turns on and off, the settings are already correct.

IR Mode and Power Sensing

Newer IRC models set the IR and Sensing options via the On-Screen Setup Menu 45702. Some ICW-IRC units include a DIP switch (S6), located inside the IRC, to set IR options and TV Power sensing. Note this affects the front-panel sensing, not an external IR sensor. Turning off both sensors would limit sensing to the external IR sensor only. If you have two adjacent TVs (or one on each side of a wall), you may want to lower TV power sensing. Some TVs prefer a lower IR output, most work fine with the standard level.

Switch #	Function	Options
1	38 KHz IR Receive	ON= 38 KHz IR OFF= 38 KHz IR off (default)
2	57 KHz IR Receive	ON= 57 KHz IR (default) OFF= 57 KHz IR off
3	TV Power Sensing	ON= High sensitivity (default) OFF= Low sensitivity
4	IR Control Output	ON= High IR output (default) OFF= Low IR output

Programming the IC-RC Remote

In order to complete the setup of the IRC, you'll need the IC-RC IR Remote to use the On-Screen Menus. Typically, the remote is shipped ready to communicate to the IRC (Code 9). Just in case, here's how to set the format of IR codes in the remote:

1. Press and hold the Select button and a numeric key for the code # below.
2. Release the two keys at the same time.
3. The remote will now send the selected codes.
4. Remote will keep the codes, even if battery power is lost.

IR Code Format	Code
Zenith Smart TV	1
Philips Smart TV	2
RCA Smart TV	3
Contemporary Research 38 KHz	4
Contemporary Research 57 KHz (default)	9

Tip: Normally, the 57 KHz frequency works the best, avoiding most sources of IR interference. The IRC has 38 KHz and 57 KHz sensors, so it can receive either frequency.

On-Screen Setup Menus

The remaining installation steps use the IR remote and the built-in character generator of the IRC.

1. Touch **Menu**, then **999**, then **Enter**.
2. The text **CR MENU>** should appear on the screen.
3. Key in one of the commands shown below, then press **Enter** to activate.
4. Note that, in Menu mode, the **Channel Down** key acts as a backspace/delete key.

Command	Function
All	The following commands are used for all IRCs
45678	Display IRC firmware version
45679	Display the unit's Device #. At this point, you can use the Channel Down key as a Delete key, enter a new device # with the remote's numeric keypad, then hit Enter to save the new number.
45700	Display or edit IR device type. Sets the IR control format to match your TV. In many cases, CR can pre-set this command to the format specified by the dealer. 0=None 1=Zenith [added V2.0] 2=Panasonic [added V1.7] 3=Toshiba [added V2.0] 4=Hitachi [added V2.0] 5=Sony [added V2.0] 6=Grundig [added V2.0] 7=Magnavox/Philips [added V1.7] 8=RCA [added V2.0] 9=Sony_2 [added V2.0] 10=Panasonic_2 [added V1.9] 11=Mitsubishi [added V2.0] 12=Monivision (old) [added V1.6] 13=Monivision (new) [added V1.8] 14=Panasonic_3 [added V1.9] 15=Sharp [added V2.1] 16=Pioneer (plasma) [added V2.3] 17=NEC (plasma) [added V2.3] 18 = Samsung [added 2.5]
45702	Set IR receive, IR output and power sensing levels. 1 = Enable 38KHz IR receive in, 0=disable 2 = Enable 57KHz IR receive in, 0=disable 4 = Enable IR output carrier, 0=no carrier 8 = Set power sensor for high sensitivity, 0=low sensitivity 16 = Set IR output for high current, 0=low current Add up the values and enter the result. For example, the default setting is 30 (57 KHz on, IR carrier, high power sensitivity, and high IR output).
65478	Reset IRC, similar to disconnecting power then restarting.
65487	Initialize IRC to factory default settings: Power on, unlocked, display channel 11, channel ring set to 4, 5, and 11, Group 0. Note that this command works even if TV power is off or control is locked out.
65482	Shows Net RX if receiving the iC-HE's "heartbeat" pulse once per second, !NET RX if not. Also displays receive signal strength in the ICC2-IRC.
ICC2-IRC	The following commands are used for the ICC2-IRC only
65480	Enable constant Net transmit to the Head-End. This is used for measuring the signal strength of the ICC2-IRC's RF output. Press Enter to stop transmitting, or the unit will automatically stop after 50 seconds.
65481	Display ICC2 transmitter frequency control voltage – should be 2000 - 3150.
65483	Display DF transmitter frequency deviation – should be 245 - 300.

RS-232 Control Protocol

Overview

RS-232 control for up to 4000 ICC2-IRC and ICW-IRC TV Controllers is provided through an iC-series Head-End Network Controller. The ICC-HE Head-End manages iC-Net communication over RF Coax to ICC2-IRC TV Controllers as well as ICW-IRC TV Controllers over twisted-pair Cat3/5 wiring. The ICW-HE Head-End operates on the twisted-pair network only.

Each TV Controller is assigned a unique device number from 1 to 4000 to which control commands are addressed. The devices are organized into 16 zones of 255 devices. All the devices in each zone will respond to a single "virtual device number" — one device number that represents all devices in each zone. There is also a global device number, 4095, that will command all devices in the system. This feature dramatically speeds up system operation and programming, because one command can affect an entire group of devices—or all. To take advantages of this feature, review the section **iC-Net Zones** in this manual.

In ABC Media Retrieval Systems, we reserve the first group of devices, 1-255, for components operating on a connected control system. Zones 1-16 are used for CR TV Controllers, Video Display Controllers and Tuners. As it's unlikely any system will use all 4000 devices, this may be a good device standard for your system as well.

The Remote RS-232 port on the Head-End Network Controller can communicate from 1200 to 38.4K baud. The factory default setting is 19.2K baud, 8 data bits, No parity, and 1 stop bit.

Command String Structure

Characters in command strings are expressed in a combination of hex and ASCII characters. For clarity, the following protocol examples use the following conventions:

- Single-byte hex numbers are preceded by the '\$' symbol
- ASCII characters or strings are enclosed in single quotes
- Numbers not marked as hex or ASCII are a single decimal byte
- Parameters shown in < > brackets are single byte
- A series of multiple commands or parameters are set apart by [] brackets
- Commas separate the bytes, but are not part of the protocol
- Double quotes enclose the command string, but are not part of the protocol

Command format:

"\$A5,<dh>,<dl>,<ncb>,<cmd1>,<parameter> [<cmdN>]"

\$A5	Starts the command
<dh>	The zone or high order byte of the device
<dl>	The unit or low order byte of the device (0 for global zone)
<ncb>	The number of command bytes to follow
<cmd1>	The first command byte
<parameter>	Command parameters (not used by all commands)
[<cmdN>]	Multiple commands can be concatenated, with byte count added to <ncb>

RS-232 Commands

Command		Description
Power Off	PO	"\$A5,<dh>,<dl>,2,'P0' " (6 bytes) – checks sensor for true power control
Power On	P1	"\$A5,<dh>,<dl>,2,'P1' " (6 bytes) – checks sensor for true power control
Power Toggle	PT	"\$A5,<dh>,<dl>,2,'PT' " (6 bytes) – checks sensor for true power control
Operating Parameters	TM	"\$A5,<dh>,<dl>,3,'TM',<setting>" (7 bytes) Sets up key functions in the IRC bit 7 – 3 = 0 bit 2 – Channel up/down operation, 0=Tune Ring, 1=Send IR Keypad response bit 1 – Numeric channel labels, 0=num labels off, 1=num labels on) bit 0 – Alpha channel labels, 0=alpha labels off, 1=alpha labels on
Volume	VL	"\$A5,<dh>,<dl>,3,'VL',<vol level>" (7 bytes) Sets IRC volume level 0 = Mute 1 – 63 = Minimum level (1) to maximum volume (63)
Power-up Volume	S5	"\$A5,<dh>,<dl>,3,'S5',<volume>" (7 bytes) Sets volume level when IRC powers up 0 = restore to previous level 1 – 63 = Set from minimum (1) to maximum level (63)
Ts & Qs		<i>T-series channel commands select a channel and display the channel label on the TV, while Q-series commands don't show the on-screen text.</i>
T Channel Up	TU	"\$A5,<dh>,<dl>,2,'TU' " (6 bytes) – Tunes to next channel up in Tune Ring
T Channel Dwn	TD	"\$A5,<dh>,<dl>,2,'TD' " (6 bytes) – Tunes to next channel down in Tune Ring
Force T Channel	TC	"\$A5,<dh>,<dl>,3,'TC', <channel>" (7 bytes) – Tunes to a specific channel 124 = RGB 2 input on TV 125 = RGB input on TV 126 = Select IRC external A/V input (also selects TV video input) 127 = Select S-Video Input 0 = Blank video output to TV 255 = Unblank TV video (restore to previous channel) Tip: Not all inputs are available on every TV make and model.
Select T Channel	TT	"\$A5,<dh>,<dl>,2,'TT' " (6 bytes) – Tunes channel if included in Tune Ring
Channel Query	T?	"\$A5,<dh>,<dl>,2,'T?' " (6 bytes) – Request response for current channel
Q Channel Up	QU	"\$A5,<dh>,<dl>,2,'QU' " (6 bytes) – Tunes to next channel up in Tune Ring
Q Channel Dwn	QD	"\$A5,<dh>,<dl>,2,'QD' " (6 bytes) – Tunes to next channel down in Tune Ring
Force Q Chan	QC	"\$A5,<dh>,<dl>,3,'QC', <channel>" (7 bytes) – Tunes to a specific channel Same special-function channels as in the T Channel Select section above
Select Q Chan	QT	"\$A5,<dh>,<dl>,2,'TT' " (6 bytes) – Tunes channel if included in Tune Ring

Command		Description
Tuner Mode	SO	<p>"\$A5,<dh>,<dl>,3,'S0',<tune mode>" (7 bytes)</p> <p>Sets tuner mode to CATV or Broadcast/Antenna 0 = CATV 1 = Broadcast/Antenna 2 = HRC</p>
Tune Ring	TR	<p>"\$A5,<dh>,<dl>,<ncb>,'TR', [<chan 1>, <chan N>]" (variable bytes)</p> <p>This command stores a Tune Ring, a series of preset channels accessed by channel up/down commands.</p> <p>Ex1: "\$A5,<dh>,<dl>,6,'TR', 5,4,8,11" sets ring to channels 5, 4, 8 and 11 Tip: The ring follows the stored order, channels do not have to be in ascending order Ex2: "\$A5,<dh>,<dl>,2,'TR' " clears the Tune Ring, locks unit to current channel Tip: In the above mode, the IR Keypad channel up/down response to the Head-End, so the system will know the user is trying to change channels. In response, the system could change channels on a media sources, like a VCR or satellite. Ex3: "\$A5,<dh>,<dl>,8,'TR', \$82,5,\$87,11" sets channels 2-5 and 7-11. You can specify a range using MSB bit for the first channel; the next byte is the last.</p>
Channel Labels	TN	<p>"\$A5,<dh>,<dl>,<ncb>,'TN',<channel>,<label>" (variable bytes)</p> <p>Stores an ASCII string as the channel label. The text will appear briefly when the channel is selected, if the feature has been activated by IRC Setup command (TM).</p> <p>Ex1: "\$A5,<dh>,<dl>,3,'TN', '7', 'PBS' " IRC displays PBS when 7 is selected Ex2: "\$A5,<dh>,<dl>,3,'TN', '7' " Clears alpha label for channel 7 Ex3: "\$A5,<dh>,<dl>,3,'TN',0,0" Clears all alpha labels</p>
Display Label	TC	<p>"\$A5,<dh>,<dl>,2,'TC' " (6 bytes) – Display current channel label for about 15 seconds</p>
Closures	Y-	<p>"\$A5,<dh>,<dl>,3, 'Y' <I/O Port>' " (7 bytes)</p> <p>Turns the two internal closures on and off. Closure 1 is typically used to control the optional buzzer, Closure 2 typically used to control an external camera power relay.</p> <p>"\$A5,<dh>,<dl>,3, 'Y10'" turns Closure 1 off "\$A5,<dh>,<dl>,3, 'Y11'" turns Closure 1 on "\$A5,<dh>,<dl>,3, 'Y20'" turns Closure 2 off "\$A5,<dh>,<dl>,3, 'Y21'" turns Closure 2 on</p>
Control Lock	LM	<p>"\$A5,<dh>,<dl>,3,'LM',<control>" (7 bytes)</p> <p>Locks out front panel and IR remote control functions.</p> <p>Bit 7 Selects IR remote control operation (0=enabled, 1=disabled) Bit 6 Selects volume control operation (0=enabled, 1=disabled) Bit 5 - 1 Always 0 Bit 0 Selects IRC front panel buttons operation (0=enabled, 1=disabled)</p>
Device Status	SP	<p>"\$A5,0,0,3,'SP'" (6 bytes)</p> <p>Queries the Head-End for the number of devices present on the network and the number of devices expected.</p>

Command	Description
Write Text	<p>DM "\$A5,<dh>,<dl>,<ncb>,'DM', <start line>,<text color>,<background color>,<background>,<size and shadow>,<timeout>,<message bytes>" (variable bytes)</p> <p>Clears current text, displays text message over video (default) or blank background. The built-in character generator can accept up to 40 characters of text (including carriage returns), 28 characters per line. Use a hex \$0D or decimal 13 in the text as a carriage return, which will advance CG to the next line, first space on the right.</p> <p>Start Line - 1-11 Text Color - 1-7= White Text Background Color – 0-7=Transparent (no background) Full screen background – 0=normal insert over video, 1=blank screen (blue) Size and Shadow – 0-3=small text with drop shadow Time-Out – 0=15-second display, 1=persistent Persistent text stays on screen until the next DM, or new Menu or channel.</p> <p>Ex1: "\$A5,<dh>,<dl>,10,'DM', 2,7,0,0,1,0,'TEST' " displays the word TEST on the second line, white text, inserted over video, small size with drop shadow, and timing out after 15 seconds.</p> <p>Ex2: "\$A5,<dh>,<dl>,2,'DM' " clears on-screen display, also clears persistent text</p> <p>The VDC uses white text and clear backgrounds when it receives a Text or Background Color parameter between 1 and 7, and accepts values 0-3 for text size and shadow. This allows compatibility with Smart TVs mixed in the same system that can display other colors and fonts.</p>
Fast Write	<p>DN "\$A5,<dh>,<dl>,<ncb>,'DN', <text> " (variable bytes)</p> <p>Clears display, writes specified text starting at column 1, row 1. \$0D and hex \$EA, \$EB, \$DC, and \$DB can be included, operate same as matching commands below.</p>
Write Here	<p>DW "\$A5,<dh>,<dl>,<ncb>,'DW', <text> " (variable bytes)</p> <p>Writes specified text starting at present cursor position. Accepts same Hex as DN.</p>
Row, Column	<p>DG "\$A5,<dh>,<dl>,4,'DG', <row>, <column>" (8 bytes)</p> <p>Moves the cursor to the specified row and column position. If row is 0, then row will not be changed, and if column is 0, then column will not be changed.</p>
Cursor Column	<p>E7 "\$A5,<dh>,<dl>,3,'E7', <column>" (7 bytes) – sends cursor to specified column.</p>
Cursor Row	<p>E8 "\$A5,<dh>,<dl>,3,'E8', <row>" (7 bytes) – sends cursor to specified row.</p>
Return	<p>EB "\$A5,<dh>,<dl>,2,'EB' " (6 bytes)</p> <p>Moves cursor down to the first column of the next row.</p>
Clear All	<p>EA "\$A5,<dh>,<dl>,2,'EA' " (6 bytes)</p> <p>Clears display, sends cursor to column 1, row 1.</p>
Clear to End	<p>DC "\$A5,<dh>,<dl>,2,'DC' " (6 bytes)</p> <p>Clear on-screen display from cursor to end of screen, position stays the same.</p>
Clear Line	<p>DB "\$A5,<dh>,<dl>,2,'DB' " (6 bytes)</p> <p>Clear on-screen display from cursor to end of line, cursor position stays the same.</p>
Clear Spaces	<p>E9 "\$A5,<dh>,<dl>,3,'E9', <num spaces>" (7 bytes)</p> <p>Clears specified number of spaces, starting from cursor to the right.</p>
Text Timeout	<p>DQ "\$A5,<dh>,<dl>,3,'DQ', <time>" (7 bytes)</p> <p>Sets screen timeout to specified time in seconds (1-254). If time is 0 or 255, any text on the screen will persist indefinitely, or until cleared.</p>

RS-232 Responses

iC-Net devices will send a response over the network whenever there is a change in status or command from an IR remote or front panel.

Response String Structure

Characters in response strings are expressed in a combination of hex and ASCII characters. For clarity, the following protocol examples use the following conventions:

- ASCII characters or strings are shown enclosed in single quotes
- Numbers shown that are not in single quotes are a single decimal byte
- Parameters shown in < > brackets are single byte
- A series of multiple commands or parameters are set apart by [] brackets
- Commas separate the bytes, but are not part of the protocol
- Double quotes enclose the command string, but are not part of the protocol

Command format:

" `<'<dh>,<dl>,<nrb>,<rb1>,<para1> [<rbN>]"

`>' Starts the response
 <dh> The zone or high order byte of the device
 <dl> The unit or low order byte of the device (0 for global zone)
 <nrb> The number of response bytes to follow
 <rb1> The first response byte
 <para1> Associated parameters, if any
 [<rbN>] Multiple responses may be included

Response		Description
New Channel	T	" `<'<dh>,<dl>,2,'T',<new channel>" (6 bytes) Sent in response to T? command.
IR Function	F	" `<'<dh>,<dl>,2,'F',<IR Function>" (6 bytes) Sent when unit receives a new function command is pressed (1-8) or released (0) from the IR remote. 0 = Release 1 = Play 2 = Stop 3 = Pause 4 = Fast Forward 5 = Rewind 8 = Record

Response	Description														
IR Key	<p data-bbox="440 163 943 199">K "`<',<dh>,<dl>,2,'K',<IR Key>" (6 bytes)</p> <p data-bbox="440 226 1458 289">Sent when unit receives a new key command is pressed (10-116) or released (0) from the IR remote.</p> <table data-bbox="440 321 1187 548"> <tr> <td>0 = Release</td> <td>105 = Media Menu</td> </tr> <tr> <td>10 - 19 = Numeric keypad entry 0 – 9</td> <td>106 = Cursor Right</td> </tr> <tr> <td>21 = Enter</td> <td>107 = Cursor Left</td> </tr> <tr> <td>22 = Channel Up</td> <td>108 = Cursor Up</td> </tr> <tr> <td>23 = Channel Down</td> <td>109 = Cursor Down</td> </tr> <tr> <td>29 = Menu</td> <td>110 = Media Select</td> </tr> <tr> <td>101 = Previous Channel</td> <td>116 = Timer</td> </tr> </table> <p data-bbox="440 579 1458 674">The 0 – 9, Channel Up/Down functions are sent only if enabled in the TM command (Bit 2 = 1). The Channel Up/Down responses will be sent if the Tune Ring contains no channels – see Ex2 in the Tune Ring command section.</p>	0 = Release	105 = Media Menu	10 - 19 = Numeric keypad entry 0 – 9	106 = Cursor Right	21 = Enter	107 = Cursor Left	22 = Channel Up	108 = Cursor Up	23 = Channel Down	109 = Cursor Down	29 = Menu	110 = Media Select	101 = Previous Channel	116 = Timer
0 = Release	105 = Media Menu														
10 - 19 = Numeric keypad entry 0 – 9	106 = Cursor Right														
21 = Enter	107 = Cursor Left														
22 = Channel Up	108 = Cursor Up														
23 = Channel Down	109 = Cursor Down														
29 = Menu	110 = Media Select														
101 = Previous Channel	116 = Timer														
IR Menu	<p data-bbox="440 674 1219 709">M "`<',<dh>,<dl>,5,'M',<msh>, <msl>, <mph>, <mpl>" (9 bytes)</p> <p data-bbox="440 741 1472 835">Sent when IRC receives a new Menu command is pressed or released (0) from the IR remote. Menu Selection high and low bytes are in <msh> and <msl>. Menu Parameter high and low bytes are in <mph> and <mpl>.</p> <p data-bbox="440 867 1446 961">A Menu command is initiated by pressing the Menu key, followed by a numeric entry, then the Enter or Channel Up key. During the Menu process, the Channel Down key acts as a backspace or delete key.</p> <p data-bbox="440 993 1463 1056">Some selections that need only a single numeric entry and will have a parameter value of zero (0). Those keys are 0, 8, 9, 18, 20, 30, 900, 911, and 912.</p> <p data-bbox="440 1087 1393 1119">Menu selections that will prompt the user to enter a second parameter entry are:</p> <table data-bbox="440 1150 675 1472"> <tr><td>1 = Select Media</td></tr> <tr><td>2 = Password</td></tr> <tr><td>3 = Chapter Search</td></tr> <tr><td>4 = Frame Search</td></tr> <tr><td>11 = Channel</td></tr> <tr><td>21 = Page Zone</td></tr> <tr><td>22 = Page Room</td></tr> <tr><td>25 = Go</td></tr> <tr><td>21 = Attach Zone</td></tr> <tr><td>32 = Attach Room</td></tr> </table> <p data-bbox="440 1503 1154 1535">Tip: The Menu entries are active even if the TV power is off.</p>	1 = Select Media	2 = Password	3 = Chapter Search	4 = Frame Search	11 = Channel	21 = Page Zone	22 = Page Room	25 = Go	21 = Attach Zone	32 = Attach Room				
1 = Select Media															
2 = Password															
3 = Chapter Search															
4 = Frame Search															
11 = Channel															
21 = Page Zone															
22 = Page Room															
25 = Go															
21 = Attach Zone															
32 = Attach Room															
Device Response	<p data-bbox="440 1570 1393 1606">SP "`<',0,0,4,'SP',<number devices present>,<number devices expected> (8 bytes)</p> <p data-bbox="440 1638 873 1669">Sent in response to HE status query.</p> <p data-bbox="440 1701 1472 1789">Tip: If the number of present and expected devices match, the green Net LED on the HE will blink once per second. If the two numbers do not agree, the LED blinks twice per second.</p>														

iC-Net Zones

To simplify controlling groups of devices, iC-Net is divided into 16 zones of 255 devices. All the devices within each zone can be controlled simultaneously by sending a command to a single "virtual device number".

For example, noting the zone chart below, if we send a Power On command to device #256, any TV controller numbered between 257 and 511 will instantly turn on. If we send a Power Off command to device #4095, all devices in the system will turn off.

This is an immensely powerful feature, because most systems can only address one device at time. So if you need to turn off all 50 TV in a zone, you would need to send 50 commands. In addition to the hassles of creating multiple commands, there would be a long delay between the first and last command. One command, instant response is easier.

As we noted before, ABC Media Retrieval Systems reserve Zone 0 for devices used in the central control system, 1 -15 for iC-Net devices. This structure may be useful for your application, or you could use Zone 0 just like any other iC-Net zone.

Zone	First Device	Last Device	Virtual Device
0	1	255	0
1	257	511	256
2	513	767	512
3	769	1023	768
4	1025	1279	1024
5	1281	1535	1280
6	1537	1791	1536
7	1793	2047	1792
8	2049	2303	2048
9	2305	2559	2304
10	2561	2815	2560
11	2817	3071	2816
12	3073	3327	3072
13	3329	3583	3328
14	3585	3839	3584
15	3841	4000	3840
All Zones			4095

Tip: You've probably figured out that you never want to assign a **virtual device** number to an **actual device** in the system. If you assigned #1536 to a device, all the TV controllers in Zone 6 would respond every time you sent a command to that one device.

System Map

One of the key tasks for iC-Net integrators is to create a logical **System Map**, assigning device numbers to TV controllers so they fall into logical zones. The device mapping could be sorted by type or location; whichever suits the application.

iC-Net Zone	Zone	Room	Device
1	W 1 st Floor		256
		W151	257
		W152	258
		W153	259
		W154	260
2	W 2 nd Floor		512
		W251	513
		W252	514
		W253	515
		W254	516
3	E 1 st Floor		768
		E151	769
		E152	770
		E153	771
		E154	772
4	E 2 nd Floor		1024
		E251	1025
		E252	1024
		E253	1025
		E254	1026
5	Coffee Areas		1280
		G100	1281
		G150	1282
		G151	1283
6	Day Care		1536
		TV 1	1537
		TV 2	1538
7	Hallways		1792
		W1	1793
		W2	1794
		E1	1795
		E2	1796
8	Office		2048
		Admin	2049
		A/V Center	2050
All Zones	All		4095

Typical RF and ICC-Net Signal Flow

The diagram below shows the structure of a typical Contemporary Research media retrieval system. One of the key aspects for iCC-Net communication is to provide a forward and return (sub-channel) path for data.

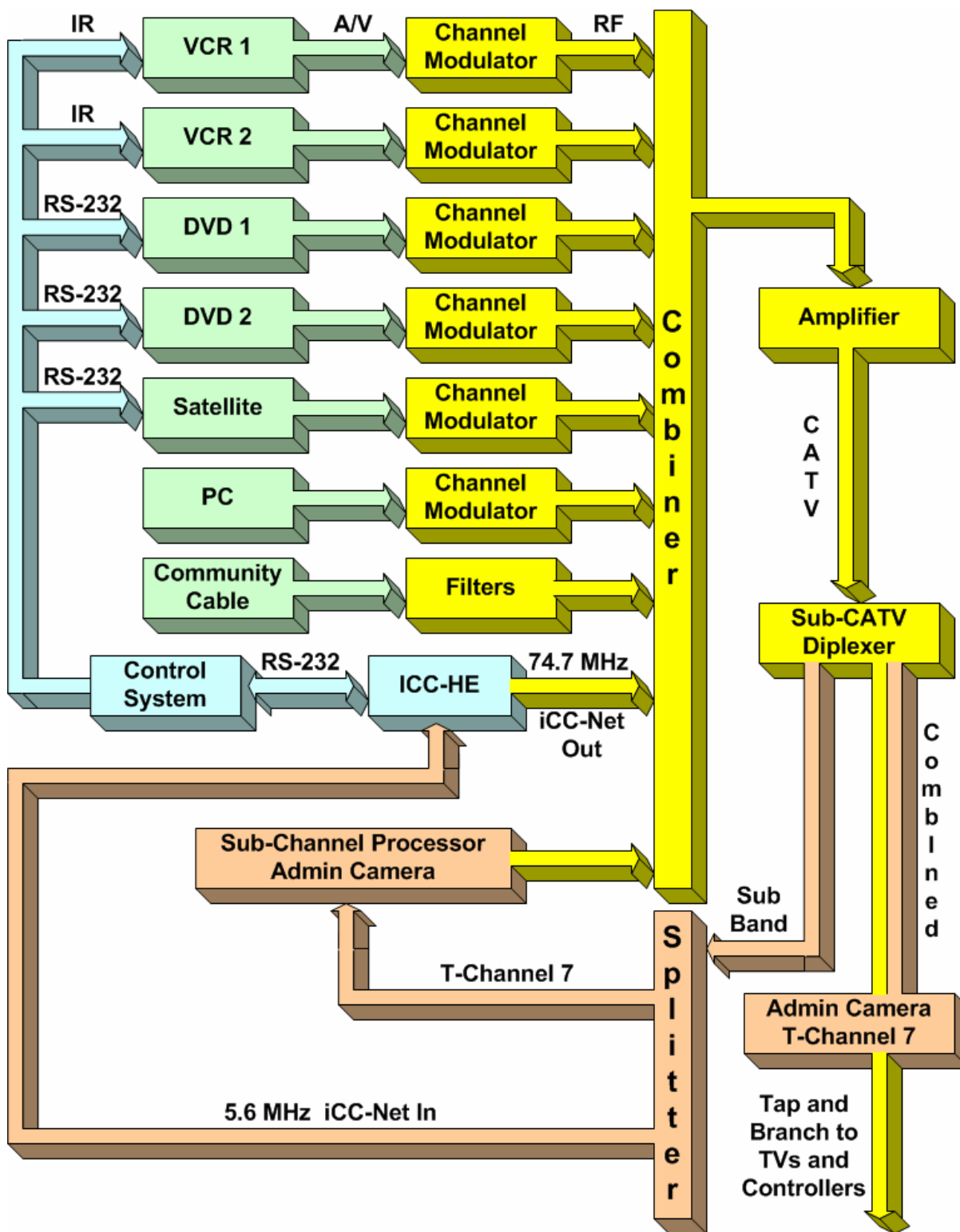

iCW-Net Wiring

Use Category 3 or Category 5 wire, 4 pair, unshielded, 24 AWG.

The iCC-HE and iCW-HE Head-End Network Controllers include three iCW-Net ports for twisted-pair wired networking. Control wiring can be home-run to ports or run in a star format, using punch-down blocks or RJ-45 "harmonicas" to distribute signals to multiple iCW-Net devices. Open wiring runs do not need termination.

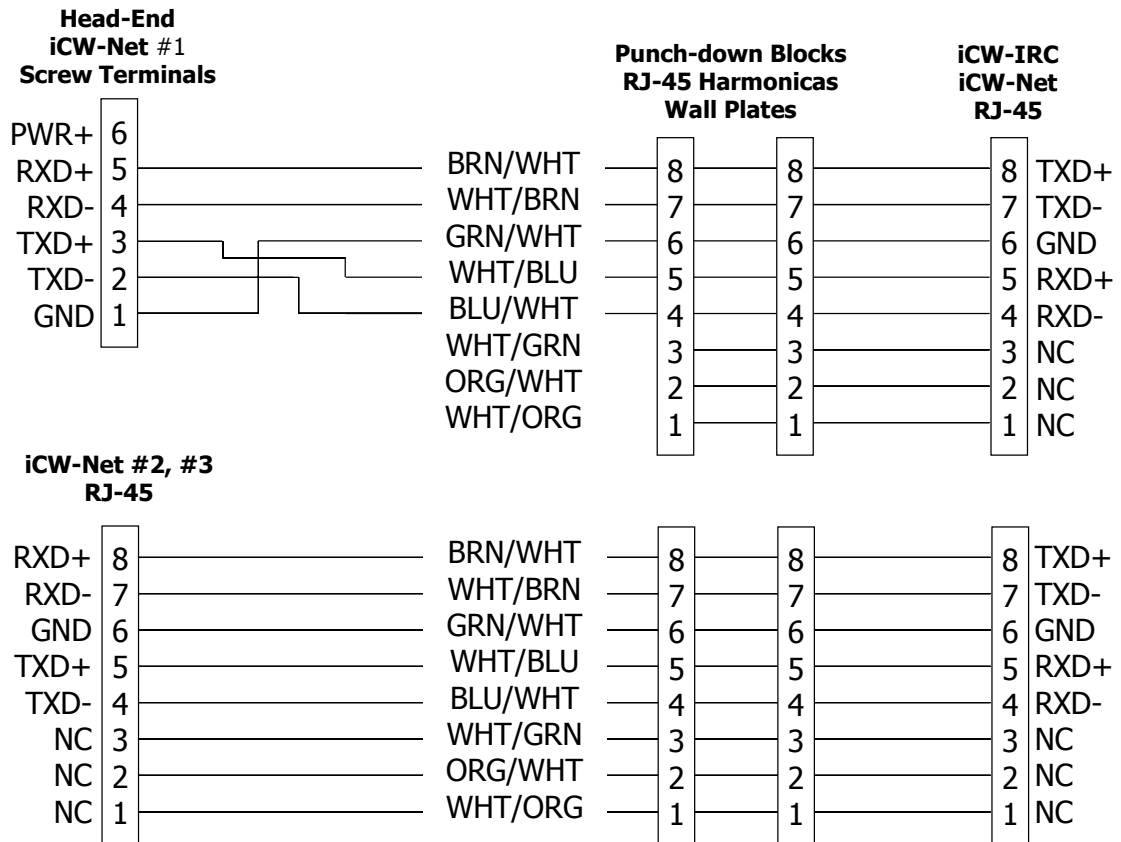

Mounting the IRC

In most cases, you'll mount the IRC directly to the TV, either below or above. Mounting below the TV is preferred, as it's usually the best location for IR reception from remotes, and helps to screen the internal IR sensors from stray ceiling-fixture IR.

Installers commonly use Velcro to secure the IRC to the TV. Others will use brackets, such as our optional RK2 Brackets to mount the IRC to the TV, as shown below. Some combine the two approaches, using Velcro during the initial phase of installation, then securing with brackets when testing and troubleshooting is completed.

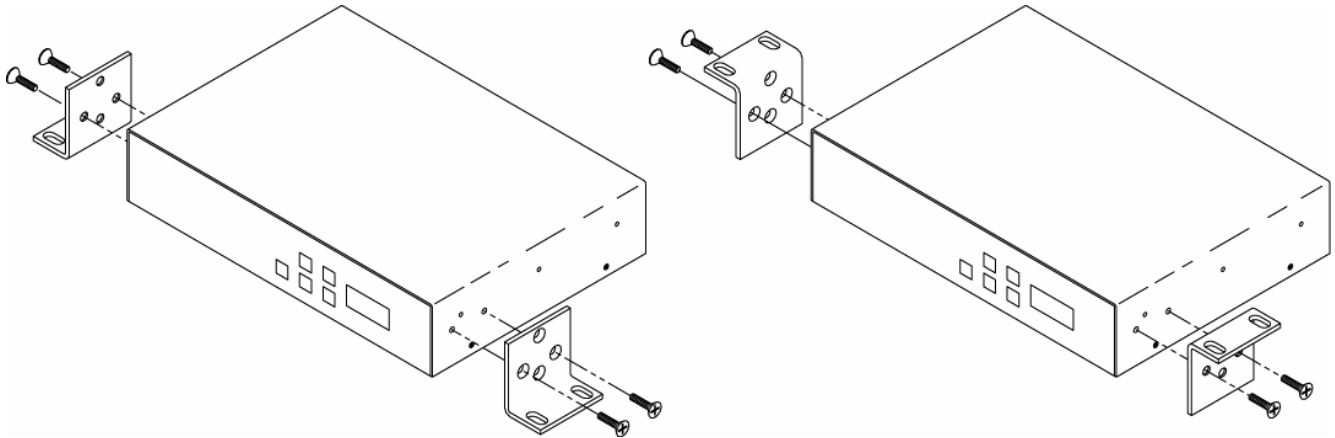

In all cases, it's best to mount the IRC near to the TV, monitor or video projector, simplifying wiring for A/V and control cables. If, for some reason, the IRC must be mounted in an equipment rack, you'll need an optional RK1 Rack Mount Kit. In addition, order the IRC with the external IR In input (a factory-installed option) and an optional IR-RX External IR Receiver.

Safety Instructions

Read before operating equipment.

1. **Cleaning** - Unplug this product from the wall outlet before cleaning. Do not use liquid cleaners or aerosol cleaners. Use a damp cloth for cleaning.
2. **Power Sources** - Use supplied or equivalent UL/CSA approved low voltage DC plug-in transformer.
3. **Outdoor Antenna Grounding** - If you connect an outside antenna or cable system to the product, be sure the antenna or cable system is grounded so as to provide some protection against voltage surges and built-up static charges. Section 810 of the National Electrical Code, ANSI/NFPA No. 70, provides information with respect to proper grounding of the mast and supporting structure, grounding of the lead-in wire to an antenna discharge unit, size of grounding conductors, location of antenna discharge unit, connection to grounding electrodes, and requirements for the grounding electrode.
4. **Lightning** - Avoid installation or reconfiguration of wiring during lightning activity.
5. **Power Lines** - Do not locate an outside antenna system near overhead power lines or other electric light or power circuits or where it can fall into such power lines or circuits. When installing an outside antenna system, refrain from touching such power lines or circuits, as contact with them might be fatal.
6. **Overloading** - Do not overload wall outlets and extension cords as this can result in a risk of fire or electric shock.
7. **Object and Liquid Entry** - Never push objects of any kind into this product through openings as they may touch dangerous voltage points or short out parts, resulting in a fire or electric shock. Never spill liquid of any kind on the product.
8. **Servicing** - Do not attempt to service this product yourself as opening or removing covers may expose you to dangerous voltage or other hazards. Refer all servicing to qualified service personnel.
9. **Damage Requiring Service** - Unplug this product from the wall outlet and refer servicing to qualified service personnel under the following conditions:
 - When the power supply cord or plug is damaged.
 - If liquid spills or objects fall into the product.
 - If the product is exposed to rain or water.
 - If the product does not operate normally by following the operating instructions. Adjust only those controls that are covered by the operating instructions. An improper adjustment of other controls may result in damage and will often require extensive work by a qualified technician to restore the product to its normal operation.
 - If the video product is dropped or the cabinet is damaged.
 - When the video product exhibits a distinct change in performance, this indicates a need for service.

*** Note to CATV system installer:** This reminder is provided to call CATV system installer's attention to Article 820-40 of the National Electrical Code (Section 54 of Canadian Electrical Code, Part I), that provides guidelines for proper grounding and, in particular, specifies that the cable ground shall be connected to the grounding system of the building as close to the point of cable entry as possible.

Limited Warranty and Disclaimer

Contemporary Research Corporation (CR) warrants this product to be free from defects in material and workmanship under normal use for a period of two years from the date of purchase from CR. Should such a defect occur CR will repair or replace, at their option, the defective product at no cost for parts or labor.

This warranty extends to product purchased directly from CR or an Authorized CR Dealer. Consumers should inquire from selling dealer as to the nature and extent of the dealer's warranty, if any.

All warranty claims must be shipped pre-paid to the factory. Call or fax to obtain a Return Material Authorization (RMA) number.

CR is not liable for any damages caused by any of its products or for the failure of any products to perform, including any lost profits, lost savings, incidental damages, or consequential damages. CR is not responsible for any claim made by a third party or made for you by a third party. This limitation of liability applies whether damages are sought, or a claim is made, under this warranty or as a tort claim (including negligence and strict product liability), a contract claim, or any other claim. This limitation of liability cannot be waived or amended by any person. This limitation of liability will be effective even if CR or an authorized representative of CR has been advised of the possibility of any such damages.

Some states do not allow a limitation of how long an implied warranty lasts. Some states do not allow the limitation or exclusion of incidental or consequential damages for consumer products. In such states, the limitation or exclusion of the Limited Warranty may not apply to you. This Limited Warranty gives you specific legal rights. You may also have other rights that may vary from state to state. You are advised to consult applicable state laws for a full determination of your rights.

Except as expressly set forth in this Limited Warranty, CR makes no other warranties, expressed or implied, including any implied warranties of merchantability or fitness for a particular purpose. CR expressly disclaims all warranties not stated in this Limited Warranty. Any implied warranties that may be imposed by law are limited to the terms of this Limited Warranty.



Free Manuals Download Website

<http://myh66.com>

<http://usermanuals.us>

<http://www.somanuals.com>

<http://www.4manuals.cc>

<http://www.manual-lib.com>

<http://www.404manual.com>

<http://www.luxmanual.com>

<http://aubethermostatmanual.com>

Golf course search by state

<http://golfingnear.com>

Email search by domain

<http://emailbydomain.com>

Auto manuals search

<http://auto.somanuals.com>

TV manuals search

<http://tv.somanuals.com>