



---

# CONTINUOUS FLOW ICEMAKER

WCC1401-A/WCF1411-A Series

## Service Manual

**Release Date: October 26, 2006**

**Publication Number: 630460324SER**

**Revision Date: N/A**

**Revision: A**

**Visit the IMI Cornelius web site at [www.cornelius.com](http://www.cornelius.com) for all your Literature needs.**



---

# CONTINUOUS FLOW ICEMAKER SERVICE MANUAL

The products, technical information, and instructions contained in this manual are subject to change without notice. These instructions are not intended to cover all details or variations of the equipment, nor to provide for every possible contingency in the installation, operation or maintenance of this equipment. This manual assumes that the person(s) working on the equipment have been trained and are skilled in working with electrical, plumbing, pneumatic, and mechanical equipment. It is assumed that appropriate safety precautions are taken and that all local safety and construction requirements are being met, in addition to the information contained in this manual.

To inquire about current revisions of this and other documentation or for assistance with any Cornelius product contact:

**[www.cornelius.com](http://www.cornelius.com)  
800-238-3600**

Trademarks and copyrights:

Aurora, Cornelius, Decade, Hydro Boost, Sitco, Spirit, UF-1, Vanguard, Venture, Olympus, and Vista are registered trademarks of IMI Cornelius Inc.

Optifill trademark is pending.

This document contains proprietary information and it may not be reproduced in any way without permission from Cornelius.

Printed in U.S.A.

Copyright © 2006, All Rights Reserved, IMI Cornelius, Inc.



# TABLE OF CONTENTS

<b>Safety</b> .....	<b>1</b>
Safety Instructions .....	1
Read and Follow all Safety Instructions .....	1
Recognize Safety Alerts .....	1
Different Types of Alerts .....	1
Safety Tips .....	1
Qualified Service Personnel .....	1
Shipping And Storage .....	1
<b>General Description</b> .....	<b>2</b>
Specification Chart .....	2
<b>Electrical</b> .....	<b>4</b>
<b>Refrigeration Schematic</b> .....	<b>5</b>
<b>Cleaning and Sanitizing</b> .....	<b>6</b>
Icemaker Cleaning and Sanitizing Procedures .....	6
Maintenance .....	6
Monthly .....	6
Quarterly .....	6
Semi-Annually .....	7
<b>Refrigeration System</b> .....	<b>8</b>
Refrigeration System Adjustments .....	8
Pumpdown Cycle .....	8
Expansion Valve .....	8
<b>Water Level Control</b> .....	<b>9</b>
How Water Level Control Works .....	9
Purpose of Water Level Control .....	9
To Replace Water Level Control .....	9
To Replace Water Level Safety Switch .....	9
Bin Control .....	10
Gearmotor .....	10
Motor Check .....	12
Start Relay .....	12
To Replace Gearmotor Assembly .....	12
Auger and Extruding Head Removal .....	13
Installation and Shaft Seal Replacement .....	13
Upper Nut and Bearing Assembly .....	13
To Replace Bearing .....	13
Electrical Checkout .....	14
Overload Check .....	14
Compressor Check .....	14
Capacitor Check .....	14
Safety Controls .....	14
<b>Troubleshooting</b> .....	<b>16</b>



# SAFETY

## SAFETY INSTRUCTIONS

### Read and Follow all Safety Instructions

Read and follow all safety instructions in this manual and on the machine (decals, labels, and laminated cards).

Read and understand all applicable OSHA (Occupation Safety and Health Administration) safety regulations before operating the machine.

### Recognize Safety Alerts



This is the safety alert symbol. When you see it in this manual or on the machine be alert to the potential of personal injury or damage to the machine.

### Different Types of Alerts

There are 3 types of safety alerts:



**DANGER** — Indicates an immediate hazardous situation which if not avoided **WILL** result in serious injury, death, or equipment damage.



**WARNING** — Indicates a potentially hazardous situation which, if not avoided, **COULD** result in serious injury, death, or equipment damage.



**CAUTION** — Indicates a potentially hazardous situation which, if not avoided, **MAY** result in minor or moderate injury or equipment damage.

### SAFETY TIPS

- Carefully read all safety messages in this manual and safety signs on the machine.
- Keep safety signs in good condition and replace missing or damaged safety signs.
- Learn how to operate the machine and how to use the controls properly.
- Do not let anyone operate the machine without proper training. This appliance is not intended for use by very young children or infirm persons without supervision. Young children should be supervised to ensure that they do not play with the appliance.
- Keep your machine in proper working condition and do not allow unauthorized modifications to the machine.

### QUALIFIED SERVICE PERSONNEL



**CAUTION** — Only trained and certified electrical, plumbing and refrigeration technicians should service this unit. **ALL WIRING AND PLUMBING MUST CONFORM TO NATIONAL AND LOCAL CODES.**

### SHIPPING AND STORAGE



**CAUTION** — Before shipping, storing, or relocating the Unit, syrup systems must be sanitized and all sanitizing solution must be purged from the syrup systems. All liquids, after sanitizing, must be purged from the unit. A freezing ambient environment will cause residual sanitizing solution or water remaining inside the Unit to freeze resulting in damage to the internal components.

# GENERAL DESCRIPTION

This section gives the Unit description, theory of operation, and design data for continuous flow icemaker series WCC1401-A.

## SPECIFICATION CHART

Models	Description	VAC	HZ	PH	Wire	Comp. RLA	Fan Amps	GRMTR Amps	Refrigerant		Circuit Fuse
									Oz.	Type	
WCC1401-A	Ice Maker	208/230	60	1	2	12.2	1.2 (2)	2.0 (2)	35	404A	20

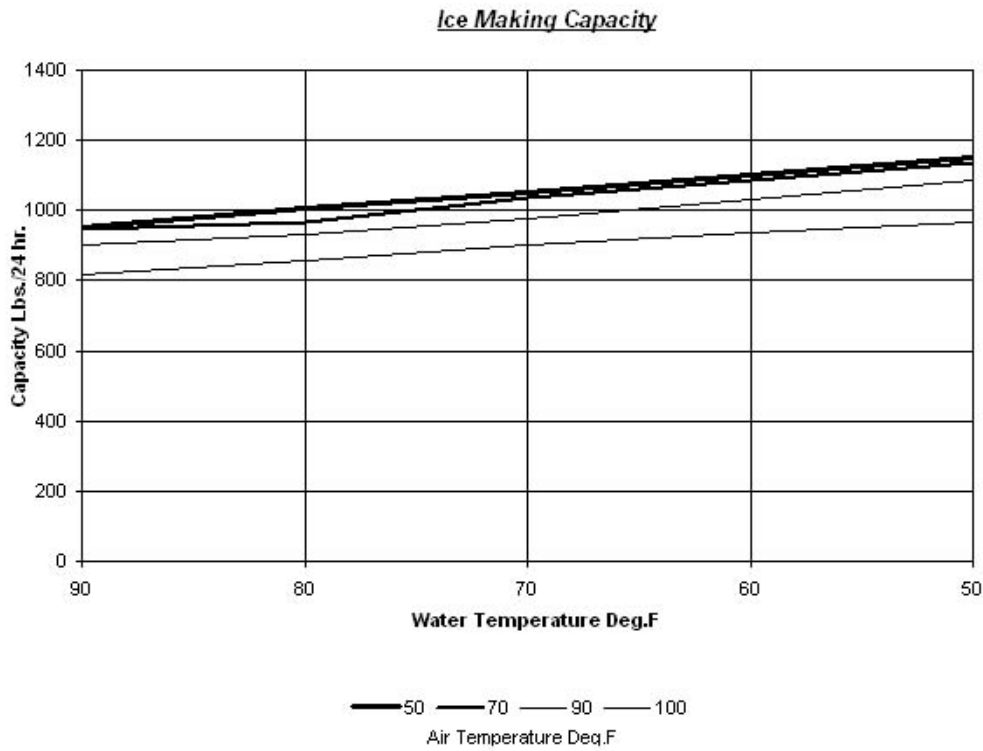
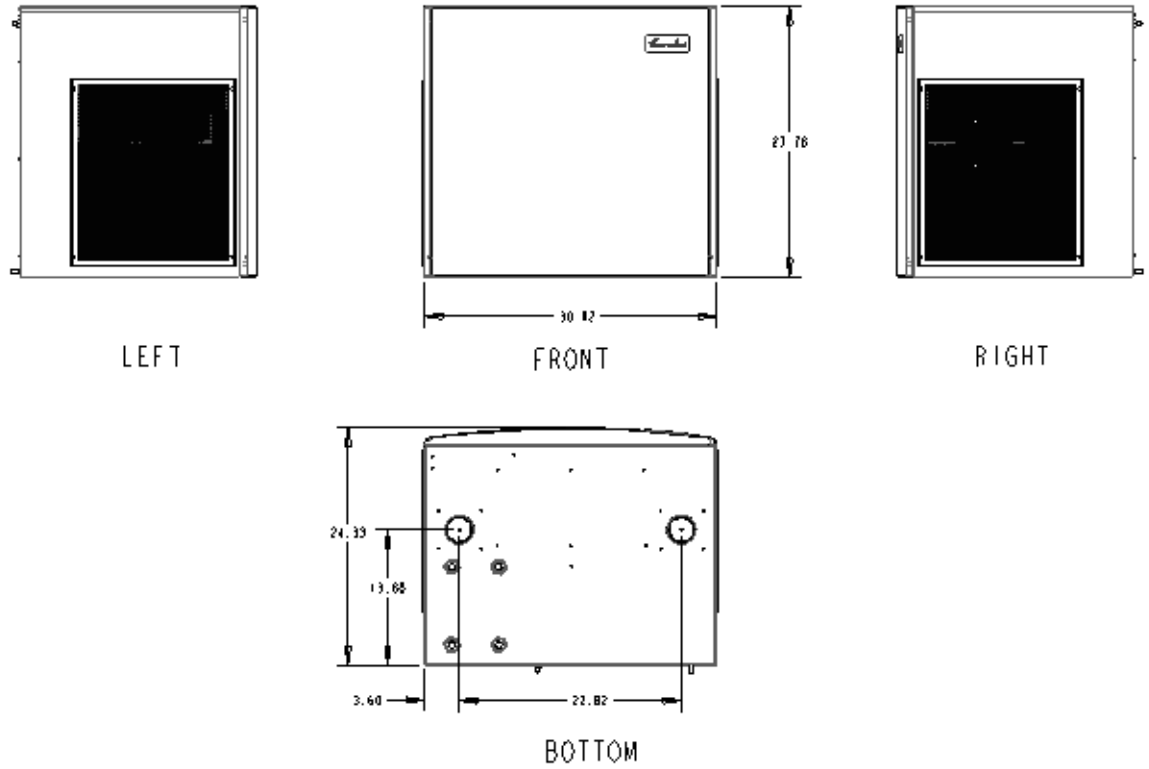
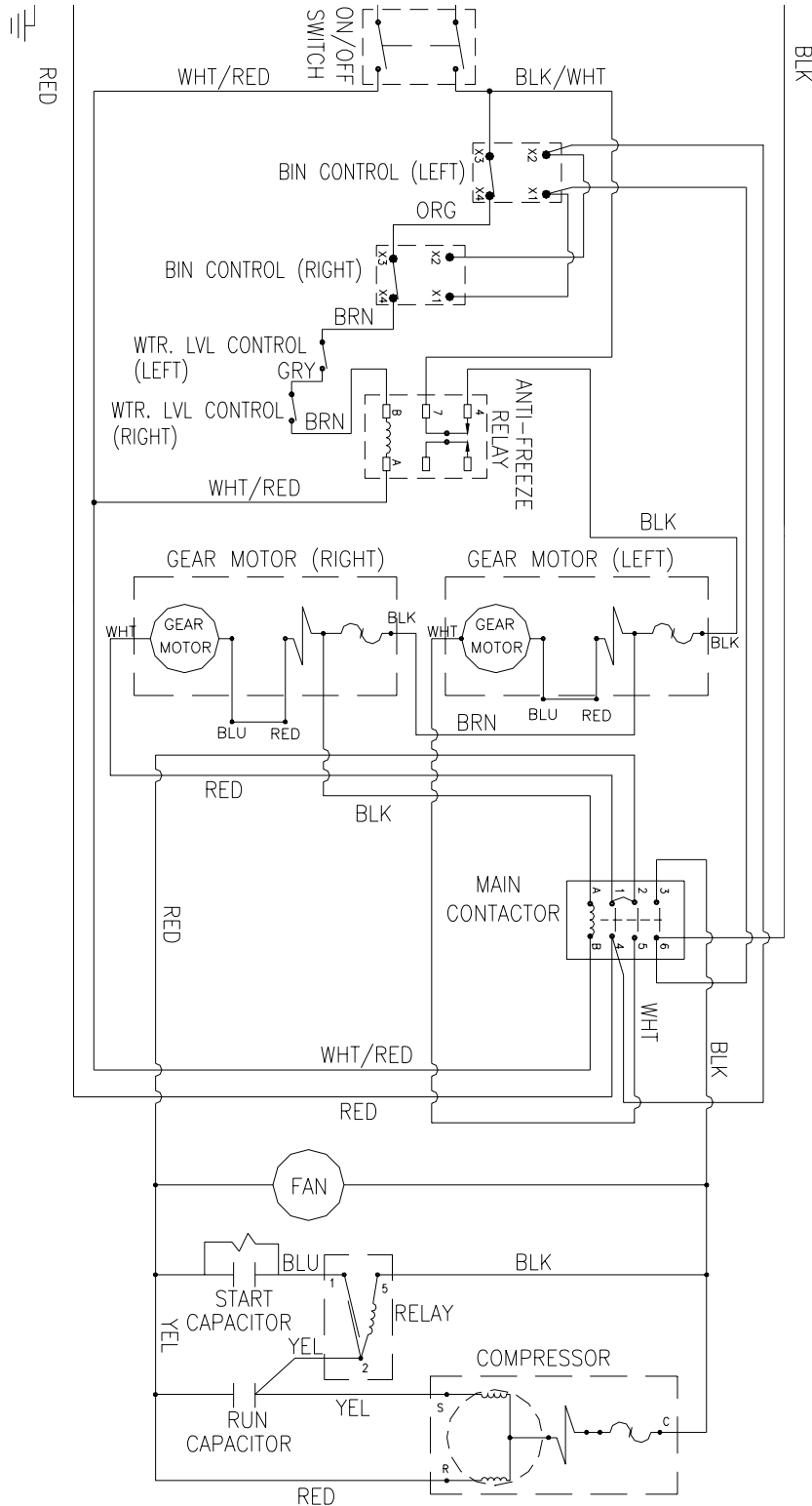

FIGURE 1



**FIGURE 2. Series WCC1401-A/WCF1411-A Dimension Drawing**

# ELECTRICAL



**FIGURE 3. Schematic WCC1401-A/WCF1411-A**



# REFRIGERATION SCHEMATIC

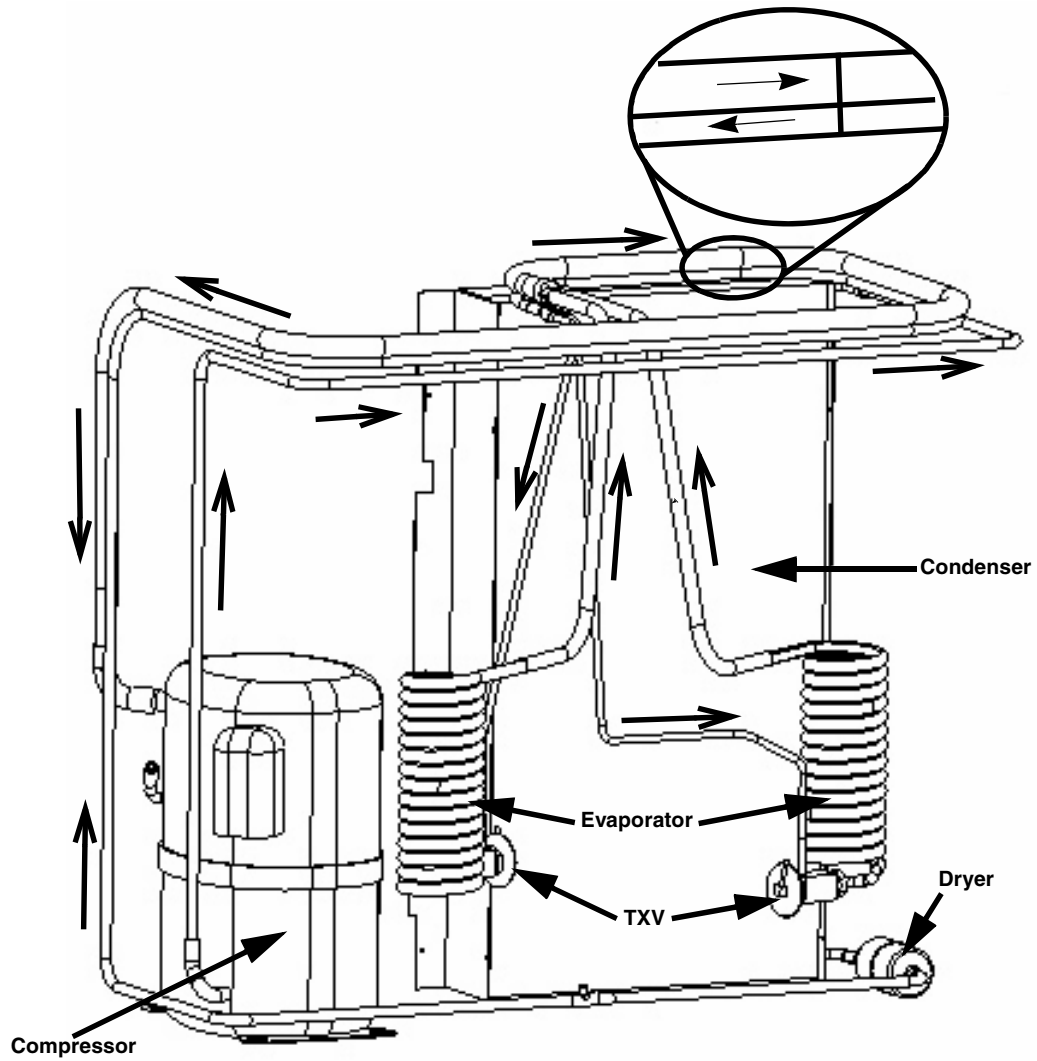

FIGURE 4. WCC1401-A

# CLEANING AND SANITIZING

## ICEMAKER CLEANING AND SANITIZING PROCEDURES

Do not use any of the ice made during cleaning operations.

Clean and sanitize ice storage area when cleaning icemaker.

1. Turn off machine.
2. Shut off water supply
3. Remove ice from storage bin.
4. Mix approved cleaner (4 gallons as directed). **Recommended cleaner:** Calgon Nickel-Safe, ice machine cleaner. **Mixture:** 3 ounces per gallon of water.
5. Clean auger/diverter assembly and ice transition/drop tube in a sink using cleaner mixture and reinstall in icemaker. Using cleaner, wipe down dispense tray.
6. Turn machine on and add cleaner solution to water level control, 2 gallons to each control.
7. Turn on water supply and run machine for 15 minutes.
8. Turn off machine and remove all ice. Turn off water and drain water.
9. Sanitize using household liquid bleach (299 ppm chlorine). **Mixture:** ½ fluid ounce per gallon room temperature water. 2 minute exposure time.
10. Sanitize auger/diverter assembly and ice transition/drop tube in a sink using sanitizing solution and reinstall in icemaker. Using sanitizer, wipe down dispense tray.
11. Fill icemaker with sanitizer by slowly pouring solution into water feed reservoir until full. Solution will drain through overflow tube. Turn on water. Run the icemaker for 15 minutes. Turn off ice machine and remove all ice.
12. If icemaker is used in conjunction with ice dispenser or storage bin, follow manufacturer's recommended cleaning instructions at this time.

## MAINTENANCE

Preventive maintenance can increase the trouble free life of your icemaker. Many authorized service agencies offer service contracts for your icemaker. Contact your local distributor for further information.

### Monthly

1. Clean the condenser. Use a brush, vacuum cleaner or blower from inside with air or CO2 gas.
2. Inspect water feed reservoir at least once a month until a definite pattern for cleaning and sanitizing has been established.

### Quarterly

This is the maximum period of time between cleaning and sanitizing the icemaker. In addition to recommended monthly procedure, and if a more frequent cleaning and sanitizing pattern has not been established, unit must be cleaned and sanitized.

## Semi-Annually

Semi-Annually in addition to all previously established service procedures perform the following:

1. Check for water leaks in tube connections, water fittings and lower icemaker water seal.
2. Check drain tubes for clogs and aged tubes. Replace if tubes are stained or brittle.
3. Check for signs of condensation. Clean where necessary and replace insulation properly.
4. Check safety circuits for proper operation.
5. Check refrigeration system.
6. Check unit for abnormal noise. Tighten machine and cabinet screws if necessary.
7. Check white upper bearing on auger assembly. If bearings are less than 1/16" thick, replace.

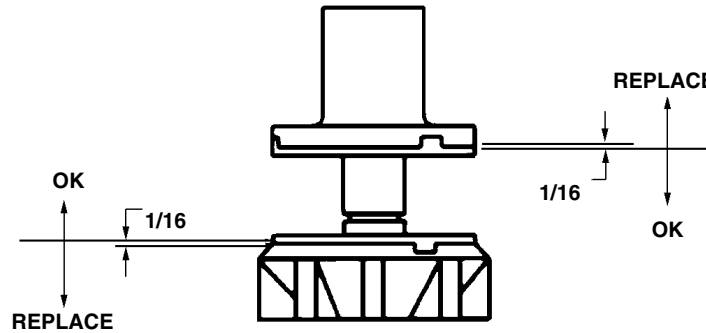

FIGURE 5. UPPER NUT AND BEARING ASSEMBLY

# REFRIGERATION SYSTEM

		Suction Pressure +/- 2 lb. Water Temperature		
		50°	70°	90°
AIR TEMP.	50°	18	18	18
	60°	20	20	20
	70°	20	20	20
	80°	21	21	21
	90°	23	23	23
	105°	27	27	27

		Discharge Pressure +/- 10 lbs. Water Temperature		
		50°	70°	90°
AIR TEMP.	50°	213	213	213
	60°	220	220	220
	70°	225	225	226
	80°	230	230	231
	90°	251	251	252
	105°	302	302	303

## REFRIGERATION SYSTEM ADJUSTMENTS

A complete understanding of the icemaker and hermetic refrigeration system is necessary before any adjustments are made. The refrigeration technician must use high and low side pressure readings, water and air temperatures, plus general conditions of cleanliness to assess the refrigeration system status when making any adjustments.

All icemaker products are tested and adjusted at the factory prior to shipment where the ambient temperature ranges from 650F to 900F, depending on the season of the year.

Whenever a new icemaker is initially installed and started-up, it is imperative that the start-up operator make the following checks and readjustments for local conditions.

## PUMPDOWN CYCLE

The Series1400 unit is a split system. The icemaker consists of two gearmotor/evaporator assemblies and a liquid line solenoid. The condensing unit consists of a compressor, condenser, fan motor and receiver. The icemaker is designed for indoor use only. The condensing unit is designed for outdoor use. The two units are connected with a precharged line kit.

The system operates on a pump down cycle. When the bin thermostat senses ice it opens the circuit to the liquid line solenoid. The liquid line solenoid closes and stops the flow of refrigerant to the evaporators. This causes the suction pressure to drop. The condensing unit is shut off when the suction pressure drops below 5 psig. The low-pressure control should be adjusted to open between 0-5 psig and close between 15-20 psig. Note: there is no electrical connection between the two units.

## EXPANSION VALVE

You will find a thermal expansion valve on icemakers, which is used to control the amount of refrigerant flowing through the evaporator. Improperly installed or defective expansion valves may cause low production, soft ice, squeaking from evaporator and excessive load inside evaporator.

By using general refrigeration trouble shooting along with the pressure charts, you can easily determine whether or not the expansion valve is working properly.

**NOTE: Units with thermostatic expansion valve, the valve is located on bottom refrigerant line. Sensing bulb is located on top refrigerant line.**



Very high discharge pressure is present in system. Quick disconnects on your gages will minimize Danger and loss of refrigerant. Comply with federal regulations for reclaiming refrigerant.

# WATER LEVEL CONTROL

## HOW WATER LEVEL CONTROL WORKS

When water is introduced through the inlet fitting the float rises, the float pushes against a lever that in turn, forces the poppet assembly against the inlet fitting valve seat that seals the water off. See Figure 1 (page 7). Before the water inlet is sealed, the safety switch is operated. In the event of a water failure the float would drop down and operate the safety switch to shut off the machine.

If water level control will not shut off and seal at level as indicated, be sure inlet pressure does not exceed recommended factory operating range.

Under ordinary circumstances adjustment should not be necessary providing it was properly adjusted when unit was installed or relocated. If however, the control becomes inoperative, repair or replace. See Start-up Adjustment in the installation manual.

## PURPOSE OF WATER LEVEL CONTROL

1. To automatically maintain proper water level in the evaporator when the unit is running and making ice.
2. A safety switch is operated in the event of an interruption in water supply. The switch shuts off the electrical power to the icemaker and its refrigeration system. Switch will reset as soon as cause of water failure has been corrected and proper water level in icemaker has again been reached.
3. The transparent bowl not only provides a visible check of water level, but also is a good guide to the internal conditions which exist within the icemaker assembly itself. (See cleaning procedure.)

## TO REPLACE WATER LEVEL CONTROL

1. Shut off the water supply. Shut off the main power switch or unplug the ice dispenser from electrical outlet.
2. Remove the flexible tubing from bottom of water level control and drain water from water level control and evaporator.
3. Remove flexible tubing at bottom of water level bowl connected to the overflow.
4. Hold water inlet fitting with proper tool to prevent it from rotating when disconnecting the water inlet.
5. Remove wing nut holding water control to its mounting bracket. Control can be removed by lifting straight up.

## TO REPLACE WATER LEVEL SAFETY SWITCH

1. Shut off main power switch or unplug the ice dispenser from electrical outlet.
2. Unplug Molex connector connecting switch to electrical box.
3. Remove the 2 screws anchoring the water level safety switch to the bottom of the water level control mounting bracket.

## BIN CONTROL

The type of bin control used on all WCC and WCF Models is an electronic control. The control is supplied with power to terminals X1 and X2. Terminals X3 and X4 are a normally closed switch which open when the thermostat sensor bulb senses ice. The WCC1401-A/WCF1401-A uses 2 controls, terminals X1 and X2 are connected in parallel and terminals X3 and X4 are connected in series.

The sensing bulbs are located in a 5/16" stainless steel tube which hangs from the dispense tray covers down through the center of the drop tube.

To test the switch, start the icemaker and block the outlet tube, about ½ full the icemaker should shut off. When the tube is cleared the icemaker should restart within 5 min.

The Bin controls are in electrical series with the coil on the antifreeze relay along with the low water safety.

The controls are held in place inside the electrical box by 4 screws. The control bulbs are in the drop tubes. They can be removed by pulling the cable located on the top of the dispense tray cover. When replacing the sensor make sure the bulb is inserted to the bottom of the thermostat well.

## GEARMOTOR

The gearmotors are equipped with a start relay and a manual reset overload.

When current is applied, the relay energizes and completes the circuit to the start winding. The motor reaches a predetermined speed and the relay drops out, disconnecting the start winding. The run winding remains in the circuit as long as current is applied.

The purpose of the overload is to automatically shut off the motor in the event of a mechanical bind of the transmission, an overload condition within the evaporator or an electrical malfunction. It does this by sensing amperage draw. If the motor stalls the start relay would energize and stay energized. The amperage would surge 5 to 6 times greater than normal draw. In this event the overload would shut off the transmission in 4 to 8 seconds.

If the motor is subjected to abnormal load, but does not reach stall condition, the overload will react, but over a greater period of time. The reaction time depends upon the amperage to which it is subjected.

The overloads to each motor are connected in series; if either overload trips both gearmotors and the liquid line solenoid are shut off.

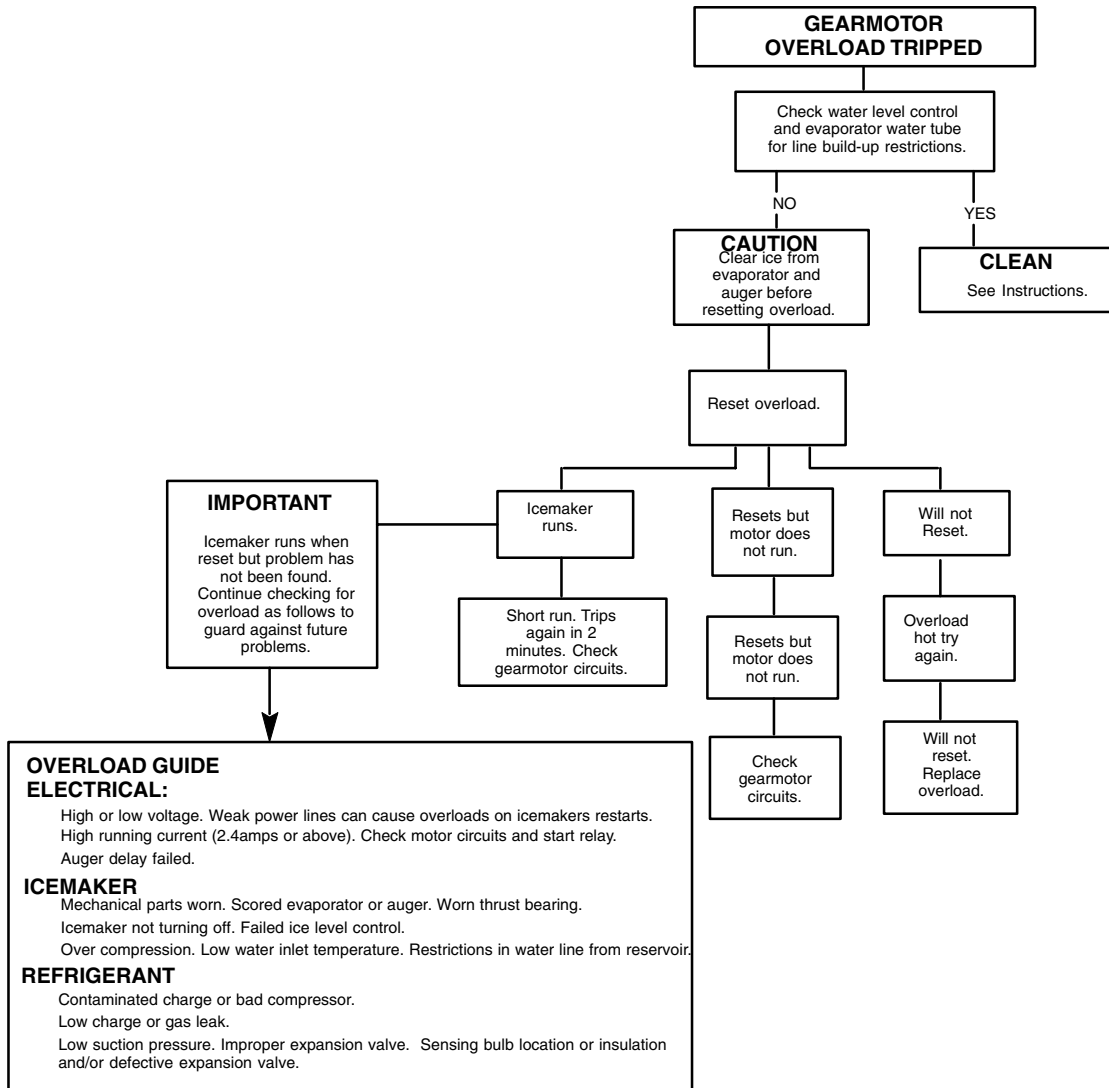

## MOTOR CHECK

The resistance readings on the winding will be between 5 to 25 ohms. A meter capable of these low readings must be used. The start relay cover must be removed.

If no continuity on start or run winding test, replace gearmotor. If continuity on grounded motor test, replace gearmotor.

## START RELAY

1. Check between "2" and "4" on relay (with relay unplugged). If there is continuity replace the relay, as the relay contacts should be open.
2. Check between "3" and "4" on relay, if no continuity replace the relay.

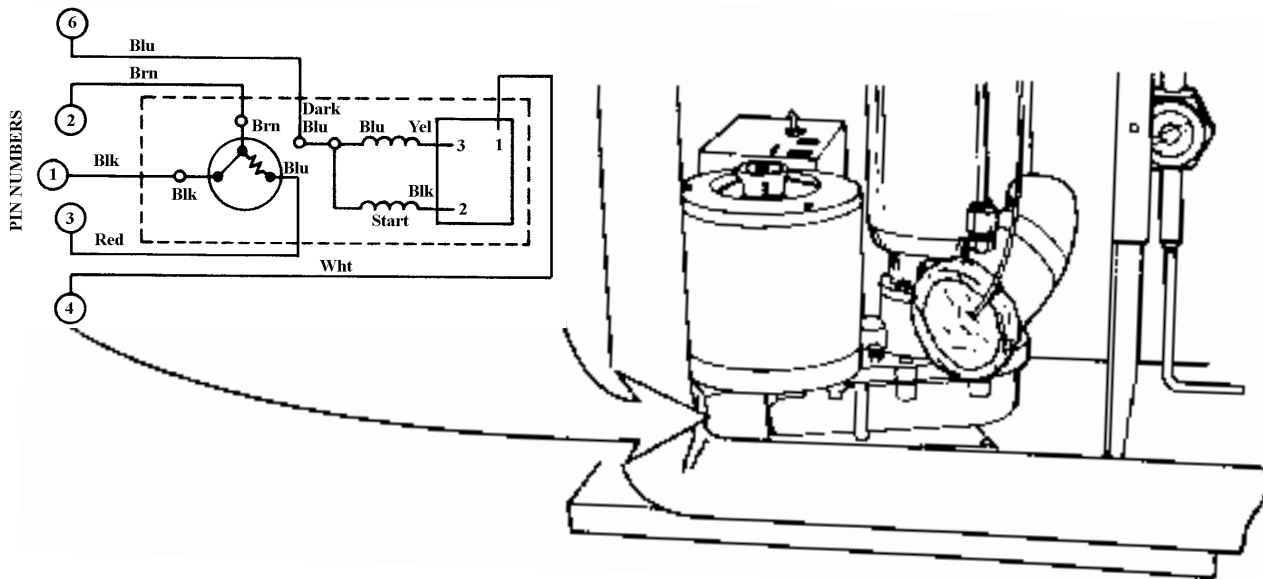

FIGURE 6. GEARMOTOR ASSEMBLY

## TO REPLACE GEARMOTOR ASSEMBLY

1. Disconnect the icemaker from the electrical power source.
2. Disconnect the transmission cable from the electrical box.
3. Remove the 4 hex head bolts securing the evaporator to the top of the transmission.
4. Remove the 4 bolt's holding the transmission and bracket to frame base, while supporting the weight of the evaporator. Remove the transmission from the unit.
5. When replacing the transmission, it may be necessary to rotate the auger back and forth to align the motor shaft and auger.

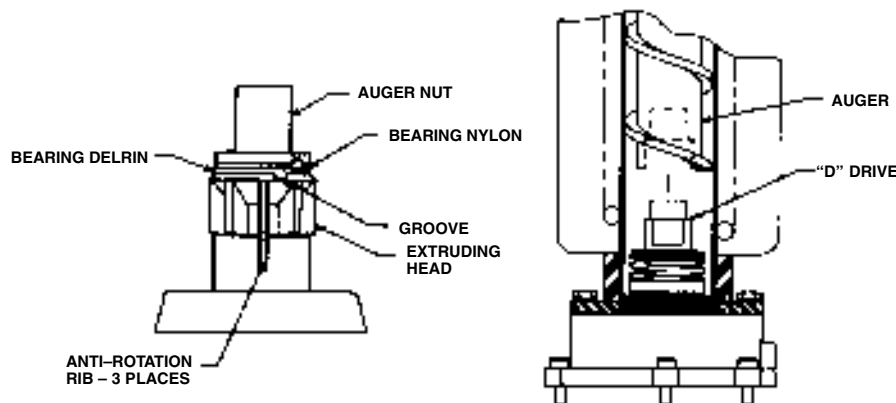

FIGURE 7. AUGER AND EXTRUDING HEAD REMOVAL



## AUGER AND EXTRUDING HEAD REMOVAL

1. Disconnect unit from power supply.
2. Remove storage container cover and put aside.
3. Turn off water supply to icemaker.
4. After ice has melted from head take hold of the auger nut and lift straight up to disengage from icemaker.
5. When replacing the auger assembly, make certain that both the auger engages the output shaft drive and the extruding head ribs engage the evaporator tube.

## INSTALLATION AND SHAFT SEAL REPLACEMENT

1. Place shaft seal locator seat and shaft seal mount over gearmotor output shaft and push down until shaft seal seat and shaft seal mount rest flush on top of gearmotor.
2. Place rubber coated ceramic seal (important: ceramic face up) over output shaft and push down until seal nest in recess of shaft seal mount. (lubricate rubber on ceramic seal with rubber lubricant).
3. Place shaft seal with carbon face down (spring up) over output shaft and push (gently) downward until seal rests on carbon face of the output shaft seal.
4. Place flat washer over output shaft and let rest on the output shaft seal. Push down on the washer compressing the spring on the output shaft seal. While holding the seals (down) in place slide the E-ring into the groove on the output shaft

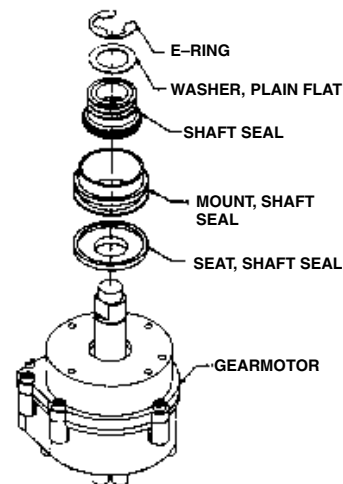

FIGURE 8. SHAFT SEAL 700 AND 1000

## UPPER NUT AND BEARING ASSEMBLY

The upper white bearing located on top of the auger is used to absorb the force between the auger and extruding head.

**NOTE: The bearings are 3/32 thick. When they wear below 1/16 they should be replaced. Bearings to be inspected for wear during quarterly maintenance.**

### To Replace Bearing

1. Disconnect unit from electric power.
2. Remove top panels.
3. Remove Dispense Tray Cover.
4. Use an open end wrench on auger nut connected to bearing and turn counterclockwise to remove assembly.
5. Remove worn bearings. Replace with new bearings and then reinstall assembly.

**NOTE: If auger turns with nut, remove cover on top of gearmotor stator and hold motor while loosening nut.**

## ELECTRICAL CHECKOUT

1. Be sure the unit is disconnected from the power source. Remove the compressor electrical box cover. Check for obvious damage and loose wires.
2. Disconnect the fan motor leads. Since capacitors store energy, short the capacitor with a screwdriver. This will prevent shocks.
3. Disconnect the compressor terminal wires.

## OVERLOAD CHECK

Using a volt-ohmmeter check the continuity across the overload, contact #1 and #3. If none, wait for unit to cool down and try again. If still no continuity, the overload protector is defective and should be replaced.



FIGURE 9. OVERLOAD CHECK

## COMPRESSOR CHECK

The resistance readings on the windings will be between 0.25 to 10.00 ohms, a meter capable of these low readings must be used.

1. Check between "C" and "R." Replace the compressor if there is no continuity as the run windings are open.
2. Check between "C" and "S." Replace the compressor if there is no continuity as the start windings are open.
3. Check between "C" and "R" or "S" and the shell of the compressor. If there is continuity, replace the compressor as the motor is grounded.
4. Check between screw terminal on the overload and "C" on the compressor. Check and repair the lead or connections if there is no continuity.

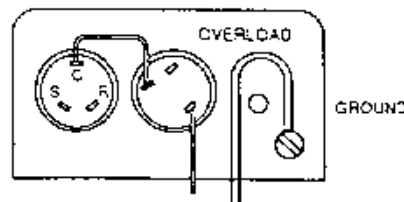

FIGURE 10. COMPRESSOR CHECK

## CAPACITOR CHECK

1. Check or replace start capacitor, disconnect bleed resistor before checking for shorted capacitor.
2. Check or replace run capacitor (if supplied) check for shorted capacitor or either terminal grounded to case.

## SAFETY CONTROLS

Your icemaker unit has several safety and control devices incorporated into its design.



**WARNING:** None of the below described devices should ever be "bypassed" to allow the unit to function.

The safety and control system shut-off devices are:

1. Low water shut off reed switch located in icemaker float assembly. (Automatic reset type.)
2. Gearmotor thermal overload, manual reset type (red button on motor).
3. Compressor thermal overload, automatic reset type.
4. Anti-freeze relay and associated circuit. See wiring diagrams.
5. Main service switch located on top of the control box.
6. Bin Control.
7. High pressure cut out (water cooled only).

**GUIDE TO GOOD ICE**

**CUSTOMER COMMENTS**

**CHECK ICEMAKER LOCATION CONDITIONS FIRST**

**CHECK ICE MAKER**

"It runs but the ice is too soft."

"The icemaker is not producing enough ice."

"The ice is too wet."



Proper air flow for condensing system.

Location too close to high units such as coffee urns, deep fryers, grills, etc.

Supply water conditions

Water too warm (above 90°F).

Water artificially softened above 262 ppm sodium chloride.

Normal water supply too high in total dissolved solids (above 500 PPM).

Use gauges for checking suction and head pressures. See manual for correct reading and conditions. Check frost line and sight glass.

Check water level for proper adjustment and restrictions. See Manual.

Check evaporator assembly for worn parts, bearings, scored evaporator and auger, bad expansion valve, etc.

"It makes too much noise."

(With this comment the ice is usually extremely hard and larger than normal.)



Over Compression

Check to see if noise objection is normal fan and air flow noise.

Supply water conditions.

Water too cold (below 50°F). (Possibly running from pre-cooler.)

Obstructions partially blocking ice exit from top of evaporator.

Check fan and fan shroud.

Check for loose parts and screws rattling.

Check evaporator assembly for worn parts, bearings, scored evaporator and auger, bad expansion valve, etc.

# TROUBLESHOOTING

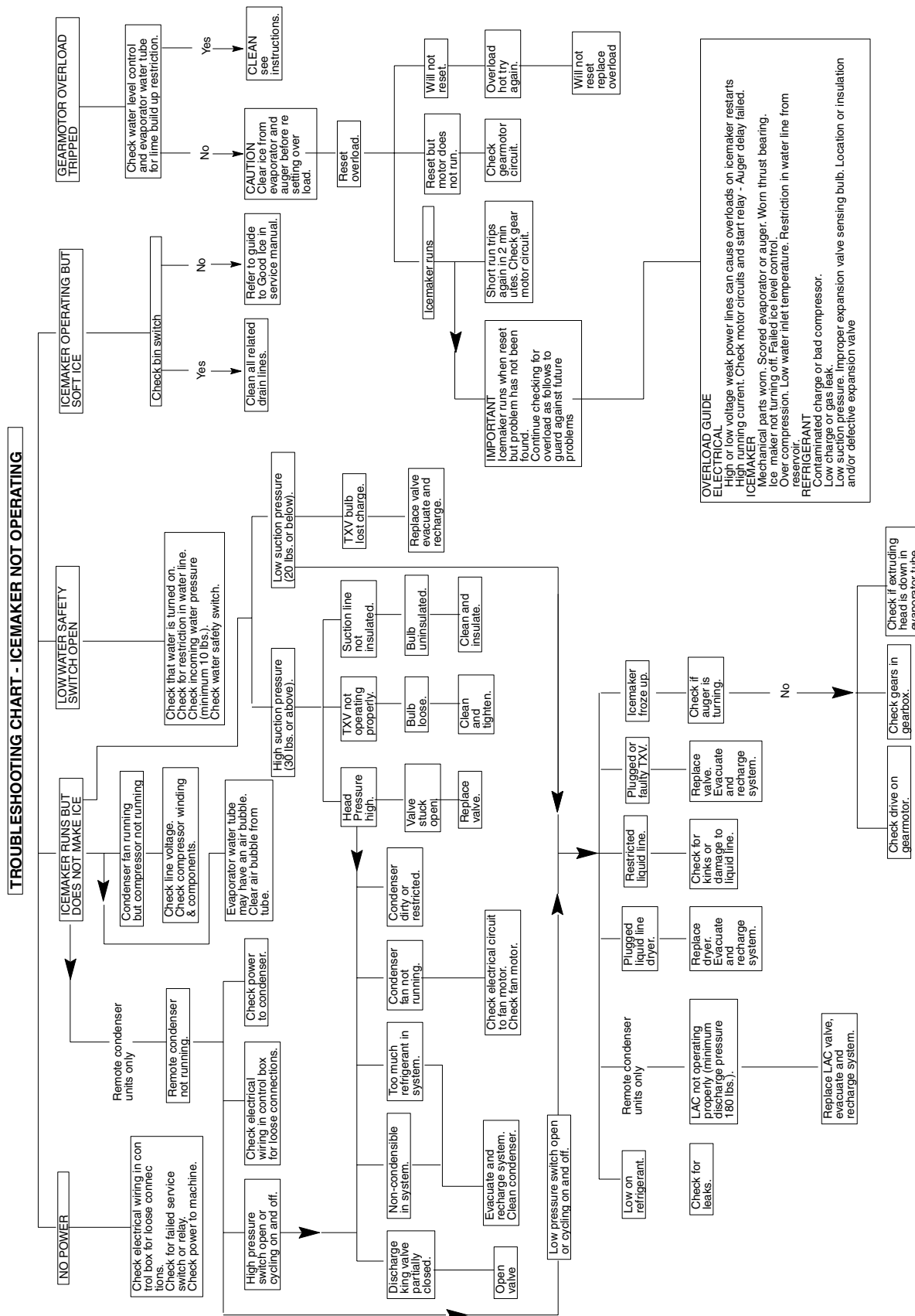



**IMI Cornelius Inc.**  
**[www.cornelius.com](http://www.cornelius.com)**

## Free Manuals Download Website

<http://myh66.com>

<http://usermanuals.us>

<http://www.somanuals.com>

<http://www.4manuals.cc>

<http://www.manual-lib.com>

<http://www.404manual.com>

<http://www.luxmanual.com>

<http://aubethermostatmanual.com>

Golf course search by state

<http://golfingnear.com>

Email search by domain

<http://emailbydomain.com>

Auto manuals search

<http://auto.somanuals.com>

TV manuals search

<http://tv.somanuals.com>