

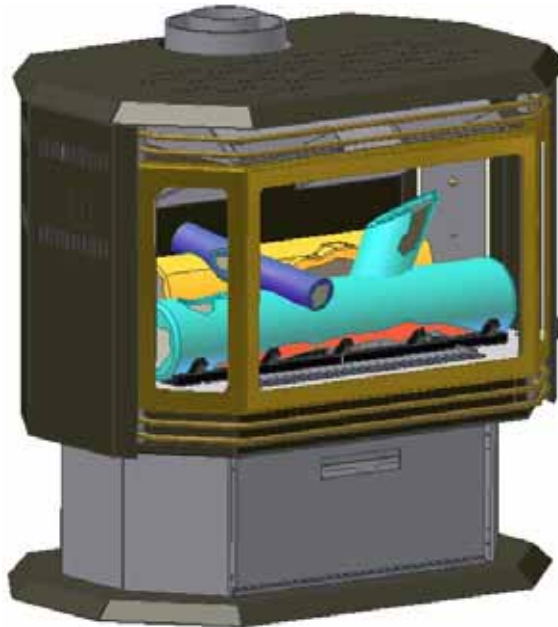

COUNTRY FLAME TECHNOLOGIES

BAYVUE DIRECT VENT GAS STOVE MODEL DV 30 & DV 46 NATURAL GAS OR PROPANE CAPABLE



USA & CANADA TEST STANDARD:
Harmonized ANSI Z21.50 - 2000
CSA 2.22 - 2000, CAN/CGA 2.17

TESTED BY:
WARNOCK HERSEY

Suitable for Bedroom
Installation



WARNING: If the directions contained in this manual are not followed exactly, a fire or explosion may result causing property damage, personal injury or loss of life.

IF YOU SMELL GAS FOR YOUR SAFETY

- Do not light any appliance.
- Do not touch electrical switches; do not use the phone in your building.
- Immediately call the gas company from a neighbor's phone.
- Follow gas company instructions.
- Call the Fire Department if Gas Company doesn't answer.

FOR YOUR SAFETY

Do not store or use gasoline or any flammables (vapors or liquids) in the vicinity of this or any other appliance.
Installation and repair must be performed by a qualified service person or gas supplier.

Country Flame Technologies
A Division of American Products, LLC

900 George Street
Marshfield, MO 65706
417-859-0990
417-859-0192

www.countryflame.com

© 2004

COUNTRY FLAME 

TABLE OF CONTENTS

INTRODUCTION	3
SAFETY INFORMATION	4
INSTALLATION, GENERAL.....	5
PRESSURE TESTING.....	5
ALTITUDE LIMITATIONS.....	6
GAS SUPPLY CONNECTION	6
MINIMUM/MAXIMUM Btu RATES	7
CLEARANCES.....	7
MINIMUM CLEARANCES.....	9
CEILING CLEARANCES	9
TOOL LIST	9
UNPACKING.....	9
LOG PLACEMENT	10
CONTROL PANEL ACCESS	12
HEARTH REQUIREMENTS	12
VALVE ASSEMBLY REMOVAL.....	12
FUEL CONVERSION KITS.....	13
PR CONVERSION KIT BV-4604 CONTENTS	14
PR CONVERSION KIT BV-3004 CONTENTS	14
NG CONVERSION KIT BV-4603 CONTENTS:	14
NG CONVERSION KIT BV-3003 CONTENTS	14
PROPANE CONVERSION KIT	15
NATURAL GAS CONVERSION KIT	15
PROPANE CONVERSION	15
INTAKE AND EXHAUST CONDITIONS.....	18
SEALED VENTING SYSTEM	18
THERMOSTAT/FAN CIRCUIT	18
FAN INSTALLATION	19
DIRECT VENT INSTALLATION	19
GENERAL.....	19
INSTALLATION PRECAUTIONS.....	20
INSTALLER SAFETY PRECAUTIONS	20
VENTING PARTS LIST.....	20
BASIC VENT KITS	21
INSTALLATION PLAN.....	22
VENT (FRESH AIR) REQUIREMENTS.....	22
DIRECT VENT TERMINATION	24
VENT TERMINALS.....	24
STANDARD HORIZONTAL TERMINAL	24
SNORKEL TERMINAL (14" OR 36").....	24
VERTICAL TERMINAL.....	24
CHIMNEY PIPE	24
STANDARD HORIZONTAL VENT	24
VERTICAL AND HORIZONTAL VENT.....	27
VENT GRAPHS.....	28
VENT GRAPH (cont'd).....	29

TABLE OF CONTENTS

SNORKEL VENT	30
VERTICAL VENT.....	30
CATHEDRAL CEILINGS.....	31
MAINTENANCE.....	32
CLEANING BURNERS AND CONTROLS.....	32
REPLACE OLD EMBERS	32
CHECK FLAME AND PILOT	33
GLASS CLEANING	33
CHECK VENT SYSTEM	33
GLASS-CERAMIC SPECIFICATIONS	34
GLASS REPLACEMENT	34
GASKET SPECIFICATIONS.....	34
GENERAL VENT INSPECTION.....	36
GENERAL CLEANING	36
GENERAL SAFETY	36
GENERAL PERIODIC INSPECTIONS.....	36
CLEANING A PAINTED SURFACE.....	36
CLEANING PLATED SURFACES	37
DOOR INSTALLATION.....	37
DOOR SEAL.....	37
MAIN ORIFICES.....	38
GAS FLAME INSPECTION	38
RELIEF VALVE INSPECTON	39
SIT 820 NOVA mV GAS CONTROL VALVE.....	40
WARRANTY	41
TROUBLE SHOOTING GUIDE	42
TROUBLE SHOOTING GUIDE (cont'd)	43
PARTS LIST	44
PARTS LIST (cont'd).....	45
OPERATING INSTRUCTIONS.....	46
LIGHTING INSTRUCTIONS	46
TO TURN OFF GAS TO BAYVUE DV	46
FIRST FIRE.....	46
SAFETY LABEL	47

INTRODUCTION

THANK YOU and CONGRATULATIONS on the purchase of a new gas appliance manufactured by Country Flame Technologies. This purchase makes you part of our family of literally tens of thousands of previous customers who have bought Country Flame's gas and wood products over the past several decades. Country Flame shares our customer's concerns to protect the environment, obtain value for their purchase, and know that they have purchased one of the most reliable gas products the market has to offer.

Each and every employee at Country Flame pledges to ensure each and every one of our customers has our commitment to product support. Product support is dedicated to ensuring our customers achieve the greatest level of satisfaction from the proper use of our products. Thank you for selecting Country Flame. We look forward to hearing from you as this product becomes part of your home heating solution.

This manual is written to provide information that will assure proper installation, proper maintenance, and correct operation of an American made gas fireplace called the Bayvue DV (Direct Vent). It is imperative that the certified professional installer and homeowner read, understand, and follow all information included in this manual to ensure safety and correct operation. If there are questions on installation, operation, or maintenance issues, please re-read and understand all directions and instructions contained in this manual. In the event of any issues or confusion, contact Country Flame or a certified professional before undertaking the installation or operation of this appliance. Installation must be in accordance with local codes, gas supplier restrictions, and conform to current National Fuel Gas Code ANSI Z223.1 (USA) or current CAN/CGA B149 Installation Codes (Canada).

Country Flame wishes you a lifetime of warmth and happiness.

SAFETY INFORMATION

- ⚠ Do not store or use gasoline or other flammables in the vicinity of this appliance.
- ⚠ Do not place clothing or flammable material on or near this appliance.
- ⚠ Due to high operating temperatures, this appliance should be located out of high traffic areas and away from furniture and draperies.
- ⚠ Children and adults should be alerted to the hazards of high surface temperatures and should maintain safe clearances (stay away) to avoid burns or clothing ignition.
- ⚠ Always supervise young children playing in the same room as this operating appliance.
- ⚠ Any safety screen, guard or other parts removed for servicing this appliance must be replaced prior to operation.
- ⚠ **ALL INSTALLATION AND REPAIR SHOULD BE COMPLETED BY A CERTIFIED GAS TECHNICIAN. THIS APPLIANCE SHOULD BE INSPECTED BEFORE USE AND AT LEAST ANNUALLY, BY A CERTIFIED GAS PROFESSIONAL.**
- ⚠ The interior of a gas stove is subject to surface rust due to moisture in the combustion air as well as condensation created during the initial warm up and firing of the gas appliance. At a minimum, annually clean and repaint the interior surfaces to prevent deterioration. More frequent cleaning may be required due to carpet lint, bedding material, dust, etc. being drawn into the appliance. It is imperative that this appliance's control compartment, burners, circulating air system is kept clean.
- ⚠ **WARNING:** IMPROPER INSTALLATION, ADJUSTMENT, ALTERATION, SERVICE OR MAINTENANCE CAN CAUSE INJURY OR PROPERTY DAMAGE. REFER TO THIS MANUAL FOR ASSISTANCE OR FOR ADDITIONAL INFORMATION CONSULT A QUALIFIED INSTALLER, SERVICE AGENCY, OR GAS SUPPLIER.
- ⚠ ALWAYS use high temperature rated silicone or sealing compound at 600°F (316°C) or higher.
- ⚠ This appliance was designed as a sealed unit and as such, the glass doors must be fully intact and closed when operating this gas product.
- ⚠ This appliance was NOT designed, tested, or approved for installation in OEM mobile homes, permanently installed mobile homes, or recreational vehicles and should not be used in such applications.
- ⚠ This appliance was NOT designed, tested, or approved for installation as a fireplace insert. Do not use this appliance in such applications.



PLEASE KEEP THESE INSTRUCTIONS FOR FUTURE REFERENCE

INSTALLATION, GENERAL

The Bayvue DV installation must ensure adequate combustion air and ventilation air is available for proper stove operation. Refer to the venting section for further combustion air requirements. Installation must conform to local codes and gas supplier restrictions. In the absence of local codes, an installation must conform to the current National Fuel Gas Code which at the writing of this manual is ANSI Z223.1 (reference NFPA-54 for natural gas or reference NFPA-58 for propane products). In Canada, an installation must conform to CAN/CGA-B149 code.

This appliance must be electrically connected and grounded in accordance with local codes, or in the absence of local codes, with the current NFPA 70 National Electric Code or in Canada, with CSA C22.1 Canadian Electrical Code.

IT IS IMPERATIVE THAT THIS APPLIANCE'S CONTROL COMPARTMENT, BURNER, AND CIRCULATING AIR PASSAGE WAYS ARE KEPT CLEAN AND CLEAR OF OBSTRUCTIONS. ALWAYS PROVIDE FOR ADEQUATE COMBUSTION AIR AND ENSURE PROPER OPERATION AT ALL TIMES. PROVIDE ADEQUATE CLEARANCES AROUND AIR OPENINGS AND NECESSARY ACCESSIBILITY FOR ROUTINE OPERATION AND SERVICE. NEVER OBSTRUCT ANY OPENINGS ON THIS APPLIANCE OR NEVER OBSTRUCT THE DIRECT VENT TERMINATION ON THE EXTERIOR OF THE BUILDING.

MINIMUM CLEARANCES TO COMBUSTIBLES MUST BE MAINTAINED DURING INSTALLATION. THE HEATER MUST HAVE ADEQUATE SPACE FOR PROPER OPERATION AND SERVICING. MAINTAIN MINIMUM CLEARANCES AND VENT/AIR INTAKE PIPE CLEARANCES.

TABLE 1: BAYVUE DV SPECIFICATIONS

	BAYVUE DV-46		BAYVUE DV-30	
	NATURAL GAS	PROPANE	NATURAL GAS	PROPANE
Altitude	0 - 4500'	0 - 4500'	0 - 4500'	0 - 4500'
Manifold pressure	3.5" W.C.	10" W.C.	3.5" W.C.	10" W.C.
Minimum Inlet Gas Pressure	4.5" W.C.	11" W.C.	4.5" W.C.	11" W.C.
Maximum. Inlet Gas Pressure	7.0" W.C.	14.0" W.C.	7.0" W.C.	14.0" W.C.
BTU Input Rating (High)	46,000	46,000 BTUH	32,000	30,000 BTUH
BTU Input Rating (Low)	29,000	34,500 BTUH	21,000	21,500 BTUH
*Efficiency with fan (steady state)	35,700	36,800 BTUH	24,000	23,100 BTUH
*Efficiency no fan (steady state)	37,200	39,100 BTUH	22,800	22,000 BTUH
*A.F.U.E.	68.77%	70.67%	60.19%	62.22%
Front Burner Orifice	55 DMS	69 DMS	57 DMS	70 DMS
Middle Burner Orifice	45 DMS	55 DMS	50 DMS	59 DMS
Rear Burner Orifice	40 DMS	53 DMS	45 DMS	55 DMS

*ANSI standards are SAFETY STANDARDS not PERFORMANCE STANDARDS. A.F.U.E. (efficiency standards) and efficiency test protocol are established by the U. S. Department of Energy.

PRESSURE TESTING

This appliance MUST BE isolated from the gas supply piping system during any pressure testing of the gas supply piping system at test pressures equal to or less than ½ pounds per square inch gauge (psig) (3.5 kPa or 14" W.C.) Isolate the appliance by closing the manual shutoff valve during pressure testing. Failure to isolate the appliance will cause damage and can require replacement of the SIT 820 NOVA mV gas control valve. If test pressures will be in excess of ½ psig, then the SIT 820 NOVA mV gas control valve must be disconnected from the gas supply line. Refer to FIGURE 27 for SIT 820 NOVA mV valve information.

Country Flame's Bayvue DV stove must be vented vertically or horizontally through an outside wall. This appliance and all its components are tested and safe to operate when installed in accordance with the instructions contained in this manual. Read and understand all instructions before beginning installation to ensure maximum efficiency and safety is achieved. Failure to follow the instructions contained in this manual will void the warranty and may present a fire hazard. Immediately, upon unpacking the product, report any glass or parts damaged, to both the shipping company and the local Country Flame Dealer.

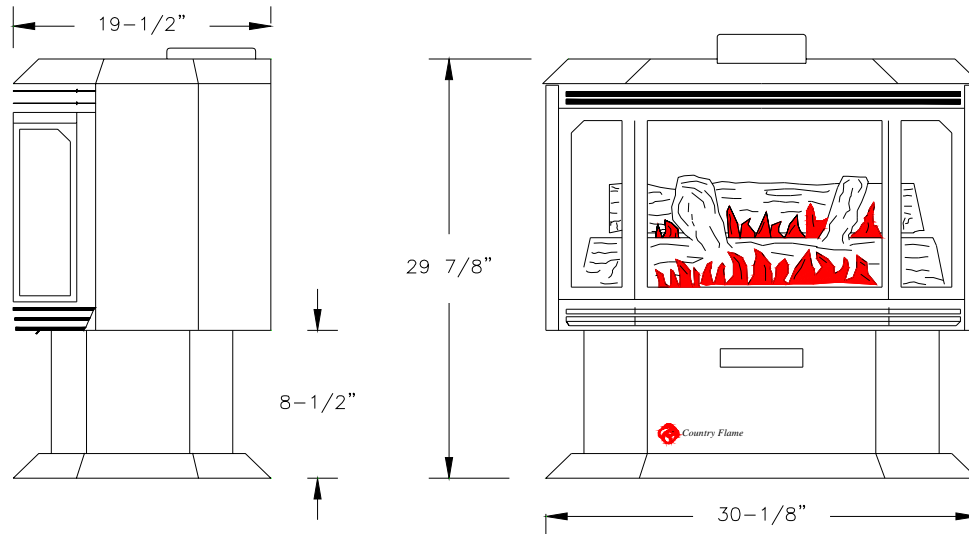

FIGURE 1: BAYVUE DV DIMENSIONS

ALTITUDE LIMITATIONS

United States input ratings of this unit are based on sea level operation. No appliance input rating needs to be changed for any operation at elevations up to 2000 feet (600m). For operation at elevations above 2000 feet, the Bayvue DV's input rating shall be reduced at the rate of 4% for each 1000 feet above sea level. Exception: As permitted by the authority having jurisdiction.

Canadian input ratings of this unit are based on sea level operation. No appliance input rating needs to be changed up to 4500 feet above sea level in Canada. Installation of this appliance at altitudes above 4500 feet is subject to field test of the individual installation and approval by the local authority having jurisdiction.

GAS SUPPLY CONNECTION

A gas supply line must be installed by a qualified professional and must conform to National Standards; NFPA 54 (natural gas) or NFPA 58 (propane) as well as local codes. Connection of the gas supply line shall be made near the lower rear of the appliance. The gas supply line shall be purged of air before connection is made to the appliance. This shut-off valve must be located within 3 feet of the appliance or to the existing local code standard. The Bayvue DV has been tested and approved for installation using a (7/8" O.D. / 1/2" I.D.) Model #1650 N Dormont Flex Connector supplied with the unit. **REMEMBER:** the gas supply line connection must be equipped with an easily visible shut-off valve. Do not run gas supply lines through chimneys, gas vents, dumb waiters, elevator shafts, clothes chutes, or air ducts. Piping should be sloped 1/4" for every 12 feet of horizontal run. The slope will run from the gas meter down to the appliance and the horizontal run shall be supported every 10 feet by suitable gas pipe hangers or straps. Install gas supply line drip leg traps where condensate might accumulate. Sediment traps may be required by code. Traps collect moisture and sediment that might block orifices or valves from operating properly. Depending on the total length of gas supply line being run from the gas company meter to the appliance, different size piping is required. Check with the local gas company for requirements but **NEVER** use plastic or galvanized pipe.

The SIT 820 NOVA mV gas control valve, installed in the Bayvue DV, is supplied with pressure test ports for checking input and output fuel pressures. Refer to FIGURE 27 for valve test port locations. Valve test ports are located below the off/pilot/on control knob. The right port is the OUT (Manifold Pressure) test port and the left port is the IN test port. Pressure is checked by turning the capture screw counterclockwise 2 or 3 turns and then placing tubing from the manometer over the test point. **WARNING:** After taking pressure readings, turn the capture screw clockwise to reseal. Do not over torque. The installer should provide a 1/8" N.P.T. plugged tapped hole** immediately upstream of the gas supply line connection to be used for a test gauge connection. **NOTE: N.P.T. means American Standard Taper Pipe Thread

MINIMUM/MAXIMUM Btu RATES

The Bayvue DV's SIT 820 NOVA mV gas control valve has a HI/LOW knob that is used to regulate the appliance's manifold gas pressure. Refer to FIGURE 27 for location of this manifold control valve. When a pilot flame has been established and the appliance's OFF/PILOT/ON control knob is in the "ON" position, the manifold HI/LOW control knob can be used to adjust the appliances Btu rates. Turning the HI/LOW valve to "HI" allows the appliance to operate at its maximum Btu output rating. Turning the HI/LOW valve to "LOW" allows the appliance to operate at its minimum Btu output rating.

CLEARANCES

The Bayvue DV will heat nearby surfaces when in operation. A safe Bayvue DV installation requires that minimum or greater clearances be maintained between the stove and nearby combustible materials. Failure to maintain proper minimum clearances will cause overheating of combustible materials that can lead to personal property damage or loss of life. Clearances around the appliance must allow for proper servicing of the product. If there is any question about clearances please contact Country Flame or a certified professional. Never reduce clearances below the minimums stated in this manual.

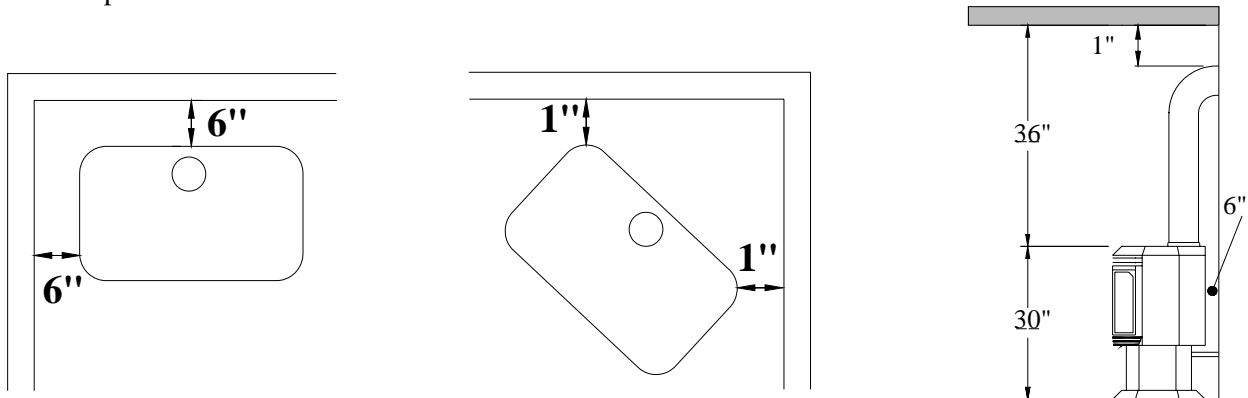

FIGURE 2: BAYVUE DV MINIMUM CLEARANCES

FIGURE 2 shows the minimum clearances required for back wall, side wall, corner, and ceiling installations. These minimum clearances must be maintained in order to ensure proper service can be accomplished and to ensure overheating of combustible materials does not occur. TABLE 2 lists the minimum clearances.

TABLE 2: BAYVUE DV MINIMUM CLEARANCES

CLEARANCE FROM	DISTANCE (INCHES)	DISTANCE (MILIMETERS)
LEFT/RIGHT SIDE WALL	6	152
FLOOR TO CEILING	66	1676
BACK WALL	6	152
UNIT TOP TO CEILING	36	914
HORIZONTAL FLUE	1	25
APPLIANCE CORNER	1	25

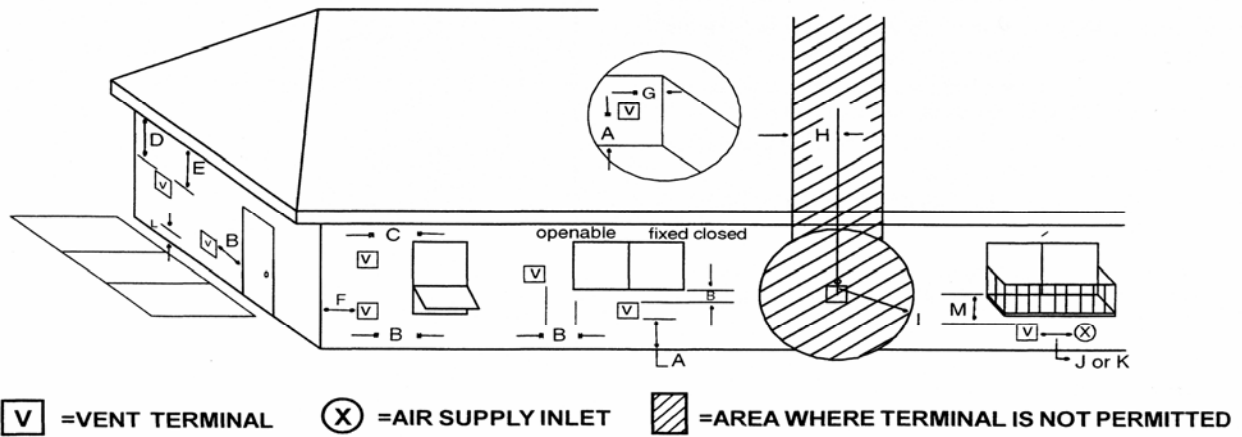

FIGURE 3: CLEARANCE REQUIREMENTS

A	= 12 in.	Clearances above grade, veranda, porch, deck or balcony	I	= 3ft. (U.S.A) = 6ft (Canada)	Clearance to service regulator vent outlet
B	= 12 in.	Clearances to window or door that may be opened	J	= 9 in.(U.S.A) = 12 in. (Canada)	Clearance to non mechanical air supply inlet to building or the combustion air inlet to any other appliance
C	= 9 in. (U.S.A) 12 in(Canada)	Clearance to permanently closed window	K	= 3ft. (U.S.A) = 6ft (Canada)	Clearance to a mechanical air supply inlet
D*	= 18 in.	Vertical clearance to ventilated soffit located above the terminal within a horizontal distance of 2 feet (60 cm) from the center-line of the terminal	**L	= 7 ft.	Clearance above paved sidewalk or a paved driveway located on public property
E*	= 18 in.	Clearance to unventilated soffit	***M	= 18 in.	Clearance under veranda, porch, deck or balcony
F	= 9 in.	Clearance to outside corner			
G	= 6 in.	Clearance to inside corner			
H	= 3 ft. (Canada)	Not to be installed above a gas meter/regulator assembly within 3 feet (90cm) horizontally from the center-line of the regulator			

*	30 in. minimum for vinyl clad soffits	<p>WARNING: In the U.S.A.: Vent system termination is NOT permitted in screened porches. Follow all sidewall, overhang and ground clearances as stated in the instructions.</p> <p>In Canada: Vent system termination is NOT permitted in screened porches. Vent system termination is permitted in a porch area with two or more sides open. Follow all sidewalls, overhang and ground clearances as stated in the instructions.</p> <p>Country Flame Technologies assumes no responsibility for the improper performance of the fireplace when the venting system does not meet requirements.</p>
**	A vent shall not terminate directly above a sidewalk or paved driveway that is located between two single family dwellings and serves both dwellings.	
***	Only permitted if veranda, porch, deck or balcony is fully open on a minimum of 2 sides beneath the floor.	
	NOTE: Local codes or regulations may require different clearances.	

TABLE 3: CLEARANCE DEFINITIONS

MINIMUM CLEARANCES

The Bayvue DV is installed by maintaining minimum clearances to all combustibles including any projections such as shelves, window sills, or fireplace mantles that are located above or around the appliance. Refer to FIGURE 2, FIGURE 3, TABLE 2, and TABLE 3 for clearances.

Sidewalls, both left and right sidewalls where applicable, must maintain minimum clearances to the appliance. Overheating of sidewall material or framing material can occur without proper clearance.

All clearances listed in this manual are considered minimum clearances. All actual installation appliance clearances MUST conform to local installation codes AND MUST conform to any clearance requirements imposed by the local gas supplier.

CEILING CLEARANCES

The minimum ceiling height measured from the top of the appliance to the ceiling is thirty six inches (914 mm). The minimum clearance measured from any part of the horizontal vent pipe to the ceiling is one inch (25 mm).

TOOL LIST

The following tools or equipment are recommended to the certified professional installer to be required during the installation process. Other tools or equipment may be required depending on site specific conditions:

- Various open end wrenches, including 7/16", 1/2", 9/16", and crescent wrenches as needed.
- Various nut drivers' and torx drivers, as required.
- Pipe wrenches.
- Phillips and flat bladed screw drivers.
- Proper gas pipe fitting sealant compound.
- Leak test fluid "U" tube manometer or pressure gauge (0 – 16" WC scale) test equipment.
- Volt/ohm meter.

UNPACKING

STEP 1 Unbolt the stove from the pallet. Discard pallet and packaging material.

STEP 2 Open the stove door on the unit and unpack all components located inside the firebox.

STEP 3 Inspect the interior and exterior of the stove for any shipping damage.

STEP 4 Review the materials list provided with the appliance to ensure all parts needed for installation are present. This should include:

- a) One set of ceramic fiber logs, (total 3 logs). Handle logs with care, extremely fragile.
- b) One bag of ember material.
- c) One installation, operation, and maintenance manual with warranty.

STEP 5 Verify the adjustable air shutter setting is correct per TABLE 4. FIGURE 4 shows the air shutter welded into the end of each burner. There are three air shutters to be checked. FIGURE 4, item A shows the location of the air shutter locking screw, if adjustment is required.



FIGURE 4: ADJUSTABLE BURNER AIR SHUTTER

	Bayvue DV-46		Bayvue DV-30	
NATURAL GAS				
	0 – 2000 FEET	> 2000 FEET	0 – 2000 FEET	> 2000 FEET
FRONT BURNER	1/8 INCH	SAME	1/8 INCH	SAME
MIDDLE BURNER	3/16 INCH	SAME	1/4 INCH	SAME
REAR BURNER	3/8 INCH	SAME	3/8 INCH	SAME
PROPANE				
	0 – 2000 FEET	> 2000 FEET	0 – 2000 FEET	> 2000 FEET
FRONT BURNER	1/8 INCH	SAME	1/8 INCH	SAME
MIDDLE BURNER	FULL OPEN	SAME	5/32 INCH	SAME
REAR BURNER	FULL OPEN	SAME	3/8 INCH	SAME

TABLE 4: AIR SHUTTER ADJUSTMENT

LOG PLACEMENT

The ceramic logs provided with this appliance are extremely fragile. Please handle these three logs with the utmost care. Small chips off of the logs can be covered up using high temp paint. FIGURE 5 and the following steps present log installation instructions. **WARNING: IMPROPER LOG PLACEMENT INSIDE THE FIREBOX CAN CAUSE IMPROPER FUEL BURN, EXCESSIVE CARBON MONOXIDE (a colorless, odorless, toxic gas) PRODUCTION AND RESULT IN SOOTING AN ENTIRE HOUSE. MONITOR THE FIRST FEW FIRES TO ENSURE NO SOOTING.**

- STEP 1** Center the rear log down onto the log retainer's two keys into the log notches. See FIGURE 5a.
- STEP 2** Set the front log into the log retainer using the two outside log grate arms as guides. See FIGURE 5b. Rest front log arm against the back log. Note grooves for top log positioning.
- STEP 3** The top log lays on the left grooves nested on the back and front logs. See FIGURE 5c.
- STEP 4** Embers are placed into and over the front of the "V" shaped front burner. See FIGURE 5d.

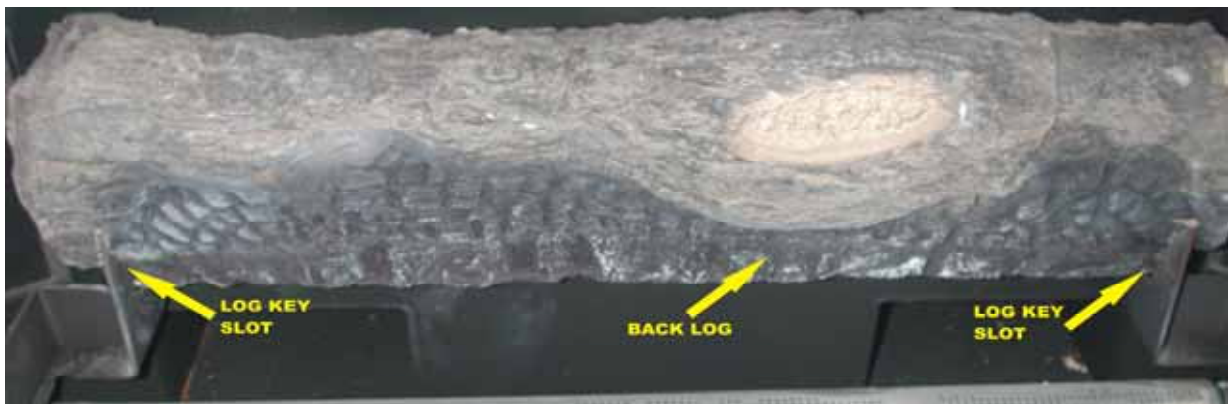

FIGURE 5a: REAR LOG PLACEMENT



FIGURE 5b: FRONT LOG PLACEMENT



FIGURE 5c: LOG SET (3 PIECES EACH)



FIGURE 5d: LOG SET WITH EMBERS

FIGURE 5d also provides a view of a proper flame pattern for the Bayvue DV when the manifold pressure is turned to high or its maximum Btu setting. Note that the embers that are close to the log grate are glowing red. Further, these same embers have a blue flame being emitted from them. This “effect” is because the front burner is designed not only to hold the embers but also to produce a small flame that creates the burning ember effect. The middle and rear burner are designed to produce the “fire” and turn the larger logs red. Note that a blue gas flame can be observed by looking down the front edge of the front log. This flame should be touching “not floating above” the burner. The flame tips will be yellow but no soot should be seen rising from the logs. It should be a very clean burn as shown in FIGURE 5d. Contact a local Country Flame Dealer or certified professional if there is any issue with the flame appearance.

CONTROL PANEL ACCESS

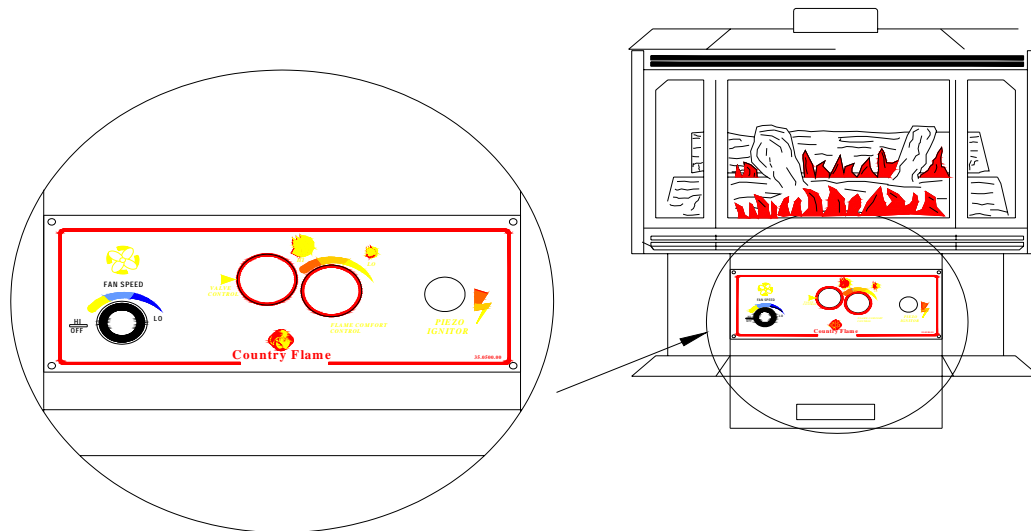

FIGURE 6: CONTROL PANEL

The control panel is accessed through the front door of the Bayvue DV as shown in FIGURE 6. The control panel has controls that adjust the blower fan speed, adjusts the burning setting, includes the burning control, and the piezoelectric igniter control.

HEARTH REQUIREMENTS

When the Bayvue DV is to be installed directly on carpeting, combustible tile or other combustible material other than wood flooring, the carpet or combustible material must be covered first. Other than wood flooring, the floor must be covered with metal, non-combustible tile or wood paneling extending the full width and depth of the appliance. The Bayvue DV can sit on a raised hearth as long as all chimney pipe and all stove minimum clearances are maintained.

VALVE ASSEMBLY REMOVAL

From time to time, it may be necessary to remove the valve assembly. This assembly includes the SIT 820 control valve, the base mounting plate for the burner assembly, the pilot system, the three burner spud (a spud is a removable cap or plug) orifice assemblies, and miscellaneous tubing. If it is ever necessary to remove the valve assembly, take care not to damage any parts. Further, this system, once removed, should be inspected by a certified professional before the valve assembly is reinstalled. The following steps should be followed to ensure no damage occurs in removing the valve assembly. To reinstall the valve assembly, reverse the steps as listed during the installation procedure.

- STEP 1** Remove the control panel front access door by removing the screw hinge pins at the bottom of the door.
- STEP 2** Remove by pulling the rheostat knob off. Remove the four screws holding the control panel front bezel in place and remove the bezel plate. Disconnect the piezoelectric igniter's wire from the igniter.
- STEP 3** Remove the four screws holding the control panel support brackets.
- STEP 4** Remove the two screws holding the heat shield that is directly above the valve access door area.

- STEP 5** Remove the glass door, logs, and embers. Refer to the specific section for each of these items for further instructions on removal and installation of the glass door, logs, and embers. Remove the three burner retaining screws and slide the burners off the burner spud orifice holders and remove the front, middle, and rear burners. It is critical to ensure each burner is marked so the correct burner is located in the same position it was removed from.
- STEP 6** Remove the nine screws sealing the complete burner assembly to the bottom of the stove.
- STEP 7** Disconnect the wiring to the terminal block and disconnect the gas.
- STEP 8** Lift the complete gas valve assembly out of the stove. FIGURE 7 shows the assembly.

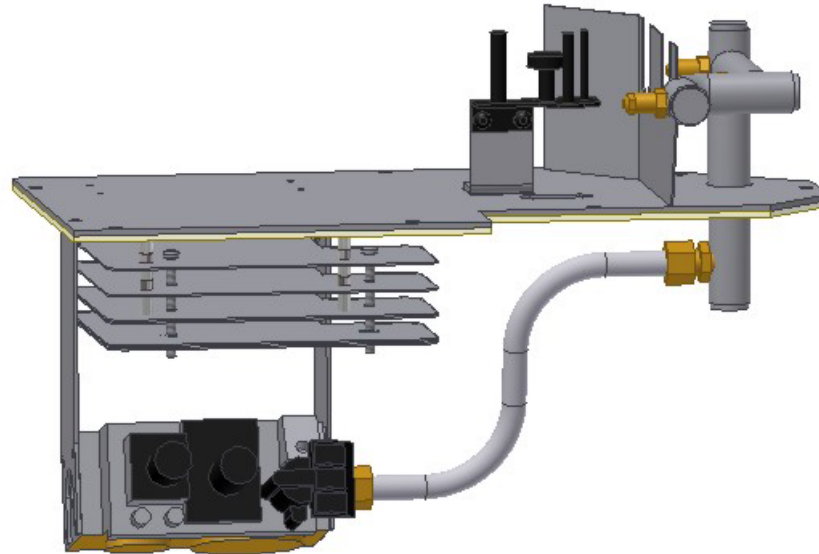

FIGURE 7: GAS VALVE ASSEMBLY

FUEL CONVERSION KITS

WARNING: Conversion kits shall be installed by a qualified service agency in accordance with the manufacturer's instructions and all applicable codes and requirements of the authorized agency having jurisdiction. If the information in these manufacturer's instructions are not followed exactly, a fire, explosion or production of carbon monoxide may result causing property damage, personal injury or loss of life. The qualified service agency is responsible for the proper installation of this kit. The installation is not proper and complete until the operation of the converted appliance is checked as specified in the owner instructions supplied with the conversion kit.

The next several pages explain the conversion kits and step by step procedures to complete conversions. This information is provided for homeowner reference but all conversions are to be completed by a certified professional.

In the event of any problem with a Country Flame conversion kit or the installation of the kit, please contact a local authorized Country Flame Dealer or contact Country Flame directly to obtain additional information and assistance in properly resolving the problem.

PR CONVERSION KIT BV-4604 CONTENTS:

ITEM	QTY	PART NUMBER	ITEM DESCRIPTION
Regulator	1	GC-3906-01	SIT 820 NOVA mV Gas Valve
Pilot Orifice	1	BV-4614	#35 Pilot Injector Orifice
Front Spud Orifice	1	BV-4626	69 DMS LP Front Orifice Spud
Middle Spud Orifice	1	BV-4627	55 DMS LP Middle Orifice Spud
Rear Spud Orifice	1	BV-4628	53 DMS LP Rear Orifice Spud
Conversion Label	1	35-0500-01	Conversion NG to LP
Instructions	1	BV-4650	Conversion Kit Instructions

PR CONVERSION KIT BV-3004 CONTENTS:

ITEM	QTY	PART NUMBER	ITEM DESCRIPTION
Regulator	1	GC-3906-01	SIT 820 NOVA mV Gas Valve
Pilot	1	BV-4614	#35 Pilot Injector Orifice
Front Spud Orifice	1	BV-4632	70 DMS LP Front Orifice Spud
Middle Spud Orifice	1	BV-4633	59 DMS LP Middle Orifice Spud
Rear Spud Orifice	1	BV-4634	55 DMS LP Rear Orifice Spud
Middle Burner	1	BV-4620	Middle Burner for 30,000Btu
Rear Burner	1	BV-4622	Rear Burner for 30,000Btu
Conversion Label	1	35-0500-03	Conversion NG to LP
Instructions	1	BV-4650	Conversion Kit Instructions

NG CONVERSION KIT BV-4603 CONTENTS:

ITEM	QTY	PART NUMBER	ITEM DESCRIPTION
Regulator	1	GC-3905-01	SIT 820 NOVA mV Gas Valve
Pilot	1	BV-4613	#51 Pilot Injector Orifice
Front Spud Orifice	1	BV-4623	55 DMS NG Front Orifice Spud
Middle Spud Orifice	1	BV-4624	45 DMS NG Middle Orifice Spud
Rear Spud Orifice	1	BV-4625	40 DMS NG Rear Orifice Spud
Conversion Label	1	35-0500-02	Conversion LP to NG
Instructions	1	BV-4650	Conversion Kit Instructions

NG CONVERSION KIT BV-3003 CONTENTS:

ITEM	QTY	PART NUMBER	ITEM DESCRIPTION
Regulator	1	GC-3905-01	SIT 820 NOVA mV Gas Valve
Pilot	1	BV-4613	#51 Pilot Injector Orifice
Front Spud Orifice	1	BV-4629	57 DMS NG Front Orifice Spud
Middle Spud Orifice	1	BV-4630	50 DMS NG Middle Orifice Spud
Rear Spud Orifice	1	BV-4631	45 DMS NG Rear Orifice Spud
Middle Burner	1	BV-4620	Middle Burner for 30,000Btu
Rear Burner	1	BV-4622	Rear Burner for 30,000Btu
Conversion Label	1	35-0500-04	Conversion LP to NG
Instructions	1	BV4650	Conversion Kit Instructions

NOTE: Conversion kits are available only for natural gas and propane fuel.

NOTE: A Country Flame conversion kit is to be installed only by certified service technicians.

NOTE: Check kit contents for all parts. Do not attempt conversion with items missing.

NOTE: A Torx T20 Tamper-Proof screwdriver may be separately ordered if needed.

NOTE: **D.M.S.** (DMS is Drill Manufacturer's Standard) Standard twist drill or steel wire gauge number.

△ WARNING: The gas supply **MUST BE SHUT OFF** prior to disconnecting the electrical power and before proceeding with ANY conversion kit installation.

A certified service technician will require one of the following Country Flame certified conversion kits, depending on the type of conversion being planned.

PROPANE CONVERSION KIT

To convert from natural gas to propane fuel follow conversion Steps 1 through 15 starting on this page, using one of the following conversion kits:

Bayvue DV-46N to DV46P Kit BV-4604

Bayvue DV-30N to DV46P Kit BV-3004

NATURAL GAS CONVERSION KIT

To convert from propane to natural gas fuel follow conversion Steps 1 through 15 starting on this page, using one of the following conversion kits:

Bayvue DV46P to DV46N Kit BV-4603

Bayvue DV30P to DV46N Kit BV-3003

PROPANE CONVERSION

Bayvue DV appliances are shipped from the Country Flame factory set for 46,000 Btu Natural Gas fuel usage; however, conversion kits may be purchased from Country Flame to convert the Bayvue DV to different fuels (propane or natural gas) or lower the heat output to 30,000 Btu. Depending on the specific model owned and being converted, conversion kits contain different replacement parts that are kit specific. Conversion requires adjustment to the regulators, the burners, and the pilot system. Refer to TABLE 1 and page 4 and page 5 for the correct gas pressures corresponding to the conversion kit being used.

⚠ WARNING: This conversion kit shall be installed by a qualified service agency in accordance with the manufacturer's instructions and all applicable codes and requirements of the authorized agency having jurisdiction. If the information in these instructions are not followed exactly, a fire, explosion or production of carbon monoxide may result causing property damage, personal injury or loss of life. The qualified service agency is responsible for the proper installation of this kit. The installation is not proper and complete until the operation of the converted appliance is checked as specified in the owner instructions supplied with the kit.

- STEP 1** Turn the control knob to the OFF position and turn off the gas supply to the valve.
- STEP 2** Remove control knob extensions from the valve. Allow system to cool before proceeding.
- STEP 3** Remove the control panel by removing the two screws located at the top of the panel. Disconnect the wire from back of piezoelectric igniter. Disconnect wires from on/off switch and variable speed control if required.
- STEP 4** Refer to FIGURE 8 and using a Torx T20 screwdriver, remove and discard the three pressure regulator mounting screws (Item A), the pressure regulator tower (Item B), and the diaphragm assembly (Item C).

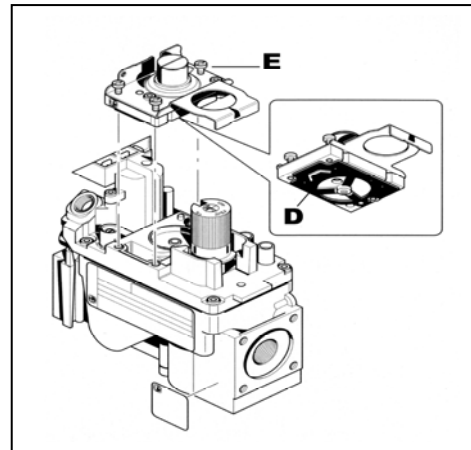
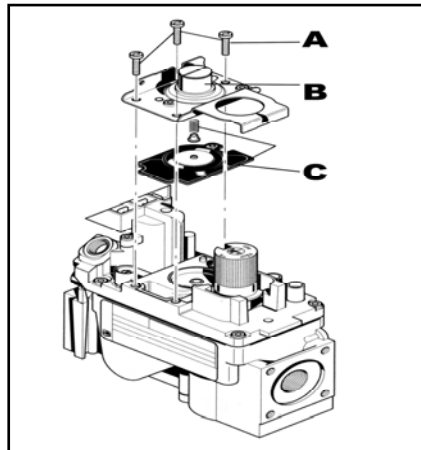

FIGURE 8: SIT 820 NOVA mV GAS CONTROL VALVE

- STEP 5** Refer to FIGURE 8. Ensure that the rubber gasket (Item D) is properly positioned and install the new HI/LO pressure regulator assembly to the valve using the supplied screws (Item E). Tighten screws securely.
- STEP 6** Attach the enclosed "conversion" label near the certification label.
- STEP 7** Re-attach all wiring to the fan control knob and the piezoelectric igniter. Replace the access panel and tighten the two screws. Replace the control knobs.
- STEP 8** Remove the door, the logs, and the embers, noting the position of each log as it is removed.
- STEP 9** Remove the two screws holding the ember tray in place. Lift up the ember tray and remove.
- STEP 10** Remove the three burners. Mark each burner as to their location. Refer to FIGURE 4 and TABLE 4 for proper air shutter adjustment for each burner. Adjust each burner's air shutter to meet fuel conversion requirements. **NOTE:** Use the shank of an appropriately sized drill bit as an air shutter gauge. Pass the gauge through both sides of the air shutter, adjust and lock the shutter removing the gauge when finished making adjustments.
- STEP 11** Use a 3/8-inch (10mm) wrench to remove and discard the burner spud orifices. Place the new burner spud orifices in the appropriate location per the conversion kit instruction or refer to page 12 for the proper location of each labeled burner spud orifice.
- STEP 12** Remove and replace the pilot gas orifice located in the **PILOT FLAME DIFFUSER BODY**.
- Remove the pilot flame diffuser (FIGURE 9, Item B) by pulling up on it. The retainer clip (FIGURE 9, Item A) should release the pilot flame diffuser with a light pulling motion.
 - Remove the pilot gas orifice (FIGURE 10, Item F) by using a 5/32 hex head wrench (Allen wrench) placed in the top of the pilot gas orifice.
 - Verify the correct pilot gas orifice number per page 14 kit definitions. Reinstall and tighten the new pilot gas orifice and replace the pilot flame diffuser by reinserting it into the retainer clip.

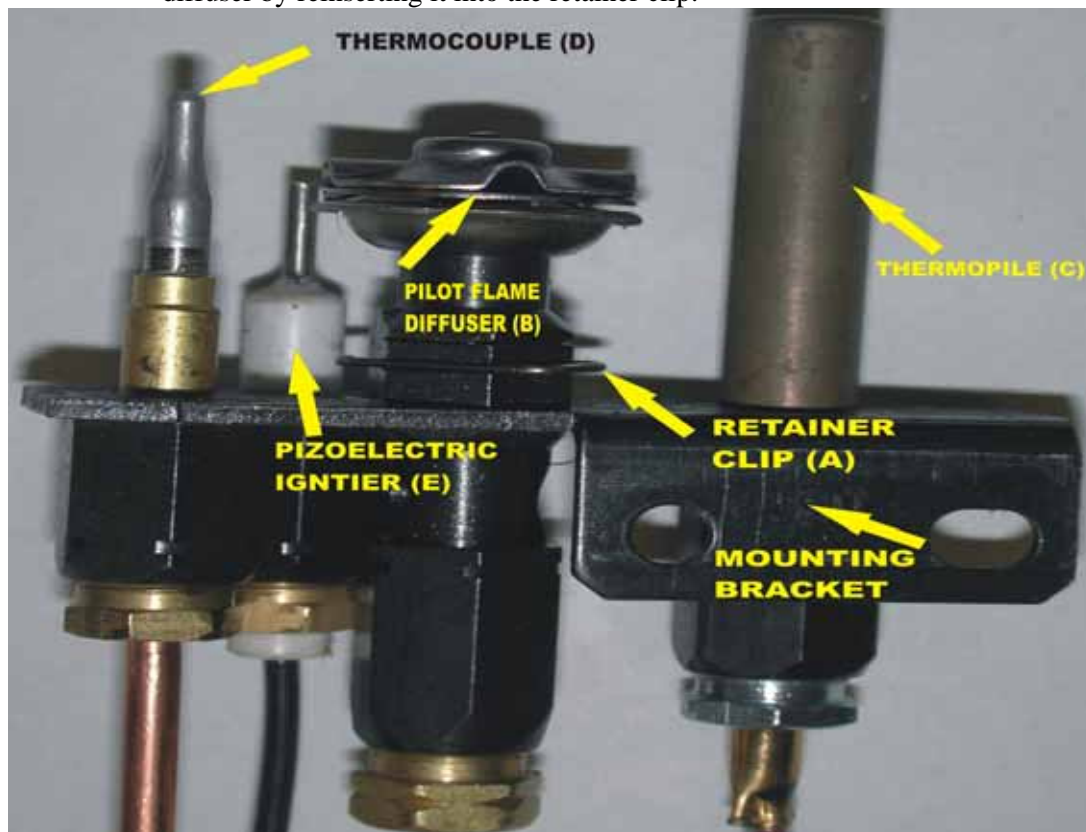

FIGURE 9: PILOT VALVE (back side)

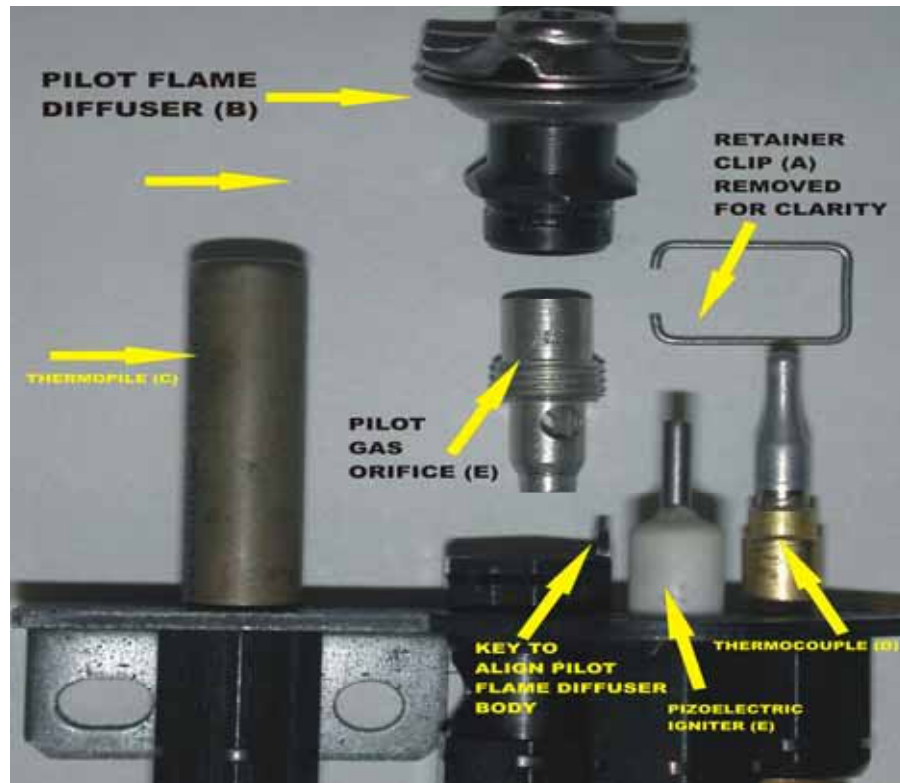

FIGURE 10: PILOT VALVE

STEP 13 Refer to FIGURE 11, Note (X). The piezoelectric igniter cannot be installed incorrectly unless it is damaged. The piezoelectric igniter should be in a parallel plane to the pilot flame diffuser body. Each time the igniter button is pressed, a blue arc should occur from the piezoelectric igniter to the pilot flame diffuser body. Replace the burners, the ember tray, the logs, the embers, and the door, ensuring correct position of all components.

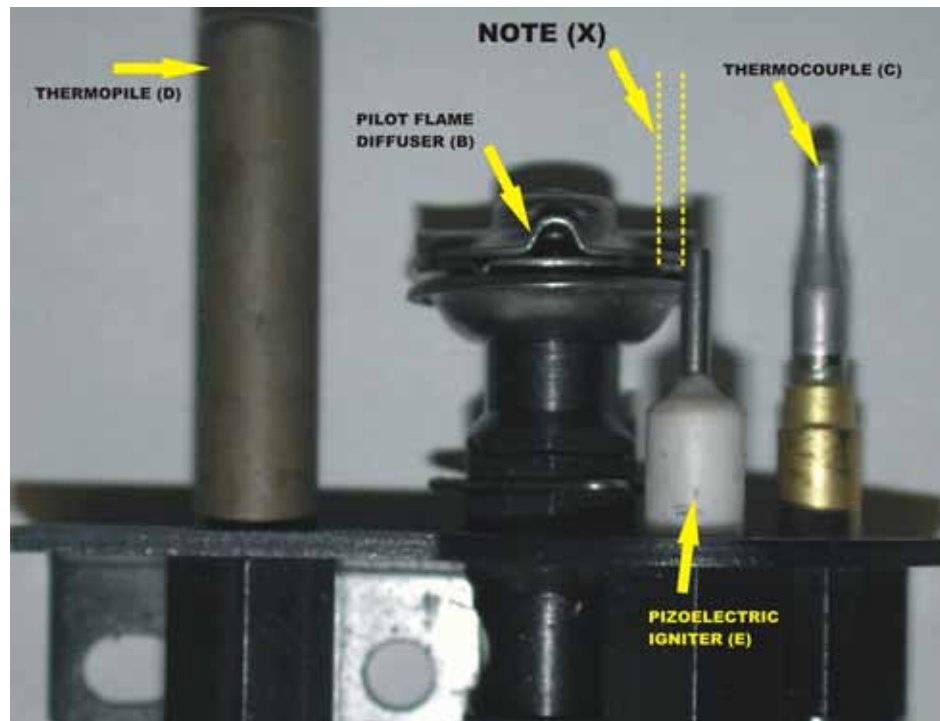

FIGURE 11: PILOT VALVE

STEP 14 Open the gas supply and perform gas leak test. One of the best methods used to check for gas leaks is soap bubbles. Soap bubbles are made by mixing liquid detergent with a little water and shaking vigorously to create soap bubbles. Cover the gas pipe joint or valve component with these soap bubbles. If soap bubbles grow in size or the bubbles are blown off the connection, a gas leak exists. Make necessary repairs and retest until no change in soap bubbles is seen at any joint or valve connection.

⚠ WARNING: DO NOT USE AN OPEN FLAME TO CHECK FOR GAS LEAKS

STEP 15 Re-light the appliance. Check the flame control operation.

NATURAL GAS CONVERSION

Conversion from propane to natural gas follows the same 15 steps listed above using the parts from a natural gas conversion kit. Adhere to the following:

NOTE: Conversion kits are to be installed by qualified service technicians.

NOTE: Do not install a kit IF conversion items are missing; check kit for all parts needed.

NOTE: A Torx T20 Tamper-Proof screwdriver may be ordered separately if needed.

INTAKE AND EXHAUST CONDITIONS

WARNING: (Safety relief valves) Operation of this appliance with an improperly installed or an improperly maintained venting system could result in carbon monoxide poisoning. Make sure that all safety relief valves are closed and free from obstruction at all times. This is crucial in terms of operational safety. **IT IS STRONGLY RECOMMENDED THAT A CARBON MONOXIDE DETECTOR BE PLACED IN THE VICINITY OF THIS PRODUCT TO ENSURE MAXIMUM SAFETY. IF BATTERY OPERATED DETECTORS ARE USED, REPLACE THE BATTERY ANNUALLY.**

SEALED VENTING SYSTEM

The Bayvue DV is designed for a sealed vent system. This means that all flue connections, including all seams and joints, are to be sealed with high temperature silicone rated for a minimum of 600°F (316°C) to ensure that a proper draft occurs during appliance operation. If it becomes necessary to disassemble the venting, proper care must be used to reassemble and reseal the vent air intake assembly.

THERMOSTAT/FAN CIRCUIT

The Bayvue DV is pre-wired to accept a millivolt wall thermostat and includes as standard, a room air blower fan assembly. This blower is equipped with a three-prong 120 VAC grounded power cord that protects against shock hazard. This plug should be connected directly into a properly grounded three-prong receptacle. Do not cut or remove the grounding pin from the blower's plug.

The room air blower fan system is activated once the power cord explained in the preceding paragraph has been plugged in. The fan circuit is activated along with the heat sensing thermo-disc and the fan speed control rheostat. A wall thermostat can be connected to the terminal block on the back of the pedestal. Simply remove the factory installed jumper and wire in the thermostat. Refer to FIGURE 12. **CAUTION:** Label all wires prior to disconnection when servicing the controls or the blower system. Wiring errors can cause improper and dangerous operational conditions. **ALWAYS** verify proper operation of the Bayvue DV product after any servicing. Should any problems or operational issues be noted after servicing has been completed, **DO NOT USE THE SYSTEM** until corrections have been made.

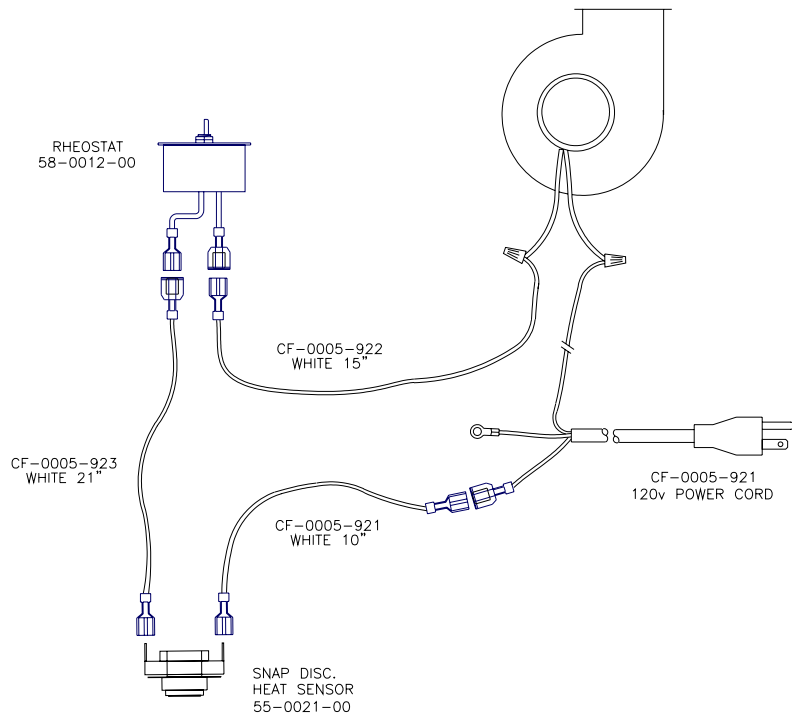
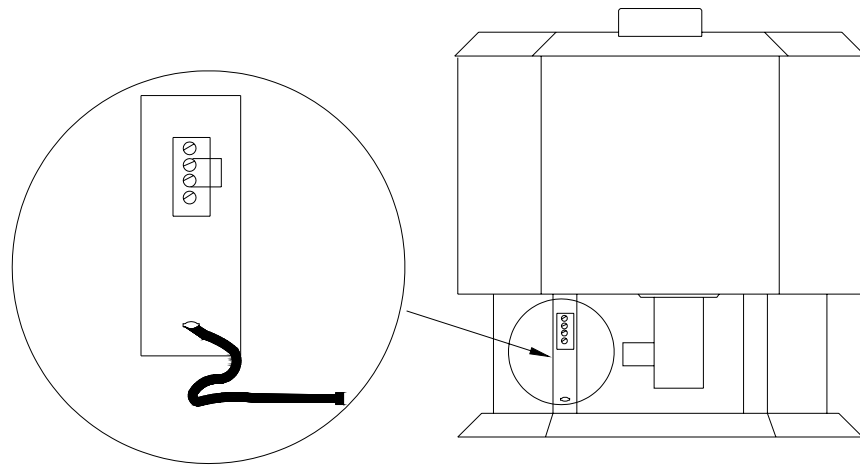

FIGURE 12: BLOWER FAN

FAN INSTALLATION

The Bayvue DV comes standard with the fan kit installed. The Fan Kit consists of a blower system. The fan is connected to the Bayvue DV's wiring harness. The Bayvue DV is pre-wired for and includes a rheostat (speed control), a heat activated thermo-disc and a 120 volt receptacle. The fan slips inside the back of the pedestal into two slides mounted to the bottom of the firebox.

DIRECT VENT INSTALLATION

GENERAL

Country Flame Bayvue DV product is approved for side wall vent or vertical vent through a roof. Only Simpson Dura Vent chimney components or Selkirk Model Direct-Temp chimney components may be used with this product. Simpson Dura Vent chimney vent products are listed in this manual to assist with vent installation selection. Read all these instructions carefully before starting the installation. Failure to follow instructions may create a fire or other safety hazard, and will void the product warranty. Be sure to follow installation instructions and maintain proper venting and maintain clearances to combustibles that will vary from one installation to another.

INSTALLATION PRECAUTIONS

The Simpson Dura Vent Direct Vent System and the Selkirk Model Direct-Temp System are engineered products that have been designed and tested for use with the Country Flame Bayvue DV product. The chimney pipe product warranty will be voided and serious fire, health, or other safety hazards may result from any of the following actions:

- Installation of any damaged venting component.
- Unauthorized modification of the venting system.
- Installation of any component part not approved by Country Flame.
- Installation other than as instructed by these instructions.
- Conform to all local building codes during product installation.

WARNING

Always maintain required clearances (air space) to nearby combustibles to prevent a fire hazard. Do not fill air space with insulation. Minimum clearance between vent pipes and combustible surfaces is 1 inch (25mm) except where stated otherwise. Be sure to check the vent termination clearance requirements from decks, window soffits, gas regulators, air supply inlets, and public walkways, as specified in these installation instructions and local building codes. (Refer to the drawing for horizontal termination locations).

The gas appliances and vent system must be vented directly to the outside of the building, and never be attached to a chimney serving a separate solid fuel or gas-burning appliance. This direct vent gas appliance must use its own separate vent system. Common vent systems are prohibited and void the warranty.

INSTALLER SAFETY PRECAUTIONS

- Wear gloves and safety glasses for protection.
- Take note of all power lines when using ladders or working on roof tops.
- Be aware of electrical wiring locations in walls and ceilings.
- Properly use ladders and ensure safe angles for use.

VENTING PARTS LIST

The Simpson Dura Vent Direct Vent System offers a complete line of component parts for installation of both horizontal and vertical installations. Many items are offered in decorative black, as well as galvanized finish. The galvanized pipe and fittings are used for concealed locations such as attics, or spaces where corrosion is a factor, such as above the roof line. Decorative plated trim kits are available for both wall thimbles and ceiling support boxes. Snorkel terminations are available for applications which may require vertical rise on the building exterior. The components listed in TABLE 5 have been approved for use with the Country Flame Bayvue DV Stoves.

Country Flame Part #	Dura-Vent Part #	Description
CF-11010	908B	6" Pipe Length, Black
CF-11011	907B	9" Pipe Length, Black
CF-11012	906	12" Pipe Length
CF-11013	906B	12" Pipe Length, Black
CF-11014	904	24" Pipe Length
CF-11015	904B	24" Pipe Length, Black
CF-11016	903	36" Pipe Length
CF-11017	903B	36" Pipe Length, Black
CF-11018	902	48" Pipe Length
CF-11019	902B	48" Pipe Length, Black
CF-11020	911B	11" to 14-5/8" Pipe, Adjustable, Black
CF-11030	945	45 Degree Elbow
CF-11031	945B	45 Degree Elbow, Black
CF-11032	990	90 Degree Elbow
CF-11033	990B	90 Degree Elbow, Black
CF-11051	940	Round Support Box/ Wall Thimble cover
CF-11058	942	Wall Thimble
CF-11052	941	Cathedral Ceiling Support Box
CF-11055	943	Flashing, 0/12 to 6/12 Roof Pitch
CF-11056	953	Storm Collar
CF-11054	963	Ceiling Fire stop
CF-11057	988	Wall Strap
CF-11043	981	Snorkel Termination (36")
CF-11044	982	Snorkel Termination (14")
CF-11040	984	Horizontal Square Termination
CF-11041	983	Vertical Termination
CF-11050	950	Vinyl Siding Standoff

TABLE 5: DURA-VENT PARTS LIST

BASIC VENT KITS

CF-11000 This standard termination kit includes the following:

- CF-11033 1 each - 90 Degree Black Elbow
- CF-11051 1 each - Round Ceiling Support/ Wall Thimble Cover
- CF-11040 1 each - Horizontal Square Cap

Note: The above kit is not a complete termination system. Order straight pipe lengths, as needed.
In Canada, a wall thimble is required to complete an installation.

CF-11001 This standard termination kit includes the following:

- CF-11033 1 each - 90 Degree Black Elbow
- CF-11051 1 each - Round Ceiling Support/ Wall Thimble Cover
- CF-11040 1 each - Horizontal Square Cap
- CF-11015 1 each - 24" Black Pipe
- CF-11020 1 each - 11" - 14 5/8" Black Adjustable Pipe

Note: In Canada, a wall thimble is required to complete an installation.

CF-11002 This vertical termination kit includes the following:

- CF-11055 1 each - Flashing 0/12 - 6/12
- CF-11056 1 each - Storm Collar
- CF-11041 1 each - Vertical Termination Cap

Note: The support box is not included in the kit.

INSTALLATION PLAN

VENT (FRESH AIR) REQUIREMENTS

The Bayvue DV burns fuel by combining the proper amount of natural gas or propane with fresh air to obtain complete combustion. During heavy natural gas demand periods (extremely cold consecutive days) the local gas supplier may provide “filler gasses” with the natural gas fuel supply. This mixed gas may cause a change in burner flame appearance. This may cause soot to form on the logs and viewing windows. In the event any change in the burn pattern is noticed, contact the local gas supplier to obtain additional information and contact a certified professional to clean and adjust the appliance, if necessary.

It is imperative to ensure delivery of the proper amount of fresh combustion air to gas appliances. The Bayvue DV (direct vent) chimney system brings all combustion fresh air requirements through a dual chimney pipe and exhausts the spent combustion gasses back through the chimney pipe system. Failure to properly seal the direct vent chimney system will allow leaks that will prevent the proper amount of fresh air from being available for combustion or can potentially leak harmful combustion gasses back into the home. Failure to provide adequate combustion air will cause operational problems, increased maintenance issues, and potential failure of the gas stove to perform to its designed standard. For specific details on combustion air requirements, refer to the current NFPA-54 (natural gas) or NFPA-58 (propane) and the current ANSI Z223.1 standards. Although direct vent gas appliances are designed to minimize fresh air issues, the homeowner should understand fresh air requirements for all fuel burning appliances in a home and also understand the interaction these appliances can have on each other and the availability of fresh air in the home. The next several paragraphs explain and provide examples of fresh air issues.

Modern construction techniques are making new homes tighter and tighter to air infiltration. This is good in one sense as it reduces the amount of energy required to maintain a home at a comfortable temperature; however, this is bad in another sense because without an adequate fresh air supply, these new air tight homes become “stale or depleted of fresh air.” Most new airtight homes come with air exchange systems that replace inside home air with fresh outside air so many times an hour. This air exchange system is balanced to the number of occupants and the fuel burning appliances located in the home. If additional combustion devices are added to a home, a certified professional should rebalance the air exchanger. Rebalancing the system adjusts for the fresh air usage of any new combustion appliance. Rebalancing the air exchanger ensures proper amounts of fresh air for the home occupants and other appliances. If your home contains an air exchange system, contact a local certified professional to have a fresh air analysis done while the Country Flame appliance is being installed.

A homeowner needs to understand the terms “restricted” and “unrestricted” air space. Even though properly installed direct vent chimney systems eliminate combustion air requirements there is still the requirement for ventilation air. If a home is not air tight, depending on room configuration and other fresh air barriers, a gas appliance can still be installed in too small a room and “starved or restricted” from receiving the proper amount of necessary air. Again, this is not true of Direct Vent appliances whose chimneys provide for combustion air; however, direct vent appliance chimney systems do not provide for ventilation air requirements. Determining the amount of fresh air available to a gas appliance is a relatively easy mathematical exercise. Get out the old calculator and follow the examples provided. First, here are the “official” definition of terms:

a) **Space:** a room where a gas appliance is to be placed. The total space required to ensure proper fresh air to a gas appliance can include additional space or room(s) if there is no restriction to airflow between the space(s) or room(s). “Unrestricted” space means (i) no closable doors can exist between rooms or (ii) there must be proper sized grills (non-closing) placed between adjoining spaces or rooms. If closable doors exist or no grills exist between adjoining rooms, then the adjoining space next to where the gas appliance is to be located cannot be included in the calculation to determine if adequate fresh air exists for proper operation of the gas appliance.

b) **Unrestricted space:** is defined as an area that provides at least 50 cubic feet of air volume for each 1,000 Btu per hour of input heat rating of a gas appliance. The 50 cubic feet of fresh air volume is made up of primary (combustion) and secondary (heated) air requirements. Vented gas appliances use 10

cubic feet of the available volume of air for primary (combustion) air. Again, Direct Vent gas appliances fulfill combustion air requirements by providing this air through the chimney system. The additional 40 cubic feet of fresh air is heated and moved throughout the home as secondary (ventilation) air. Thus, for the Bayvue DV to operate properly the appliance requires 1,840 cubic feet of unrestricted air space. This requirement was determined by taking the 46,000 Btu/H and dividing it by 1,000 Btu/H which equals 46. Now multiply 46 times the 40 cubic feet (ventilation air only) requirement which equals 1,840 cubic feet of room space. If a Country Flame vented appliance was being installed, the minimum room size would increase to 2,300 square feet as combustion air would have to be supplied by the room. Always use the highest Btu/H rating of an appliance to determine the maximum fresh air requirement before an appliance is placed in a room. NOTE: Cubic feet equals the length times width times height of the room where the gas appliance is to be installed. Adjoining spaces air volume can be included only if the spaces are connected by doorless passageways or non closing grills that connects to the room where the gas appliance is installed.

c) **Restricted space:** is defined as an area that has less than 50 cubic feet of air volume for each 1,000 Btu per hour of input heat rating of the gas appliances installed in that area. **WARNING: NEVER install a gas appliance in a restricted space unless adequate airflow is provided for proper combustion and ventilation (primary and secondary air) to that restricted space.**

EXAMPLE 1: A basement room is going to have a gas heater installed. The room is 8'4" by 18'7" by 23'0" for a total air volume of 3,561.8 cubic feet. Divide the rooms cubic feet of air space by 50 cubic feet (40 cubic feet if a direct vent system was being installed) which gives 71.24. Multiply 71.24 times 1,000 Btu/H. This means that as long as the appliance being installed in this particular room has less than a 71,236 Btu/H input rating, there is enough air volume to support proper combustion and ventilation air. This specific example would be classified as an unrestricted space.

EXAMPLE 2: A room will have a direct vent fireplace installed that has an input rating of 26,200 Btu/H. An adjoining room connected by a doorless passageway contains a 60,000 Btu/H rated furnace. The room where the direct vent appliance will be installed is 10' by 15' by 8' with an air volume of 1,200 cubic feet. The adjoining room is 12' by 16' by 8' for an air volume of 1,536 cubic feet. Total air volume of the two rooms is 2,736 cubic feet. Divide 1,200 cubic feet by 40 cubic feet equals 30. Divide 1,536 cubic feet by 50 cubic feet equals 30.72. Add the two numbers (30 plus 30.72) equals 60.72. Multiply 60.72 times 1,000 Btu/H equals 60,720 Btu/H. This final number (60,720) indicates the maximum input rating any appliance the adjoining room's air volume can properly provide combustion and ventilation air for. At the same time, the total Btu/H input ratings of the appliances that will be installed is 86,200 Btu/H. This means **EXAMPLE 2** rooms are classified as RESTRICTED AIR SPACE because 86,200 Btu/H appliance use is greater 60,720 Btu/H room air. Additional air must be provided to this area to meet air requirements when both appliances are operating at the same time. RESTRICTED AIR SPACE can be ventilated in a number of different ways to meet the combustion and ventilation air requirements of the appliances installed.

METHOD A: Vent the area directly to the outdoors. Use one square inch of opening for each 4,000 Btu/H of additional air required. For **EXAMPLE 2**, there is a requirement for an additional 25,480 Btu/H of air requirement. Divide 25,480 by 4,000 equals 6.37. Thus, an opening would have to be provided to the outdoors that has an open area of 6.37 square inches in order to satisfy the air requirements for the appliances and room sizes given in **EXAMPLE 2**.

METHOD B: Additional air can also be accomplished by creating doorless passages to other rooms or providing venting grills to other rooms. If venting grills are to be used, they would need to provide a minimum of 50 square inches of opening and any one side must be greater than 5 inches. At the same time a minimum of two grills are required. One grill should be located within 12 inches from the floor and one grill should be 12 inches from the ceiling. Again, refer to the National Fuel Codes for information concerning restricted or confined air space.

DIRECT VENT TERMINATION

There are two types of direct vent termination that can be used with the Bayvue DV appliance:

- Horizontal Termination
- Vertical Termination

VENT TERMINALS

There are four types of vent terminals available for the Bayvue DV appliances. Three of these vent terminal types apply to horizontal terminations.

- Standard Horizontal Terminal
- 14" Snorkel, Horizontal Terminal
- 36" Snorkel, Horizontal Terminal
- Vertical Terminal

STANDARD HORIZONTAL TERMINAL

All horizontal terminations require a minimum of 24" of vertical flue measured from the top of the stove.

SNORKEL TERMINAL (14" OR 36")

For installations close to the ground you must use a snorkel (extended terminal) that has the vertical rise built into it. The 36" snorkel is designed for below grade installation. **WARNING:** Direct vent terminals will not be recessed into a wall or siding.

VERTICAL TERMINAL

Vertical terminals are measured from the top of the stove and can be no more than a maximum of 34 feet from stove to flue cap. Where floors or attic space are penetrated by chimney vent pipe, safety requires that a round support box/fire stop be installed to ensure minimum clearances to any combustible material is maintained.

CHIMNEY PIPE

When planning the installation, it is necessary to select the proper length of vent pipe for a particular requirement. The Venting Graphs provided on the following pages will aid the installer in determining the proper relationship between vertical and horizontal side wall venting. These Venting Graphs should assist the installer in determining the various vent pipe lengths allowed for a specific installation. It is also important to note the wall thickness. Select the amount of vertical rise desired for "vertical -to- horizontal" type installations. To determine the length of a pipe required for vertical installation, measure the distance from the application flue outlet to ceiling, the ceiling thickness, the vertical rise in an attic, or second story, and allow for sufficient vent height above the roof-line. For two story applications, fire stops are required at each floor level. If an offset is needed in the attic, additional pipe and elbows will be required.

STANDARD HORIZONTAL VENT

STEP 1. Set the gas appliance in the desired location. Check to determine if wall studs are in the way where the venting system is to be attached. If wall studs become obstructions to venting, adjust the appliance location, if possible, to minimize the requirement to cut wall studs.

STEP 2. All direct vent chimney pipe and fittings are designed with special twist-lock connections. To allow easy connection to the venting system, a twist lock adapter has been built into the Bayvue DV. Assemble the desired combination of black pipe and elbows to the appliance adapter with pipe seams oriented towards the wall or floor, as much out of view as possible.

NOTE (1) Four indentations, located on the female ends of pipes and fittings, are designed to slide straight into the male ends of pipes and fittings. Orient the four pipe indentations to match the four entry slots on the male ends of the pipe. Push the pipe sections together. Twist-lock one section clockwise approximately one-quarter turn, until the two sections are fully locked. The female locking lugs will not be visible from the outside on the black pipe or fittings. Locate them by examining the inside of the female ends.

NOTE (2) Horizontal vent runs must be supported every three feet with wall straps. All intake air seams, including elbows, are required to be sealed with high temperature 600°F rated silicone sealant or equivalent.

STEP 3. With the adapter and pipe attached to the stove, slide the stove into its correct location, and mark the wall for a 10" x 10" square hole. The center of the square hole should line up with the centerline of the horizontal pipe. Cut and frame the 10" square hole in the exterior wall where the vent will be terminated. If the wall being penetrated is constructed of non-combustible material, i.e. masonry block or concrete, a 7" diameter hole is fine.

NOTE (1) The horizontal vent must rise a 1/4" for every 1 foot of run towards from the appliance to the termination. Never allow any vent to run downward from the stove. This will create high temperature pockets and will create the potential for a house fire.

NOTE (2) The location of the horizontal vent termination on an exterior wall must meet all local and national building codes, and must not be easily blocked or obstructed.

NOTE (3) Install a two-piece wall thimble (wall penetration heat shield) in the 10" x 10" square hole.

STEP 4 Position the horizontal vent termination in the center of the 10 inch square hole. Attach the horizontal vent termination to the exterior wall with the four wood screws provided as shown in FIGURE 13. Before attaching the Vent Termination to the exterior wall, run a bead of non-hardening mastic around its outside edges. This mastic will provide a weather seal between the horizontal vent termination and the exterior wall. The arrow on the horizontal vent cap should be pointing up. Ensure that proper clearances to combustible materials are maintained in all installations.

NOTE (1) The four wood screws provided should be replaced with appropriate fasteners for stucco, brick, concrete, or other types of sidings.

NOTE (2) For buildings with vinyl sidings, a Vinyl Siding Standoff (Part 950), should be installed between the vent cap and the exterior wall. . Attach the Vinyl Siding Standoff to the Horizontal Vent Termination. The Vinyl Siding Standoff prevents excessive heat from overheating the vinyl siding or the framing material underneath.

STEP 5 Before connecting the horizontal run of vent pipe to the vent termination, slide the black decorative wall thimble cover over the vent pipe.

STEP 6 Position the appliance and vent against the wall. Insert the vent pipe into the vent cap assembly. It is important that the vent pipe extend into the vent cap sufficient distance so as to result in a minimum pipe overlap of 1-1/4". Secure the connection between the vent pipe and the cap by attaching the two sheet metal strips extending from the vent cap assembly into the outer wall of the vent pipe. Use the two sheet metal screws to connect the strips to the pipe section. Bend any remaining portion of the sheet metal strip back towards the vent cap, so it will be concealed by the decorative wall thimble cover. Refer to FIGURE 14.

STEP 7 Slide the decorative wall thimble up FIGURE 16 to the wall surface and attach with screws provided. Apply decorative plated trim if desired as shown in FIGURE 15.

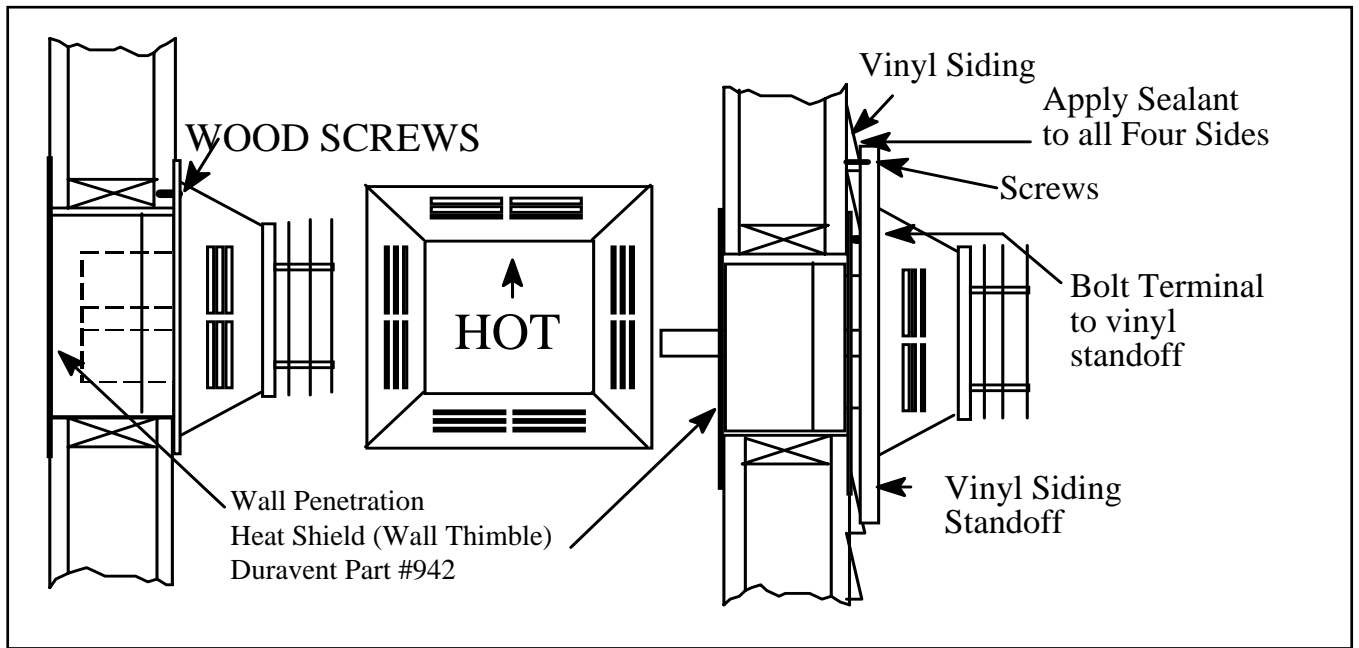

FIGURE 13: HORIZONTAL VENTING

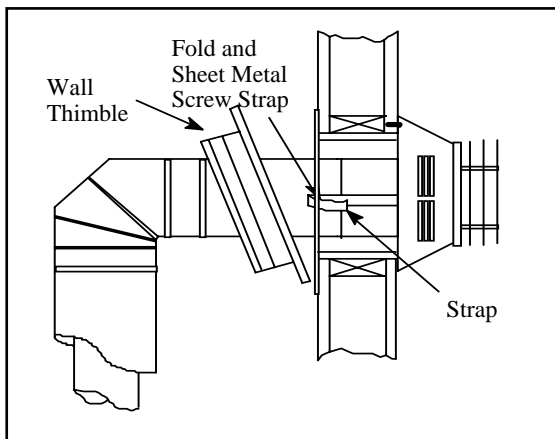

FIGURE 14: HORIZONTAL VENT

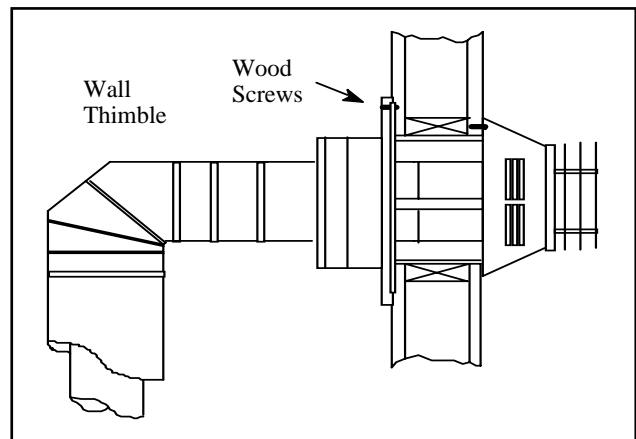

FIGURE 15: DECORATIVE TRIM

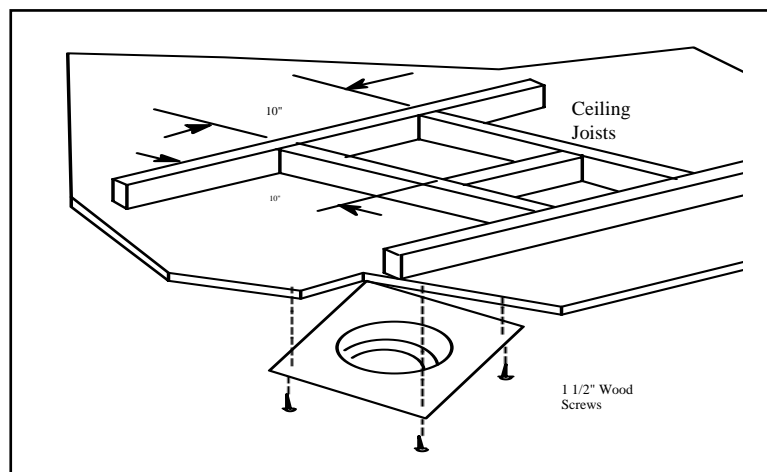

FIGURE 16: ROUND SUPPORT BOX/WALL THIMBLE

VERTICAL AND HORIZONTAL VENT

STEP 1. Determine the amount of horizontal run for a specific installation. Note the minimum vertical run and ensure it is met for a specific application as shown in FIGURE 17 below.

STEP 2. FIGURE 18 or 19 provides the minimum vertical rise required for a specific horizontal run

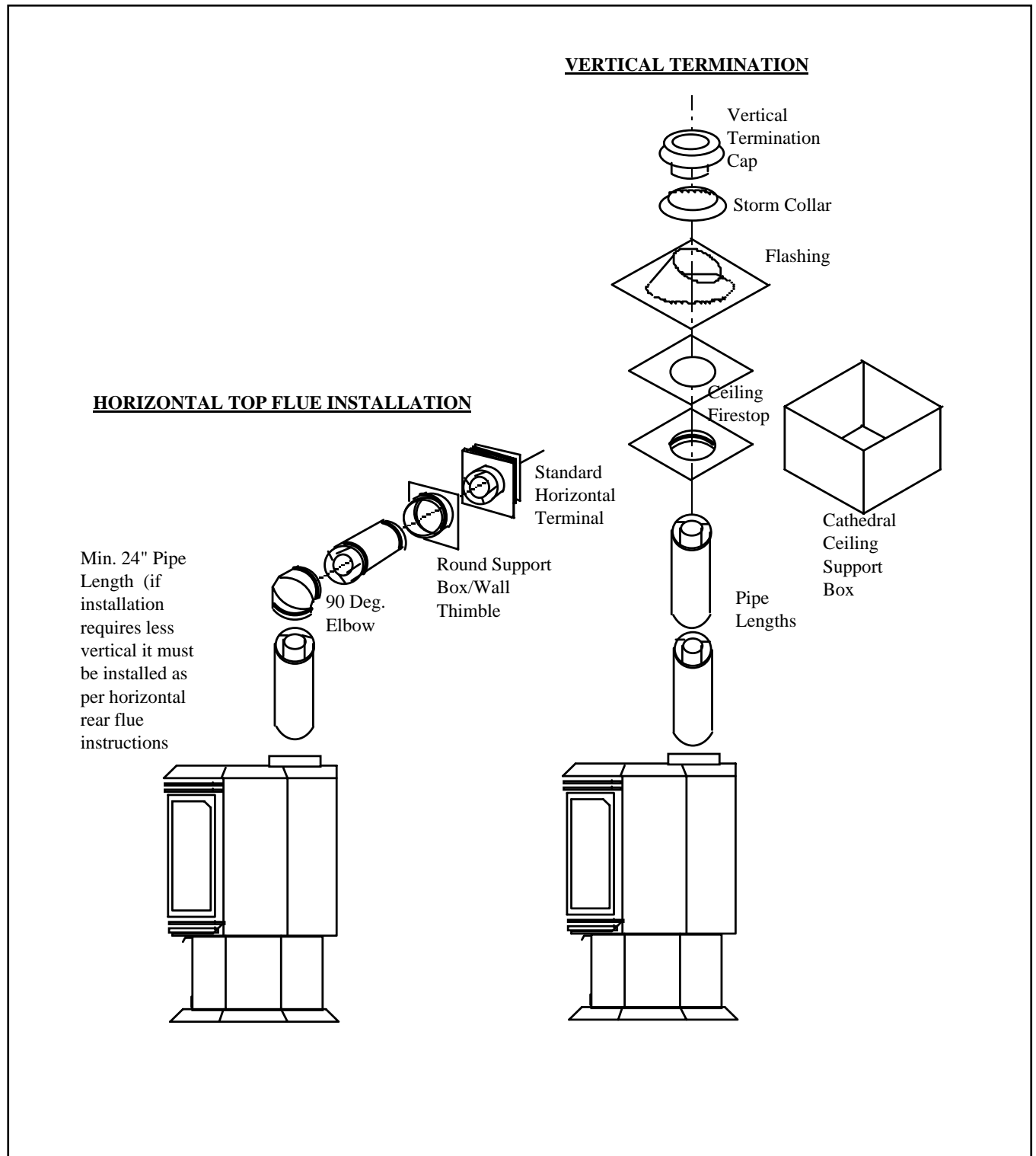

FIGURE 17: HORIZONTAL & VERTICAL VENT SYSTEM

VENT GRAPHS

Vent graphs are provided to assist the certified installer in determining the correct horizontal and vertical lengths of chimney pipe to be utilized for both a specific application and the specific fuel that will be used with a specific Bayvue DV model fireplace. Note: The Bayvue DV 46 and DV 30 have separate vent charts both per model and type of fuel being used. Ensure that the correct Chart is referenced during installation planning.

1. Determine which fuel graph chart is to be used. (Natural Gas or Propane)
2. Determine the height from the top of the stove to the 7" elbow. Draw a horizontal line until it intersects with the slanted graph line.
3. From the point of this intersection, draw a vertical line to the bottom of the graph.
4. Select the indicated dimension, and position the unit in accordance with the same.

Example 1: (Natural Gas Graph DV 46) If the vertical dimension from the top of the stove is 7 feet, the horizontal run to the outer wall flange must not exceed 9 feet.

Example 2: (Propane Gas Graph DV 46) If the vertical dimension from the top of the stove is 21 feet, the horizontal run to the outer wall flange must not exceed 8 feet.

FIGURE 18: BAYVUE DV VENT GRAPHS, MODEL DV 46

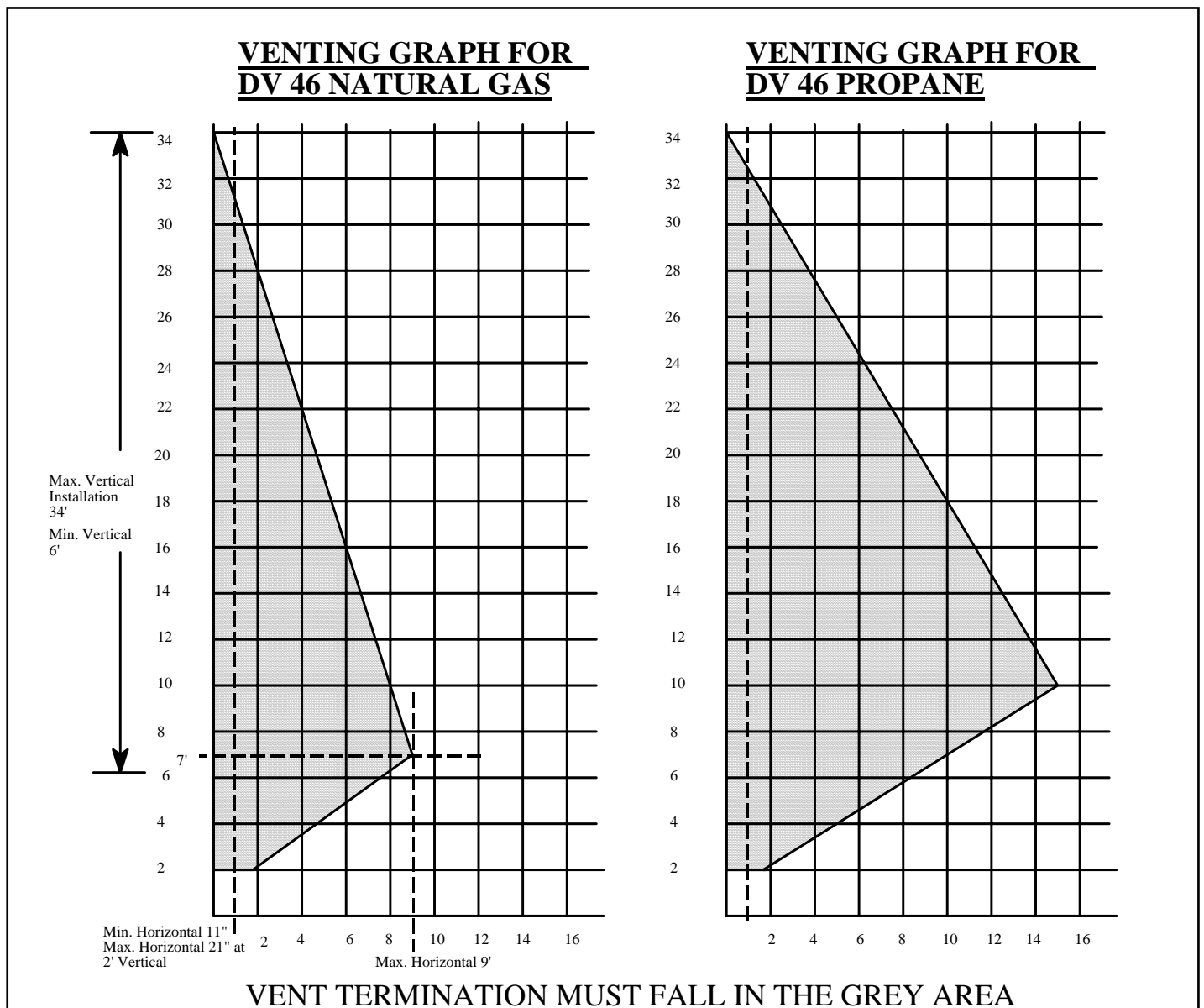

VENT GRAPH (cont'd)

Note: Maximum propane horizontal vent run is 13' (3960mm) when the vertical vent rise is 10' (3048mm)

Note: Minimum vertical rise is 2' (908 mm)

Note: Minimum horizontal run is 11" (279mm) on a vertical to horizontal installation.

Note: Minimum wall thickness 4" (100mm)

Note: Maximum wall thickness 20" (508mm).

FIGURE 19: BAYVUE DV VENT GRAPHS, MODEL DV 30

VENTING GRAPH FOR DV 30 NATURAL GAS

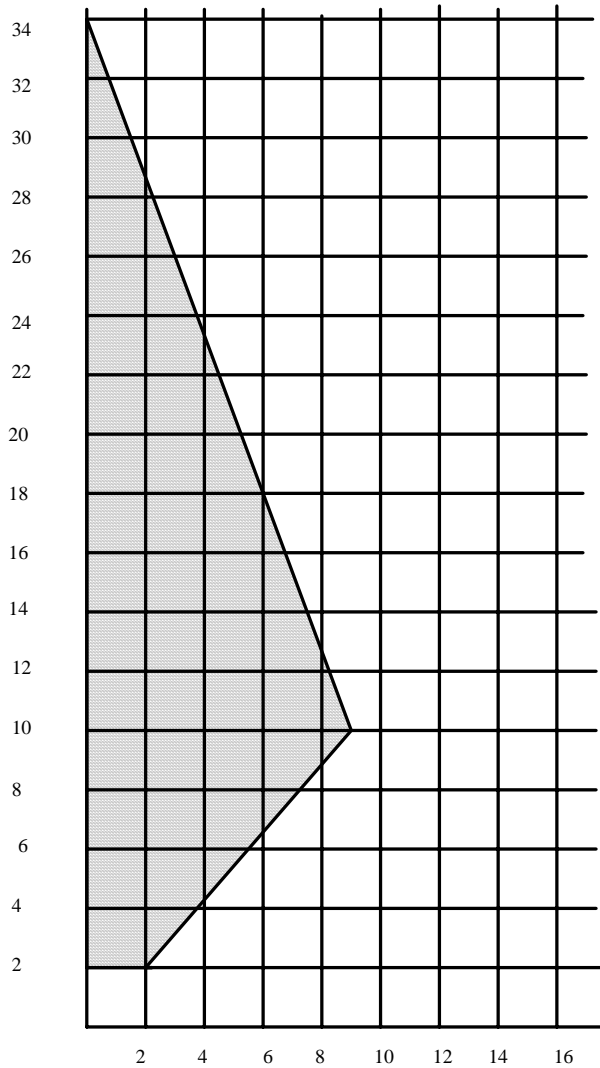

VENTING GRAPH FOR DV 30 PROPANE

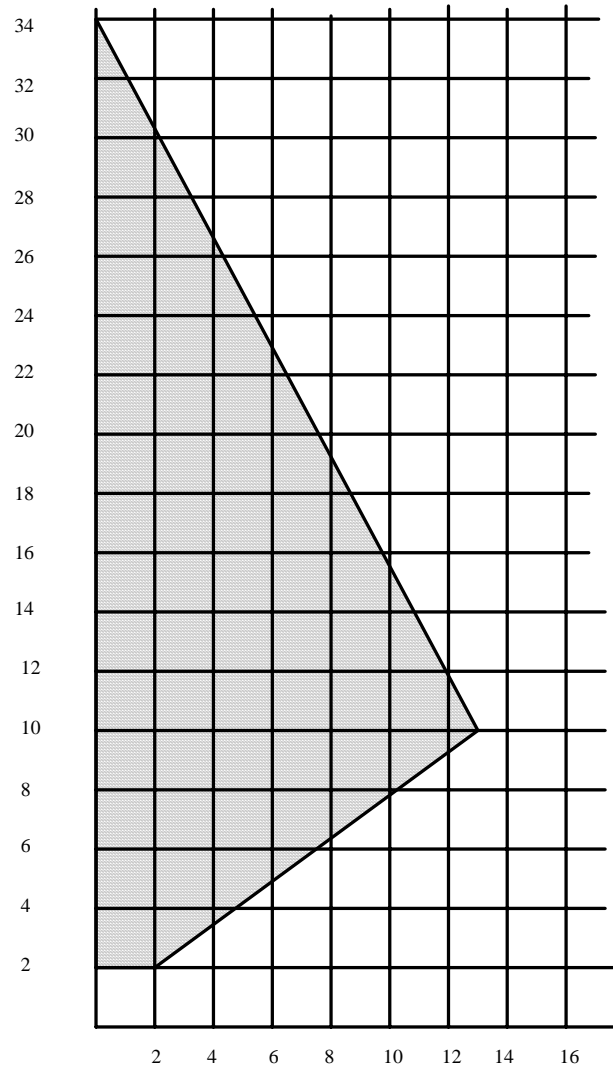

VENT TERMINATION MUST FALL IN THE GREY AREA

A vent shall not terminate:

- A. Within six feet (1.8 meters) of a mechanical air supply inlet to a building.
- B. Above a utility meter within three feet (1 meter) horizontally of its vertical center line.
- C. Within six feet (1.8 meters) of any gas service regulator vent outlet.

- D. Within twelve inches (305 millimeter) of an unventilated soffit.
- E. Less than twelve inches (305 millimeter) above grade level from the bottom of the vent terminal.

A vent shall not terminate directly above a side-walk or paved driveway which is located between two single family dwellings and serves both dwellings.

Clearance of 12" (30cm) minimum is only permitted if the veranda, porch, deck, or balcony, is fully open on a minimum of 2 sides beneath the floor.

For USA installations, follow current National Fuel Gas Code ANSI Z 223.1 with reference to NFPA 54 (natural gas) or NFPA 58 (propane.) In CANADA refer to CGA B149 Installation Codes Note: Local Codes or Regulations may require different clearances.

SNORKEL VENT

For installations requiring a vertical rise on the exterior of the building, follow the same installation procedures as used for standard Horizontal Terminations up to STEP 3, then continue with STEP 4 below.

If the Snorkel Termination must be installed below grade, use the 36" snorkel. Proper drainage must be provided to prevent water from entering the Snorkel Termination.

Note: The maximum 90 degree elbows permitted per side wall (horizontal) installation is one. An additional 45 degree is permitted for corner installation.

VERTICAL VENT

Vertical termination assumes no horizontal run of exhaust pipe is involved in the venting system. The maximum vertical rise allowed for the Bayvue DV appliance is 34 feet when measured from the top of the appliance to the bottom of the Flue Cap. The maximum number of 45 degree elbows permitted for a vertical installation is four elbows. Installation of the four elbows does not decrease the allowable vertical rise of the Bayvue DV appliance.

STEP 1 Do not pack air spaces between combustibles and the vent pipe with insulation.

STEP 2 Set the gas appliance in the desired location. Drop a plumb bob down from the ceiling to the position of the appliance flue exit, and mark the location where the vent will penetrate the ceiling. Drill a small hole at this point. Next, drop a plumb bob from the roof to the hole previously drilled in the ceiling. Mark the spot where the vent will penetrate the roof. Determine if ceiling joists, roof rafters, or other framing will obstruct the venting system. You may wish to relocate the appliance to avoid cutting load-bearing members.

STEP 3 To install the round support box/wall thimble in a flat ceiling, cut a 10" square hole in the ceiling, centered on the hole drilled in STEP 2. The hole should be of sufficient size to meet the minimum requirements of 1" to combustibles. Frame the hole as shown in FIGURE 16.

STEP 4 If the twist-lock adapter has not been installed on the stove by the manufacturer; install it now in accordance with the stove instruction manual.

STEP 5 Assemble the desired lengths of black pipe necessary to reach from the appliance adapter up through the round support box. Insure that all pipe and elbow connections are in their fully twist-locked position.

STEP 6 Continue to assemble lengths of pipe and elbows necessary to reach from the ceiling support box up through the roof line. Galvanized pipe and elbows may be utilized in the attic, as well as above the roof line. The galvanized finish is desirable above the roof line, due to its higher corrosion resistance.

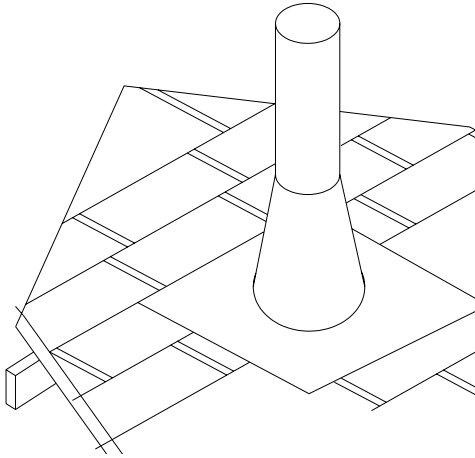

ROOF PITCH	FEET	METERS
Flat to 6/12	1	0.3
7/12 to 9/12	2	0.6
10/12 to 12/12	3	1.2
13/12 to 16/12	6	1.8
17/12 to 21/12	8	2.4

NOTE: For direct vent appliances, the vent/air intake termination clearances above the high side of an angled roof are listed above.

FIGURE 20: CHIMNEY VENT

STEP 7 Slip the flashing over the pipe sections protruding through the roof. Secure the base of the flashing to the roof with roofing nails. Insure the roofing material overlaps the top edge of the flashing to the roof with roofing nails. Insure the roofing material overlaps the top edge of the flashing as shown. Verify that you have at least 1" clearance to combustibles at the roof line.

STEP 8 Continue to add pipe sections until the height of the vent cap meets the minimum building code requirements. Note that for steep roof pitches, the vent height must be increased. In high wind conditions, nearby trees, adjoining roof lines, steep pitched roofs, and other similar factors can result in poor draft, or down-drafting. In these cases, increasing the vent height may solve this problem.

STEP 9 Twist lock the vent cap onto the top of the chimney system.

Note (1): For multi-story vertical installations, a ceiling fire stop (Part 963) is required at the second floor, and any subsequent floors. The opening should be framed to 10" x 10" inside dimensions. Any occupied areas above the first floor, including closets and storage spaces, which the vertical vent passes through, must be enclosed. The enclosure may be framed and sheet-rocked with standard construction materials, leaving a 1" minimum clearance between the outside of the vent pipe, and the combustible surfaces of the enclosure. Do not fill any of the required air spaces with insulation.

Note (2): For direct vent appliances, the vent/air intake termination clearances above the high side of an angled roof are as follows:

CATHEDRAL CEILINGS

STEP 1 Follow installation Steps 1 and 2 under Vertical Terminations.

STEP 2 Using a plumb bob mark the centerline of the venting system on the ceiling. Drill a small hole through the ceiling and roof at this point. From the roof, locate the drill hole and mark the outline of the cathedral ceiling support box.

- STEP 3** Remove shingles or other roof covering as necessary to cut the rectangular hole for the support box. Cut the hole 1/8" larger than the support box outline.
- STEP 4** Lower the support box through the hole in the roof until the bottom of the support box protrudes at least 2 inches below the ceiling. Align the support box in place through the inside walls and into the roof sheathing.
- STEP 5** Using tin snips, cut the support box from the top corners down to the roof line, and fold the resulting flaps over the roof sheathing. Before nailing it to the roof, run a bead of non-hardening mastic around the top edges of the support box, to make a seal between the box and the roof. Clean out any combustible material from inside the support box.
- STEP 6** Complete the cathedral ceiling installation by following the same procedures outlined in Steps 4 through 9 for vertical terminations.

MAINTENANCE

The frequency of performing fireplace maintenance depends on site-specific conditions and the frequency of homeowner use of this product. Country Flame recommends that a certified service technician perform an annual check-up on an appliance prior to the start of each heating season. Follow the general guidelines provided below for each specific maintenance task. If there are any questions about maintenance or proper service, contact the local Country Flame dealer or a certified service technician for clarification of any issue.

IMPORTANT: TURN OFF THE FIREPLACE AND SHUT OFF THE GAS BEFORE SERVICING ANY FIREPLACE.

SPECIFIC TASKS

CLEANING BURNERS AND CONTROLS

FREQUENCY: Once during annual inspection.

PERFORMED BY: Qualified service technician.

TASK PERFORMED: Clean the control compartment. Remove and clean logs (careful not to damage ceramic logs). While logs are removed, clean and inspect 3 burners, inspect and clean pilot assembly, and inspect and clean surrounding burner area.

REPLACE OLD EMBERS

FREQUENCY: Once during annual inspection.

PERFORMED BY: Qualified service technician.

TASK PERFORMED: Replace ember material with new ember material. Additional ember material can be purchased from a local authorized Country Flame Dealer. (Only use genuine Country Flame ember material)

CHECK FLAME AND PILOT

FREQUENCY: Periodically.

PERFORMED BY: Qualified service technician or homeowner.

TASK PERFORMED: Visually inspect the three burner's flame height and burn patterns. The front burner flame will be barely visible through the glowing embers. The middle and back burner flames are steady and not lifting or floating from away from the burner surfaces. Refer to FIGURE 5d for a picture representation of the proper flame with logs and embers installed. Visually inspect that the pilot light is burning with four blue flame nodes, FIGURE 21, protruding from the pilot flame diffuser, FIGURE 21, Item B. There should be no sputter or blockage of any of the pilot flame or its four flame nodes. There should be a blue flame surrounding the outside edge of the pilot flame diffuser, FIGURE 21, Item B. In the event any abnormality is observed in the burner flame pattern or the pilot light flame pattern, contact a local authorized Country Flame Dealer or certified technician.

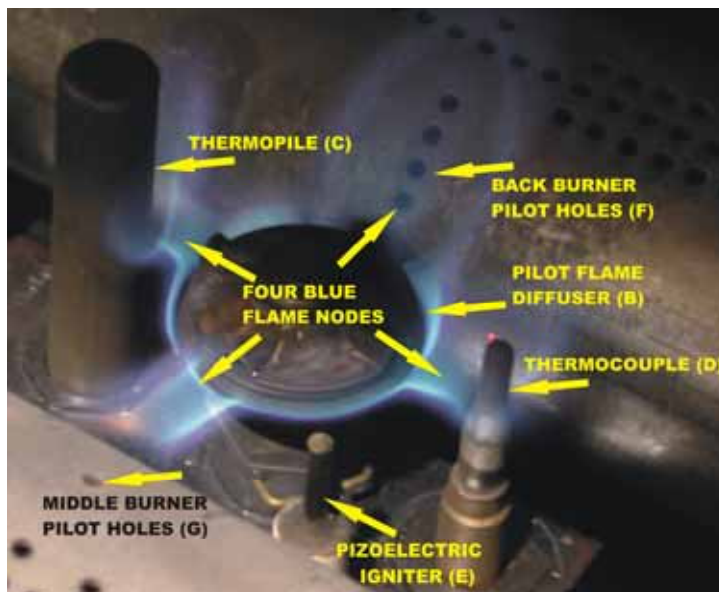

FIGURE 21: STANDING PILOT

WARNING: DO NOT ATTEMPT TO CLEAN GLASS UNTIL APPLIANCE IS COOL

GLASS CLEANING

FREQUENCY: Before the first use and after first four hours of use the glass should be cleaned; thereafter, clean as necessary.

PERFORMED BY: Homeowner.

TASK PERFORMED: Remove the door assembly by unhooking the four locks (2 locks on each side). Use a household glass cleaner or a Hearth Industry approved gas stove glass cleaner. Replace the door assembly and close the four locks to properly seal the door to the body of the Bayvue DV.

WARNING: DO NOT USE ABRASIVE CLEANERS ON GLASS SURFACE

CHECK VENT SYSTEM

FREQUENCY: Once during annual inspection. See General Inspection for additional requirements.

PERFORMED BY: Qualified service technician or homeowner.

TASK PERFORMED: Check complete vent system for corrosion, moisture problems, pin holes or broken seals. Remove chimney cap and inspect vent and cap for debris. Ensure clean and open vent system.

GLASS-CERAMIC SPECIFICATIONS

KERA LITE® glass-ceramic is specially manufactured for use in high temperature applications. This glass-ceramic has a thermal endurance far exceeding that of normal tempered glass. KERA LITE® is designed to operate at temperatures ranging from -400°F to +1400°F. Despite its superior thermal properties, KERA LITE® stove windows should be treated with care. This glass-ceramic can still be scratched or broken by mechanical abuse. When cleaning the window, use only non-caustic, non-abrasive cleaners. Country Flame gas fireplace doors use a KERA LITE® glass-ceramic that is 0.197 inches thick +/- 0.008 inches. Country Flame custom cuts each KERA LITE® glass at its factory to fit the fireplace door. If problems occur or should the glass-ceramic ever need replacement, contact Country Flame or a local authorized dealer for assistance. The glass-ceramic specifications are as follows:

Manufacturer
Window Type

Euro Kera
Glass-Ceramic, Kera Lite®

GLASS REPLACEMENT

1. Turn off gas valve.
2. Unlock four door latches (2 each side), refer to door installation section and FIGURE 23.
WARNING: Once door latches are unhooked, nothing holds door assembly to Bayvue DV. Do not let the door assembly drop, handle with care.
3. Remove the door assembly from the Bayvue DV guide pins and lay it on a padded flat surface.
4. From the inside of the door remove the door rope gasket, FIGURE 22, left view, Item E. Undo twenty #6 nuts and four #10/32 screws, FIGURE 22, right view, Item J that holds glass retainer strips in place. Store all loose parts in a safe location as they will be required during reinstallation. Remove the glass retainers, FIGURE 22, right view, Item I. **WARNING:** Broken glass is extremely sharp. Use extreme caution. Use leather gloves and wear safety glasses when removing broken glass.

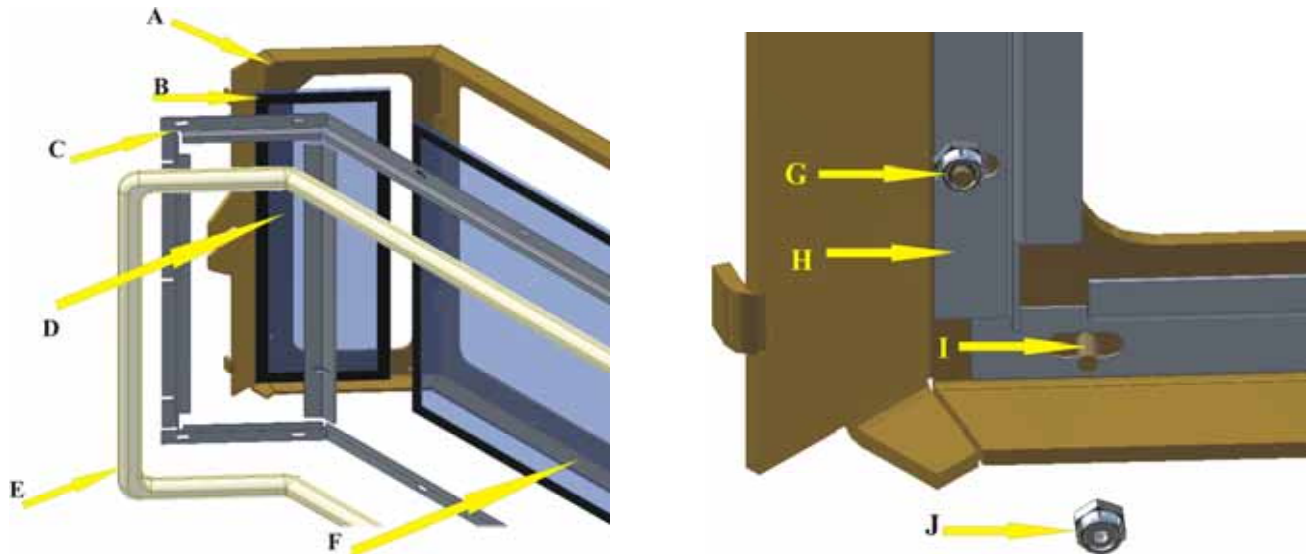

FIGURE 22: GLASS REPLACEMENT

GASKET SPECIFICATIONS

<u>GASKET</u>	<u>LENGTH</u>	<u>QUANTITY</u>	<u>DESCRIPTION</u>
<u>BAYVUE DOOR SYSTEM</u>			
Fiberglass tape side glass	36"	2	¾" by 1/16" fiberglass tape
Fiberglass tape center glass	41"	1	¾" by 1/16" fiberglass tape
Rope gasket, front door	88"	1	¾" diameter rope, high density

5. Clean the doorframe as necessary to prepare for new glass. All old glass tape, broken glass, and debris should be removed from the frame in order for the new glass and glass tape to fit properly in place.
6. Position and install the three glass panels, FIGURE 22, left view, Item D and Item F in the doorframe. The third glass panel is not shown in FIGURE 22. All glass comes pre-taped with fiberglass insulation, FIGURE 22, left view, Item B.
7. Set glass retainers, FIGURE 22, right view, Item H in place over the glass. Reinstall twenty #6 nuts and four #10/32 screws, FIGURE 22, right view, Item J onto Item I to hold retainers in place. DO NOT over tighten.
8. Install door rope gasket, FIGURE 22, left view, Item F, using small amount of rope cement to hold rope gasket in place.
9. Reinstall assembly, FIGURE 24 to stove body. Close door latches, securing assembly to Bayvue DV.
10. The door assembly is a sealed unit. Refer to door seal section. Reread test procedures and check door seal. Perform test seal procedure to ensure door assembly fits properly to Bayvue DV body. Contact a local authorized Country Flame Dealer or a certified professional if there are any issues with the seal.

WARNING: THIS PRODUCT IS A SEALED APPLIANCE. THE DOOR ASSEMBLY MUST SEAL AGAINST STOVE BODY FOR PROPER OPERATION. NEVER OPERATE THE STOVE WITH BROKEN GLASS OR WITH THE DOOR OPEN. ANY LEAKAGE MAY CAUSE DANGEROUS INDOOR AIR POLLUTION. DO NOT ABUSE DOOR GLASS, SUCH AS SLAMMING THE DOOR OR STRIKING THE GLASS.

WARNING: USE COUNTRY FLAME REPLACEMENT PARTS (EXACT PART NUMBERS). REPLACE PARTS AS COMPLETE ASSEMBLY WHERE NECESSARY. REFER TO GLASS CLEANING SECTION.

GENERAL VENT INSPECTION

Inspect the venting system periodically. Additional areas to inspect are as follows:

1. Check areas of the venting system which are exposed to the elements for corrosion. These will appear as rust spots or streaks, and in extreme cases, can be holes. These components must be replaced to ensure the integrity of the system and the safety of the homeowner.
2. Remove the chimney cap and shine a flashlight down the vent. Remove all debris, bird nests, or other foreign material found in the vent system.
3. Check for evidences of excessive condensate, such as water droplets forming in the inner liner, and subsequently dripping out of vent joints. Continuous condensate can cause corrosion of caps, pipe and fittings. Condensation may be caused by having excessive horizontal runs, too many elbows, and exterior portions of the system being exposed to cold weather. Consult a certified professional to correct.
4. Inspect joints, to verify that no pipe sections or fittings have been disturbed or consequently loosened. Also check mechanical supports such as wall straps or plumbers' tape for proper integrity/support.
5. For all direct vent systems, proper re-assembly and resealing of the vent-air intake system is mandatory. If the vent-air system is disassembled for any reason, reinstall each part per instruction provided for the initial installation.

GENERAL CLEANING

General cleaning of the appliance should be completed routinely to remove all dust, lint, or other debris that has built up during non-use in the off season. The three burners should be cleaned per specific tasks listed in this manual. The burners can be blown out with dry air or be vacuumed to remove dust or other debris. If any burners look to be damaged or degraded in appearance, contact a certified professional to verify their working order.

No lubrication of any part is required in the Bayvue DV appliance. It is recommended that at a minimum, annual inspection of the venting system be conducted by a certified professional. At no time should the combustion air or ventilation air of this appliance be allowed to become obstructed. Free airflow is crucial to the proper operation of this appliance. The pilot and burner should be checked for proper flame pattern. Flame patterns should not appear to be suspended about the pilot tube or the burners. Nor should the pilot or burner flame appear lifeless or smoking in its burn pattern. Have the operational burn patterns checked by a certified professional in the event there is any question about gas burn patterns. Do not use this appliance if any part or component of this appliance has ever been under water. Immediately call a certified professional to inspect or replace any part or control system that has been under water.

GENERAL SAFETY

- Always shut off the gas supply and allow the heater to cool down before attempting any service work.
- Always check for leaks, after servicing.
- Always check for correct combustion and ventilation air flow after performing any service.
- Always make sure the heater is away from any combustible or flammable materials.
- Always ensure proper re-assembly and re-sealing of all vent-air intake parts. If any part of the system is disassembled, reinstall those parts per the instructions provided in this manual.

GENERAL PERIODIC INSPECTIONS

Check the venting system annually and make sure the system is clear of any debris.

Check flame patterns periodically.

Allow 15 minutes for the flame to reach maximum color and height.

CLEANING A PAINTED SURFACE

Occasionally dry rag dust to keep the painted surface looking new. Paint can be touched up as needed. Clean the areas to be painted with fine steel wool. Remove all trim or cover all trim and controls with masking tape. Then, touch up the stove with Stove Bright® high temperature stove paint.

CLEANING PLATED SURFACES

When cleaning plated trim, special care needs to be taken to avoid damage. Do not use chemical or abrasive cleaners. Wipe only with a very soft damp cotton cloth to maintain original brilliance. CAUTION: Vigorous wiping may remove or discolor the plated finish.

DOOR INSTALLATION

The door is installed or removed by closing or opening four door latches, two on each side of the Bayvue DV. FIGURE 23 shows a split view of the door latch and door guide system. FIGURE 23 left view; Item A shows the top door latch in its closed position. FIGURE 23 right view; Item A shows the bottom door latch in its open position. Each latch has an adjustment screw to ensure a good tight latch can be obtained which in turn will ensure proper sealing of the door to the Bayvue DV. FIGURE 23, Item B shows the guide pin that is located on each side of the Bayvue DV to assist in proper location of the door assembly. Never operate the stove with the door open. Correct Bayvue DV operation requires the door assembly be mounted to the stove and locked during all operations, except during maintenance.

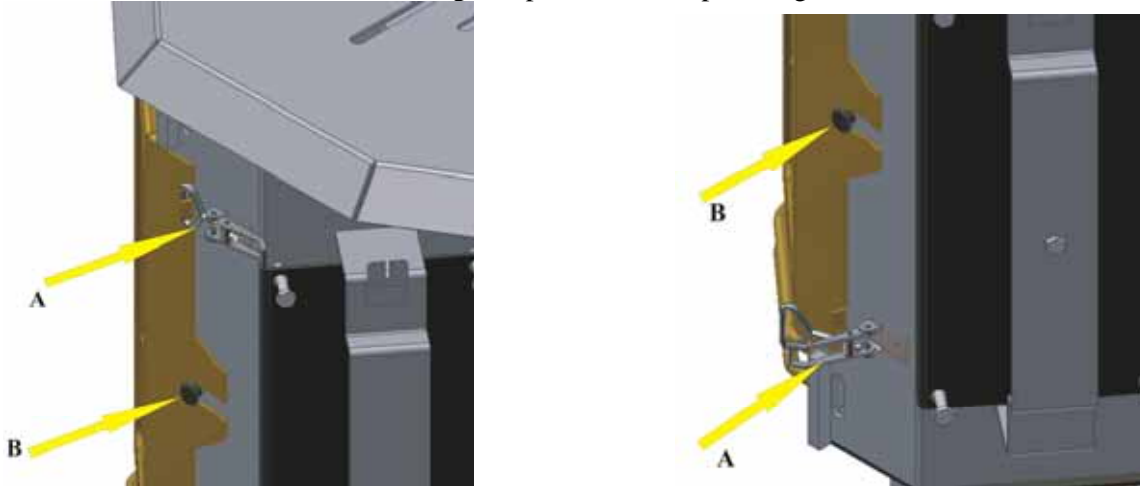

FIGURE 23: DOOR INSTALLATION

DOOR SEAL

Always open the two magnetically latched side panels before opening the large viewing door. Test for a good seal around the face of the door to the body of the appliance. To test the seal, place a piece of paper between the body of the stove and the door, close and latch the door. Try pulling the paper from the door. If the paper is easily removed, tighten the latches and secure the latch with the locking nuts. Once adjustments have been made, test the door seal again. The test should be tried at several locations around the doorframe. If the paper is easily pulled out no matter where the test is taken, it is probably time to replace the heavy door rope gasket shown in FIGURE 24 below. If there is any concern about a proper seal or the condition of the door rope gasket or glass tape, contact a local authorized Country Flame Dealer or a certified technician for assistance.

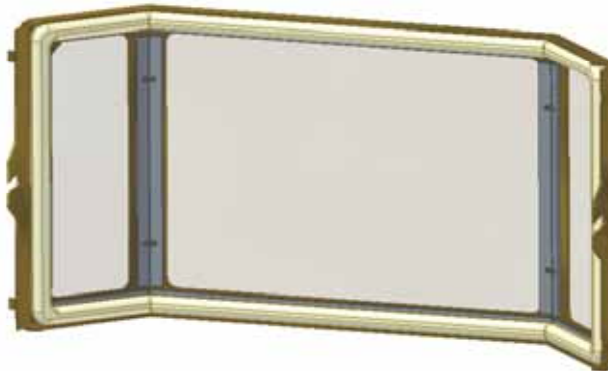

FIGURE 24: DOOR ASSEMBLY

MAIN ORIFICES

FIGURE 25, left view, illustrates the front burner spud orifice (Item A) unthreaded from the orifice holder (Item B). Do not over tighten the orifice spud. Do not leave the orifice spud finger tight as gas may leak from the loose fitting. Note that the front, middle, and rear spud orifices are identified as Item A. FIGURE 25 also shows the pilot assembly (Item C) for reference purposes.

FIGURE 25, right view, shows the burner assembly with a partial view of all three burners; front burner (Item D), middle burner (Item E), and the rear burner (Item F) installed. Be careful, when removing burners. The front burner is uniquely different but the middle and rear burner look very similar. When any one or all of the burners are removed, ensure they are marked from the spot they were taken and returned to the same position. The burners are NOT interchangeable and must be placed in the proper position to prevent sooting from occurring and to ensure proper burning.

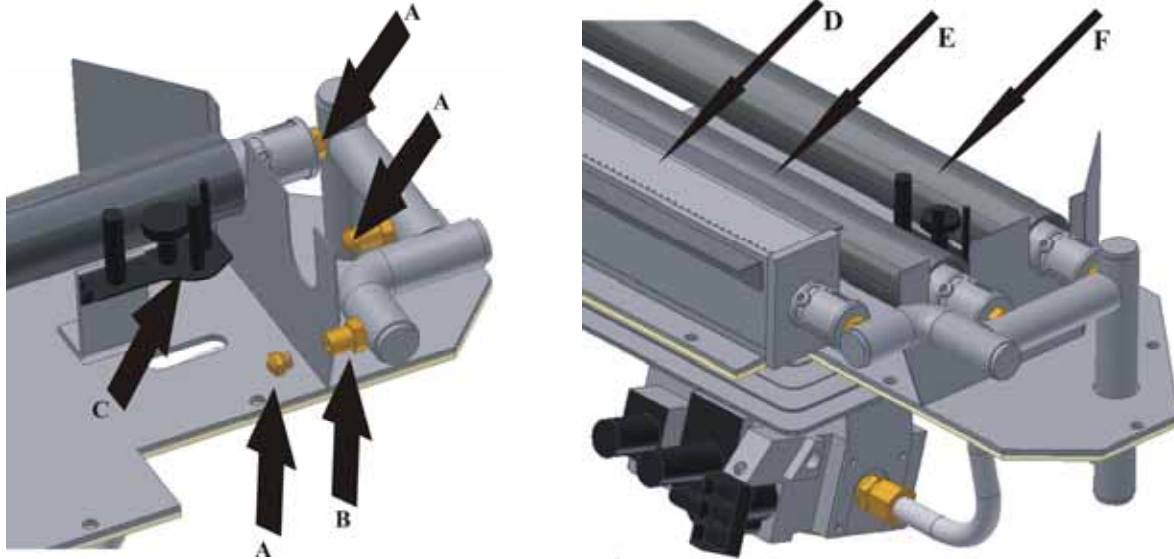

FIGURE 25: BURNER ASSEMBLY

GAS FLAME INSPECTION

The flames will be blue during the first 5 minutes or so but over the period of 15 minutes they will gradually turn yellow. Flame intensity and the glowing logs vary with the specific type of fuel and venting conditions. Refer to FIGURE 5d for a picture that shows a proper flame for natural gas.

IMPORTANT INFORMATION: IT IS NORMAL FOR GAS PRODUCTS, FABRICATED FROM STEEL, TO GIVE OFF SOME EXPANSION AND/OR CONTRACTION NOISES DURING THE START UP OR COOL DOWN CYCLE. SIMILAR NOISES ARE FOUND WITH YOUR FURNACE HEAT EXCHANGER OR CAR ENGINE.

RELIEF VALVE INSPECTON

Relief valves are located on the left and right side of the Bayvue DV. In order to inspect these relief valves, the magnetically latched side doors (left and right side) will need to be opened. FIGURE 26, Item A, shows a relief valve located on the right side of the appliance. NOTE: The right side magnetically latched door is not shown for clarity. A relief valve must be free to move in a direction perpendicular to the body of the appliance. FIGURE 26, Item C shows the normal direction of travel of the relief valve. A spring provides tension to hold the relief valve against the body of the stove. Relief plates should be free to slide on the tracks provided, shown in FIGURE 26, as Item B in order to relieve any pressure buildup in the combustion chamber. To test the relief valve, apply light lifting pressure, in the direction of Item C, to ensure a relief plate moves freely. Once the pressure is removed, a relief plate should return to the normal position against the stove body. If there is any question about the proper operation of the relief valve, contact a local authorized Country Flame Dealer or a certified service technician.

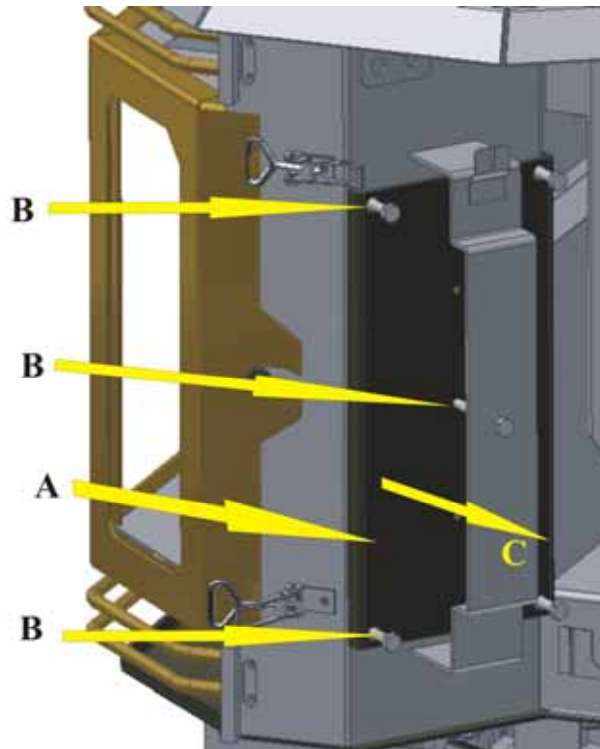

FIGURE 26: RELIEF VALVE

SIT 820 NOVA mV GAS CONTROL VALVE

The 820 Gas Control Valve is shown below in FIGURE 27.

1. The left knob controls the ON/PILOT/OFF functions.
2. The right knob controls the manifold pressure to the burners and is labeled HI/LO.
3. There is a PILOT ADJSUT screw that should only be be adjusted by a certified technician.
4. The SIT 820 has an input pressure test port labeled IN.
5. The SIT 820 has an output pressure test port labeled OUT.

To use either of the pressure test ports to measure pressure requires test equipment and knowledge required by a certified service technician. Improperly adjusting the pilot adjust or the manifold pressure can cause damage to the SIT 820 control valve and should only be accomplished by a certified professional. For lighting instructions refer to the section on first fire in this manual or on the units control panel.

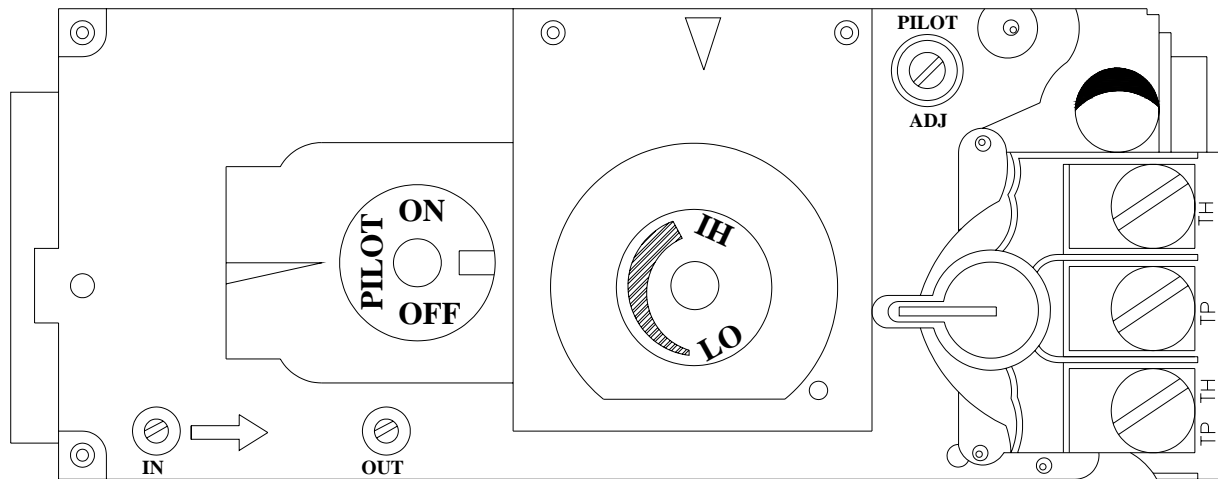

FIGURE 27: SIT 820 mV NOVA GAS VALVE

NOTE: TP stands for thermopile, TH for thermostat, and TP TH for thermopile and thermostat. See FIGURE 28.

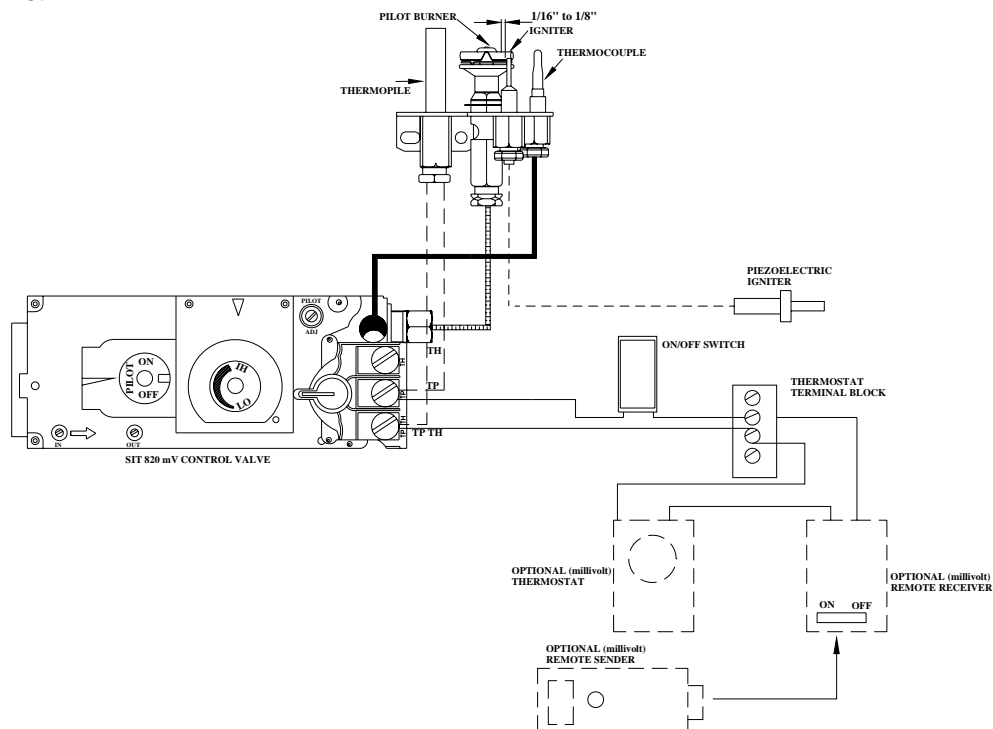

FIGURE 28: SIT 820 mV NOVA GAS VALVE WIRING DIAGRAM

WARRANTY

LIMITED LIFETIME WARRANTY FOR GAS HEATING APPLIANCES

Country Flame Technologies warrants a gas heating appliance to the original retail purchaser for the lifetime of the appliance, to be free from defects in workmanship. This warranty gives the original retail purchaser specific rights. Other rights may be available that vary from state to state or province to province.

This limited Lifetime Warranty covers items such as but is not limited to combustion chamber, heat exchangers, and the doorframe. Labor to repair or replace these parts is not covered.

All parts suspected of failure must be returned, at the original retail purchaser's expense, for inspection and replacement approval by Country Flame Technologies prior to repair or replacement. No repair or replacement will be honored without prior approval of Country Flame Technologies.

This Country Flame Technologies product must be installed by a competent, authorized service contractor. This product must be installed and operated at all times in accordance with this owner's manual, as well as in accordance with any and all applicable national codes, local codes, and gas supplier restrictions. Any alteration, willful abuse, accident, or misuse of the product shall void this warranty.

Any installation, construction, transportation, or other related costs or expenses arising from defective part(s), repair or replacement will not be covered by this warranty. Country Flame Technologies will not assume responsibility for any costs associated with the installation, construction, transportation, or other related costs or expenses arising from defective parts. Further, Country Flame Technologies has no control over the installation, construction, or transportation of this product and will not be responsible for any incidental, indirect, or consequential damages, except as provided by law.

All electrical components such as but not limited to blowers, wiring, switches, speed controls, thermo-disc switches, igniters, burners, and gas valves are covered under Country Flame Technologies one year warranty program.

Country Flame Technologies will not be responsible for any alteration to the unit which causes sooting that results in damage to the interior or exterior of the building in which this appliance is installed.

This warranty is void if the stove has been stored or operated in atmospheres contaminated by chlorine, fluorine, or other damaging chemicals. This warranty is void if the stove is subjected to prolonged periods of dampness or condensation, or there is any damage to the stove or other components due to water or weather damage which is the result of, but not limited to, improper chimney or venting installation.

This limited Lifetime Warranty does not extend to or include paint, glass, door gasket(s), glass gasket(s), log supports, embers, decorative grates or andirons or ceramic insulating materials.

The limited Lifetime Warranty does not cover installation or operational-related problems such as damage due to over firing (warped parts), downdrafts or spillage caused by environmental conditions, nearby trees, buildings, hilltops, mountains, inadequate venting or ventilation, excessive offsets, or negative air pressures caused by mechanical systems such as furnaces, fans, clothes dryers, etc.

This limited Lifetime Warranty does not apply to venting components, hearth components or other accessories used in conjunction with the installation of this product not manufactured by Country Flame Technologies.

This limited Lifetime Warranty is effective on all gas stoves sold after January 1, 2004 and supersedes any and all warranties currently in existence.

If any part of the stove becomes defective during the period of this warranty, send part or stove AND COPY OF INVOICE SHOWING DATE OF PURCHASE, freight prepaid to the address below.

Country Flame Technologies
900 George Street
Marshfield, Missouri, 65706
417-859-0990

TROUBLE SHOOTING GUIDE

SYMPTOM	PROBLEM	CORRECTIVE ACTION
Pilot will not light	No spark at the pilot burner	Check that the wire is connected to the push button igniter. Check if the push button igniter needs tightening. Replace pilot assembly if ceramic insulator is cracked or broken.
	Spark gap is incorrect	Spark gap should be 1/16" to 1/8" from the electrode tip and the pilot burner. Light the pilot with a match and adjust the electrode tip to the required spark gap and proper location.
	No gas at the pilot burner	Check that the manual valve(s) is (are) turned on. Check the pilot orifice for blockage. Replace the valve. Call the gas distributor.
Pilot goes out when the gas knob is released	Out of Propane	Fill the tank
	System is not correctly purged Out of Propane gas Pilot flame is not large enough Pilot flame is not engulfing the generator (thermocouple) Thermocouple shorting Faulty valve Faulty thermocouple	Purge the gas line. Fill the tank. Turn up the pilot flame. Gently twist the pilot head to improve the flame pattern around the generator (thermocouple). Clean the thermocouple. Replace valve. Replace thermocouple.
Pilot burning: no gas to main burner; gas knob "on"	Main burner is plugged	Remove stoppage in the orifice.
Main burner goes out; pilot stays on	Pilot flame is not large enough or not engulfing the thermocouple	Turn the pilot flame. Gently twist the pilot head to improve the flame pattern around the thermocouple.
Thermocouple Shorting	Clean thermocouple and valve terminals	Check that the thermocouple insulation is not frayed and grounding out on the fireplace housing or burner support.
Burner Flame yellow and lazy	Dirt in the burner orifice Wrong orifice Clogged flue Improper gas pressure	Remove and clean. Replace orifice. Clean flue. Adjust regulator.

TROUBLE SHOOTING GUIDE (cont'd)

SYMPTOM	PROBLEM	CORRECTIVE ACTION
Burner pops off	Dirt in the burner orifice Improper gas pressure	Remove and clean Adjust regulator
Flame in mixing tube	Dirt in burner orifice Improper gas pressure	Remove and clean Adjust regulator
Not heating properly (Not enough or too slow)	Dirt in the burner orifice Wrong orifice Too much draft Improper gas pressure Underrated Appliance	Remove and clean Replace orifice Check vent installation Adjust regulator Correct burner orifice size
Combustion Odors	Venting System not sealed	Call installer and do not fire unit.
Overheats	Dirt on Valve seat	Faulty control Replace control

PARTS LIST

PART NUMBER	DESCRIPTION
BV-3001	Burner Valve Assembly 30,000 BTUH - Natural Gas
BV-3002	Burner Valve Assembly 30,000 BTUH - Liquid Propane
BV-3003	Conversion Kit 30,000 BTUH - Natural Gas
BV-3004	Conversion Kit 30,000 BTUH - Liquid Propane
BV-4601	Burner Valve Assembly 46,000 BTUH - Natural Gas
BV-4602	Burner Valve Assembly 46,000 BTUH - Liquid Propane
BV-4603	Conversion Kit 46,000 BTUH - Natural Gas
BV-4604	Conversion Kit 46,000 BTUH - Liquid Propane
BV-4609	Pilot Assembly - Natural Gas
BV-4610	Pilot Assembly - Liquid Propane
BV-4611	Thermocouple
BV-4612	Thermopile
BV-4613	Pilot Orifice - Natural Gas
BV-4614	Pilot Orifice - Liquid Propane
BV-4617	Front Burner
BV-4618	Front Burner Mixer Tube
BV-4619	Middle Burner 46,000 BTUH
BV-4620	Middle Burner 30,000 BTUH
BV-4621	Rear Burner 46,000 BTUH
BV-4622	Rear Burner 30,000 BTUH
BV-4623	Front Orifice Spud Natural Gas 46,000 BTUH - # 55DMS
BV-4624	Middle Orifice Spud Natural Gas 46,000 BTUH - # 45DMS
BV-4625	Rear Orifice Spud Natural Gas 46,000 BTUH - # 40DMS
BV-4626	Front Orifice Spud Liquid Propane 46,000 BTUH - # 69DMS
BV-4627	Middle Orifice Spud Liquid Propane 46,000 BTUH - # 55DMS
BV-4628	Rear Orifice Spud Liquid Propane 46,000 BTUH - # 53DMS
BV-4629	Front Orifice Spud Natural Gas 30,000 BTUH - # 57DMS
BV-4630	Middle Orifice Spud Natural Gas 30,000 BTUH - # 50DMS
BV-4631	Rear Orifice Spud Natural Gas 30,000 BTUH - # 45DMS
BV-4632	Front Orifice Spud Liquid Propane 30,000 BTUH - # 70DMS
BV-4633	Middle Orifice Spud Liquid Propane 30,000 BTUH - # 59DMS
BV-4634	Rear Orifice Spud Liquid Propane 30,000 BTUH - # 55DMS
BV-4640	Front Ceramic Glass with fiberglass tape gasket
BV-4641	Side Ceramic Glass with fiberglass tape gasket , one each
BV-4642	Valve Plate Gasket
BV-4644	Dura Vent Gasket (Set)
BV-4646	Rear Log
BV-4647	Front Log
BV-4648	Top Log
BV-4650	Owner's Manual
BV-4651	Gasket, Door Rope
BV-4652	Tape, Side Glass, one each
BV-4653	Tape, Front Glass
BV-4654	Retainer, Glass Top or Bottom, one each
BV-4655	Retainer, Glass Side, one each
GC-3905	Gas Valve - Natural Gas
GC-3905-01	Regulator - Natural Gas

PARTS LIST (cont'd)

PART NUMBER	DESCRIPTION
GC-3906	Gas Valve - Liquid Propane
GC-3906-01	Regulator - Liquid Propane
GC-3913	On/Pilot/Off Pilot Extension Knob
GC-3914	Hi/Low Extension Knob
GC-3931	Deluxe Remote Control Kit w/ built In Thermostat and Timer
GC-3932	Standard On/Off Remote Kit
GC-3934	Snap Disc Thermostat
GC-3989	Ember Material

All parts for the Bayvue DV product can be purchased by contacting a local authorized Country Flame Dealer. In the event there is no local Country Flame Dealer, contact Country Flame direct by writing, calling, or emailing at the following address:

Country Flame Technologies
900 George Street
Marshfield, Missouri 65706
417-859-0990 (telephone)
417-859-0192 (facsimile)
www.countryflame.com
email@countryflame.com

OPERATING INSTRUCTIONS

FOR YOUR SAFETY READ BEFORE LIGHTING

WARNING: If you do not follow these instructions exactly, a fire or explosion may result causing property damage, personal injury, or loss of life.

- A. The Bayvue DV has a pilot light system that must be lit by hand. Follow these instructions exactly, when lighting the pilot.
- B. BEFORE LIGHTING the pilot light, it is important to smell all around the Bayvue DV for potential gas leaks. Be sure to smell next to the floor because some gas fuel is heavier than air and will settle to the lowest point.

WHAT TO DO IF YOU SMELL GAS

- Do not try to light the Bayvue DV.
- Do not touch any electrical switch; do not use any phone in your building.
- Immediately call your gas supplier from a neighbor's phone. Follow the gas supplier's instructions.
- If you cannot reach your gas supplier, call the fire department.

- C. Use hand pressure to push in or turn the ON/PILOT/OFF control knob. Do not use a tool. If the control knob will not push in or turn by hand, do not attempt repair. Call a qualified service technician. Attempted repair may result in fire or explosion.
- D. Do not use the Bayvue DV if any part has been under water. Immediately call a qualified service technician to inspect the Bayvue DV and replace any part of the control system and any gas control that has been under water.

LIGHTING INSTRUCTIONS

1. **STOP!** Read the safety information above this section.
2. Turn off all electrical power to the Bayvue DV. Open the Bayvue DV bottom panel to expose the gas control panel.
3. Push in on the ON/PILOT/OFF control knob slightly and turn clockwise to "OFF."
4. Wait five minutes to clear out any gas. Then smell for gas including near the floor. If you smell gas, STOP! Follow "B" of the safety information above.
5. Turn ON/PILOT/OFF control knob counterclockwise to "PILOT."
6. Push in the ON/PILOT/OFF control knob and hold in. By repeatedly pressing the piezoelectric igniter, a pilot flame should appear. If flame goes out repeat steps 5 thru 10. If flame stays lit, go to Step 10.
8. Push in and turn the ON/PILOT/OFF control knob counterclockwise to "ON."
9. Close the Bayvue DV bottom access panel.
10. Turn on electrical power to Bayvue DV.
11. The pilot flame should be visible through the door glass in the lower right hand corner between the front and middle logs. See the picture below for parts description and view of normal pilot flame pattern.

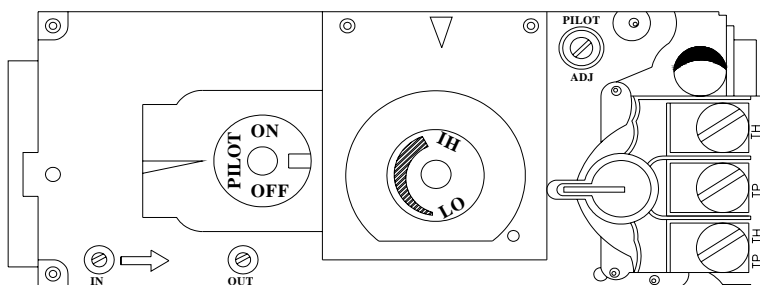

TO TURN OFF GAS TO BAYVUE DV

1. When servicing the Bayvue DV, turn off electrical power.
2. Open the Bayvue DV bottom access panel to see control panel.
3. Push in ON/PILOT/OFF control knob and turn clockwise to "OFF." Do not force.
4. Close the Bayvue DV bottom access panel.

FIRST FIRE

Reduce odor by ventilating the room the first few times the unit is operated. Burn the first two fires no more than 15-20 minutes. Allow the Bayvue DV to completely cool between burns. Burn the third fire 30-40 minutes and allow proper cooling time. Operate the appliance according to the instructions contained in this manual.

SAFETY LABEL

GRAVITY DIRECT VENT WALL FURNACE

Approved for United States:

ANSI - Z21.50 - 2000 Vented Gas Fireplace

MODEL:

	BAYVUE DV 46-N (NATURAL GAS) For use with Natural Gas	BAYVUE DV 46-P (PROPANE) For use with Propane	BAYVUE DV 30-N (NATURAL GAS) For use with Natural Gas	BAYVUE DV 30-P (PROPANE) For use with Propane
Altitude	0' - 4500'	0' - 4500'	0' - 4500'	0' - 4500'
Max. Input	46,000 BTUH	46,000 BTUH	32,000 BTUH	30,000 BTUH
Min. Input	29,000 BTUH	34,500 BTUH	21,000 BTUH	21,500 BTUH
Output Blower Off	35,700 BTUH	36,800 BTUH	22,800 BTUH	22,000 BTUH
Max. Output Blower On	37,260 BTUH	39,100 BTUH	24,000 BTUH	23,100 BTUH
Manifold Pressure	3.5" w.c.	10.0" w.c.	3.5" w.c.	10.0" w.c.
Min. Supply Pressure (For the purpose of input adjustment)	4.5" w.c.	11.0" w.c.	4.5" w.c.	11.0" w.c.
AFUE	68.77%	70.67%	60.19%	62.22%
Orifice (DMS)				
Front Burner	55 DMS	69 DMS	57 DMS	70 DMS
Middle Burner	45 DMS	55 DMS	50 DMS	59 DMS
Rear Burner	40 DMS	53 DMS	45 DMS	55 DMS

NOTE: High Altitude requires air shutter adjustment, see manual.

Electrical Rating: Volts:115, Amps:1.0, Hertz:60

VENTED (OR DIRECT VENT) GAS FIREPLACE HEATER - NOT FOR USE WITH SOLID FUEL.

KEEP BURNER AND CONTROL COMPARTMENT CLEAN.

SEE INSTALLATION AND OPERATING INSTRUCTIONS ACCOMPANYING THIS APPLIANCE. INSTALL & USE ONLY IN ACCORDANCE WITH MANUFACTURER'S INSTALLATION AND OPERATING INSTRUCTIONS.

DUE TO HIGH SURFACE TEMPERATURE, DO NOT TOUCH, KEEP CHILDREN, CLOTHING AND FURNITURE AWAY.

CAUTION: HOT WHILE IN OPERATION. DO NOT TOUCH. KEEP CHILDREN, CLOTHING AND FURNITURE, GASOLINE AND OTHER LIQUIDS HAVING FLAMMABLE VAPORS AWAY.

CAUTION: DO NOT OPERATE THE APPLIANCE WITH GLASS REMOVED, CRACKED OR BROKEN, REPLACEMENT OF THE GLASS SHOULD BE DONE BY A LICENSED OR QUALIFIED SERVICE PERSON.

THIS VENTED GAS FIREPLACE HEATER IS NOT FOR USE WITH AIR FILTERS

WARNING: IMPROPER INSTALLATION, ADJUSTMENT, ALTERATION, SERVICE OR MAINTENANCE CAN CAUSE INJURY OR PROPERTY DAMAGE. REFER TO THE OWNER'S INFORMATION MANUAL PROVIDED WITH THIS APPLIANCE. FOR ASSISTANCE OR ADDITIONAL INFORMATION CONSULT A QUALIFIED INSTALLER, SERVICE AGENCY OR THE GAS SUPPLIER.

LABEL # 35-0500-05

SERIAL NO. [REDACTED]

MANUFACTURED BY:
COUNTRY FLAME TECHNOLOGIES
A DIVISION OF AMERICAN PRODUCTS, L.L.C.
MARSHFIELD, MISSOURI

CERTIFIED BY:



WARNING: DO NOT OPERATE THE APPLIANCE UNTIL ALL VENTING SECTION HAVE BEEN ASSEMBLED AND INSTALLED IN ACCORDANCE WITH THE MANUFACTURE'S INSTRUCTION.

THIS APPLIANCE MUST BE PROPERLY CONNECTED TO A VENTING SYSTEM IN ACCORDANCE WITH THE MANUFACTURE'S INSTALLATION INSTRUCTIONS

MINIMUM CLEARANCE REQUIRED FROM COMBUSTIBLE CONSTRUCTION FOR ALL APPLIANCE SURFACES.

A. LEFT SIDE	6"
RIGHT SIDE	6"
B. BACK WALL	6"
C. TOP OF UNIT	36"
D. VENT SURFACES	1"
ALL SIDES	
E. CORNER CLEARANCE	1"

VENTING INSTRUCTIONS

STANDARD SIDEWALL VENTING	MIN.	MAX.	MIN.	MAX.
VERTICAL VENTING	VERTICAL	VERTICAL	HORIZONTAL	HORIZONTAL
MINIMUM WALL THICKNESS 4"	24"	7'-0"	11"	9'-0"
MAXIMUM WALL THICKNESS 20"	N/A	34'-0"	N/A	N/A

THIS APPLIANCE MUST BE PROPERLY CONNECTED TO A VENTING SYSTEM IN ACCORDANCE WITH THE MANUFACTURER'S INSTALLATION INSTRUCTIONS BY A QUALIFIED INSTALLER.

ATTENTION: THIS APPLIANCE MUST BE INSTALLED IN ACCORDANCE WITH LOCAL CODES, IF ANY, IF NOT, FOLLOW THE CURRENT ANSI - Z223.1.

Free Manuals Download Website

<http://myh66.com>

<http://usermanuals.us>

<http://www.somanuals.com>

<http://www.4manuals.cc>

<http://www.manual-lib.com>

<http://www.404manual.com>

<http://www.luxmanual.com>

<http://aubethermostatmanual.com>

Golf course search by state

<http://golfingnear.com>

Email search by domain

<http://emailbydomain.com>

Auto manuals search

<http://auto.somanuals.com>

TV manuals search

<http://tv.somanuals.com>