

Operator's Manual



3.4 HP, 2-Cycle
53 cc/3.2 cu. in.
235 mph/705 cfm

BACKPACK AIR BLOWER

Model 360.796900



CAUTION:

Before using this product, read this manual and follow all Safety Rules and Operating Instructions.

- Safety
- Assembly
- Operation
- Maintenance
- Parts
- Español

Sears, Roebuck and Co., Hoffman Estates, IL 60179 U.S.A
Visit our Craftsman website www.sears.com/craftsman

Dear Valued Customer,

When you operate your new Craftsman air blower don't expect to hear the high-pitched engine noise commonly associated with motorized power equipment.

This is a blower designed to meet the needs of both professional and occasional users and comply with future noise and emission standards. Many years of research and engineering went into creating this quieter, more efficient unit. By redesigning the engine, fan, and blower housing components, noise emissions were cut by 50%. Engine speed was lowered by 2,500 RPM, which reduces noise, fuel consumption, and emissions, while increasing operating time between refueling with the added benefit of a longer engine life.

Incorporating a very powerful engine and specially designed high volume fan the Craftsman blower is able to achieve maximum air power at only 4,800 RPM. Competitive blowers typically run at 7,000 to 8,000 RPM. This air blower is quiet and powerful, features you and your neighbors will quickly appreciate.

TABLE OF CONTENTS

• Warranty	Pg. 2	• Storage	Pg. 8
• Safety	Pg. 3	• Troubleshooting	Pg. 9
• Contents of Carton	Pg. 4	• California Emission Control	Pg.10
• Accessories	Pg. 4	• Warranty Statement	
• Assembly	Pg. 4	• Parts	Pg.11
• Operation	Pg. 5	• Español	Pg.17
• Maintenance	Pg. 7		

WARRANTY

LIMITED TWO YEAR WARRANTY

For two (2) years from the date of purchase if the backpack air blower is maintained, lubricated and tuned up according to the instructions in the Operator's Manual, Sears will repair or replace, free of charge, any parts found to be defective in material or workmanship. If this product is used commercially, this warranty only applies for 90 days.

This warranty does not cover:

- Expendable items which become worn during normal use, such as spark plugs and air filters.
- Repairs necessary because of operator abuse, negligence, improper storage, accident, or the failure to maintain the equipment according to the instructions contained in the Operator's Manual.

Warranty service is available by returning the air blower to the nearest Sears Service Center in the United States. This warranty gives you specific legal rights, and you may also have other rights which may vary from state to state.

Sears, Roebuck and Co., Dept. 817WA, Hoffman Estates, IL 60179

PRODUCT SPECIFICATIONS

Horse Power	3.4
Fuel-Oil Capacity	1.6 U. S. qt.
Fuel-Oil Mix	40-1
Spark Plug (Gap .020 in)	Bosch WSR6F Champion RCJ-6Y
Air Velocity	235 mph
Air Volume	705 cfm
Maximum RPM	4500 rpm
Dry Weight	20.5 lbs.

Model No. 360.796900

Serial No. _____

Date of Purchase _____

The model and serial number will be found to the left of the fuel cap. You should record both serial number and date of purchase and keep in a safe place for future reference.

SAFETY INSTRUCTIONS

CAUTION: Always disconnect spark plug wire and place where it cannot contact spark plug to prevent accidental starting when setting up, transporting, adjusting or making repairs.

TRAINING

Read the operator's manual carefully. Become familiar with the controls and know how to operate your air blower properly.

- Do not allow children to use your air blower. Never allow adults to use air blower without proper instructions.
- Keep the area of operation clear of all persons, especially small children and pets.
- Use air blower only as described in this manual.
- Do not operate air blower if it has been dropped or damaged in any manner. Always have damage repaired before using your air blower.
- Do not use accessory attachments that are not recommended by the manufacturer. Use of such attachments may be hazardous.

PREPARATION

- Always wear safety glasses or eye shields when starting and while using your air blower.
- Dress properly. Do not operate air blower when barefoot or wearing open sandals. Wear only solid shoes with good traction.
- Wear long-sleeved clothes that are snug fitting. Avoid wearing loose clothing.
- Wear either tightly cuffed or cuffless pants.
- Wear hearing protection even when working for a short period of time. Remember – hearing damage is cumulative.
- Wear protective, non-slip gloves for safer operation.
- Check fuel tank before starting engine. Do not fill fuel tank indoors, when the engine is running or when the engine is hot. Allow the engine to cool for several minutes before filling the fuel tank. Clean off any spilled gasoline before starting the engine.
- Always make adjustments before starting your air blower. Never attempt to do this while the engine is running.
- Use only in daylight or good artificial light.

OPERATION

- Keep your eyes and mind on your air blower and the area being blown. Don't let other interests distract you.
- Always be sure of your footing. Use extra caution in wet or slippery areas. WALK – DON'T RUN.

- Do not put hands or feet near rotating parts. Keep clear of the nozzle opening at all times.
- Always stop the engine whenever you leave or are not using your air blower.
- Before cleaning, inspecting, or repairing your air blower, stop the engine and make absolutely sure all moving parts have stopped. Then disconnect the spark plug wire and keep it away from the spark plug to prevent accidental starting.
- Do not adjust carburetor. Overspeeding, engine damage or personal injury may result.
- Do not operate your air blower if it vibrates abnormally. Excessive vibration is an indication of damage; stop the engine, safely check for the cause of vibration and repair as needed.
- Do not run the engine indoors. Exhaust fumes are dangerous.
- Never operate your air blower without proper guards, tubes, or other safety devices in place.

WARNING: *California Proposition 65*

The engine exhaust from this product contains chemicals known to the State of California to cause cancer, birth defects, or other reproductive harm.

MAINTENANCE AND STORAGE

- Check the engine mounting bolts often to be sure they are tightened properly.
- Check all bolts, nuts, and screws at frequent intervals for proper tightness to be sure air blower is in safe working condition.
- Keep all safety devices in place and working.
- To reduce fire hazard, keep the engine free of debris and excessive grease and oil.
- Allow engine to cool before storing in any enclosure.
- Never store air blower with fuel in the tank inside a building where fumes may reach an open flame or an ignition source such as hot water heater, space heater, clothes dryer, etc.

CUSTOMER RESPONSIBILITIES

- Read and observe the Safety Rules.
- Follow a regular schedule in maintaining, caring and using your air blower.
- Follow the instructions under the Maintenance and Storage sections of this manual

CONTENTS OF CARTON

Read these instructions and the operating manual in its entirety before you attempt to operate your new air blower.

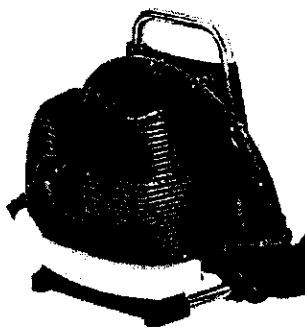

Blower

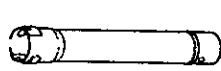

Blower Tube



Curved Nozzle Tube



Extension Tube



Pleated Tube



Clamp



Clamp with Cable Guide



Combi-Wrench

ACCESSORIES

The following items for the operation of your blower are available at your nearest Sears store.

- Safety goggles
- Hearing protection
- Gloves
- 2-Cycle air cooled engine oil
- Air filter
- Fuel stabilizer
- Spark plug
- Gas can

ASSEMBLY

Read these instructions and the operating manual in its entirety before you attempt to assemble or operate your new backpack air blower.

Your new backpack air blower has been assembled at the factory except for the blower tubes. The necessary clamps to complete assembly as well as a combination wrench are included in the parts bag enclosed with the unit.

To ensure safe and proper operation of your backpack air blower, any clamp that you install must be tightened securely.

HOW TO ASSEMBLE

1. The elbow tube is already inserted into the blower housing. Insure that the two screws (Fig. 1, A) are tight, but not so tight that the tube cannot be easily swiveled.

FIGURE 1

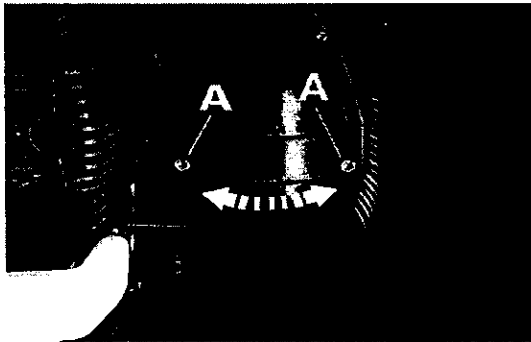

2. Slide the pleated tube (Fig. 2, E) onto the elbow (Fig. 2, B) and secure with the clamp (Fig. 2, C) that has an attached cable guide. Install throttle cable (Fig. 2, D) into the clamp cable guide.

FIGURE 2

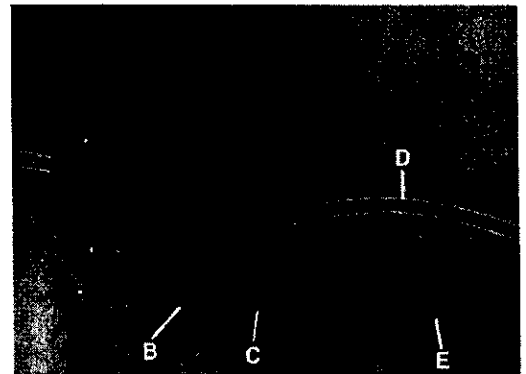

3. Loosen the two screws (Fig. 3, H) on the bottom of the attached handle clamp. Make sure that the clamp goes over the top of the raised "T" on the underside of the blower tube, and that the leg of the "T" is aligned with the slot on the clamp. Push blower tube into the pleated tube and secure with the plastic clamp (Fig. 3, G). The multi-function handle (Fig. 3, F) has a 2-inch adjustment range. Locate the most comfortable handle location and

then tighten the multi-function handle to blower with the two screws (Fig. 3, H).

FIGURE 3

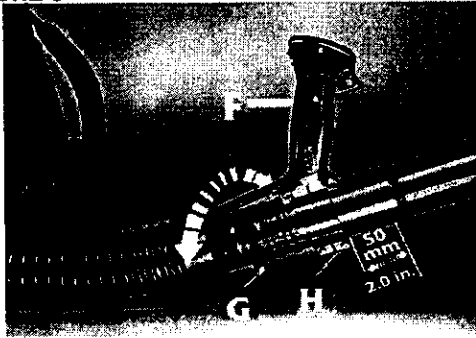

4. Once the handle is secured, the blower tube with handle can be twisted and swiveled. Ensure that the throttle cable does not become pinched or trapped when swiveling handle.
5. Install the extension tube (if desired) onto blower tube by aligning the tab on the extension with the corresponding area on blower tube; then push together and twist to secure.
6. Install the curved nozzle tube in the same manner. Twist to secure.

OPERATION

KNOW YOUR BACKPACK AIR BLOWER

Read this Operator's Manual and Safety Instructions before operating your backpack air blower. Compare the illustration below (Figure 4) with your backpack air blower to familiarize yourself with the location of various controls and adjustments. Save this manual for future reference.

- | | |
|----------------------------------|----------------------------------|
| 1. On-off switch | 12. Anti-vibration springs |
| 2. Throttle lever | 13. Quick release carrying strap |
| 3. Speed lever | 14. Carrying strap |
| 4. Primer | 15. Carrying frame |
| 5. Choke lever | 16. Pleated tube |
| 6. Air filter cover | 17. Blower tube |
| 7. Fuel tank cap | 18. Extension tube |
| 8. Starter rope handle | 19. Curved nozzle tube |
| 9. Spark plug | 20. Blower housing |
| 10. Muffler | 21. Clamp |
| 11. Carburetor adjustment screws | 22. Clamp with cable guide |

FIGURE 4

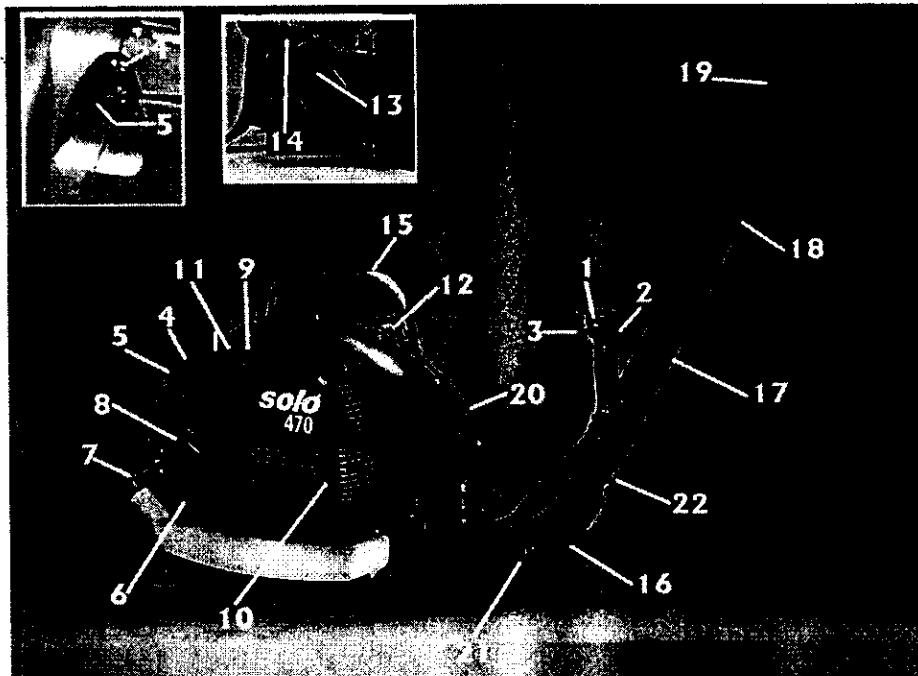

HOW TO USE YOUR BACKPACK AIR BLOWER

GASOLINE AND OIL MIXTURE

Important! Do not use automotive or boat oils in your air blower. These oils do not have proper additives for 2-cycle, air-cooled engines and can cause engine damage.

The 2-cycle engine on this product requires a fuel mixture of regular unleaded gasoline and a high quality 2-cycle air-cooled engine oil for lubrication of the bearings and other moving parts. The correct fuel:oil mixture is 40-1 (see Fuel Mixture Chart). Too little oil or the incorrect oil type will cause poor performance and may cause the engine to overheat and seize.

Gasoline and oil must be premixed in a clean approved fuel container. Always use fresh regular unleaded gasoline. This engine is certified to operate on unleaded gasoline.

FUEL MIXTURE CHART

GASOLINE	OIL
1 Gallon	3.2 Ounces
2.5 Gallons	8.0 Ounces

IMPORTANT! Alcohol blended fuels called gasohol (using ethanol or methanol) can attract moisture, which leads to oil/gas separation and formation of acids during storage. Acidic gas can damage the fuel system of an engine while in storage. To avoid engine problems, the fuel system should be emptied before storage of 30 days or longer. Drain the gas tank, then run the fuel out of the carburetor and fuel lines by starting the engine and letting it run until it stops. Use fresh fuel next season. See storage instructions for additional information. Never use engine or carburetor cleaner products in the fuel tank or permanent damage may occur.

2-CYCLE OIL

Craftsman 2-cycle, air-cooled engine oil is specially blended with fuel stabilizers. If you do not use this Sears oil, you can add a fuel stabilizer, such as Craftsman No. 33500, to your fuel mix.

FUEL STABILIZER

A fuel stabilizer is an acceptable alternative in minimizing the formation of fuel gum deposits during storage. Add stabilizer to gasoline mixture in fuel storage container and mix well. Always follow the fuel mix ratio found on the stabilizer container. Run engine at least 5 minutes after adding stabilizer to allow the stabilizer to reach the carburetor. You do not have to drain the fuel tank for storage if you are using fuel stabilizer.

USING THE MULTI-FUNCTION HANDLE

The multi-function handle has an on-off switch (Fig. 5, A), a throttle lever (Fig. 5, B), and a speed lever (Fig. 5, C). It can be rotated to assure the operator's comfort. Once started, the speed lever can be set at a desired RPM. This frees the operator from holding the throttle lever. If not set on maximum RPM and a greater RPM is required, simply squeeze the throttle lever. To return to the lower RPM, release the throttle lever. If the operator plans on blowing at the maximum RPM for a long period of time, the speed lever is moved to the "max" setting. If the operator is only blowing in short bursts leave the speed lever at the "min" setting and use the throttle lever to control the speed.

FIGURE 5

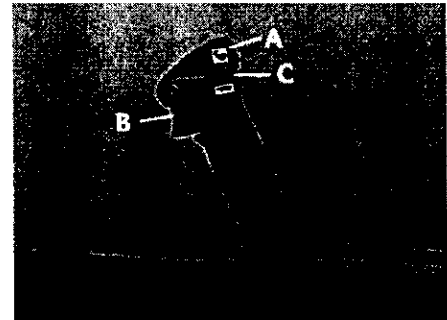

STARTING COLD

1. Move on-off switch to the on position identified with an "I" (Fig. 5).
2. Set speed lever half way between the "min" and "max" positions (Fig. 5).
3. Move choke lever (Fig. 6, A) to the "START" position.
4. Press primer bulb (Fig. 6, B) until it is half full and resistance is felt.
5. Place left hand on top of the blower housing near carrying handle. Pull the starter rope handle with right hand slowly until resistance is felt. Then pull forcefully and repeatedly until engine attempts to start; usually 2-3 pulls, no more than 5 pulls.
6. When engine attempts to start, immediately move choke lever to "RUN" position. Continue to pull starter rope handle until engine starts.

FIGURE 6

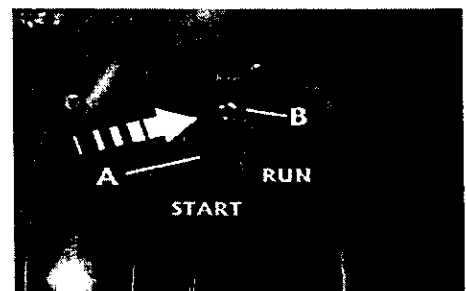

STARTING WARM

Follow cold starting instructions but leave choke lever in "RUN" position.

STOPPING

To stop engine, release the throttle lever and adjust the speed lever to "min" position. Move switch to STOP (O) position. In an emergency, immediately move the switch to the STOP (O) position.

ADJUSTING THE CARRYING STRAPS

Put the blower on your back and your arms through the carrying straps as shown. The back plate of the blower should rest securely against your back. If the straps need to be tightened (Fig. 7), pull the quick adjust ring ends downward as needed. If the straps need to be loosened, lift the couplings located at the bottom of the padded straps.

FIGURE 7

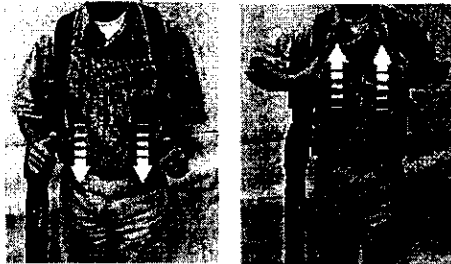

MAINTENANCE

GENERAL RECOMMENDATIONS

The warranty on this air blower does not cover items that have been subjected to operator abuse or negligence. To receive full value from the warranty, operator must maintain air blower as instructed in this manual.

All items in the Maintenance section of this manual should be checked at least once each season.

1. Service more often when operating in dusty or dirty conditions.
2. Once a year you should replace the spark plug and clean or replace the air filter. A new spark plug and a clean air filter assure proper air-fuel mixture and help your engine run better and last longer.

MAINTENANCE SCHEDULE

	Before each use	Every 25 hours	Every 50 hours	Every 100 hours	Every season	Before storage
BLOWER						
Check for loose fasteners	X					
Clean air filter		X				
Inspect muffler			X			
ENGINE						
Replace spark plug				X	X	
Clean fuel filter					X	
Clean engine cooling fins				X		X
Clean spark arrestor screen		X				

BLOWER

CHECK FASTENERS

Check all fasteners, including nuts, bolts, screws and clamps, to insure that they are tight and secure. If not, make all necessary adjustments prior to using air blower.

CLEAN AIR FILTER

Your engine will not run properly and may be damaged by using a dirty air filter. Replace air filter element if deterioration occurs. Service more often if you use your air blower in very dusty or dirty conditions.

To Clean Air Filter

1. Remove air filter cover by turning black knob counterclockwise.
2. Remove foam air filter.
3. Shake out air filter. If heavily soiled, rinse in a mild soap and water solution.
4. Dry air filter completely and oil slightly by placing a small amount of oil on filter and kneading until evenly distributed. Wipe off excess oil.
5. Reassemble the air filter and cover; ensure that the filter is correctly seated in its slot before reinstalling cover.
6. Replace air filter element if deteriorated.

INSPECT MUFFLER

Inspect muffler every 25 hours of use and replace if corroded.

ENGINE

REPLACE SPARK PLUG

Change your spark plug each year to make your engine start easy and run better. Set spark plug gap at .020".

CLEAN FUEL FILTER

The fuel filter is located inside the fuel tank and is attached to the fuel line. To clean, scrub fuel filter surface with a small brush. Replace if deteriorated.

CLEAN ENGINE CYLINDER COOLING FINS

For best performance, keep dirt from accumulating around the engine cooling fins. Clogged cooling fins cause the engine to run hotter and shorten engine life. Cooling fins may be cleaned using a toothbrush or stiff bristle brush.

CLEAN SPARK ARRESTOR SCREEN (if installed)

After every 25 hours of use the spark arrestor screen must be cleaned. Replace screen if deteriorating (part no. 2048391).

To clean:

1. Remove the four screws from the engine cover.
2. Remove the four screws from the end of the muffler.
3. Remove the screen and clean with a wire brush. Replace the screen if deteriorated.
4. Re-install the screen and muffler end. Secure with the four screws.
5. Re-install the engine cover.

CARBURETOR ADJUSTMENT

To comply with emission regulations, the carburetor mixture is pre-set at the factory and can not be adjusted without proper tools. Any adjustment must be performed by a service center.

The idle speed can be adjusted. The idle speed set screw is located on the top of the unit and to the left of the spark plug. It is indicated by the letter "T". To adjust the idle speed, turn clockwise to increase and counterclockwise to decrease idle speed. Idle speed is 2100 ± 100 RPM.

STORAGE

Prepare your backpack air blower for storage at the end of the season or if the unit will not be used for 30 days or more.

BEFORE STORING

1. Use soap and water to wipe down unit.
2. Be sure that all nuts, bolts, screws, and fasteners are securely fastened. Inspect for damaged or worn parts. Replace if necessary.

BLOWER TUBES

The straight blower tubes can be removed to ease storage. Use care not to "kink" the throttle cable.

ENGINE

It is important to prevent gum deposits from forming in essential fuel system parts such as the carburetor, fuel filter, fuel hose, or tank during storage. Also, alcohol blended fuels, such as gasohol, ethanol or methanol, can attract moisture, which leads to separation and formation of acids during storage. Acidic gas can damage the fuel system of an engine while in storage. Do not store gasoline from one season to the next. Two-cycle mix ages quickly and can cause engine damage. Replace your gasoline container if it starts to rust. Rust or dirt in your gasoline will cause engine problems.

To avoid engine problems, the fuel system should be emptied before storage of 30 days or more.

Follow these instructions:

1. Drain the fuel tank.
2. Start engine and let it run until the fuel lines and carburetor are empty. (The engine will stop.)
3. Use fresh gas next season.
4. If you use a fuel stabilizer, the gasoline can be left in the tank. **CAUTION:** Never store air blower inside a building with fuel in the tank! Fumes can concentrate and possibly reach a source of ignition. Allow engine to cool before storage.
5. Remove spark plug.
6. Pour a few drops of oil into the cylinder.
7. Pull the starter handle slowly to distribute the oil.
8. Replace spark plug.

STORAGE TIPS

If possible, store your unit indoors and cover it to give it protection from dust and dirt. Do not use plastic. Plastic cannot breathe, which will allow condensation to form and will cause your unit to rust. **IMPORTANT:** Never cover air blower while engine and muffler are still warm.

TROUBLESHOOTING

PROBLEM	CAUSE	CORRECTION
Engine smokes excessively.	<ol style="list-style-type: none"> 1. Dirty air filter. 2. Fuel mixture incorrect. 3. Carburetor requires maintenance. 	<ol style="list-style-type: none"> 1. Clean or replace air filter. 2. Verify you have 40-1 fuel mixture. 3. Contact Sears Service Center.
Engine hard to start, will not start or starts and only runs a few seconds.	<ol style="list-style-type: none"> 1. Fuel tank empty. 2. Engine flooded. 3. Spark plug not firing. 4. Dirty air filter. 5. Carburetor requires adjustment. 6. Stale fuel mix or water in fuel mix. 7. Spark plug wire disconnected. 8. Switch in STOP (O) position. 	<ol style="list-style-type: none"> 1. Fill tank with correct fuel mix. 2. Remove and clean spark plug; with spark plug removed and engine switched off, crank engine a few times to remove excess fuel from cylinder. Reinstall spark plug. 3. Replace spark plug. 4. Clean or replace air filter. 5. Contact Sears Service Center. 6. Drain tank and refill with fresh, clean fuel mix. 7. Connect wire to plug. 8. Move switch to RUN (I) position.
Engine will not accelerate, lacks power or dies under a load.	<ol style="list-style-type: none"> 1. Dirty air filter. 2. Spark plug fouled. 3. Spark arrestor screen clogged (if applies). 4. Carburetor requires maintenance. 	<ol style="list-style-type: none"> 1. Clean or replace air filter. 2. Clean or replace spark plug and re-gap (.020"). 3. Clean or replace screen. 4. Contact Sears Service Center.

CALIFORNIA EMISSION CONTROL WARRANTY STATEMENT

The California Air Resources Board and Sears are pleased to explain the emission control system warranty on your 1996 and later lawn and garden equipment engine. In California, new lawn and garden equipment engines must be designed, built, and equipped to meet the state's stringent anti-smog standards. Sears must warrant the emission control system on your lawn and garden equipment engine for the period of time listed below provided there has been no abuse, neglect, or improper maintenance of your lawn and garden equipment engine.

Your emission control system includes parts such as the carburetor or fuel injected system, the ignition system, and connectors and other emission-related assemblies.

Where a warrantable condition exists, Sears will repair your lawn and garden equipment engine at no cost to you including diagnosis, parts, and labor.

MANUFACTURER'S WARRANTY COVERAGE:

The 1996 and later lawn and garden equipment engines are warranted for two years. If any emission-related part on your engine is defective, the part will be repaired or replaced by Sears.

OWNER'S WARRANTY RESPONSIBILITIES:

As the lawn and garden equipment engine owner, you are responsible for the performance of the required maintenance listed in your Operator's Manual. Sears recommends that you retain all receipts covering maintenance on your lawn and garden equipment engine. Sears cannot deny warranty solely for the lack of receipts or for your failure to ensure the performance of all scheduled maintenance.

As the lawn and garden equipment engine owner, you should however be aware that Sears may deny you warranty coverage if your lawn and garden equipment engine or a part has failed due to abuse, neglect, improper maintenance or unapproved modifications.

You are responsible for presenting your lawn and garden equipment engine to a Sears repair center as soon as a problem exists. The warranty repairs should be completed in a reasonable amount of time, not to exceed 30 days.

If you have any questions regarding your warranty rights and responsibilities, you should contact Sears at 1-800-473-7247.

A. WARRANTY COMMENCEMENT DATE

The warranty period begins on the date the equipment is purchased by a retail customer.

B. LENGTH OF WARRANTY COVERAGE

Sears warrants to the initial owner and each subsequent purchaser that the engine is free from defects in materials and workmanship for a period of two years from date of original purchase from Sears.

C. WHAT IS COVERED

1. REPAIR OR REPLACEMENT OF PARTS

Repair or replacement of any warranted part will be performed at no charge to the owner at a warranty station. To locate a warranty station, you may call Sears at 1-800-473-7247, (24 hours, 7 days a week).

2. WARRANTY PERIOD

Any warranted part which is not scheduled for replacement as required maintenance, or which is scheduled only for regular inspection to the effect of "repair or replace as necessary" shall be warranted for the warranty period. Any warranted part which is scheduled for replacement as required maintenance shall be warranted for the period of time up to the first scheduled replacement point for that part.

3. DIAGNOSIS

The owner shall not be charged for diagnostic labor, which leads to the determination that a warranted part is defective, if the diagnostic work is performed at Sears.

4. CONSEQUENTIAL DAMAGES

The engine manufacturer is liable for damages to the engine components caused by the failure of a warranted part still under warranty.

D. WHAT IS NOT COVERED

1. Failures caused by abuse, neglect, or improper maintenance.
2. Add-on or modified parts. The use of add-on or modified parts can be grounds for disallowing a warranty claim. The engine manufacturer is not liable to cover failures of warranted parts caused by the use of add-on or modified parts.
3. Any indirect or consequential damages that may result from the failure or malfunction of the Sears product. Some states do not allow the exclusion or limitation of consequential damages so these limitations may not apply to you.
4. Normal service requirements arising during the warranty period such as carburetor or ignition adjustment, cleaning, normal wear, lubrication, spark plugs, filters, starter ropes, etc.
5. Normal service work over and above the repair or replacement of defective parts.
6. Any failure that results from an accident, customer abuse, normal wear, neglect or failure to operate the product in accordance with the instructions provided in the Operators Manual or provided with the product.
7. Pre-delivery set-up time.
8. Operation of an engine with an incorrect fuel:oil ratio, air filter removed or speeds in excess of Sears' recommendations (if applicable).
9. Transportation costs associated with delivering and return of product to a Sears warranty station.

E. HOW TO FILE A CLAIM

Warranty claims may be submitted on several different forms:

Sears Warranty Claim Request
Outdoor Power Equipment Institute
Universal Warranty Claim Report
Engine Service Association Claim

Warranty claims must be received at Sears within 60 days of the date of repair noted on the claim.

F. WHERE TO GET WARRANTY SERVICE

Warranty service or repairs shall be provided at Sears Service Centers. For the address of a Service Center near you call Sears at 1-800-473-7247, (24 hours, 7 days a week).

G. MAINTENANCE, REPLACEMENT AND REPAIR OF EMISSION RELATED PARTS

Sears replacement parts must be used in the performance of any warranty maintenance or repairs on emission-related parts and will be provided without charge during the warranty period.

H. EMISSION CONTROL WARRANTY PARTS LIST

Sears' warranty includes the following parts (unless said part was scheduled for replacement as required maintenance): Air Filter, Fuel Filter, Carburetor and Internal parts, Choke Mechanism, Intake Manifold, Spark Plug, Flywheel, Ignition Module.

I. MAINTENANCE STATEMENTS

Follow normal maintenance service, recommended fuel mixture (where applicable), lubrication, operation and storage of the product as explained in the Operator's Manual. The owner shall not be charged for diagnostic labor, which leads to the determination that a warranted part is defective, if the diagnostic work is performed at Sears.

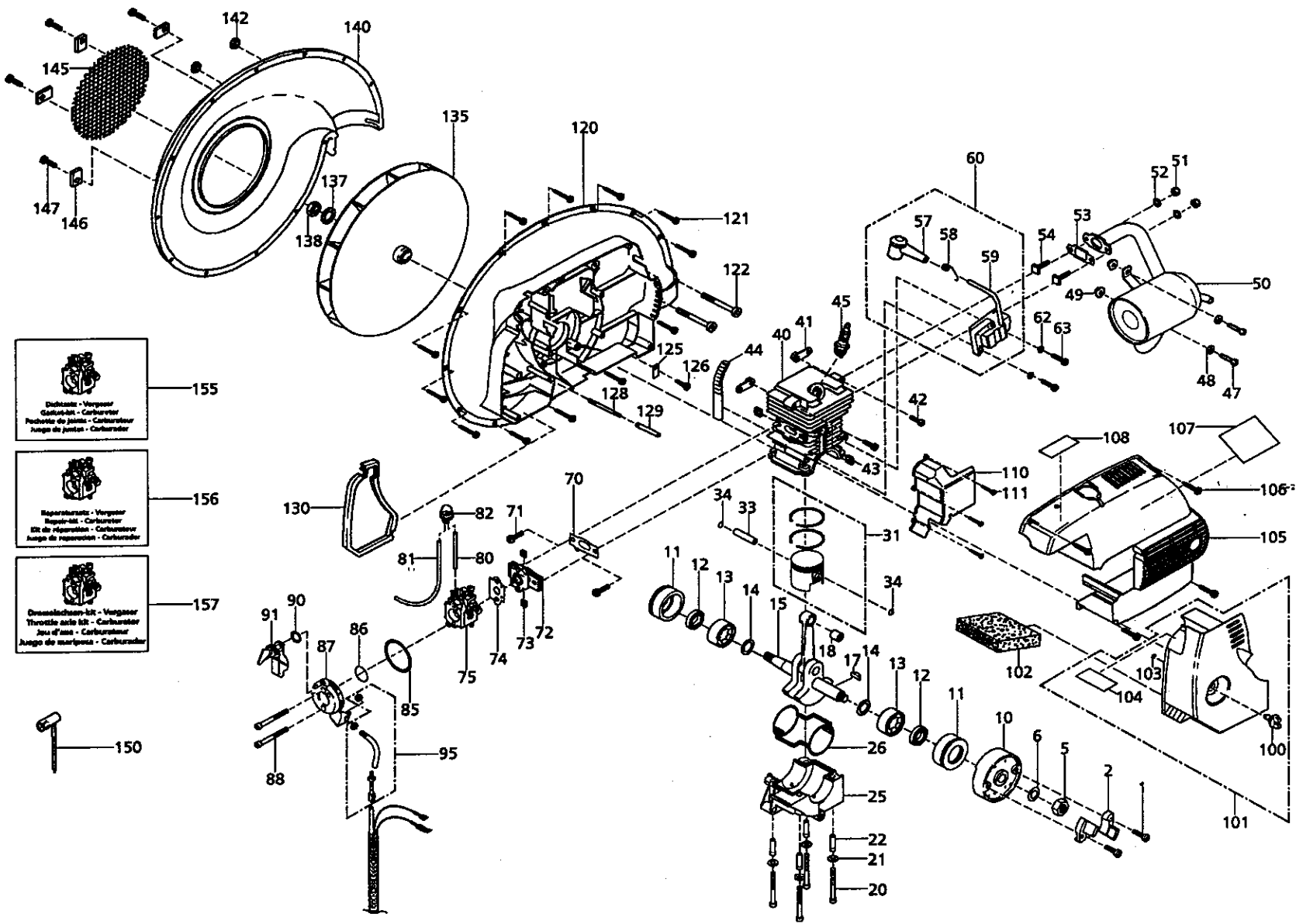

155
 Dichtung - Vergeper
 Gaskets - Carburateur
 Puchete de joints - Carburateur
 Juego de juntas - Carburador

156
 Reparatursatz - Vergeper
 Repair kit - Carburateur
 Kit de réparation - Carburateur
 Juego de repuestos - Carburador

157
 Drosselventil - Vergeper
 Throttle valve - Carburateur
 Jeu d'axe - Carburateur
 Juego de mariposa - Carburador

150

Pos.-No.	Order-No.	Quantity	Description
1	00 18 346	2	screw
2	20 16 428	2	activator
5	00 20 104	1	nut
6	00 34 135	1	circlip
10	23 00 774	1	flywheel
11	20 74 294	2	sleeve
12	00 54 220	2	oil seal
13	00 50 102	2	ball bearing
14	00 31 375	2	washer
15	22 00 249	1	crankshaft
17	00 75 101	1	spring washer
18	00 52 226	1	needle bearing
20	00 18 340	4	screw
21	00 72 140	4	spring washer
22	00 33 358	4	spacer tube
25	21 00 629	1	crankcase, compl.
26	20 63 334	1	gasket
31	22 00 248	1	piston
33	20 31 117P	1	piston pin
34	00 55 207	2	piston pin circlip
40	20 11 802	1	cylinder
41	25 00 732	2	flap
42	00 18 348	2	screw
43	00 21 256	2	nut
44	40 63 160	1	seal
45	23 00 730	1	spark plug
47	00 18 363	2	screw
48	00 72 144	2	tension washer
49	20 74 562	2	insulator
50	25 00 731	1	muffler
51	00 28 100	2	nut
52	00 72 143	2	tension washer
53	20 61 510	1	exhaust gasket
54	00 18 421	2	screw
57	00 84 600	1	spark plug cap
58	00 73 385	1	contact spring
59	23 00 783	1	ignition coil
60	23 00 773	1	ignition coil, compl., incl.
(57)	00 84 600	1	spark plug cap
(58)	00 73 385	1	contact spring
(59)	23 00 783	1	ignition coil
62	00 72 148	2	washer
63	00 18 327	2	screw
70	20 61 512	1	manifold gasket
71	00 18 337	2	screw
72	20 74 916	1	manifold
73	00 21 235	1	nut
74	20 61 515	2	carburetor gasket
75	23 00 805	1	carburetor
80	00 64 407	1	hose
81	00 64 436	1	hose
82	27 00 322	1	primer
85	00 62 321	1	ring
86	00 62 325	1	ring
87	20 74 917	1	suction flange
88	00 10 107	1	screw
90	00 62 263	2	ring
91	20 74 914	1	choke flap
95	28 00 566	1	throttle cable
100	68 00 286	1	screw
101	4100109DGN	1	exhaust cover, incl.
(100)	68 00 286	1	screw
(103)	00 55 279	1	safety ring
(104)	00 69 721	1	decal

Pos.-No.	Order-No.	Quantity	Description
102	40 48 380	1	filter plate
103	00 55 279	1	safety ring
104	00 69 721	1	decal
105	4073679DGN	1	engine cover
106	00 18 363	4	screw
107	00 69 168	1	decal
108	00 69 716	1	decal
110	20 73 503	1	air guide
111	00 18 363	3	screw
120	4073676DGN	1	blower housing 1
121	00 18 363	12	screw
122	00 18 342	2	screw
125	20 42 667	1	clamping plate
126	00 18 362	1	screw
128	00 15 155	1	screw
129	00 33 393	1	spacer
130	40 61 908	1	air filter gasket
135	44 00 241	1	fanwheel
137	00 34 135	1	circlip
138	00 20 104	1	nut
140	4073677DGN	1	blower housing 2
142	00 20 101	2	nut
145	40 36 415	1	protection screen
146	40 42 800	4	support plate
147	00 18 362	4	screw
150	00 80 509	1	combi wrench
155	05 10 949	1	gasket-kit-carburetor
156	05 10 975	1	repair-kit-carburetor
157	05 10 976	1	throttle axle kit-carburetor

MODEL NUMBER 360.796900

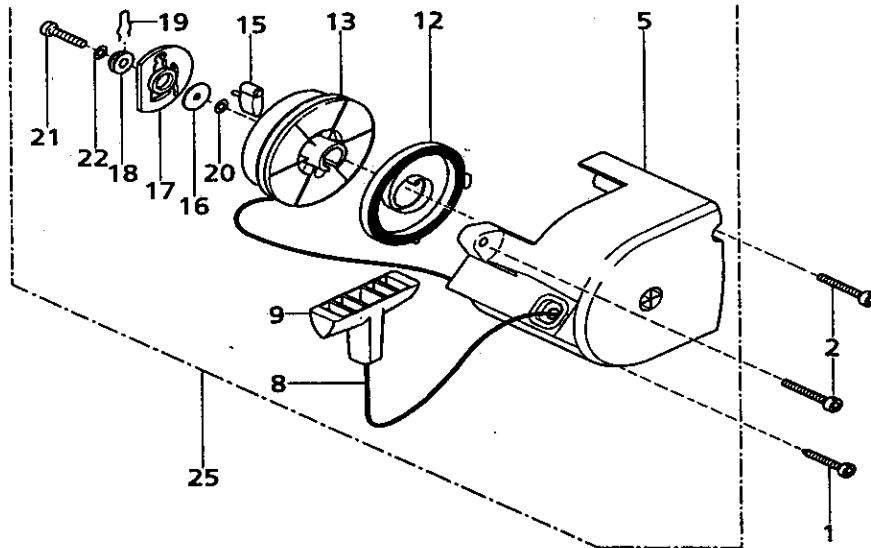

Pos.-No.	Order-No.	Quantity	Description
1	00 18 257	1	screw
2	00 18 338	2	screw
5	21 00 583	1	starter housing
8	00 63 195	1	starter rope
9	20 74 569	1	starter grip
12	26 00 284	1	spring cassette
13	20 74 915	1	rope pulley
15	20 74 343	1	starter pawl
16	00 31 611	1	washer
17	20 74 977	1	template
18	20 31 965	1	spacer
19	00 73 365	1	pin
20	00 34 126	1	spring washer
21	00 10 519	1	screw
22	00 34 152	1	circlip
25	26 00 293	1	starter, compl.

MODEL NUMBER 360.796900

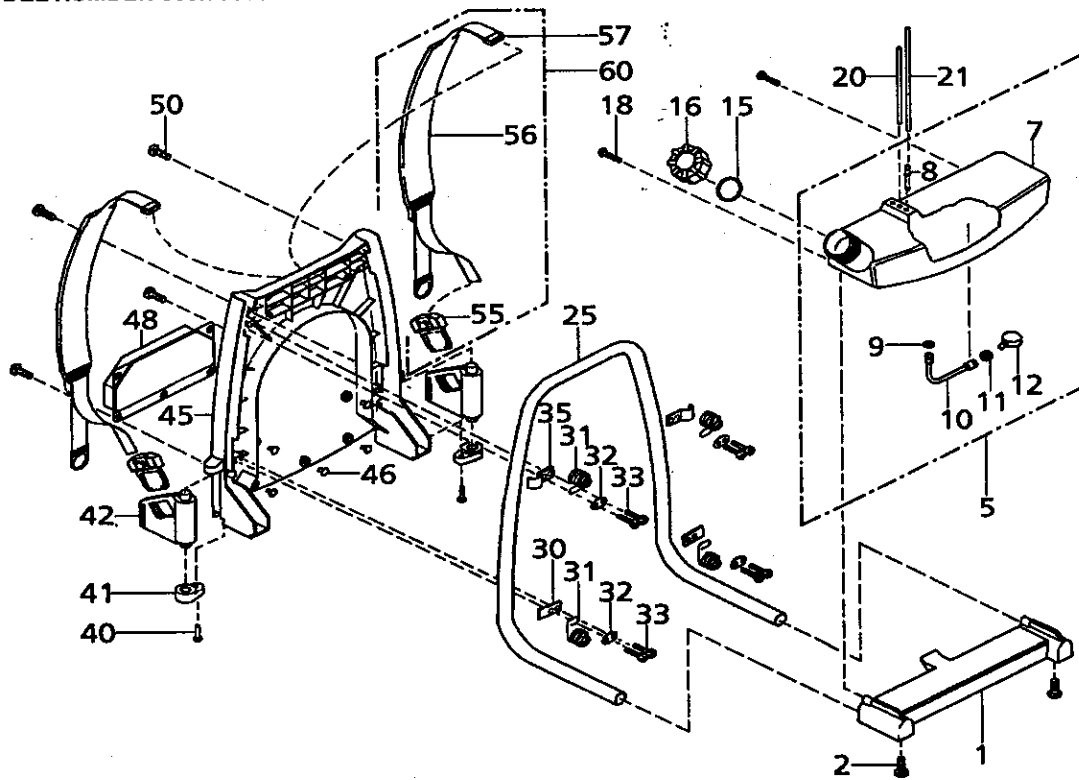

Pos.-No.	Order-No.	Quantity	Description
1	40 73 682	1	bottom plate
2	00 18 363	2	screw
5	27 00 409	1	fuel tank, incl.:
(7)	40 71 272	1	fuel tank
(8)	00 67 114	1	socket
(9)	00 73 351	1	grommet
(10)	60 63 328	1	fuel hose
(11)	00 73 352	1	grommet
(12)	27 00 327	1	fuel pick-up
7	40 71 272	1	fuel tank
8	00 67 114	1	socket
9	00 73 351	1	grommet
10	60 63 328	1	fuel hose
11	00 73 352	1	grommet
12	27 00 327	1	fuel pick-up
15	00 61 280	1	lid gasket
16	27 00 395	1	tank cap, compl.
18	00 18 274	2	screw
20	00 64 435	1	hose
21	00 64 300	1	hose
25	40 35 904	1	carrying frame

Pos.-No.	Order-No.	Quantity	Description
30	40 42 577	2	tension plate
31	00 73 396	4	av spring
32	60 43 107	4	flange plate
33	00 18 363	8	screw
35	40 46 100	2	tension bracket
40	00 18 363	2	screw
41	40 74 126	2	cap
42	40 74 275	2	strap holder
45	40 73 680	1	back plate
46	40 74 962	5	cushion rivet
48	00 98 147	1	back cushion
50	00 18 369	1	screw
55	40 74 921	2	strap clamp
56	43 00 355	2	shoulder strap
57	40 74 412	2	strap holder, black
60	43 00 332	2	shoulder strap, inc.:
(55)	40 74 921	2	strap clamp
(56)	43 00 335	2	shoulder strap
(57)	40 74 412	2	strap holder, black
61	00 18 370	3	screw

MODEL NUMBER 360.796900

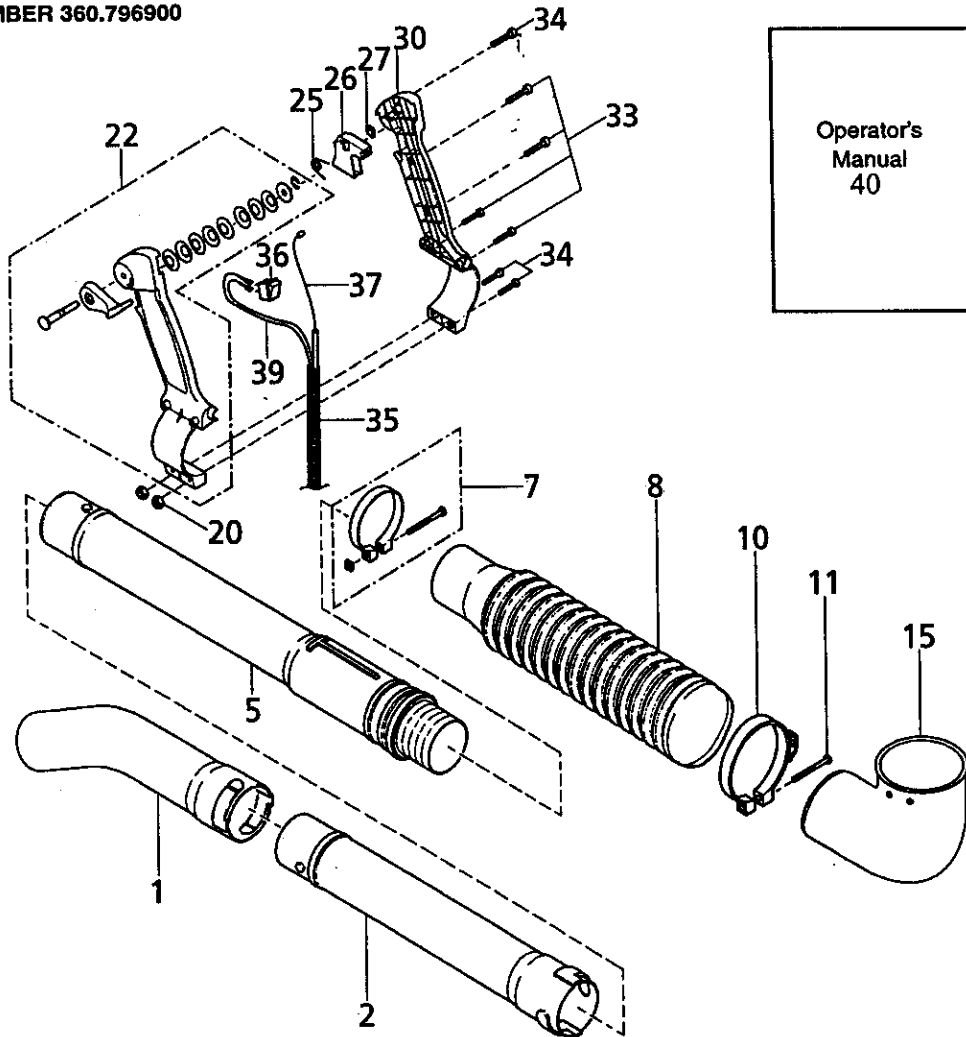

Pos.-No.	Order-No.	Quantity	Description
1	40 71 289	1	curved nozzle tube
2	40 71 288	1	extension tube 2
5	44 00 248	1	blower tube 1
7	00 66 399	1	clamp, compl.
8	40 71 148	1	pleated tube
10	00 66 130	1	clamp with cable guide
11	00 18 257	1	screw
15	40 73 124	1	elbow tube
20	00 20 101	2	nut
22	48 00 222	1	grip half left, compl.
25	00 73 408	1	spring
26	40 73 673	1	throttle lever
27	00 35 159	1	washer
30	40 74 938	1	outer grip half
33	00 18 356	4	screw
34	00 18 357	3	screw
35	00 64 415R	1	hose
36	00 84 477	1	on-off switch
37	28 00 566	1	throttle cable
39	00 84 855	1	on-off cable
40	D9470102	1	Operator's Manual

Free Manuals Download Website

<http://myh66.com>

<http://usermanuals.us>

<http://www.somanuals.com>

<http://www.4manuals.cc>

<http://www.manual-lib.com>

<http://www.404manual.com>

<http://www.luxmanual.com>

<http://aubethermostatmanual.com>

Golf course search by state

<http://golfingnear.com>

Email search by domain

<http://emailbydomain.com>

Auto manuals search

<http://auto.somanuals.com>

TV manuals search

<http://tv.somanuals.com>