

Operator's Manual



10 in. DRILL PRESS

With Laser Trac®

Model No. 137.219000

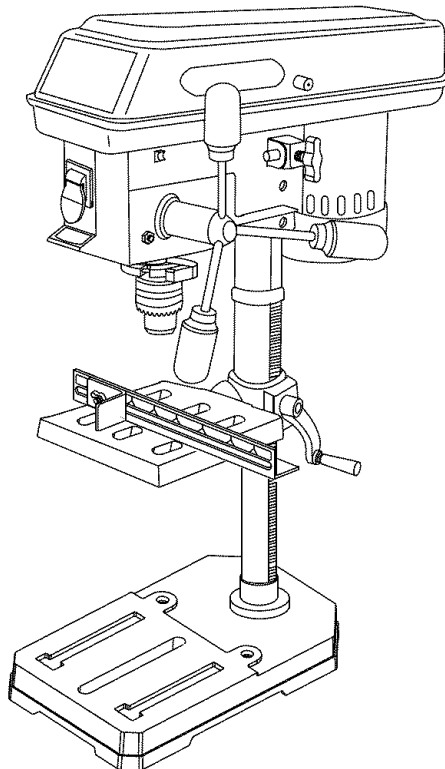

CAUTION:

Before using this Drill Press, read this manual and follow all its Safety Rules and Operating Instructions

- Safety Instructions
- Installation
- Operation
- Maintenance
- Parts List

Customer Help Line
1-800-843-1682

Sears, Roebuck and Co., Hoffman Estates, IL 60179 USA

Visit our Craftsman website: www.sears.com/craftsman

Part No. 13721900001

TABLE OF CONTENTS

SECTION	PAGE	SECTION	PAGE
Warranty	2	Know Your Drill Press.....	8
Product Specifications	2	Glossary of Terms.....	9
Power Tool Safety	3	Assembly and Adjustments.....	10
Drill Press Safety.....	4	Operation.....	16
Electrical Requirements and Safety.....	5	Maintenance	20
Accessories and Attachments.....	6	Troubleshooting Guide.....	21
Tools Needed For Assembly.....	6	Parts List.....	22
Carton Contents	7		

WARRANTY

ONE-YEAR FULL WARRANTY ON CRAFTSMAN TOOL

If this Craftsman tool fails due to a defect in material or workmanship within one year from the date of purchase, **CALL 1-800-4-MY-HOME® TO ARRANGE FOR FREE REPAIR.**

If this tool is used for commercial or rental purposes, this warranty will apply for only ninety days from the date of purchase. This warranty applies only while this tool is in the United States.

This warranty gives you specific legal rights, and you may also have other rights, which vary, from state to state.

Sears, Roebuck & Co., Dept. 817 WA, Hoffman Estates, IL 60179

WARNING

Some dust created by power sanding, sawing, grinding, drilling and other construction activities contains chemicals known to cause cancer, birth defects or other reproductive harm. Some examples of these chemicals are:

- Lead from lead-based paints
- Crystalline silica from bricks, cement and other masonry products
- Arsenic and chromium from chemically treated lumber

Your risk from these exposures varies, depending on how often you do this type of work. To reduce your exposure to these chemicals, work in a well ventilated area and work with approved safety equipment such as dust masks that are specially designed to filter out microscopic particles.

PRODUCT SPECIFICATIONS

Chuck size	1/2 in.
Speed	5 (620~3100 RPM)
Motor	120V, 60Hz
Horsepower	2/3 HP (Max. Developed)
Table tilt	45° Right or Left
Spindle travel	2 in.
Throat	5 in.
Laser guide	YES

WARNING

To avoid electrical hazards, fire hazards or damage to the tool, use proper circuit protection.

This tool is wired at the factory for 110-120 Volt operation. It must be connected to a 110-120 Volt / 15 Ampere time delay fuse or circuit breaker. To avoid shock or fire, replace power cord immediately if it is worn, cut or damaged in any way.

Before using your tool, it is critical that you read and understand these safety rules. Failure to follow these rules could result in serious injury to you or damage to the tool.

POWER TOOL SAFETY

GENERAL SAFETY INSTRUCTIONS

BEFORE USING THIS DRILL PRESS

Safety is a combination of common sense, stay alert and knowing how to use your drill press.

WARNING

To avoid mistakes that could cause serious injury, do not plug the drill press in until you have read and understood the following.

- 1. READ** and become familiar with the entire instruction manual. **LEARN** the tool's application, limitations and possible hazards.
- 2. KEEP GUARDS IN PLACE** and in working order.
- 3. DON'T USE IN DANGEROUS ENVIRONMENT.** Don't use power tools in damp and wet locations, or expose them to rain. Keep work area well lighted.
- 4. DO NOT** use power tools in the presence of flammable liquids or gases.
- 5. KEEP WORK AREA CLEAN.** Cluttered areas and benches invited accidents.
- 6. KEEP CHILDREN AWAY.** All visitors should be kept safe distance from work area.
- 7. DON'T FORCE THE TOOL.** It will do the job better and safer at the rate for which it was designed.
- 8. USE THE RIGHT TOOL.** Do not force a tool or an attachment to do a job for which it was not designed.
- 9. WEAR PROPER APPAREL.** Do not wear loose clothing, gloves, neckties, rings, bracelets, or other jewelry which may get caught in moving parts. Nonslip footwear is recommended. Wear protective hair covering to contain long hair.
- 10. WEAR A FACE MASK OR DUST MASK.** Sawing operation produces dust.
- 11. DISCONNECT TOOLS** before servicing; when changing accessories such as blades, bits, cutters, and the like.
- 12. REDUCE THE RISK OF UNINTENTIONAL STARTING.** Make sure the switch is in the off position before plugging in.
- 13. USE RECOMMENDED ACCESSORIES.** Consult the owner's manual for recommend accessories. The use of improper accessories may cause risk of injury to persons.
- 14. REMOVE ADJUSTING KEYS AND WRENCHES.** Form habit of checking to see that keys and adjusting wrenches are removed from the tool before turning it ON.
- 15. NEVER LEAVE A TOOL RUNNING UNATTEND.** TURN THE POWER "OFF". Don't leave the tool until it comes to a complete stop.
- 16. NEVER STAND ON THE TOOL.** Serious injury could occur if the tool is tipped or if the cutting tool is unintentionally contacted.
- 17. DON'T OVERREACH.** Keep proper footing and balance at all times.
- 18. MAINTAIN TOOLS WITH CARE.** Keep tools sharp and clean for best and safest performance. Follow instructions for lubricating and changing accessories.
- 19. CHECK FOR DAMAGED PARTS.** Before further use of the tool, a guard or other part that is damaged should be carefully checked to determine that it will operate properly and perform its intended function – check for alignment of moving parts, binding of moving parts, breakage of parts, mounting, and any other conditions that may affect its operation. A guard or other part that is damaged should be properly repaired or replaced.
- 20. MAKE WORKSHOP CHILD PROOF** with padlocks, master switches, or by removing starter keys.
- 21. DO NOT** operate the tool if you are under the influence of any drugs, alcohol or medication that could affect your ability to use the tool properly.
- 22. Dust generated from certain material can be hazardous to your health.** Always operate the drill press in a well-ventilated area and provide for proper dust removal. Use a dust collection system whenever possible.
- 23. ALWAYS WEAR EYE PROTECTION.** Any drill press can throw foreign objects into the eyes and could cause permanent eye damage. **ALWAYS** wear Safety Goggles (not glasses) that comply with ANSI Safety standard Z87.1 Everyday eyeglasses have only impact –resistance lenses. They **ARE NOT** safety glasses. Safety Goggles are available at Sears. **NOTE:** Glasses or goggles not in compliance with ANSI Z87.1 could seriously hurt you when they break.



DRILL PRESS SAFETY

WARNING

For your own safety, do not try to use your drill press or plug it in until it is completely assembled and installed according to the instructions, and until you have read and understood this instruction manual:

1. **YOUR DRILL PRESS MUST BE BOLTED** securely to a workbench. In addition, if there is any tendency for your drill press to move during certain operations, bolt the workbench to the floor.
2. **THIS DRILL PRESS** is intended for use in dry conditions, indoor use only.
3. **WEAR EYE PROTECTION.** USE A face or dust mask along with safety goggles if drilling operation is dusty. USE ear protectors, especially during extended periods of operation.
4. **DO NOT** wear gloves, neckties, or loose clothing.
5. **DO NOT** try to drill material too small to be securely held.
6. **ALWAYS** keep hands out of the path of a drill bit. Avoid awkward hand positions where a sudden slip could cause your hand to move into the drill bit.
7. **DO NOT** install or use any drill bit that exceeds 175 mm (7 in.) in length or extends 150 mm (6 in.) below the chuck jaws. They can suddenly bend outward or break.
8. **DO NOT USE** wire wheels, router bits, shaper cutters, circle (fly) cutters, or rotary planers on this drill press.
9. **WHEN** cutting a large piece of material, make sure it is fully supported at the table height.
10. **DO NOT** perform any operation freehand. ALWAYS hold the workpiece firmly against the table so it will not rock or twist. Use clamps or a vise for unstable workpieces.
11. **MAKE SURE** there are no nails or foreign objects in the part of the workpiece to be drilled.
12. **CLAMP THE WORKPIECE OR BRACE IT** against the left side of the column to prevent rotation. If it is too short or the table is tilted, clamp it solidly to the table and use the fence provided.
13. **IF THE WORKPIECE** overhangs the table such that it will fall or tip if not held, clamp it to the table or provide auxiliary support.
14. **SECURE THE WORK.** Use clamps or a vise to hold the work when practical. It's safer than using your hand and it frees both hands to operate tool.
15. **WHEN** using a drill press vise, always fasten to the table.
16. **MAKE SURE** all clamps and locks are firmly tightened before drilling.
17. **SECURELY LOCK THE HEAD** and table support to the column, and the table to the table support before operating the drill press.
18. **NEVER** turn your drill press on before clearing the table of all objects (tools, scraps of wood, etc.)
19. **BEFORE STARTING** the operation, jog the motor switch to make sure the drill bit does not wobble or vibrate.
20. **LET THE SPINDLE REACH FULL SPEED** before starting to drill. If your drill press makes an unfamiliar noise or if it vibrates excessively, stop immediately, turn the drill press off and unplug. If do not restart the unit until the problem is corrected.
21. **DO NOT** perform layout assembly or set up work on the table while the drill press is in operation.
22. **USE THE RECOMMENDED SPEED** for any drill press accessory and for different workpiece material. **READ THE INSTRUCTIONS** that come with the accessory.
23. **WHEN DRILLING** large diameter holes, clamp the workpiece firmly to the table. Otherwise, the bit may grab and spin the workpiece at high speeds. **DO NOT USE** fly cutters or multiple-part hole cutters, as they can come apart or become unbalanced in use.
24. **MAKE SURE** the spindle has come to a complete stop before touching the workpiece.
25. **TO AVOID INJURY** from accidental starting, always turn the switch "OFF" and unplug the drill press before installing or removing any accessory or attachment or making any adjustment.
26. **KEEP GUARDS IN PLACE** and in working order.
27. **USE ONLY THE SELF-EJECTING TYPE CHUCK KEY** as provided with the drill press.

ELECTRICAL REQUIREMENTS AND SAFETY

GROUNDING INSTRUCTIONS

IN THE EVENT OF A MALFUNCTION OR

BREAKDOWN, grounding provides a path of least resistance for electric current and reduces the risk of shock. This tool is equipped with an electric cord that has an equipment grounding conductor and grounding plug. The plug **MUST** be plugged into a matching receptacle that is properly installed and grounded in accordance with ALL local codes and ordinances.

DO NOT MODIFY THE PLUG PROVIDED. If it will not fit the receptacle, have the proper receptacle installed by a qualified electrician.

IMPROPER CONNECTION of the equipment grounding conductor can result in risk of electric shock. The conductor with the green insulation (with or without yellow stripes) is the equipment grounding conductor. If repair or replacement of the electric cord or plug is necessary, **DO NOT** connect the equipment grounding conductor to a live terminal.

CHECK with a qualified electrician or service personnel if you do not completely understand the grounding instructions, or if you are not sure the tool is properly grounded.

USE ONLY 3-WIRE EXTENSION CORDS THAT HAVE 3-PRONG GROUNDING PLUGS AND 3-POLE RECEPTACLE THAT ACCEPT THE TOOL'S PLUG. REPAIR OR REPLACE DAMAGED OR WORN CORD IMMEDIATELY.

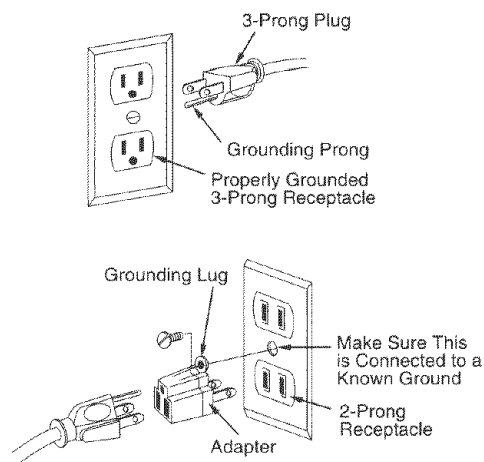

GUIDELINES FOR EXTENSION CORDS

▲ WARNING

This tool must be grounded while in use to protect the operator from electrical.

MINIMUM GAUGE FOR EXTENSION CORDS (AWG)

(When using 120 volts only)

Ampere Rating		Total length of cord in feet			
more than	not more than	25'	50'	100'	150'
0	6	18'	16'	16'	14'
6	10	18'	16'	14'	12'
10	12	16'	16'	14'	12'
12	16	14'	12'	not recommended	

Make sure your extension cord is in good condition. When using an extension cord, be sure to use one heavy enough to carry the current your product will draw. An undersized cord will cause a drop in line voltage resulting in loss of power and overheating. The table below shows the correct size to use according to cord length and nameplate ampere rating. If in doubt, use the next heavier gauge. The smaller the gauge number, the heavier the cord.

Be sure your extension cord is properly wired and in good condition. Always replace a damaged extension cord or have it repaired by a qualified person before using it. Protect your extension cords from sharp objects, excessive heat and damp or wet areas.

Use a separate electrical circuit for your tools. This circuit must not be less than #12 wire and should be protected with a 15 Amp time lag fuse. Before connecting the motor to the power line, make sure the switch is in the OFF position and the electric current is rated the same as the current stamped on the motor nameplate. Running at a lower voltage will damage the motor.

This tool is intended for use on a circuit that has a receptacle like the one illustrated in **FIGURE A**.

FIGURE A shows a 3-prong electrical plug and receptacle that has a grounding conductor. If a properly grounded receptacle is not available, an adapter (**FIGURE B**) can be used to temporarily connect this plug to a 2-contact ungrounded receptacle. The adapter (**FIGURE B**) has a rigid lug extending from it that **MUST** be connected to a permanent earth ground, such as a properly grounded receptacle box. **THE TEMPORARY ADAPTER SHOULD BE USED ONLY UNTIL A PROPER GROUNDING OUTLET CAN BE INSTALLED BY A QUALIFIED ELECTRICIAN.**

CAUTION: In all cases, make certain the receptacle in question is properly grounded. If you are not sure have a certified electrician check the receptacle.

▲ WARNING

This drill press is for indoor use only. Do not expose to rain or use in damp locations.

ACCESSORIES AND ATTACHMENTS

RECOMMENDED ACCESSORIES

▲ WARNING

Use only accessories recommend for this drill press. Follow instructions that accompany accessories. Use of improper accessories may cause hazards.

Visit your Sears Hardware Department or see the Sears Power and hand Tool Catalog for the follow accessories:

- Drill bits
- Hold-Down Clamps
- Drill press Vises

▲ WARNING

Use only accessories designed for this drill press to avoid injury from thrown broken parts or workpieces.

Sears may recommend other accessories not listed in this manual. See your nearest Sears store or Power and Hand Tool Catalog for other accessories.

Do not use any accessory unless you have completely read the instruction or operator's manual for that accessory.

TOOLS NEEDED FOR ASSEMBLY

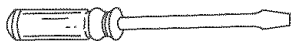

Slotted screwdriver

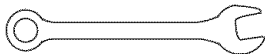

12 mm wrench

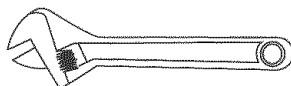

Adjustable wrenches

CARTON CONTENTS

UNPACKING AND CHECKING CONTENTS

▲ WARNING

If any part is missing or damaged, do not plug the drill press in until the missing or damaged part is replaced, and assembly is complete.

Carefully unpack the drill press and all its parts, and compare against the list below.

To protect the drill press from moisture, a protective coating has been applied to the machined surfaces. Remove this coating with a soft cloth moistened with kerosene or WD-40.

▲ WARNING

To avoid fire or toxic reaction, never use gasoline, naphtha, acetone, lacquer thinner or similar highly volatile solvents to clean the drill press.

<u>ITEM</u>	<u>DESCRIPTION</u>	<u>QUANTITY</u>
A.	Head assembly	1
B.	Base	1
C.	Table assembly	1
D.	Column assembly	1
E.	Rack ring assembly	1
F.	Rack	1
G.	Feed handles	3
H.	Worm gear	1
I.	Crank handle	1
J.	Lock handle	1
K.	Hex bolts	4
L.	Fence assembly	1
M.	Triangle knobs	2
N.	Wing nuts	2
O.	Washers	4
P.	3mm & 4 mm Hex keys	2
Q.	Chuck key	1
R.	Chuck	1
S.	Batteries	2

UNPACKING AND CHECKING CONTENTS

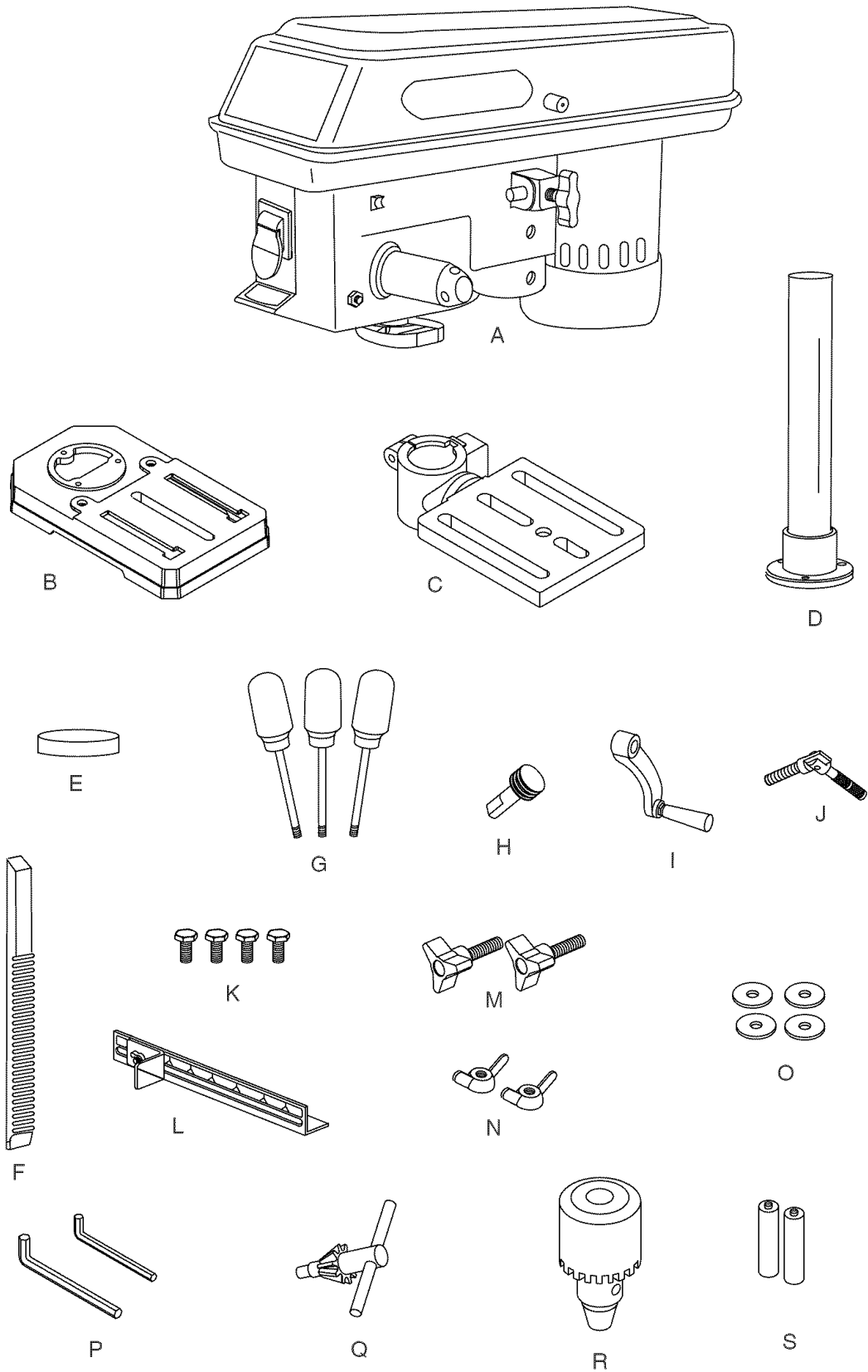

KNOW YOUR DRILL PRESS

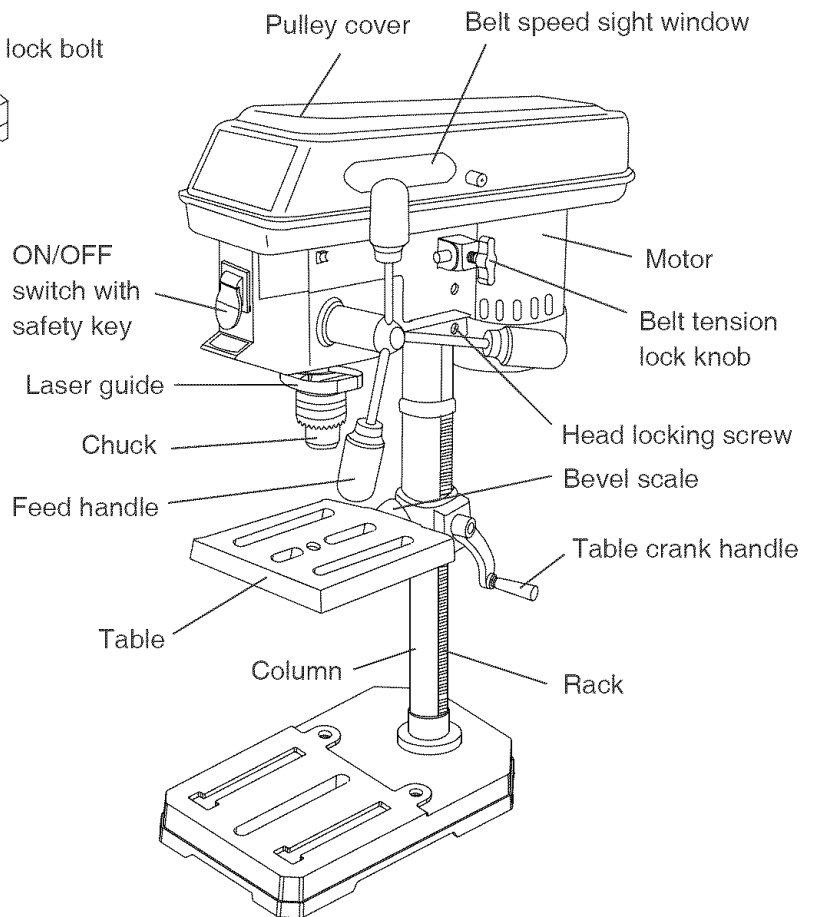
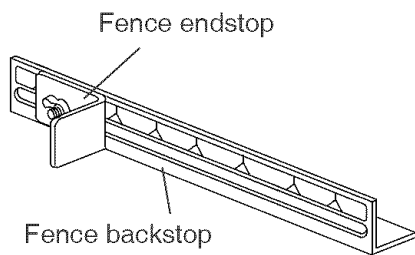
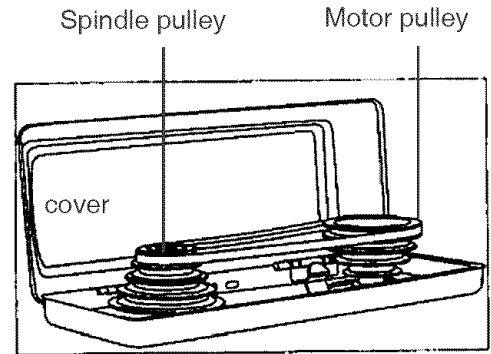
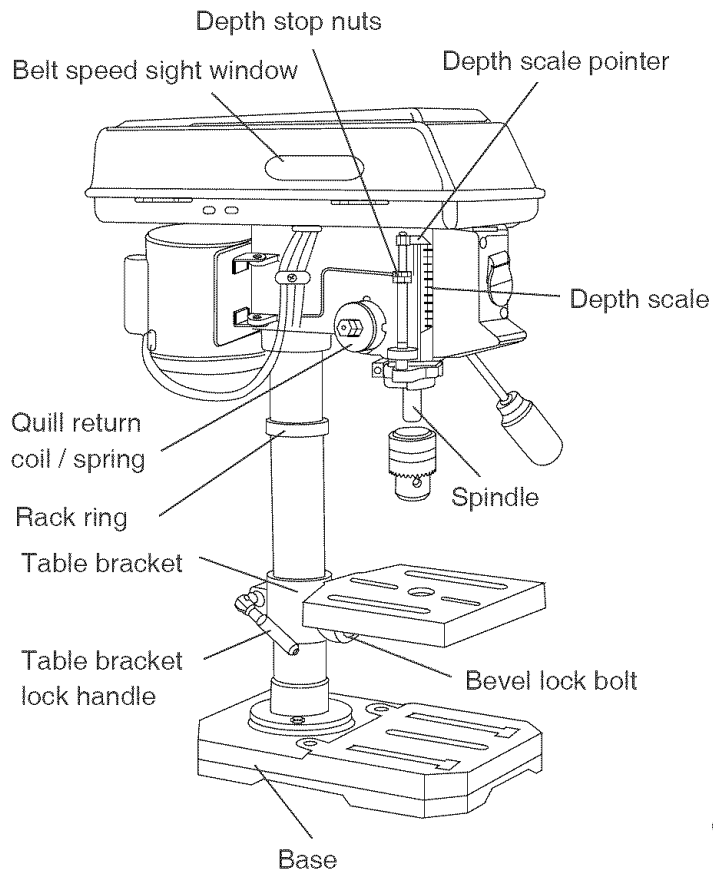

GLOSSARY OF TERMS

BASE – Supports drill press. For additional stability, holes are provided in base to bolt drill press to workbench.

BACKUP MATERIAL – A piece of scrap wood placed between the workpiece and table. The backup board prevents wood in the workpiece from splintering when the drill passes through the backside of the workpiece. It also prevents drilling into the table top.

BELT TENSION – Appropriate belt tension is achieved with approximately 1/2 in. deflection.

BELT TENSION LOCK KNOB – Locks the motor bracket support maintaining correct belt distance and tension.

BEVEL SCALE – Shows degree of table angle for bevel operations.

CHUCK – Holds a drill bit or other recommended accessory to perform desired operations.

CHUCK KEY – A self-ejecting chuck key is provided and designed to pop out of the chuck when you let go of it. This action is designed to help prevent throwing of the chuck key from the chuck when the power is turned ON. Do not use any other key as a substitute.

COLUMN – Connects the head, table, and base on a one piece tube for easy alignment and movement.

DEPTH SCALE – Indicates depth of hole being drilled.

DEPTH SCALE STOP NUTS – Can be adjusted to stop the quill for certain depth drilling operations.

DRILL BIT – The cutting tool used in the drill press to make holes in a workpiece.

DRILLING SPEED – Changed by placing the belt in any of the steps (grooves) in the pulleys. See the Spindle Speed Chart inside belt guard.

FEED HANDLE – Moves the chuck up or down. One or two of the handles may be removed if necessary whenever the workpiece is of such unusual shape that it interferes with the handles.

FENCE – Attaches to the table to align the workpiece or for fast repetitive drilling. Remove fence when it interferes with other drill press accessories.

HEAD LOCKING SCREWS – Locks the head to the column. ALWAYS lock head in place while operating the drill press.

ON/OFF SWITCH – Incorporates a safety switch key which can be removed to prevent access from unauthorized users. Insert the key into the switch to turn the drill press on.

PULLEY COVER ASSEMBLY – Covers the pulleys and belt during operation of the drill press.

RACK – Combines with gear mechanism to provide easy elevation of the table by the table crank handle.

RACK RING – Holds the rack to the column. Rack remains movable in the collar to permit table support movements.

REVOLUTIONS PER MINUTE (R.P.M) – The number of turns completed by a spinning object in one minute.

SPINDLE SPEED – The R.P.M. of the spindle.

SPRING CAP – Adjusts the quill return spring tension.

TABLE – Provides a working surface to support the workpiece.

TABLE BEVEL LOCK BOLT – Locks the table in any position from 0° - 45°.

TABLE CRANK HANDLE – Elevates and lowers table. Support lock handle must be released before operating crank.

TABLE SUPPORT LOCK HANDLE – Tightening locks the table support to the column. Always have it locked in place while operating the drill press.

TABLE BRACKET – Rides on the column to support the table.

WORKPIECE – Material being drilled.

ASSEMBLY AND ADJUSTMENTS

ASSEMBLY INSTRUCTIONS

▲ WARNING

For your own safety, never connect plug to power source outlet until all assembly steps are complete and you have read and understood the safety and operating instructions.

▲ WARNING

The drill press is a heavy power tool and should be lifted with the help of two PEOPLE OR MORE to safely assemble it.

ASSEMBLING COLUMN TO BASE (FIG. A)

1. Position the base (2) on a flat worksurface.
2. Place the column (1) on the base, aligning the mounting holes to the base.
3. Locate the three hex bolts (3) from the loose parts bag.
4. Place a bolt in each hole through the column support and thread into the base. Tighten with a 12mm wrench.

Fig. A

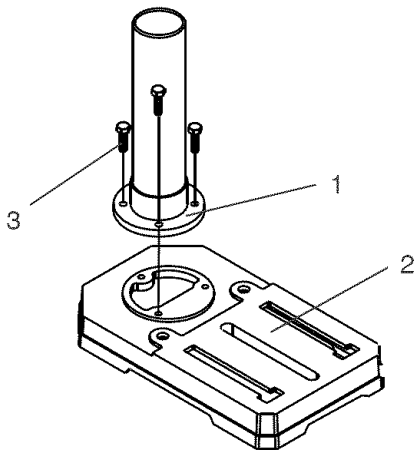

INSTALLING TABLE TO COLUMN ASSEMBLY (FIG. B THROUGH F)

1. Insert the worm gear (1) into the table crank handle hole (2) from inside the table support (3). Make sure the worm gear (1) meshes with the inside raising/lowering gear.
2. Install the table bracket lock handle (4) into the hole at the rear of the table bracket assembly. **NOTE:** Install the handle from left to right, so it enters the non-threaded side of the table bracket first as shown in Fig. C.

NOTE: Table removed from bracket in illustration for clarity.

Fig. B

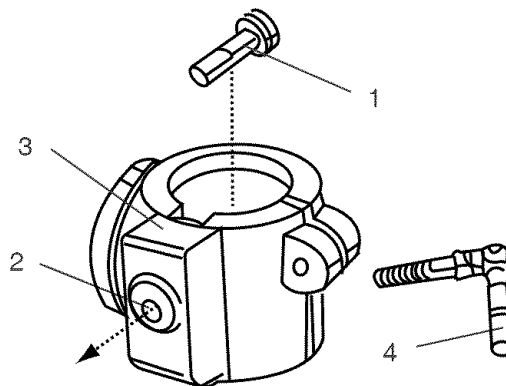

3. Place the rack (5) inside the table bracket (3), making sure the worm gear (1) on the inside of the table bracket is engaged with the teeth of the rack and the arrow stamped on the rack is pointing up.

Fig. C

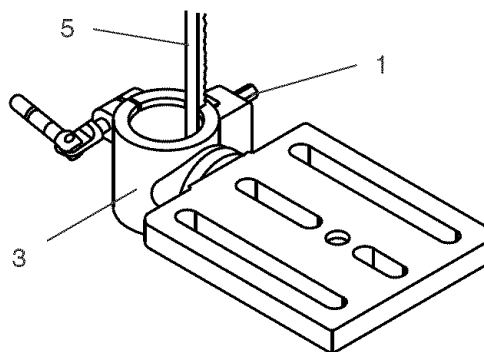

4. Slide the table assembly with the rack onto the column.
5. Engage the bottom of the rack (5) with the lip of the column support (6). Tighten the table bracket lock handle (4) to lock the table assembly to the column.

Fig. D

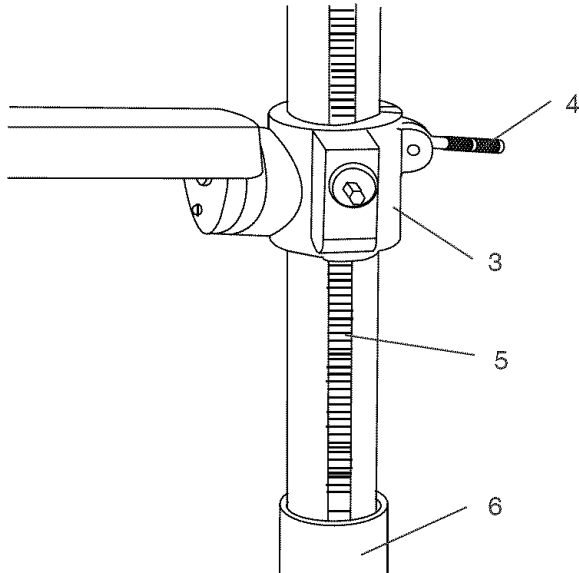

6. Install the rack ring (7) on the column so the top lip of the rack sits into the rack ring.

IMPORTANT: The bottom of the collar MUST NOT be pushed all the way down onto the top of the rack. MAKE SURE the top of the rack is under the bottom of the collar and that there is enough clearance to allow the rack to freely rotate around the column. Tighten the set screw (8).

NOTE: To avoid column or collar damage, DO NOT OVERTIGHTEN the set screw.

Fig. E

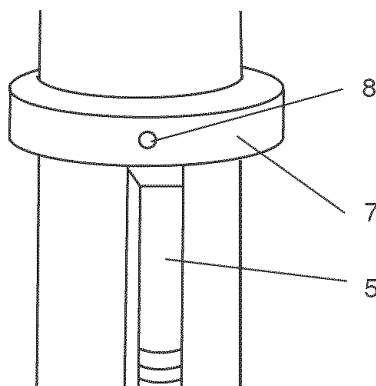

7. Install the table crank handle (9) onto the worm gear shaft (11) on the side of the table support (12).
8. Line up the flat side of the shaft with the set screw (10) in the crank handle and tighten the screw with the 3mm hex wrench provided.

Fig. F

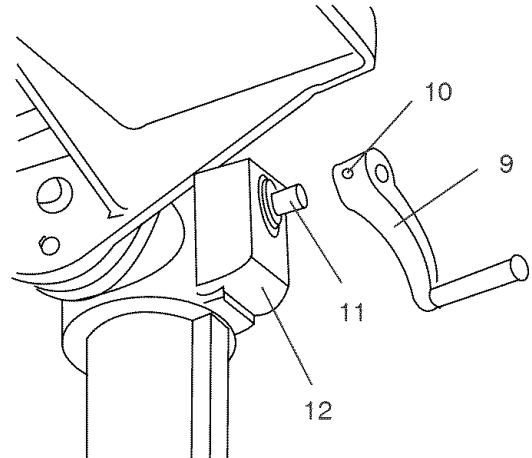

INSTALLING THE HEAD (FIG. G)

WARNING

The Drill Press head is heavy and should be lifted with the help of two PEOPLE OR MORE to safely assemble the drill press head on the column.

1. Carefully lift the head (1) and slide it into the column (2). Make sure the head slides down over the column as far as possible. Align the head with the base.
2. Using the 4mm hex wrench provided, tighten the two head locking setscrews (3) on the right side of the head.

Fig. G

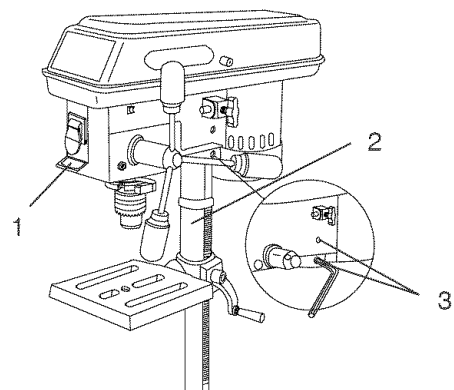

INSTALLING FEED HANDLES (FIG. H)

1. Thread each feed handle (1) into the threaded holes (2) on the hub assembly (3) and Tighten.

Fig. H

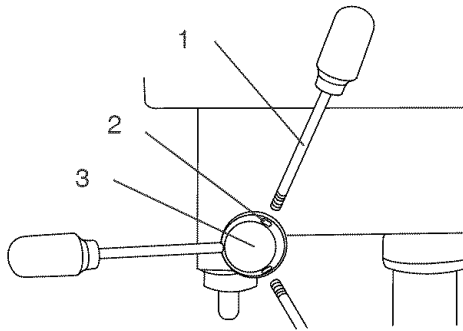

INSTALLING THE CHUCK (FIG. I, J AND K)

1. Clean out the tapered hole in the chuck (1) with a clean cloth and a non-alcohol based cleaner. Wipe clean all oil residue and any dirt or grime thoroughly.
2. Clean tapered surfaces on the spindle (2) in the same manner as above.

NOTE: Make sure there are no foreign particles sticking to the surfaces. The slightest piece of dirt or oil residue on any of these surfaces will prevent the drill chuck and bit to wobble. If tapered hole is extremely dirty, use a non-alcohol based cleaner on a clean rag to clean.

Fig. I

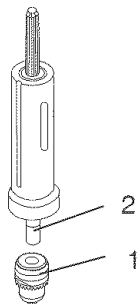

3. Open the jaws of the chuck (1) by rotating the chuck sleeve clockwise. To prevent damage, make sure the jaws are completely receded into the chuck.

Fig. J

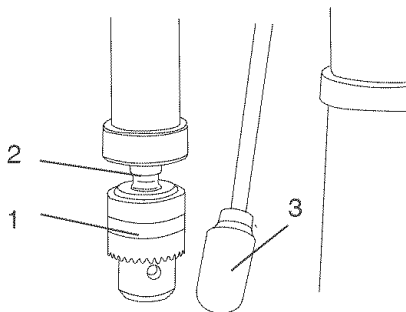

4. Unlock the table support lock (4- Fig. D) and swing the table away from the bottom of the chuck.
5. Using a rubber mallet or a hammer and a block of wood, tap the chuck onto the spindle firmly (Fig. K).

Fig. K

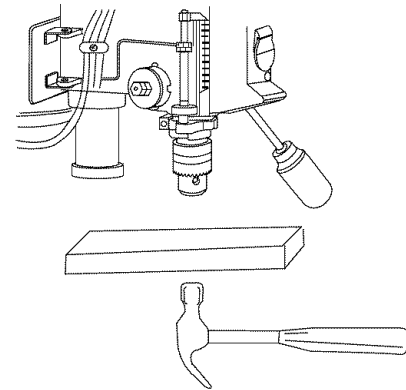

MOUNTING DRILL PRESS TO WORK SURFACE (FIG. L)

1. If mounting the drill press to a workbench, a solid wood bench is preferred over a plywood board, to reduce noise and vibration.
2. Holes should be pre-drilled through the supporting surface.
3. The hardware to mount this drill press is NOT supplied with the tool. The hardware as shown in the illustration should be used:

Fig. L

1. Drill press base
2. Bolt
3. Flat washer
4. Rubber washer
5. Worksurface
6. Flatwasher
7. Lockwasher
8. Hex nut
9. Jam nut

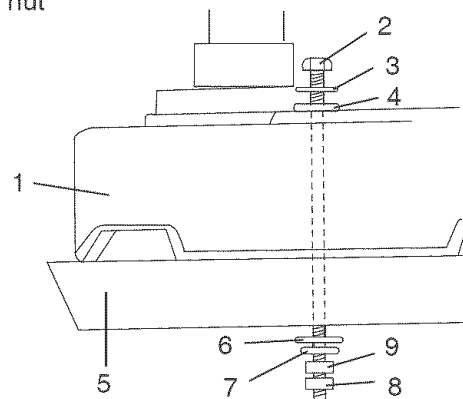

FENCE ASSEMBLY (FIG. M)

1. Align the mounting holes of the fence over the table slots.
2. Place a washer (2) on the threaded end of the knob (3). Insert the knob through the mounting hole of the fence and the table slot.
3. Place a washer and wing nut (4) on the knob from under the table.
4. Repeat for the other knob and tighten.

Fig. M

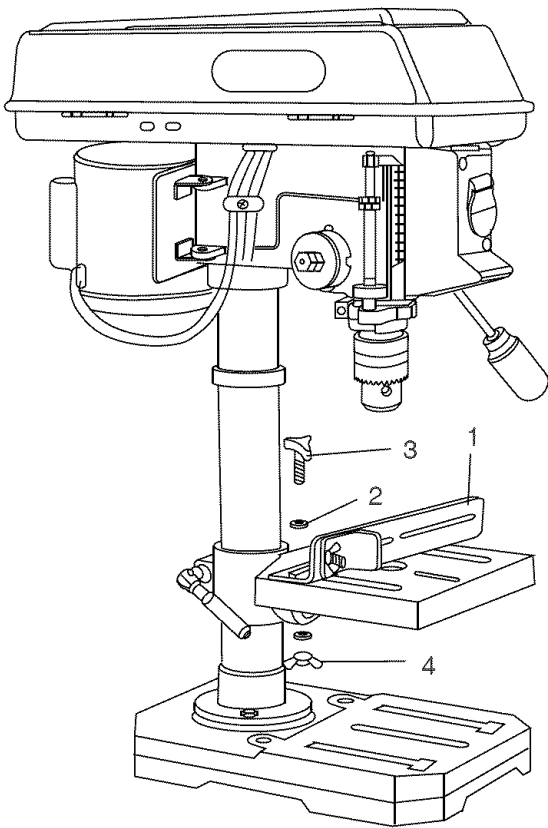

ADJUSTMENTS INSTRUCTIONS

NOTE: All the adjustments for the operation of the drill press have been completed at the factory. Due to normal wear and use, some occasional readjustments may be necessary.

▲ WARNING

To avoid injury from an accidental start, ALWAYS make sure the switch is in the "OFF" position, the switch key is removed, and the plug is not connected to the power source outlet before making belt adjustments.

BEVEL DRILLING (FIG. N)

NOTE: A bevel scale has been included to measure approximate bevel angles. If precision is necessary, a square or other measuring tool should be used to position the table. To use the bevel scale (6):

1. TIGHTEN the nut (4) on the locking pin using a 10mm or adjustable wrench clockwise to RELEASE it from the table support.
2. Loosen the large hex head table bevel locking bolt (5) using a 17mm or adjustable wrench.
3. Tilt the table, aligning the desired angle measurement to the zero line opposite the scale (6).
4. Tighten the table bevel locking bolt (5).
5. To return the table to its original position, loosen the table bevel locking bolt (5). Return the table (6) to the 0° position.
6. Return nut (4) on locking pin to the OUTSIDE END OF THREADS. Gently tap locking pin until it is seated in the mating hole of the table bracket. Hand tighten nut (4).

NOTE: The table has been removed from the illustration for clarity.

Fig. N

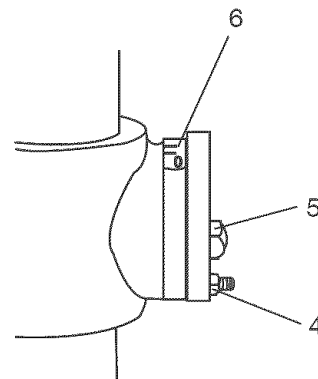

▲ WARNING

To prevent personal injury, always disconnect the plug from the power source when making any adjustments.

SPINDLE / QUILL (FIG. O)

Rotate the feed handles counterclockwise to lower spindle to its lowest position. Hold the chuck and move it front to back. If there is excessive play, proceed with the following adjustments:

1. Loosen the lock nut (1) located on the right side of the drill press.
2. Turn the screw (2) clockwise to eliminate the play, but without obstructing the upward movement of the spindle. (A little play in the spindle is normal.)
3. Tighten the lock nut (1).

Fig. O

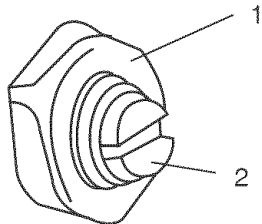

QUILL RETURN SPRING (FIG. P)

The quill return spring may need adjustment if the quill return speed is too rapid or too slow.

1. Lower the table for additional clearance.
2. Place a screwdriver in the lower front notch (1) of the spring cap (2). Hold it in place while loosening and removing only the outer jam nut (3).
3. With the screwdriver still engaged in the notch, loosen the inner nut (4) just until the notch (5) disengages from the boss (6) on the drill press head.

NOTE: DO NOT REMOVE THIS INNER NUT, because the spring will forcibly unwind.

4. Carefully turn the spring cap (2) counterclockwise with the screwdriver, engaging the next notch.
5. Lower the quill to the lowest position by rotating the feed handle in a counterclockwise direction while holding the spring cap (2) in position.
6. If the quill moves up and down as you desire, tighten the inner nut (4) snug against the spring cap and secure the outer nut (3) against the inner nut with the adjustable wrench.

NOTE: DO NOT OVERTIGHTEN and restrict quill movement.

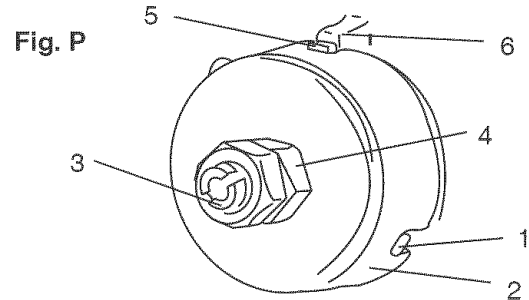

▲ WARNING

To avoid injury from an accidental start, ALWAYS make sure the switch is in the "OFF" position, the switch key is removed, and the plug is not connected to the power source outlet before making belt adjustments.

BELT TENSION (FIG. Q)

1. To unlock the belt tension, turn the belt tension lock knob (1) on the right side of the drill press head counterclockwise.
2. Pull the motor (2) toward the front of the drill press to loosen the belt tension.
3. Position the belt on the correct pulley steps for the desired speed.
4. Push the motor away from the drill press head until the belt is properly tensioned.

NOTE: Belt tension is correct if the belt deflects approximately 1/2 inch when pressed at its center.

5. Tighten the belt tension lock knob (1) to secure the motor in position.

Fig. Q

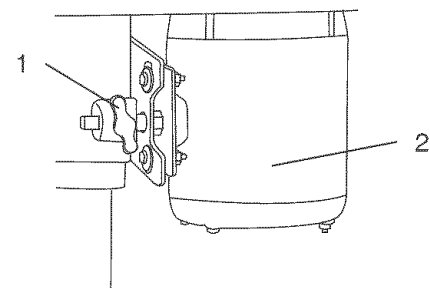

THE LASER TRAC®

Your tool is equipped with our latest innovation, the Laser Trac®, a battery powered device using Class II laser beams. The laser beams will enable you to preview the drill bit path on the workpiece to be drilled before you begin your operation.

WARNING

AVOID DIRECT EYE CONTACT

A Laser light is radiated when the laser guide is turned on. Avoid direct eye contact. Always un-plug the drill press from the power source before making any adjustments.

- A laser pointer is not a toy and should not come into hands of children. Misuse of this appliance can lead to irreparable eye injuries.
- Any adjustment to increase the laser power is forbidden.
- When using the laser pointer, do not point the laser beam towards people and /or reflecting surfaces. Even a laser beam of lower intensity may cause eye damage. Therefore, do not look directly into the laser beam.
- If the laser pointer is stored for more than three months without use, please remove the batteries to avoid damage from possibly leaking batteries.
- The laser pointer includes no servicing components. Never open the housing for repair or adjustments.
- On units equipped with the laser attachment, repairs shall only be carried out by the laser manufacturer or an authorized agent.
- Laser Warning label: Max output <1mW DIODE LASER:630-670nm, Complies with 21CFR 1040.10 and 1040. 11.

ADJUSTING THE LASER LINES (FIG. R)

A. How to check the Laser-beam Alignment?

1. Adjust the table height so it is 5 in. below the bottom of the chuck.
2. Scribe a round circle (approx. 1/8 in.) on a piece of scrap wood.
3. Insert a drill bit approx 1/8 in. diameter into the chuck and tighten.
4. Lower the quill and align the scribed circle with the drill bit and fasten the wood to the table.
5. Turn on the laser and verify the laser lines (x) are centered onto the scribed circle.

B. ALIGNING THE LASER-BEAM (FIG. R)

To adjust the laser lines:

1. Turn on the laser by pressing the rocker switch.
2. Lower the drill press quill and loosen one turn each the four screws (4).
3. To adjust the laser beam left/right, turn the adjustment screw (1) no more than 1/8 turn in either direction. To adjust the laser beam front to back, turn the adjusting screw (2) no more than 1/8 turn in either direction.

4. Once adjustments are completed, retighten the four screws (4).

Fig. R

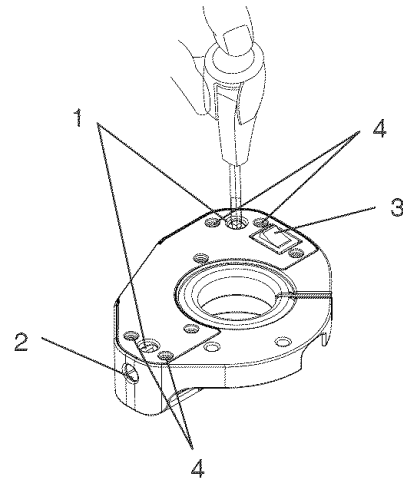

OPERATION

BASIC DRILL PRESS OPERATIONS

NOTE: This machine incorporates view windows on the pulley cover used to observe the location of the belt.

▲ WARNING

To avoid possible injury, keep guard closed and in place while tool is in operation.

SPEEDS AND BELT PLACEMENT (FIG. S)

This drill press has 5 speeds, as listed below:

620 RPM 1100 RPM 1720 RPM
2340 RPM 3100 RPM

See inside of the pulley guard for specific placement of the belts on the pulleys to change speeds.

Fig. S

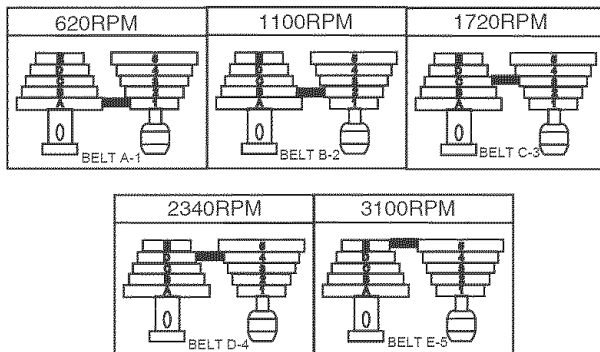

ON/OFF SWITCH (FIG. T)

The ON / OFF switch has a removable, safety switch key. With the key removed from the switch, unauthorized and hazardous use by children and others are minimized as the switch can not be turned on without the key .

1. To turn the drill press "ON", insert key (2) into the slot of the switch (1). Move the switch upward to the "ON" position.
2. To turn the drill press "OFF", move the switch downward.
3. To lock the switch in the OFF position, grasp the sides of the safety switch key, and pull it out.
4. With the switch key removed, the switch will not turn the power tool on.
5. If the switch key is removed while the drill press is running, it can be turned "OFF" but cannot be restarted without inserting the switch key.

▲ WARNING

ALWAYS lock the switch "OFF" when the drill press is not in use by removing the safety switch key keep it in a safe place. In the event of a power failure, blown fuse, or tripped circuit breaker, turn the switch "OFF" and remove the key, preventing an accidental startup when power comes on.

Fig. T

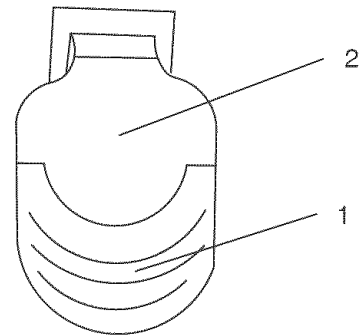

INSTALLING DRILL BIT IN CHUCK (FIG. U)

1. With the switch "OFF" and the switch key removed, open the chuck jaws (1) using the chuck key (2). Turn the chuck key counterclockwise to open the chuck jaws (1).
2. Insert the drill bit (3) into the chuck far enough to obtain maximum gripping by the jaws, but not far enough to touch the spiral grooves (flutes) of the drill bit when the jaws are tightened.
3. Make sure that the drill is centered in the chuck.
4. Turn the chuck key clockwise to tighten the jaws.

▲ WARNING

To avoid injury or accident by the chuck key ejecting forcibly from the chuck when the power is turned "ON", use only the self-ejecting chuck key supplied with this drill press. ALWAYS recheck and remove the chuck key before turning the power "ON".

Fig. U

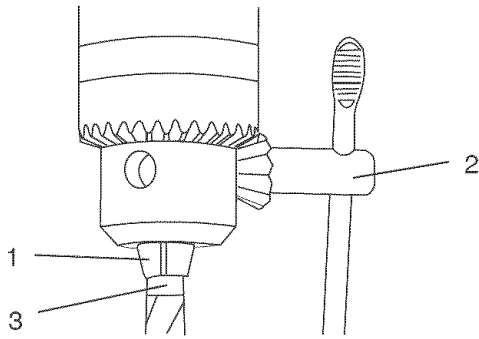

USING THE FENCE (FIG. V)

The fence provides a way of accurately and quickly setting up the workpiece for precision or for repetitive drilling operations.

1. Using a centerpunch or sharp nail, make an indentation in the workpiece where you want to drill.
2. Align the laser lines (x) with the indentation on the workpiece.
3. Loosen the knobs (1) and slide the fence back stop (2) firmly against the long side of the workpiece. Tighten the knobs when in position.
4. Loosen the wing nut (3) and slide the end stop (4) along the fence until it is firmly against the left side of the workpiece. Tighten the wing nut.
5. Check the accuracy by drilling into a scrap workpiece first. Adjust if needed.
6. Hold with your hand or clamp the top surface of the workpiece firmly to prevent it from lifting off the table when the bit is raised.

Fig. V

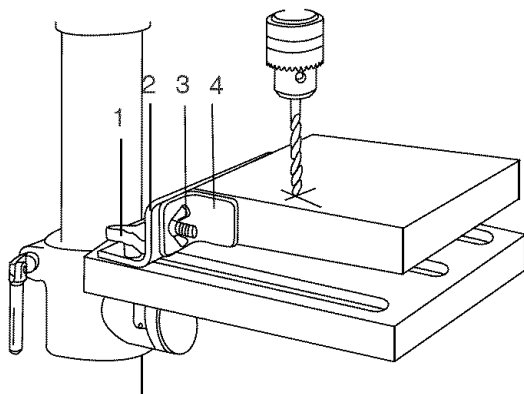

DRILLING TO A SPECIFIC DEPTH

Drilling a blind hole (not all the way through workpiece) to a given depth can be done two ways:

Workpiece method (Fig. W and X)

1. Mark the depth (1) of the hole on the side of the workpiece (Fig. W).
2. With the switch "OFF", bring the drill bit (2) down until the tip is even with the mark (Fig. W)
3. Hold the feed handle at this position.
4. Spin the lower nut (3) down to contact the depth stop lug (6) on the head (Fig. X).
5. Spin the upper nut (5) down and tighten against the lower nut (3) (Fig. X).
6. The drill bit will now stop after traveling the distance marked on the workpiece.

Fig. W

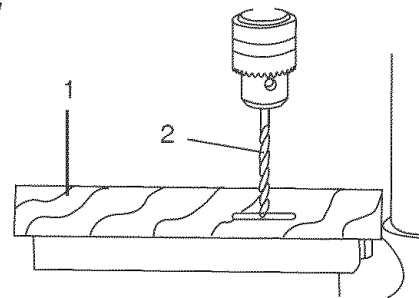

Depth scale method (Fig. X)

Note: With the chuck in the upper position, the tip of the drill bit must be just slightly above the top of the workpiece.

1. With the switch "OFF", turn the feed handle until the pointer (7) points to the desired depth on the depth scale (4) and hold the feed handle in that position.
2. Spin the lower nut (3) down to contact the depth stop lug (6).
3. Spin the upper nut (5) against against the lower stop nut and tighten.
4. The drill bit will stop after traveling the distance selected on the depth scale.

Drill a hole

Using a center punch or a sharp nail, make an indentation in the workpiece where you want to drill. Turn on the laser assembly and align the laser lines (x) with the indentation. Turn the power switch on and pull down on the feed handles with only enough effort to allow the drill to cut.

FEEDING TOO RAPIDLY might cause the belt or drill to slip, tear the workpiece loose, or break the drill bit. When drilling metal, it will be necessary to lubricate the tip of the drill bit with metal drilling oil to prevent it from overheating.

Fig. X

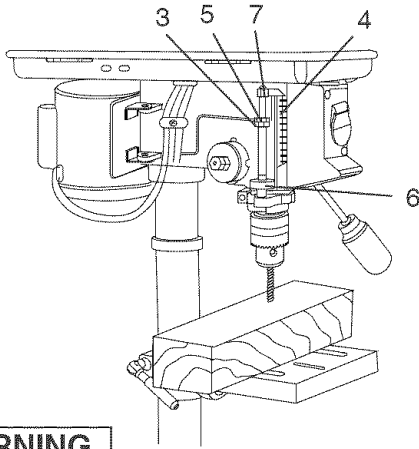

▲ WARNING

To avoid injury from an accidental start, ALWAYS make sure the power switch is in the "OFF" position, the switch key is removed, and the plug is not connected to the power source outlet before removing or installing the chuck.

BASIC OPERATING INSTRUCTIONS

To get the best results and minimize the likelihood of personal injury, follow these instructions for operating your drill press.

▲ WARNING

For your own safety, always read the SAFETY INSTRUCTIONS listed within this operator's manual.

FOR YOUR PROTECTION

▲ WARNING

To avoid being pulled into the power tool, do not wear loose clothing, gloves, neckties, or jewelry. Always tie back long hair.

1. If any part of your drill press is missing, malfunctioning, damaged or broken, stop operation immediately until that part is properly repaired or replaced.
2. Never place your fingers in a position where they could contact the drill bit or other cutting tool. The workpiece may unexpectedly shift, or your hand could slip.
3. To prevent the workpiece from being torn from your hands, thrown, spun by the tool, or shattered, always properly support your workpiece as follows:
 - a. Always position **BACKUP MATERIAL** (used beneath workpiece) so that it contacts the left side of the column, or use the fence provided and a clamp to brace the workpieces.

- b. Whenever possible, position the workpiece to contact the left side of the column. If it is too short or the table is tilted, use the fence provided or clamp solidly to the table, using the table slots.
 - c. When using a drill press vise, always fasten it to the table.
 - d. Never do any work freehand (hand-holding the workpiece rather than supporting it on the table), except when polishing.
 - e. Securely lock the head and support to the column, the table arm to the support, and the table to the table arm, before operating the drill press.
 - f. Never move the head or the table while the tool is running.
 - g. Before starting an operation, jog the motor switch to make sure the drill or other cutting tool does not wobble or cause vibration.
 - h. If a workpiece overhangs the table so it will fall or tip if not held, clamp it to the table or provide auxiliary support.
 - i. Use fixtures for unusual operations to adequately hold, guide, and position workpiece.
 - j. Use the **SPINDLE SPEED** recommended for the specific operation and workpiece material. Check the panel on the inside pulley cover or the chart below for drilling speed information. For accessories, refer to the instructions provided with each accessory.
4. Never climb on the drill press table, it could break or pull the entire drill press down on you.
 5. Turn the power switch "OFF", and put away the switch key when leaving the drill press.
 6. To avoid injury from thrown work or tool contact, do not perform layout, assembly, or setup work on the table while the cutting tool is rotating.

DRILLING SPEED TABLE (RPM)			
DrILL Bit Diam. (Inches)	Material		
	Wood	Alum., Zinc., Brass	Iron, Steel
1/16	3100	3100	3100
1/8			2340
3/16			1720
1/4		2340	1100
5/16			
3/8		1720	
1/2	2340	1100	620

POSITIONING THE TABLE AND WORKPIECE (FIG. AA AND BB)

1. Lock the table (1) to the column (2) at a position so the tip of the drill bit (3) is just above the top of the workpiece (4).
2. ALWAYS place a BACK-UP MATERIAL (scrap wood) on the table beneath the workpiece. This will prevent splintering or heavy burring on the underside of the workpiece. To keep the back-up material from spinning, it MUST be positioned against the LEFT side of the column.
3. For a small piece that cannot be clamped to the table, use a drill press vise (optional accessory).

▲ WARNING

To prevent the workpiece or backup material from being thrown while drilling, you MUST position the workpiece against the LEFT side of the column. If the workpiece or the backup material is not long enough to reach the column, clamp them to the table, or use the fence provided with the drill press to brace the workpiece. Failure to secure the workpiece could result in personal injury.

Fig. AA

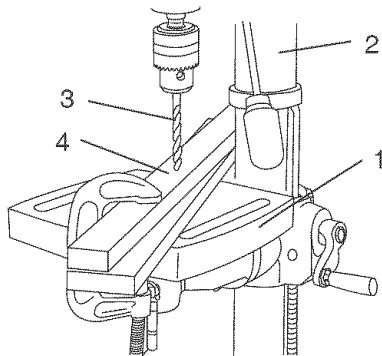

▲ WARNING

A drill press vise MUST be clamped or bolted to the table to avoid injury from a spinning workpiece, or damaged vise or bit parts.

Remove the drill press fence when it interferes with other drill press accessories.

Fig. BB

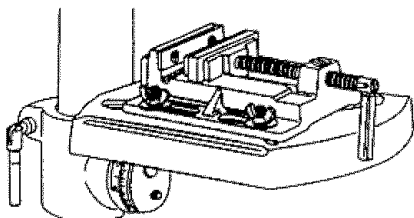

HOLDING A DRILLING LOCATION

1. Using a centerpunch or sharp nail, make an indentation in the workpiece where you will be drilling.

2. Turn the laser "ON" and align the laser lines (x) with the indentation before turning the drill ON.

TILTING THE TABLE (FIG. CC)

NOTE: The table arm and support (1) has a predrilled hole with a locking pin inserted for locking the table into a predrilled 0° bevel angle.

1. TIGHTEN the nut (2) on the locking pin using a 10mm or adjustable wrench clockwise to RELEASE it from the table support.
2. Loosen the large hex head table bevel locking bolt (3) using a 17mm or adjustable wrench.

▲ WARNING

To prevent injury, be sure to hold the table & table arm assembly, so it will not swivel or tilt.

Fig. CC

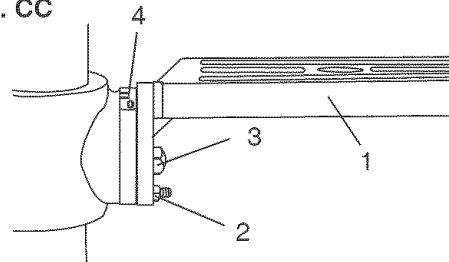

3. Tilt the table, aligning the desired angle measurement to the zero line opposite the scale (4).
4. Tighten the table bevel locking bolt (3).
5. To return the table to its original position, loosen the table bevel locking bolt (3). Return the table (1) to the 0° position.
6. Return nut (2) on locking pin to the OUTSIDE END OF THREADS. Gently tap locking pin until it is seated in the mating hole of the table bracket. Hand tighten nut (2).

▲ WARNING

To avoid injury from spinning work or tool breakage, always clamp workpiece and backup material securely to the table before operating the drill press.

FEEDING

1. Pull down the feed handles with only enough effort to allow the drill bit to cut.
2. Feeding too slowly might cause the drill bit to burn. Feeding too rapidly might cause the belt or drill to slip, tear the workpiece loose or break the drill bit.
3. When drilling metal, it is necessary to lubricate the drill bit tip with oil to prevent burning of the workpiece and bit.

MAINTENANCE

▲ WARNING

For your own safety, turn the switch OFF and remove the plug from the power source outlet before maintaining or lubricating your drill press.

Frequently blow out, using an air compressor or dust vacuum, any dust that accumulates inside the motor. Wear protective safety goggles.

▲ WARNING

To avoid shock or fire hazard, if the power cord is worn or cut in any way, have it replaced immediately.

LUBRICATION

All of the drill press ball bearings are packed with grease at the factory. They require no further lubrication.

Periodically lubricate the gear and rack, table elevation mechanism of the spindle the rack (teeth) of the quill.

CHANGING THE LASER BATTERIES (FIG. DD)

- Unplug your drill press.

▲ WARNING

Failure to unplug your tool could result in accidental starting causing possible serious personal injury.

1. Open the battery cover (1).
2. Remove and replace the two batteries.
3. Replace the battery cover.

NOTE: Replace the batteries with batteries that have a rating of 1.5 volts (Number 4 series and AAA size or equivalent). When replacing the batteries, the battery guide should be thoroughly cleaned. Use a soft paintbrush or similar device, to remove all sawdust and debris.

Fig. DD

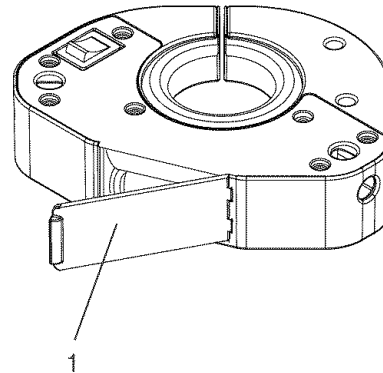

TROUBLESHOOTING GUIDE

WARNING

To avoid injury from accidental starting, always turn switch OFF and unplug the tool before moving, replacing the blade or making adjustments.

- Consult your Sears Service Center if for any reason the motor will not run.

PROBLEM	POSSIBLE CAUSES	REMEDY
Noisy operation	<ol style="list-style-type: none"> 1. Incorrect belt tension. 2. Dry spindle. 3. Loose spindle pulley. 4. Loose motor pulley. 	<ol style="list-style-type: none"> 1. Adjust tension. See section "ASSEMBLY-TENSIONING BELT" 2. Lubricate spindle. See Section "LUBRICATION". 3. Check tightness of retaining nut on pulley, and tighten if necessary. 4. Tighten set screw in motor pulley.
Drill bit burn.	<ol style="list-style-type: none"> 1. Incorrect speed. 2. Chips not coming out of hole. 3. Dull drill bit. 4. Feeding too slowly. 5. Not lubricated. 	<ol style="list-style-type: none"> 1. Change speed. See Section "BASIC DRILL PRESS OPERATION- SPINDLE SPEEDS" 2. Retract drill frequently to clear chips. 3. Resharpener drill bit. 4. Feed fast enough – allow drill to cut. 5. Lubricate drill. See Section "BASIC DRILL PRESS OPERATION-FEEDING"
Run out of drill bit point-drilled hole not round.	<ol style="list-style-type: none"> 1. Hand grain in wood or lengths of cutting flutes and/ or angles not equal. 2. Bent drill bit. 	<ol style="list-style-type: none"> 1. Resharpener drill bit correctly. 2. Replace drill bit.
Wood splinters on underside.	<ol style="list-style-type: none"> 1. No backup material under workpiece. 	<ol style="list-style-type: none"> 1. Use backup material. See Section "BASIC DRILL PRESS OPERATION".
Workpiece torn loose from hand.	<ol style="list-style-type: none"> 1. Not supported or clamped properly. 	<ol style="list-style-type: none"> 1. Support workpiece or clamp it. See Section "BASIC DRILL PRESS OPERATION".
Drill bit binds in workpiece.	<ol style="list-style-type: none"> 1. Workpiece pinching drill bit, or excessive feed pressure. 2. Improper belt tension. 	<ol style="list-style-type: none"> 1. Support workpiece or clamp it. See Section "BASIC DRILL PRESS OPERATION". 2. Adjust tension. See Section "ASSEMBLY – TENSIONING BELT".
Excessive drill bit runout or wobble.	<ol style="list-style-type: none"> 1. Bent drill bit. 2. Worn bearings. 3. Drill bit not properly installed in chuck. 4. Chuck not properly installed. 	<ol style="list-style-type: none"> 1. Use a straight drill bit. 2. Replace bearings. 3. Install drill properly. See Section "BASIC DRILL PRESS OPERATION" and "ASSEMBLY". 4. Install chuck properly. See Section "ASSEMBLY – INSTALLING THE CHUCK".
Quill returns too slow or too fast.	<ol style="list-style-type: none"> 1. Coil spring has improper tension. 	<ol style="list-style-type: none"> 1. Adjust spring tension. See Section "ASSEMBLY – ADJUSTMENTS –QUILL RETURN SPRING".
Chuck will not stay attached to spindle. It falls off when trying to install.	<ol style="list-style-type: none"> 1. Dirt, grease, or oil on the tapered inside surface of chuck or on the spindle's tapered surface. 	<ol style="list-style-type: none"> 1. Using a non-alcohol based cleaner, clean the tapered surface of the chuck and spindle to remove all dirt, grease and oil. See Section "ASSEMBLY – INSTALLING THE CHUCK".
The laser guide will not turn on.	<ol style="list-style-type: none"> 1. The batteries are dead. 2. The battery contacts need adjustment. 	<ol style="list-style-type: none"> 1. Replace with new AAA batteries. 2. Tap outside the bottom and side of the laser housing lightly with the but end of a screwdriver.

PARTS LIST

10 in. DRILL PRESS

MODEL NO. 137.219000

▲ WARNING

When servicing use only CRAFTSMAN replacement parts. Use of any other parts may create a HAZARD or cause product damage.

▲ WARNING

Any attempt to repair or replace electrical parts on this Drill Press may create a HAZARD unless repair is done by a qualified service technician. Repair service is available at your nearest Sears Service Center.

PARTS LIST FOR SCHEMATIC

I.D. NO.	DESCRIPTION	SIZE	QTY	I.D. NO.	DESCRIPTION	SIZE	QTY
047U	SET BOLT	M10*1.5	1	OKFF	CR. RE. PAN HD. SCREW	M5*0.8-8	2
047X	POINTER		1	OKMS	HEX. NUT	M6*1.0 T=5	1
048K	MOTOR ROD		1	OKMY	HEX. NUT	M8*1.25 T=6.5	5
048P	FEED SHAFT		1	OKPC	HEX. NUT	3/8*24UNF T=8	2
048Z	HANDLE BAR ASS'Y		1	OKQY	LOCK NUT	M8*1.25 T=8	2
0499	SPRING CAP ASS'Y		1	OKSQ	STRAIN RELIEF		2
049C	QUILL SET SCREW	M8*1.25-14	1	OKUX	TERMINAL		1
049S	SPINDLE PULLEY	#06	1	OL6D	POWER CABLE		1
049Z	MOTOR PULLEY ASS'Y		1	OLSC	ROCKER SWITCH		1
04A5	CLAMP-CORD		3	OLWC	ROCKER SWITCH		1
04AD	SWITCH BOX		1	OSYV	LOCATION PIN ASS'Y		1
04BM	SWITCH COVER		1	OUGH	DRIVING SLEEVE ASS'Y		1
04Q4	STICKER		1	OV86	WARNING LABEL		1
04VT	WORM		1	OV8A	CHUCK KEY		1
04WG	SPRING		1	OVND	HEAD	#AW	1
04WN	MOTOR BASE		1	OVPE	SPEED DIAGRAM		1
04XV	PULLEY SET NUT		1	OWPL	SWITCH KEY		1
05SZ	CHUCK KEY HOLDER		1	OXF3	CRANK HANDLE ASS'Y		1
05TW	NUT		2	25B0	WARNING LABEL		1
05VD	TABLE LOCK HANDLE	M10*1.5-25	1	25KA	LASER STICKER		2
05X8	SHIFTER BOLT	M8*1.25-20	1	266Z	PLUNGER HOUSING ASS'Y		2
06SV	CLAMP-CORD		1	26AN	LASER ASS'Y		1
0J2J	CHUCK & KEY		1	28N2	BATTERIES		1
0J3M	HEX. WRENCH	3 mm	1	290M	CAUTION LABEL		1
0J3P	HEX. WRENCH	4 mm	1	29FK	CLEAR PANEL		2
0J4F	FLAT WASHER	φ8X16-2.5	8	29KU	PULLEY COVER ASS'Y	#06	1
0J72	FLAT WASHER	1/4*5/8-1/16	1	29L4	RACK		1
0J8F	FLAT WASHER	1/4*3/4-3/16	4	29R0	RACK RING ASS'Y		1
0J7F	FLAT WASHER	5/16*7/8-5/64	2	29R1	TABLE BRACKET ASS'Y		1
0JAF	EXTERNAL TOOTH LOCK WASHER	φ5	2	2A2F	FENCE HARDWARE BAG ASS'Y		1
0JCB	SPRING PIN		1	2A7V	QUILL ASS'Y		1
0JJZ	V-BELT		1	2ARX	BASE	#06	1
0JP4	HEX. HD. BOLT	M8*1.25-16	4	2AS1	TABLE	#AW	1
0JQ7	HEX. HD. BOLT	M8*1.25-25	6	2AUB	SCALE		1
0JTA	HEX. HD. BOLT	1/2*12UNC-7/8	1	2B0Y	OPERATOR'S MANUAL		1
0JXE	HEX. SOC. SET SCREW	M8*1.25-8	3	2B7K	COLUMN ASS'Y		1
OK51	CR. RE. COUNT HD. SCREW	M4*0.7-8	4	2BJ1	MOTOR ASS'Y		1
OK7K	CR. RE. ROUND WASHER HD. SCREW	M6*1.0-12	5	2C05	TRADE-MARK LABEL		1
OK9X	DRIVE SCREW	φ2.3-5	4	2C06	LABEL		1
OKC6	CR. RE. TRUSS HD. TAPPING SCREW	M4*16-12	2	2C07	SCALE		1
OKDH	CR. RE. PAN HD. SCREW	M5*0.8-8	3	2C08	SPEED DIAGRAM		1
OKDJ	CR. RE. PAN HD. SCREW	M5*0.8-12	3				

10 in. DRILL PRESS SCHEMATIC

MODEL NO. 137.219000

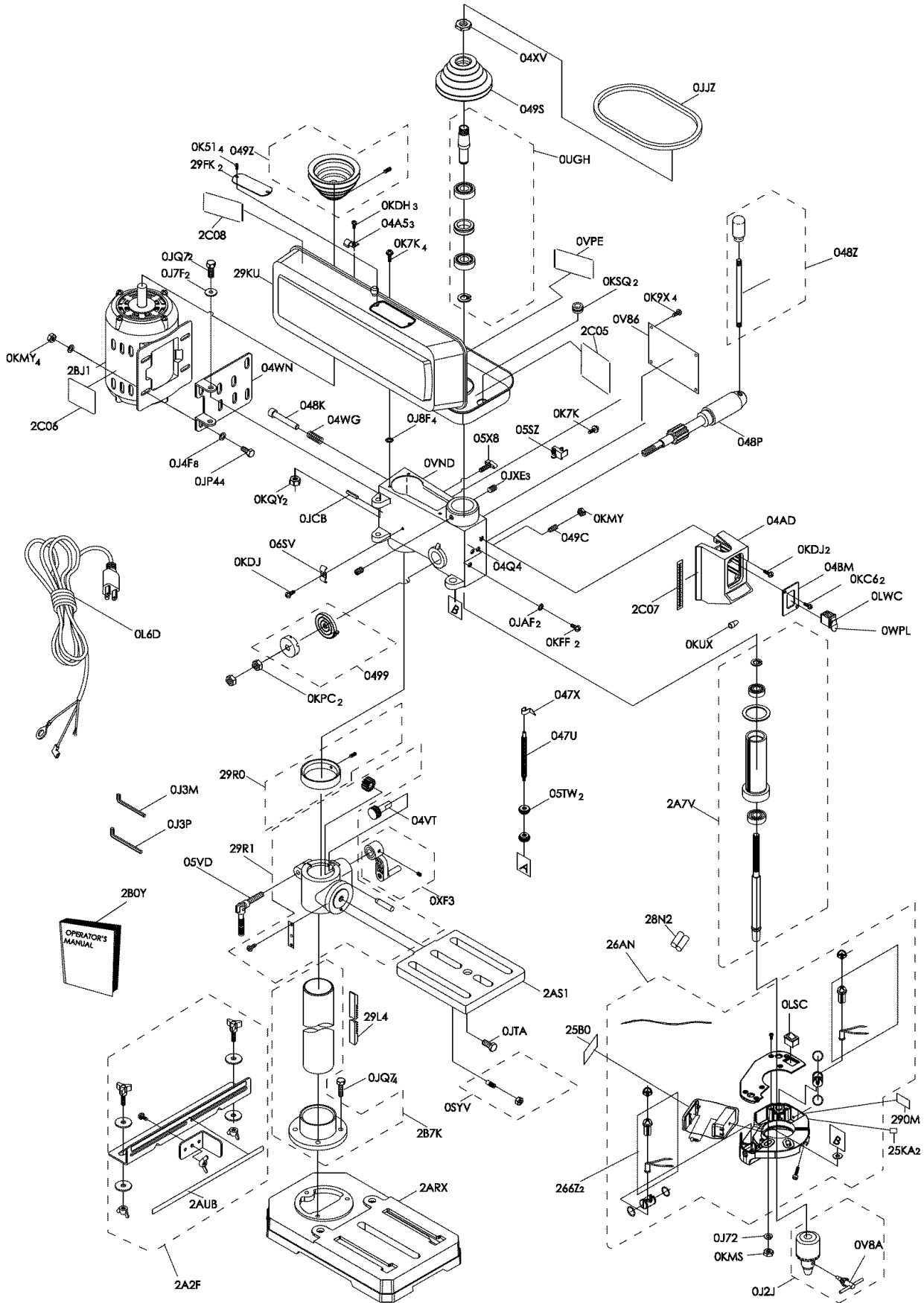

Get it fixed, at your home or ours!

Your Home

For repair – **in your home** – of all major brand appliances, lawn and garden equipment, or heating and cooling systems, **no matter who made it, no matter who sold it!**

For the replacement parts, accessories and Operator's Manuals that you need to do-it-yourself. For Sears professional installation of home appliances and items like garage door openers and water heaters.

1-800-4-MY-HOME[®] (1-800-469-4663)

Call anytime, day or night (U.S.A. and Canada)

www.sears.com www.sears.ca

Our Home

For repair of carry-in items like vacuums, lawn equipment, and electronics, call or go on-line for the location of your nearest **Sears Parts & Repair Center.**

1-800-488-1222

Call anytime, day or night (U.S.A. only)

www.sears.com

To purchase a protection agreement on a product serviced by Sears:

1-800-827-6655 (U.S.A.)

1-800-361-6665 (Canada)

Para pedir servicio de reparación a domicilio, y para ordenar piezas:

1-888-SU-HOGARSM

(1-888-784-6427)

Au Canada pour service en français:

1-800-LE-FOYER^{MD}

(1-800-533-6937)

www.sears.ca

SEARS

© Registered Trademark / TM Trademark / SM Service Mark of Sears, Roebuck and Co.

© Marca Registrada / TM Marca de Fábrica / SM Marca de Servicio de Sears, Roebuck and Co.

MC Marque de commerce / MD Marque déposée de Sears, Roebuck and Co.

© Sears, Roebuck and Co.

2005. 10. REV 2

Free Manuals Download Website

<http://myh66.com>

<http://usermanuals.us>

<http://www.somanuals.com>

<http://www.4manuals.cc>

<http://www.manual-lib.com>

<http://www.404manual.com>

<http://www.luxmanual.com>

<http://aubethermostatmanual.com>

Golf course search by state

<http://golfingnear.com>

Email search by domain

<http://emailbydomain.com>

Auto manuals search

<http://auto.somanuals.com>

TV manuals search

<http://tv.somanuals.com>