

Owner's Manual



DETHATCHER FOR SWEEPERS

Model No. 486.24218

DO NOT RETURN TO STORE
For Missing Parts or Assembly
Questions Call 1-866-576-8388

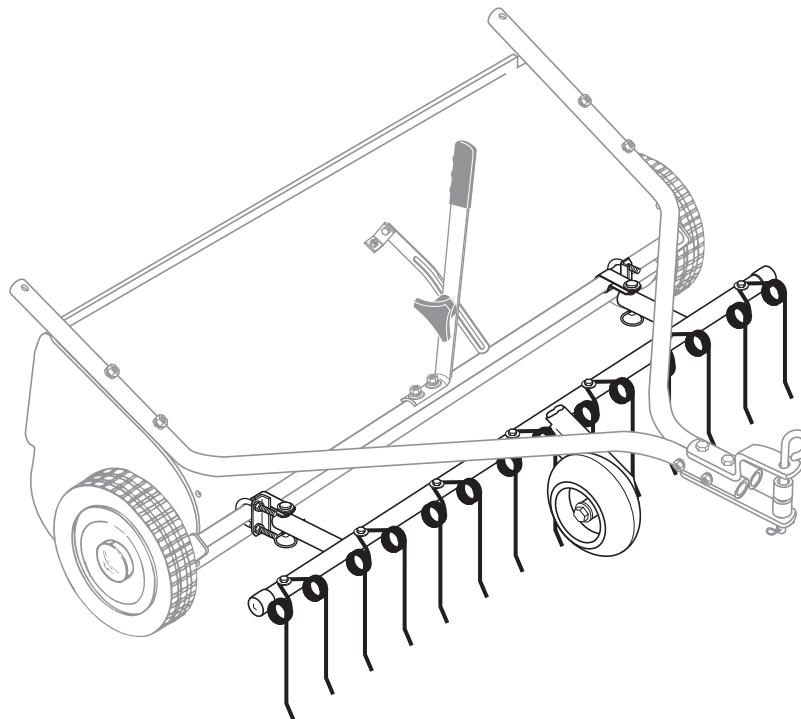

CAUTION:

Before using this product, read this manual and follow all Safety Rules and Operating Instructions.

- Safety
- Assembly
- Operation
- Maintenance
- Parts

Sears, Roebuck and Co., Hoffman Estates, IL 60179 U.S.A.
www.sears.com/craftsman

PRINTED IN U.S.A.

FORM NO. 41268 (7-21-09)

TABLE OF CONTENTS

SAFETY RULES.....	2	OPERATION.....	7
FULL SIZE HARDWARE CHART.....	3	MAINTENANCE/STORAGE.....	7
CARTON CONTENTS.....	4	REPAIR PARTS.....	9
ASSEMBLY.....	4	PARTS ORDERING/SERVICE.....	Back Page

WARRANTY

CRAFTSMAN FULL WARRANTY

When operated and maintained according to all supplied instructions, if this Craftsman product fails due to a defect in material or workmanship within one year from the date of purchase, return it to any Sears store or other Craftsman outlet in the United States for free replacement.

This warranty applies for only 90 days from the date of purchase if this product is ever used for commercial or rental purposes.

This warranty does not include items considered to be expendable parts that can wear out from normal use within the warranty period.

This warranty gives you specific legal rights, and you may also have other rights which vary from state to state.

Sears, Roebuck and Co., D817WA, Hoffman Estates, IL 60179

DO NOT RETURN TO STORE for Missing Parts or Assembly Questions
Call 1-866-576-8388 Attachment Hotline

<p>The model number and serial numbers will be found on a decal attached to the dethatcher.</p> <p>You should record both the serial number and the date of purchase and keep in a safe place for future reference.</p>	<p>MODEL NUMBER: 486.24218</p> <p>SERIAL NUMBER: _____</p> <p>DATE OF PURCHASE: _____</p>
---	---



SAFETY



Any power equipment can cause injury if operated improperly or if the user does not understand how to operate the equipment. Exercise caution at all times, when using power equipment.

- Read this owners manual carefully for operating and service instructions before attempting to assemble or operate the dethatcher. Be thoroughly familiar with the proper use of the dethatcher.
 - Read the vehicle owners manual and vehicle safety rules, and know how to operate the vehicle before using the dethatcher.
 - Read the lawnsweeper owners manual and safety rules, and know how to operate the lawnsweeper before using the dethatcher.
 - Never allow children to operate the tractor or dethatcher attachment, and do not allow adults to operate without proper instructions.
 - This dethatcher attachment has sharp tine points. Always handle with care and wear substantial foot wear when operating this dethatcher.
 - Do not allow anyone to ride or sit on the dethatcher, lawnsweeper or towing vehicle.
 - Keep the area of operation clear of all persons, particularly small children, and also pets.
- Always begin with the transmission in first (low) gear and engine at low speed, and gradually increase speed as conditions permit.
 - Vehicle braking and stability may be affected with the attachment of this equipment. Be aware of changing conditions on slopes. Refer to safety rules in the vehicle owner's manual concerning safe operation on slopes. **STAY OFF OF STEEP SLOPES.**
 - Always operate up and down a slope, never across the face of a slope
 - This equipment should be operated at reduced speed on rough terrain, along creeks and ditches and on hillsides, to prevent tipping and loss of control. Do not drive too close to a creek or a ditch.
 - Follow the maintenance instructions as outlined in this owners manual.

Look for this symbol to point out important safety precautions. It means — **Attention!!**
Become alert!! Your safety is involved.

HARDWARE PACKAGE CONTENTS

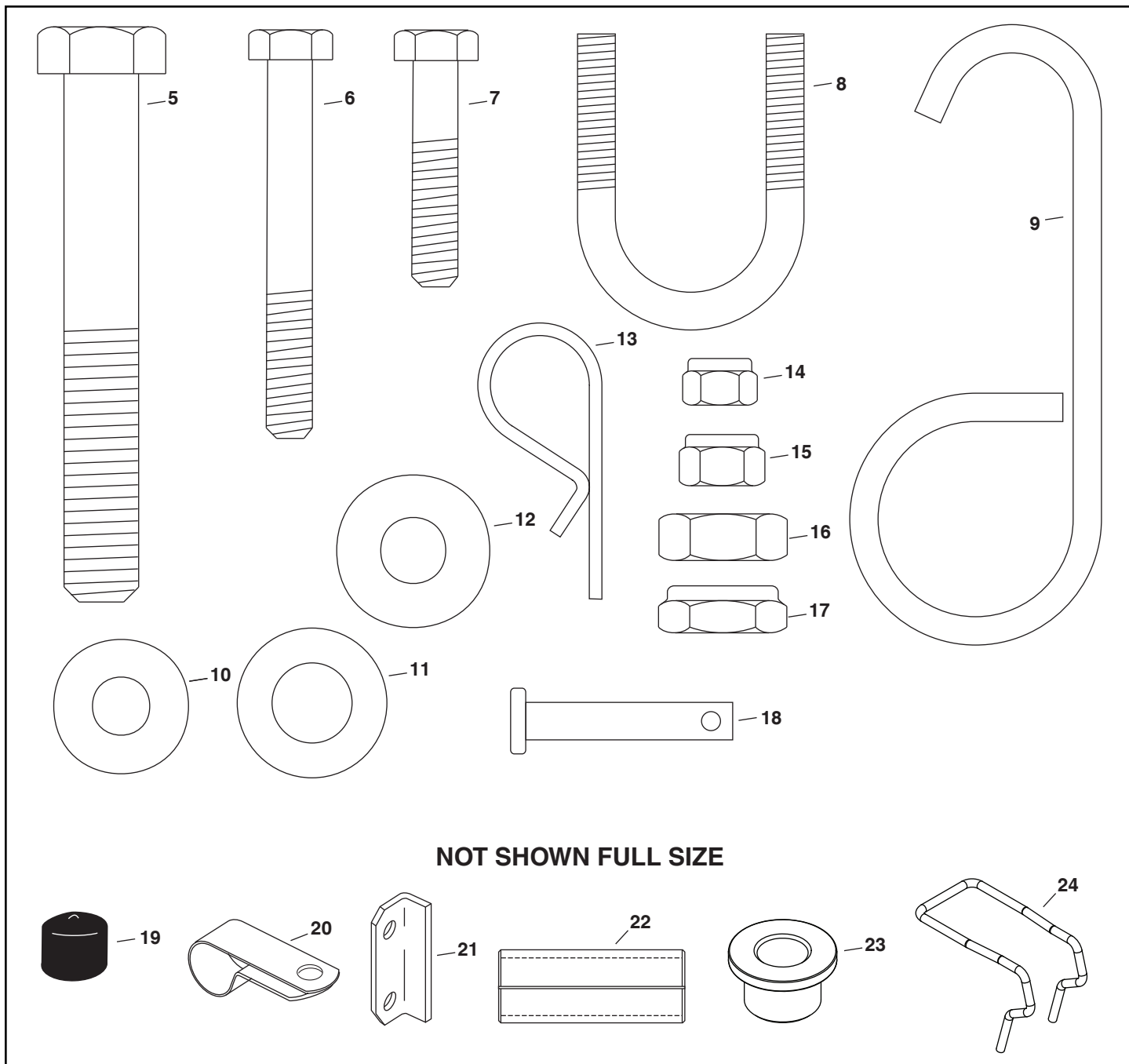

NOT SHOWN FULL SIZE

REF.	PART NO.	QTY.	DESCRIPTION	REF.	PART NO.	QTY.	DESCRIPTION
5	46526	3	Hex Bolt, 1/2-13 x 3-1/2"	15	47810	9	Nylock Nut, 5/16-18
6	44292	2	Hex Bolt, 5/16-18 x 2-1/2"	16	43019	1	Jam Nut, Plain 1/2-13
7	43085	7	Hex Bolt, 5/16-18 x 1-1/2"	17	48115	3	Jam Nut, Nylock 1/2-13
8	48813	2	U-Bolt, 1/4-20	18	48812	2	Clevis Pin, 5/16" x 1-3/8"
9	48811	1	Transport Hook	19	44481	2	Vinyl Cap
10	43081	2	Washer, 5/16"	20	48917	2	Clamp
11	R19171616	2	Washer, 1/2"	21	25054	2	Bracket, U-Bolt Clamp
12	43070	14	Washer, 3/8"	22	46499	2	Spacer
13	43055	2	Hair Cotter Pin, 3/32"	23	741-0248	4	Flange Bearing
14	47189	4	Nylock Nut, 1/4-20	24	42212	1	Double Transport Hook

ASSEMBLY

CARTON CONTENTS

1. Spring Tines (7)
2. Frame Assembly
3. Gauge Wheel
4. Mount Brackets (2)

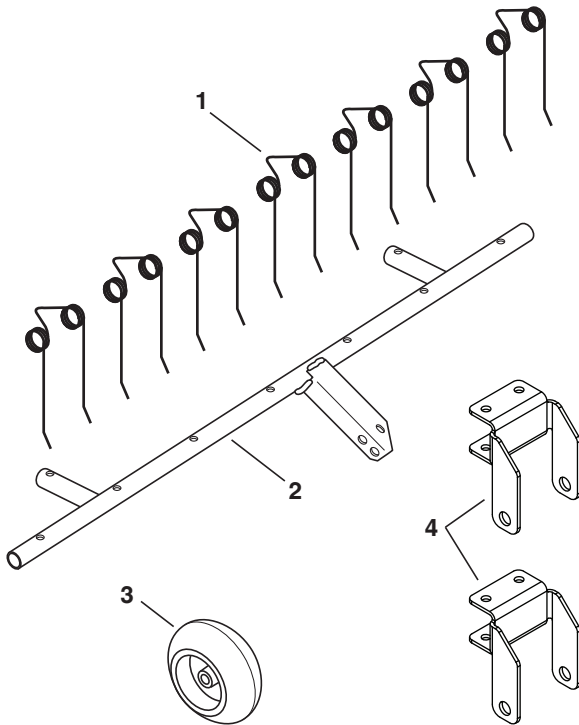

NOTE: On sweepers smaller than 42", use only five spring tines.

- Assemble a vinyl cap onto each end of the frame tube. See figure 1.

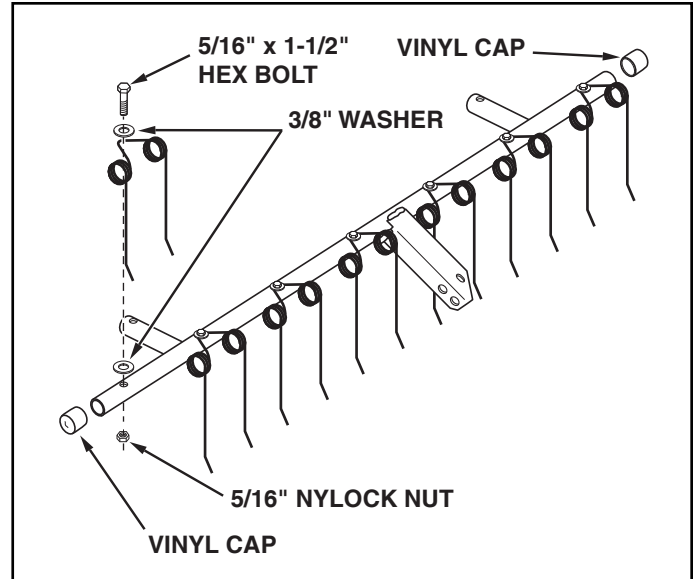

FIGURE 1

- Assemble a 1/2" washer, the wheel, another 1/2" washer and the 1/2" plain jam nut onto the 1/2" x 3-1/2" hex bolt. See figure 2.
- Insert the bolt through the welded bracket and assemble the 1/2" nylock jam nut onto the bolt. Adjust the nuts so that there is no end play in the wheel and then tighten the nuts securely against the welded bracket. Make sure the wheel still turns freely. See figure 2.

TOOLS REQUIRED FOR ASSEMBLY

- (1) 7/16" Wrench
- (2) 1/2" Wrenches
- (2) 3/4" or Adjustable Wrenches
- (1) Knife

REMOVAL OF PARTS FROM CARTON

- Remove all parts and hardware packages from the carton. Lay out all parts and hardware and identify using the illustrations on pages 3 and 4.
- Turn the frame assembly as shown in figure 1.
- Assemble seven spring tines to the top of the frame tube. Use a 5/16" x 1-1/2" hex bolt, two 3/8" flat washers and a 5/16" nylock nut for each spring tine. Place one 3/8" flat washer on top of the frame tube and the second 3/8" flat washer on top of the spring tine. See figure 1.

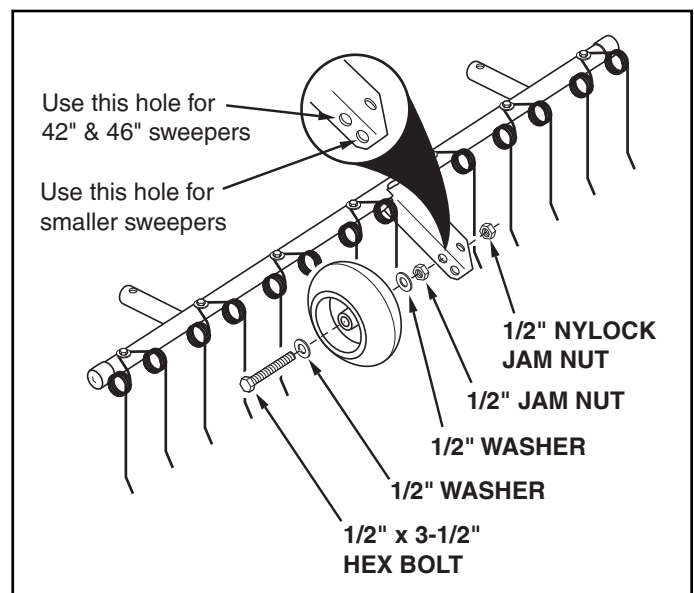

FIGURE 2

SWEEPERS WITH TWO HITCH TUBES

Skip to page 6 for sweepers with single hitch tubes.

- Assemble a conduit clamp onto each end of the sweeper height adjustment tube so that the straight part of the clamp is on top of the tube.
- Remove the hitch brackets from the sweeper's hitch tubes. Slide the transport hook onto the L.H. hitch tube as shown in figure 3.
- Reassemble the hitch brackets and bolts to the hitch tubes. Refer to your sweeper owner's manual.

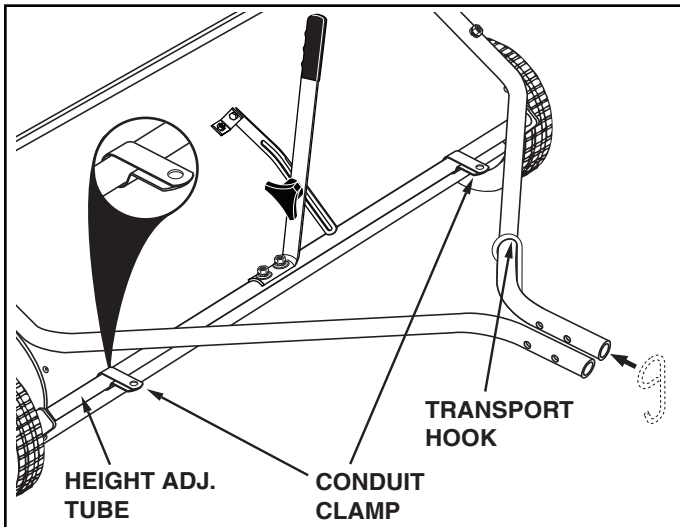

FIGURE 3

- Connect the sweeper to the tractor. Set the sweeper height adjustment handle to about the middle of its adjustment range.
- Place the dethatcher in front of the sweeper housing, underneath the hitch tubes.
- Connect the dethatcher to the conduit clamps using two 5/16" x 1-3/8" clevis pins, 5/16" washers and 3/32" hair cotter pins. See figure 4.

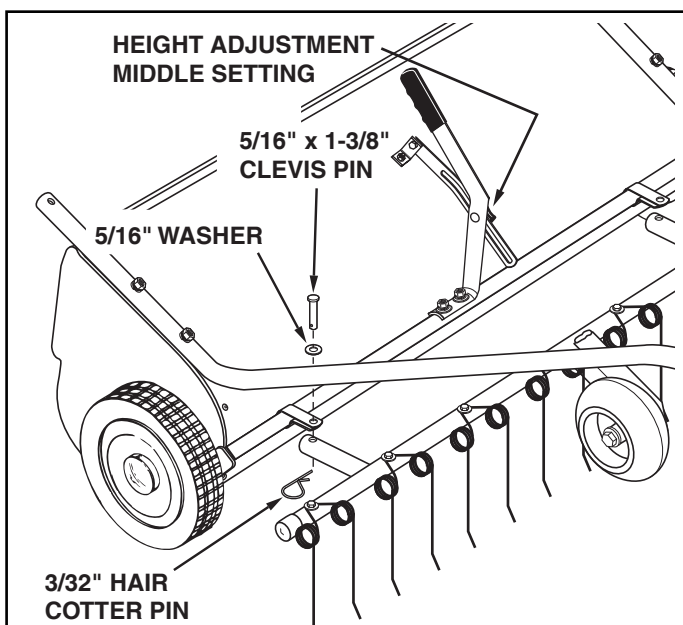

FIGURE 4

If you have a 30" sweeper, skip to figure 6.

- Make sure the sweeper height adjustment handle is still set to about the middle of its adjustment range.
- Center the dethatcher with the sweeper.
- Assemble the keeper brackets (bend to the inside) to the sweeper's hitch tube, outside of the conduit clamps. Use a u-bolt and two 1/4" nylock nuts per bracket. Position the keeper brackets against the sides of the conduit clamps, approximately perpendicular to the ground. Tighten the nuts without bending the keeper brackets. See figure 5.

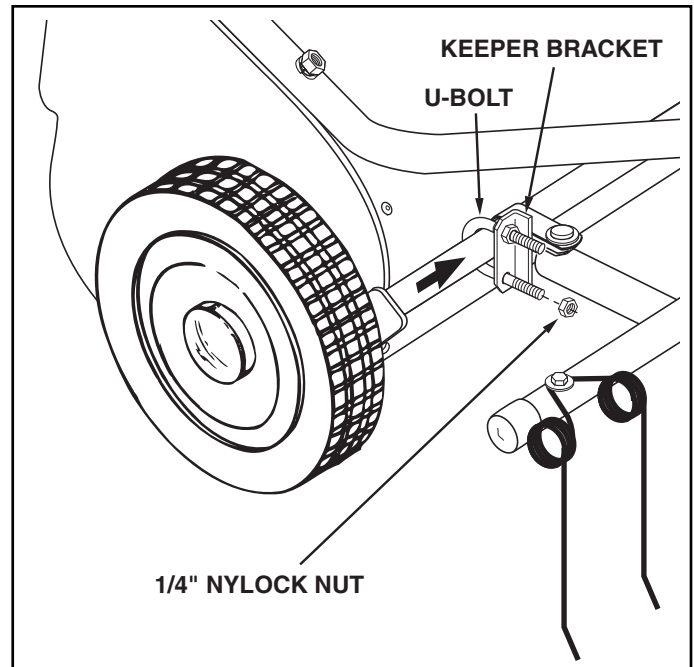

FIGURE 5

- Lift the front of the dethatcher and secure it in transport position using the transport hook. See figure 6.
- To keep the transport hook from sliding back along the hitch tube, you can fasten the supplied nylon tie around the hitch tube behind the transport hook. See figure 6.

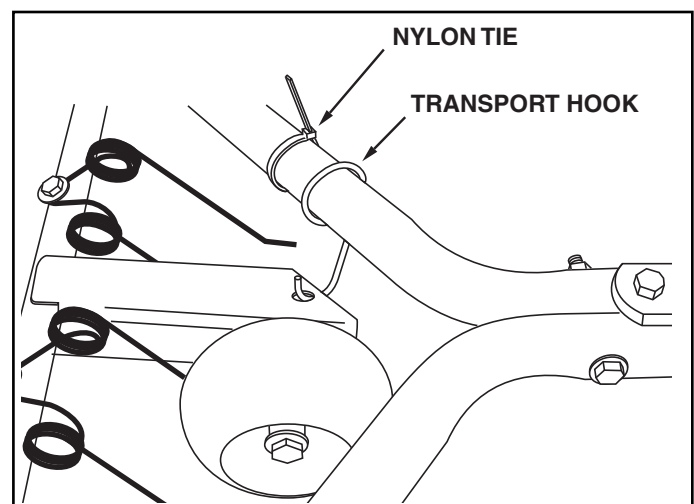

FIGURE 6

SWEEPERS WITH A SINGLE HITCH TUBE

NOTE: The dethatcher attaches to the sweeper's offset tube. This prevents you from offsetting the sweeper.

- Assemble the four bearings to the two spacers and then slide each through a clamp.

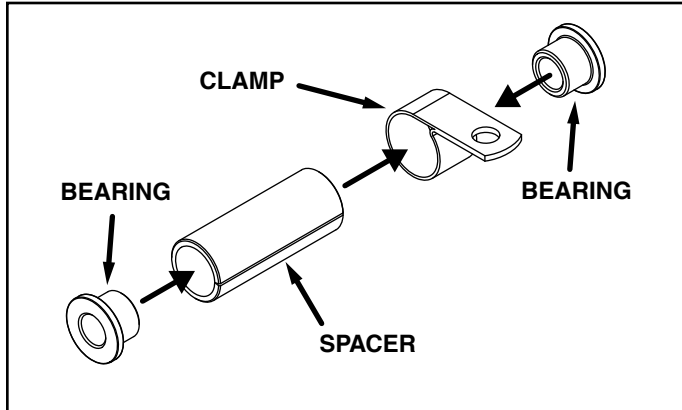

FIGURE 7

- Attach each of the bearing, spacer, and clamp assemblies to a mount bracket using a 1/2 x 3-1/2" hex bolt and 1/2" nylock jam nut.

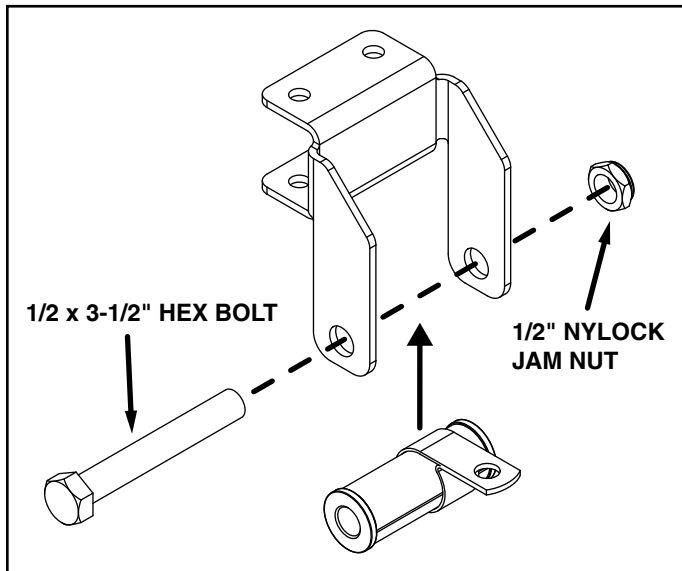

FIGURE 8

- Fasten each clamp to the spring mount frame assembly using one 5/16 x 1-3/8" clevis pin, 5/16" washer, and 3/32" hair cotter pin.

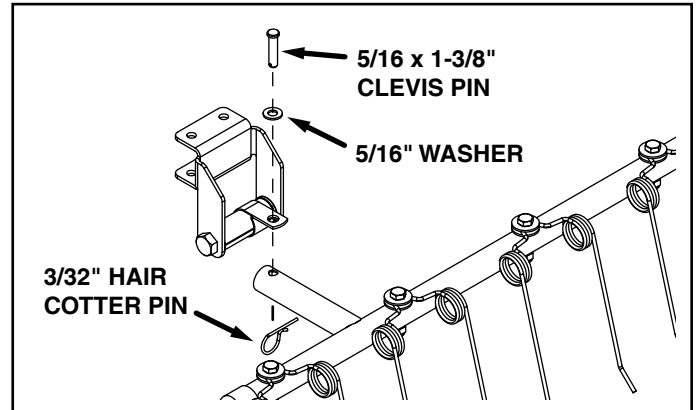

FIGURE 9

- Secure the two mount brackets to the inner holes of the drawbar offset tube of the sweeper using two 5/16 x 2-1/2" hex bolts and 5/16" nylock nuts.

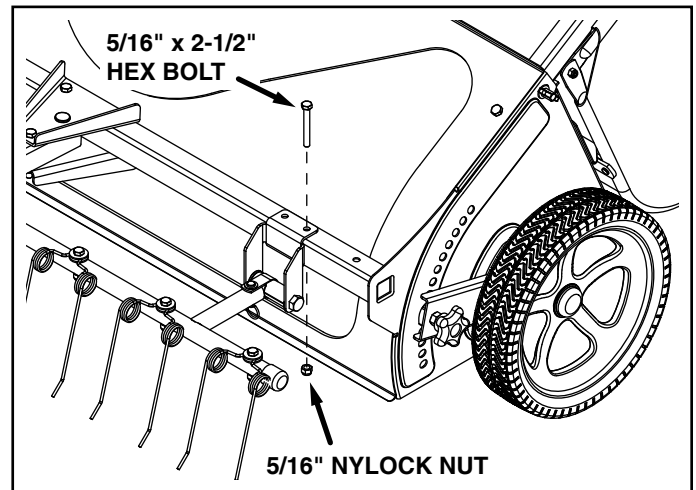

FIGURE 10

- Place the double transport hook onto the sweeper hitch tube. Lift up the front of the dethatcher and slide it into the double hooks to secure it in the transport position.

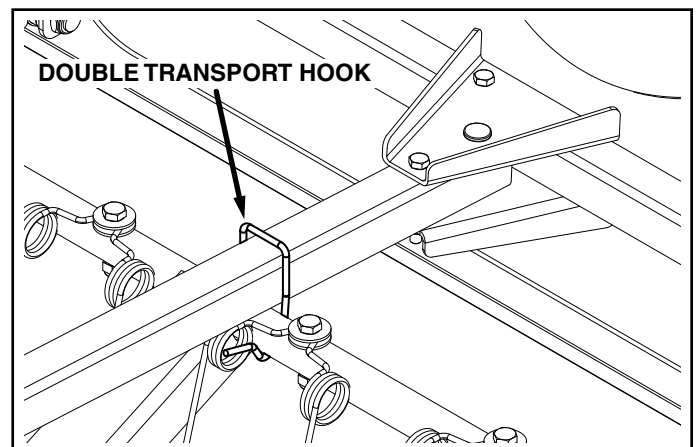

FIGURE 11

OPERATION

HOW TO USE YOUR DETHATCHER

RAISING/LOWERING THE DETHATCHER

- To raise the dethatcher for transport, lift up on the front of the dethatcher and secure it with the transport hook. Lower the dethatcher by releasing the transport hook.

SETTING THE OPERATING POSITION

- The operating height of the dethatcher is controlled by the gauge wheel at the front of the dethatcher and is not adjustable. The correct wheel position was determined in figure 2 when you assembled the wheel.
- Set the sweeper to the desired operating height. (The best height is usually with the brushes set about 1/2" down into the grass.) Refer to your sweeper owner's manual.

USING THE DETHATCHER

Regular removal of thatch is critical to the maintenance of a healthy lawn. Thatch is layer of stems, clippings, runners, roots and leaves that have not decayed. Excessive thatch prevents air, water and fertilizer from reaching the roots. The dethatcher will effectively dislodge excessive thatch from your lawn.

- Start with the tractor in low gear. Vary the forward speed to determine the best speed for maximum dethatcher performance.
- Use a crisscross pattern to achieve the most even removal of thatch.
- On slopes, always operate in an up and down direction only.
- Avoid extremely sharp turns.
- Avoid towing the dethatcher across sudden steep dips in the ground while dethatching. Loss of ground contact with the gauge wheel could cause the dethatcher to be pulled back underneath the sweeper.

MAINTENANCE / STORAGE

CUSTOMER RESPONSIBILITIES

- Read and follow the maintenance schedule and the maintenance procedures listed in this section.

MAINTENANCE SCHEDULE Fill in dates as you complete regular service.	Service Dates												
	Before each use	After each use	Every season	Before storage									
Check for loose fasteners	X												
Check for worn or damaged parts	X			X									
Cleaning		X		X									

- Before each use, check all nuts and bolts for tightness.
- Clean after each use to help prevent rust.
- If rust appears on the spring tines, sand lightly and coat with enamel paint.
- Always store in a dry area, and coat exposed metal with light oil when not in use.

NOTES

PARTS

REPAIR PARTS FOR MODEL 486.24218 DETHATCHER

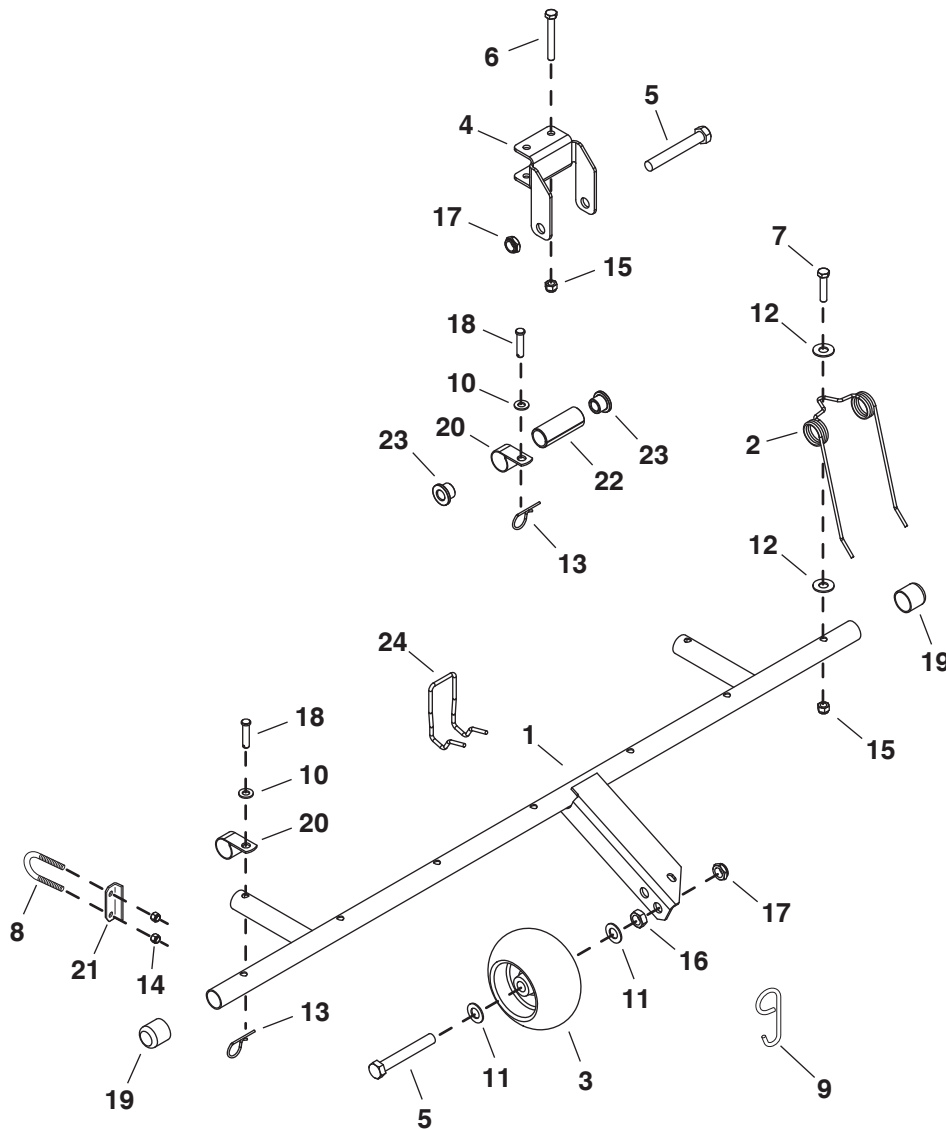

REF.	PART NO.	QTY.	DESCRIPTION	REF.	PART NO.	QTY.	DESCRIPTION
1	64650	1	Spring Mount Frame Assem.	14	47189	4	Nylock Nut, 1/4-20
2	46761	7	Spring Tine	15	47810	9	Nylock Nut, 5/16-18
3	48098	1	Gauge Wheel	16	43019	1	Jam Nut, Plain 1/2-13
4	26624	2	Mount Bracket	17	48115	3	Jam Nut, Nylock 1/2-13
5	46526	3	Hex Bolt, 1/2-13 x 3-1/2"	18	48812	2	Clevis Pin, 5/16" x 1-3/8"
6	44292	2	Hex Bolt, 5/16-18 x 2-1/2"	19	44481	2	Vinyl Cap
7	43085	7	Hex Bolt, 5/16-18 x 1-1/2"	20	48917	2	Clamp
8	48813	2	U-Bolt, 1/4-20	21	25054	2	Bracket, U-Bolt Clamp
9	48811	1	Hook, Transport	22	46499	2	Spacer
10	43081	2	Washer, 5/16"	23	741-0248	4	Flange Bearing
11	R19171616	2	Washer, 1/2"	24	42212	1	Hook (Double Transport)
12	43070	14	Washer, 3/8"		41268	1	Owner's Manual
13	43055	2	Hair Cotter Pin, 3/32"				

Get it fixed, at your home or ours!

Your Home

For expert troubleshooting and home solutions advice:

manage my home

www.managemyhome.com

For repair – **in your home** – of **all** major brand appliances, lawn and garden equipment, or heating and cooling systems, **no matter who made it, no matter who sold it!**

For the replacement parts, accessories and owner's manuals that you need to do-it-yourself.

For Sears professional installation of home appliances and items like garage door openers and water heaters.

1-800-4-MY-HOME® (1-800-469-4663)

Call anytime, day or night (U.S.A. and Canada)

www.sears.com www.sears.ca

Our Home

For repair of carry-in items like vacuums, lawn equipment, and electronics, call anytime for the location of your nearest

Sears Parts & Repair Service Center

1-800-488-1222 (U.S.A.) 1-800-469-4663 (Canada)

www.sears.com

www.sears.ca

To purchase a protection agreement on a product serviced by Sears:

1-800-827-6655 (U.S.A.)

1-800-361-6665 (Canada)

Para pedir servicio de reparación a domicilio, y para ordenar piezas:

1-888-SU-HOGAR®

(1-888-784-6427)

Au Canada pour service en français:

1-800-LE-FOYER^{MC}

(1-800-533-6937)

www.sears.ca



® Registered Trademark / ™ Trademark / ™ Service Mark of Sears Brands, LLC

® Marca Registrada / ™ Marca de Fábrica / ™ Marca de Servicio de Sears Brands, LLC

MC Marque de commerce / MD Marque déposée de Sears Brands, LLC

© Sears Brands, LLC

Free Manuals Download Website

<http://myh66.com>

<http://usermanuals.us>

<http://www.somanuals.com>

<http://www.4manuals.cc>

<http://www.manual-lib.com>

<http://www.404manual.com>

<http://www.luxmanual.com>

<http://aubethermostatmanual.com>

Golf course search by state

<http://golfingnear.com>

Email search by domain

<http://emailbydomain.com>

Auto manuals search

<http://auto.somanuals.com>

TV manuals search

<http://tv.somanuals.com>