

SEARS OWNER'S MANUAL

MODEL NO.
580.327270

PORTABLE GENERATOR
CUSTOMER
HELPLINE
1-800-222-3136

HOURS:
Mon. - Fri. 8 a.m. to 5 p.m.
(CST)

CAUTION:
Read and Follow
all Safety Rules
and Instructions
Before Operating
This Equipment

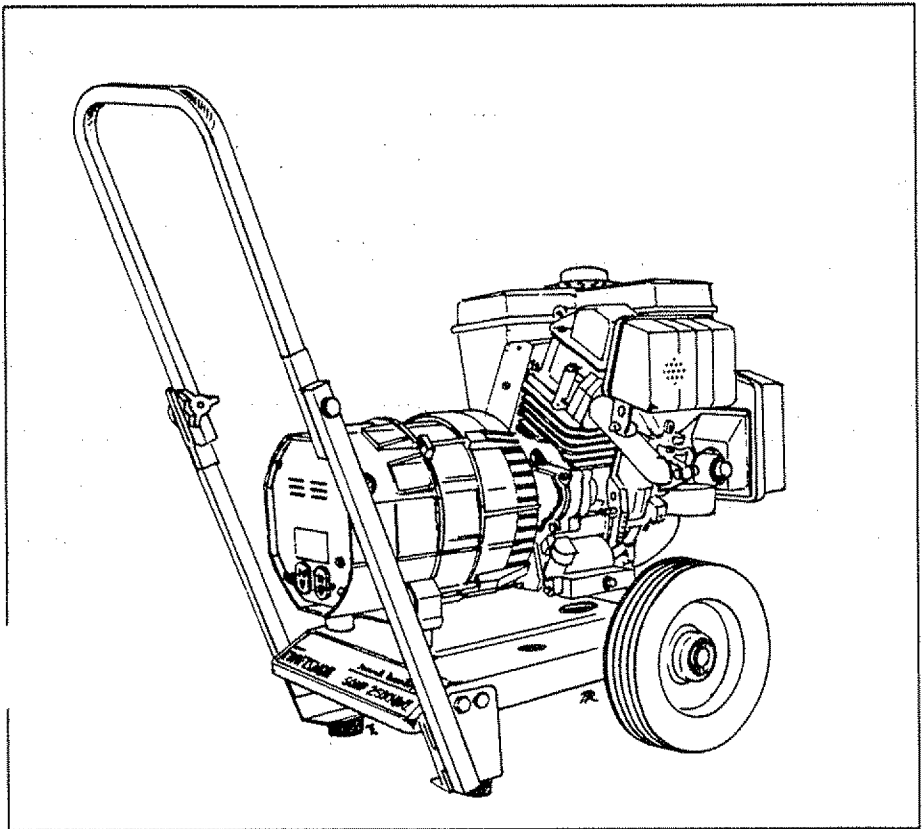

CRAFTSMAN® 120 VOLT / 2500 WATT A-C GENERATOR

- Assembly
- Operation
- Customer Responsibilities
- Service and Adjustment
- Repair Parts

SEARS, ROEBUCK and CO., Hoffman Estates, IL 60179 U.S.A.

SAFETY RULES



CAUTION: ALWAYS DISCONNECT SPARK PLUG WIRE AND PLACE WIRE WHERE IT CANNOT CONTACT SPARK PLUG, TO PREVENT ACCIDENTAL STARTING WHEN SETTING UP, TRANSPORTING, ADJUSTING OR MAKING REPAIRS TO YOUR GENERATOR.



IMPORTANT

THIS GENERATOR IS DESIGNED FOR OUTDOOR USE ONLY. USING THIS GENERATOR INSIDE ANY BUILDING OR ENCLOSURE, INCLUDING THE GENERATOR COMPARTMENT OF A RECREATIONAL VEHICLE (RV), IS DANGEROUS. FIRE OR AN EXPLOSION MAY RESULT. NO USER PERFORMED MODIFICATIONS, INCLUDING VENTING OF EXHAUST AND/OR COOLING VENTILATION, WILL ELIMINATE THE DANGER.

- If this unit is used for backup power in the event of a utility power failure, take the following steps: BEFORE CONNECTING THE GENERATOR TO AN ELECTRICAL SYSTEM OPEN THE MAIN CIRCUIT BREAKER OR MAIN SWITCH SERVING THE SYSTEM TO ISOLATE THE GENERATOR SYSTEM FROM THE ELECTRIC UTILITY. FAILURE TO ISOLATE THE GENERATOR AND UTILITY SYSTEMS MAY RESULT IN DAMAGE TO THE GENERATOR AND MAY ALSO RESULT IN INJURY OR DEATH TO ELECTRIC UTILITY WORKERS DUE TO BACKFEED OF ELECTRICAL ENERGY.
- This generator supplies dangerously high electrical voltages. Use care to prevent extremely hazardous and possibly lethal electrical shock. Never permit any unqualified person(s) to operate or service the unit.
- DO NOT operate this equipment in the rain, while standing in water, while barefoot, or while hands or feet are wet. Dangerous electrical shock will result.
- The spark arrestor muffler can become extremely hot. DO NOT operate this equipment in areas where combustible material such as grass, leaves or paper products can come in contact with the muffler.
- Maintain all wiring, extension cords, etc., in good condition. Worn, bare, frayed, or otherwise damaged wiring and cord sets may cause dangerous electrical shock and may also result in damage to equipment and/or property.
- The National Electrical Code requires that the generator be properly connected to an approved earth ground. Local electrical codes may also require proper grounding of the unit. See ASSEMBLY section for more grounding information.
- Wire gauge sizes of wiring and cord sets must be large enough to handle the maximum electrical load to which they will be subjected. Most devices require cord sets rated 125 AC volts at 20 to 30 amperes or 250 AC volts at 20 amps (or greater). Some devices may require a higher or lower rating. Refer to the Owner's manual of the electrical device for the manufacturer's recommendations. Cord sets that are too small in diameter or too long will overheat, become damaged and may cause property damage and/or electrical shock.
- The generator engine consumes oxygen and gives off DEADLY carbon monoxide gas through its exhaust system. This dangerous gas, if breathed in

sufficient concentrations, can cause unconsciousness or even death. Operate this equipment outdoors only, in well ventilated areas where exhaust gases cannot accumulate and endanger people or animals.



WARNING:



The engine exhaust from this product contains chemicals known to the State of California to cause cancer, birth defects, or other reproductive harm.

- Gasoline is extremely FLAMMABLE and its vapors are EXPLOSIVE. Comply with all laws regulating the storage and handling of gasoline. DO NOT permit smoking, open flames, sparks or heat in the vicinity while handling gasoline. Avoid spilling gasoline on a hot engine. DO NOT fill fuel tank while engine is running or hot. Clean off any spilled gasoline before starting engine.
- DO NOT fill fuel tank completely full. Allow room at top of tank for fuel expansion or fuel may expand and overflow onto a hot engine.
- Drain all gasoline from tank before transporting your generator inside your car or other vehicle.
- DO NOT store the generator with fuel in tank where gasoline vapors might reach an open flame, spark, or pilot light, as on a furnace, water heater, dryer, etc. FIRE or an EXPLOSION might result.
- DO NOT insert any object or tool through cooling air slots or openings of the engine or generator, even if the engine is not running. Damage to the unit or personal injury may result.
- DO NOT attempt to change the engine governed speed.. Factory settings are correct when you receive the unit. Excessively high engine speeds may result in injury or damage to equipment.
- DO NOT use the unit if it has been damaged. Repair or replace all damaged or defective components before you run the unit.
- DO NOT permit children to operate or service the generator.
- Read your Owner's Manual carefully. Only persons who are familiar with these safety rules and have been properly instructed in the use of this product should be permitted to use the product.



LOOK FOR THIS SYMBOL TO POINT OUT IMPORTANT SAFETY PRECAUTIONS. IT MEANS "ATTENTION!!! BECOME ALERT!!! YOUR SAFETY IS INVOLVED."

CONGRATULATIONS on your purchase of a Sears Craftsman Generator. It has been designed, engineered and manufactured to give you the best possible dependability and performance.

Should you experience any problem you cannot easily remedy, please contact your nearest Sears Service Center/Department or call the 1-800 number listed in this manual. We have competent, well-trained technicians and the proper tools to service or repair this unit.

Please read and retain this manual. The instructions will enable you to assemble and maintain your generator properly. Always observe the "SAFETY RULES."

MODEL NUMBER	580.327270
SERIAL NUMBER	_____
DATE OF PURCHASE	_____

THE MODEL AND SERIAL NUMBERS WILL BE FOUND ON A DECAL ATTACHED TO THE GENERATOR STATOR CAN.
YOU SHOULD RECORD BOTH SERIAL NUMBER AND DATE OF PURCHASE AND KEEP IN A SAFE PLACE FOR FUTURE REFERENCE.

MAINTENANCE AGREEMENT

A Sears Maintenance Agreement is available on this product. Contact your nearest Sears store for details.

CUSTOMER RESPONSIBILITIES

- Read and observe the safety rules.
- Follow regular schedule in maintaining, caring for and using your generator.
- Follow the instructions under "Maintenance" and "Storage" sections of this Owner's Manual.

FULL TWO YEAR WARRANTY

For two years from the date of purchase, Sears will repair any defect in material or workmanship in this generator at no charge.

If the generator is used for commercial or rental purposes, this warranty applies for only ninety days from the date of purchase:

Warranty service is available by returning the generator to the nearest SEARS SERVICE CENTER/DEPARTMENT throughout the United States.

This warranty gives you specific legal rights and you may also have other rights, which vary from state to state.

SEARS, ROEBUCK AND CO., Department 817 WA, Hoffman Estates, IL 60179

PRODUCT SPECIFICATIONS

Generator Specifications

RATED MAXIMUM POWER	2500 Watts (2.5 kW)
RATED VOLTAGE	120 Volts a-c
RATED MAXIMUM LOAD CURRENT	20.8 a-c amperes
RATED FREQUENCY	60 Hz at 3600 rpm
PHASE	Single Phase

Engine Specifications

RATED HORSEPOWER	5 at 3600 rpm
DISPLACEMENT	10.49 cu. in. (172cc)
SPARK PLUG: Type:	Champion RJ-8C or or equivalent
Set Gap to:	0.030 inch (0.76mm)
GASOLINE CAPACITY	3 U.S. quarts
OIL (1-1/4 U.S. pints)	SAE 30 oil

In the State of California a spark arrester is required by law (Section 4442 of the California Public Resources Code). Other states may have similar laws. Federal laws apply on federal lands.

NOTE: If you equip your generator with a spark arrester muffler, the spark arrester must be maintained in effective working order by the owner/operator.

You can order a spark arrester muffler through your Sears Service Center.

TABLE OF CONTENTS

SAFETY RULES	INSIDE COVER	SERVICE RECOMMENDATIONS.....	10
MAINTENANCE AGREEMENT	1	STORAGE	11
PRODUCT SPECIFICATIONS	1	TROUBLESHOOTING POINTS	12
WARRANTY	1	WIRING DIAGRAM.....	13
OPERATION	3-6	REPAIR PARTS.....	14-20
MAINTENANCE	7-8	EMISSIONS WARRANTY	21-22
SERVICE AND ADJUSTMENTS	9-10	PARTS ORDERING.....	BACK COVER

- A -

Air Cleaner	7, 8
Assembly	4

- B -

Before Starting	4
-----------------------	---

- C -

Carburetor	9
Circuit Breakers	5,6
Cord Sets	5
Customer Responsibilities ...	1

- E -

Engine	
Carburetor adjustment	9
Oil level	7
Speed	9
Electrical Loads	5

- G -

Gasoline	5
Grounding Wing Screw	4

- L -

Lubrication	5,7
-------------------	-----

- M -

Maintenance	
Agreement	1
Cleaning generator	7
Engine maintenance	7
General Recommendations	7
Generator Maintenance	7

- O -

Oil Level	5, 7
Operation	3-6
Overloading	6

- P -

Parts, repair	12-20
---------------------	-------

- S -

Safety Rules	inside cover
Service and Adjustments	
Carburetor	9
Engine Speed	9
Service Recommendations ...	9
Specifications	1
Starting Engine	5
Stopping Engine	6
Storage	9

- T -

Troubleshooting	10
-----------------------	----

- W -

Warranty	
Parts	1
Emission Control	18-19
Wattage Reference Guide ...	6
Wiring Diagram	11

OPERATION

KNOW YOUR GENERATOR

READ THIS OWNER'S MANUAL AND SAFETY RULES BEFORE OPERATING YOUR GENERATOR. Compare the illustrations with your generator, to familiarize yourself with the locations of various controls and adjustments. Save this manual for future reference.

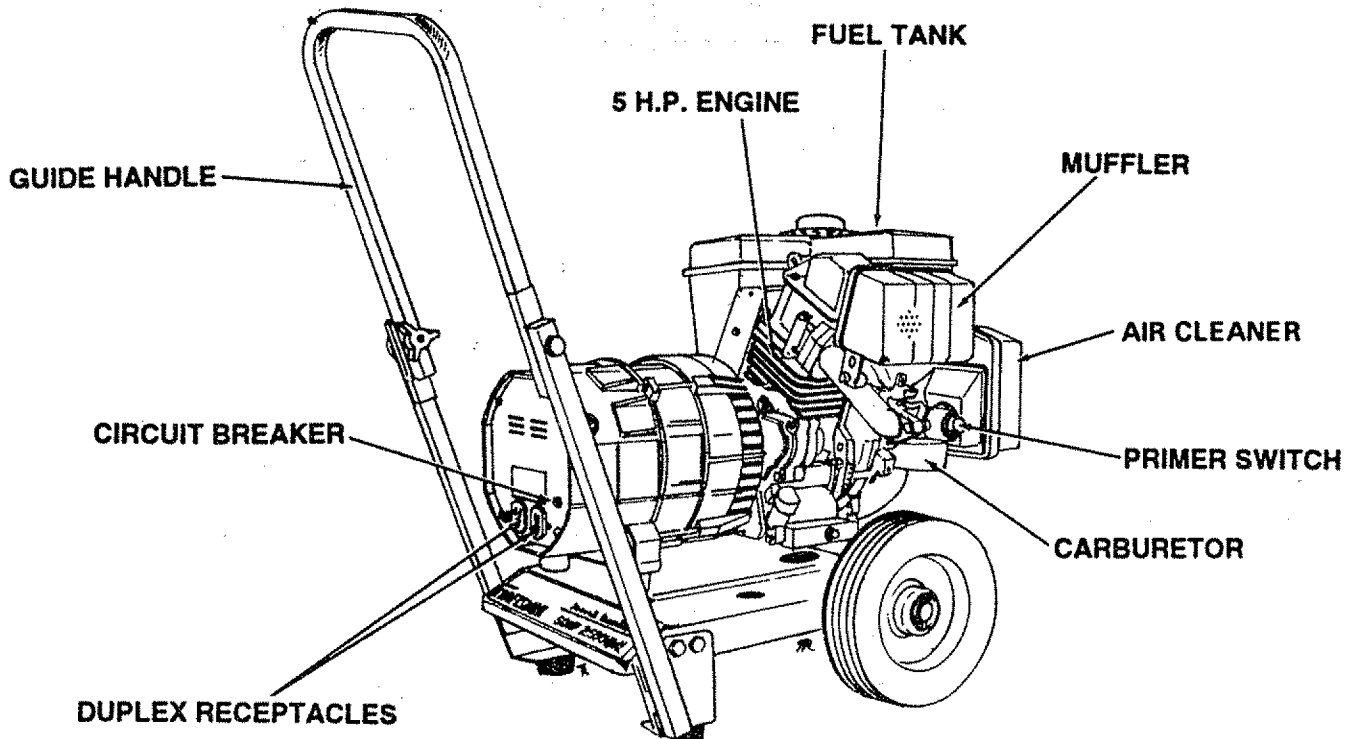

120 VOLTS "DUPLEX" RECEPTACLES — May be used to supply electrical power for the operation of 120 volts at 20 amps a-c, single phase, 60 Hz, a-c electrical lighting, appliance, tool and motor loads.

RECOIL STARTER — Used for starting the engine manually.

FUEL TANK — Tank holds three U.S. quarts of unleaded gasoline.

20-AMP A-C CIRCUIT BREAKER — Protects the generator against electrical overload. Breaker is "push to reset" type.

AIR CLEANER — Filters intake air as it is drawn through the engine.

5 H.P. ENGINE — Provides the power needed to generate 2400 watts of AC output.

OPERATION

Your a-c generator was completely assembled at the factory. It is ready for use after it has been properly serviced with the recommended lubricating oil and fuel.

IF YOU HAVE ANY PROBLEMS WITH THE ASSEMBLY OF YOUR GENERATOR, PLEASE CALL THE GENERATOR HELPLINE AT 1-800-222-3136.

IMPORTANT: ANY ATTEMPT TO RUN THE ENGINE BEFORE IT HAS BEEN SERVICED WITH THE RECOMMENDED OIL WILL RESULT IN AN ENGINE FAILURE.

TO REMOVE GENERATOR FROM CARTON

- Set the carton on a flat rigid surface with "THIS SIDE UP" arrows pointing upward.
- Carefully open the top flaps of shipping carton.
- Cut down corners at one end of shipping carton and lay that side of carton down flat.
- Remove packing material, carton fillers, etc.
- Remove generator from shipping carton.

TO ADJUST GUIDE HANDLE

Your generator is equipped with a wheel kit for easy maneuvering. After you remove the generator from the carton you complete the following tasks to ready to generator for use:

- Loosen knobs of the guide handle as shown in Fig. 1.
- Raise the guide handle as also shown in Fig. 1 and tighten the knobs to hold the handle in place.

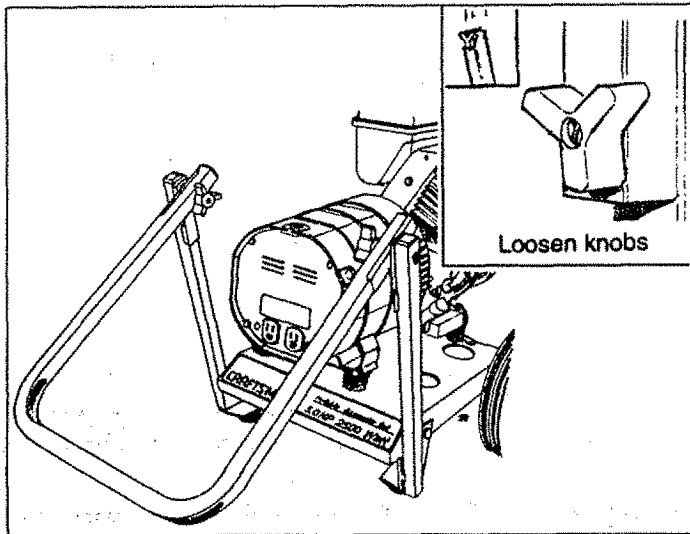

FIG. 1

GROUNDING THE GENERATOR.

The National Electrical Code requires that the frame and external electrically conductive parts of this generator be properly connected to an approved earth ground. Local electrical codes may also require proper grounding of the unit. For that purpose, a GROUNDING LUG is provided on the control panel (Fig. 2). Generally, connecting a No. 12 AWG (American Wire Gauge) stranded copper wire to

the grounding lug and to an earth-driven copper or brass grounding rod (electrode) provides adequate protection against electrical shock (Fig. 2). However, local codes may vary widely. Consult with a local electrician for grounding requirements in your area.

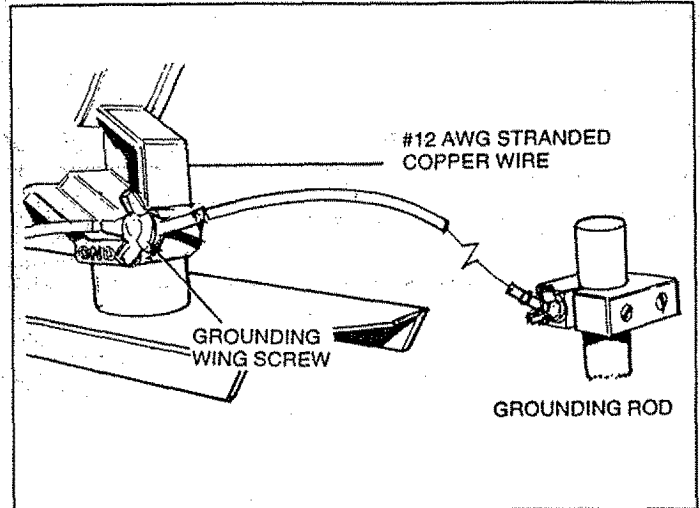

FIG. 2

Proper grounding of generator will help prevent electrical shock in the event of a ground fault condition in the generator or in connected electrical devices. Proper grounding also helps dissipate static electricity, which often builds up in ungrounded devices.

IF YOU HAVE ANY PROBLEMS OPERATING YOUR GENERATOR, PLEASE CALL THE GENERATOR HELPLINE AT 1-800-222-3136.

BEFORE STARTING ENGINE

Add Oil:

Place generator on a level surface and remove oil fill plug. Fill with SAE 30 detergent oil to point of overflowing for oil fill plug (Fig. 3). POUR SLOWLY. DO NOT OVERFILL. Oil capacity of engine is 21 ounces (.62 Liters or 1-1/4 U.S. pints).

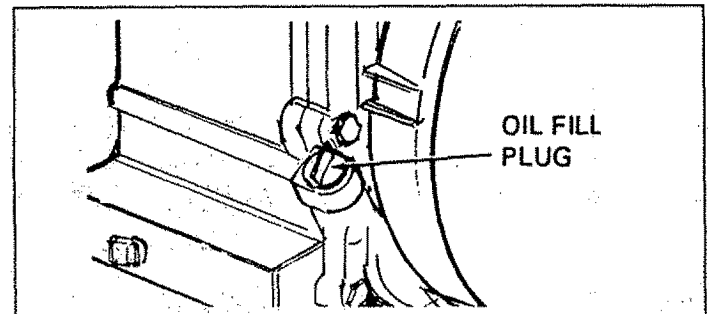

FIG. 3

- When oil sump is full, install and tighten oil fill plug. Use no special additives with recommended oils.

OPERATION

NOTE: Use of multi-viscosity oils above 40°F (4°C) will result in high oil consumption and possible engine damage. Use 5W-30 when operating the generator in weather below 32°F.

NOTE: When adding oil to the engine crankcase in the future, use only high quality detergent oil rated with API service classification SF, SG, or SH, rated SAE 30 weight. Select the oil's viscosity grade according to your expected operating temperature.

Although multi-viscosity oils (5W30) improve starting in cold weather, these multi-viscosity oils will result in in-

colder	32°	warmer
5W30		SAE30

creased oil consumption when used above 32°F. Check your engine oil level more frequently to avoid possible damage from running low on oil. Oil sump capacity is 21 ounces (.62 Liters or 1-1/4 U.S. pints).

Add Gasoline:

- Fill fuel tank with clean, fresh, UNLEADED gasoline. Leaded regular grade gasoline may also be used. DO NOT USE PREMIUM GASOLINE. DO NOT MIX OIL WITH GASOLINE. BE CAREFUL NOT TO OVERFILL FUEL TANK. Allow about 1/4-inch of tank space for expansion.

IMPORTANT: EXPERIENCE INDICATES THAT ALCOHOL-BLENDED FUELS (CALLED GASOHOL) CAN ATTRACT MOISTURE WHICH LEADS TO SEPARATION AND FORMATION OF ACIDS DURING STORAGE. ACIDIC GAS CAN DAMAGE THE FUEL SYSTEM OF AN ENGINE WHILE IN STORAGE. TO AVOID ENGINE PROBLEMS WHEN USING GASOHOL, EMPTY THE FUEL SYSTEM BEFORE STORAGE PERIODS OF 30 DAYS OR LONGER. DRAIN THE GAS TANK, START THE ENGINE AND LET IT RUN UNTIL THE FUEL LINES AND CARBURETOR ARE EMPTY. USE FRESH FUEL NEXT SEASON. SEE STORAGE INSTRUCTIONS FOR ADDITIONAL INFORMATION. NEVER USE ENGINE OR CARBURETOR CLEANER PRODUCTS IN THE FUEL TANK OR PERMANENT DAMAGE MAY OCCUR.

NOTE: DO NOT USE GASOLINE CONTAINING METHANOL (WOOD ALCOHOL). You can use gasolines containing 10% ethanol or grain alcohol. See STORAGE INSTRUCTIONS for more information.

TO START THE ENGINE

Unplug all electrical loads from generator receptacles before starting the engine. Never start or stop engine with electrical devices plugged into panel receptacles and turned on.

- Move engine control lever to "START" position (Fig. 4).
- Press the primer bulb three times. Wait 2 seconds each time you press the primer.

NOTE: The primer may be needed to restart a warm engine after a short shutdown.

- Grasp starter grip and pull slowly until you feel some resistance. Let rope return slowly. Then pull cord out with rapid full arm stroke. Let rope return slowly. Do not let rope "snap back" against starter.

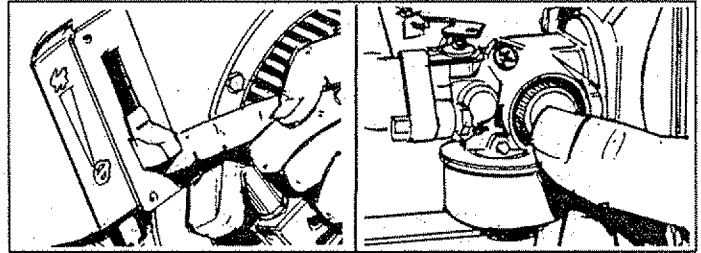

FIG. 4

FIG. 5

120-VOLT CORD SETS

Use only high quality, well-insulated, extension cords with the generator's 120-volt "duplex" type electrical receptacles (Fig. 6). Check the ratings of all extension cords before you use them. Extension cord sets used should be rated 125 volts at 20 a-c amps or greater for most electrical devices. Some devices, however, may not require this type of extension cord. Check the owner's manuals of those devices for the manufacturer's recommendations.

Keep extension cords as short as possible, preferably less than 15 feet long to prevent voltage drop and possible overheating of wires.

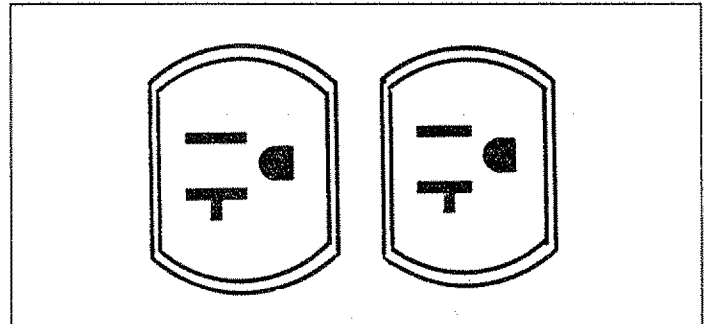

FIG. 6

CONNECTING ELECTRICAL LOADS

- Use this generator to operate 120 volt, single phase, 60 Hz, a-c lighting, appliance, tool and motor loads.
- DO NOT connect 240 volts to 120 volts duplex outlets.
- DO NOT connect any 3-phase loads to panel receptacles.
- DO NOT connect any 50 Hz loads to the generator.
- Add up rated watts of all lights, tool, appliance and motor loads you are powering at one time. This total should NOT be greater than (a) generator's rated wattage capacity, or (b) circuit breaker rating of the receptacle supplying power. See "Don't Overload the Generator" on Page 6.

OPERATION

STOPPING THE ENGINE

- Unplug all electrical loads from generator panel receptacles. Never start or stop engine with electrical devices plugged in and turned on.
- Let engine run at no-load for several minutes to stabilize the internal temperatures of engine and generator.
- Move stop lever to "OFF" position.

DON'T OVERLOAD THE GENERATOR

This generator is equipped with one 20-amp circuit breaker. The duplex receptacle is protected against electrical overload with the 20-amp breaker. Overloading a generator in excess of its rated wattage capacity can result in damage to the generator and to connected electrical devices. Observe the following, to prevent overloading the unit:

- Add up the total wattage of all electrical devices to be connected at one time. This total should NOT be greater than the generator's wattage capacity.
- The rated wattage of lights can be taken from light bulbs. The rated wattage of tools, appliances and motors can usually be found on a data plate or decal affixed to the device.

- If the appliance, tool or motor does not give wattage, multiply 120 volts times ampere rating to determine watts (volts x amps =watts).
- Some electric motors, such as induction types, require about two and a half times more watts of power for starting than for running. This surge of power lasts only a few seconds when starting such motors. Make sure you allow for this high starting wattage when selecting electrical devices to connect to your generator. First, figure the watts needed to start the largest motor. Add to that figure the running watts of all other connected loads.
- The GUIDE below is provided to assist you in determining how many items your generator can operate at one time.

WATTAGE REFERENCE GUIDE

	RUNNING WATTS			RUNNING WATTS
*Air Conditioner (12,000 Btu)	1700		*Jet Pump	700
Battery Charger (20 amp).....	500		Lawn Mower.....	700
Belt Sander (3").....	1000		Light Bulb.....	700
Chain Saw.....	1200		Microwave Oven	700
Circular Saw (6-1/2")	800 to 1000		*Milk Cooler.....	1100
Coffee Maker.....	1000		Oil Burner on Furnace.....	300
*Compressor (1 HP)	2000		Oil Fired Space Heater (140,000 Btu).....	400
*Compressor (3/4 HP)	1800		Oil Fired Space Heater (85,000 Btu).....	225
*Compressor (1/2 HP)	1400		Oil Fired Space Heater (30,000 Btu).....	150
Curling Iron.....	700		*Paint Sprayer, Airless (1/3 HP).....	600
*Deep Freeze	500		Paint Sprayer, Airless (handheld)	150
Disc Sander (9")	1200		Radio.....	50 to 200
Edge Trimmer.....	500		*Refrigerator.....	600
Electric Nail Gun	1200		Slow Cooker.....	200
Electric Range (one element).....	1500		*Submersible Pump (1-1/2 HP).....	2800
Electric Skillet.....	1250		*Submersible Pump (1 HP).....	2000
*Furnace Fan (1/3 HP)	1200		*Submersible Pump (1/2 HP).....	1500
Hair Dryer	1200		Sump Pump	600
Hand Drill (1").....	1100		*Table Saw (10")	1750 to 2000
Hand Drill (1/2").....	750 to 1000		Television.....	200 to 500
Hand Drill (3/8").....	500		Weed Trimmer.....	500
Hand Drill (1/4").....	250			
Hedge Trimmer	450			

* Allow 2-1/2 times the listed watts for starting these devices.

MAINTENANCE

GENERAL RECOMMENDATIONS

The Owner/Operator is responsible for making sure that all periodic maintenance tasks are completed on a timely basis; that all discrepancies are corrected; and that the unit is kept clean and properly stored. Never operate a damaged or defective generator.

GENERATOR MAINTENANCE

Generator maintenance consists of keeping the unit clean and dry. Operate and store the unit in a clean dry environment where it will not be exposed to excessive dust, dirt, moisture or any corrosive vapors. Cooling air slots in the generator must not become clogged with snow, leaves or any other foreign material.

Check the cleanliness of the generator frequently and clean when dust, dirt, oil, moisture or other foreign substances are visible on its exterior surface.

NOTE: We DO NOT recommend using a garden hose to clean the generator. Water can enter the engine fuel system and cause problems. In addition, if water enters the generator through cooling air slots, some of the water will be retained in voids and cracks of the rotor and stator winding insulation. Water and dirt build-up on the generator internal windings will eventually decrease the insulation resistance of these windings.

TO CLEAN THE GENERATOR:

- Use a damp cloth to wipe exterior surfaces clean.
- Use a soft, bristle brush to loosen caked on dirt, oil, etc.
- A vacuum cleaner may be used to pick up loose dirt and debris.
- Low pressure air (not to exceed 25 psi) may be used to blow away dirt. Inspect cooling air slots and opening on the generator. These openings must be dirt clean and unobstructed.

CAUTION: NEVER INSERT ANY OBJECT OR TOOL THROUGH THE AIR COOLING SLOTS, EVEN IF THE ENGINE IS NOT RUNNING. DAMAGE TO THE UNIT OR PERSONAL INJURY MAY RESULT.

ENGINE MAINTENANCE

CHECKING OIL LEVEL

See OPERATION section on Page 4 for information on checking oil level. Oil level should be checked before each use or at least every five hours of operation. Keep oil level maintained.

CHANGING OIL

Change oil after first 2 hours of operation. Change oil every 50 hours thereafter. If you are using your generator under dirty or dusty conditions, or in extremely hot weather, change oil more often.

CAUTION: DISCONNECT SPARK PLUG WIRE FROM SPARK PLUG AND KEEP IT AWAY FROM SPARK PLUG. DO THIS EVERY TIME YOU PERFORM ANY MAINTENANCE ON THE ENGINE OR THE GENERATOR.

Change oil while engine is still warm from running, see follows:

- Clean area around oil drain plug, remove plug (Fig. 7) and drain oil completely into a suitable container. When oil has drained, install and tighten oil drain plug.

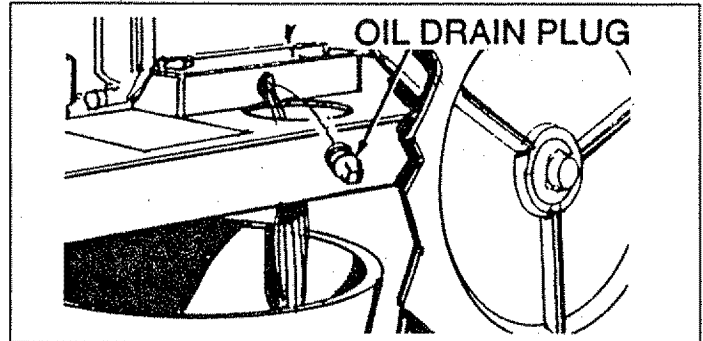

FIG. 7

- Remove oil fill plug and insert a clean fill funnel into plug opening. Fill engine crankcase with recommended oil until oil level is at point of overflowing. About 21 ounces is required. POUR SLOWLY.
- When engine crankcase is filled to proper level. Install and tighten oil fill plug.

SERVICE AIR CLEANER

Your engine will not run properly and may be damaged if you run it using a dirty air cleaner.

Clean or replace the air cleaner paper filter (Fig. 8) once every 100 hours of operation or once a year, whichever comes first. Clean or replace more often if operating under dusty or dirty conditions.

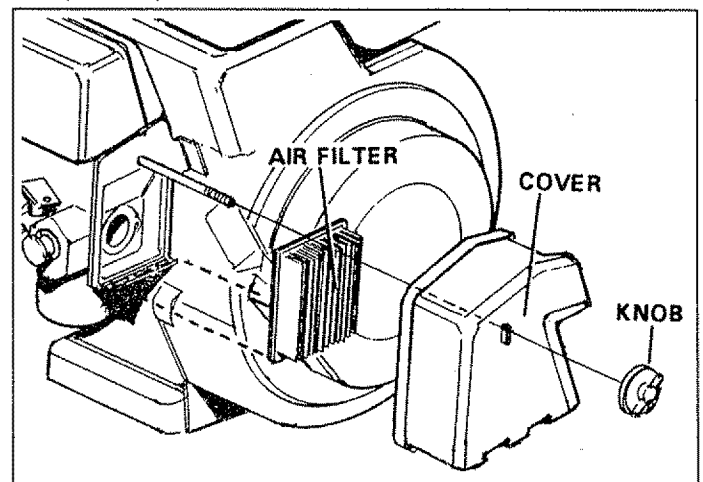

FIG. 8

CAUTION: NEVER RUN THIS UNIT WITHOUT THE COMPLETE AIR CLEANER SYSTEM INSTALLED ON THE ENGINE. THIS COULD RESULT IN PREMATURE WEAR TO THE ENGINE.

MAINTENANCE

To clean or replace air cleaner:

- Remove air cleaner cover; remove paper filter.
- Clean air filter by tapping it gently on a solid surface. If the filter is too dirty, replace it with a new one. Dispose of the oil filter properly.
- Clean air cleaner cover then insert newspaper filter into cover and assemble to the base of the air cleaner.

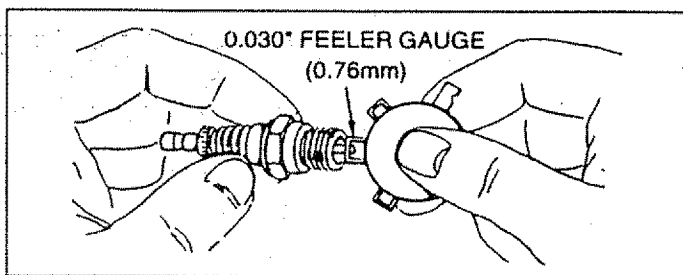

FIG. 9

REPLACE SPARK PLUG

Change the spark plug every 100 hours of operation or once each year, whichever comes first. This will help your engine to start easier and run better. Replace with Champion RC-J8 or equivalent type spark plug. Set spark plug gap (Fig. 9) to 0.030 inch (0.76mm).

SERVICE RECOMMENDATIONS

MAINTENANCE OPERATION	Every 5 Hours or Daily	25 Hours or Every Season	50 Hours or Every Season	100 Hours or Every Season
Check Oil Level	X			
Change Oil			See Note 1	X
Service Air Filter		See Note 2		
Replace or Clean Spark Plug				X
Prepare Unit for Storage	Prepare unit for storage if it is to remain idle for more than 30 days.			

NOTE 1: Change oil and oil filter after first 2 hours of operation and then every 50 hours thereafter. Change sooner when operating under heavy load or in dusty or dirty environment or in high ambient temperature.

NOTE 2: Clean more often when operating the unit under dirty or dusty conditions.

SERVICE AND ADJUSTMENTS

ENGINE SPEED



CAUTION: ENGINE SPEED WAS PROPERLY ADJUSTED AT THE FACTORY AND SHOULD REQUIRE NO ADDITIONAL ADJUSTMENT. DO NOT ATTEMPT TO CHANGE ENGINE SPEED. IF YOU BELIEVE THE ENGINE IS RUNNING TOO FAST OR TOO SLOW, TAKE YOUR GENERATOR TO AUTHORIZED SERVICE CENTER FOR REPAIR AND ADJUSTMENT. CHANGING ENGINE GOVERNED SPEED WILL VOID ENGINE WARRANTY.

Your generator runs at a constant speed. This constant operating speed is maintained by a mechanical, flyweight type, fixed speed governor. DO NOT try to adjust the governed speed setting for the following reasons:

- High engine speeds are dangerous and increase the risk of personal injury or damage to equipment.
- Low engine speeds impose a heavy load on the engine when sufficient engine power is not available and may shorten engine life.

- The generator will supply correct rated AC frequency and voltage only at the proper speed. Some connected electrical devices could be damaged by incorrect frequency and/or voltage.

ADJUSTING THE CARBURETOR

The carburetor of your generator set is preset at the factory. DO NOT TAMPER WITH THE CARBURETOR as this will void the warranty for the emission control system. If your generator is to be used at an altitude above 5,000 feet, consult with a Sears Authorized Service Facility regarding high altitude jetting changes.

STORAGE

The generator should be started at least once every seven days and allowed to run at least 30 minutes. If this cannot be done and you must store the unit for more than 30 days, use the following information as a guide to prepare it for storage.

STORAGE INSTRUCTIONS



WARNING: NEVER STORE ENGINE WITH FUEL IN THE TANK INDOORS OR IN ENCLOSED, POORLY VENTILATED AREAS, WHERE FUMES CAN REACH AN OPEN FLAME SPARK OR PILOT LIGHT AS ON A FURNACE, WATER HEATER, CLOTHES DRYER OR OTHER GAS FURNACE.

ENGINE

- Run engine for about five minutes to warm it.

NOTE: If you did use "gasohol," drain fuel tank, then run engine until engine stops from lack of fuel.



WARNING: DRAIN FUEL INTO APPROVED CONTAINER OUTDOORS, AWAY FROM OPEN FLAME. BE SURE ENGINE IS COOL.

NOTE: Using a fuel additive such as Sears Craftsman® Fuel Stabilizer, or an equivalent, will prevent gum deposits from forming in the generator's fuel system.

- While engine is still warm, drain oil from crankcase. Refill with fresh oil. See BEFORE STARTING ENGINE on Page 5 for oil recommendations.
- Remove spark plug and pour about 1 ounce (30ml) of engine oil into cylinder. Crank slowly to distribute oil.



CAUTION: AVOID SPRAY FROM SPARK PLUG HOLE WHEN CRANKING ENGINE SLOWLY.

- Install spark plug. Do not connect spark plug wire.
- Clean dirt, oil and grease from cylinder, cylinder head, fins, blower housing, rotating screen and muffler area.

GENERATOR

- Clean the generator as outlined on Page 7 ("To Clean the Generator").
- Check that cooling air slots and openings on generator are open and unobstructed.

OTHER STORAGE TIPS

- Do not store gasoline from one season to another.
- Replace your gasoline can if it starts to rust. Rust and/or dirt in your gasoline can cause problems when you use it with this unit.
- Store in clean and dry area.



DANGER: STORAGE COVER IS FLAMMABLE. DO NOT PLACE THE STORAGE COVER OVER A HOT GENERATOR. LET THE UNIT COOL FOR A SUFFICIENT TIME BEFORE PLACING THE COVER ON THE UNIT. IF YOU PLACE THE COVER ON THE UNIT BEFORE GENERATOR IS COOL, THE COVER COULD START ON FIRE.

TROUBLESHOOTING POINTS

PROBLEM	CAUSE	CORRECTION
Engine is running, but no AC output is available.	<ol style="list-style-type: none"> 1. One of the circuit breakers is open. 2. Fault in generator. 3. Poor connection or defective cord set. 4. Connected device is bad. 	<ol style="list-style-type: none"> 1. Reset circuit breaker. 2. Contact Sears Service Department. 3. Check and repair. 4. Connect another device that is in good condition.
Engine runs good at no-load but "bogs down" when loads are connected	<ol style="list-style-type: none"> 1. Short circuit in a connected load. 2. Engine speed is too slow. 3. Generator is overloaded. 4. Shorted generator circuit. 	<ol style="list-style-type: none"> 1. Disconnect shorted electrical load. 2. Contact Sears Service Department. 3. See "Don't Overload the Generator on Page 10." 4. Contact Sears Service Department.
Engine will not start; or starts and runs rough.	<ol style="list-style-type: none"> 1. Run/Stop Switch set to STOP. 2. Dirty air cleaner 3. Out of gasoline. 4. Stale gasoline. 5. Spark plug wire not connected to spark plug. 6. Bad spark plug. 7. Water in gasoline. 8. Overchoking. 9. Excessively rich fuel mixture. 10. Intake valve stuck open or closed. 11. Engine has lost compression. 12. Intake valve stuck open or closed. 13. Engine compression lost. 14. Failed battery. 	<ol style="list-style-type: none"> 1. Set switch to RUN. 2. Clean or replace air cleaner. 3. Fill fuel tank. 4. Drain gas tank; fill with fresh fuel. 5. Connect wire to spark plug. 6. Replace spark plug. 7. Drain gas tank; fill with fresh fuel. 8. Open choke fully and crank engine. 9. Contact Sears Service Department. 10. Contact Sears Service Department. 11. Contact Sears Service Department. 12. Contact Sears Service Department. 13. Contact Sears Service Department. 14. Replace battery.
Engine shuts down during operation	<ol style="list-style-type: none"> 1. Out of gasoline. 2. Low oil level. 	<ol style="list-style-type: none"> 1. Fill fuel tank. 2. Fill crankcase to proper level.
Engine lacks power.	<ol style="list-style-type: none"> 1. Load is too high. 2. Dirty air filter. 	<ol style="list-style-type: none"> 1. See "Don't Overload the Generator" on Page 10. 2. Replace air filter.
Engine "hunts" or falters.	Carburetor is running too rich or too lean.	Contact Sears Service Department.

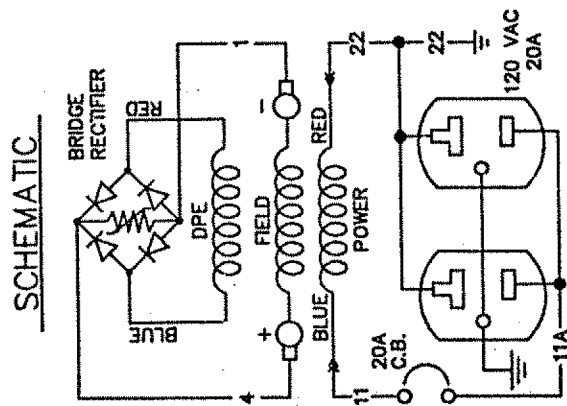
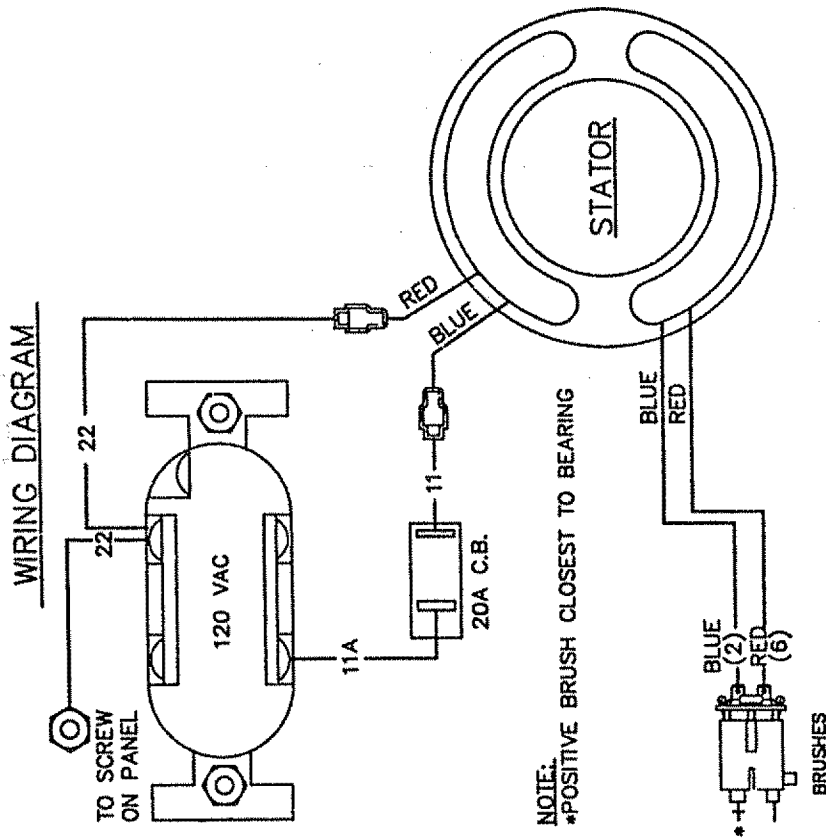

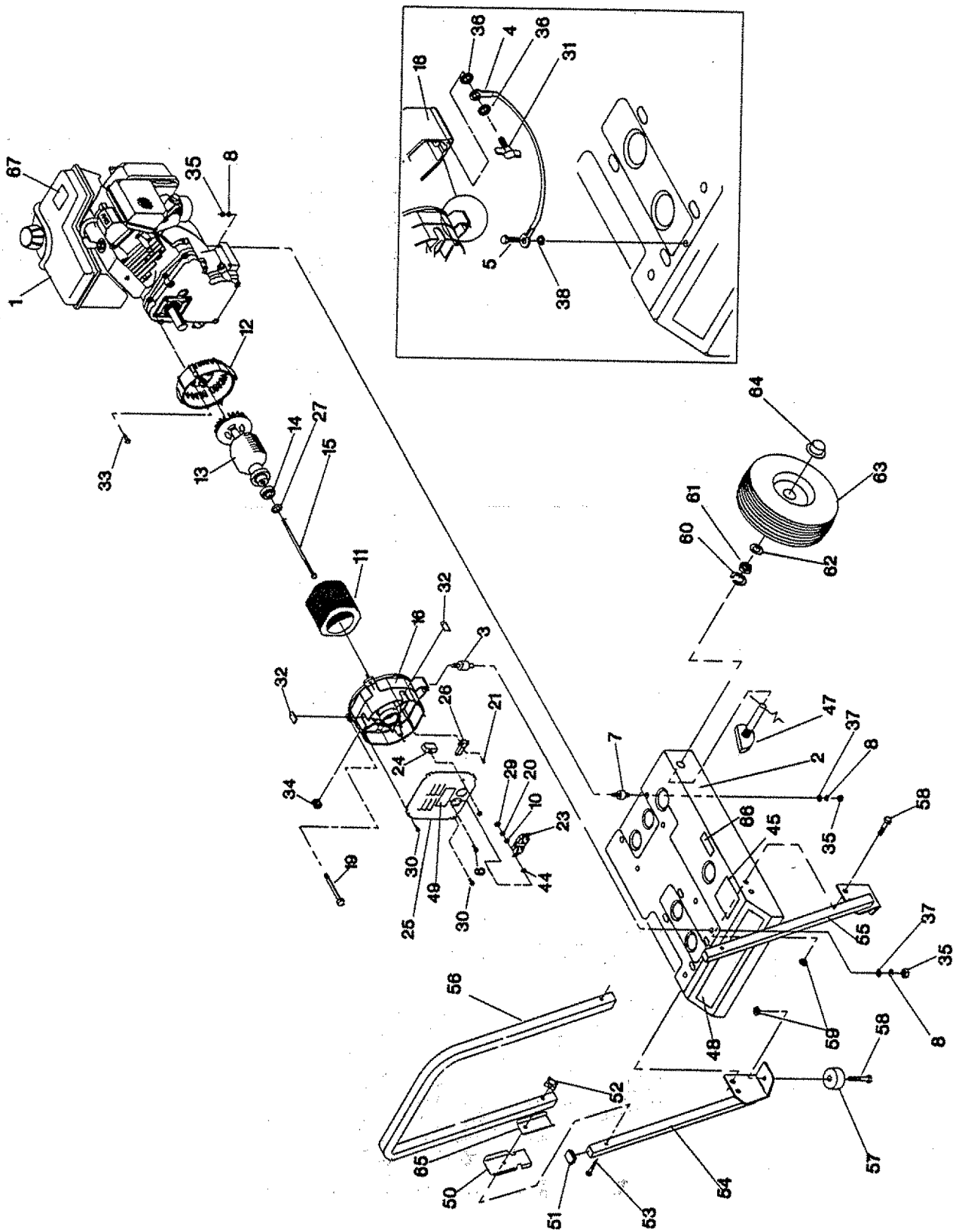

CRAFTSMAN 2500 WATT A-C GENERATOR 580. 327270

REPAIR PARTS

ITEM	PART NO.	DESCRIPTION	ITEM	PART NO.	DESCRIPTION
1	99369	ENGINE-5HP TECUMSEH (1 REQ.)	33	86307	CAPSCREW, HEX HD (4 REQ.) 5/16"-24 x 3/4" SEMS
2	95902	BASE, MOUNTING (1 REQ.)	34	67022	GROMMET, BEARING CARRIER (1 REQ.)
3	85652	VIBRATION MOUNT-ALT. (2 REQ.)	35	45771	M8-1.25 HEX NUT (6 REQ.)
4	143-53621	GROUND WIRE (1 REQ.)	36	26850	WASHER, SHAKE-PROOF M6-1/4 (2 REQ.)
5	86292	CAPSCREW, SELF DRILLER #10 (1 REQ.)	37	22145	FLAT WASHER-M8 (4 REQ.)
6	75475	SCREW, PAN HD. MACH. M4-0.7 x 10 (2 REQ.)	38	22769	WASHER, SHAKE PROOF #10 (1 REQ.)
7	85651	MOUNT, VIBRATION-ENGINE (2 REQ.)	45	93639	DECAL, DANGER-ENGLISH (1 REQ.)
8	22129	LOCK WASHER-M8 (6 REQ.)	47	93728	AXLE, WHEEL (2 REQ.)
10	38150	WASHER, FLAT-#8 (2 REQ.)	48	99377	DECAL, LOGO (1 REQ.)
11	91824	STATOR ASSEMBLY (1 REQ.)	49	98247	DECAL, CONTROL PANEL (1 REQ.)
12	66365-F	HOUSING, ENGINE ADAPTOR (1 REQ.)	50	97082	POSITIONER, HANDLE (2 REQ.)
13	91820	ROTOR ASSEMBLY (1 REQ.)	51	81895	CAP PLUG, 3/4" SQUARE (4 REQ.)
14	65791	BEARING, BALL (1 REQ.)	52	97178	KNOB, HANDLE (2 REQ.)
15	24420	BOLT, ROTOR-5/16"-24 x 6.25 (1 REQ.)	53	97912	BOLT, CARRIAGE-1/4-20" x 2-1/4" (2 REQ.)
16	66825B	CARRIER, REAR BEARING (1 REQ.)	54	98956B	LEG & FOOT SUPPORT ASSEM. LEFT SIDE (1 REQ.)
19	86308D	BOLT, STATOR M6-1.00 x 85MM (4 REQ.)	55	98956A	LEG & FOOT SUPPORT ASSEM. RIGHT SIDE (1 REQ.)
20	22264	LOCK WASHER-NO.8 (2 REQ.)	56	98955	HANDLE (1 REQ.)
21	66849	SCREW(TAPTITE)-M5-0.80 x 16mm (2 REQ.)	57	87841	VIBRATION MOUNT-LEG (2 REQ.)
23	68759	RECEPTACLE-120VOLTS AC, 20A (1 REQ.)	58	39253	SCREW, HEX HD. CAPSC. M8-1.25 x 20 LONG (6 REQ.)
24	77247	BREAKER, CIRCUIT-20A (1 REQ.)	59	52858	NUT, FLANGE-M8-1.25 (6 REQ.)
25	72092	PANEL, RECEPTACLE (1 REQ.)	60	22246	LOCKWASHER-5/8" (2 REQ.)
26	91825	BRUSH & BRIDGE RECTIFIER (1 REQ.)	61	25391	NUT, JAM-5/8"-18 (2 REQ.)
27	67451	FLAT WASHER-[SPECIAL] (1 REQ.)	62	49808	WASHER, FLAT-M12 (2 REQ.)
29	51715	NUT, HEX-M4-0.7 (2 REQ.)	63	91094	WHEEL, 8" DIA. (2 REQ.)
30	74908	SCREW(TAPTITE)-M5-0.80 x 10mm (4 REQ.)	64	75402	PUSH NUT-1/2" DIA. (2 REQ.)
31	86494	SCREW, M6-1.0 x 16 WING (1 REQ.)	65	99368	PLATE, ANTI SCRATCH AND WEAR (2 REQ.)
32	84242	GROMMET RBC (2 REQ.)	66	96049	DECAL, 1-800 NUMBER (1 REQ.)
			67	99541	DECAL, START INSTRUCTIONS (1 REQ.)

CRAFTSMAN 2500 WATT A-C GENERATOR 580.327270
CRAFTSMAN 4-CYCLE ENGINE 143.965011

REPAIR PARTS

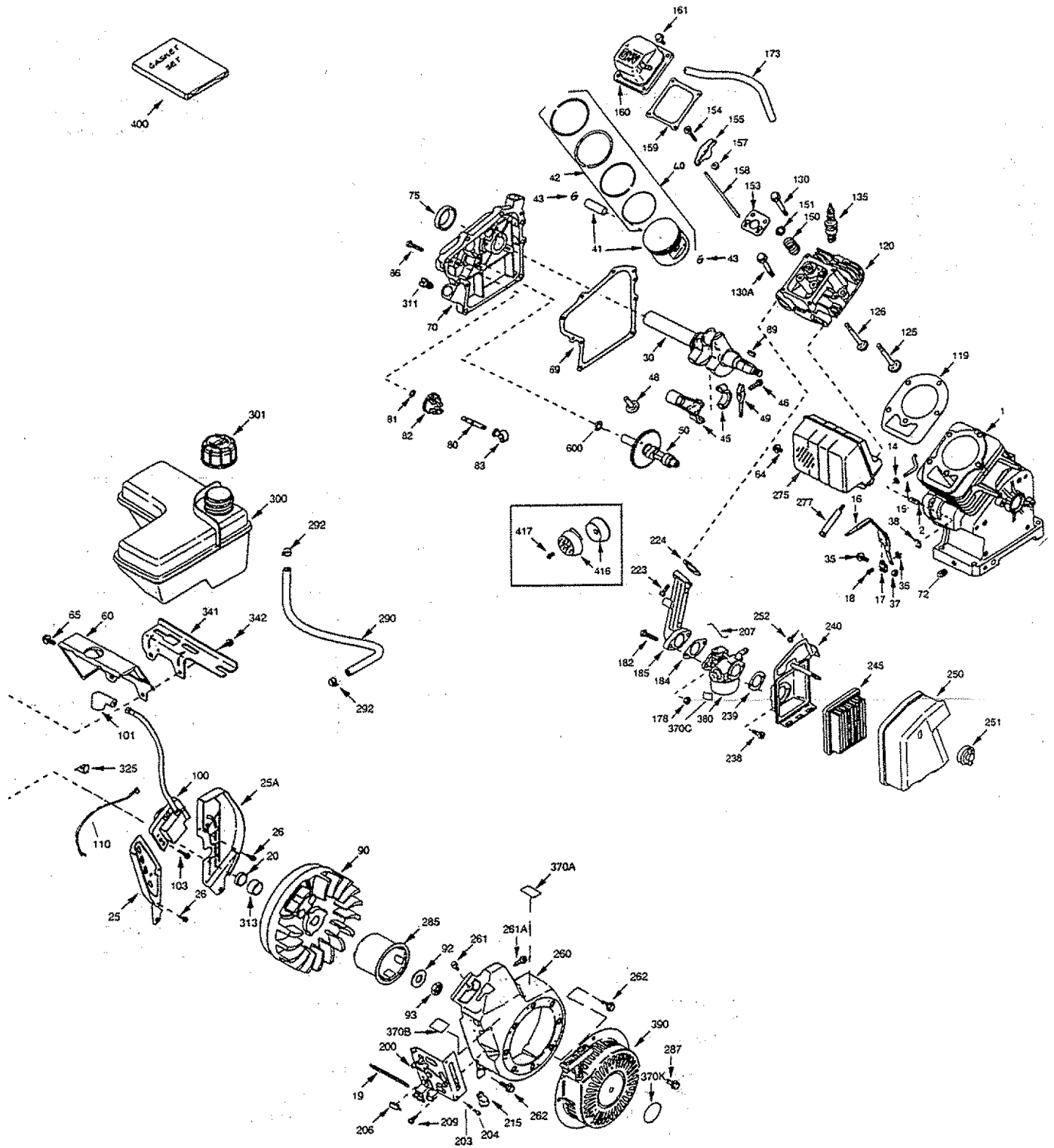

CRAFTSMAN 2500 WATT A-C GENERATOR 580.327270
CRAFTSMAN 4-CYCLE ENGINE 143.965015

REPAIR PARTS

ITEM	PART NO.	DESCRIPTION	ITEM	PART NO.	DESCRIPTION
1	36768	Cylinder (includes 2, 20, 72 & 125) [1 req.]	126	29314B	Std. Intake Valve (1 req.)
2	26727	Dowel Pin (2 req.)	130	29315C	O.S. Intake Valve (1 req.)
14	28277	Washer (1 req.)	650912	650912	5/16-18 x 1-1/2" Screw (7 req.)
15	30589	Governor Rod	130A	650999	5/16-18 x 2-41/64" Screw (1 req.)
16	36618	Governor Lever (1 req.)	136	34645	Spark Plug [RJ-17LM] (1 req.)
17	36700	Governor Lever Clamp (1 req.)	150	31672	Valve Spring (2 req.)
18	650548	No. 8-32 x 5/16" Hex Screw (1 req.)	151	31673	Lower Valve Spring Cap (2 req.)
19	36750	Extension Spring (1 req.)	153	36649	Push Rod Guide (1 req.)
20	32600	Oil Seal (1 req.)	154	650913	Rocker Arm Stud (2 req.)
25	36621	Air Baffle (1 req.)	155	36624A	Rocker Arm (2 req.)
25A	36622	Air Baffle (1 req.)	157	650914	1/4"-28 Nut (2 req.)
26	30200	#10-24 x 9/16" Screw (2 req.)	158	36629	Push Rod (2 req.)
30	34734A	Crankshaft (1 req.)	159	36626	Rocker Arm Cover Gasket (1 req.)
35	29826	Screw, #10-32 x 3/4" (1 req.)	160	36630A	Rocker Arm Cover (1 req.)
36	29918	Lock Washer (1 req.)	161	651008	1/4"-20 x 31/64" Screw (2 req.)
37	29216	Lock Nut, #10-32 (1 req.)	181A	651012	Stud (2 req.)
38	29642	Retaining Ring (1 req.)	173	36675	Breather Tube (1 req.)
40	35544A	Piston Pin & Ring Set (Std.)	178	650852	1/4"-20 Nut (2 req.)
	35545A	Piston, Pin & Ring Set (0.01 O.S.)	182	650451	1/4-20 x 1" Screw (2 req.)
	35546	Piston, Pin & Ring Set (0.02 O.S.)	184	26756	Carburetor Gasket (1 req.)
41	35541	Piston & Pin Assy. (STD.)	185	36631	Intake Pipe (1 req.)
	35542	Piston & Pin Assy. (0.01 O.S.)	200	36747	Control Bracket Assembly (1 req.)
	35543	Piston & Pin Assy. (0.02 O.S.)	203	31342	Compression Spring (1 req.)
42	35547A	Piston Ring Set (STD.)	204	650549	5-40 x 7/16" Screw (1 req.)
	35548A	Piston Ring Set (0.01 O.S.)	206	610973	Terminal Assembly (1 req.)
	35549	Piston Ring Set (0.02 O.S.)	207	36632	Throttle Link (1 req.)
43	20381	Piston Pin Retaining Ring (1 req.)	209	650821	#10-32 x 1/2" Screw (2 req.)
45	32875A	Connecting Rod Assy. (1 req.)	215	36638	Control Knob (1 req.)
46	32610A	Connecting Rod Bolt (1 req.)	223	650451	5/16-18 x 1" Screw (2 req.)
48	35616	Valve Lifter (1 req.)	224	36581	Intake Pipe Gasket (1 req.)
49	36611	Oil Dipper (1 req.)	238	28820	#10-32 x 1/2" Screw (2 req.)
50	36620	Cameshaft (BCR) (1 req.)	239	27272A	Air Cleaner Gasket (1 req.)
60	36623	Blower Housing Ext. (1 req.)	240	36633	Air Cleaner Body (incl. 239) (1 req.)
64	650378	Screw, 1/4"-20 x 5/8" (1 req.)	245	36046	Air Cleaner Filter (1 req.)
65	30200	No. 10-24 x 9/16" Screw (1 req.)	250	36635	Air Cleaner Cover (1 req.)
69	36624	Cylinder Cover Gasket (1 req.)	251	650886	Wing Nut (1 req.)
70	36761	Cylinder Cover Assy. (1 req.)	252	650821	#10-32 x 1/2" Screw (1 req.)
72	27642	Oil Drain Plug (2 req.)	253	36701	Compression Release (1 req.)
75	28460	Oil Seal (1 req.)	254	36702	Compression Release Spring (1 req.)
80	30574A	Governor Shaft (1 req.)	260	36812	Fuel Tank & Blower Housing (1 req.)
81	30590A	Flat Washer (1 req.)	261	651008	1/4-20 x 31/64" Screw (1 req.)
82	30591	Governor Gear (1 req., incl. No. 81)	261A	650821	#10-32 x 1/2" Screw (1 req.)
83	36057	Governor Spool (1 req.)	262	651008	1/4-20 x 31/64" Screw (2 req.)
86	650488	1/4-20 x 1-1/4" Screw (7 req.)	275	36641	Muffler (1 req.)
89	610961	Flywheel Key (1 req.)	277	651009	1/4-20 x 2-9/32" Screw (2 req.)
90	611205	Flywheel (1 req.)	285	369858	Starter Cup (1 req.)
92	650815	Bellefonte Washer (1 req.)	287	0	Rivet (can be purchased locally)
93	650816	Flywheel Nut (1 req.)	290	30705	Fuel Line (1 req.)
100	34443A	Solid State Ignition (1 req.)	292	26460	Fuel Line Clamp (1 req.)
101	610118	Spark Plug Cover (1 req.)	300	36812	Fuel Tank & Blower Housing (1 req.)
102	651007	Solid State Mounting Stud (2 req.)	301	36246	Fuel Cap (1 req.)
103	650814	No. 10-24 x 1" Torx Screw (2 req.)	311	27625	Oil Fill Plug (1 req.)
110	36767	Ground Wire (1 req.)	313	34080	Spacer (1 req.)
111	611207	Low Oil Sensor (1 req.)	325	29443	Wire Clip (1 req.)
111A	611212	Low Oil Indicator Light (1 req.)	341	36644	Fuel Tank Bracket (1 req.)
112	35967	Low Oil Sensor Gasket (1 req.)	370A	36261	Lubrication Decal (1 req.)
113	650950	Torx T-25 #10-24 x 5/8" Screw (4 req.)	370B	33107	Control Decal (1 req.)
119	36738	Cylinder Head Gasket (1 req.)	370C	36260	Primer Decal (1 req.)
120	36739	Cylinder Head (1 req.)	370K	36695	Starter Decal (1 req.)
125	36471	Exhaust Valve [Std., incl. 151] (1 req.)	380	640017	Carburetor [incl. No. 184] (1 req.)
	36472	Exhaust Valve [1/32" OS, incl. 151] (1 req.)	390	590736	Rewind Starter (1 req.)
			400	36716A	Gasket Set (1 req.)
			416	36085	Spark Arresting Screen and Cover [optional] (1 req.)
			417	650760	#8-32 x 3/8" Screw [optional] (1 req.)
			600	651013	Washer (1 req.)

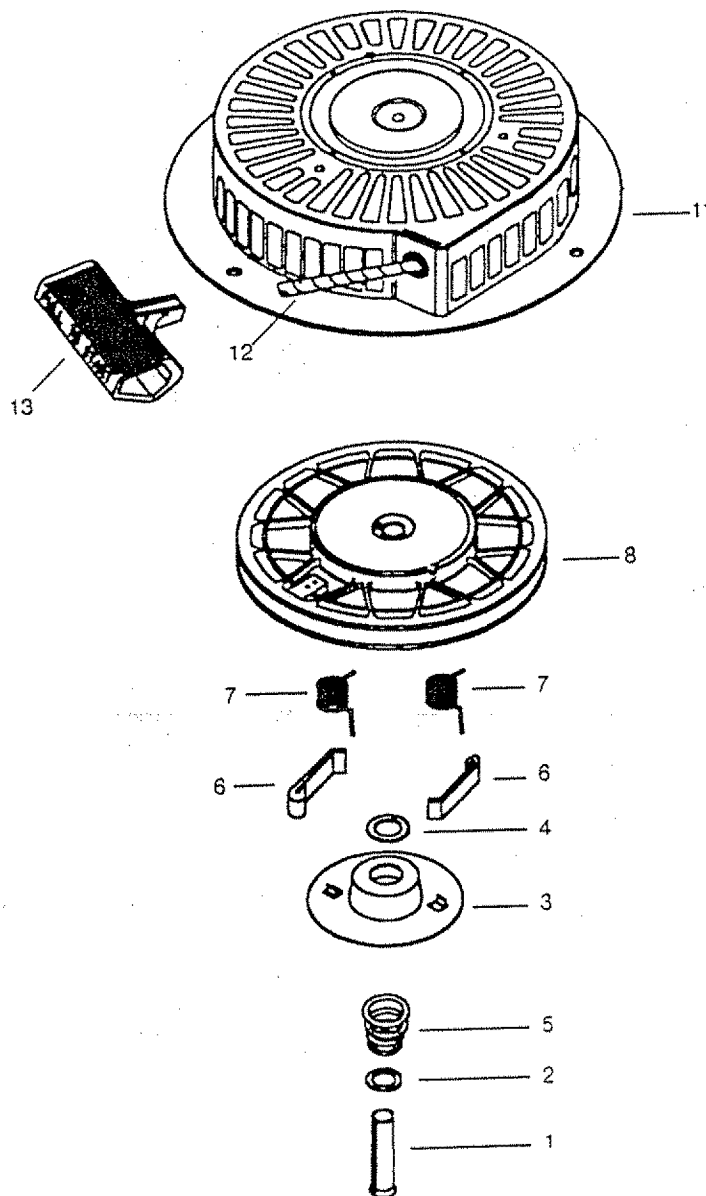

Rewind Starter No. 590736

ITEM	PART NO.	DESCRIPTION
1	590599A	PIN, SPRING [included No. 4] (1 REQ.)
2	590600	WASHER (1 REQ.)
3	590696	RETAINER (1 REQ.)
4	590601	WASHER (1 REQ.)
5	590697	SPRING, BRAKE (1 REQ.)
6	590698	DOG, STARTER (2 REQ.)
7	590699	SPRING, DOG (2 REQ.)
8	590700	PULLEY AND REWIND SPRING ASSEMBLY (1 REQ.)
11	590687	HOUSING ASSEMBLY, STARTER (1 REQ.)
12	590535	ROPE, STARTER (1 REQ.)
13	590701	HANDLE ASSEMBLY, STARTER (1 REQ.)

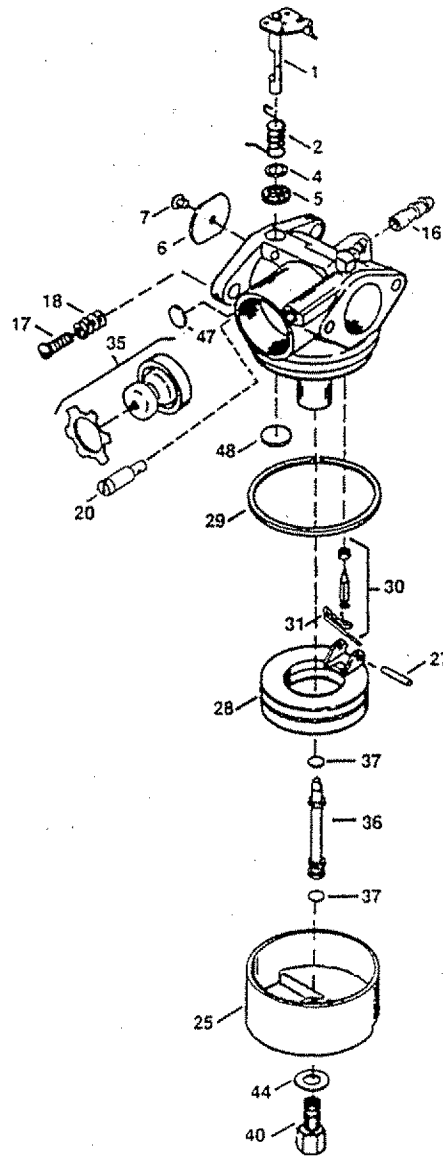

Carburetor No. 640017

ITEM	PART NO.	DESCRIPTION	ITEM	PART NO.	DESCRIPTION
1	631615	Throttle Shaft and Lever Assembly (1 req.)	31	631022	Spring Clip (1 req.)
2	631767	Throttle Return Spring (1 req.)	35	36045	Primer Bulb/retainer Ring (1 req.)
4	631184	Dust Seal Washer (1 req.)	36	640019	Main Nozzle Tube (1 req.)
5	631183	Dust Seal [throttle] (1 req.)	37	632547	"O" Ring, Main Nozzle Tube (2 req.)
6	631036	Throttle Shutter (1 req.)	40	640015	High Speed Bowl Nut (1 req.)
7	650506	Shutter Screw (1 req.)	44	27110	Bowl Nut Washer (1 req.)
16	632164	Fuel Fitting (1 req.)	47	630748	Idle Mixture Well Welch Plug (1 req.)
17	650417	Throttle Crack /Idle Speed Screw	48	631027	Welch Plug, Atmospheric Vent (1 req.)
18	630766	Tension Spring (1 req.)	28	632019	Float (1 req.)
20	640018	Idle Restrictor Screw (1 req.)	29	631028	"O" Ring, Float Bowl-to-body (1 req.)
25	631867	Float Bowl (1 req.)	30	631021	Inlet Needle, Seat & Spring Clip. [incl. No. 31] (1 req.)
27	631024	Shaft, Float (1 req.)			

FOR CALIFORNIA RESIDENTS ONLY WHEN SEEKING SERVICE IN CALIFORNIA
CALIFORNIA EMISSION CONTROL WARRANTY STATEMENT
YOUR WARRANTY RIGHTS AND OBLIGATIONS

The California Air Resources Board and Sears Roebuck and Co., USA (Sears), are pleased to explain the emissions control system warranty on your 1995 and later lawn and garden equipment engine. In California new utility and lawn and garden equipment engines must be designed, built, and equipped to meet the State's stringent anti-smog standards. Sears must warrant the emission control system on your lawn and garden equipment engine for the periods of time listed below provided there has been no abuse, neglect, or improper maintenance of your lawn and garden equipment engine.

Your emission control system includes parts such as the carburetor and the ignition system. Where a warrantable condition exists, Sears will repair your lawn and garden equipment engine at no cost to you. Expenses covered under warranty include diagnosis, parts, and labor.

MANUFACTURER'S WARRANTY COVERAGE

The 1995 and later utility and lawn and garden equipment engines are warranted for two years. If any emission related part on your engine (as listed below) is defective, the part will be repaired or replaced by Sears.

OWNER'S WARRANTY RESPONSIBILITIES

As the lawn and garden equipment engine owner, you are responsible for the performance of the required maintenance listed in your Owner's Manual. Sears recommends that you retain all receipts covering maintenance on your lawn and garden equipment engine, but Sears cannot deny warranty solely for the lack of receipts or for your failure to ensure the performance of all scheduled maintenance.

As the lawn and garden equipment engine owner, you should be aware that Sears may deny you warranty coverage if your lawn and garden equipment engine or a part of it has failed due to abuse, neglect, improper maintenance, unapproved modifications, or the use of parts not made or approved by the original equipment manufacturer.

You are responsible for presenting your lawn and garden equipment engine to a Sears authorized repair center as soon as a problem exists. Warranty repairs should be completed in a reasonable amount of time, not to exceed 30 days.

If you have any questions regarding your warranty rights and responsibilities, you should contact your nearest authorized service center or call Sears at 1-800-473-7247.

WARRANTY COMMENCEMENT DATE

The warranty period begins on the date the lawn and garden equipment engine is delivered to the original, end-use purchaser.

LENGTH OF COVERAGE

Sears warrants to the initial owner and each subsequent purchaser that the engine is free from defects in materials and workmanship which cause the failure of a warranted part for a period of two years.

Free Manuals Download Website

<http://myh66.com>

<http://usermanuals.us>

<http://www.somanuals.com>

<http://www.4manuals.cc>

<http://www.manual-lib.com>

<http://www.404manual.com>

<http://www.luxmanual.com>

<http://aubethermostatmanual.com>

Golf course search by state

<http://golfingnear.com>

Email search by domain

<http://emailbydomain.com>

Auto manuals search

<http://auto.somanuals.com>

TV manuals search

<http://tv.somanuals.com>