

OWNER'S MANUAL

CRAFTSMAN®

**7.5 Horsepower
2700 PSI 3 GPM
High Pressure Washer**

**Model No:
919.762700**

1350psi

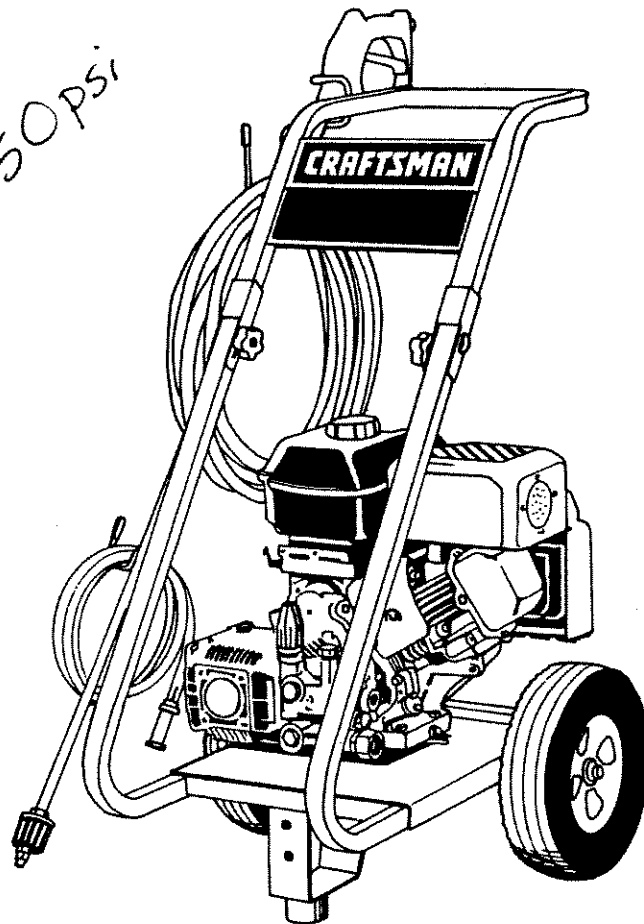

WARNING: Before using this product, read this manual and follow all Safety Rules and Operating Instructions.

**PRESSURE WASHER
CUSTOMER
HELPLINE
1-800-245-5873**

- Safety
- Assembly
- Operation
- Maintenance
- Parts List
- Español

Sears, Roebuck and Co., Hoffman Estates, IL 60179 U.S.A.

TABLE OF CONTENTS

Warranty	2	Storage	14
Safety Guidelines	3-5	Troubleshooting	15
Assembly	5-7	Parts.....	16-30
Operation	7-10	EPA Codes	31-32
Maintenance	11-13	How to Order Parts	Back Cover
Service and Adjustments.....	14	Español	34-52

LIMITED ONE YEAR WARRANTY ON CRAFTSMAN HIGH PRESSURE WASHER

For one year from the date of purchase, when this Craftsman High Pressure Washer is maintained and operated according to the instructions in the owner's manual, Sears will repair, free of charge, any defect in material and workmanship.

If your Craftsman Pressure Washer is used for commercial or rental purposes, this warranty applies only for 90 days from the date of purchase.

LIMITED ONE YEAR WARRANTY ON CRAFTSMAN ENGINE

For one year from the date of purchase, when this Craftsman engine is maintained and operated according to the instructions in the owner's manual, Sears will repair, free of charge, any defect in material and workmanship.

If your Craftsman engine is used for commercial or rental purposes, this warranty applies only for 90 days from the date of purchase. This warranty does not cover: Expendable items such as spark plugs and air filters, which become worn during normal use.

Repairs necessary because of operator abuse or negligence, including damage resulting from no water being supplied to pump or failure to maintain the equipment according to the instructions contained in the owner's manual, are not covered under warranty.

WARRANTY SERVICE IS AVAILABLE BY RETURNING THE HIGH PRESSURE WASHER TO THE NEAREST SEARS SERVICE CENTER/DEPARTMENT THROUGHOUT THE UNITED STATES.

This warranty gives you specific legal rights and you may also have other rights, which vary from state to state.

Sears, Roebuck and Co., D/817 WA, Hoffman Estates, IL 60179

SAFETY GUIDELINES - DEFINITIONS

This manual contains information that is important for you to know and understand. This information relates to protecting **YOUR SAFETY** and **PREVENTING EQUIPMENT PROBLEMS**. To help you recognize this information, we use the symbols below. Please read the manual and pay attention to these sections. **SAVE THESE DEFINITIONS/INSTRUCTIONS.**

▲ **WARNING** indicates a potentially hazardous situation which, if not avoided, **could** result in **death or serious injury**.

▲ **DANGER** indicates an imminently hazardous situation which, if not avoided, **will** result in **death or serious injury**.



▲ **CAUTION** indicates a potentially hazardous situation which, if not avoided, **may** result in **minor or moderate injury**.

10/2/97





IMPORTANT SAFETY INSTRUCTIONS

▲ WARNING

Improper operation or maintenance of this product could result in serious injury and property damage. Read and understand all warnings and operating instructions before using.

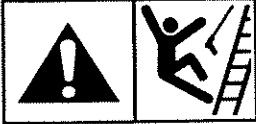
HAZARD	WHAT CAN HAPPEN	HOW TO PREVENT IT
<p style="text-align: center;">▲ DANGER</p> <p style="text-align: center;">RISK OF EXPLOSION OR FIRE</p> 	<ul style="list-style-type: none"> • Spilled gasoline and its vapors can become ignited from cigarette sparks, electrical arcing, exhaust gases, and hot engine components such as the muffler. • Heat will expand fuel in the tank which could result in spillage and possible fire explosion. • Operating the pressure washer in an explosive environment could result in a fire. • Materials placed against or near the pressure washer can interfere with its proper ventilation features causing overheating and possible ignition of the materials. • Improperly stored fuel could lead to accidental ignition. Fuel improperly secured could get into the hands of children or other unqualified persons. 	<ul style="list-style-type: none"> • Shut off engine and allow it to cool before adding fuel to the tank. • Use care in filling tank to avoid spilling fuel. Move pressure washer away from fueling area before starting engine. • Keep maximum fuel level ½" below top of tank to allow for expansion. • Operate and fuel equipment in well ventilated areas free from obstructions. Equip areas with fire extinguishers suitable for gasoline fires. • Never operate pressure washer in an area containing dry brush or weeds. • Store fuel in container approved for gasoline, in a secure location away from work area.
<p style="text-align: center;">▲ DANGER</p> <p style="text-align: center;">RISK TO BREATHING</p> 	<ul style="list-style-type: none"> • Breathing exhaust fumes will cause serious injury or death. • Some cleaning fluids contain substances which could cause injury to skin, eyes, or lungs. 	<ul style="list-style-type: none"> • Operate pressure washer in a well ventilated area. Avoid enclosed areas such as garages, basements, etc. • Never operate unit in a location occupied by humans or animals. • Use only cleaning fluids specifically recommended for high pressure washers. Follow manufacturers recommendations.

IMPORTANT SAFETY INSTRUCTIONS (cont'd)

HAZARD	WHAT CAN HAPPEN	HOW TO PREVENT IT
<p style="text-align: center;">⚠ WARNING RISK OF UNSAFE OPERATION</p> 	<ul style="list-style-type: none"> • Unsafe operation of your pressure washer could lead to serious injury or death to you or others. • The spray gun/wand is a powerful cleaning tool that could look like a toy to a child. • Reactive force of spray will cause gun/wand to move, and could cause the operator to slip or fall, or misdirect the spray. Improper control of gun/wand can result in injuries to self and others. 	<ul style="list-style-type: none"> • Become familiar with the operation and controls of the pressure washer. • Keep children away from the pressure washer at all times. • Never defeat the safety features of this product. • Do not operate machine with missing, broken, or unauthorized parts. • Never leave wand unattended while unit is running. • Keep work area free of obstacles. • Stand on a stable surface and grip gun/wand firmly. Expect the gun to kick when triggered.
<p style="text-align: center;">⚠ WARNING RISK OF INJURY FROM SPRAY</p> 	<ul style="list-style-type: none"> • High velocity fluid spray can cause objects to break, propelling particles at high speed. • Light or unsecured objects can become hazardous projectiles. 	<ul style="list-style-type: none"> • Always wear ANSI approved Z87 safety glasses. Wear protective clothing to protect against accidental spraying. • Never point wand at, or spray people or animals. • Always secure trigger lock when wand is not in service to prevent accidental operation. • Never permanently secure trigger in pull back (open) position.
<p style="text-align: center;">⚠ WARNING RISK OF ELECTRICAL SHOCK</p> 	<ul style="list-style-type: none"> • Spray directed at electrical outlets or switches, or objects connected to an electrical circuit, could result in a fatal electrical shock. 	<ul style="list-style-type: none"> • Unplug any electrically operated product before attempting to clean it. Direct spray away from electric outlets and switches.
<p style="text-align: center;">⚠ WARNING RISK OF FLUID INJECTION</p> 	<ul style="list-style-type: none"> • Your washer operates at fluid pressures and velocities high enough to penetrate human and animal flesh, which could result in amputation or other serious injury. Leaks caused by loose fittings or worn or damaged hoses can result in injection injuries. DO NOT TREAT FLUID INJECTION AS A SIMPLE CUT! See a physician immediately! • Relieve system pressure before attempting maintenance or disassembly of equipment. 	<ul style="list-style-type: none"> • Never place hands in front of nozzle. • Direct spray away from self and others. • Make sure hose and fittings are tightened and in good condition. Never hold onto the hose or fittings during operation. • Do not allow hose to contact muffler. • Never attach or remove wand or hose fittings while system is pressurized. • Use only hose and high pressure accessories rated for 2000 PSI service. • To relieve system pressure, shut off engine, turn off water supply, and pull gun trigger until water stops flowing.
<p style="text-align: center;">⚠ WARNING RISK OF CHEMICAL BURN</p> 	<ul style="list-style-type: none"> • Use of acids, toxic or corrosive chemicals, poisons, insecticides, or any kind of flammable solvent with this product could result in serious injury or death. 	<ul style="list-style-type: none"> • Do not use acids, gasoline, kerosene, or any other flammable materials in this product. Use only household detergents, cleaners and degreasers recommended for use in pressure washers. • Wear protective clothing to protect eyes and skin from contact with sprayed materials.

IMPORTANT SAFETY INSTRUCTIONS (cont'd)

HAZARD	WHAT CAN HAPPEN	HOW TO PREVENT IT
<p>⚠ WARNING RISK OF HOT SURFACES</p> 	<ul style="list-style-type: none"> • Contact with hot surfaces, such as engines exhaust components, could result in serious burn. 	<ul style="list-style-type: none"> • During operation, touch only the control surfaces of the pressure washer. Keep children away from the pressure washer at all times. They may not be able to recognize the hazards of this product.

IMPORTANT:

The powerful spray from your pressure washer is capable of causing damage to fragile surfaces such as: wood, glass, automobile paint, auto stripping and trim, and delicate objects such as flowers and shrubs. Before spraying, check the item to be cleaned to assure yourself that it is robust enough to resist damage from the force of the spray. Avoid the use of the concentrated spray stream except for very strong surfaces like concrete and steel.

Operating unit with water supply shut off without flow of water will result in equipment damage. You should never run this pressure washer for more than 2 minutes without pulling the trigger to allow cool water to enter the pump and the heated (recirculated) water to exit. Running the pressure washer with water supply shut off will void your warranty.

ASSEMBLY

Carton Contents

- Main Unit pressure washer with wheels
- Handle
- High Pressure Hose
- Chemical Pickup Hose and Filter
- Bag Containing
 - Video Cassette
 - Owners' Manual
 - Nozzle Cleaning Kit and Replacement O-Rings
 - Rubber Isolator and Mounting Hardware
- Box Containing
 - Gun
 - Wand
 - Engine Oil
 - Handle Mounting Hardware

Tools Required for Assembly

- Adjustable wrench
- 1/2" Socket wrench

Remove Pressure Washer from Carton

- Open box from the top. Locate and remove from box, the parts box, which includes gun, handle, wand, oil, knobs and J bolts. Next remove the parts bag and the handle.
- Cut carton along dotted lines.
- Remove all carton inserts.

NOTE: The high pressure and chemical hose are located at the bottom of the box.

Preparing the Pressure Washer for First Use

• **Note:** Included with your pressure washer is a video tape on how to prepare your unit for operation. It is recommended you view this tape before performing the next steps.

1. • Insert handle onto frame.
 - Slide J bolts into frame.
 - Tighten knobs turning in clockwise direction.

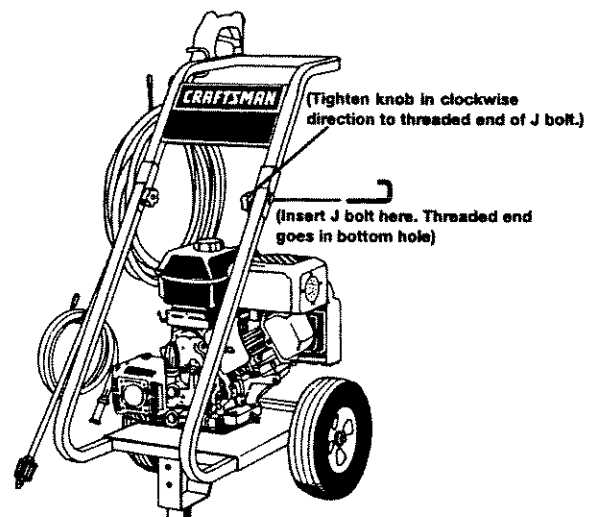

- Remove wood plank from the frame of the unit. An adjustable wrench is required. Discard nut, bolt and board.

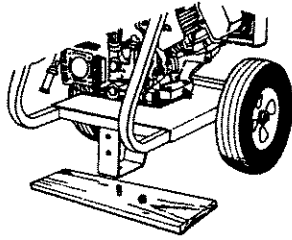

- Mount the rubber isolator to the frame. To mount isolator place threaded end of bolt through the washer. Next with washer on bolt place threaded end of bolt through the rubber isolator. Place threaded portion of isolator through the same hole location the wood plank was mounted to on the pressure washer. Next place lockwasher over threaded portion of nut that has been placed through the mounting hole in the pressure washer and use nut to tighten isolator to the frame. Tighten nut with an adjustable wrench. All isolator parts are supplied in parts bag.

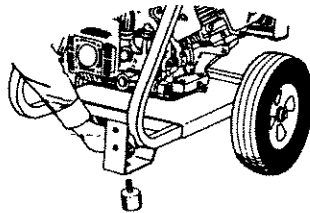
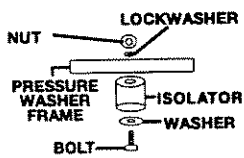

- Connect wand with nozzle extension to gun. To tighten, turn knob in clockwise direction. Hand tighten.

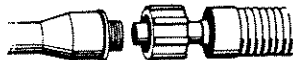

- Cut tie wrap off of high pressure hose. Unwind high pressure hose to attach the threaded end to the gun.

NOTE: Do not remove Telfon tape on threads.

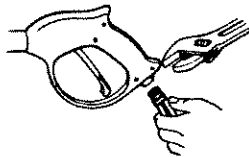

- Connect chemical hose to the chemical injector nipple on the pump.

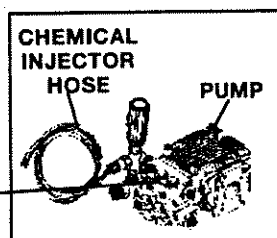
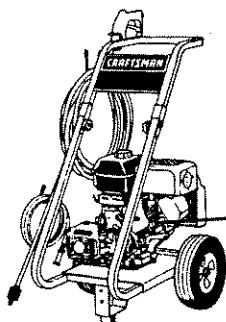

- Connect high pressure hose to the quick connect outlet on pressure washer.

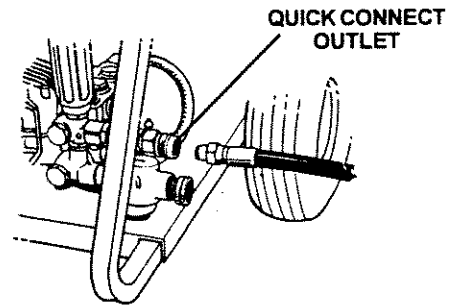

NOTE: Keep hose away from engine muffler.

- Place assembled gun and wand on pressure washer holder.

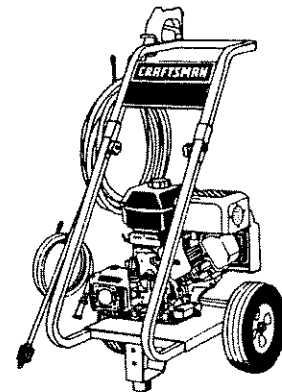

NOTE: Your unit's pump is shipped with a temporary plug that must be replaced with a breather cap. This plug is located over the pump's oil port. Unscrew and remove this plug. Remove the breather cap from the bag attached to the plug and install it in the pump's oil port.

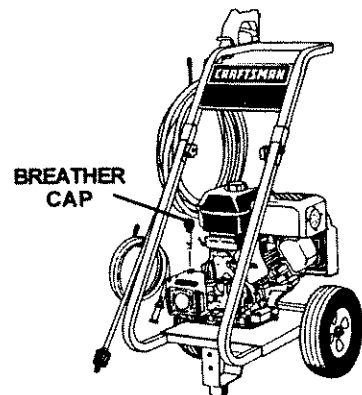

CAUTION: Failure to replace the plug will result in serious pump damage.

Checklist

Before going any further please review the following:

- Be sure you have completed assembly instruction.
- Double check all fittings to be sure they are tight.

IMPORTANT: Before any attempt to start your pressure washer be sure to check engine oil (See Operation under Engine Oil, page 9.)

OPERATION

Know Your High Pressure Washer

Read this Owner's Manual and Safety Rules before operation of your High Pressure Washer Compare this illustration with our pressure washer to familiarize yourself with the location of various controls and adjustments. Save this manual for future reference.

PUMP- Develops high pressure.

ENGINE OIL FILL- Place where engine oil is poured.

PRESSURE REGULATOR- Allows you to adjust the pressure of the outlet stream.

ENGINE RUN/STOP SWITCH- Sets engine in starting mode for recoil starter — **Stops** running engine.

RECOIL STARTER- Used for starting the engine manually.

SPRAY GUN ASSEMBLY- Controls the application of water onto cleaning surface with trigger device.

PUMP OIL FILL- Port where pump oil is poured and breather cap is located.

GAS TANK/CAP- Cap is removed and unleaded gasoline is poured.

CHEMICAL INJECTION TUBE AND FILTER- Mixes water and detergent in outlet water flow.

HIGH PRESSURE OUTLET- Connection for high pressure hose.

CHOKE- Lever used for starting unit.

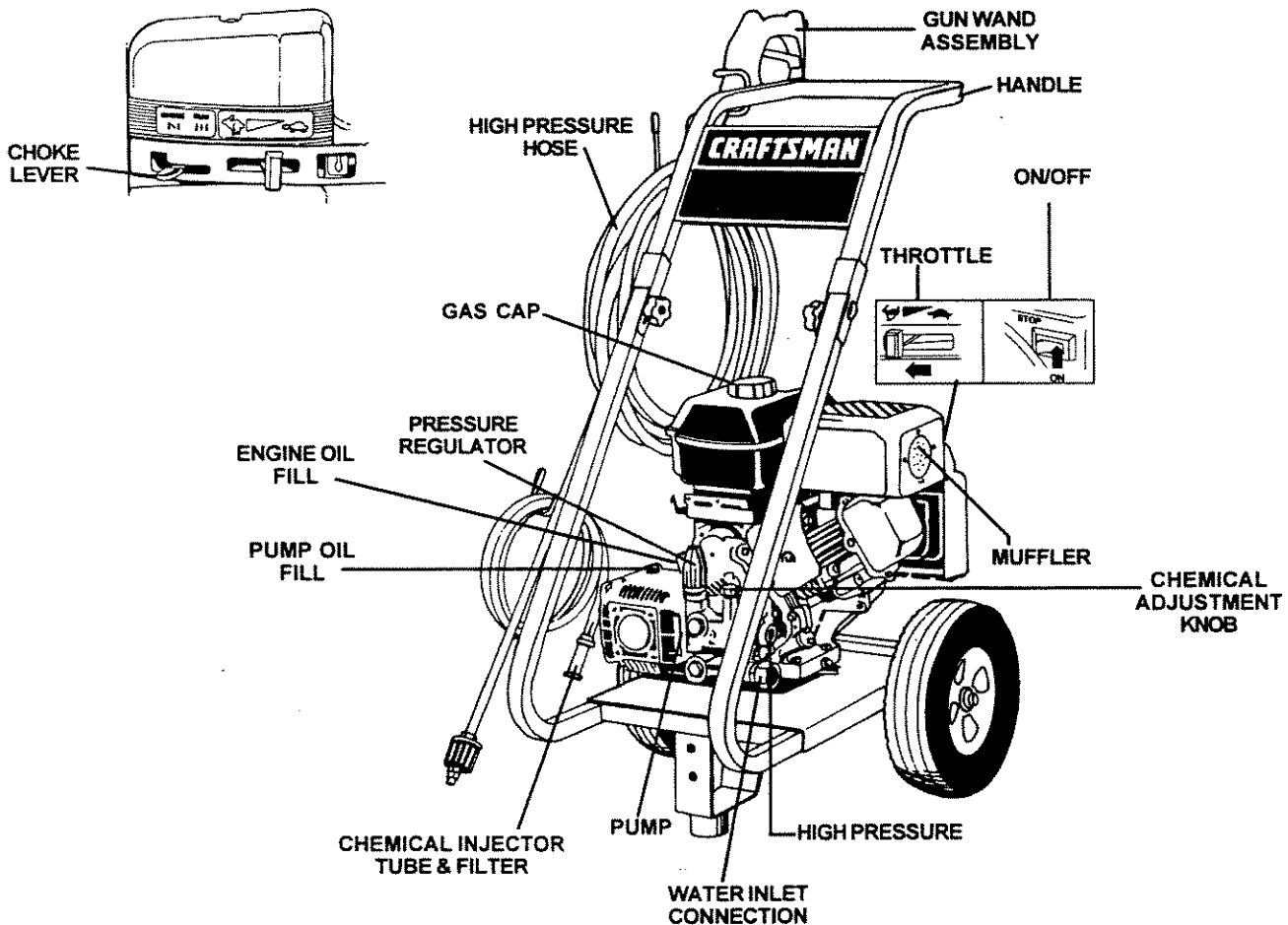

▲ Warning: Read Owner's Manual. Do not attempt to operate equipment until you have read Owners Manual for Safety, Operation, and Maintenance Instructions.

Note: Included with your unit is a video cassette that demonstrates how to operate your pressure washer. If you have a video cassette recorder you should view the video before operation.

▲ Warning: Never adjust spray pattern when spraying. Never put hands in front of spray nozzle to adjust spray pattern because you could be injured.

How To Use Your Pressure Washer

On the end of your spray gun is a nozzle that you can twist from side to side. With the adjustable nozzle you can adjust the nozzle to either high pressure or low pressure.

- Turn the nozzle in a counter clockwise direction to achieve low pressure. Turn nozzle clockwise for high pressure.

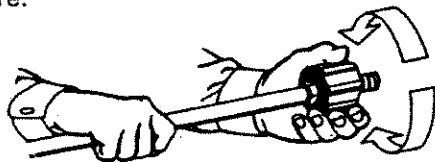

- For most effective cleaning, keep spray nozzle between 8 and 24 inches of cleaning surface.

IMPORTANT: If you get spray nozzle too close, especially on high pressure, you may damage the cleaning surface.

- The pressure control knob is located on the pump. You can increase the pressure by turning the knob clockwise or decrease the pressure by turning the knob counterclockwise.

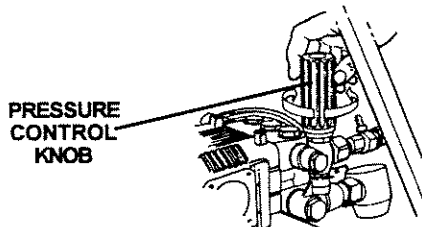

NOTE: The maximum pressure for the unit is factory adjusted. Do not attempt to adjust beyond this factory setting.

Using Soaps/Chemicals

IMPORTANT: Use soaps and chemicals that are designed specifically for use with pressure washers. To apply soap/chemicals follow these steps:

- Prepare the soap/chemical as required by your job.

- Insert soap/chemical line into your container (soap/chemicals not included).



NOTE: The first step involves applying an appropriate soap/chemical solution to penetrate and loosen grime. The soap/chemical applied at low pressure to avoid splashing, over spray and waste. Leave the solution on surface for 3 to 5 minutes to allow solution to work.

NOTE: The second step involves cleaning the surface you have prepared with the pressure washer and then rinsing it clean.

- Turn the adjustable nozzle counter clockwise to low pressure mode. Soap/chemicals cannot be applied with nozzle in high pressure position.
- Review the use of the adjustable nozzle.
- Connect garden hose to water inlet (see "To Start Your Pressure Washer"), check that high pressure hose is connected to spray gun and pump (see Assembly), and start engine.
- Apply soap/chemicals to dry surface, starting from bottom and working up.
- Allow the soap/chemicals to soak in between 3-5 minutes before washing and rinsing.
- For cleaning, start at lower portion of area to be washed and work upward, using long, even overlapping strokes.

Your pressure washer is equipped with a chemical injector adjustment knob. With the knob fully opened you will get a 7 to 1 water to chemical ratio. With knob fully closed you will get **no** chemical draw. Turn knob in counterclockwise direction to achieve more chemical draw and clockwise for less chemical draw.

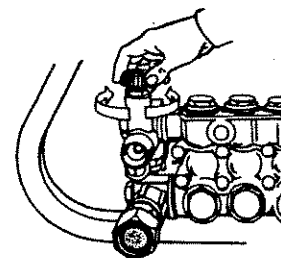

- After using the pressure washer, it is recommended the pump, chemical injector and chemical line be flushed with clear water. To do so, simply place chemical injector hose in water and siphon for 1 to 2 minutes.

Stopping Your Pressure Washer

▲ **CAUTION:** Do not run pump without the water supply connected and turned on. Failure to do so will result in pump damage.

- To turn pressure washer off place the on/off switch to the OFF position.

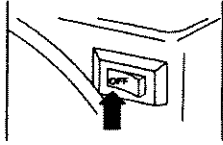

- Simply shutting OFF engine will not release pressure in the system. Squeeze the trigger on the spray gun for about 3 seconds to relieve pressure. Spray stream will decrease in length.

IMPORTANT: This unit is equipped with a thermal relief valve. If unit is allowed to run for several minutes without pressing the trigger on the spray gun, several drops of water may be released through this valve to cool the unit. The heated water will be purged from the bottom of the pump.

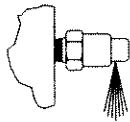

BEFORE STARTING THE ENGINE

To operate the engine you will need to do the following.

▲ **CAUTION:** Always check engine oil level before every start. Running engine low of oil or out of oil could result in serious damage.

▲ **CAUTION:** Always check pump oil level before every start. Running pump low on oil could result in pump damage.

Adding Pump Oil

Before running the high pressure washer, check the pump oil level by viewing the sight glass on the side of the pump. When properly filled, the oil will be at the half way point marked by the two triangles. Your pressure washer pump is shipped with oil. Add oil only if oil level is lower than the half way point on the sight glass. **Do not overfill.** Use 30 weight non-detergent oil if necessary.

▲ **CAUTION:** Do Not use engine oil that has been shipped with your unit in your pump. Engine oil is detergent and your pump uses a non-detergent oil. Detergent oil can cause damage to your pump.

Engine Oil

Your unit has been shipped without oil in the engine. A bottle of SAE 30 weight oil is included in the carton. Remove oil dip stick located on the side of engine. The oil dip stick is clearly marked with a lines that tells you when unit has enough oil. Do not fill above this point. Pour slowly.

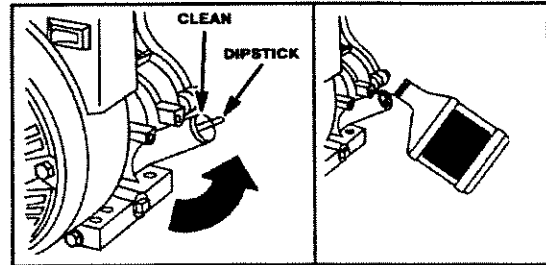

NOTE: When adding oil to the engine crankcase, use a high quality detergent oil classified "For Service SF, SG, SH rated SAE 30 weight. Use no special additives. Select the oil's viscosity grade according to your expected operating temperatures.

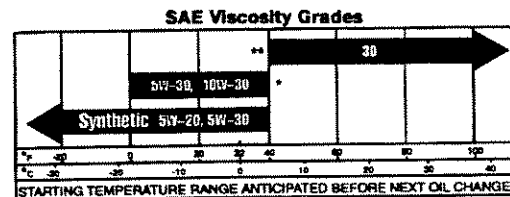

Air cooled engines run hotter than automotive engines. The use of multi-viscosity oil such as (10W-30, etc.) in ambient temperatures above 40°F (4°C) will result in higher than normal oil consumption. If multi-viscosity oil is used, check the oil level more frequently to prevent any possible engine damage due to lack of lubrication. Use of SAE30 oil below 40°F (4°C) will result in hard starting and possible engine damage due to inadequate lubrication.

Gasoline

Your pressure washer engine is 4 cycle. Use unleaded fuel only.

▲ **CAUTION:** Do not overfill the fuel tank. Always allow room for fuel expansion.

▲ **WARNING:** Never fill fuel tank indoors. Never fill fuel tank when engine is running or hot. Do not smoke or have open flame when filling fuel tank.

Use clean, fresh, regular unleaded gasoline with a minimum of 85 octane. Do not mix oil with gasoline. If unleaded fuel is not available, leaded fuel may be used.

IMPORTANT: It is important to prevent gum deposits from forming in essential fuel system parts such as the carburetor, fuel filter hose or tank during storage. Also, experience indicates that alcohol-blended fuels (called gasohol or using ethanol or methanol) can attract moisture which leads to separation and formation of acids during storage. Acidic gas can damage the fuel system of an engine while in storage. To avoid engine problems, the fuel system should be emptied before storage of 30 days or longer. Never use engine or carburetor cleaner products in the fuel tank or permanent damage may occur.

NOTE: Never start pressure washer without water source turned on and connected to pressure washer.

To Start Your Pressure Washer

Make sure fuel shutoff valve is turned to the open position.

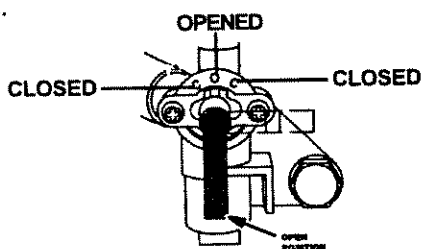

- Remove gas cap
- Add unleaded gasoline, slowly, to fuel tank.
- Do not overfill.

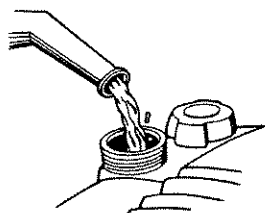

- Connect garden hose to the water inlet on the pressure washer. Tighten by turning water inlet counterclockwise.

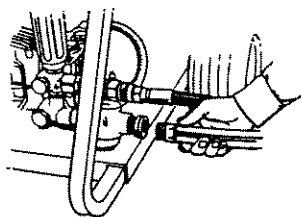

- Connect high pressure hose to discharge on pump.
- Connect the garden hose to the water spout and turn water supply on.

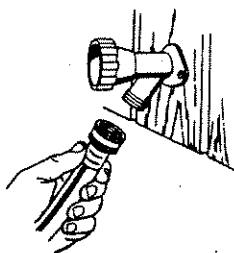

- Squeeze trigger on pressure washer wand to relieve air pressure caused by turning on the water. Water will spew out of the gun in a thin stream. This will make it easier to start the engine.
- Engage the safety latch on the spray gun. This locks the trigger in place and keeps you from accidentally spraying a high pressure stream.

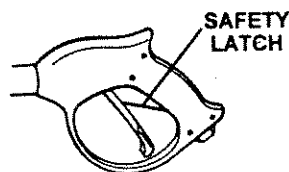

- On the engine there is a choke/run lever. Place lever to the choke position.

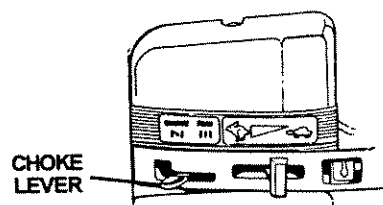

- On the engine there is a throttle control lever. Place throttle to the rabbit position. Always start engine with throttle in the rabbit position. Place on/stop switch to the "on" position.

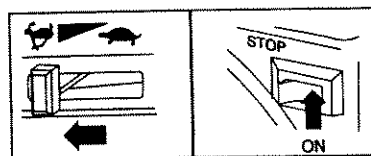

- Grasp the starter grip and pull slowly until resistance is felt, then pull firmly to start engine.
- When engine starts, gradually move choke lever to RUN position.
- If engine does not start after 5 pulls, place choke back to run position.
- For hot engine starts make sure choke lever is in the run position. Make sure fuel shut off valve is open and throttle is in the rabbit position.

NOTE: If any leaks are present shut unit down and tighten fittings.

MAINTENANCE

CUSTOMER RESPONSIBILITIES TABLE

MAINTENANCE TASK	Before each use	Every 25 hours or yearly	Every 50 hours or yearly	Every 100 hours or yearly
PRESSURE WASHER				
Check/clean inlet screen.	x			
Check high pressure hose.	x			
Check soap and chemical hose and filter	x			
Check gun and wand for leaks.	x			
Purge pump of air and contaminants	x			
Check pump oil	x			
Change pump oil			x	
ENGINE				
Check oil level	x			
Change engine oil			x	

Product Specifications

Pressure Washer Specifications

Pressure	2700
Flow Rate	3.0 GPM
Cleaning Units (psi x GPM)	8100

Engine Specifications

RPM	3600
Rated Horsepower	7.5
Spark Plug	0.030" (0.76mm)
Gasoline Capacity	4.6 Quarts
Oil	SAE 30 weight

General Recommendations

The warranty of the high pressure washer does not cover items that have been subjected to operator abuse or negligence. To receive full value from the warranty, operator must maintain high pressure washer as instructed in this manual.

Some adjustments will need to be made periodically to maintain your high pressure washer.

All adjustments in the Maintenance section of this manual should be made at least once each season.

Once a year you should clean or replace the spark plug and clean or replace the air filter and check the gun and wand assembly for wear. A clean spark plug and clean air filter assure proper fuel-air mixture and help your engine run better and last longer.

NOTE: Over time the o-rings in the gun assembly become worn. Attached to your owners manual is a replacement o-ring and split backup ring.

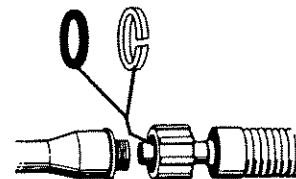

Pressure Washer Maintenance

Check and Clean Inlet Screen: Examine inlet screen on pump inlet fitting. Clean if clogged replace if torn.

Check High Pressure Hose: High pressure hose can develop leaks from wear, kinking, abuse. Inspect hose each time before use. Check for cuts, leaks, abrasions or bulging of cover, damage or movement of couplings. If any of these conditions exist, replace hose immediately.

Check Chemical/Soap Hose: Examine the chemical/soap hose and clean if clogged. Hose should fit tightly on pump fitting. Check for leaks and tears. Replace filter or hose if either is damaged.

Check Gun and Wand: Examine hose connection to gun making sure it is secure. Test trigger by pressing it and making sure it springs back into place when you release it.

Pump Oil

Pump oil level should be checked before each use.

Changing Pump Oil

Oil should be changed after the first 10 hours of operation. Subsequent changes after each 50 hours of operation. To drain oil, simply remove oil plug with an adjustable wrench. The oil plug is located at the bottom of the pump. Dispose of used oil. Properly remove pump oil fill plug. Add 30 weight non-detergent oil. Fill until oil level is at the mid point on the sight glass.

Purge Pump of Air and Contaminants

To remove the air from the pump, follow these steps:

- Set up the pressure washer as described in *Assembly* section and connect the water supply.
- Remove the wand extension from the spray gun.
- Pull the trigger on the gun and hold.

To remove the contaminants from the pump, follow these steps:

- Set up the pressure washer as described in *ASSEMBLY* section, connect the water supply.
- Remove the wand extension from the spray gun.
- Start the engine according to instructions in the *OPERATION* section.

- Pull the trigger on the gun and hold.
- When the water supply is steady and constant, disengage trigger and refasten the wand extension.

Engine Maintenance

Oil

- Oil level should be checked prior to each use or at least every 5 hours of operation. To check oil see *Adding Engine Oil* on page 9.

Changing Engine Oil

For a new engine, change oil after the first 5 hours of operation. Thereafter, change oil after every 50 hours of operation.

Change the oil while the engine is still warm. The oil will flow freely and carry away more impurities. Make sure the engine is level when filling, checking, or changing oil.

Change the oil as follows:

- To keep dirt, grass clippings, etc., out of the engine, clean the area around the drain plug and dipstick before removing it.
- Remove the oil drain plug and dipstick. Tilt the engine slightly towards the oil drain to obtain better drainage. Be sure to allow ample time for complete drainage.

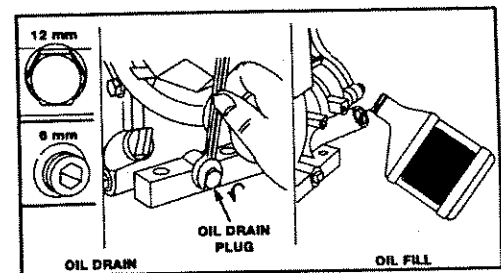

- Reinstall the drain plug. Make sure it is tightened securely.
- Fill the crankcase with new oil of the proper type, to the Full mark on the dipstick. Always check the level with the dipstick before adding more oil.

- Reinstall the oil fill cap or plug and tighten securely.

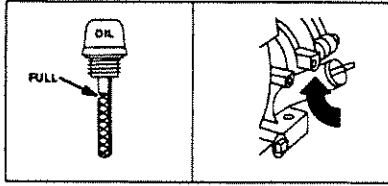

Do not clean engine with a forceful spray of water because water could contaminate fuel system. With a brush or cloth clean finger guard after every use to prevent engine damage caused by overheating.

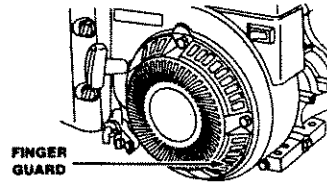

Service Air Cleaner

NOTE: Do not use petroleum solvents, e.g., kerosene, which will cause the cartridge to deteriorate. Do not use pressurized air to clean cartridge. Pressurized air can damage the cartridge.

To service air cleaner follow these steps:

1. Unscrew cover screws. Remove cover and air cleaner assembly.
2. Remove cartridge from cover, then retainer (if equipped) and pre-cleaner.

To service pre-cleaner, wash in liquid detergent and water. Squeeze dry in a clean cloth. Saturate in engine oil. Squeeze in clean, absorbent cloth to remove all **excess** oil. Replace if very dirty or damaged.

To service cartridge, clean by tapping gently on a flat surface. Do not oil cartridge. Replace if dirty or damaged.

NOTE: Do not use petroleum solvents, e.g., kerosene, which will cause the cartridge to deteriorate. Do not use **pressurized air** to clean cartridge. Pressurized air can damage the cartridge.

3. Reassemble pre-cleaner or retainer (if equipped.) Place in cover with pre-cleaner mesh side toward cartridge. Place cartridge in retainer in cover.
4. Push cover and air cleaner assembly squarely onto base (tabs must be in slots, if equipped) and hold firmly. Tighten cover screws securely.

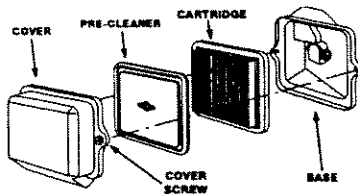

Keep engine and parts clean!

Before running engine, clean muffler area to remove all combustible debris.

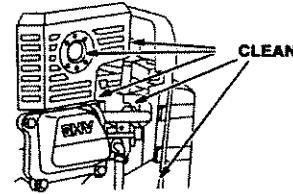

Clean and Replace Spark Plug

Change the spark plug every 100 hours of operation or once each year, whichever comes first. This will help your engine to start easier and run better.

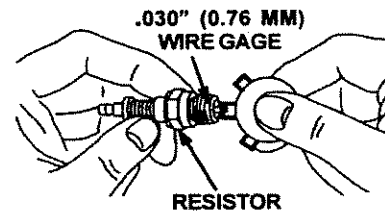

SERVICE AND ADJUSTMENTS

Carburetor

The carburetor of your high pressure washer is pre-set at the factory. The carburetor should not be tampered with. If your pressure washer is used at an altitude in excess of 5000 feet consult with your nearest Sears Service Center regarding high altitude set changes.

▲ CAUTION: Engine speed was properly adjusted at the factory and should require no additional adjustment. Do not attempt to change engine speed. If you believe the engine is running too fast or too slow, take your pressure washer to a Sears Authorized Service Center for repair and adjustment.

▲ WARNING: High engine speeds are dangerous and increase the risk of personal injury or damage to equipment.

▲ CAUTION: Low engine speeds impose a heavy load on the engine and when sufficient engine power is not available could shorten engine life.

Nozzle Maintenance

Hi-Low Lance:

1. Shut off the pressure washer and turn off the water supply.
2. Disconnect spark plug wire.
3. Pull trigger on gun handle to relieve any water pressure.
4. Disconnect the wand/lance from the gun.
5. Remove the high-pressure nozzle from the lance. Remove any obstructions with the nozzle cleaning tool provided and backflush with clean water.
6. Direct water supply into nozzle end to backflush loosened particles for 30 seconds.
7. Reassemble the nozzle to the lance using teflon tape to prevent leaks. Tighten securely.
8. Reconnect wand/lance to gun and turn on water supply.
9. Start pressure washer and place wand/lance into high pressure setting to test.

STORAGE

This pressure washer should be stored in such a way to protect it from freezing. Do not store this unit outdoors or in an area where temperatures will fall below 32° F. This can cause extensive damage to this unit.

If unit has to be stored under freezing conditions a non-toxic R.V. anti-freeze can be used to protect from freezing.

Preparing Pressure Washer for Storage

NOTE: If you do not plan to use your unit for 30 days or more, unit should be prepared for storage.

Engine Preparation

- First add a fuel stabilizer to the fuel tank.
 - Run pressure washer for full 5 minutes to allow fuel stabilizer to enter the fuel system.
- NOTE:** While doing this procedure make sure water supply is turned on and flowing to the unit. **NEVER** run unit without water supply running through pump.
- Next shut off engine and disconnect the water supply.
 - Disconnect the spark plug wire and remove the spark plug.

- Add one teaspoon of oil through the spark plug hole.
- Place rag over spark plug hole and pull the recoil a few times to lubricate the combustion chamber.
- Replace the spark plug, but do not connect the spark plug wire.

Pump Preparation

- Be sure engine switch is in "OFF" position and spark plug wire has been removed from spark plug.
- Pull the trigger on the spray gun to release the pressure in the high pressure hose. Detach high pressure hose and garden hose from the unit.
- Pull the recoil on the engine 4 to 6 times to discharge remaining water in pump.
- Tip the unit on the end with the water inlet fitting pointing upward.
- Pour approximately 1/4 cup of non-toxic R.V. anti-freeze down the fitting where the water hose attaches to the pump.
- Set unit upright and pull starter handle on engine 4 to 6 times to circulate anti-freeze in pump until anti-freeze is discharged from the pump.

TROUBLESHOOTING

SYMPTOM	CAUSE	SOLUTION
Engine won't start	<ol style="list-style-type: none"> 1. Engine throttle is in "OFF" Position. 2. Choke lever has not been placed to choke. 3. Pressure buildup after initial use. 	<ol style="list-style-type: none"> 1. Slide throttle to "Rabbit" position. 2. Slide choke lever to choke position. 3. Depress trigger gun.
Won't Draw Chemical	<ol style="list-style-type: none"> 1. Nozzle not in chemical draw position. 2. Chemical screen is obstructed. 3. Chemical screen not working. 4. Chemical injector orifice obstructed or stuck. 5. Chemical injector closed. 	<ol style="list-style-type: none"> 1. Place nozzle to low pressure. 2. Check chemical screen; clean if obstructed. 3. Make sure chemical screen is submerged in chemical/water. 4. Check and clean. 5. Open chemical injector by turning adjustment knob.
Pump running normally but pressure does not achieve rated values	<ol style="list-style-type: none"> 1. Water supply restricted. 2. Nozzle is in low PSI position. 3. Nozzle incorrect or worn. 4. Pump sucking air. 5. Nozzle blocked. 	<ol style="list-style-type: none"> 1. Check water supply and filter screen for blockage. Check hoses for blockage, kinks, leaks, etc. 2. Pull nozzle at end of wand back to the high pressure position. 3. Check and replace. 4. Check that hoses and fittings are air-tight. 5. Clean nozzle.
Fluctuating Pressure	<ol style="list-style-type: none"> 1. Pump sucking air. 2. Garden hose inlet strainer clogged. 3. Worn Seals or Packing. 4. Inadequate water supply. 5. Fouled or dirty inlet or discharge valves. 6. Leaky discharge hose. 	<ol style="list-style-type: none"> 1. Check that hoses and fittings are air tight. Purge air from garden hose. 2. Clean. Check filter frequently. 3. Check and replace. 4. Check hose for kinks. 5. Check flow available to pump. Check for excessive heat, 145° F or above. 6. Clean inlet and discharge valve assemblies. Replace if damaged.
Pressure drops after period of normal use	<ol style="list-style-type: none"> 1. Nozzle clogged, partially obstructed. 2. Nozzle worn. 3. Pump Valves worn, dirty or stuck. 4. Worn pump piston packing. 	<ol style="list-style-type: none"> 1. Use nozzle cleaning kit to clear obstruction. (See Nozzle Maintenance under Service Adjustment.) 2. Clean or replace. 3. Check and replace. 4. Check and replace.
Pump noisy	<ol style="list-style-type: none"> 1. Water too hot. 2. Pump sucking air. 3. Valves dirty or worn. 4. Worn bearings. 	<ol style="list-style-type: none"> 1. Reduce temperature below 63° C or 145° F. 2. Check that hoses and fittings are air tight. 3. Check, clean or replace. 4. Check and replace if necessary.
Presence of water in oil (oil milky).	<ol style="list-style-type: none"> 1. High humidity. 2. Piston packing and oil seal worn. 	<ol style="list-style-type: none"> 1. Change Oil. 2. Check and replace oil seals.
Water dripping from pump	<ol style="list-style-type: none"> 1. Thermal relief functioning normal. 2. Fittings Loose. 3. O-rings of piston guide or retainer worn. 4. Piston packing worn. 	<ol style="list-style-type: none"> 1. Protecting pump, if not using pressure washer for a long period of time, shutoff engine. 2. Tighten. 3. Check and replace. 4. Check and replace.
Oil Dripping	<ol style="list-style-type: none"> 1. Oil seal worn 2. Loose drain plug or worn drain plug o-ring. 	<ol style="list-style-type: none"> 1. Check and replace 2. Tighten drain plug or replace O-ring. Do not over torque.

PARTS

CRAFTSMAN 2700 PSI HIGH PRESSURE WASHER 919.762700

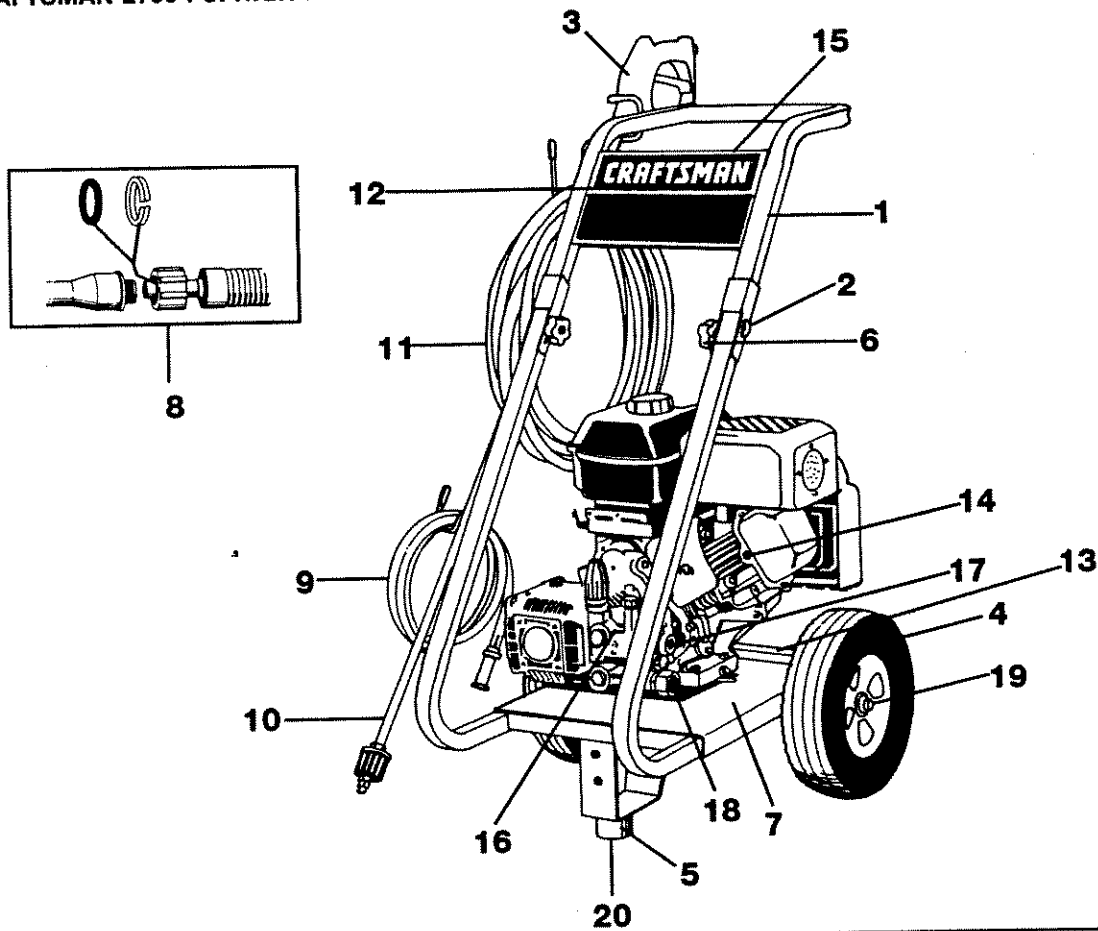

KEY #	PART NUMBER	DESCRIPTION
1	16532	Handle
2	16470	J Bolt
3	16396	Gun
4	16535	Tire Pnuematic
5	16371	Foot Rubber
6	16471	Knob
7	16503	Frame
8	P657	O-ring Kit
9	H100	Chemical Hose and Filter
10	15043	Lance Hi/Low
11	15111	High Pressure Hose
12	16529	Decal Front Craftsman
13	T527-04	Axe
14		Engine
15	16727	Decal Operation
16	PK16803	Pump
17	F035	High Pressure Quick Connect
18	P655	Adapter- Garden Hose
19	F464	Nut Pal 5.8"
20	F064	Screw Hex HDC

PARTS NOT ILLUSTRATED

MGP-762700 Owners Manual

F078 Lockwasher, Engine to Frame

F119 Nut Hex 5/16"- Engine to Frame

F066 Screw 5/16"- Engine to Frame

F107 Lockwasher- Pump to Engine

16106 Srew, Hex- Pump to Engine

F074 Flat Washer - Pump to Engine

NCT001 Nozzle Cleaning Tool

16776 Easy Start Valve

PUMP PARTS

CRAFTSMAN 2700 PSI HIGH PRESSURE WASHER

919.762700PUMP NUMBER PK16803

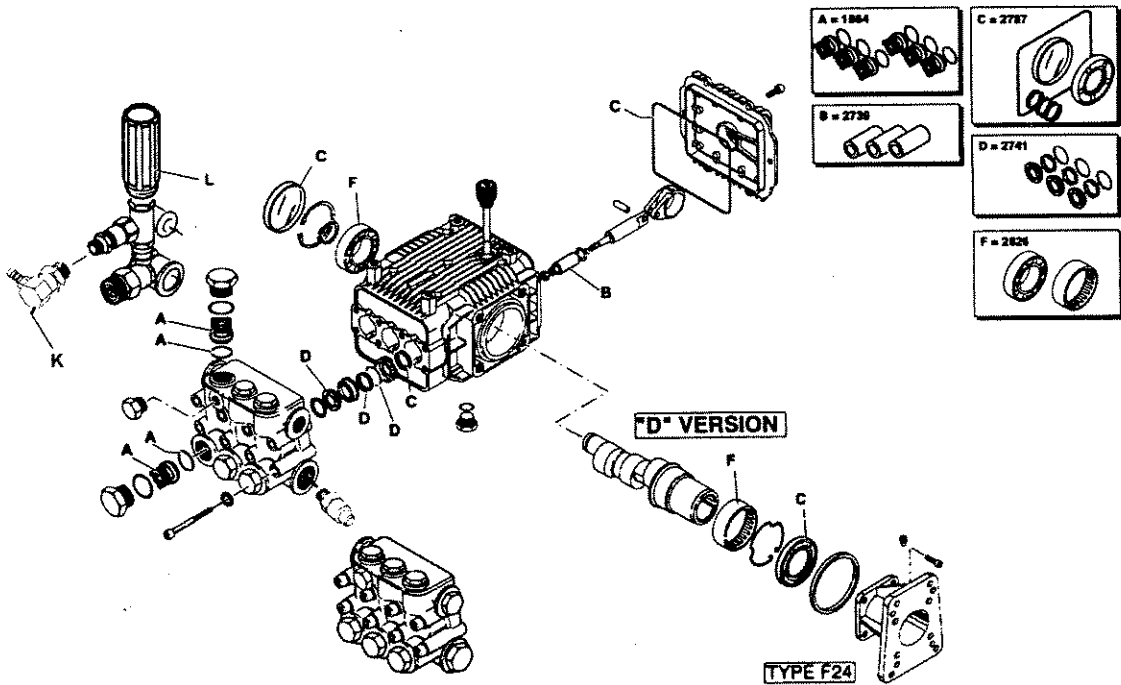
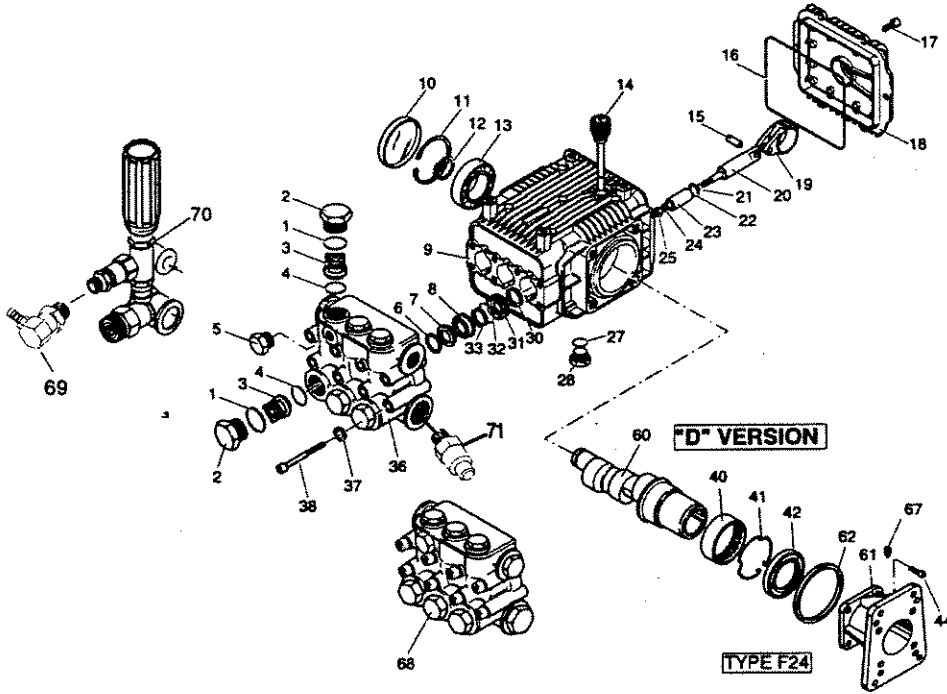

PUMP PARTS

CRAFTSMAN 2700 PSI HIGH PRESSURE WASHER 919.762700

PUMP NUMBER PK16803

REF. NO.	PART NO.	DESCRIPTION	QTY.	REF. NO.	PART NO.	DESCRIPTION	QTY.
1	AR-960160	O-Ring	6	23	AR-1780070	Piston	3
2	AR-1260162	Plug	6	24	AR-1260100	Piston washer	3
3	AR-1269050	Complete valve	6	25	AR-1260110	Nut	3
4	AR-880830	O-Ring	6	27	AR-740290	O-Ring	2
5	AR-620301	Plug	1	28	AR-880530	Plug	2
6	AR-1780130	Support ring	3	30	AR-1260460	Seal	3
7	AR-1260130	Gasket	3	31	AR-1780100	Rear piston guide	3
8	AR-1780090	Piston guide	3	32	AR-770260	O-Ring	3
9	AR-1780010	Pump body	1	33	AR-1260440	Gasket	3
10	AR-1266740	Cap	1	36	AR-1780380	Head	1
11	AR-1260790	Circlip	1	37	AR-1381550	Washer	8
12	AR-1780550	Snap ring	1	38	AR-680570	Screw	8
13	AR-1780490	Bearing	1	40	AR-1321160	Bearing	1
14	AR-880130	Oil cap	1	41	AR-1321080	Snap ring	1
15	AR-1780050	Piston pin	3	42	AR-480671	Seal	1
16	AR-1780510	O-Ring	1	44	AR-180030	Screw	4
17	AR-1200430	Screw	6	60	AR-1780340	Hollow shaft 0 1	1
18	AR-1789010	Complete cover	1	61	AR-1380550	Gas engine flange	1
19	AR-1780040	Con rod	3	62	AR-1780430	13ushing	1
20	AR-1780060	Guiding piston	3	67	AR-820440	Grub screw	1
21	AR-480480	O-Ring	3	68	AR-1789200	Pump head pre-ass	1
22	AR-1260091	Spacer disc	3	69	16802	Chemical Injector	1
				70	16749	Unloader	
				71	16506	Thermal Relief Valve	1

PARTS KITS							
A=KIT 16739 Valves		B=KIT 16746 Pistons		C=KIT 16748 Oil Seals for D Version			
Pos.	Qty.	Pos.	Qty.	Pos.	Qty.		
3	6	23	3	10	1		
4	6			16	1		
				30	3		
				42	1		
D=KIT 16745 Water Seals		F=KIT 16749 Bearings		L=KIT 16750 Unloader		K=KIT 16802	
Pos.	Qty.	Pos.	Qty.	Pos.	Qty.	Pos.	Qty.
7	3	13	1	70	1	69	1
32	3	40	1				
33	3						

ENGINE PARTS

CRAFTSMAN 2700 PSI HIGH PRESSURE WASHER 919.762700

ENGINE NUMBER 138432-0035-A1

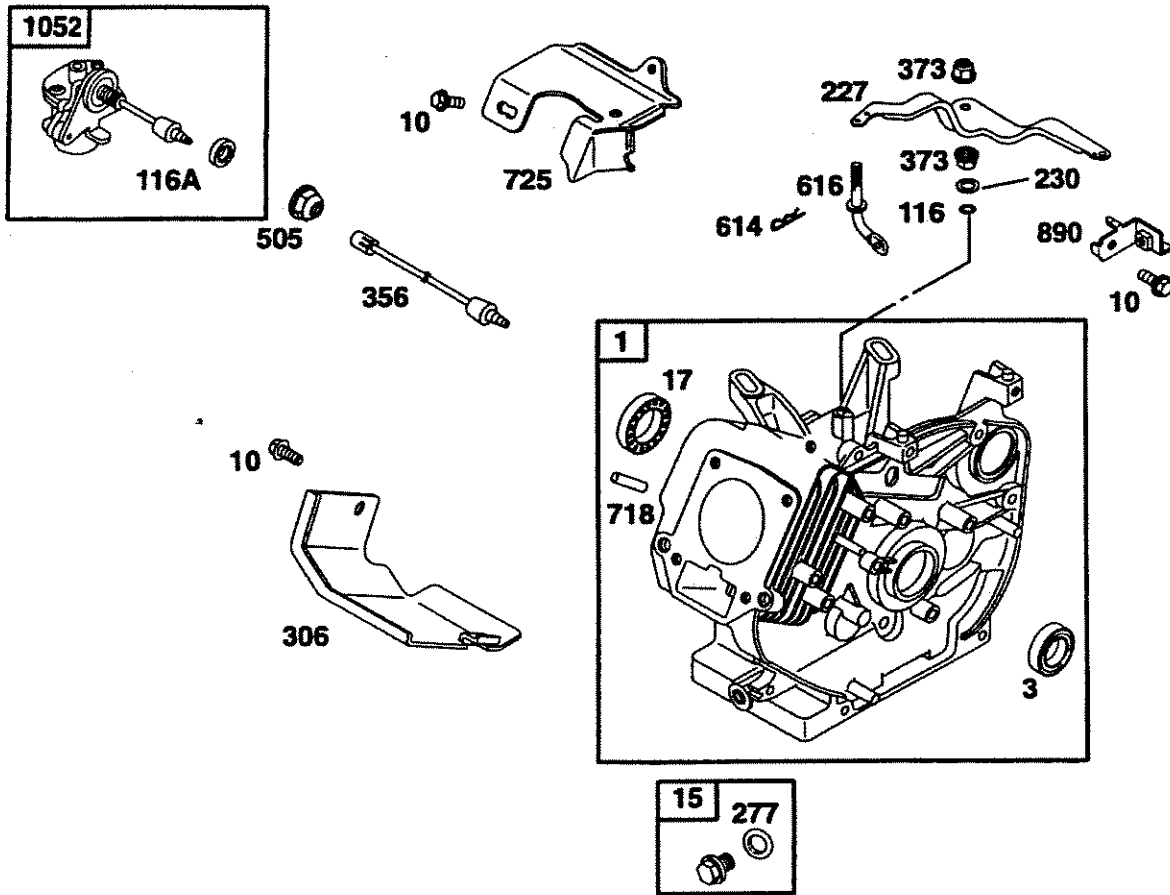

REF. NO.	PART NO.	DESCRIPTION	REF. NO.	PART NO.	DESCRIPTION	REF. NO.	PART NO.	DESCRIPTION
1	715461	Cylinder Assembly	10	710023	Screw-Hex	373	710059	Nut-Lock
3	●710000	Seal-Oil	15	715000	Plug-Oil Drain	505	710090	Nut-Lock
			17	710003	Bearing-Ball	614	710056	Pin-Retainer
			116	●710055	Seal-O-Ring	616	710636	Crank-Governor
			116A	●710091	Seal-O-Ring	718	710005	Pin-Locating
			227	710051	Lever-Governor	725	710102	Shield-Heat
			230	●710058	Washer-Spacer	890	715136	Bracket-Support
			277	710004	Washer-Seal	1019	715031	Label Kit
			306	710063	Shield-Cylinder	1052	715353	Sensor-Oil
			356	710308	Wire-Oil Sensor	1058	273126	Owner's Manual

- Included in Gasket Set-Part No. 715482
- ★ Included in Valve Overhaul Kit-Part No. 715483
- ▲ Included in Carburetor Kit-Part No. 715484
- ✦ Included in Gasket Gasket Set -Part No. 715485

ENGINE PARTS

CRAFTSMAN 2700 PSI HIGH PRESSURE WASHER 919.762700

ENGINE NUMBER 138432-0035-A1

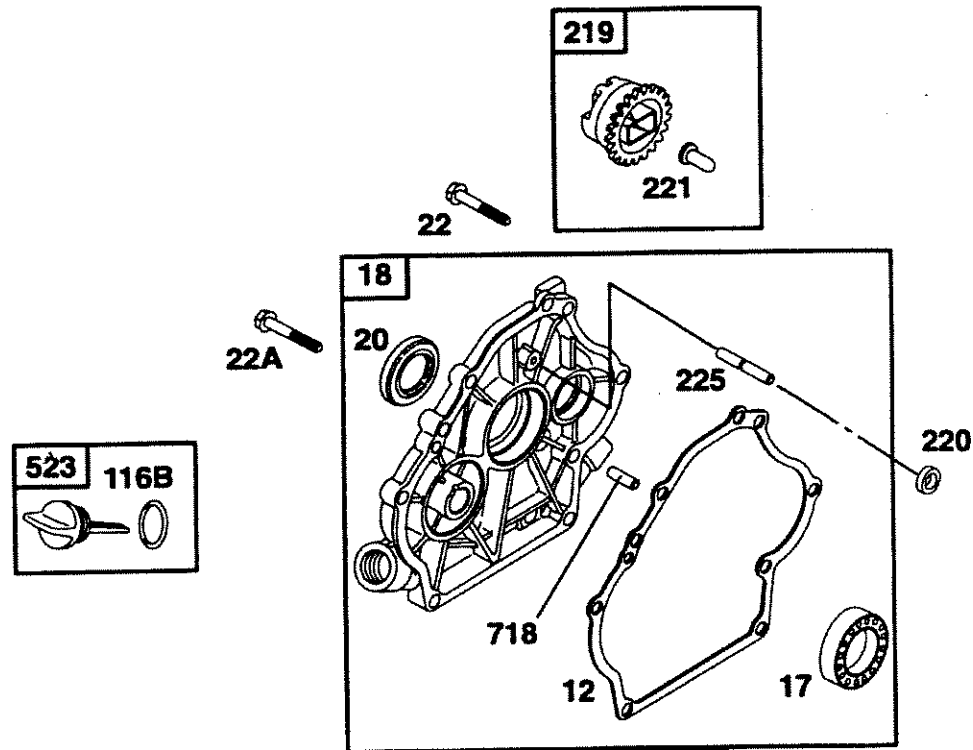

REF. NO.	PART NO.	DESCRIPTION	REF. NO.	PART NO.	DESCRIPTION	REF. NO.	PART NO.	DESCRIPTION
12	● 710628	Gasket-Crankcase	22A	710306	Screw-Hex	221	710027	Cup-Governor
17	● 710003	Bearing-Ball	116B	● 710029	Seal-O-Ring	225	710028	Shaft-Governor Gear
18	715463	Cover-Crankcase	219	715341	Gear-Governor	523	715007	Dipstick
20	● 710215	Seal-Oil	220	710035	Washer-Spacer	718	710005	Pin-Locating
22	710032	Screw-Hex.						

- Included in Gasket Set-Part No. 715482
- ★ Included in Valve Overhaul Kit-Part No. 715483
- ▲ Included in Carburetor Kit-Part No. 715484
- ◆ Included in Gasket Gasket Set -Part No. 715485

ENGINE PARTS

CRAFTSMAN 2700 PSI HIGH PRESSURE WASHER 919.762700

ENGINE NUMBER 138432-0035-A1

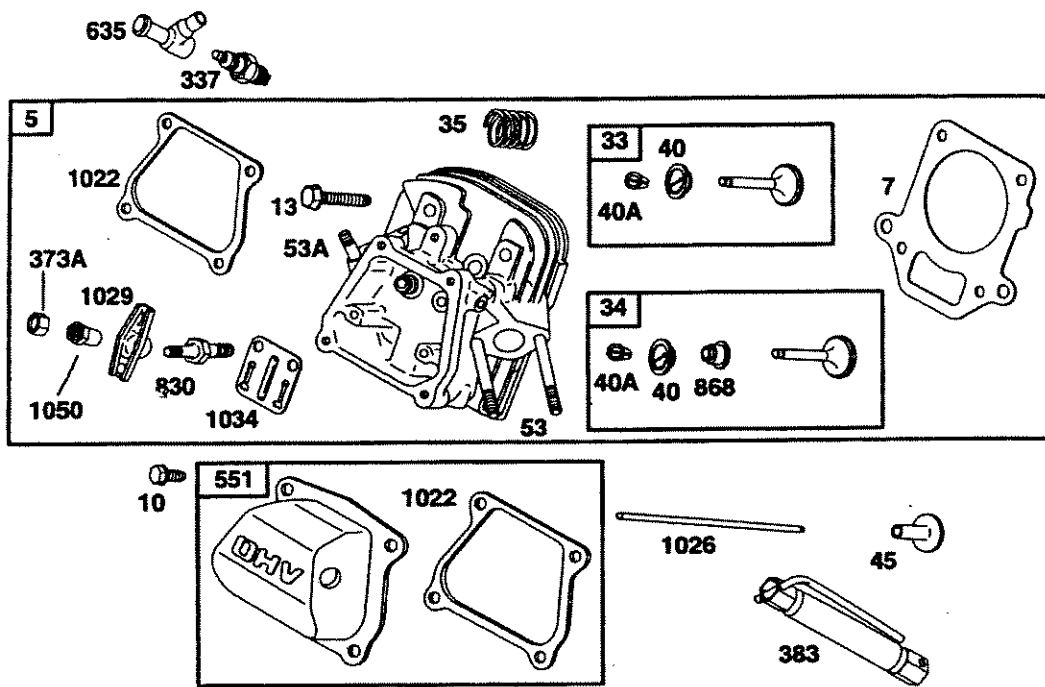

REF. NO.	PART NO.	DESCRIPTION	REF. NO.	PART NO.	DESCRIPTION	REF. NO.	PART NO.	DESCRIPTION
5	715444	Head-Cylinder	45	710008	Tappet-Valve	635	710634	Boot-Spark Plug
7	●★710624	Gasket-Cylinder Head	53	710148	Stud-Carburetor Mounting	830	710016	Stud-Rocker Arm
10	710023	Screw-Hex	53A	710099	Stud (Muffler Mounting)	868	●710019	Seal-Valve
13	710020	Screw-Hex				1022	●★710626	Gasket-Rocker Cover
33	715445	Valve-Exhaust	337	491055	Plug-Spark	1026	710622	Rod-Push
34	715446	Valve-Intake	373A	710007	Nut-Lock	1029	710014	Arm-Rocker
35	710011	Spring-Valve	383	19374	Wrench-Spark Plug	1034	710017	Guide-Push Rod
40	710012	Retainer-Valve	551	715450	Cover-Rocker	1050	710015	Adjuster-Rocker Arm
40A	715130	Retainer-Valve						

● Included in Gasket Set-Part No. 715482

★ Included in Valve Overhaul Kit-Part No. 715483

▲ Included in Carburetor Kit-Part No. 715484

◆ Included in Gasket Gasket Set -Part No. 715485

ENGINE PARTS

CRAFTSMAN 2700 PSI HIGH PRESSURE WASHER 919.762700

ENGINE NUMBER 138432-0035-A1

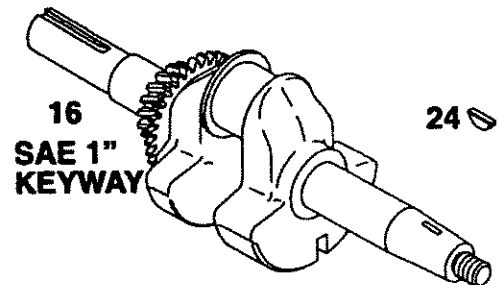
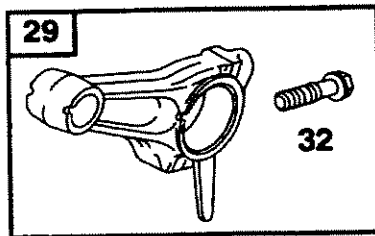
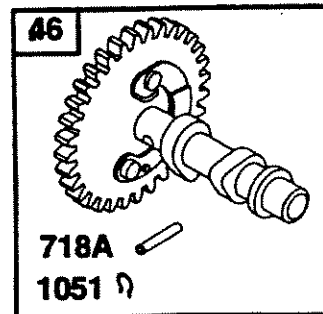
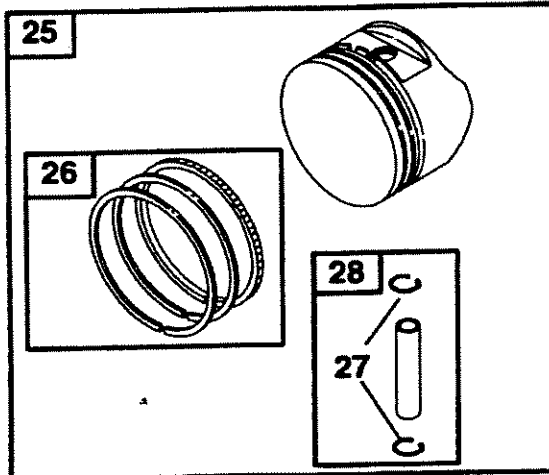

REF. NO.	PART NO.	DESCRIPTION	REF. NO.	PART NO.	DESCRIPTION	REF. NO.	PART NO.	DESCRIPTION
16	715426	Crankshaft Used on Type No(s). 0035, 0084	25	715456	Piston Assy. (Standard)	27	710040	Lock-Piston Pin
				715457	Piston Assy. (.010" O.S.)	28	715455	Pin-Piston Std.
				715448	Piston Assy. (.020" O.S.)	29	715427	Rod-Connecting (Standard)
			26	715452	Ring Set (Standard)		715502	Rod-Connecting (.020" Undersize)
				715453	Ring Set (.010" O.S.)	32	710041	Screw-Connecting Rod
				715454	Ring Set (.010" O.S.)	46	715451	Gear-Cam
						718A	710616	Pin-Compression
						1051	710039	Ring-Retaining

- Included in Gasket Set-Part No. 715482
- ★ Included in Valve Overhaul Kit-Part No. 715483
- ▲ Included in Carburetor Kit-Part No. 715484
- ◆ Included in Gasket Gasket Set -Part No. 715485

ENGINE PARTS

CRAFTSMAN 2700 PSI HIGH PRESSURE WASHER 919.762700

ENGINE NUMBER 138432-0035-A1

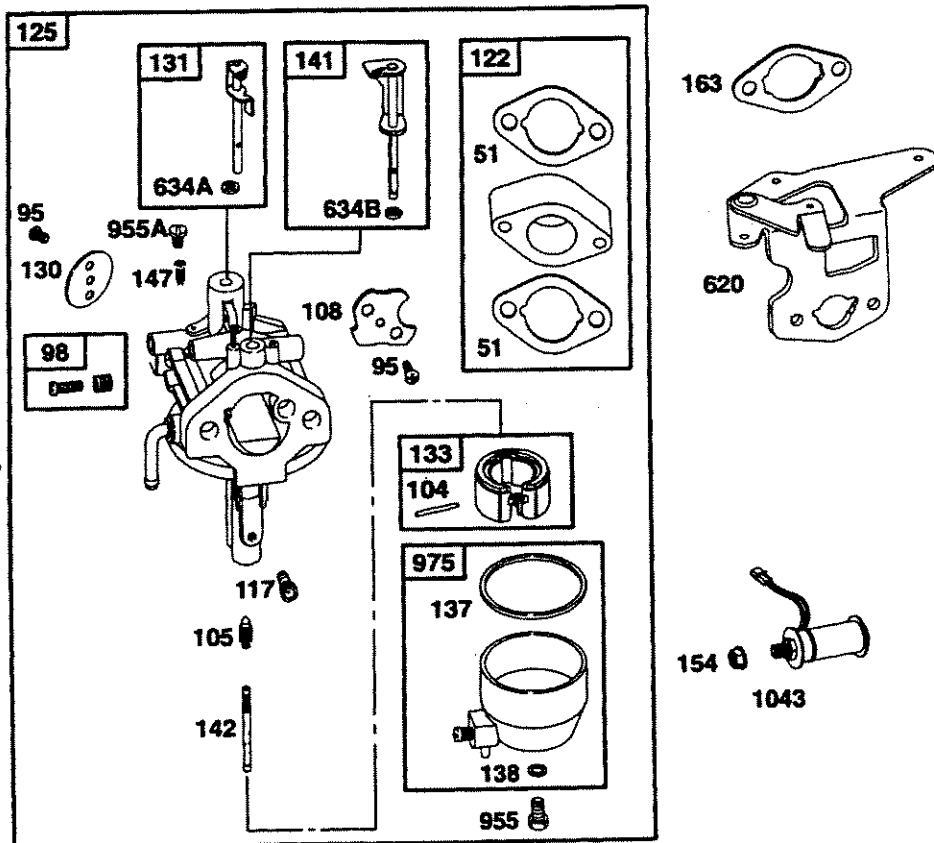

REF. NO.	PART NO.	DESCRIPTION	REF. NO.	PART NO.	DESCRIPTION	REF. NO.	PART NO.	DESCRIPTION
51	●★▲+710060	Gasket-Intake	130	710671	Valve-Throttle	634A	●	Seal-Throttle Shaft (Sold in Kit Only)
95	710672	Screw-Round Head	131	715480	Shaft-Throttle	634B	●	Bushing-Choke Shaft (Sold in Kit Only)
98	715478	Screw-Idle Speed	133	715477	Float-Carburetor	955	710667	Screw-Bowl Mounting
104	● 710663	Pin-Float	137	●+	Gasket-Float Bowl (Sold in Kit Only)	955A	710679	Plug-Carburetor
105	● 710661	Valve-Needle	138	●+	Washer (Sold in Kit Only)	975	715476	Bowl-Float
108	710674	Valve-Choke	141	715479	Choke Shaft Kit			
117	● 710665	Jet-Main	142	● 710664	Nozzle-Carburetor			
		- NOTE -	147	● 710675	Jet-Pilot			
	710719	Jet-Main (High Altitude)			- NOTE -			
122	715034	Spacer-Carburetor		710720	Jet-Pilot (High Altitude)			
125	715473	Carburetor	154	710081	Nut-Hex			
			163	●★▲+710639	Gasket-Air Cleaner			
			620	710635	Bracket-Control			

- Included in Gasket Set-Part No. 715482
- ★ Included in Valve Overhaul Kit-Part No. 715483
- ▲ Included in Carburetor Kit-Part No. 715484
- + Included in Gasket Gasket Set -Part No. 715485

ENGINE PARTS

CRAFTSMAN 2700 PSI HIGH PRESSURE WASHER 919.762700

ENGINE NUMBER 138432-0035-A

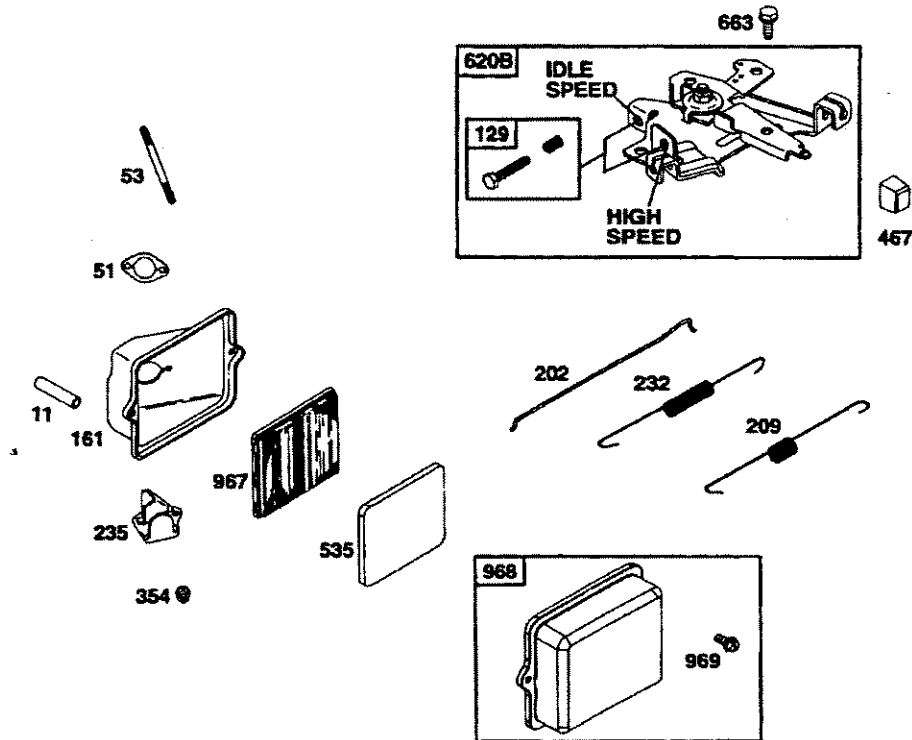

REF. NO.	PART NO.	DESCRIPTION	REF. NO.	PART NO.	DESCRIPTION	REF. NO.	PART NO.	DESCRIPTION
11	710115	Tube-Breather	202	710637	Link-Mechanical Governor	620B	715025	Bracket-Control
51	710060	Gasket-Intake	209	710702	Spring-Governor	663	710057	Screw-Hex
53	710148	Stud-Carburetor Mounting	232	710638	Spring-Link	967	491588	Air Filter
129	715024	Screw-Governor Speed (High and Idle Speed Adjustment)	235	710522	Shield-Fuel Spray	968	495872	Cover-Air Cleaner
161	710521	Base-Air Cleaner	354	710068	Nut-Hex	969	93473	Screw-Hex
			467	280715	Knob-Control			
			535	491435	Filter-Air			

- Included in Gasket Set-Part No. 715482
- ★ Included in Valve Overhaul Kit-Part No. 715483
- ▲ Included in Carburetor Kit-Part No. 715484
- ◆ Included in Gasket Gasket Set -Part No. 715485

ENGINE PARTS

CRAFTSMAN 2700 PSI HIGH PRESSURE WASHER 919.762700

ENGINE NUMBER 138432-0035-A1

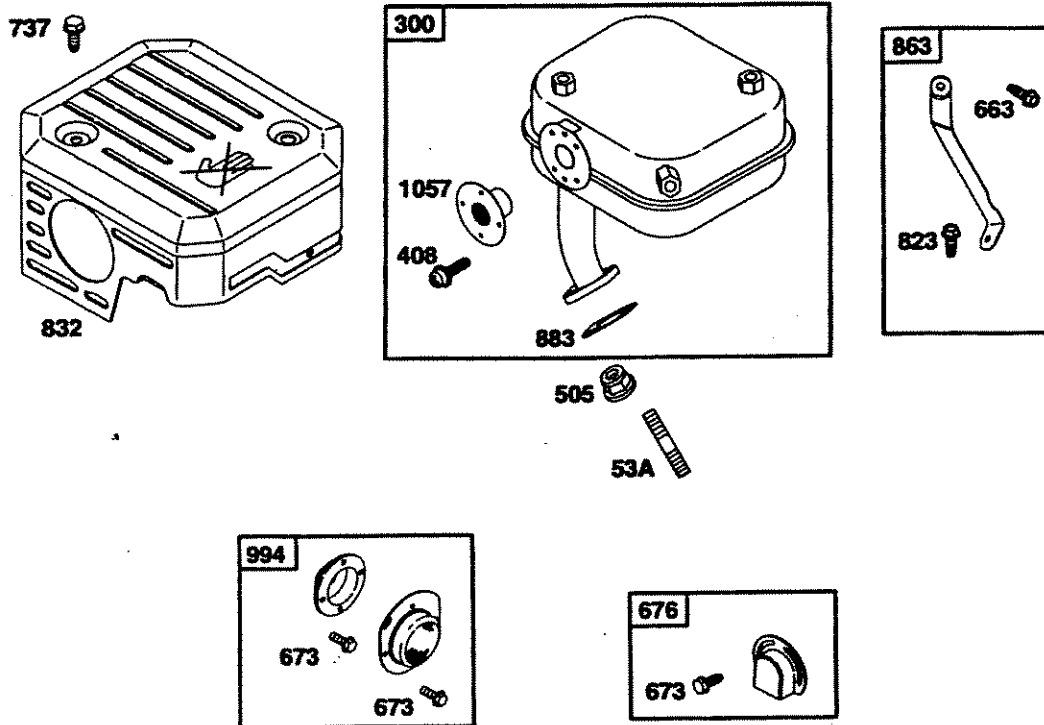

REF. NO.	PART NO.	DESCRIPTION	REF. NO.	PART NO.	DESCRIPTION	REF. NO.	PART NO.	DESCRIPTION
53A	710099	Stud (Muffler Mounting)	663	710057	Screw-Hex	832	710565	Guard-Muffler
300	715508	Muffler-Exhaust	673	93705	Screw-Hex	863	714319	Bracket-Muffler
408	710307	Screw-Phillips	676	715230	Deflector-Muffler	883	★710082	Gasket-Muffler
505	710090	Nut-Lock	737	710074	Screw-Hex	994	715491	Arrester-Spark
			823	710248	Screw-Hex	1075	710329	Screen-Outlet

- Included in Gasket Set-Part No. 715482
- ★ Included in Valve Overhaul Kit-Part No. 715483
- ▲ Included in Carburetor Kit-Part No. 715484
- ✦ Included in Gasket Gasket Set -Part No. 715485

ENGINE PARTS

CRAFTSMAN 2700 PSI HIGH PRESSURE WASHER 919.762700

ENGINE NUMBER 138432-0035-A1

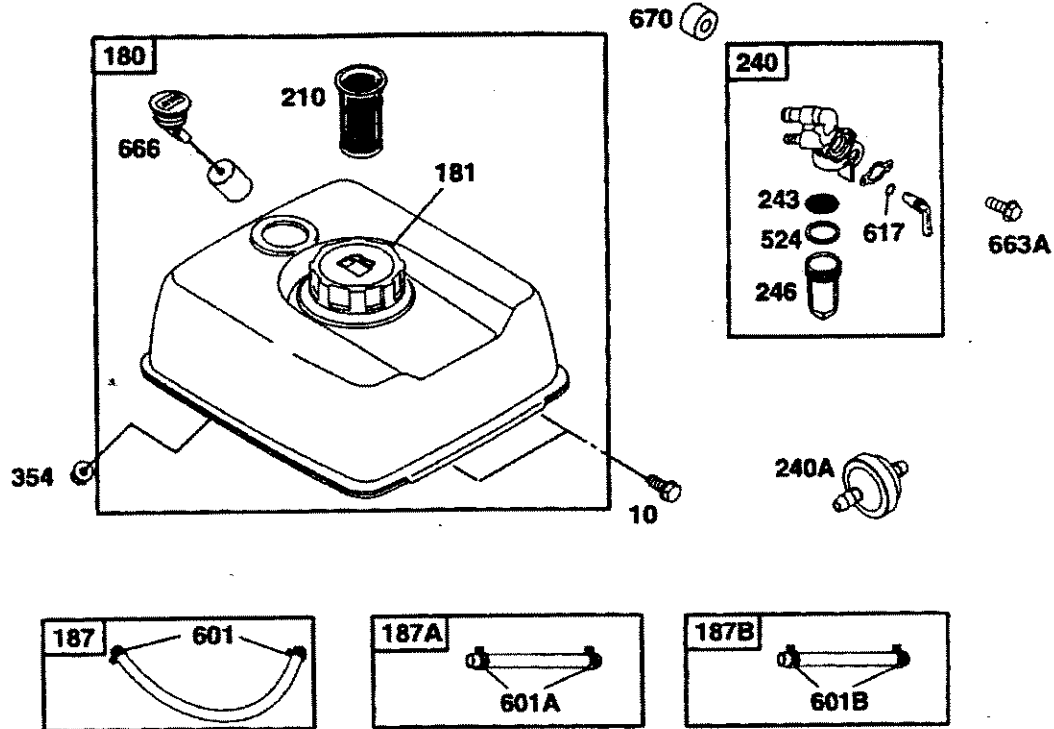

REF. NO.	PART NO.	DESCRIPTION	REF. NO.	PART NO.	DESCRIPTION	REF. NO.	PART NO.	DESCRIPTION
10	710023	Screw-Hex	187B	296004	Line-Fuel (0.25" ID) (Carburetor-To-Filter) (Cut to Required Length)	601B	93053	Clamp-Hose
180	715431	Tank-Fuel	210	710065	Strainer-Fuel	617	710069	Seal-O-Ring
181	710490	Cap-Fuel Tank	240	715027	Filter-Fuel	663A	710160	Screw-Hex
187	715125	Line-Fuel (8mm ID) (Fuel Tank-To-Filter/ Shut-off) (Cut to Required Length)	240A	298090	Filter-Fuel	666	710066	Gauge-Fuel
187A	715126	Line-Fuel (4mm ID) (Filter/Shut-Off-To-Carburetor) (Cut to Required Length)	243	710071	Filter-Fuel	670	710159	Spacer-Fuel Tank
			246	710070	Bowl-Filter			
			354	710068	Nut-Hex			
			524	710072	Seal-O-Ring			
			601	710067	Clamp-Hose			
			601A	710075	Clamp-Hose			

- Included in Gasket Set-Part No. 715482
- ✦ Included in Valve Overhaul Kit-Part No. 715483
- ▲ Included in Carburetor Kit-Part No. 715484
- ✦ Included in Gasket Gasket Set -Part No. 715485

ENGINE PARTS

CRAFTSMAN 2700 PSI HIGH PRESSURE WASHER 919.762700

ENGINE NUMBER 138432-0035-A1

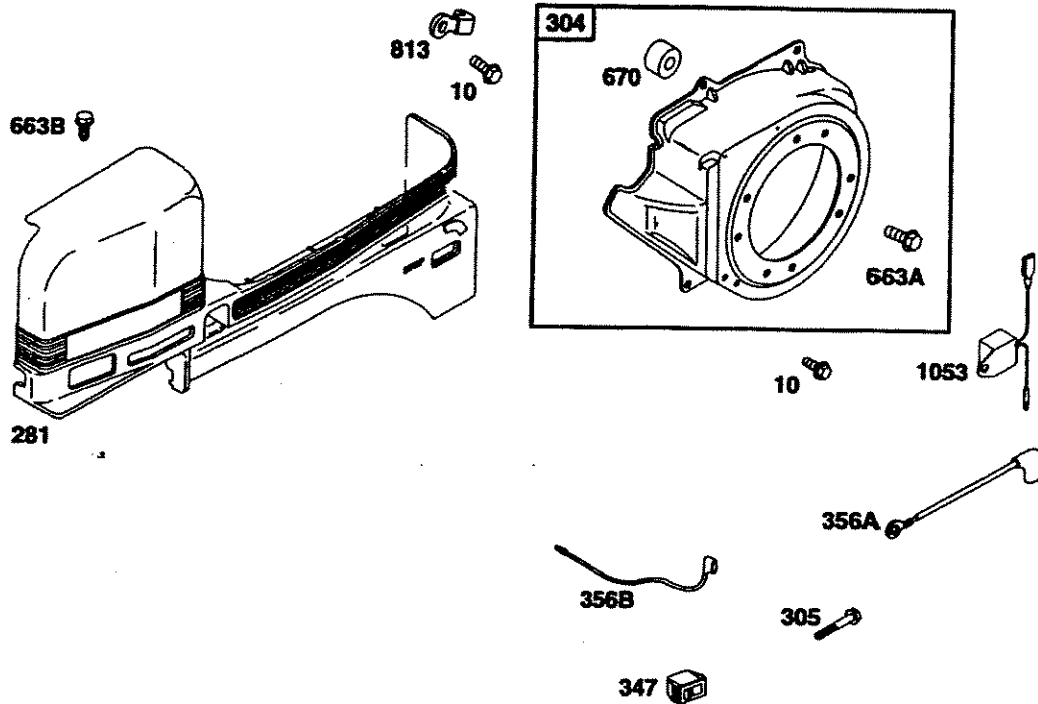

REF. NO.	PART NO.	DESCRIPTION	REF. NO.	PART NO.	DESCRIPTION	REF. NO.	PART NO.	DESCRIPTION
10	710023	Screw-Hex	304	715465	Housing-Blower	356A	710120	Wire-Stop
281	710646	Panel-Control Used on Type No(s). 0035	305	710095	Screw-Hex	356B	710087	Wire-Stop
			347	493521	Switch-Rocker (Without Lamp)	663A	710160	Screw-Hex
						663B	710234	Screw-Hex
						670	710159	Spacer-Fuel Tank
						813	710083	Clamp
						1036	499350	Label Kit-Emission
						1053	710305	Module

- Included in Gasket Set-Part No. 715482
- ★ Included in Valve Overhaul Kit-Part No. 715483
- ▲ Included in Carburetor Kit-Part No. 715484
- ✦ Included in Gasket Gasket Set -Part No. 715485

ENGINE PARTS

CRAFTSMAN 2700 PSI HIGH PRESSURE WASHER 919.762700

ENGINE NUMBER 138432-0035

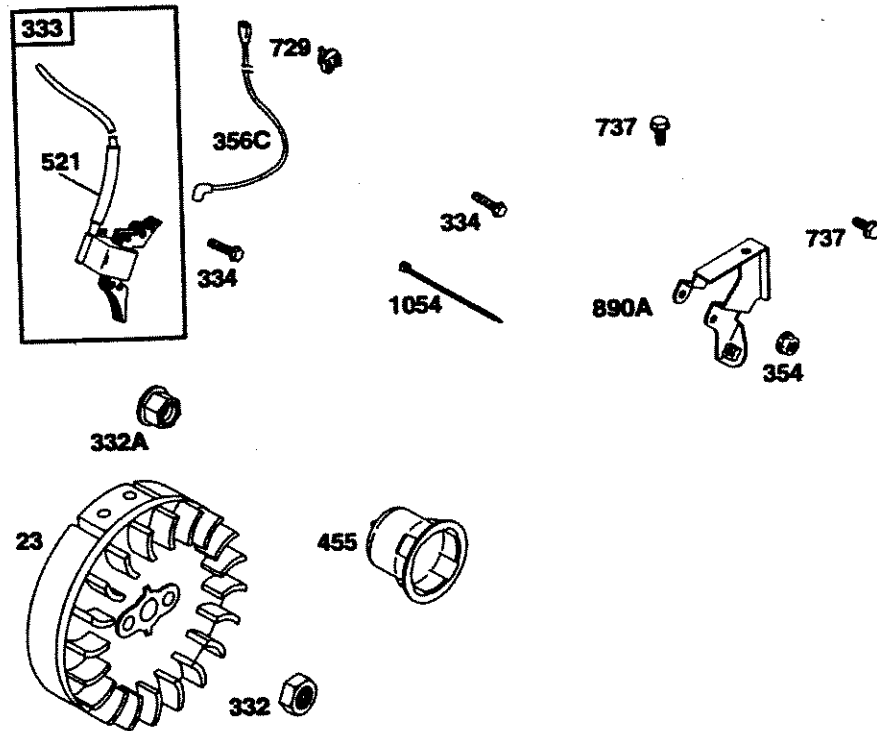

REF. NO.	PART NO.	DESCRIPTION	REF. NO.	PART NO.	DESCRIPTION	REF. NO.	PART NO.	DESCRIPTION
23	715429	Flywheel	334	710047	Screw-Hex	890A	710644	Bracket-Support
120	93836	Washer-Lock	354	710068	Nut-Hex	892	493625	Key Switch (Includes Keys)
154	93837	Nut-Hex	356C	710324	Wire-Ground	990	392832	Key Set-Starter Switch
281A	710658	Panel-Control	455	710277	Cup-Flywheel	1054	710349	Tie-Cable
332	710048	Nut-Hex	475	715200	Rectifier			
332A	710345	Nut-Hex	521	710045	Shielding-Cable			
333	715464	Armature-Magneto	526	710089	Srew-Hex			
			729	710046	Clip-Wire			
			737	710074	Screw-Hex			

- Included in Gasket Set-Part No. 715482
- ★ Included in Valve Overhaul Kit-Part No. 715483
- ▲ Included in Carburetor Kit-Part No. 715484
- ✦ Included in Gasket Gasket Set -Part No. 715485

ENGINE PARTS

CRAFTSMAN 2700 PSI HIGH PRESSURE WASHER 919.762700

ENGINE NUMBER 138432-0035-A1

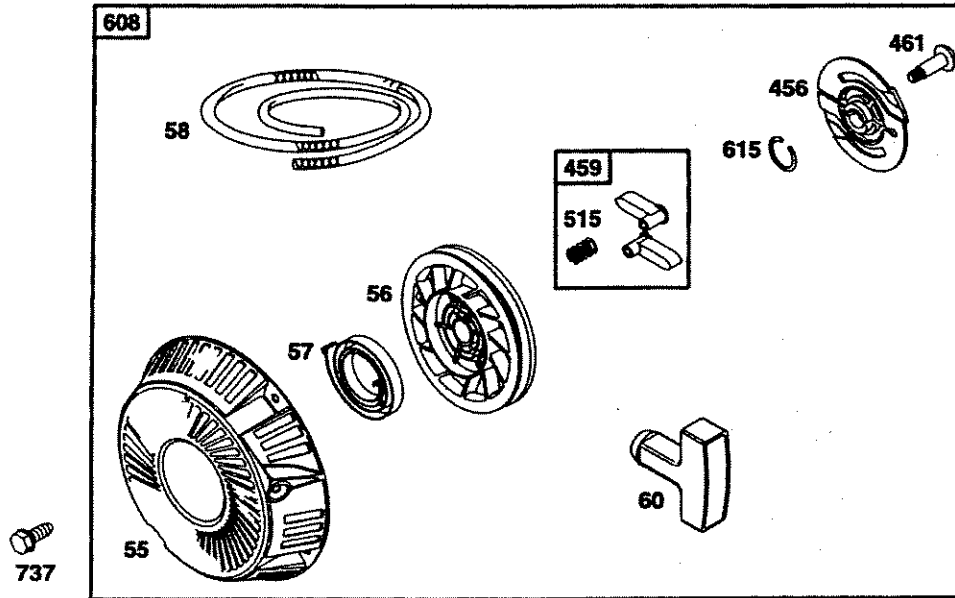

REF. NO.	PART NO.	DESCRIPTION	REF. NO.	PART NO.	DESCRIPTION	REF. NO.	PART NO.	DESCRIPTION
55	715132	Housing-Rewind Starter	58	710275	Rope-Starter (Cut to Required Length)	461	805955	Screw-Shoulder
56	710274	Pulley-Starter	60	490652	Grip-Starter Rope	515	805953	Spring-Pawl
57	710270	Spring-Rewind Starter	456	710272	Plate-Pawl Friction	608	715133	Starter-Rewind
			459	715256	Pawl-Ratchet	615	805952	Ring-Rewind Starter
						737	710074	Screw-Hex

- Included in Gasket Set-Part No. 715482
- ★ Included in Valve Overhaul Kit-Part No. 715483
- ▲ Included in Carburetor Kit-Part No. 715484
- ✦ Included in Gasket Gasket Set -Part No. 715485

ENGINE PARTS

CRAFTSMAN 2700 PSI HIGH PRESSURE WASHER 919.762700

ENGINE NUMBER 138432-003

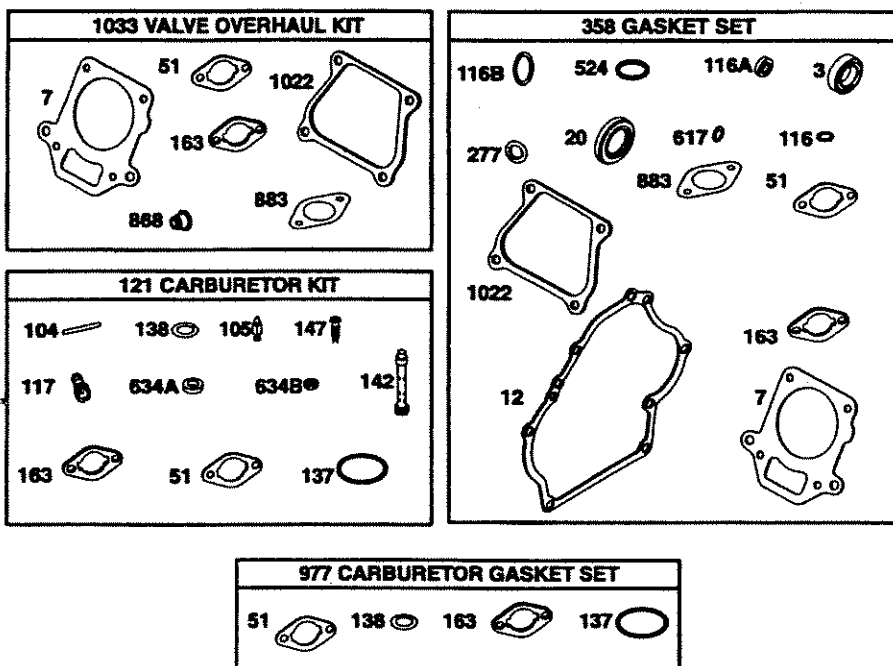

REF. NO.	PART NO.	DESCRIPTION	REF. NO.	PART NO.	DESCRIPTION	REF. NO.	PART NO.	DESCRIPTION
3	● 710000	Seal-Oil	121	715484	Carburetor Kit	617	★ 710069	Seal-O-Ring
7	●★ 710624	Gasket-Cylinder Head	137	▲◆	Gasket-Float Bowl (Sold in Kit Only)	634A	●	Seal-Throttle Shaft (Sold in Kit Only)
12	● 710628	Gasket-Crankcase	138	▲◆	Washer (Sold in Kit Only)	634B	●	Bushing-Choke Shaft (Sold in Kit Only)
20	● 710215	Seal-Oil	142	▲ 710664	Nozzle-Carburetor	868	★ 710019	Seal-Valve
51	●★▲ 710060	Gasket-Intake	147	▲ 710675	Jet-Pilot	883	●★ 710082	Gasket-Exhaust
104	▲ 710663	Pin-Float	163	●★▲◆ 710639	Gasket-Air Cleaner	977	715485	Gasket Set-Carburetor
105	▲ 710661	Valve-Needle	277	● 710004	Washer-Seal	1022	●★ 710262	Gasket-Rocker Cover
116	● 710055	Seal-Oil	358	715482	Gasket Set	1033	715483	Kit-Valve Overhaul
116A	● 710091	Seal-O-Ring	524	● 710072	Seal-O-Ring			
116B	● 710029	Seal-O-Ring						
117	▲ 710665	Jet-Main						

- Included in Gasket Set-Part No. 715482
- ★ Included in Valve Overhaul Kit-Part No. 715483
- ▲ Included in Carburetor Kit-Part No. 715484
- ◆ Included in Gasket Gasket Set -Part No. 715485

**Briggs & Stratton Corporation (B&S), the California Air Resources Board (CARB)
and the United States Environmental Protection Agency (U.S. EPA)**

Emission Control System Warranty Statement (Owner's Defect Warranty Rights and Obligations)

In the interest of the environment, B&S engines that meet strict emission requirements are labeled, "This engine conforms to 1995 - 1998 California emission regulations for ULGE engines and U.S. EPA Phase I regulations for small non-road engines."

EMISSION CONTROL WARRANTY COVERAGE IS APPLICABLE

California and United States Emission Control Defects Warranty Statement

CARB, U.S. EPA and B&S are pleased to explain the Emission Control System Warranty on your 1996 and later utility or lawn and garden equipment (ULGE) engine. In California, new ULGE engines produced on or after August 1, 1995 must be designed, built and equipped to meet the State's stringent anti-smog standards. Elsewhere in the United States, new non-road, spark-ignition engines certified for model year 1997 and later, must meet similar standards set forth by the U.S. EPA. B&S must warrant the emission control system on your engine for the periods of time listed below, provided

TO CERTIFIED ENGINES PURCHASED IN CALIFORNIA IN 1995 AND THEREAFTER, WHICH ARE USED IN CALIFORNIA, AND TO CERTIFIED MODEL YEAR 1997 AND LATER ENGINES WHICH ARE PURCHASED AND USED ELSEWHERE IN THE UNITED STATES.

there has been no abuse, neglect or improper maintenance of your ULGE engine.

Your emission control system includes parts such as the carburetor, air cleaner, ignition system, muffler and catalytic converter. Also included may be connectors and other emission related assemblies.

Where a warrantable condition exists, B&S will repair your ULGE engine at no cost to you including diagnosis, parts and labor.

Briggs & Stratton Emission Control Defects Warranty Coverage

ULGE engines are warranted relative to emission control parts defects for a period of two years, subject to provisions set forth

below. If any covered part on your engine is defective, the part will be repaired or replaced by B&S.

Owner's Warranty Responsibilities

As the ULGE engine owner, you are responsible for the performance of the required maintenance listed in your Operator/Owner Manual. B&S recommends that you retain all your receipts covering maintenance on your ULGE engine, but B&S cannot deny warranty solely for the lack of receipts or for your failure to ensure the performance of all scheduled maintenance.

You are responsible for presenting your ULGE engine to an Authorized B&S Service Dealer as soon as a problem exists. The undisputed warranty repairs should be completed in a reasonable amount of time, not to exceed 30 days.

If you have any questions regarding your warranty rights and responsibilities, you should contact a B&S Service Representative at 1-414-259-5262.

The emission warranty is a defects warranty. Defects are judged on normal engine performance. The warranty is not related to an in-use emission test.

As the ULGE engine owner, you should however be aware that B&S may deny you warranty coverage if your ULGE engine or a part has failed due to abuse, neglect, improper maintenance or unapproved modifications.

Briggs & Stratton Emission Control Defects Warranty Provisions

The following are specific provisions relative to your Emission Control Defects Warranty Coverage. It is in addition to the B&S engine warranty on non-regulated engines found in the Operator/Owner Manual.

Warranted Parts

Coverage under this warranty extends only to the parts listed below (the emission control systems parts) to the extent these parts were present on the engine purchased.

- a. Fuel Metering System
 - Cold start enrichment system (soft choke)
 - Carburetor and internal parts
 - Fuel Pump
- b. Air Induction System
 - Air cleaner
 - Intake manifold
- c. Ignition System
 - Spark plug(s)
 - Magneto ignition system
- d. Catalyst System
 - Catalytic converter
 - Exhaust manifold
 - Air injection system or pulse valve
- e. Miscellaneous Items Used in Above Systems
 - Vacuum, temperature, position, time sensitive valves and switches
 - Connectors and assemblies

2. Length of Coverage

B&S warrants to the initial owner and each subsequent purchaser that the Warranted Parts shall be free from defects in materials and workmanship which caused the failure of the Warranted Parts for a period of two years from the date the engine is delivered to a retail purchaser.

3. No Charge

Repair or replacement of any Warranted Part will be performed at no charge to the owner, including diagnostic labor which leads to the determination that a Warranted Part is defective, if the diagnostic work is performed at an Authorized B&S Service Dealer. For emissions warranty service contact your nearest Authorized B&S Service Dealer as listed in the "Yellow Pages" under "Engines, Gasoline," "Gasoline Engines," "Lawn Mowers," or similar category.

4. Claims and Coverage Exclusions

Warranty claims shall be filed in accordance with the provisions of the B&S Engine Warranty Policy. Warranty coverage shall be excluded for failures of Warranted Parts which are not original B&S parts or because of abuse, neglect or improper maintenance as set forth in the B&S Engine Warranty Policy. B&S is not liable to cover failures of Warranted Parts caused by the use of add-on, non-original, or modified parts.

5. Maintenance

Any Warranted Part which is not scheduled for replacement as required maintenance or which is scheduled only for regular inspection to the effect of "repair or replace as necessary" shall be warranted as to defects for the warranty period. Any Warranted Part which is scheduled for replacement as required maintenance shall be warranted as to defects only for the period of time up to the first scheduled replacement for that part. Any replacement part that is equivalent in performance and durability may be used in the performance of any maintenance or repairs. The owner is responsible for the performance of all required maintenance, as defined in the B&S Operator/Owner Manual.

6. Consequential Coverage

Coverage hereunder shall extend to the failure of any engine components caused by the failure of any Warranted Part still under warranty.

Briggs & Stratton welcomes warranty repair and apologizes to you for being inconvenienced. Any Authorized Service Dealer may perform warranty repairs. Most warranty repairs are handled routinely, but sometimes requests for warranty service may not be appropriate. For example, warranty would not apply if engine damage occurred because of misuse, lack of routine maintenance, shipping, handling, warehousing or improper installation. Similarly, warranty is void if the serial number of the engine has been removed or the engine has been altered or modified.

If a customer differs with the decision of the Service-Dealer, an investigation will be made to determine whether the warranty applies. Ask the Service Dealer to submit all supporting facts to his Distributor or the Factory for review. If the Distributor or the Factory decides that the claim is justified, the customer will be fully reimbursed for those items that are defective. To avoid misunderstanding which might occur between the customer and the Dealer, listed below are some of the causes of engine failure that the warranty does not cover.

Improper maintenance:

The life of an engine depends upon the conditions under which it operates, and the care it receives. Some applications, such as tillers, pumps and rotary mowers, are very often used in dusty or dirty conditions, which can cause what appears to be premature wear. Such wear, when caused by dirt, dust, spark plug cleaning grit, or other abrasive material that has entered the engine because of improper maintenance, is not covered by warranty.

This warranty covers engine related defective material and/or workmanship only, and not replacement or refund of the equipment to which the engine may be mounted. Nor does the warranty extend to repairs required because of:

1. PROBLEMS CAUSED BY PARTS THAT ARE NOT ORIGINAL BRIGGS & STRATTON PARTS.
2. Equipment controls or installations that prevent starting, cause unsatisfactory engine performance, or shorten engine life. (Contact equipment manufacturer.)
3. Leaking carburetors, clogged fuel pipes, sticking valves, or other damage, caused by using contaminated or stale fuel. (Use clean, fresh, lead-free gasoline and Briggs & Stratton gasoline stabilizer, Part No. 5041.)
4. Parts which are scored or broken because an engine was operated with insufficient or contaminated lubricating oil, or an incorrect grade of lubricating oil (check oil level daily or after every 8 hours of operation. Refill when necessary and change at recommended intervals.) Read "Owner's Manual."
5. Repair or adjustment of associated parts or assemblies such as clutches, transmissions, remote controls, etc., which are not manufactured by Briggs & Stratton.
6. Damage or wear to parts caused by dirt, which entered the engine because of improper air cleaner maintenance, re-assembly, or use of a non-original air cleaner element or cartridge. (At recommended intervals, clean and re-oil the Oil-Foam® element or the foam pre-cleaner, and replace the cartridge.) Read "Owner's Manual."
7. Parts damaged by overspeeding, or overheating caused by grass, debris, or dirt, which plugs or clogs the cooling fins, or flywheel area, or damage caused by operating the engine in a confined area without sufficient ventilation. (Clean fins on the cylinder, cylinder head and flywheel at recommended intervals.) Read "Owner's Manual."
8. Engine or equipment parts broken by excessive vibration caused by a loose engine mounting, loose cutter blades, unbalanced blades or loose or unbalanced impellers, improper attachment of equipment to engine crankshaft, overspeeding or other abuse in operation.
9. A bent or broken crankshaft, caused by striking a solid object with the cutter blade of a rotary lawn mower, or excessive v-belt tightness.
10. Routine tune-up or adjustment of the engine.
11. Engine or engine component failure, i.e., combustion chamber, valves, valve seats, valve guides, or burned starter motor windings, caused by the use of alternate fuels such as, liquified petroleum, natural gas, altered gasolines, etc.

For the repair or replacement parts you need

Call 7 am - 7 pm, 7 days a week

1-800-366-PART

(1-800-366-7278)



For in-home major brand repair service

Call 24 hours a day, 7 days a week

1-800-4-REPAIR

(1-800-473-7247)



**For the location of a
Sears Parts and Repair Center in your area**

Call 24 hours a day, 7 days a week

1-800-488-1222



**For information on purchasing a Sears
Maintenance Agreement or to inquire
about an existing Agreement
call 9 am - 5 pm, Monday-Saturday**

1-800-827-6655



SEARS

REPAIR SERVICES

America's Repair Specialists

Sears, Roebuck and Co., Hoffman Estates, IL 60179 U.S.A.



Free Manuals Download Website

<http://myh66.com>

<http://usermanuals.us>

<http://www.somanuals.com>

<http://www.4manuals.cc>

<http://www.manual-lib.com>

<http://www.404manual.com>

<http://www.luxmanual.com>

<http://aubethermostatmanual.com>

Golf course search by state

<http://golfingnear.com>

Email search by domain

<http://emailbydomain.com>

Auto manuals search

<http://auto.somanuals.com>

TV manuals search

<http://tv.somanuals.com>