

OWNER'S MANUAL

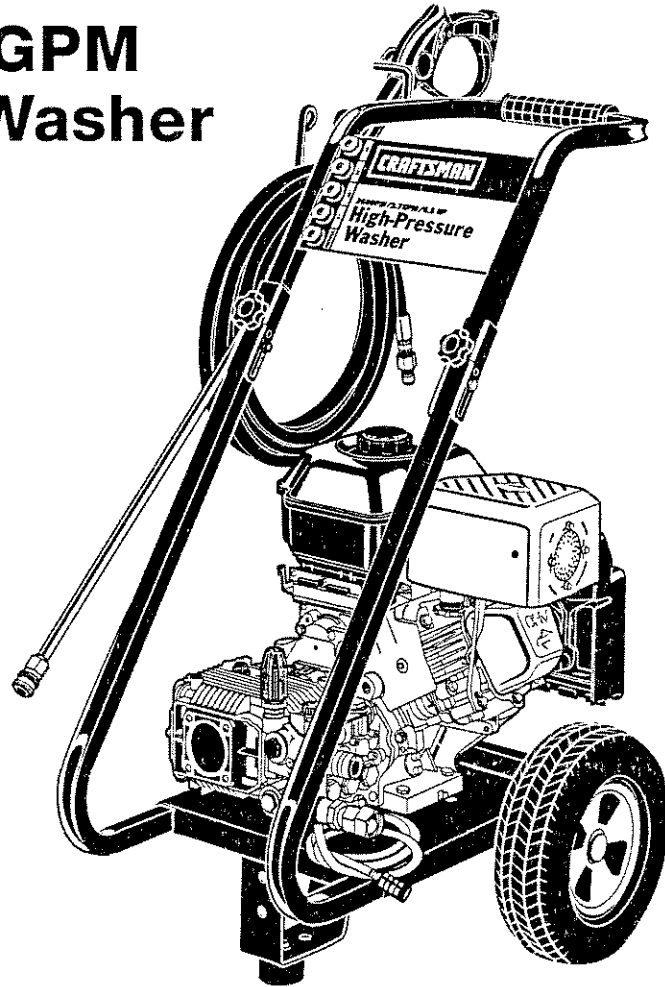

6.5 Horsepower 2600 PSI 2.7 GPM High Pressure Washer

Model No:
919.769020



WARNING: Before using this product, read this manual and follow all Safety Rules and Operating Instructions.



- Safety
- Assembly
- Operation
- Maintenance
- Parts List
- Español

Sears, Roebuck and Co., Hoffman Estates, IL 60179 U.S.A.

TABLE OF CONTENTS

Warranty	2	Storage	15
Safety Guidelines	3-5	Troubleshooting	16
Assembly	5-7	Parts.....	17-28
Operation	7-11	EPA Codes	29-30
Maintenance	12-14	Español	31-51
Service and Adjustments.....	15	How to Order Parts	Back Cover

FULL ONE YEAR WARRANTY ON CRAFTSMAN HIGH PRESSURE WASHER

For one year from the date of purchase, when this Craftsman High Pressure Washer is maintained and operated according to the instructions in the owner's manual, Sears will repair, free of charge, any defect in material and workmanship.

If your Craftsman Pressure Washer is used for commercial or rental purposes, this warranty applies only for 90 days from the date of purchase. If this washer is used for rented purposes this warranty applies for only 30 days from the date of purchase.

FULL TWO YEAR WARRANTY ON CRAFTSMAN ENGINE

For two years from the date of purchase, when this Craftsman engine is maintained and operated according to the instructions in the owner's manual, Sears will repair, free of charge, any defect in material and workmanship.

If your Craftsman engine is used for commercial or rental purposes, this warranty applies only for one year from the date of purchase. This warranty does not cover expendable items such as spark plugs and air filters, which become worn during normal use.

Repairs necessary because of operator abuse or negligence, including damage resulting from no water being supplied to pump or failure to maintain the equipment according to the instructions contained in the owner's manual, are not covered under warranty.

WARRANTY SERVICE IS AVAILABLE BY RETURNING THE HIGH PRESSURE WASHER TO THE NEAREST SEARS SERVICE CENTER THROUGHOUT THE UNITED STATES. This warranty gives you specific legal rights and you may also have other rights, which vary from state to state.

Sears, Roebuck and Co., D/817 WA, Hoffman Estates, IL 60179

SAFETY GUIDELINES - DEFINITIONS

This manual contains information that is important for you to know and understand. This information relates to protecting **YOUR SAFETY** and **PREVENTING EQUIPMENT PROBLEMS**. To help you recognize this information, we use the symbols below. Please read the manual and pay attention to these sections. **SAVE THESE DEFINITIONS/INSTRUCTIONS.**

▲ WARNING indicates a potentially hazardous situation which, if not avoided, **could** result in **death or serious injury**.

▲ DANGER indicates an imminently hazardous situation which, if not avoided, **will** result in **death or serious injury**.



▲ CAUTION indicates a potentially hazardous situation which, if not avoided, **may** result in **minor or moderate injury**.

10/2/97





IMPORTANT SAFETY INSTRUCTIONS

▲ WARNING

Improper operation or maintenance of this product could result in serious injury and property damage. Read and understand all warnings and operating instructions before using.

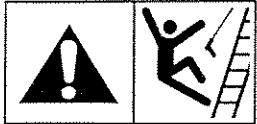
HAZARD	WHAT CAN HAPPEN	HOW TO PREVENT IT
<p style="text-align: center;">▲ DANGER</p> <p style="text-align: center;">RISK OF EXPLOSION OR FIRE</p> <div style="text-align: center;">  </div>	<ul style="list-style-type: none"> • Spilled gasoline and its vapors can become ignited from cigarette sparks, electrical arcing, exhaust gases, and hot engine components such as the muffler. • Heat will expand fuel in the tank which could result in spillage and possible fire explosion. • Operating the pressure washer in an explosive environment could result in a fire. • Materials placed against or near the pressure washer can interfere with its proper ventilation features causing overheating and possible ignition of the materials. • Improperly stored fuel could lead to accidental ignition. Fuel improperly secured could get into the hands of children or other unqualified persons. 	<ul style="list-style-type: none"> • Shut off engine and allow it to cool before adding fuel to the tank. • Use care in filling tank to avoid spilling fuel. Move pressure washer away from fueling area before starting engine. • Keep maximum fuel level ½" below top of tank to allow for expansion. • Operate and fuel equipment in well ventilated areas free from obstructions. Equip areas with fire extinguishers suitable for gasoline fires. • Never operate pressure washer in an area containing dry brush or weeds. • Store fuel in container approved for gasoline, in a secure location away from work area.
<p style="text-align: center;">▲ DANGER</p> <p style="text-align: center;">RISK TO BREATHING</p> <div style="text-align: center;">  </div>	<ul style="list-style-type: none"> • Breathing exhaust fumes will cause serious injury or death. • Some cleaning fluids contain substances which could cause injury to skin, eyes, or lungs. 	<ul style="list-style-type: none"> • Operate pressure washer in a well ventilated area. Avoid enclosed areas such as garages, basements, etc. • Never operate unit in a location occupied by humans or animals. • Use only cleaning fluids specifically recommended for high pressure washers. Follow manufacturers recommendations.

IMPORTANT SAFETY INSTRUCTIONS (cont'd)

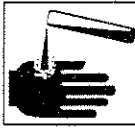
HAZARD	WHAT CAN HAPPEN	HOW TO PREVENT IT
<p>⚠ WARNING RISK OF UNSAFE OPERATION</p> 	<ul style="list-style-type: none"> • Unsafe operation of your pressure washer could lead to serious injury or death to you or others. • The spray gun/wand is a powerful cleaning tool that could look like a toy to a child. • Reactive force of spray will cause gun/wand to move, and could cause the operator to slip or fall, or misdirect the spray. Improper control of gun/wand can result in injuries to self and others. 	<ul style="list-style-type: none"> • Become familiar with the operation and controls of the pressure washer. • Keep children away from the pressure washer at all times. • Never defeat the safety features of this product. • Do not operate machine with missing, broken, or unauthorized parts. • Never leave wand unattended while unit is running. • Keep work area free of obstacles. • Stand on a stable surface and grip gun/wand firmly. Expect the gun to kick when triggered.
<p>⚠ WARNING RISK OF INJURY FROM SPRAY</p> 	<ul style="list-style-type: none"> • High velocity fluid spray can cause objects to break, propelling particles at high speed. • Light or unsecured objects can become hazardous projectiles. 	<ul style="list-style-type: none"> • Always wear ANSI approved Z87 safety glasses. Wear protective clothing to protect against accidental spraying. • Never point wand at, or spray people or animals. • Always secure trigger lock when wand is not in service to prevent accidental operation. • Never permanently secure trigger in pull back (open) position.
<p>⚠ WARNING RISK OF ELECTRICAL SHOCK</p> 	<ul style="list-style-type: none"> • Spray directed at electrical outlets or switches, or objects connected to an electrical circuit, could result in a fatal electrical shock. 	<ul style="list-style-type: none"> • Unplug any electrically operated product before attempting to clean it. Direct spray away from electric outlets and switches.
<p>⚠ WARNING RISK OF FLUID INJECTION</p> 	<ul style="list-style-type: none"> • Your washer operates at fluid pressures and velocities high enough to penetrate human and animal flesh, which could result in amputation or other serious injury. Leaks caused by loose fittings or worn or damaged hoses can result in injection injuries. DO NOT TREAT FLUID INJECTION AS A SIMPLE CUT! See a physician immediately! • Relieve system pressure before attempting maintenance or disassembly of equipment. 	<ul style="list-style-type: none"> • Never place hands in front of nozzle. • Direct spray away from self and others. • Make sure hose and fittings are tightened and in good condition. Never hold onto the hose or fittings during operation. • Do not allow hose to contact muffler. • Never attach or remove wand or hose fittings while system is pressurized. • Use only hose and high pressure accessories rated for 2600 PSI service. • To relieve system pressure, shut off engine, turn off water supply, and pull gun trigger until water stops flowing.
<p>⚠ WARNING RISK OF CHEMICAL BURN</p> 	<ul style="list-style-type: none"> • Use of acids, toxic or corrosive chemicals, poisons, insecticides, or any kind of flammable solvent with this product could result in serious injury or death. 	<ul style="list-style-type: none"> • Do not use acids, gasoline, kerosene, or any other flammable materials in this product. Use only household detergents, cleaners and degreasers recommended for use in pressure washers. • Wear protective clothing to protect eyes and skin from contact with sprayed materials.

IMPORTANT SAFETY INSTRUCTIONS (cont'd)

HAZARD	WHAT CAN HAPPEN	HOW TO PREVENT IT
<p>⚠ WARNING RISK OF HOT SURFACES</p> 	<ul style="list-style-type: none"> Contact with hot surfaces, such as engines exhaust components, could result in serious burn. 	<ul style="list-style-type: none"> During operation, touch only the control surfaces of the pressure washer. Keep children away from the pressure washer at all times. They may not be able to recognize the hazards of this product.

International Symbols



Safety Alert - Read Owner's Manual

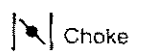

⚠ CAUTION

The powerful spray from your pressure washer is capable of causing damage to fragile surfaces such as: wood, glass, automobile paint, auto stripping and trim, and delicate objects such as flowers and shrubs. Before spraying, check the item to be cleaned to assure yourself that it is robust enough to resist damage from the force of the spray. Avoid the use of the concentrated spray stream except for very strong surfaces like concrete and steel.

Operating unit with water supply shut off without flow of water will result in equipment damage. You should never run this pressure washer for more than 2 minutes without pulling the trigger to allow cool water to enter the pump and the heated (recirculated) water to exit. Running the pressure washer with water supply shut off will void your warranty.

ASSEMBLY

Carton Contents

- Main Unit pressure washer with wheels
- Handle
- High Pressure Hose
- Chemical Pickup Hose and Filter
- Quick Connects (5 included)
- Gun
- Wand



Main Unit pressure washer with wheels

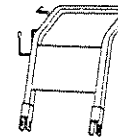

Handle



High Pressure Hose



Chemical Pickup Hose and Filter



Quick Connects Nozzles

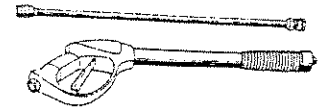

Gun and Wand

• Bag Containing

- Video Cassette
- Owners' Manual
- Nozzle Cleaning Kit and Replacement O-Rings
- Engine Oil
- Rubber Isolator and Mounting Hardware
- Handle Mounting Hardware



Video Cassette



Owners' Manual

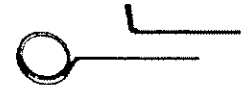

Nozzle Cleaning Kit



Handle Mounting Hardware



Engine Oil

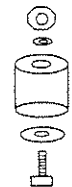

Rubber Isolator and Mounting Hardware

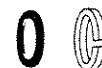

Replacement O-Rings

Tools Required for Assembly

Adjustable wrench

1/2" Socket

Remove Pressure Washer from Carton

- Open carton from the top. Locate and remove from carton, the parts box, which includes gun, handle, wand, oil, knobs and bolts. Next remove the parts bag and the handle.
- Cut carton along dotted lines.
- Remove all carton inserts.
- Roll unit through opening in carton.

Note: The pressure and chemical hose are located at the bottom of the box.

Preparing the Pressure Washer for First Use

Note: Included with your pressure washer is a video tape on how to prepare your unit for operation. It is recommended you view this tape before performing the next steps.

1. Insert handle onto frame.
 - Insert knobs into the threaded slot in front of the frame handle and tighten by turning in a clockwise direction.
 - Slide bolts into the slot in the side of the frame handle and tighten the nut by turning in a clockwise direction.

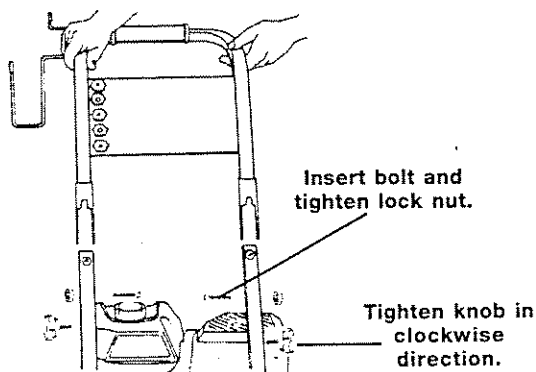

2. Remove wood plank from the frame of the unit. An adjustable wrench is required. Discard bolt and board.

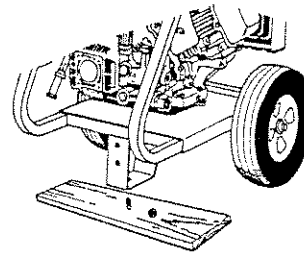

3. Mount the rubber isolator to the frame.

- To mount isolator place threaded end of bolt through the washer.
- Next with washer on bolt place threaded end of bolt through larger hole in bottom of the rubber isolator. Place threaded portion of isolator through the front hole location where the wood plank was mounted on the pressure washer.
- Next place lockwasher over threaded portion of bolt that has been placed through the mounting hole in the pressure washer and use nut to tighten isolator to the frame.
- Tighten nut with an adjustable wrench.

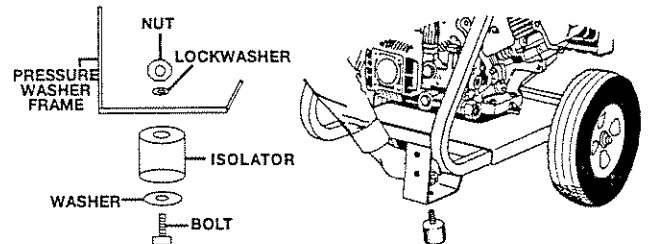

4. Connect wand with nozzle assembly to gun. To tighten, turn knob in clockwise direction. Hand tighten.

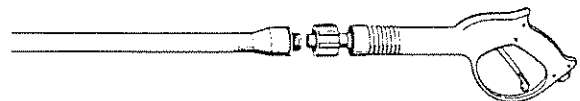

5. Cut tie wrap off of high pressure hose. Unwind high pressure hose to attach the threaded end to the gun. Tighten with adjustable wrench.

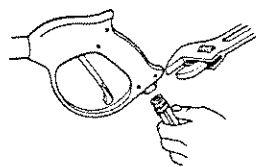

6. Connect chemical hose to the chemical injector hose barb on pump.

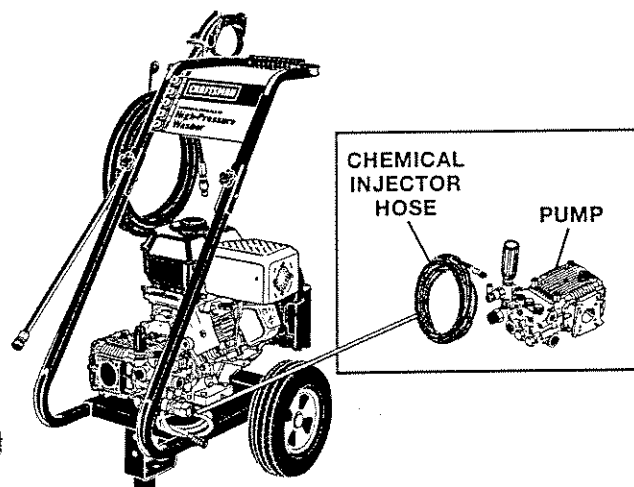

7. Connect high pressure hose to the quick connect outlet on pressure washer.

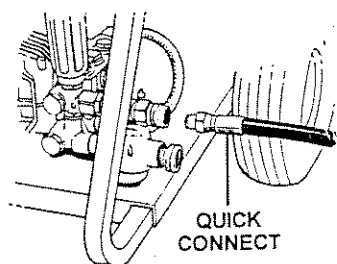

NOTE: Always keep hose away from engine muffler.

8. Your units pump is shipped with a temporary plug that must be replaced with a breather cap. This plug is located over the pump's oil port. Unscrew and remove this plug. Remove the breather cap from the bag attached to the plug and install it in the pump's oil port.

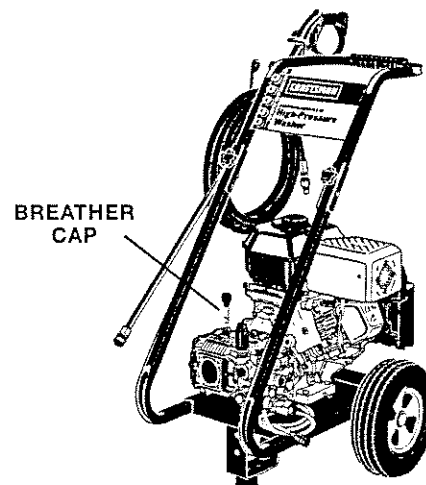

CAUTION: Failure to replace the plug will result in serious pump damage.

9. Place assembled gun and wand on pressure handle bracket as shown.

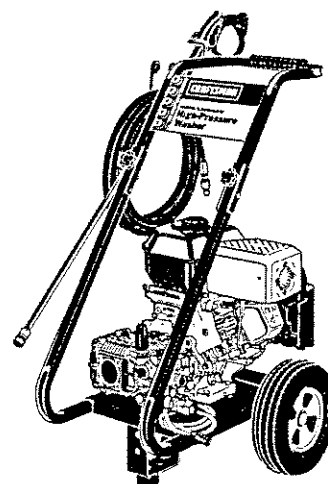

Checklist

Before going any further please review the following:

- Be sure you have completed assembly instruction.
- Double check all fittings to be sure they are tight.

IMPORTANT: Before any attempt to start your pressure washer be sure to check engine oil (See Operation under Engine Oil, page 9.)

OPERATION

Know Your High Pressure Washer

Read this Owner's Manual and Safety Rules before operation of your High Pressure Washer Compare this illustration with our pressure washer to familiarize yourself with the location of various controls and adjustments. Save this manual for future reference.

PUMP- Develops high pressure.

ENGINE OIL FILL- Place where engine oil is poured.

PRESSURE REGULATOR- Allows you to adjust the pressure of the outlet stream.

ENGINE RUN/STOP SWITCH- Sets engine in starting mode for recoil starter — **Stops** running engine.

RECOIL STARTER- Used for starting the engine manually.

SPRAY GUN ASSEMBLY (Contains Gun and Wand)- Controls the application of water onto cleaning surface with trigger device.

PUMP OIL FILL- Port where pump oil is poured and breather cap is located.

GAS TANK/CAP- Cap is removed and unleaded gasoline is poured.

CHEMICAL INJECTION TUBE AND FILTER- Mixes water and detergent in outlet water flow.

HIGH PRESSURE OUTLET- Connection for high pressure hose.

CHOKE- Lever used for starting unit.

QUICK CONNECT NOZZLES- Tips used for various degrees of spray patterns.

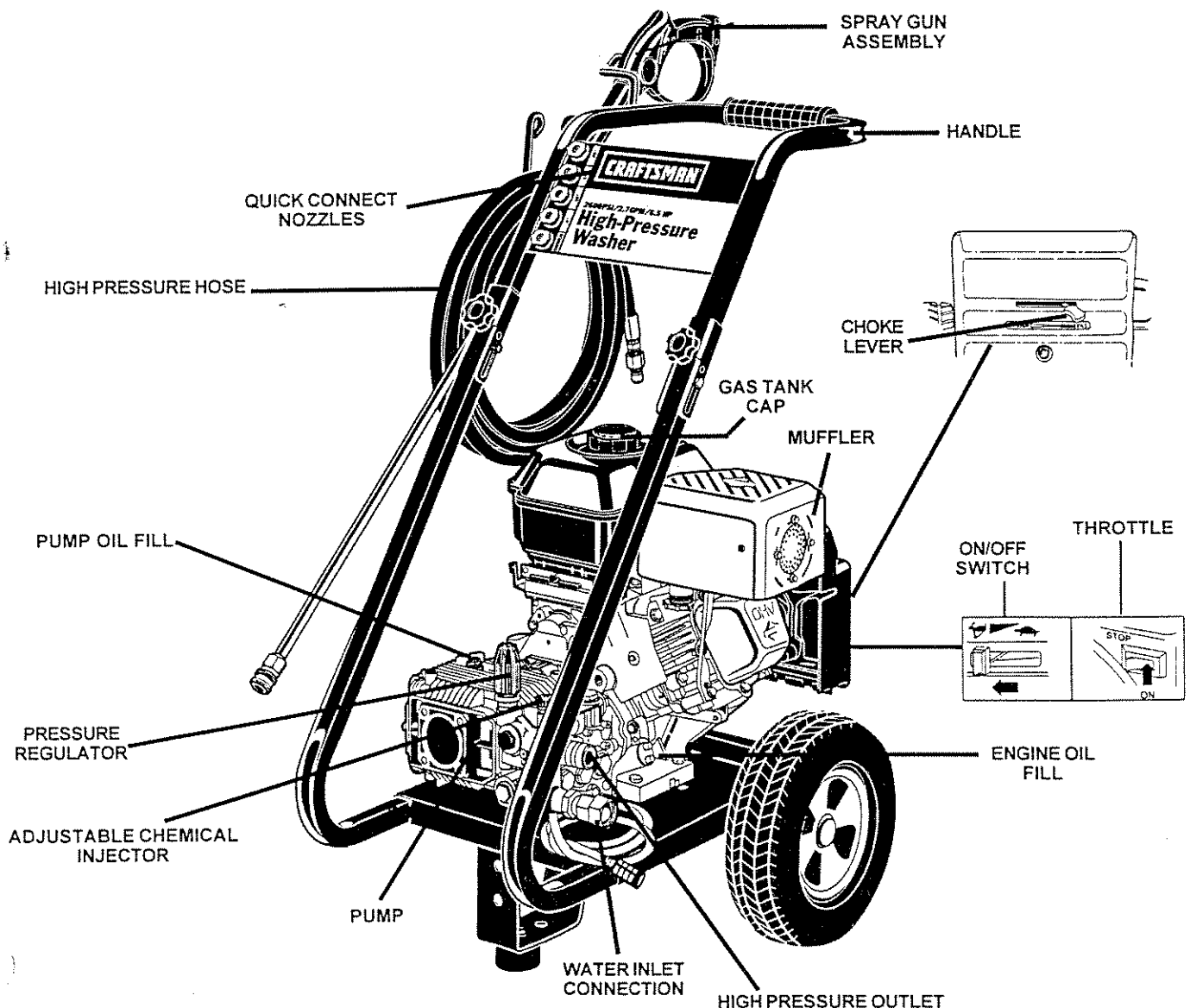

Stopping Your Pressure Washer

▲ CAUTION: Do not run pump without the water supply connected and turned on. Failure to do so will result in pump damage.

- To turn pressure washer off place the on/stop switch to the stop position.

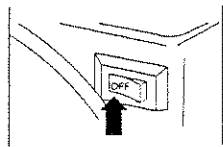

- Simply shutting OFF engine will not release pressure in the system. Squeeze the trigger on the spray gun for about 3 seconds to relieve pressure. Spray stream will decrease in length.

IMPORTANT: This unit is equipped with a thermal relief valve. If unit is allowed to run for several minutes without pressing the trigger on the spray gun, several drops of water may be released through this valve to cool the unit. The heated water will be purged from the bottom of the pump.

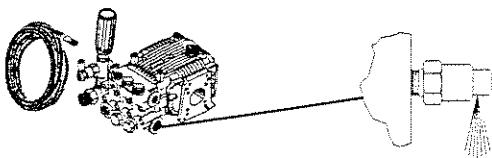

BEFORE STARTING THE ENGINE

To operate the engine you will need to do the following.

▲ CAUTION: Always check engine oil level before every start. Running engine low on oil or out of oil could result in serious damage.

▲ CAUTION: Always check pump oil level before every start. Running pump low on oil could result in pump damage.

Adding Pump Oil

Before running the high pressure washer, check the pump oil level by viewing the sight glass on the side of the pump. When properly filled, the oil will be at the half way point marked by the two triangles. Your pressure washer pump is shipped with oil. Add oil only if oil level is lower than the half way point on the sight glass. **Do not overfill.** Use 30 weight **non-detergent** oil if necessary.

▲ CAUTION: Do Not use engine oil that has been shipped with your unit in your pump. Engine oil is detergent and your pump uses a non-detergent oil. Detergent oil can cause damage to your pump.

Engine Oil

Your unit has been shipped **without** oil in the engine. A bottle of SAE 30 weight oil is included in the carton. Remove oil plug located on the side of engine. Using a funnel, fill engine crankcase up to the last thread in the oil port. Pour slowly. Oil reading will be inaccurate on unlevel ground.

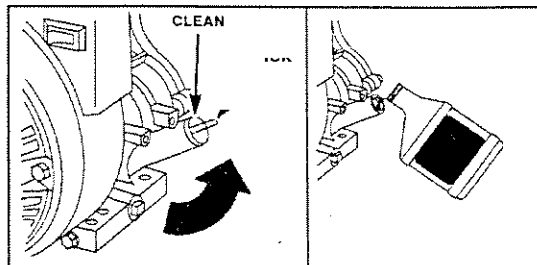

NOTE: When adding oil to the engine crankcase, use a high quality detergent oil classified "For Service SF, SG, SH rated SAE 30 weight". Use no special additives. Select the oil's viscosity grade according to your expected operating temperatures.

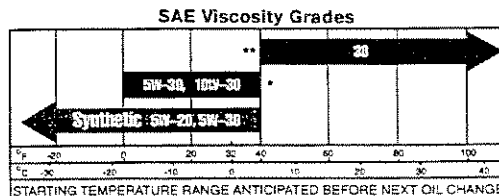

Air cooled engines run hotter than automotive engines. The use of multi-viscosity oil such as (10W-30, etc.) in ambient temperatures above 40°F (4°C) will result in higher than normal oil consumption. If multi-viscosity oil is used, check the oil level more frequently to prevent any possible engine damage due to lack or lubrication. Use of SAE30 oil below 40°F (4°C) will result in hard starting and possible engine damage due to inadequate lubrication.

Gasoline

Your pressure washer engine is 4 cycle. Use unleaded fuel only.

▲ CAUTION: Do not overfill the fuel tank. Always allow room for fuel expansion.

▲ WARNING: Never fill fuel tank indoors. Never fill fuel tank when engine is running or hot. Do not smoke or have open flame when filling fuel tank.

Use clean, fresh, regular unleaded gasoline with a minimum of 85 octane. Do not mix oil with gasoline. If unleaded fuel is not available, leaded fuel may be used.

IMPORTANT: It is important to prevent gum deposits from forming in essential fuel system parts such as the carburetor, fuel filter hose or tank during storage. Also, experience indicates that alcohol-blended fuels (called gasohol or using ethanol or methanol) can attract moisture which leads to separation and formation of acids during storage. Acidic gas can damage the fuel system of an engine while in storage. To avoid engine problems, the fuel system should be emptied before storage of 30 days or longer. Never use engine or carburetor cleaner products in the fuel tank or permanent damage may occur.

▲ CAUTION: Never start pressure washer with out water source turned on and connected to pressure washer.

To Start Your Pressure Washer

Make sure fuel shutoff valve is turned to the open position.

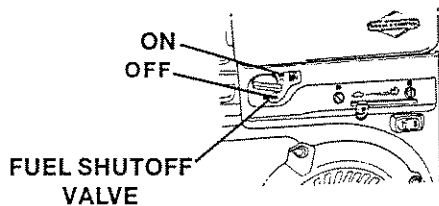

- Remove gas cap
- Add unleaded gasoline, slowly, to fuel tank.
- Do not overfill.

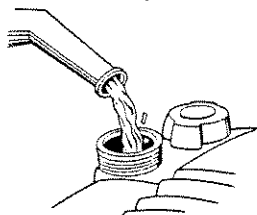

- Connect garden hose to the water inlet on the pressure washer. Tighten by turning water inlet counterclockwise.

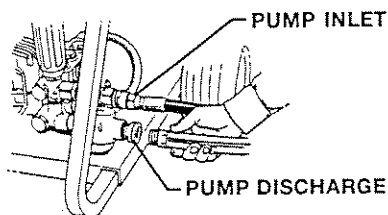

- Connect high pressure hose to discharge on pump.
- Connect the garden hose to the water spout and turn water supply on.

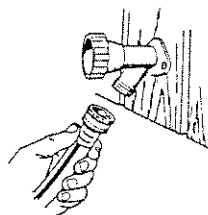

- Squeeze trigger on pressure washer wand to relieve air pressure caused by turning on the water. Water will spew out of the gun in a thin stream. This will make it easier to start the engine.
- Engage the safety latch on the spray gun. This locks the trigger in place and keeps you from accidentally spraying a high pressure stream.

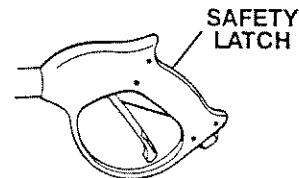

- On the engine there is a choke/run lever. Place lever to the choke position.

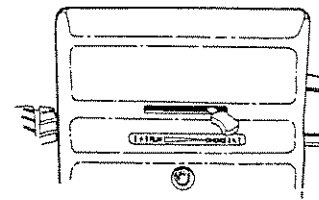

- On the engine there is a throttle control lever. Place throttle to the rabbit position. Always start engine with throttle in the rabbit position. Place on/stop switch to the "on" position.

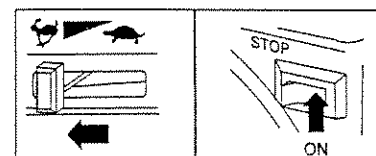

- Make sure fuel shut off valve is to the on position.
- Grasp the starter grip and pull slowly until resistance is felt, then pull firmly to start engine.
- When engine starts, gradually move choke lever to RUN position.
- If engine does not start after 5 pulls, place choke back to run position.
- For hot engine starts make sure choke/run lever is in the run position. Make sure fuel shut off valve is open and throttle is in the Rabbit position.

NOTE: If any leaks are present shut unit down and tighten fittings.

How To Use Your Pressure Washer

On the end of your spray gun wand is a quick connect body. Mounted to your pressure washer handle are five quick connect nozzles.

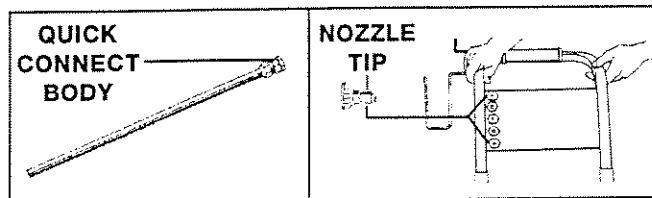

To achieve desired spray pattern, insert one of the five quick connect nozzles. Start by pulling the quick connect sleeve back and then insert the desired nozzle tip. Then press down on the nozzle tip to insure that it is in the locked position and ready to use.

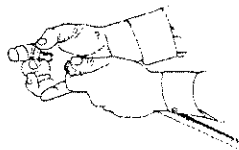

IMPORTANT: When switching out tips, be sure the gun trigger is in the locked position and engine is turned off.

Each nozzle tip will give you a varying degree of spray patterns.

- **Black** - Soap nozzle; used when wanting to draw chemical
- **White** - 40° spray pattern
- **Green** - 25° spray pattern
- **Yellow** - 15° spray pattern
- **Red** - 0° spray pattern

IMPORTANT: If you get spray nozzle too close, especially on high pressure, you may damage the cleaning surface.

- The pressure control knob is located on the pump. You can increase the pressure by turning the knob clockwise or decrease the pressure by turning the knob counterclockwise.

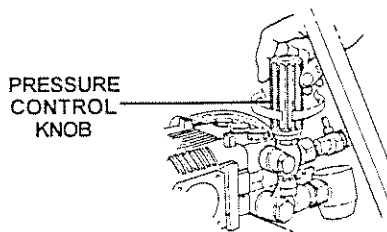

NOTE: The unit is set at its maximum pressure at the factory. Do not attempt to adjust the pressure higher than this factory setting.

Using Soaps/Chemicals

IMPORTANT: Use soaps and chemicals that are designed specifically for use with pressure washers. To apply soap/chemicals follow these steps:

- Prepare the soap/chemical as required by your job.
- Insert soap/chemical line into your container (soap/chemicals not included).



NOTE: The first step involves applying an appropriate soap/chemical solution to penetrate and loosen grime. The soap/chemical is applied at low pressure to avoid splashing, over spray and waste. Leave the solution on surface for 3 to 5 minutes to allow solution to work.

NOTE: The second step involves cleaning the surface you have prepared with the pressure washer and then rinsing it clean.

- Turn the adjustable nozzle counter clockwise to low pressure mode. Soap/chemicals cannot be applied with nozzle in high pressure position.
- Review the use of the adjustable nozzle.
- Connect garden hose to water inlet (see "To Start Your Pressure Washer"), check that high pressure hose is connected to spray gun and pump (see *Assembly*), and start engine.
- Apply soap/chemicals to dry surface, starting from the bottom and working up.
- Allow the soap/chemicals to soak in between 3-5 minutes before washing and rinsing.
- For cleaning, start at lower portion of area to be washed and work upward, using long, even overlapping strokes.

Your pressure washer is equipped with a chemical injector adjustment knob. With the knob fully opened you will get maximum chemical draw. With knob fully closed you will get **no** chemical draw. Turn knob in counter clockwise direction to achieve more chemical draw and clockwise for less chemical draw.

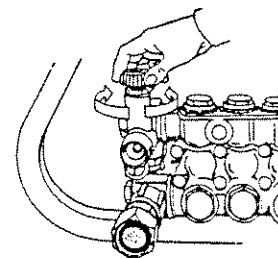

- After using the pressure washer, it is recommended the pump, chemical injector and chemical line be flushed with clear water. To do so, simply place chemical injector hose in water and siphon for 1 to 2 minutes.

MAINTENANCE

CUSTOMER RESPONSIBILITIES TABLE

MAINTENANCE TASK	Before each use	Every 25 hours or yearly	Every 50 hours or yearly	Every 100 hours or yearly
PRESSURE WASHER				
Check/clean inlet screen.	x			
Check high pressure hose.	x			
Check soap and chemical hose and filter	x			
Check gun and wand for leaks.	x			
Purge pump of air and contaminants	x			
Change pump oil	x		x	
ENGINE				
Check oil level	x			
Change engine oil			x	
Clean air cleaner and precleaner		x		
Clean engine muffler & finger guard				x
Clean/replace spark plug				x

Product Specifications

Pressure Washer Specifications

Pressure	2600
Flow Rate	2.7 GPM
Cleaning Units (psi x GPM)	7020

Engine Specifications

RPM	3600
Rated Horsepower	6.5
Spark Plug Gap	0.030" (0.76mm)
Gasoline Capacity	3 Quarts
Oil	SAE 30 weight

General Recommendations

The warranty of the high pressure washer does not cover items that have been subjected to operator abuse or negligence. To receive full value from the warranty, operator must maintain high pressure washer as instructed in this manual.

Some adjustments will need to be made periodically to maintain your high pressure washer.

Once a year you should clean or replace the spark plug and clean or replace the air filter and check the gun and wand assembly for wear. A clean spark plug and clean air filter assure proper fuel-air mixture and help your engine run better and last longer.

NOTE: Over time the o-rings in the gun assembly become worn. Attached to your owners manual is a replacement o-ring and split backup ring.

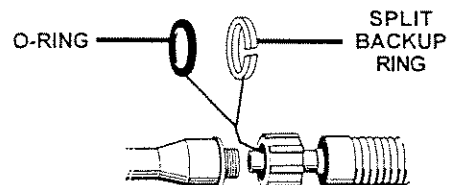

Pressure Washer Maintenance

Check and Clean Inlet Screen: Examine inlet screen on pump inlet fitting. Clean if clogged replace if torn.

Check High Pressure Hose: High pressure hose can develop leaks from wear, kinking, abuse. Inspect hose each time before use. Check for cuts, leaks, abrasions or bulging of cover, damage or movement of couplings. If any of these conditions exist, replace hose immediately.

Check Chemical/Soap Hose: Examine the chemical/soap hose and clean if clogged. Hose should fit tightly on pump fitting. Check for leaks and tears. Replace filter or hose if either is damaged.

Check Gun and Wand: Examine hose connection to gun making sure it is secure. Test trigger by pressing it and making sure it springs back into place when you release it.

Pump Oil

Pump oil level should be checked before each use.

Changing Pump Oil

Oil should be changed after the first 10 hours of operation. Subsequent changes after each 50 hours of operation. To drain oil, simply remove oil plug with an adjustable wrench. The oil plug is located at the bottom of the pump. Dispose of used oil. Properly remove pump oil fill plug. Add 30 weight non-detergent oil. Fill until oil level is at the mid point on the sight glass.

Purge Pump of Air and Contaminants

To remove the air from the pump, follow these steps:

- Set up the pressure washer as described in *Assembly* section and connect the water supply.
- Remove the wand extension from the spray gun.
- Pull the trigger on the gun and hold.

To remove the contaminants from the pump, follow these steps:

- Set up the pressure washer as described in *ASSEMBLY* section, connect the water supply.
- Remove the wand extension from the spray gun.
- Start the engine according to instructions in the *OPERATION* section.

- Pull the trigger on the gun and hold.
- When the water supply is steady and constant, disengage trigger and refasten the wand extension.

Engine Maintenance

Oil

- Oil level should be checked prior to each use or at least every 5 hours of operation. To check oil see *Adding Engine Oil* on page 9.

Changing Engine Oil

For a new engine, change oil after the first 5 hours of operation. Thereafter, change oil after every 50 hours of operation.

Change the oil while the engine is still warm. The oil will flow freely and carry away more impurities. Make sure the engine is level when filling, checking, or changing oil.

Change the oil as follows:

- To keep dirt, grass, etc., out of the engine, clean the area around the drain plug and oil plug before removing it.
- Remove the oil drain plug and oil plug. Tilt the engine slightly towards the oil drain to obtain better drainage. Be sure to allow ample time for complete drainage.

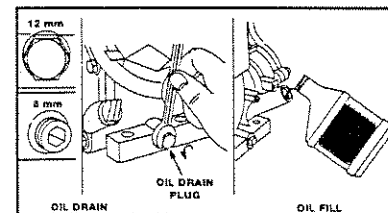

- Reinstall the drain plug. Make sure it is tightened securely.
- Fill the crankcase with new oil of the proper type, to up to the thread in the oil port. Pour slowly.
- Reinstall the oil fill cap or plug and tighten securely.

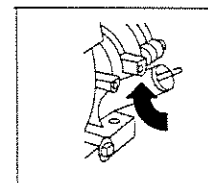

Cleaning Pre-Clean and Air Cleaner Cartridge

To clean pre-cleaner and air cleaner cartridge wash in liquid detergent and water. Allow to dry thoroughly before using. Do not oil pre-cleaner. Replace if very dirty or damaged.

To service air cleaner follow these steps:

1. Unscrew cover screws. Remove cover, foam pre-cleaner, and air cleaner cartridge assembly.
2. Remove cartridge from cover, then retainer (if equipped) and pre-cleaner.
3. To clean pre-cleaner and air cleaner cartridge, wash in liquid detergent and water. Allow to dry thoroughly before using. Do not oil the pre-cleaner or cartridge. Replace if very dirty or damaged.

NOTE: Do not use petroleum solvents, e.g., kerosene, which will cause the cartridge to deteriorate. Do not use **pressurized air** to clean cartridge. Pressurized air can damage the cartridge.

4. Reassemble pre-cleaner or retainer (if equipped.) Place in cover with pre-cleaner mesh side toward cartridge. Place cartridge in retainer in cover.
5. Push cover and air cleaner assembly squarely onto base (tabs must be in slots, if equipped) and hold firmly. Tighten cover screws securely.

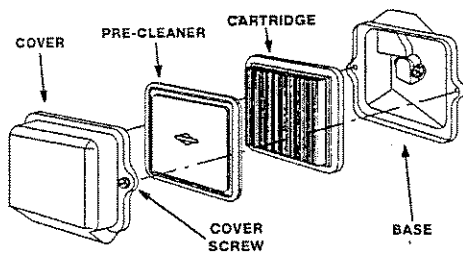

Check Engine— Guard/Muffler

Do not clean engine with a forceful spray of water because water could contaminate fuel system. With a brush or cloth clean finger guard after every use to prevent engine damage caused by overheating.

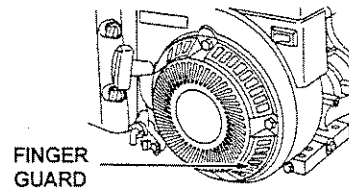

Before running engine, clean muffler area to remove all combustible debris.

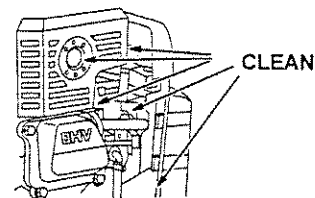

Clean and Replace Spark Plug

Change the spark plug every 100 hours of operation or once each year, whichever comes first. This will help your engine to start easier and run better.

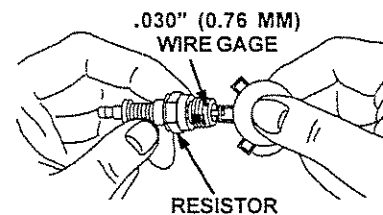

SERVICE AND ADJUSTMENTS

Carburetor

The carburetor of your high pressure washer is pre-set at the factory. The carburetor should not be tampered with. If your pressure washer is used at an altitude in excess of 5000 feet consult with your nearest Sears Service Center regarding high altitude set changes.

▲ CAUTION: Engine speed was properly adjusted at the factory and should require no additional adjustment. Do not attempt to change engine speed. If you believe the engine is running too fast or too slow, take your pressure washer to a Sears Authorized Service Center for repair and adjustment.

▲ WARNING: High engine speeds are dangerous and increase the risk of personal injury or damage to equipment.

▲ WARNING: Low engine speeds impose a heavy load on the engine and when sufficient engine power is not available could shorten engine life.

Nozzle Maintenance

1. Shut off the pressure washer and turn off the water supply.
2. Disconnect spark plug wire.
3. Pull trigger on gun handle to relieve any water pressure.
4. Disconnect the wand/lance from the gun.
5. Remove the nozzle from the wand. Remove any obstructions with the nozzle cleaning tool provided and backflush with clean water.
6. Direct water supply into nozzle end to backflush loosened particles for 30 seconds.
7. Reassemble the nozzle to the lance using teflon tape to prevent leaks. Tighten securely.
8. Reconnect wand to gun and turn on water supply.
9. Start pressure washer and place wand into high pressure setting to test.

STORAGE

Preparing Pressure Washer for Storage

NOTE: If you do not plan to use your unit for 30 days or more, unit should be prepared for storage.

IMPORTANT: It is important to prevent gum deposits from forming in essential fuel system parts such as the carburetor, fuel filter hose or tank during storage. Also, experience indicates that alcohol-blended fuels (called gasohol or using ethanol or methanol) can attract moisture which leads to separation and formation of acids during storage. Acidic gas can damage the fuel system of an engine while in storage. To avoid engine problems, the fuel system should be emptied before storage of 30 days or longer. Never use engine or carburetor cleaner products in the fuel tank or permanent damage may occur.

Engine Preparation

- First add a fuel stabilizer to the fuel tank.
 - Run pressure washer for full 5 minutes to allow fuel stabilizer to enter the fuel system.
- NOTE:** While doing this procedure make sure water supply is turned on and flowing to the unit. **NEVER** run unit without water supply running through pump.
- Next shut off engine and disconnect the water supply.
 - Disconnect the spark plug wire and remove the spark plug.
 - Add one teaspoon of oil through the spark plug hole.

- Place rag over spark plug hole and pull the recoil a few times to lubricate the combustion chamber.
- Replace the spark plug, but do not connect the spark plug wire.

Pump Preparation

This pressure washer should be stored in such a way to protect it from freezing. Do not store this unit outdoors or in an area where temperatures will fall below 32° F. This can cause extensive damage to this unit.

If unit has to be stored under freezing conditions a non-toxic R.V. anti-freeze can be used to protect from freezing.

- Be sure engine switch is in "OFF" position and spark plug wire has been removed from spark plug.
- Pull the trigger on the spray gun to release the pressure in the high pressure hose. Detach high pressure hose and garden hose from the unit.
- Pull the recoil on the engine 4 to 6 times to discharge remaining water in pump.
- Tip the unit on the end with the water inlet fitting pointing upward.
- Pour approximately 1/4 cup of non-toxic R.V. anti-freeze down the fitting where the water hose attaches to the pump.
- Set unit upright and pull starter handle on engine 4 to 6 times to circulate anti-freeze in pump until anti-freeze is discharged from the pump.

TROUBLESHOOTING

SYMPTOM	CAUSE	SOLUTION
Engine won't start	<ol style="list-style-type: none"> 1. Engine throttle is in "OFF" Position. 2. Choke lever has not been placed to choke. 3. Pressure buildup after initial use. 	<ol style="list-style-type: none"> 1. Slide throttle to "Rabbit" position. 2. Slide choke lever to choke position. 3. Depress trigger gun.
Won't Draw Chemical	<ol style="list-style-type: none"> 1. Nozzle not in chemical draw position. 2. Chemical screen is obstructed. 3. Chemical screen not working. 4. Chemical injector orifice obstructed or stuck. 5. Chemical injector closed. 	<ol style="list-style-type: none"> 1. Place nozzle to low pressure. 2. Check chemical screen; clean if obstructed. 3. Make sure chemical screen is submerged in chemical/water. 4. Check and clean. 5. Open chemical injector by turning adjustment knob.
Pump running normally but pressure does not achieve rated values	<ol style="list-style-type: none"> 1. Water supply restricted. 2. Nozzle is in low PSI position. 3. Nozzle incorrect or worn. 4. Pump sucking air. 5. Nozzle blocked. 	<ol style="list-style-type: none"> 1. Check water supply and filter screen for blockage. Check hoses for blockage, kinks, leaks, etc. 2. Twist nozzle at end of wand clockwise the high pressure position. 3. Check and replace. 4. Check that hoses and fittings are airtight. 5. Clean nozzle.
Fluctuating Pressure	<ol style="list-style-type: none"> 1. Pump sucking air. 2. Garden hose inlet strainer clogged. 3. Worn Seals or Packing. 4. Inadequate water supply. 5. Fouled or dirty inlet or discharge valves. 6. Leaky discharge hose. 	<ol style="list-style-type: none"> 1. Check that hoses and fittings are air tight. Purge air from garden hose. 2. Clean. Check filter frequently. 3. Check and replace. 4. Check hose for kinks. 5. Check flow available to pump. Check for excessive heat, 145° F or above. 6. Clean inlet and discharge valve assemblies. Replace if damaged.
Pressure drops after period of normal use	<ol style="list-style-type: none"> 1. Nozzle clogged, partially obstructed. 2. Nozzle worn. 3. Pump Valves worn, dirty or stuck. 4. Worn pump piston packing. 	<ol style="list-style-type: none"> 1. Use nozzle cleaning kit to clear obstruction. (See Nozzle Maintenance under Service Adjustment.) 2. Clean or replace. 3. Check and replace. 4. Check and replace.
Pump noisy	<ol style="list-style-type: none"> 1. Water too hot. 2. Pump sucking air. 3. Valves dirty or worn. 4. Worn bearings. 	<ol style="list-style-type: none"> 1. Reduce temperature below 63° C or 145° F. 2. Check that hoses and fittings are airtight. 3. Check, clean or replace. 4. Check and replace if necessary.
Presence of water in oil (oil milky).	<ol style="list-style-type: none"> 1. High humidity. 2. Piston packing and oil seal worn. 	<ol style="list-style-type: none"> 1. Change Oil. 2. Check and replace oil seals.
Water dripping from pump	<ol style="list-style-type: none"> 1. Thermal relief functioning normal. 2. Fittings Loose. 3. O-rings of piston guide or retainer worn. 4. Piston packing worn. 	<ol style="list-style-type: none"> 1. Protecting pump, if not using pressure washer for a long period of time, shutoff engine. 2. Tighten. 3. Check and replace. 4. Check and replace.
Oil Dripping	<ol style="list-style-type: none"> 1. Oil seal worn 2. Loose drain plug or worn drain plug o-ring. 	<ol style="list-style-type: none"> 1. Check and replace 2. Tighten drain plug or replace o-ring. Do not over torque.

PARTS

CRAFTSMAN 2600 PSI HIGH PRESSURE WASHER 919.769020

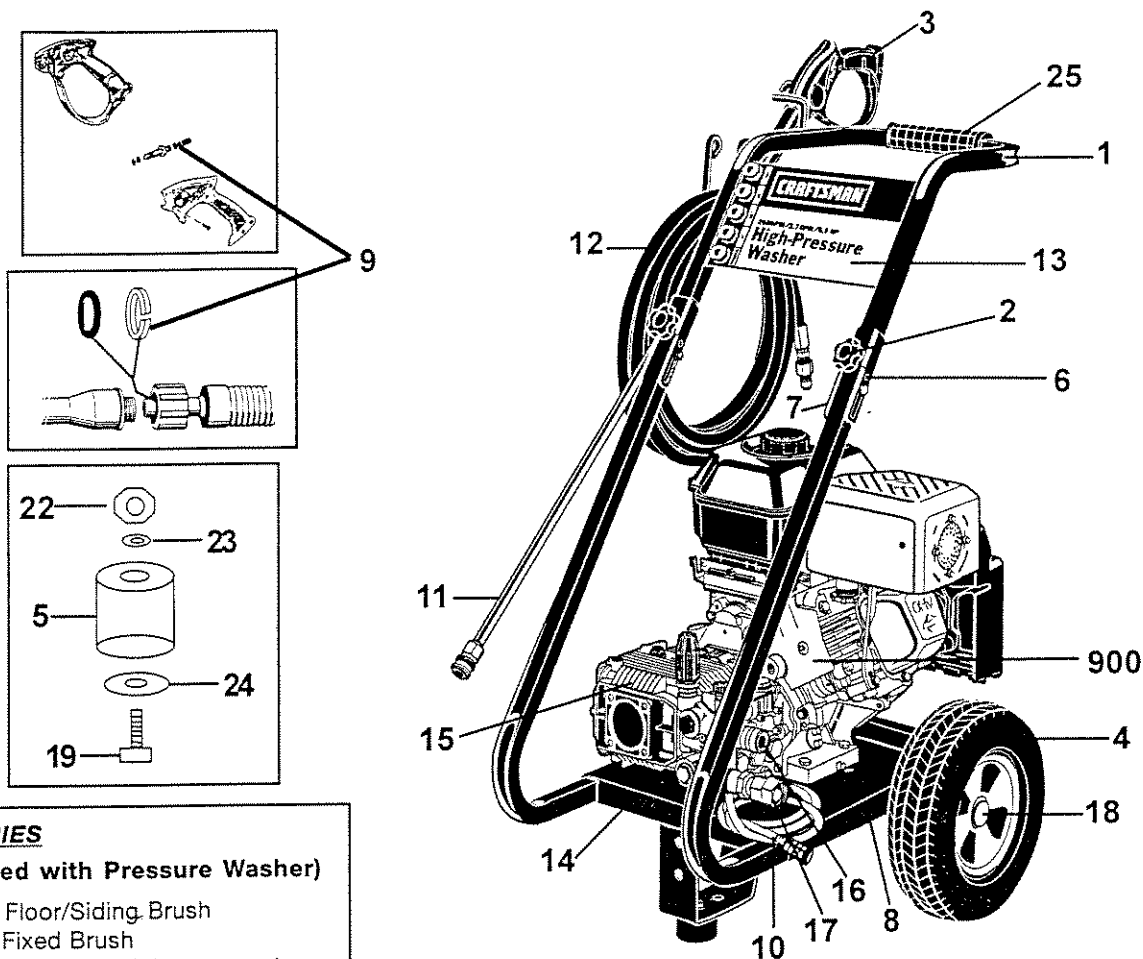

ACCESSORIES

(Not Included with Pressure Washer)

- 919.76430 Floor/Siding Brush
- 919.76431 Fixed Brush
- 919.76450 25Ft. 3/8" high pressure hose
- 919.76451 50Ft. 3/8" high pressure hose

KEY#	PART NUMBER	DESCRIPTION	KEY#	PART NUMBER	DESCRIPTION
1	17597	Handle	22	F119	Hex Nut
2	C042	Knob	23	F078	Lock Washer
3	16496	Gun	24	F112	Flat Washer
4	17624	Tire Semi-Pneumatic	25	17367	Handle Grip
5	16371	Foot Rubber			
6	17712	Screw HAC 5/16"			
7	F469	Lock Nut 5/16"			
8	17720	Frame			
9	AL-650015	O-ring Kit			
10	H100	Chemical Hose			
11	17648	QC Lance			
12	15111	High Pressure Hose			
13	17600	Decal Front Craftsman			
900	-----	Engine (Refer to Engine Breakdown Briggs #121432-0112-E1)			
14	16727	Decal Operation			
15	PK16642	Pump			
16	F035	High Pressure QC			
17	16829	Adapter- Garden Hose			
18	F464	Nut Pal 1/2"			
19	F064	Screw Hex HDC			

PARTS NOT ILLUSTRATED

- MGP-769020 Owners Manual
- F078 Lockwasher, Engine to Frame
- F119 Nut Hex 5/16 Engine to Frame
- F066 Screw 5/16 Engine to Frame
- F107 Lockwasher-Pump to Engine
- 15167 Srew, Hex- Pump to Engine
- F078 Lockwasher- Pump to Engine
- NCT001 Nozzle Cleaning Kit
- F039 QC Socket for HP Hose
- 17732 Nozzle Kit 0, 25, 40 Soap
- 16927 Nozzle 0°
- 16928 Nozzle 15°
- 16929 Nozzle 25°
- 16930 Nozzle 40°
- 16931 Nozzle Soap

PUMP PARTS

CRAFTSMAN 2600 PSI HIGH PRESSURE WASHER 919.769020

PUMP BREAKDOWN MODEL PK16642

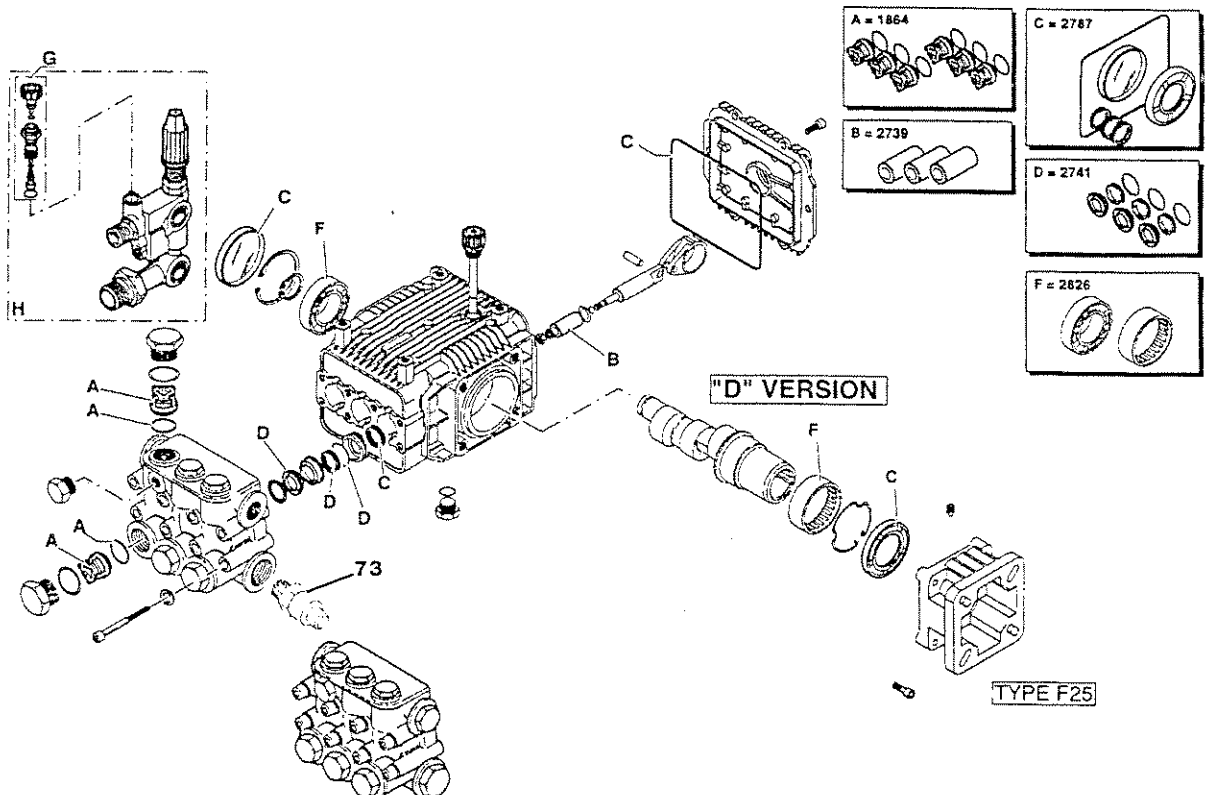
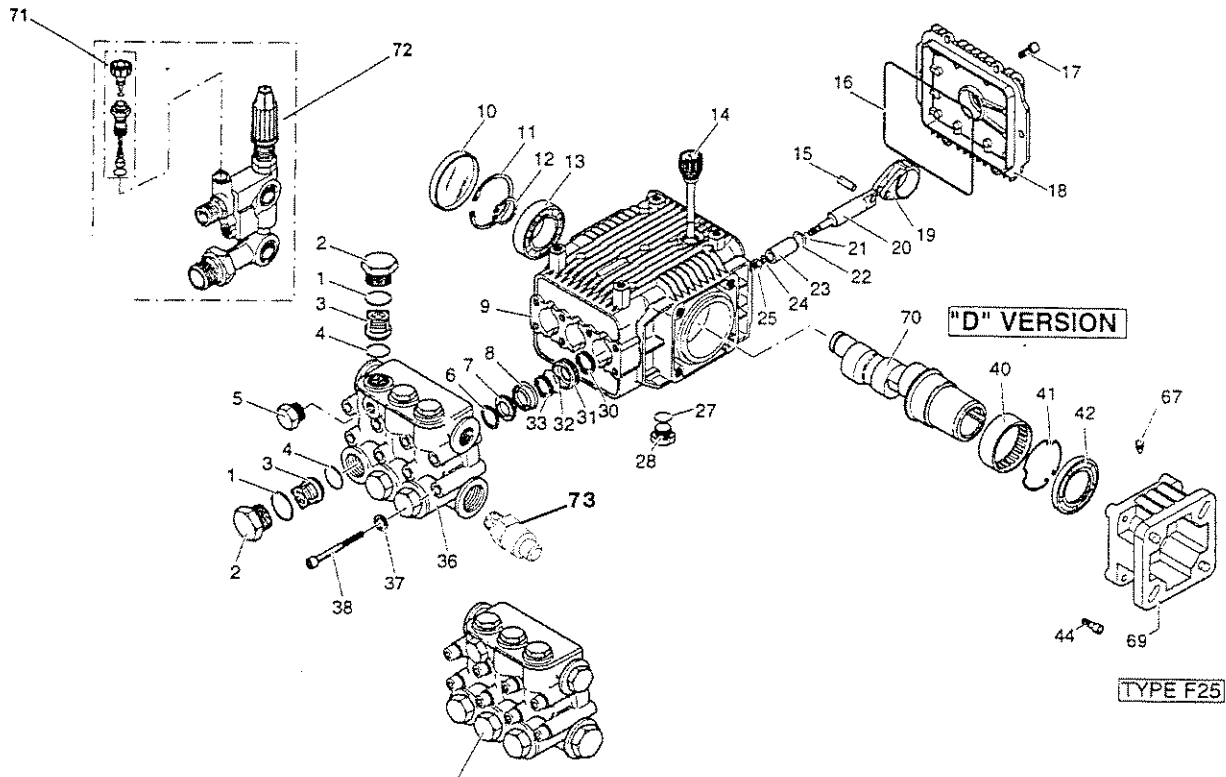

PUMP PARTS

CRAFTSMAN 2600 PSI HIGH PRESSURE WASHER 919.769020

PUMP BREAKDOWN PK16642

REF. NO.	PART NO.	DESCRIPTION	QTY.	REF. NO.	PART NO.	DESCRIPTION	QTY.
1	AR-960160	O-Ring	6	23	AR-1780070	Piston	3
2	AR-1260162	Plug	6	24	AR-1260100	Piston washer	3
3	AR-1269050	Complete valve	6	25	AR-1260110	Nut	3
4	AR-880830	O-Ring	6	27	AR-740290	O-Ring	2
5	AR-620301	Plug	1				
6	AR-1780130	Support ring	3	28	AR-880530	Plug	2
7	AR-1260130	Gasket	3	30	AR-1260460	Seal	3
8	AR-1780090	Piston guide	3	31	AR-1780100	Rear Piston guide	3
9	AR-1780010	Pump body	1	32	AR-770260	O-Ring	3
10	AR-1266740	Cap	1	33	AR-1260440	Gasket	3
11	AR-1260790	Circlip	1	36	AR-1780380	Head	1
12	AR-1780550	Snap ring	1	37	AR-1381550	Washer	8
13	AR-1780490	Bearing	1	38	AR-680570	Screw	8
14	AR-880130	Oil cap	1	40	AR-1321190	Bearing	1
15	AR-1780050	Piston pin	3	41	AR-1321080	Snap ring	1
16	AR-1780510	O-Ring	1	42	AR-480671	Seal	1
17	AR-1200430	Screw	6	44	AR-180030	Screw	4
18	AR-1789010	Complete cover	1	67	AR-820440	Grub screw	1
19	AR-1780040	Con rod	3	68	AR-1789200	Pump head pre-ass.	1
20	AR-1780060	Guiding piston	3	69	AR-1380580	Gas engine flange	1
21	AR-480480	O-Ring	3	70	AR-1780590	Hollow shaft 3/4"	1
22	AR-1260091	Spacer disc	3	71	16747	Chemical Injector	1
				72	AR-2973	Unloader	1
				73	16506	Thermal Relief Valve	1

AR-1780580

PARTS KITS							
A=KIT 16739 Valves		B=KIT 16746 Pistons		C=KIT 16748 Oil Seals for D Version			
Pos.	Qty.	Pos.	Qty.	Pos.	Qty.		
3	6	23	3	10	1		
4	6			16	1		
				30	3		
				42	1		
D=KIT 16745 Water Seals		F=KIT 16749 Bearings		G=KIT 16747 Injector Kit		H=KIT 16744 Unloader O-Ring Kit	
Pos.	Qty.	Pos.	Qty.	Pos.	Qty.	Pos.	Qty.
7	3	13	1	71	1		
32	3	40	1				
33	3						

ENGINE PARTS

CRAFTSMAN 2600 PSI HIGH PRESSURE WASHER 919.769020

BRIGGS ENGINE MODEL #121432-0112-E1

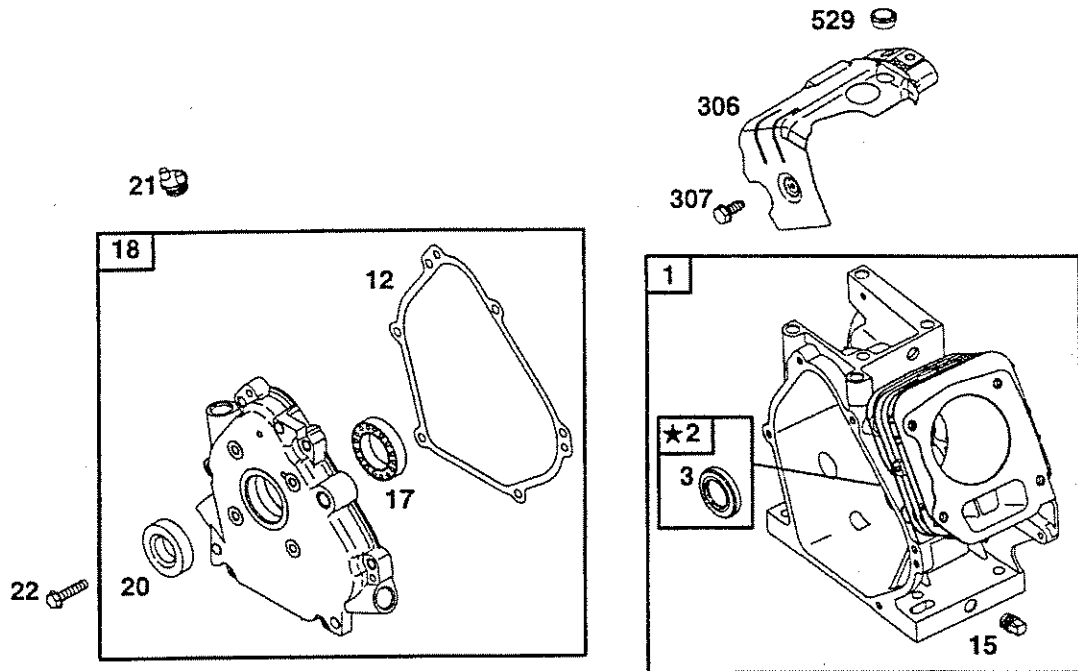

REF. NO.	PART NO.	DESCRIPTION	REF. NO.	PART NO.	DESCRIPTION	REF. NO.	PART NO.	DESCRIPTION
1	690045(P)	Cylinder Assembly	17	692510	Bearing-Ball	306	692552	Shield-Cylinder
2	399269	Bushing	18	690047	Cover-Crankcase	307	690345	Screw-Hex.
3	692266	Seal-Oil	20	692550	Seal-Oil	529	692553	Grommet
12	692549	Gasket-Crankcase	21	692261	Cap-Oil Fill	1019	690035	Label Kit
15	691696	Plug-Oil	22	692551	Screw-Hex.	1058	273700	Owner's Manual

ENGINE PARTS

CRAFTSMAN 2600 PSI HIGH PRESSURE WASHER 919.769020

BRIGGS ENGINE MODEL #121432-0112-E1

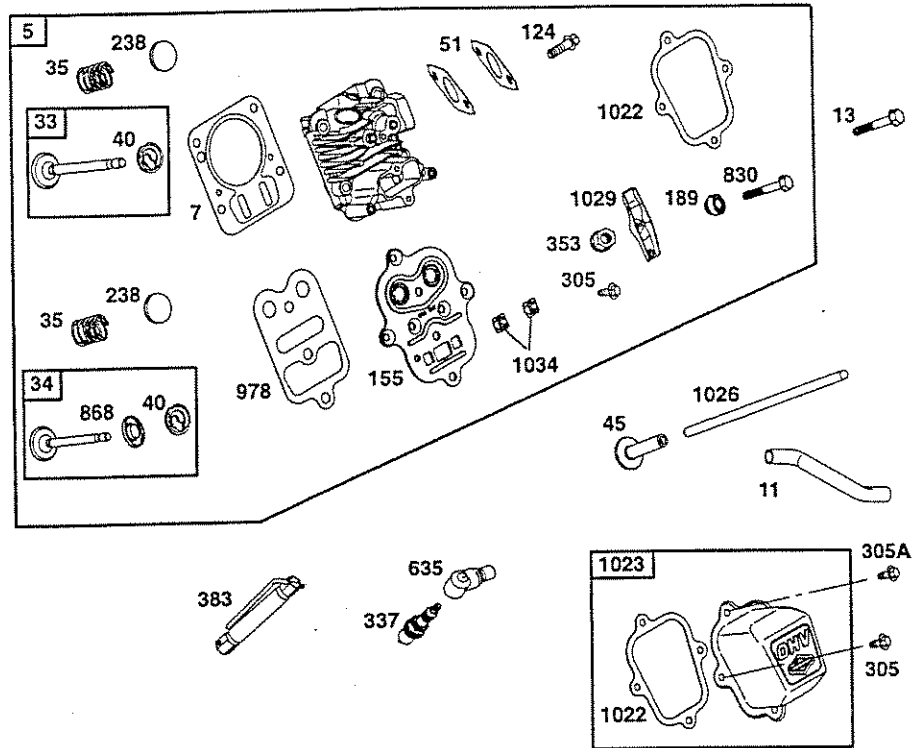

REF. NO.	PART NO.	DESCRIPTION	REF. NO.	PART NO.	DESCRIPTION	REF. NO.	PART NO.	DESCRIPTION
5	499922	Head-Cylinder	155	692556	Plate-Cylinder Head	868	692044	Seal-Valve
7	692554	Gasket-Cylinder Head	189	691295	Ball-Rocker Arm	978	691892	Gasket-Plate
11	692600	Tube-Breather	238	691300	Cap-Valve	1022	691890	Gasket-Rocker Cover
13	691137	Screw-Hex.	305	691108	Screw-Hex.	1023	499924	Cover-Rocker
33	499642	Valve-Exhaust	305A	692557	Screw-Hex.	1026	692560	Rod-Push
34	499641	Valve-Intake	337	690965	Plug-Spark	1029	691230	Arm-Rocker
35	691304	Spring-Valve	353	692558	Nut-Hex.	1034	691343	Guide-Push Rod
40	692194	Retainer-Valve	383	19374	Wrench-Spark Plug			
45	690977	Tappet-Valve	635	692186	Boot-Spark Plug			
51	692555	Gasket-Intake	830	692559	Screw-Hex.			
124	692568	Screw-Hex.						

ENGINE PARTS

CRAFTSMAN 2600 PSI HIGH PRESSURE WASHER 919.769020

BRIGGS ENGINE MODEL #121432-0112-E1

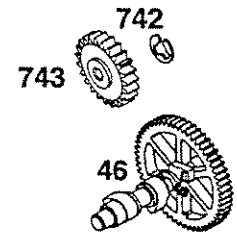
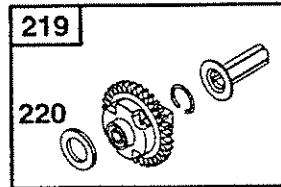
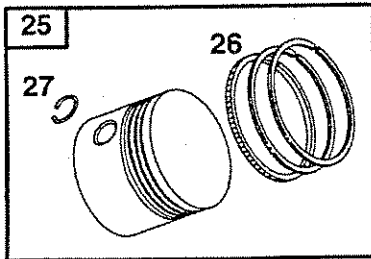
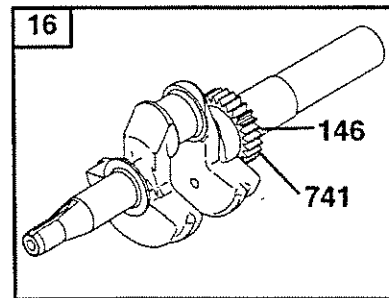
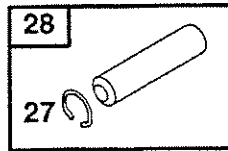
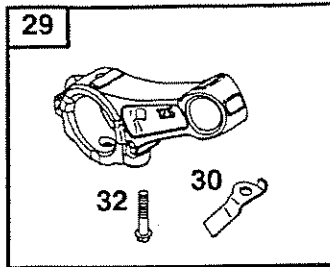

REF. NO.	PART NO.	DESCRIPTION	REF. NO.	PART NO.	DESCRIPTION	REF. NO.	PART NO.	DESCRIPTION
16	692561	Crankshaft	29	690124	Rod-Connecting	146	690979	Key-Timing
17	692510	Bearing-Ball	30	692562	Dipper-Connecting Rod	219	692418	Gear-Governor
24	690974	Key-Flywheel	32	691664	Screw-Connecting Rod	220	691724	Washer-Thrust
25	499627	Piston Assembly	46	692563	Gear-Cam	741	692565	Gear-Timing
26	499631	Ring Set				742	692564	Ring-Retaining
27	691866	Lock-Piston Pin				743	692566	Gear-Idler
28	499423	Pin-Piston						

ENGINE PARTS

CRAFTSMAN 2600 PSI HIGH PRESSURE WASHER 919.769020

BRIGGS ENGINE MODEL #121432-0112-E1

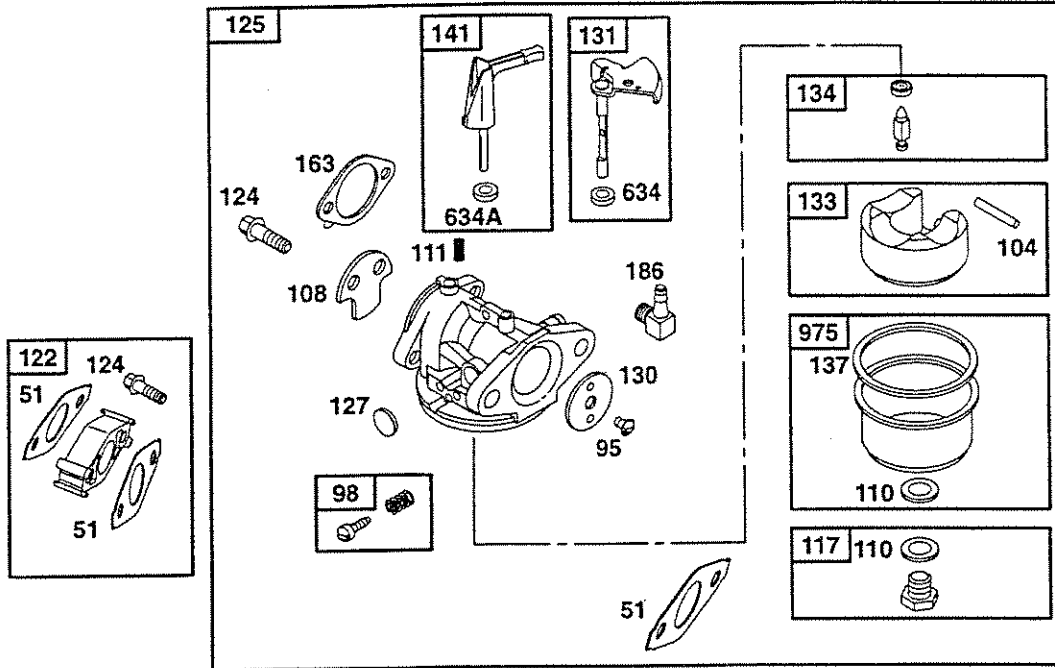

REF. NO.	PART NO.	DESCRIPTION	REF. NO.	PART NO.	DESCRIPTION	REF. NO.	PART NO.	DESCRIPTION
51	692555	Gasket-Intake (2 Required)	117	690048	Jet-Main (Standard)	137		Gasket-Float Bowl (Sold in Kit Only)
95	691636	Screw-Slotted	122	690043	Spacer-Carburetor	141	699023	Shaft-Choke
98	398185	Screw-Idle Speed	127		Plug-Welch (Sold in Kit Only)	163	691887	Gasket-Air Cleaner
104	691242	Pin-Float Hinge	130	691181	Valve-Throttle	186	692317	Connector-Hose
108	692567	Valve-Choke	131	699024	Shaft-Throttle	634		Washer (Sold in Kit Only)
110		Washer-Seal (Sold in Kit Only)	133	398187	Float-Carburetor	634A		Washer (Sold in Kit Only)
111	690572	Spring-Friction (Choke)	134	398188	Valve-Needle	975	493640	Bowl-Float

ENGINE PARTS

CRAFTSMAN 2600 PSI HIGH PRESSURE WASHER 919.769020

BRIGGS ENGINE MODEL #121432-0112-E1

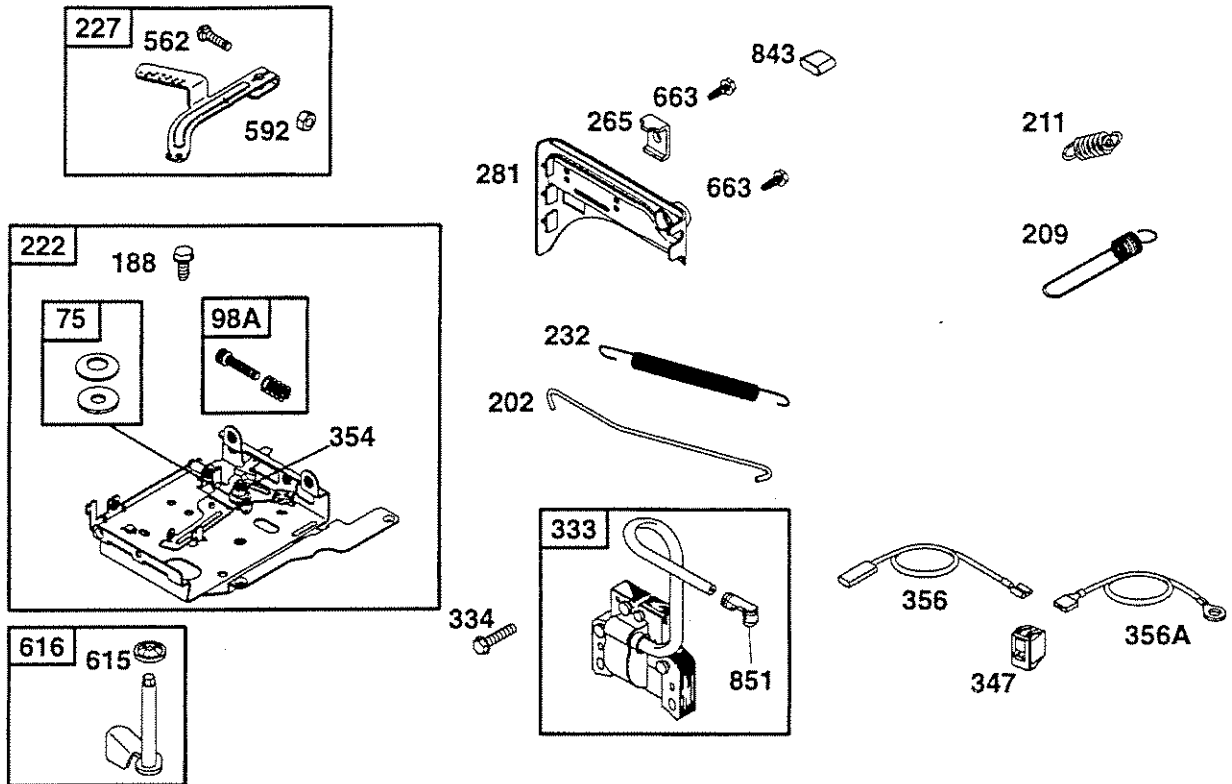

REF. NO.	PART NO.	DESCRIPTION	REF. NO.	PART NO.	DESCRIPTION	REF. NO.	PART NO.	DESCRIPTION
75	495659	Washer Set	232	692570	Spring-Link	356A	692603	Wire-Stop
98A	493280	Screw-Idle Speed	265	691024	Clamp-Casing	562	691112	Bolt-Governor Level
188	690877	Screw-Hex.	267	690804	Screw-Slotted Hex.	592	691251	Nut-Hex.
202	692569	Link-Mechanical Governor	281	692574	Panel-Control	615	692576	Retainer-Governor
209	692569	Spring-Governor	333	692605	Armature-Magneto	616	692547	Crank-Governor
211	691798	Spring-Governor	334	691061	Screw-Hex.	663	692577	Screw-Slotted Hex.
222	692572	Bracket-Control	347	692599	Switch-Rocker	843	692578	Sleeve-Lever
227	692573	Lever-Governor	354	692575	Nut-Lock	851	493880	Terminal-Cable

ENGINE PARTS

CRAFTSMAN 2600 PSI HIGH PRESSURE WASHER 919.769020

BRIGGS ENGINE MODEL #121432-0112-E1

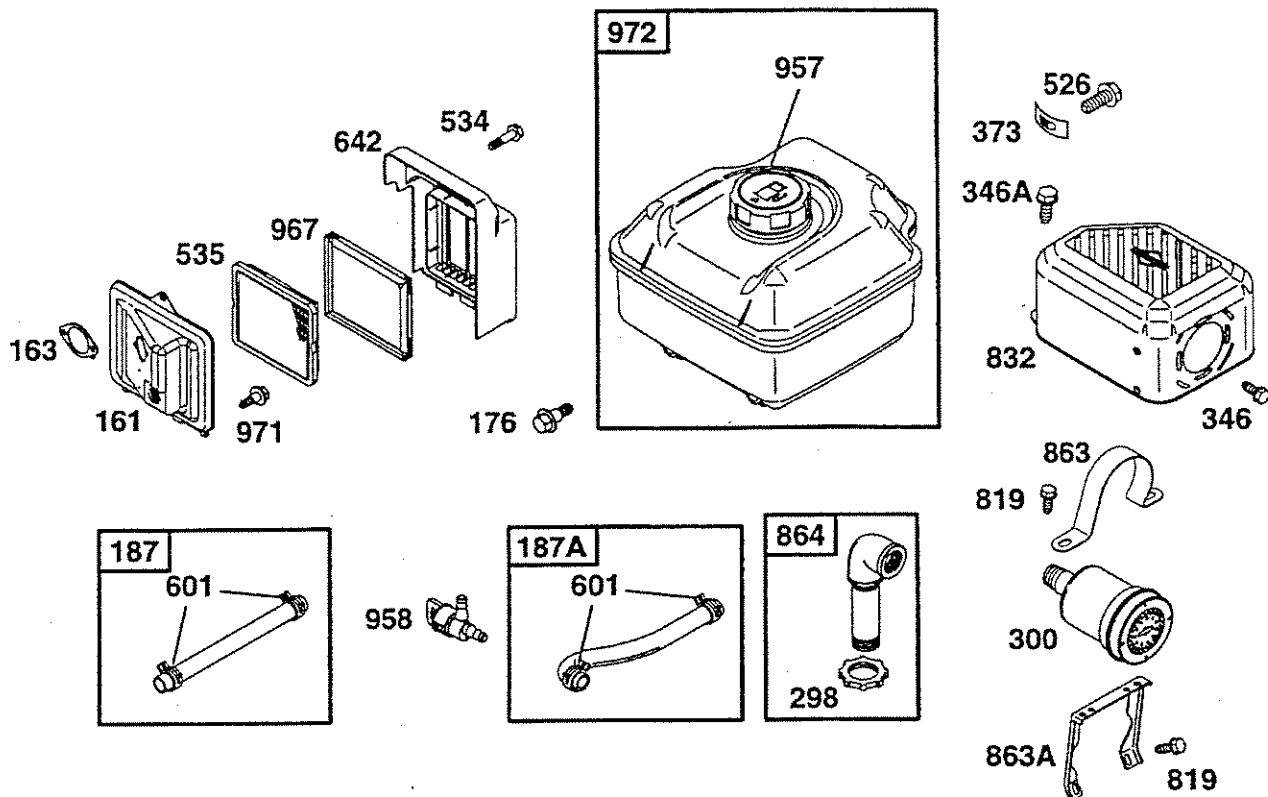

REF. NO.	PART NO.	DESCRIPTION	REF. NO.	PART NO.	DESCRIPTION	REF. NO.	PART NO.	DESCRIPTION
161	692579	Base-Air Cleaner	346	690661	Screw-Hex.	863	692595	Bracket-Muffler
163	691887	Gasket-Air Cleaner	346A	692581	Screw-Hex.	863A	692596	Bracket-Muffler
176	692127	Screw-Shoulder	373	692582	Nut-Tinnerman	864	692548	Adapter-Muffler
187	298049	Line-Fuel (Cut to Required Length)	526	691127	Screw-Hex.	957	691654	Cap-Fuel Tank
187A	692601	Line-Fuel (Molded)	534	692583	Screw-Slotted Hex.	958	692586	Valve-Shutoff
298	690453	Locknut-Muffler	535	691710	Filter-Air	967	691706	Filter-Air (Pre-Filter)
300	692580	Muffler-Exhaust	601	692201	Clamp-Hose	971	691106	Screw-Shoulder
			642	692584	Cover-Air Cleaner	972	692587	Tank-Fuel
			819	692598	Screw-Hex.			
			832	692584	Guard-Muffler			

ENGINE PARTS

CRAFTSMAN 2600 PSI HIGH PRESSURE WASHER 919.769020

BRIGGS ENGINE MODEL #121432-0112-E1

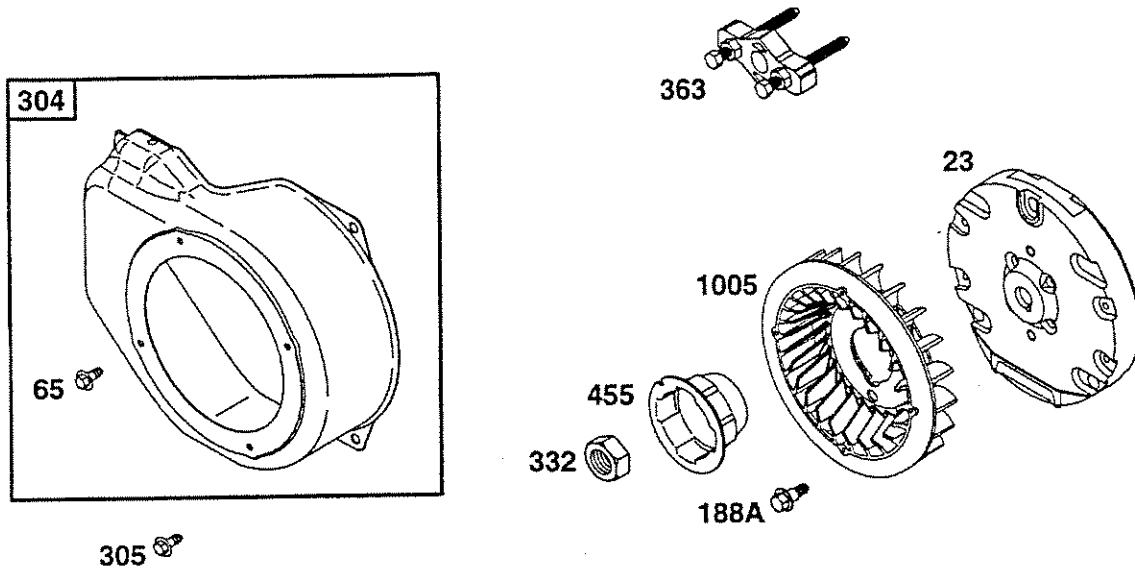

REF. NO.	PART NO.	DESCRIPTION	REF. NO.	PART NO.	DESCRIPTION	REF. NO.	PART NO.	DESCRIPTION
23	692588	Flywheel	304	692589	Housing-Blower	363	19069	Flywheel Puller
65	692608	Screw-Hex.	305	691108	Screw-Hex.	455	692591	Cup-Flywheel
188A	692590	Screw-Shoulder	332	690662	Nut-Flywheel	1005	692592	Fan-Flywheel

ENGINE PARTS

CRAFTSMAN 2600 PSI HIGH PRESSURE WASHER 919.769020

BRIGGS ENGINE MODEL #121432-0112-E1

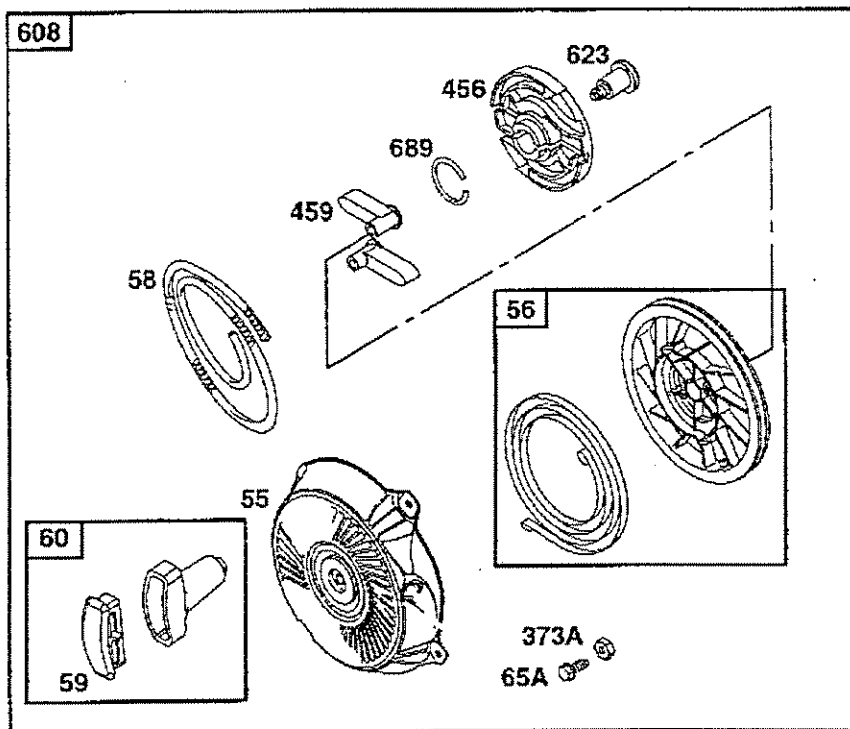

REF. NO.	PART NO.	DESCRIPTION	REF. NO.	PART NO.	DESCRIPTION	REF. NO.	PART NO.	DESCRIPTION
55	691422	Housing-Rewind Starter	60	393152	Grip-Starter Rope	459	692260	Pawl-Ratchet
56	498144	Pulley-Starter	60A	691930	Grip-Starter Rope	608	497830	Starter-Rewind
58	692593	Rope-Starter (Cut To Suit)	65A	690837	Screw-Hex.	623	691696	Screw-Shoulder
59	692594	Insert-Grip	373A	690800	Nut-Hex.	689	691855	Spring-Friction
			456	692299	Retainer-Spring			

ENGINE PARTS

CRAFTSMAN 2600 PSI HIGH PRESSURE WASHER 919.769020

BRIGGS ENGINE MODEL #121432-0112-E1

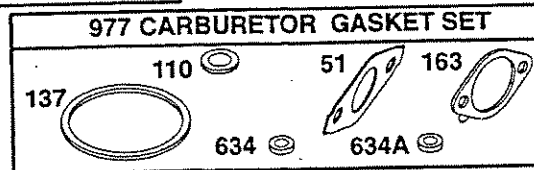
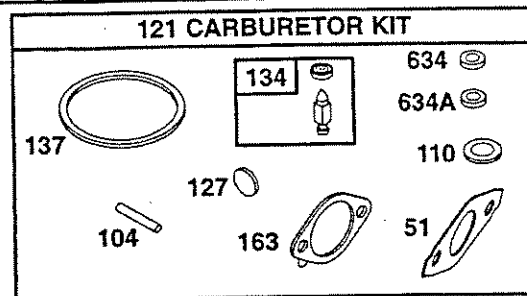
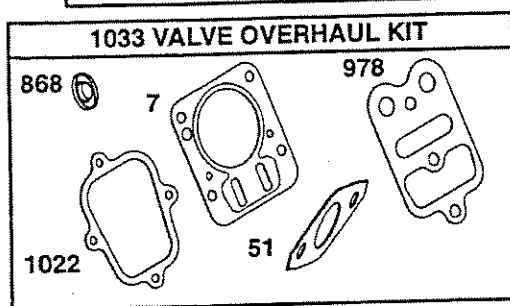
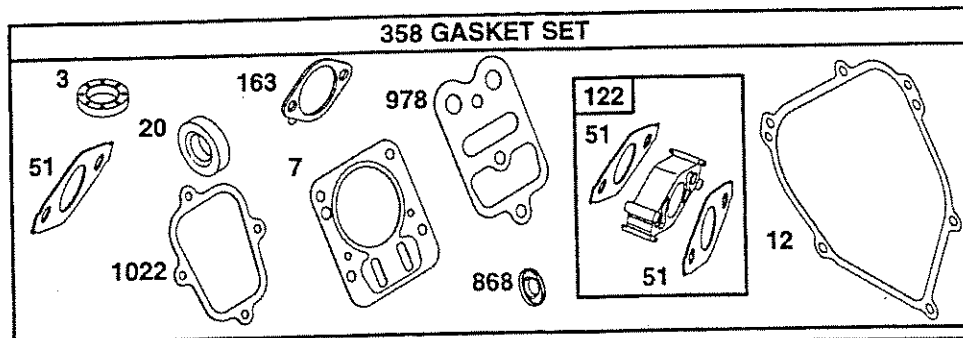

REF. NO.	PART NO.	DESCRIPTION	REF. NO.	PART NO.	DESCRIPTION	REF. NO.	PART NO.	DESCRIPTION
3	692266	Seal-Oil	127		Plug-Welch (Sold in Kit Only)	634A		Washer-Shaft Choke Shaft (Sold in Kit Only)
7	692554	Gasket-Cylinder Head	134	398188	Valve-Needle (Includes Seat)	868	692044	Seal-Valve
12	692549	Gasket-Crankcase	137		Gasket-Float Bowl (Sold in Kit Only)	977	690033	Gasket Set-Carburetor
20	692550	Seal-Oil	163	691887	Gasket-Air Cleaner	978	691892	Gasket-Plate
51	692555	Gasket-Intake (2 Required)	358	690031	Gasket Set	1022	691890	Gasket-Rocker Cover
104	691242	Pin-Float Hinge	634		Washer-Shaft (Throttle Shaft) (Sold in Kit Only)	1033	690034	Kit-Valve Overhaul
110		Washer-Seal (Sold in Kit Only)						
121	690032	Carburetor Kit						
122	690043	Spacer-Carburetor						

Briggs & Stratton welcomes warranty repair and apologizes to you for being inconvenienced. Any Authorized Service Dealer may perform warranty repairs. Most warranty repairs are handled routinely, but sometimes requests for warranty service may not be appropriate. For example, warranty would not apply if engine damage occurred because of misuse, lack of routine maintenance, shipping, handling, warehousing or improper installation. Similarly, warranty is void if the serial number of the engine has been removed or the engine has been altered or modified.

If a customer differs with the decision of the Service-Dealer, an investigation will be made to determine whether the warranty applies. Ask the Service Dealer to submit all supporting facts to his Distributor or the Factory for review. If the Distributor or the Factory decides that the claim is justified, the customer will be fully reimbursed for those items that are defective. To avoid misunderstanding which might occur between the customer and the Dealer, listed below are some of the causes of engine failure that the warranty does not cover.

Improper maintenance:

The life of an engine depends upon the conditions under which it operates, and the care it receives. Some applications, such as tillers, pumps and rotary mowers, are very often used in dusty or dirty conditions, which can cause what appears to be premature wear. Such wear, when caused by dirt, dust, spark plug cleaning grit, or other abrasive material that has entered the engine because of improper maintenance, is not covered by warranty.

This warranty covers engine related defective material and/or workmanship only, and not replacement or refund of the equipment to which the engine may be mounted. Nor does the warranty extend to repairs required because of:

1. PROBLEMS CAUSED BY PARTS THAT ARE NOT ORIGINAL BRIGGS & STRATTON PARTS.
2. Equipment controls or installations that prevent starting, cause unsatisfactory engine performance, or shorten engine life. (Contact equipment manufacturer.)
3. Leaking carburetors, clogged fuel pipes, sticking valves, or other damage, caused by using contaminated or stale fuel. (Use clean, fresh, lead-free gasoline and Briggs & Stratton gasoline stabilizer, Part No. 5041.)
4. Parts which are scored or broken because an engine was operated with insufficient or contaminated lubricating oil, or an incorrect grade of lubricating oil (check oil level daily or after every 8 hours of operation. Refill when necessary and change at recommended intervals.) Read "Owner's Manual."
5. Repair or adjustment of associated parts or assemblies such as clutches, transmissions, remote controls, etc., which are not manufactured by Briggs & Stratton.
6. Damage or wear to parts caused by dirt, which entered the engine because of improper air cleaner maintenance, re-assembly, or use of a non-original air cleaner element or cartridge. (At recommended intervals, clean and re-oil the Oil-Foam® element or the foam pre-cleaner, and replace the cartridge.) Read "Owner's Manual."
7. Parts damaged by overspeeding, or overheating caused by grass, debris, or dirt, which plugs or clogs the cooling fins, or flywheel area, or damage caused by operating the engine in a confined area without sufficient ventilation. (Clean fins on the cylinder, cylinder head and flywheel at recommended intervals.) Read "Owner's Manual."
8. Engine or equipment parts broken by excessive vibration caused by a loose engine mounting, loose cutter blades, unbalanced blades or loose or unbalanced impellers, improper attachment of equipment to engine crankshaft, overspeeding or other abuse in operation.
9. A bent or broken crankshaft, caused by striking a solid object with the cutter blade of a rotary lawn mower, or excessive v-belt tightness.
10. Routine tune-up or adjustment of the engine.
11. Engine or engine component failure, i.e., combustion chamber, valves, valve seats, valve guides, or burned starter motor windings, caused by the use of alternate fuels such as, liquified petroleum, natural gas, altered gasolines, etc.

INV300-02 Material Status Inquiry VDEV88 11/03/98
 Item 919-76902 & PRESSURE WASHER 2600PSI 2.7GPM LD9971 11:20:38
 Group U/M sales EA Purch EA Stock EA Rev # On hand .00
 Class NC ABC code C Yield pct 100.00 Cust. alloc .00
 Type 3 PURCH PART Draw/Formula # NO DWG Mfg. alloc .00
 FG Only 0 Loaded 0 Balance 0 On order .00
 Available .00
 MTD YTD Weight/Unit .000
 Opening Balance .00 Lot Size Std. 1.00
 Issues .00 Std Batch Size 1.00
 Receipts .00 Dly Lead Time Rate
 Adjustments .00 Fixed Lead Time Days 3
 Sales Units .00 Variable Lead Time
 Sales Amt .00 Order Policy J MULT LOTSZE
 List/Catalog Horizon Days
 List Price Period Order Days
 Std. Cost MRP/MPS code Buyer code X
 Actual Cst Vendors Vendors Item #
 Discount Code
 Purch U/M cnv 1.000 Planner Code P
 Sales U/M cnv 1.000
 Minimum Balance
 CMD/1-End CMD/2-New Item CMD/5-Orders CMD/7-Whs CMD/18-Hist CMD/19-Locs HELI
 CMD/9-Open vs. On-Hand CMD/3 ITEM EXT CMD/6 FPA INQUIRY CMD/11-Sales Hist.

Free Manuals Download Website

<http://myh66.com>

<http://usermanuals.us>

<http://www.somanuals.com>

<http://www.4manuals.cc>

<http://www.manual-lib.com>

<http://www.404manual.com>

<http://www.luxmanual.com>

<http://aubethermostatmanual.com>

Golf course search by state

<http://golfingnear.com>

Email search by domain

<http://emailbydomain.com>

Auto manuals search

<http://auto.somanuals.com>

TV manuals search

<http://tv.somanuals.com>