

Owner's Manual

CRAFTSMAN®



48" SNOW BLADE

Model No. 486.244283

DO NOT RETURN TO STORE
For Missing Parts or Assembly
Questions Call 1-866-576-8388

Most fasteners are readily available
through any hardware store

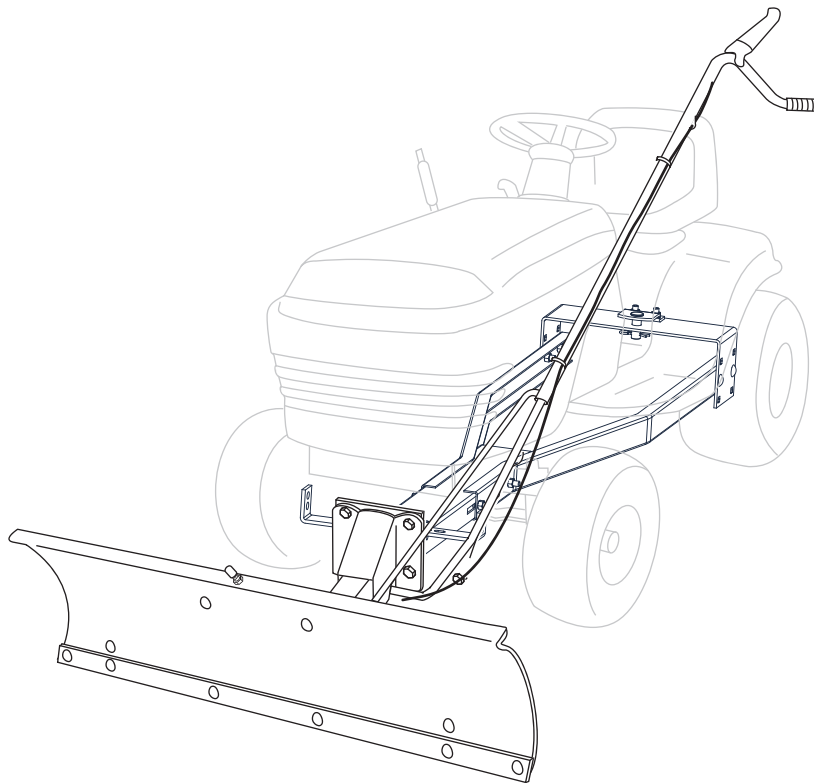

CAUTION:

Before using this product, read
this manual and follow all Safety
Rules and Operating Instructions.

- Safety
- Assembly
- Operation
- Maintenance
- Parts

Sears, Roebuck and Co., Hoffman Estates, IL 60179 U.S.A.
www.sears.com/craftsman

PRINTED IN U.S.A.

FORM NO. 49828 (1/06)

TABLE OF CONTENTS

SAFETY RULES.....	2	MAINTENANCE	15
WARRANTY	3	SERVICE AND ADJUSTMENTS.....	16
ACCESSORIES.....	3	STORAGE	16
FULL SIZE HARDWARE CHART	4	TROUBLESHOOTING.....	16
CARTON CONTENTS.....	5	REPAIR PARTS ILLUSTRATION.....	18
ASSEMBLY.....	6-13	REPAIR PARTS LIST	19
OPERATION.....	14-15	PARTS ORDERING/SERVICE	BACK COVER



SAFETY



Any power equipment can cause injury if operated improperly or if the user does not understand how to operate the equipment. Exercise caution at all times, when using power equipment.

1. Read the tractor and snow blade owner's manuals and know how to operate your tractor before using tractor with snow blade attachment.
2. Never operate tractor and snow blade without wearing proper clothing suited to weather conditions and operation of controls.
3. Never allow children to operate tractor and snow blade, and do not allow adults to operate without proper instructions.
4. Always begin with transmission in first (low) gear and gradually increase speed as required.



Look for this symbol to point out important safety precautions. It means--**Attention!! Become alert!! Your safety is involved.**

The model number and serial numbers will be found on a decal attached to the snow blade.

You should record both the serial number and the date of purchase and keep in a safe place for future reference.

MODEL NUMBER: 486.244283

SERIAL NUMBER: _____

DATE OF PURCHASE: _____

WARRANTY

ONE YEAR FULL WARRANTY

When operated and maintained according to the instructions supplied with it, if this Snow Blade fails due to a defect in material or workmanship within one year from the date of purchase, call 1-800-4-MY-HOME® to arrange for free repair (or replacement if repair proves impossible).

If this product is used for commercial or rental purposes, this warranty applies for only 90 days from the date of purchase.

This warranty gives you specific legal rights, and you may also have other rights which vary from state to state.

Sears, Roebuck and Co., D817WA, Hoffman Estates, IL 60179

ACCESSORIES AND ATTACHMENTS

These and other accessories are recommended for use with your unit. Call 1-800-4-MY-HOME® to find out if they are available. If available, they may be purchased at most Craftsman outlets or by calling 1-800-4-MY-HOME®.

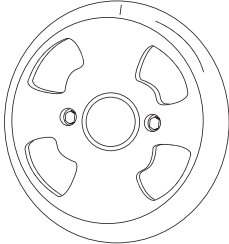
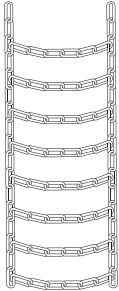
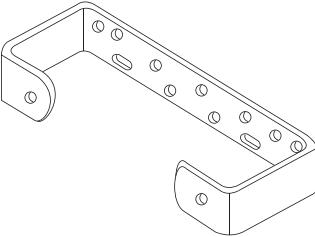
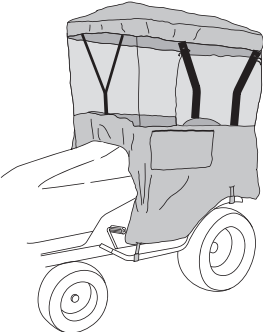
WHEEL WEIGHT	TIRE CHAINS	WEIGHT BRACKET FOR DRAW BAR	SNOW CAB
			

HARDWARE PACKAGE CONTENTS

(SHOWN FULL SIZE)

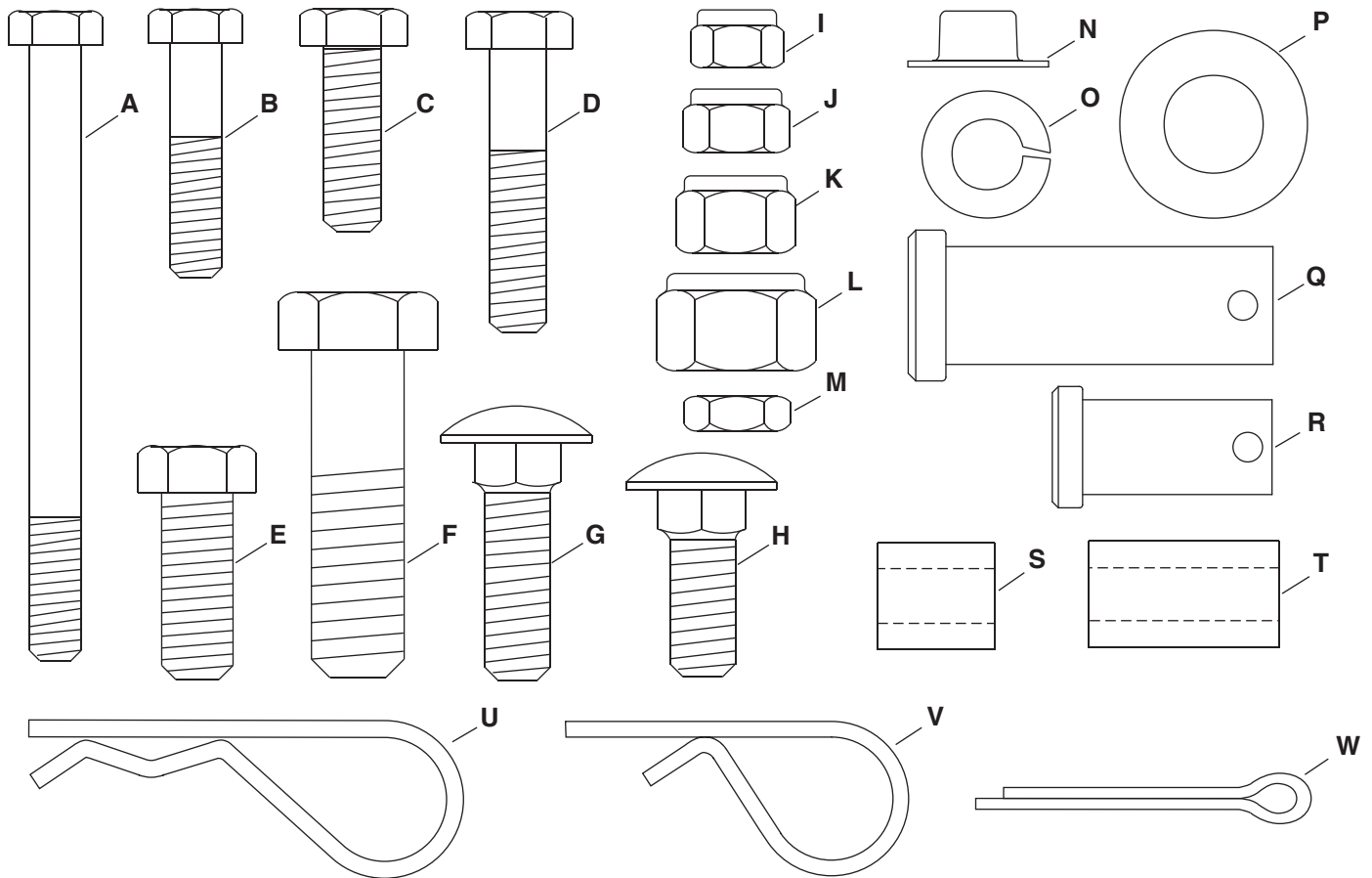

REF.	QTY.	DESCRIPTION	REF.	QTY.	DESCRIPTION
A	1	Hex Bolt, 1/4" x 3-1/4" LG.	L	1	Nylock Nut, 1/2"
B	1	Hex Bolt 1/4" x 1-1/4"	M	4	Hex Jam Nut, 5/16"
C	4	Hex Bolt, 5/16" x 1"	N	2	Palnut, 3/8"
D	1	Hex Bolt, 5/16" x 1-1/2"	O	2	Lock Washer, 3/8"
E	2	Hex Bolt, 3/8" x 1"	P	3	Washer 1/2"
F	1	Hex Bolt, 1/2" x 1-3/4"	Q	1	Clevis Pin, 5/8" x 1-3/4"
G	4	Carriage Bolt 3/8" x 1-1/4"	R	2	Clevis Pin, 1/2" x 1"
H	18	Carriage Bolt, 3/8" x 1"	S	1	Spacer, 5/8" LG.
I	3	Nylock Nut, 1/4"	T	2	Spacer, 1" LG.
J	5	Nylock Nut, 5/16"	U	3	Hairpin Cotter, Large
K	22	Nylock Nut, 3/8"	V	4	Hairpin Cotter, Small
			W	2	Cotter Pin 1/8" x 1-1/4"

PARTS IN HARDWARE PACKAGES NOT SHOWN FULL SIZE

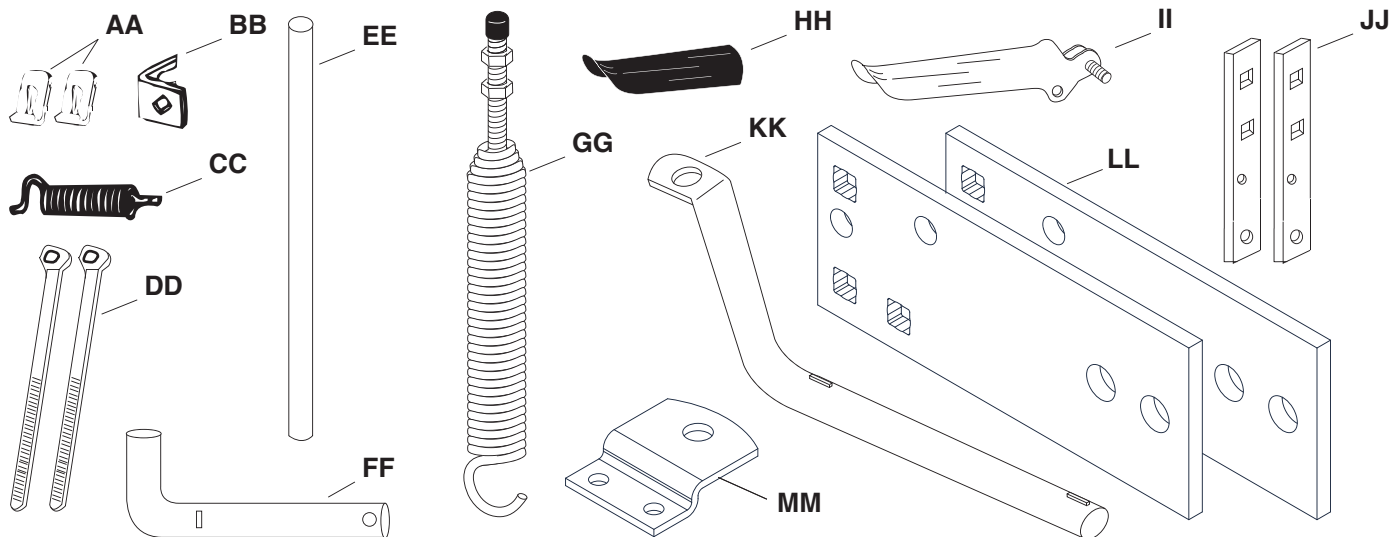

REF.	QTY.	DESCRIPTION	REF.	QTY.	DESCRIPTION
AA	2	Cable End Fitting	GG	1	Blade Adjust Spring
BB	1	Cable Mount Bracket	HH	1	Plastic Grip
CC	1	Angle Lock Spring	II	1	Grip Assembly
DD	2	Nylon Tie	JJ	2	Angle Lock Bar
EE	1	Spring Mount Rod	KK	1	Blade Pivot Shaft
FF	1	Channel Pivot Pin	LL	2	Frame Bracket
			MM	1	Rear Locating Bracket

CARTON CONTENTS (Loose Parts in Carton)

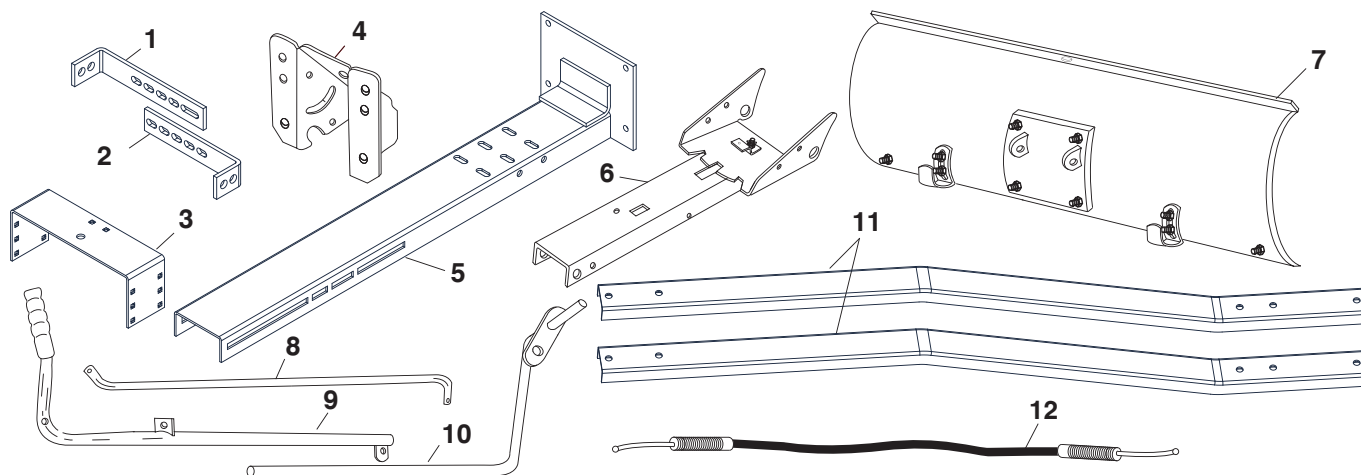

REF.	QTY.	DESCRIPTION	REF.	QTY.	DESCRIPTION
1	1	Long Hanger Bracket	7	1	Blade Assembly
2	1	Short Hanger Bracket	8	1	Blade Pivot Rod
3	1	Rear Mounting Bracket	9	1	Lift Handle Tube
4	1	Pivot Support Bracket	10	1	Lift Handle Rod
5	1	Thrust Channel	11	2	Rear Support Channel
6	1	Channel Assembly	12	1	Cable

OPERATION

TOOLS REQUIRED FOR ASSEMBLY

- (1) Pliers
- (1) Hammer
- (1) Adjustable Wrench (or socket set)
- (1) 9/16" Open End or Box End Wrench
- (2) 7/16" Open End or Box End Wrench
- (2) 1/2" Open End or Box End Wrench

REMOVAL OF PARTS FROM CARTON

- Remove the loose parts and the hardware packages from the carton. Lay out all parts and hardware and identify using the illustrations on pages 4 and 5.

IMPORTANT: You will not use all of the parts or hardware supplied with your blade. Dispose of unused parts or hardware after you have finished assembling the blade.



CAUTION: Do not begin assembling until the tractor engine, muffler and exhaust deflector have been allowed to cool off.

TRACTOR PREPARATION

- Allow engine, muffler and exhaust deflector to cool before beginning.
- Refer to tractor owner's manual to remove mower deck or any other attachment you may have mounted to your tractor. Mark and save all removed parts.

IMPORTANT: Right hand (R.H.) and left hand (L.H.) are determined from the operators position while seated on the tractor.

STEP 1: (SEE FIGURE 1)

- Look under the front of your tractor. If there is a single mower deck suspension bracket located underneath the middle of the front axle, continue on to step 2. If not, skip to step 7 on page 8 for tractors with dual mower deck suspension brackets.

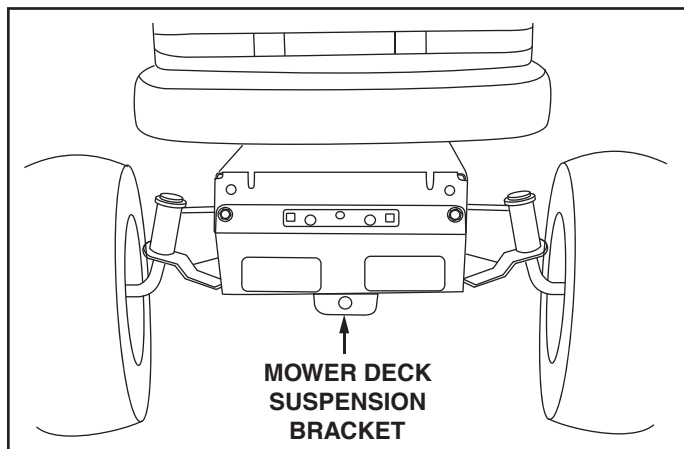

FIGURE 1 - SEARS TRACTOR SHOWN

INSTRUCTIONS FOR TRACTORS WITH SINGLE FRONT DECK SUSPENSION BRACKETS

STEP 2: (SEE FIGURE 2)

- Use figure 2 to help identify the mounting holes for Sears tractor frames. For other brand tractors, identify the two mounting holes by placing a frame bracket against the tractor frame **in front of** the front axle and finding two holes in the tractor frame that align with two of the holes in the frame bracket. The bracket can be flipped over to reverse the hole pattern. Refer also to the illustrations on page 9.
- Remove any bolts found in the mounting holes.
- On Sears tractors, remove the browning shield from the front of the tractor as shown.

IMPORTANT: Be sure to reattach the browning shield in step 3.

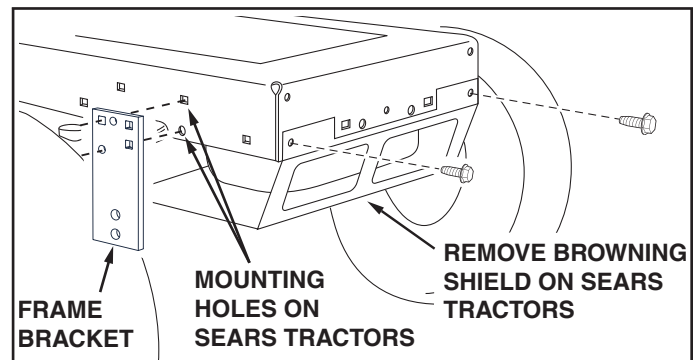

FIGURE 2 - SEARS TRACTOR SHOWN

STEP 3: (SEE FIGURE 3)

- Attach a frame bracket to each side of the tractor frame. On Sears tractors use a 3/8" x 1" hex bolt (E) and 3/8" lock washer (O) in the lower hole and a 3/8" x 1" carriage bolt (H) and 3/8" nylock nut (K) in the upper hole of each frame bracket. Leave out the upper bolt if there is no hole in the tractor frame. **Do not tighten.** For other brand tractors use the bolts and nuts shown in the illustrations on page 9.
- On Sears tractors re-attach the browning shield.

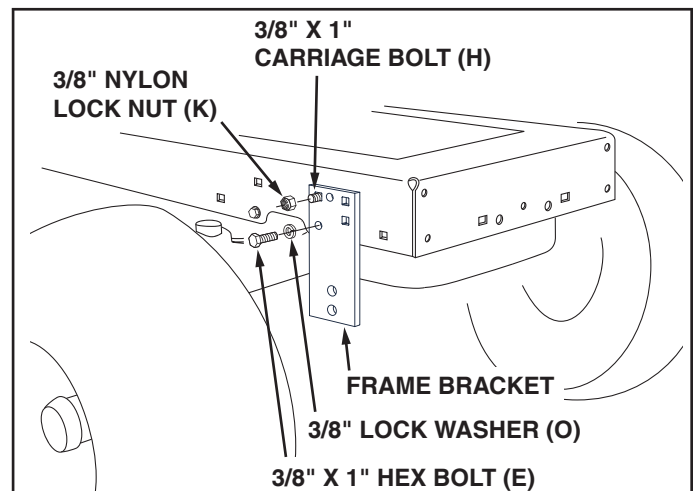

FIGURE 3 - SEARS TRACTOR SHOWN

STEP 4: (SEE FIGURE 4)

This step is for Sears tractors only. If you have a tractor brand other than Sears, skip to step 5.

- Stack the short Hanger Bracket on top of the long Hanger Bracket with the ends of the brackets pointing up. Align the first and third slots in both brackets with the middle set of slots in the thrust channel as shown.
- Fasten the brackets to the thrust channel using two 3/8" x 1-1/4" carriage bolts (G) and 3/8" nylock nuts (K). Spread the brackets so that the ends are approximately 12-1/4" apart, measured from the outside. **Do not tighten.**
- Skip to step 9 on page 10.

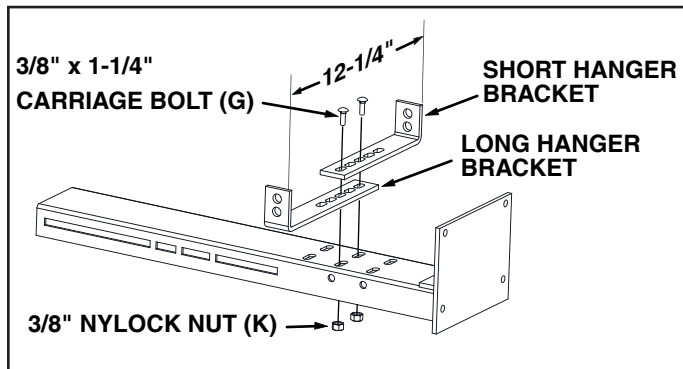

FIGURE 4 - SEARS TRACTOR SHOWN

STEP 5: (SEE FIGURE 5)

This step is for tractor brands other than Sears.

If you have a Sears tractor, skip to step 9 on page 10.

- Measure the distance from the center of the frame brackets to the front of the tractor frame. This will be referred to as distance "L" in step 6.
- Measure to determine which of the two holes at the bottom of the Frame Bracket is closest to being 6" from the ground. The height of this hole will be referred to as distance "H" in step 6.
- Measure the inside distance between the Frame Brackets. This distance will be referred to as distance "W" in step 6.

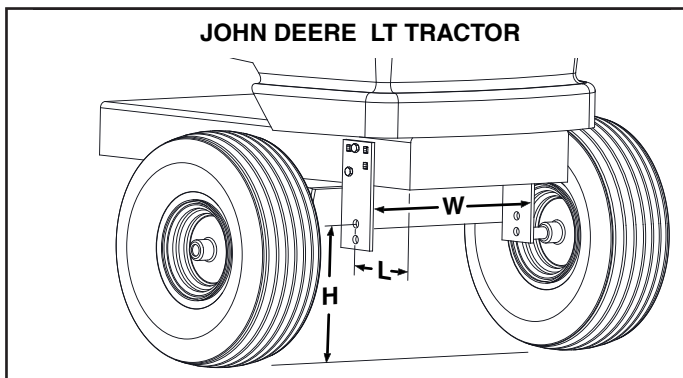

FIGURE 5 - JOHN DEERE TRACTOR LT SHOWN

STEP 6: (SEE FIGURE 6 AND THE ILLUSTRATIONS ON PAGE 9)

This step is for tractor brands other than Sears.

If you have a Sears tractor, skip to step 9 on page 10.

- Refer to the illustrations on page 9 for examples of how to attach the Hanger Brackets on various tractors.
- Select the set of slots in the top of the Thrust Channel that will position the channel's front plate slightly out in front of the tractor frame. The distance from the slots to the front plate must be slightly greater than the distance "L" in step 5.
- Hold the Hanger Brackets with the ends pointing up. Stack the short Hanger Bracket on top of the long Hanger Bracket. If distance "H" measured in step 5 was less than 6", hold the brackets together and flip them over so that the ends point down.
- Slide the Hanger Brackets apart so that the overall length is slightly less than distance "W" measured in step 5. Center the Hanger Brackets on top of the Thrust Channel and attach them to the selected slots using two 3/8" x 1-1/4" carriage bolts (G) and 3/8" nylock nuts (K). **Do not tighten.**
- Proceed to step 9 on page 10.

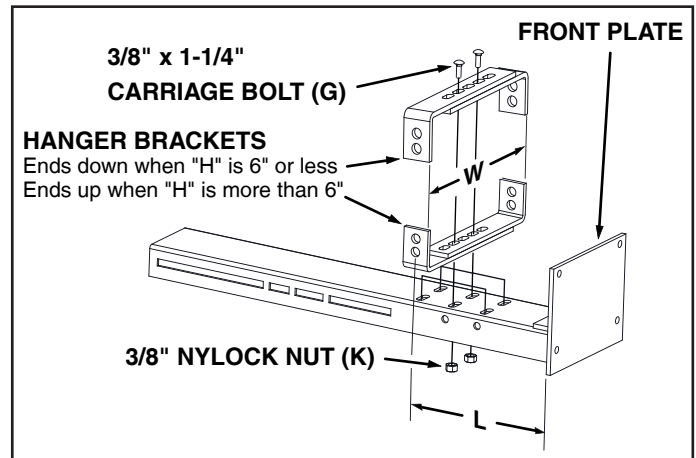

FIGURE 6

INSTRUCTIONS FOR TRACTORS WITH DUAL FRONT DECK SUSPENSION BRACKETS

STEP 7: (SEE FIGURE 7)

- Locate the Mower Deck Suspension Brackets on each side at the front of the tractor frame. A Sears tractor is shown below. For examples of brackets on other tractors see the illustrations on page 9.
- Measure the distance from the center of the deck attachment hole in the Mower Deck Suspension Brackets to the front of the tractor frame. This will be referred to as distance "L" in step 8.
- Measure the height above the ground of the deck attachment hole in the Mower Deck Suspension Brackets. The height of this hole will be referred to as distance "H" in step 8.
- Measure the inside distance between the Mower Deck Suspension Brackets. This will be referred to as distance "W" in step 8.

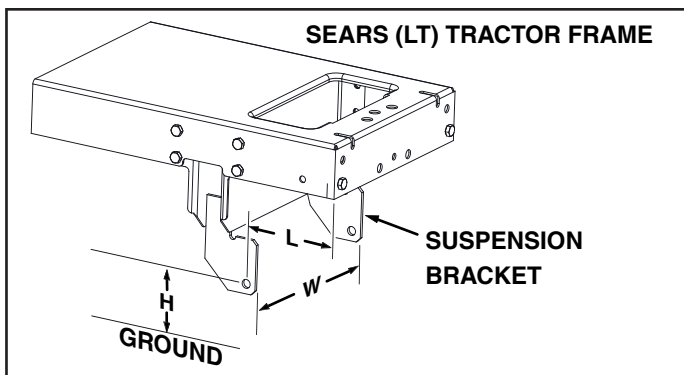

FIGURE 7 - SEARS TRACTOR SHOWN

STEP 8: (SEE FIGURE 8 AND THE ILLUSTRATIONS ON PAGE 9)

- Refer to the illustrations on page 9 for examples of how to attach the Hanger Brackets on various tractors.
- Select a set of slots in the top of the Thrust Channel that will position the front plate slightly out in front of the tractor frame. The distance from the slots to the front plate must be slightly greater than the distance "L" in step 7.
- Hold the Hanger Brackets with the ends pointing up. Stack the short Hanger Bracket on top of the long Hanger Bracket. If distance "H" measured in step 7 was less than 6", hold the brackets together and flip them over so that the ends point down.
- Slide the Hanger Brackets apart so that the overall length is slightly less than distance "W" measured in step 7. Center the Hanger Brackets on top of the Thrust Channel and attach them to the selected slots using two 3/8" x 1-1/4" carriage bolts (G) and 3/8" nylock nuts (K). **Do not tighten.**
- Proceed to step 9 on page 10.

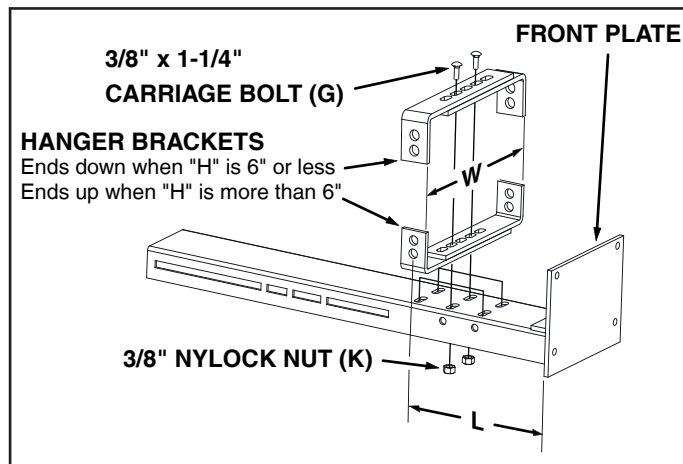
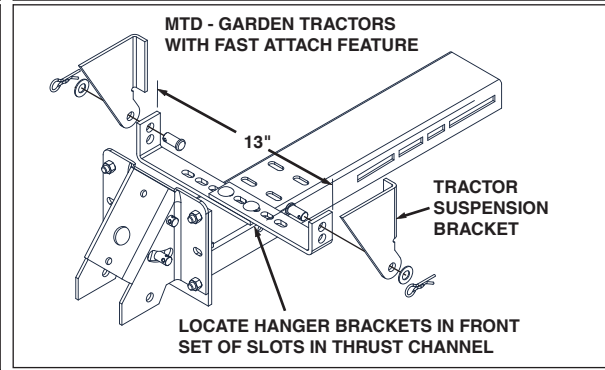
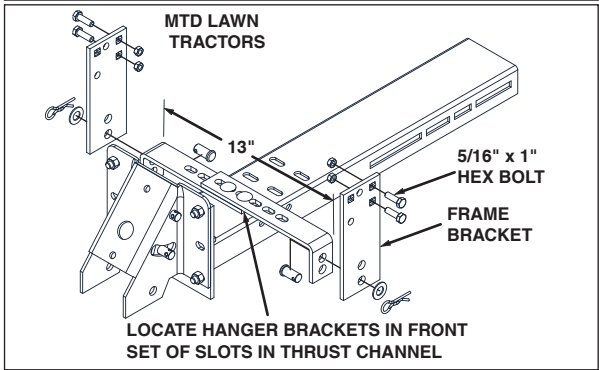
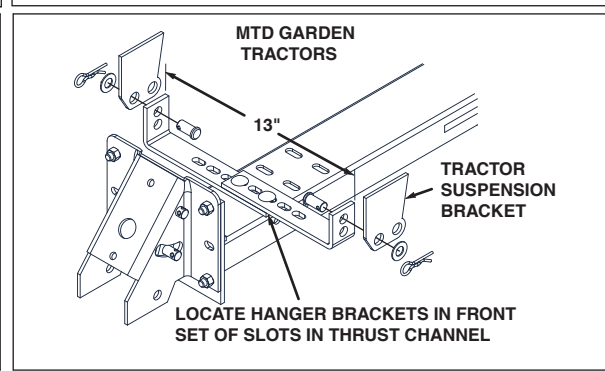
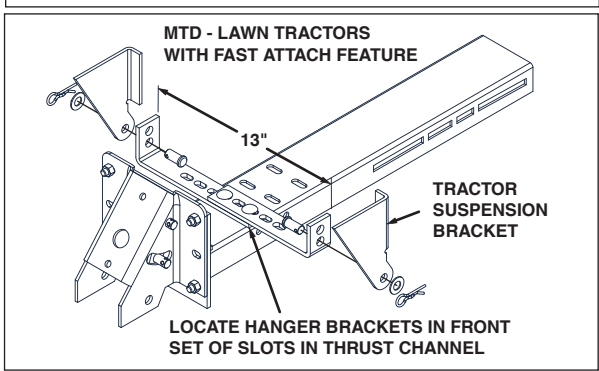
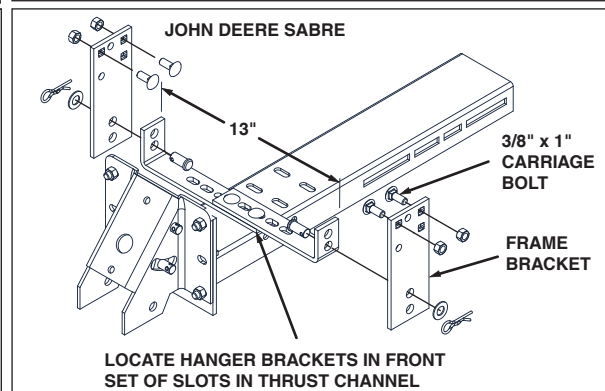
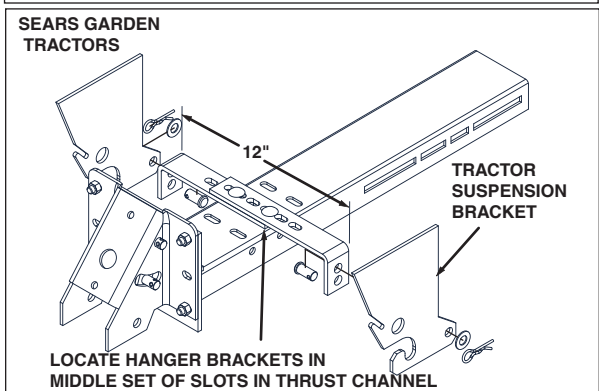
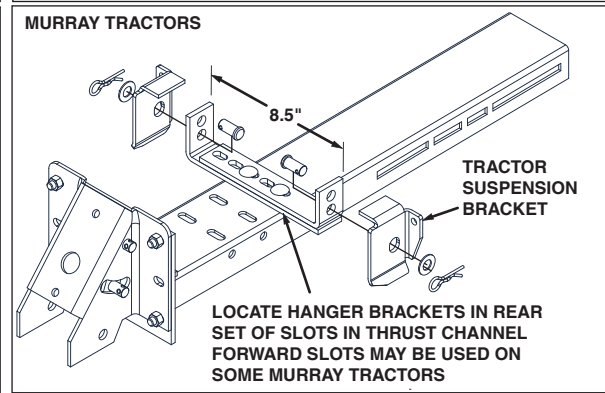
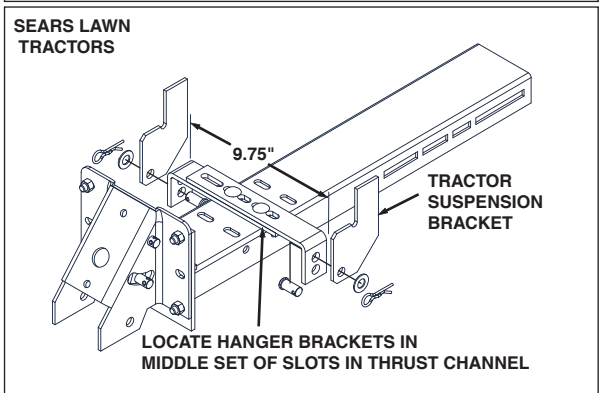
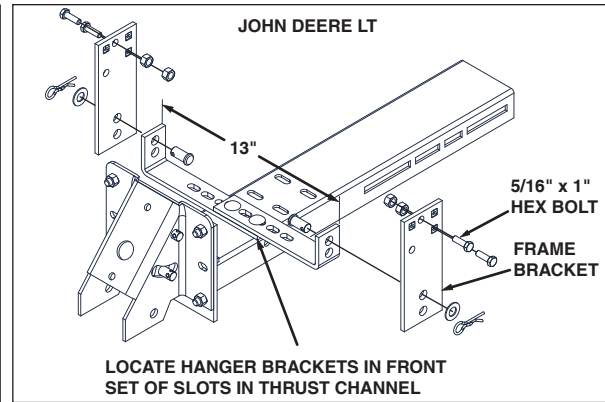
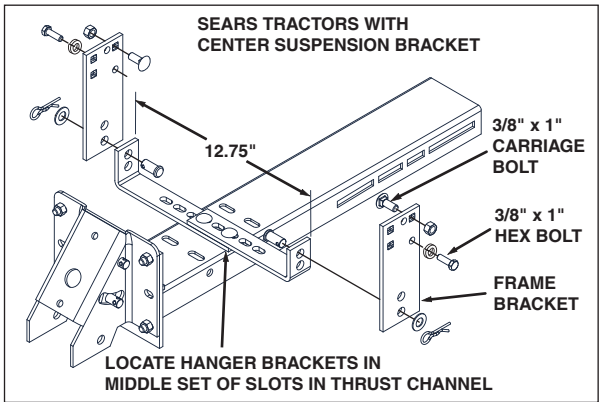

FIGURE 8



STEP 9: (SEE FIGURE 9)

- Install the Rear Locating Bracket to the top of the Rear Mounting Bracket using two 3/8" x 1" Carriage bolts (H) and 3/8" nylock nuts (K). **Tighten** nuts.
- Install the Rear Support Channels to the middle set of holes in the sides of the Rear Mounting Bracket using four 3/8" x 1" Carriage Bolts (H) and 3/8" nylock nuts (K). **Finger tighten only.**

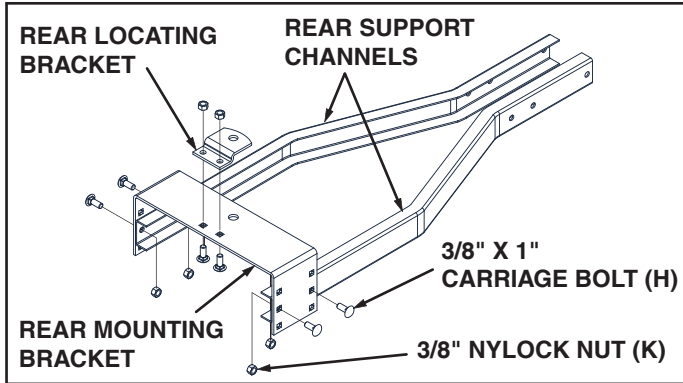

FIGURE 9

STEP 10: (SEE FIGURE 10)

- Slide the Rear Support Channels under the rear of the tractor. Attach the Rear Mounting Bracket to the Tractor Drawbar using the 5/8" x 1-3/4" Clevis Pin (Q) and a large Hairpin Cotter (U).

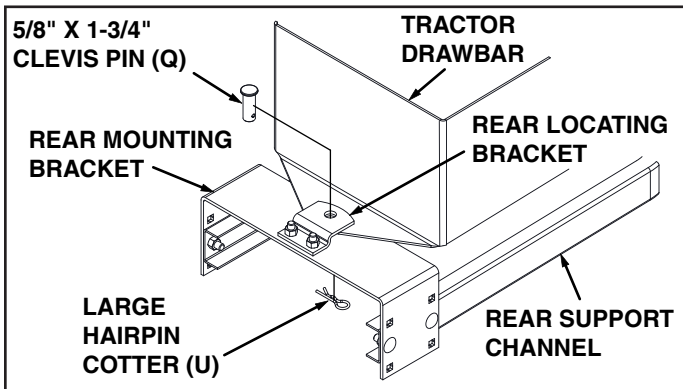

FIGURE 10

STEP 11: (SEE FIGURE 11)

- Slide the Thrust Channel under the front of the tractor. Attach the Hanger Brackets to the Frame Brackets using two 1/2" x 1" clevis pins (R), 1/2" washers (P) and large hairpin cotters (U).

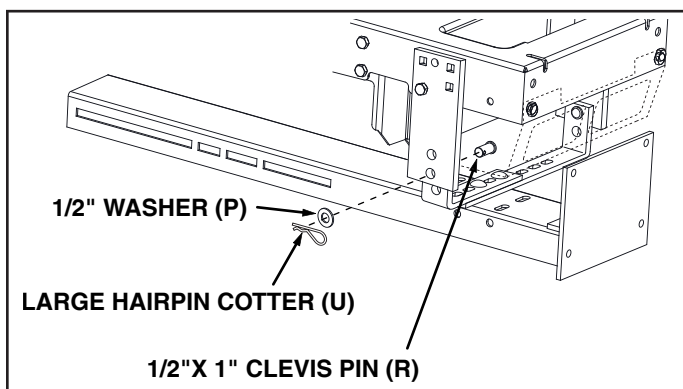

FIGURE 11 - SEARS TRACTOR SHOWN

STEP 12: (SEE FIGURE 12)

- Place the rear of the Thrust Channel between the two Rear Support Channels. Install four 3/8" x 1" carriage bolts (H) and 3/8" nylock nuts (K) using the most widely spaced holes that are aligned with slots. **Finger tighten only.**
- If the Rear Support Channels bump against bottom of the tractor, reattach the rear of the channels to a lower set of holes in the Rear Mounting Bracket. If there is more clearance than necessary between the Rear Support Channels and the bottom of the tractor, reattach the rear of the channels to a higher set of holes in the Rear Mounting Bracket.
- Spread the Hanger Brackets apart as far as possible and center the Thrust Channel under the tractor.
- **Tighten** all bolts and nuts installed up to this point.
- Measure the height of the front plate on the Thrust Channel. If it is not 4" to 5" above the ground, reinstall the clevis pins in the Hanger Brackets to a higher or lower hole position to attain the correct height.

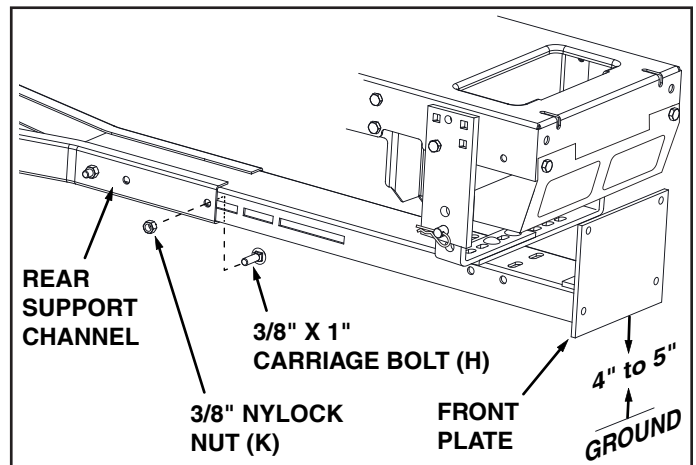

FIGURE 12 - SEARS TRACTOR SHOWN

STEP 13: (SEE FIGURE 13)

- Assemble the pivot support bracket to the front of the Thrust Channel using four 3/8" x 1" carriage bolts (H) and four 3/8" nylock nuts (K). Make sure the bracket is straight and then **tighten**.

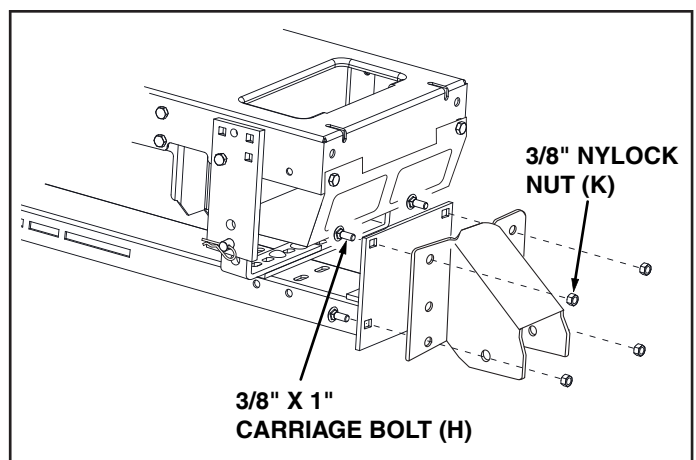

FIGURE 13 - SEARS TRACTOR SHOWN

STEP 14: (SEE FIGURE 14)

- Place the two angle lock bars together so that all holes are aligned. Assemble a 3/8" x 1-1/4" carriage bolt (G) and a 3/8" nylock nut (K) in the top hole. Be sure to insert bolt from side indicated. **Finger tighten only.**
- Insert the round hook end of the angle lock spring up through the hole in bracket (A).
- Hold the angle lock bars so that the square holes are at the top. Insert the straight hook end of the angle lock spring through the middle hole in both angle lock bars as shown.
- Insert the angle lock bars down through the slot in the channel. Under the channel, place a 1" long spacer (T) on each side of the angle lock bars and insert a 1/4" x 3-1/4" bolt (A) through the channel, the angle lock bars and the spacers. Secure the bolt with a 1/4" nylock nut (I). **Tighten** so that lock bars can pivot freely.
- At this time **tighten** the 3/8" carriage bolt and nylon lock nut previously assembled to angle lock bars.

NOTE: When the angle lock bars are pulled back, the pivot plate should unlock and be free to pivot.

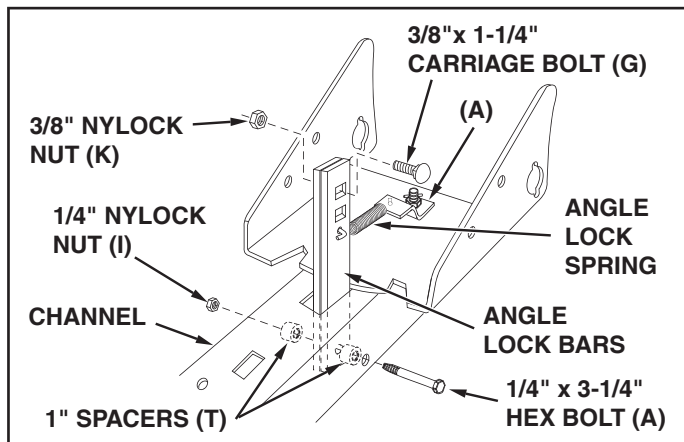

FIGURE 14 (Right Hand Side View)

STEP 15: (SEE FIGURE 15)

- Use a hammer to tap a 3/8" palnut (N) onto one end of the spring mount rod. Insert the rod through the rear set of holes in the pivot plate. Support the assembled end of the spring mount rod on a block of wood, and tap the remaining 3/8" palnut (N) onto the other end of the rod.

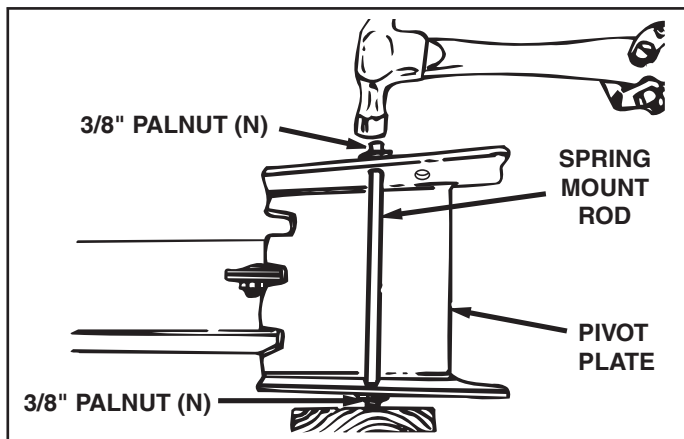

FIGURE 15 (Top View)

STEP 16: (SEE FIGURE 16)

- Assemble a 3/8" x 1-1/4" carriage bolt (G) through the square hole in the cable mount bracket and through the square hole in the angle lock bars as shown. (The carriage bolts should face in opposite directions.) Using pliers hold the cable mount bracket in position, angling down towards the L.H. hole in the channel as shown. Secure with a 3/8" nylock nut (K). **Tighten.** Refer also to figure 17 for the correct angle for the cable mount bracket.

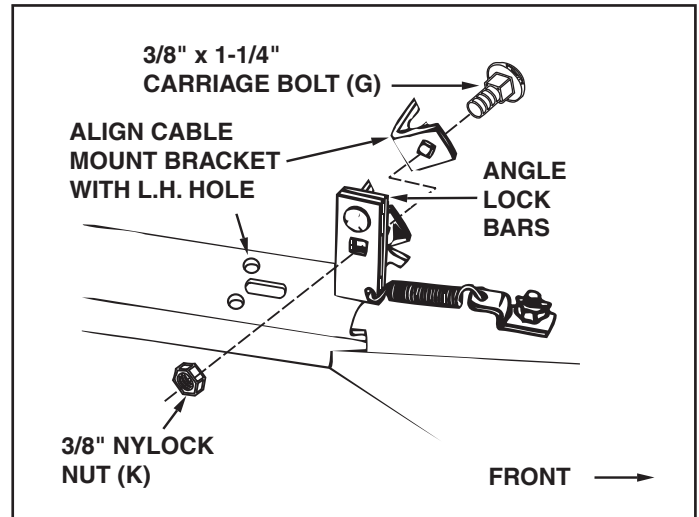

FIGURE 16 (Right Hand Side View)

STEP 17: (SEE FIGURE 17)

- Assemble one 5/16" jam nut (M) approximately 3/4" onto the threaded end of the control cable. Assemble the threaded cable end through the round hole in the cable mount bracket as shown and secure with another 5/16" jam nut (M). **Tighten.**

NOTE: Some adjustment of jam nuts may be required after blade assembly is completed.

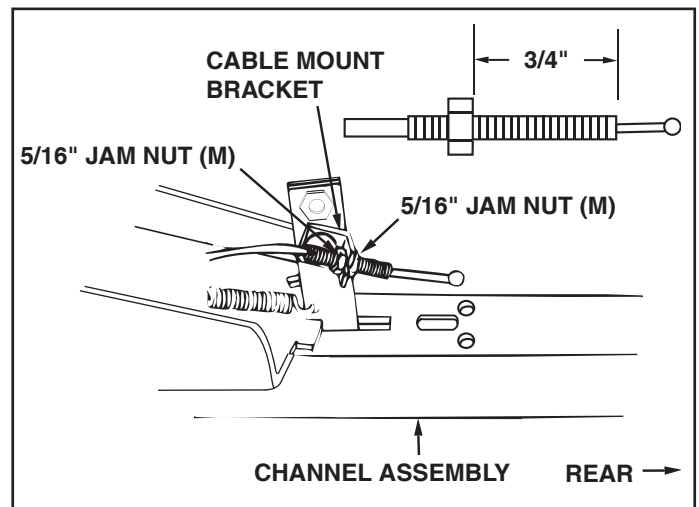

FIGURE 17 (Left Hand Side View)

STEP 18: (SEE FIGURE 18)

- Assemble ball end of control cable up through hole in cable end fitting and pull until ball slips inside curled edge of fitting as shown. If ball won't slip under edge of curl it will need to be inserted through open end of curl.
- Assemble 1/4" x 1-1/4" hex bolt (B) down through the cable end fitting, the 5/8" long spacer (S) and the left hand hole in the channel assembly. Secure with a 1/4" nylock nut (I). **Tighten.**

NOTE: Make sure the cable mount bracket is aligned with the cable end fitting as shown to prevent binding of cable. The other end of the control cable will be attached in a later step.

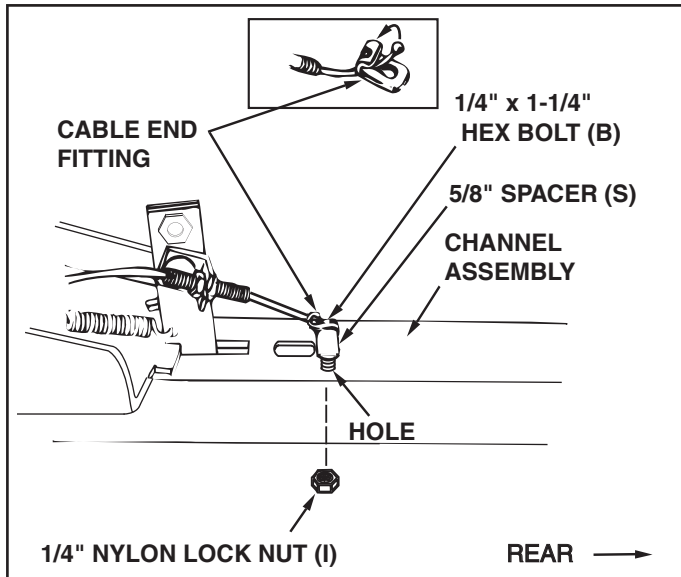

FIGURE 18 (Left Hand Side View)

STEP 19: (SEE FIGURE 19)

- To attach the blade to the channel assembly, align the notched holes in the pivot plate with the notched holes in the blade. Insert a 1/8" x 1-1/4" cotter pin (W) down through the hole at the bend in the blade pivot shaft. Spread the ends of the pin. From the left side insert the blade pivot shaft, bend facing up, through the notched holes. Secure the shaft with another 1/8" x 1-1/4" cotter pin (W) through the end hole in the shaft. Spread the ends of the pin.
- Remove the plastic cap and one 3/8" hex nut from the bolt in the blade adjust spring. Adjust the remaining 3/8" hex nut down approximately 1" onto the bolt threads. Hook the spring over the spring mount rod as shown. Place the bolt up through the hole in the top edge of the blade and reassemble the other 3/8" hex nut and tighten down against the top edge of the blade. Replace the plastic cap over the end of the bolt threads.

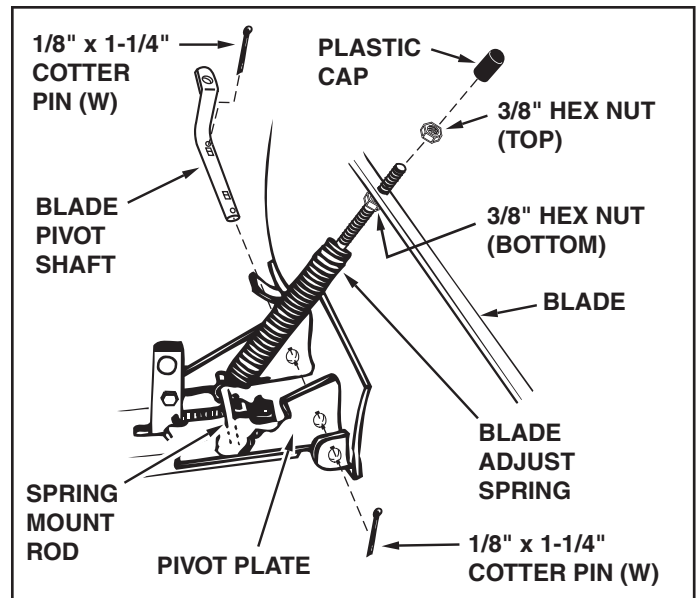

FIGURE 19 (Right Hand Side View)

STEP 20: (SEE FIGURE 20)

- Assemble the 1/2" washer (P) onto the channel pivot pin.
- Attach the channel assembly to the tractor by placing the end of the channel assembly up inside the pivot support bracket on the tractor. Align the hole in the pivot support bracket with the **second hole** in the channel assembly. Insert the channel pivot pin through the aligned holes from the left side and secure with a small hairpin cotter (V) pushed all the way through to the loop end.

NOTE: All hairpin cotters on this snow blade should be pushed through to their loop end.

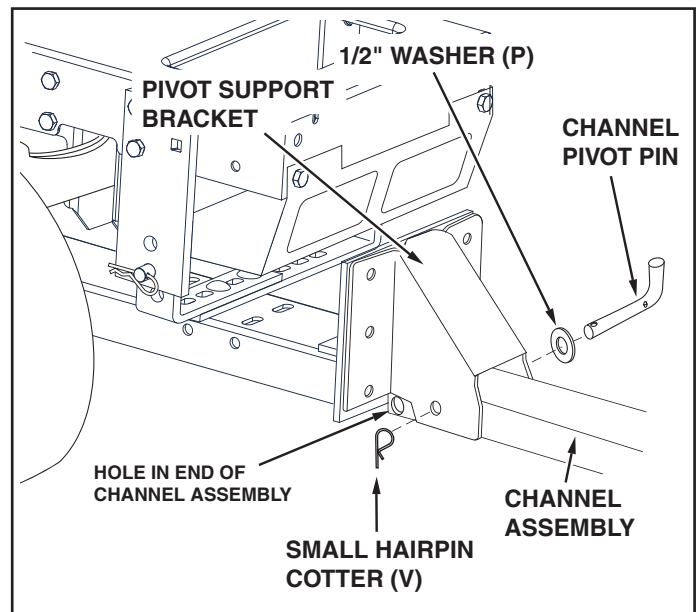

FIGURE 20 (Right Hand Side View)

STEP 21: (SEE FIGURE 21)

- From the left side, insert the welded end of the lift handle rod through the exposed holes in the end of the channel assembly. Next, insert the lift link pin through the hole in the bracket that is welded to the lift handle rod. (The lift link is pre-assembled to the pivot support bracket). Secure the bracket with a small hairpin cotter (V) inserted up through the lift link pin all the way to the loop end of the hair pin cotter.
- Using the furnished grease packet, apply a light coating of grease to the straight upper portion of the lift handle rod. Slide the lift handle tube onto the rod.

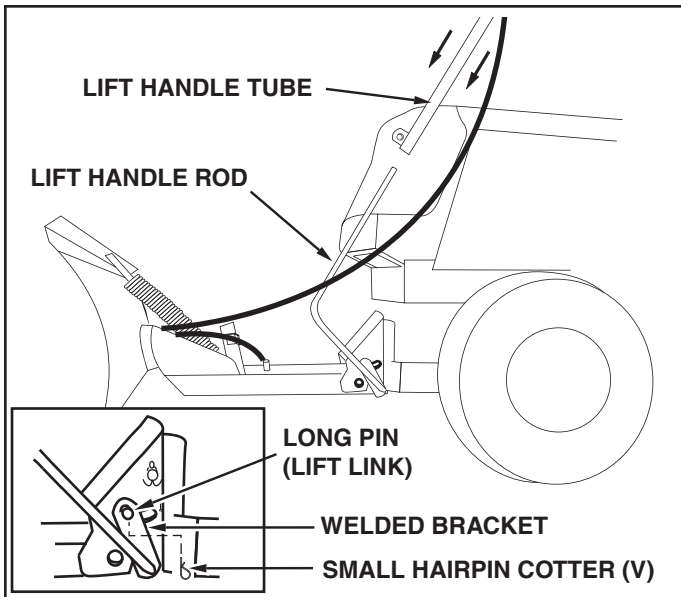

FIGURE 21 (Left Hand Side View)

STEP 22: (SEE FIGURE 20)

- Screw one 5/16" jam nut (M) approximately 3/4" onto the loose end of the control cable. Pass the cable around the outside of the lift handle rod and insert the threaded cable end through the cable mount bracket on the lift handle tube. Secure the cable with another 5/16" jam nut (M). **Tighten.**

NOTE: Some adjustment of jam nuts may be required after blade assembly is completed.

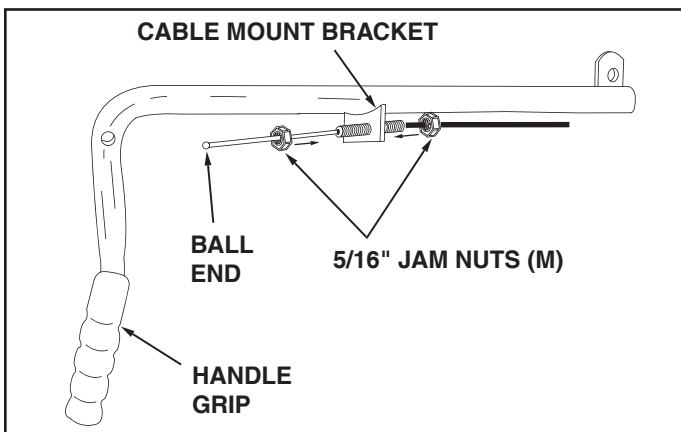

FIGURE 22 (Right Hand Side View)

STEP 23: (SEE FIGURE 23)

- Assemble the plastic grip onto the lock release grip assembly.
- Attach the lock release grip assembly to the lift handle tube using one 5/16" x 1-1/2" hex bolt (D) and one 5/16" nylock nut (J). **Do not overtighten** the nylon lock nut. The grip assembly must pivot freely.
- Assemble the ball end of the cable to a cable end fitting as was done to the other end of the cable. Secure the cable end fitting to the weld bolt on the lock release grip with a 1/4" nylock nut (I). **Do not overtighten** the nylon lock nut. The cable fitting must pivot freely.

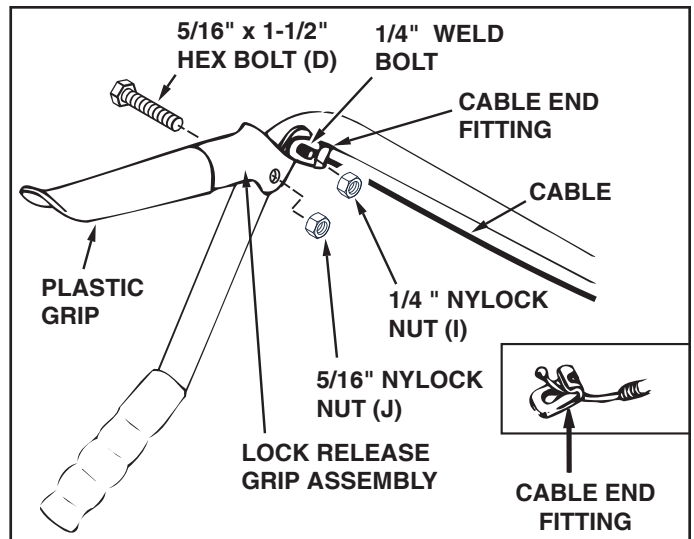

FIGURE 23 (Right Hand Side View)

STEP 24: (SEE FIGURE 24)

- Place the long end of the blade pivot rod down through the blade pivot shaft. Attach the short end of the blade pivot rod to the lift handle tube. Secure both ends with small hairpin cotters (V).
- Use the two plastic ties to hold the cable securely to the outside of the handle tube and away from the tractor to avoid direct heat from the tractor muffler.

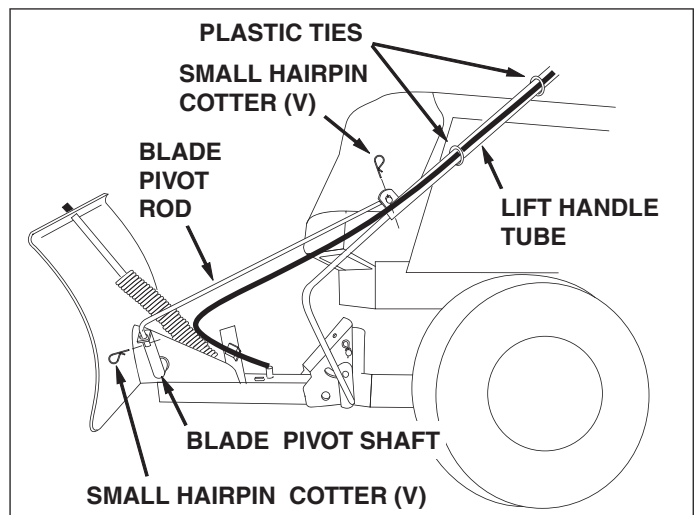

FIGURE 24 (Left Hand Side View)

OPERATION

KNOW YOUR SNOW BLADE

Read this owner's manual and safety rules before operating your snowblade.

Compare the illustration below with your snow blade to familiarize yourself with the various controls and their locations.

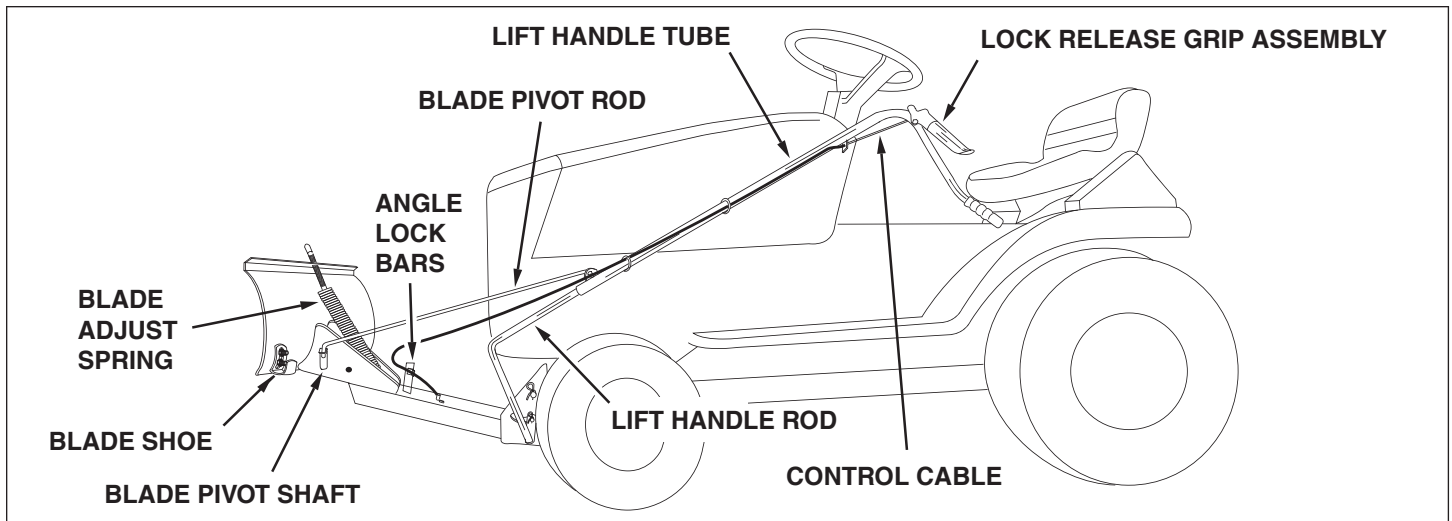

LOCK RELEASE GRIP ASS'Y.

Unlocks the blade to swivel to the right and left.

LIFT HANDLE TUBE

Raises or lowers the blade and pivots blade to the right and left.

BLADE PIVOT ROD

Connects blade to handle tube. Pivots blade to the right and left.

ANGLE LOCK BARS

Locks the blade in either the right hand, left hand or straight ahead position.

BLADE ADJUST SPRING

Holds blade in position but permits it to pivot forward to pass over an obstruction.

BLADE SHOE

Ground-contacting part of blade. Adjusts for adequate ground clearance of blade.

BLADE PIVOT SHAFT

Connects blade to channel assembly. Allows blade to pivot forward.

LIFT HANDLE ROD

Connects lift handle tube to channel assembly. Raises and lowers the blade.

CONTROL CABLE

Connects the lock release lever to the angle lock bars.

HOW TO USE YOUR SNOW BLADE

To Raise or Lower the Snow Blade

- Use the handle grip located on the end of the handle tube. To raise the blade, pull back while pushing down on the handle grip. To lower blade, pull back while lifting up on handle grip. See figure 25.

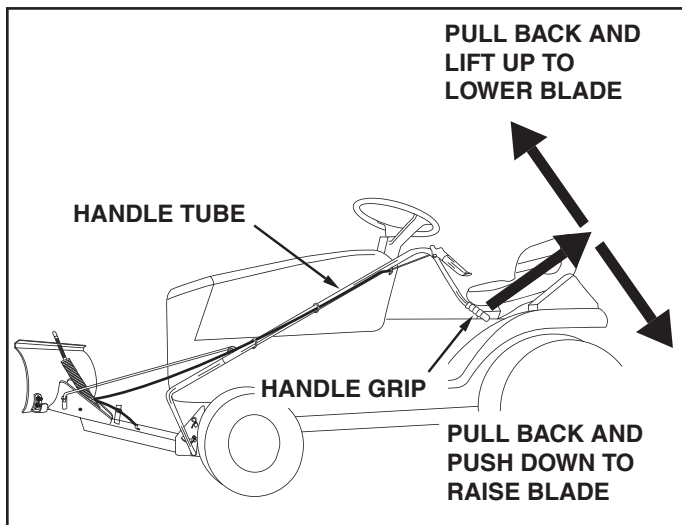

FIGURE 25

To Pivot the Blade

- Raise the blade to transport position. To unlock the blade, push the lock release grip down against the handle tube. To pivot the blade, keep the grip depressed and push forward or pull back on the handle tube, sliding it along the lift rod. Release the grip to lock the blade when it is in either the right hand, the left hand or the straight ahead position. See figure 26.

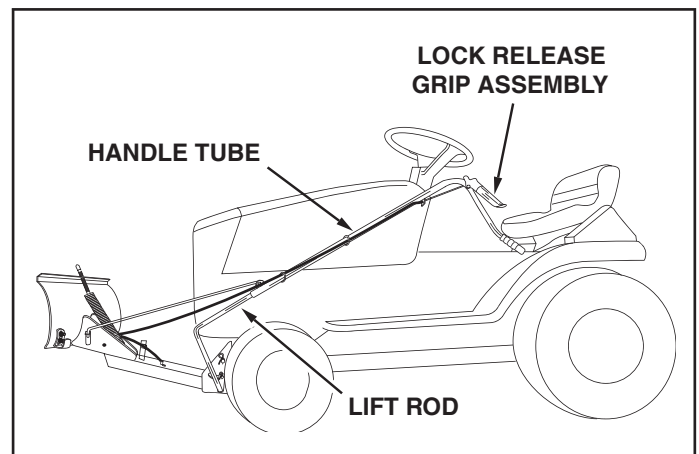

FIGURE 26

Using the Snowblade

Wheel weights and tire chains must be used with your snow blade for traction. These accessories are available at your nearest Sears retail store. See page 3.

- Prepare the lawn tractor engine for cold weather using instructions furnished with the lawn tractor.
- Always begin with the transmission in first (low) gear and gradually increase speed as required.
- **Do not** repeatedly push snow in the same direction, causing excessive build up with each successive pass.
- To reduce icing on the blade, allow the lawn tractor and blade to adjust to outdoor temperature before operating.
- For improved snow removal performance, coat the blade with automotive type paste wax.



CAUTION: Inspect carefully the area to be worked before operating the snow blade. Avoid pipes, roots, curbs or other heavy obstructions.



CAUTION: Know the terrain. Avoid exceptionally steep slopes or drop offs which may be hidden by the snow. Never run the snow blade into heavy material at high speed.



CAUTION: Always lower the blade to the ground before leaving the tractor.

MAINTENANCE

CUSTOMER RESPONSIBILITIES

- Read and follow the maintenance schedule and the procedures listed in the maintenance section.

MAINTENANCE SCHEDULE Fill in dates as you complete regular service.	Service Dates											
	Before each use	After each use	Every season	Before storage								
Check for loose fasteners	X											
Check for worn or damaged parts	X											
Clean Blade		X		X								
Lubricate Blade			X									

- During the operating season, check all bolts, nuts and hairpin cotters to be sure they are secure.

Lubrication Points

- Lubricate all pivot points to help maintain proper operation of blade. Use grease packet furnished with the snow blade for lubrication of the upper portion of the lift handle rod. See figure 27.

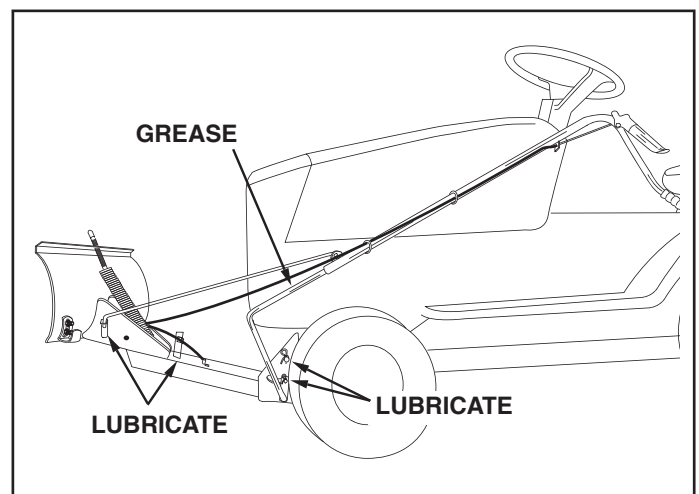

FIGURE 27

SERVICE AND ADJUSTMENTS

To Adjust Blade Spring

- The tension of the blade adjust spring may be altered to permit the blade to tilt forward to bypass solid obstructions. To change the spring tension, adjust the nuts at upper end of the spring bolt. Turn the nuts counterclockwise to relieve tension and clockwise to increase tension. Refer to figure 19 on page 12.

To Adjust Blade Shoes

- The blade shoes at the ends of blade may be raised for close work on smooth surfaces or lowered to raise the blade to work on rough or uneven areas. Make sure both shoes are set evenly and that the nuts are tightened securely. See figure 28.

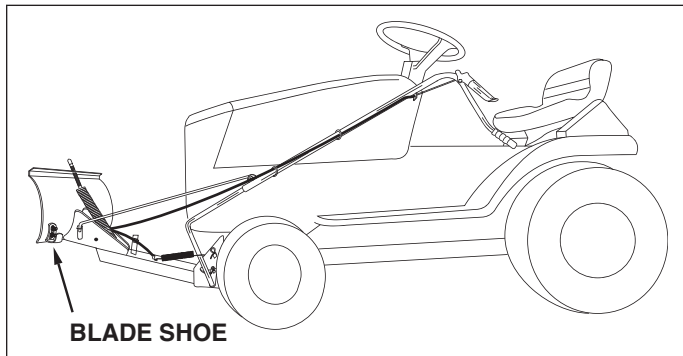

FIGURE 28

To Adjust the Blade Pivot Lock Mechanism

- If the blade will not unlock and pivot, the angle lock bars are not disengaging from the slots in the pivot plate. To correct, adjust the 5/16" hex jam nuts to draw the end of the control cable back towards the cable mount bracket. The less the threaded end of the cable extends through the bracket, the more the angle lock bars can retract to disengage from the slots in the pivot plate. See figure 29.

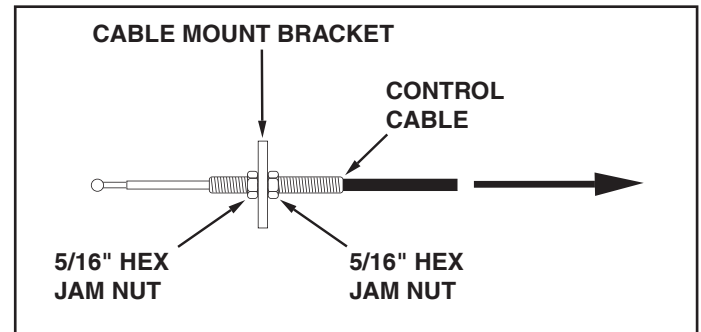

FIGURE 29

STORAGE

Recommendations When Storing

- When the snow blade is not being used, remove all dirt and rust and touch up with paint.
- Touch up bare metal with paint or apply a light coat of grease or rust preventive.
- Lubricate all pivot points and all points shown in figure 27, page 15 in the maintenance section.
- Store in a dry area, protected from weather.

To Remove Blade From Tractor

- Lower the blade head to the ground with the blade in the center (straight ahead) position.
- Remove the two clevis pins which fasten the blade's hanger brackets to the tractor's mower deck suspension brackets (or frame brackets). See figure 11 on page 10.
- Remove the clevis pin that fastens the blade's rear mounting bracket to the tractor's drawbar and drop the rear of the blade frame to the ground. See figure 10 on page 10.
- Remove the frame brackets (if used). See figure 3 on page 6.
- Back the tractor off of the blade assembly.

TROUBLESHOOTING

PROBLEM	CAUSE	CORRECTION
Blade is difficult to raise.	Lift mechanism is binding	Lubricate pivot points as shown in figure 27 on page 15.
Blade is difficult to pivot.	Handle tube is binding on lift rod.	Lubricate lift handle rod as instructed in figure 27 on page 15.
Blade will not unlock to pivot.	Lock mechanism is out of adjustment and is not disengaging.	Refer to the Service and Adjustments section on this page.

NOTES

PARTS

REPAIR PARTS LIST FOR MODEL 486.244283 - 48" SNOW BLADE

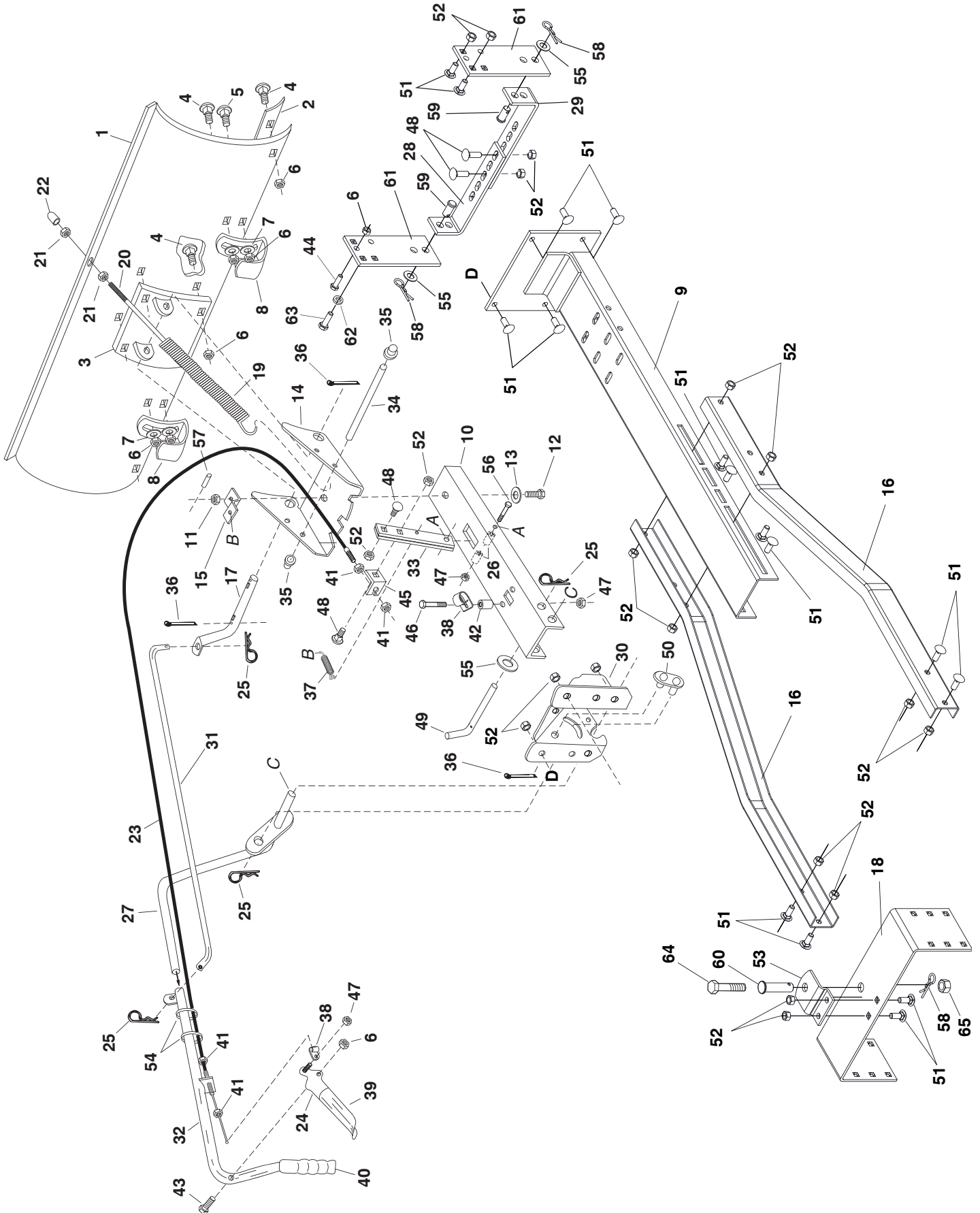

REPAIR PARTS LIST FOR MODEL 486.244283 - 48" SNOW BLADE

REF. NO.	PART NO.	QTY.	DESCRIPTION	REF. NO.	PART NO.	QTY.	DESCRIPTION
1	23955	1	Blade 48"	34	23856	1	Spring Mount Rod
2	23956	1	Wear Plate 48"	35	44917	2	Nut, 3/8"
3	62980	1	Reinforcement Plate Assembly	36	43010	3	Cotter Pin 1/8" x 1-1/4"
4	43080	6	Bolt, Carriage 5/16-18 x 3/4"	37	43348	1	Angle Lock Spring
5	44326	4	Bolt, Carriage 5/16-18 x 1"	38	746-0260	2	Cable End Fitting
6	47810	15	Nylon Lock Nut, 5/16-18 Thread	39	731-0869	1	Grip, Plastic
7	43081	4	Washer, 5/16"	40	46471	1	Handle, Grip
8	24690	2	Skid Shoe	41	712-0256	4	Hex Jam Nut, 5/16-24 Thread
9	64732	1	Thrust Channel	42	23658	1	Spacer
10	24347	1	Push Channel	43	43085	1	Hex Bolt, 5/16-18 x 1-1/2"
11	43262	1	Hex Lock Nut, 1/2-13 Thread	44	43063	4	Bolt, Hex 5/16-18 x 1" Lg.
12	23131	1	Bolt, Special Pivot	45	05762	1	Cable Mount Bracket
13	1540-118	1	Washer, Flat 1/2"	46	1509-90	1	Hex Bolt 1/4-20 x 1-1/4"
14	23958	1	Plate, Pivot 7 Ga.	47	47189	3	Nylon Lock Nut, 1/4-20 Thread
15	23130	1	Bracket, Spring Mt.	48	710-0305	4	Carriage Bolt, 3/8-16 x 1-1/4"
16	24659	2	Rear Support Channel	49	46065	1	Channel Pivot Pin
17	46066	1	Shaft, Blade Pivot	50	63034	1	Lift Link Assembly
18	25125	1	Rear Mounting Bracket	51	43350	18	Carriage Bolt, 3/8-16 x 1"
19	R9466R	1	Spring, Blade Adjust	52	HA21362	22	Nylon Lock Nut, 3/8-16 Thread
20	44071	1	Hex Bolt, 3/8-16 x 3-1/2"	53	HA23380	1	Rear Locating Bracket
21	43015	2	Hex Nut, 3/8-16 Thread	54	726-0178	2	Plastic Tie
22	44074	1	Plastic Cap	55	R19171616	3	Washer
23	746-0366	1	Control Cable Assembly	56	46071	1	Hex Bolt, 1/4-20 x 3-1/4" Lg. Gr
24	62561	1	Release Grip Assembly	57	43349	1	1/4" x 1" Spring Pin
25	43055	4	Pin, Hairpin Small 3/32"	58	43343	3	Pin, 3/32" Hairpin (Large)
26	46053	2	Spacer, .28 ID x 1"	59	44062	2	Clevis Pin, 1/2" x 1" Lg.
27	63033	1	Lift Handle Rod Assembly	60	HA3980	1	Clevis Pin, 5/8" x 1-3/4" Lg.
28	25121	1	Short Hanger Bracket	61	25124	2	Frame Bracket
29	25122	1	Long Hanger Bracket	62	43003	2	Lock Washer, 3/8"
30	24023	1	Pivot Support Bracket	63	43001	2	Hex Bolt, 3/8-16 x 1"
31	46049	1	Rod, Blade Pivot	64	R74780828	1	Hex Bolt, 1/2-13 x 1-3/4"
32	62972	1	Lift Handle Tube Assembly	65	712-3083	1	Nylon Lock Nut, 1/2-13 Thread
33	23151	2	Angle Lock Bar		49828	1	Owners Manual

Get it fixed, at your home or ours!

Your Home

For repair – **in your home** – of **all** major brand appliances, lawn and garden equipment, or heating and cooling systems, **no matter who made it, no matter who sold it!**

For the replacement parts, accessories and owner's manuals that you need to do-it-yourself.

For Sears professional installation of home appliances and items like garage door openers and water heaters.

1-800-4-MY-HOME® (1-800-469-4663)

Call anytime, day or night (U.S.A. and Canada)

www.sears.com www.sears.ca

Our Home

For repair of carry-in items like vacuums, lawn equipment, and electronics, call or go on-line for the location of your nearest

Sears Parts & Repair Center.

1-800-488-1222

Call anytime, day or night (U.S.A. only)

www.sears.com

To purchase a protection agreement (U.S.A.) or maintenance agreement (Canada) on a product serviced by Sears:

1-800-827-6655 (U.S.A.)

1-800-361-6665 (Canada)

Para pedir servicio de reparación a domicilio, y para ordenar piezas:

1-888-SU-HOGAR®

(1-888-784-6427)

Au Canada pour service en français:

1-800-LE-FOYER^{MC}

(1-800-533-6937)

www.sears.ca

The Sears logo is displayed in a large, stylized font. The word "Sears" is written in a bold, serif typeface. A thick, curved underline is positioned beneath the letters "e" and "a".

Free Manuals Download Website

<http://myh66.com>

<http://usermanuals.us>

<http://www.somanuals.com>

<http://www.4manuals.cc>

<http://www.manual-lib.com>

<http://www.404manual.com>

<http://www.luxmanual.com>

<http://aubethermostatmanual.com>

Golf course search by state

<http://golfingnear.com>

Email search by domain

<http://emailbydomain.com>

Auto manuals search

<http://auto.somanuals.com>

TV manuals search

<http://tv.somanuals.com>