

User's Guide

for the

CRATE AUDIO

SPA100

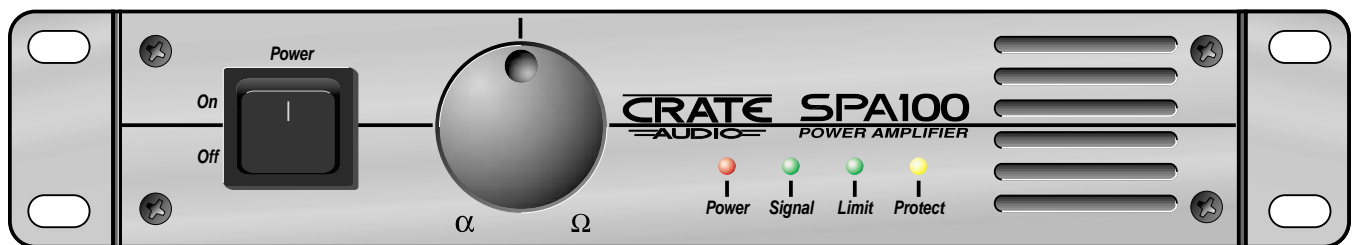

1/2-Rack Power Amplifier

In order to achieve maximum performance from your new Crate Audio SPA Series Power Amp we recommend that you read this user's guide prior to its use.



Table of Contents:

Introduction	.3
Features	.3
Front Panel Information	.4
Rear Panel Information	.5
Speaker Impedances And Power Ratings	.6
Joining Two Amplifiers For Rack Mounting	.6
Installations and Operation	
Mono Operation (One Amplifier)	.7
Stereo Operation (Two Amplifiers)	.8
Main / Monitor Combination (Two Amplifiers)	.9
Biamping (Two Amplifiers)	.10
Triamping (Three Amplifiers)	.11
System Block Diagram	.back cover
Technical Specifications	.back cover

1. Read these instructions.
2. Keep these instructions.
3. Heed all warnings.
4. Follow all instructions.
5. Do not use this apparatus near water.
6. Clean only with a damp cloth.
7. Do not block any of the ventilation openings. Install in accordance with the manufacturer's instructions.
8. Do not install near any heat sources such as radiators, heat registers, stoves, or other apparatus (including amplifiers) that produce heat.
9. Do not defeat the safety purpose of the polarized-type plug. A polarized plug has two blades with one wider than the other. The wide blade is provided for your safety. When the provided plug does not fit into your outlet, consult an electrician for replacement of the obsolete outlet.
10. Protect the power cord from being walked on or pinched particularly at plug, convenience receptacles, and the point where they exit from the apparatus.
11. Only use attachments/accessories specified by the manufacturer.
12. Use only with a cart, stand, tripod, bracket, or table specified by the manufacturer, or sold with the apparatus. When a cart is used, use caution when moving the cart/apparatus combination to avoid injury from tip-over.
13. Unplug this apparatus during lightning storms or when unused for long periods of time.
14. Refer all servicing to qualified service personnel. Servicing is required when the apparatus has been damaged in any way, such as power-supply cord or plug is damaged, liquid has been spilled or objects have fallen into the apparatus, the apparatus has been exposed to rain or moisture, does not operate normally, or has been dropped.





SPA100 1/2-Rack Power Amplifier

Introduction:

Congratulations. You have selected one of the finest sound reinforcement amplifiers available, the Crate Audio SPA100 1/2-Rack Power Amplifier. Our many years of experience in high-performance audio equipment, combined with our extensive research and development procedures, have enabled us to produce an amplifier which provides the highest quality and reliability possible.

Like all Crate products, your SPA100 amplifier was designed and manufactured using only the finest components and materials. Each amplifier design must satisfy our team of highly-trained technicians and musicians before it is approved. We insist upon high level of quality control to ensure that each amplifier produced will provide its owner with years of trouble-free, ear-pleasing performance.

Your new SPA100 is a flexible part of any sound system – simple to connect and easy to operate – if you first know how to incorporate it into your application. Several configurations are covered in this manual, along with important information regarding impedance ratings and output power. In order to get the best performance and highest level of quality and reliability from your new amplifier, please read this user's guide before operating the unit.

Features:

The Crate SPA100 is a ruggedly constructed high quality power amplifier designed to give you continuous performance with professional results. Two of these amplifiers can be mounted side by side in a standard 19" rack, requiring only 1-3/4 inches of vertical rack space. The automatic variable-speed internal cooling system uses the front, side and rear of the amplifier - not the top and bottom - for its air intake and exhaust, allowing you to stack multiple components closer together in a rack mount situation.

The SPA100 produces up to 100 watts of power @ 4 ohms, or 75 watts @ 8 ohms. Several "professional" features have been built into the SPA100, such as 1/4" phone and XLR input jacks with electronically balanced Low or High impedance operation. Built-in limiting circuitry constantly monitors the output of the amplifier for clipping, thus helping prevent the generation of speaker-damaging square waves. A built-in protection circuit guards the amplifier against damages from overloads, short circuits, or overheating. In addition, each channel features a Signal LED to assist in hookup and troubleshooting, and a Peak LED to allow you to set the input level for the best signal to noise ratio.

<div style="display: inline-block; text-align: center;"> <p>CAUTION RISK OF ELECTRIC SHOCK DO NOT OPEN</p> </div>	<div style="display: inline-block; text-align: center;"> <p>PRECAUCION RIESGO DE CORRIENTAZO NO ABRA</p> </div>	<div style="display: inline-block; text-align: center;"> <p>ATTENTION RISQUE D'ELECTROCUTION NE PAS OUVRI</p> </div>
<p>WARNING: TO REDUCE THE RISK OF FIRE OR ELECTRIC SHOCK, DO NOT EXPOSE THIS APPARATUS TO RAIN OR MOISTURE. TO REDUCE THE RISK OF ELECTRIC SHOCK, DO NOT REMOVE COVER. NO USER-SERVICEABLE PARTS INSIDE. REFER SERVICING TO QUALIFIED SERVICE PERSONNEL.</p>	<p>PRECAUCION: PARA REDUCIR EL RIESGO DE INCENDIOS O DESCARGAS ELECTRICAS, NO PERMITA QUE ESTE APARATO QUEDA EXPUESTO A LA LLUVIA O LA HUMEDAD. PARA DISMINUIR EL RIESGO DE CORRIENTAZO, NO ABRA LA CUBIERTA. NO HAY PIEZAS ADENTRO QUE EL USUARIO PUEDA REPARAR DEJE TODO MANTENIMIENTO A LOS TECNICOS CALIFICADOS.</p>	<p>ATTENTION: PROTEGEZ CET APPAREL DE LA PLUIE ET DE L'HUMIDITE AFIN D'EVITER TOUT RISQUE D'INCENDIE OU D'ELECTROCUTION. POUR REDUIRE D'ELECTROCUTION NE PAS ENLEVER LE COUVERCLE. AUCUNE PIECE INTERNE N'EST REPARABLE PAR L'UTILISATEUR. POUR TOUTE REPARATION, S'ADRESSER A UN TECHNICIEN QUALIFIE.</p>
IMPORTANT SAFETY INSTRUCTIONS		
<ul style="list-style-type: none"> • READ, FOLLOW, HEED, AND KEEP ALL INSTRUCTIONS AND WARNINGS. • DO NOT OPERATE NEAR ANY HEAT SOURCE AND DO NOT BLOCK ANY VENTILATION OPENINGS ON THIS APPARATUS. FOR PROPER OPERATION, THIS UNIT REQUIRES 3" (75CM) OF WELL VENTILATED SPACE AROUND HEATSINKS AND OTHER AIR FLOW PROVISIONS IN THE CABINET. • DO NOT USE THIS APPARATUS NEAR SPLASHING, FALLING, SPRAYING, OR STANDING LIQUIDS. • CLEAN ONLY WITH LINT-FREE DAMP CLOTH AND DO NOT USE CLEANING AGENTS. • ONLY CONNECT POWER CORD TO A POLARIZED, SAFETY GROUNDED OUTLET WIRED TO CURRENT ELECTRICAL CODES AND COMPATIBLE WITH VOLTAGE, POWER, AND FREQUENCY REQUIREMENTS STATED ON THE REAR PANEL OF THE APPARATUS. • PROTECT THE POWER CORD FROM DAMAGE DUE TO BEING WALKED ON, PINCHED, OR STRAINED. • UNPLUG THE APPARATUS DURING LIGHTNING STORMS OR WHEN UNUSED FOR LONG PERIODS OF TIME. • ONLY USE ATTACHMENTS, ACCESSORIES, STANDS, OR BRACKETS SPECIFIED BY THE MANUFACTURER FOR SAFE OPERATION AND TO AVOID INJURY. • WARNING: TO REDUCE THE RISK OF ELECTRIC SHOCK OR FIRE, DO NOT EXPOSE THIS UNIT TO RAIN OR MOISTURE. • SERVICE MUST BE PERFORMED BY QUALIFIED PERSONNEL. • OUR AMPLIFIERS ARE CAPABLE OF PRODUCING HIGH SOUND PRESSURE LEVELS. CONTINUED EXPOSURE TO HIGH SOUND PRESSURE LEVELS CAN CAUSE PERMANENT HEARING IMPAIRMENT OR LOSS. USER CAUTION IS ADVISED AND EAR PROTECTION IS RECOMMENDED IF UNIT IS OPERATED AT HIGH VOLUME. 		
<p>EXPLANATION OF GRAPHICAL SYMBOLS: EXPLICACION DE SIMBOLOS GRAFICOS: EXPLICATION DES SYMBOLES GRAPHIQUES:</p>	= "DANGEROUS VOLTAGE" "VOLTAJE PELIGROSO" "DANGER HAUTE TENSION"	= "IT IS NECESSARY FOR THE USER TO REFER TO THE INSTRUCTION MANUAL" "ES NECESARIO QUE EL USUARIO SE REFIERA AL MANUAL DE INSTRUCCIONES." "REFERREZ-VOUS AU MANUAL D'UTILISATION"



Front Panel Information:

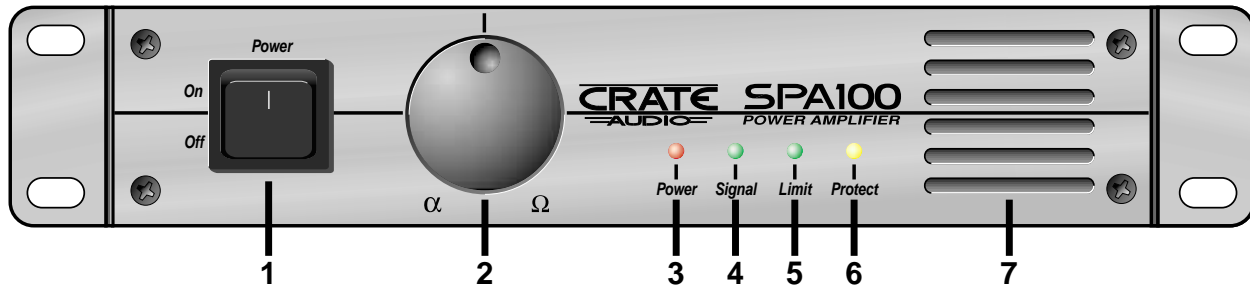

1: POWER SWITCH: This switch applies AC power to the amplifier. The amp is on when the top of the switch is depressed, off when the bottom of the switch is depressed. The Power LED indicator (#3) illuminates when the amplifier is on.

2: LEVEL CONTROL: This rotary potentiometer controls the level or gain of the amplifier, with the fully-clockwise position providing a sensitivity of +2dBv. Normal calibration of the SPA100 to a mixer would cause the Peak LED to flash at the same time that the mixer's VU meters indicate full output.

3: POWER LED: This LED illuminates when AC power is applied by means of the Power switch (#1). If the LED fails to illuminate, check the AC outlet or the fuse on the rear panel (#13).

4: SIGNAL LED: This LED illuminates when a signal is detected at the amplifier's output terminals. The level of the signal must be at least 1% of the amplifier's full rated output to cause the LED illuminate.

5: LIMIT LED: The SPA100 employs an internal limit circuit to alert the user if the amplifier is approaching clipping. The Limit LED illuminates whenever the input signal attempts to overdrive the amplifier. (Not only does clipping produce harsh sounding distortion, it is also capable of damaging speaker components – particularly high fre-

quency drivers.) Periodic flashing of the Limit LED indicates operation at or near full output. This is normal. Steady illumination of the LED indicates constant operation of the Limiter, with the possibility that the input signal should be reduced by means of the Level control (#2).

6: PROTECT LED: This LED illuminates whenever the internal protection circuit is activated. The protection relay is activated for a short period upon initial turn-on and at turn-off to prevent transient "spikes" from being reproduced through your speakers. A fault condition is also indicated in the event of an overtemperature status, or if DC voltages are present at the output. During thermal protection, the output is shut down until the temperature returns to a safe operating level. In the event of DC voltage on the output, the output will be internally disconnected. The circuitry associated with the LED indicator provides valuable protection for both the amplifier and your speakers.

7: FRONT PANEL EXHAUST VENT: The SPA100 employs a variable-speed internal cooling fan to draw air through the unit to keep it running cool even under extreme operating conditions. Air is drawn in through the unit's rear and side intake vents and is forced out through the front panel exhaust vent. Keep these vents clear and free from obstruction at all times to insure proper cooling.

Rear Panel Information:

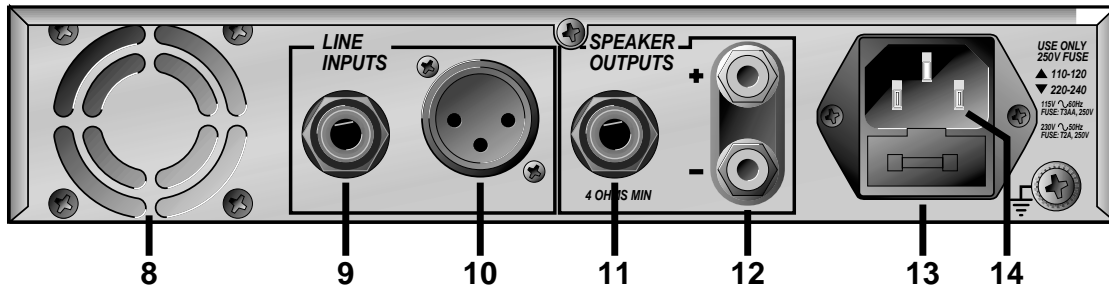

8: FAN INTAKE AREA: Air for cooling the SPA100 is drawn in by the fan at the rear and side, directed through the amplifier, and exhausted through the front panel vent. Do not block or impede the airflow through these vents and keep the area free of foreign materials.

9: LINE INPUT: This 1/4" jack accepts line level signal sources by means of a cable fitted with a standard 1/4" phone plug. Low impedance balanced or unbalanced, as well as high impedance sources are acceptable for this input. Low impedance balanced inputs are to be wired as follows: Tip = Signal +, Ring = Signal -, Sleeve = Ground.

10: MIC INPUT: This XLR jack accepts any balanced or unbalanced low impedance line level source by means of a three-pin XLR plug. The wiring for the plug is as follows: Pin 1 = Ground, Pin 2 = Signal +, Pin 3 = Signal -.

11: 1/4" SPEAKER OUTPUT: This 1/4" jack offers a convenient method of connecting the amplifier to your speakers using a cable terminated with a 1/4" plug.

12: BINDING POST SPEAKER OUTPUT: These five-way binding posts offer an excellent method of connecting the amplifier to your speakers using cables terminated with spade lugs, banana plugs, or bare wire. Use of these connectors is highly recommended for high power operation.

13: FUSE HOLDER: The SPA100 employs an AC line fuse to help protect it from damages due to excessive current demands. If the amplifier does not function, check this fuse. If it is blown, replace it *ONLY* with the same size and type as indicated near the holder. If the fuse blows repeatedly, have the amplifier checked by a qualified service person.

14: AC LINE IN: Firmly insert the supplied AC power cord into this socket until it is fully seated. This grounded power cord is to be plugged into a grounded power outlet, wired to current electric codes and compatible with voltage, power, and frequency requirements stated on the rear panel. **Do not attempt to defeat the safety ground connection.**

Speaker Impedances And Power Ratings:

When connecting speaker cabinets, you must observe proper load impedances. Whenever connecting multiple cabinets to an amplifier, the total load impedance must be calculated to insure proper performance from the amplifier. The impedance chart which follows shows the total load impedances of many common parallel speaker combinations:

IMPEDANCE CHART:

		SYSTEM ONE					
		SINGLE SPEAKER		TWO SPEAKERS IN PARALLEL			
		8Ω	16Ω	8:16Ω	16:16Ω		
SYSTEM TWO	ONE SPKR	8Ω	4Ω	5.3Ω	3.2Ω	4Ω	
	16Ω	16Ω	5.3Ω	8Ω	4Ω	5.3Ω	
TWO IN PARALLEL	8:16Ω	8:16Ω	3.2Ω	4Ω	2.7Ω	3.2Ω	
	16:16Ω	16:16Ω	4Ω	5.3Ω	3.2Ω	4Ω	

Note that some combinations result in impedances less than 4 ohms. (the shaded areas) These combinations are **not recommended** for the SPA100 and should be avoided. They are included on the chart for reference only. Too low an impedance will activate the amplifier's protection circuit.

The formula for this chart is:

$$\frac{1}{1/R_1 + 1/R_2 + \dots + 1/R_N}$$

Where "R" is the speaker impedance. So, using two 16 ohm speakers in combination with one 8 ohm speaker, the impedance would be:

$$\frac{1}{1/8 + 1/16 + 1/16} = \frac{1}{.125 + .0625 + .0625} = \frac{1}{.250} = 4 \text{ ohm load impedance}$$

You can also determine the combined impedance by means of the Impedance Chart. The combined impedance appears at the intersection of the 16:16 column (System One) and 8Ω row (System Two).

Power Output:

The power output of an amplifier changes in accordance with the load impedance or mode of operation. The total output power of the SPA100 is as follows:

total load impedance:	8 ohms	4 ohms
total output power:	75 watts	100 watts

Output Power Per Speaker Cabinet:

If each parallel connected speaker cabinet has the same rated impedance, divide the total power output by the number of cabinets used. For example: Four 16 ohm cabinets have a total load impedance of 4 ohms (see the impedance chart above), which allows a total output power of 100 watts RMS: $100/4 = 25$ watts RMS for each cabinet.

Speaker cabinets with different rated impedances will draw different amounts of power. To calculate the power output per cabinet, obtain the total load impedances from the impedance chart above and divide it by each speaker impedance. For example: Three speaker cabinets, one with a rated impedance of 8 ohms and two at 16 ohms are connected in parallel. According to the impedance chart, the total load impedance is 4 ohms, which means a total power output of 100 watts as above. Divide the total impedance by the impedance of each speaker and multiply the results by 100.

$$\frac{R_{\text{total}}}{R_N} = \frac{4/8 = 1/2 \times 100 = 50 \text{ watts for the 8 ohm cabinet}}{4/16 = 1/4 \times 100 = 25 \text{ watts for each of the 16 ohm cabinets}}$$

Joining Two Amplifiers For Rack Mounting:

The SPA100 amplifier is shipped with a heavy duty steel joining plate (not attached to the unit). This allows two amplifiers to be mounted side by side in a single rack space (19"W x 1-3/4"H).

(1) Remove one rack mount flange from each amplifier: the flange on the *right* side of the amplifier on the left and the flange on the *left* side of the amplifier on the right.

(2) Remove two front panel screws from each amplifier: the two screws on the *right* side of the amplifier on the left and the two screws on the *left* side of the amplifier on the right.

(3) Position the amplifiers side by side, align the holes in the joining plate with the holes in the front panel of the adjacent amplifier. Insert the screws through the joining plate into the front panel of the adjacent amplifier and tighten securely.

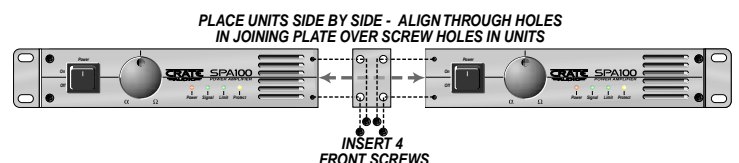
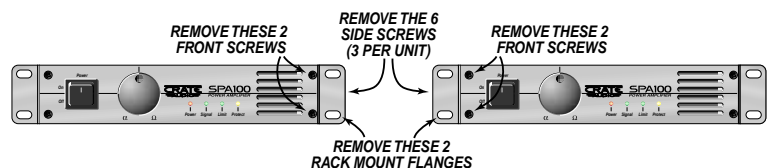



SPA100 1/2-Rack Power Amplifier

Installations and Operation:

Mono Operation (One Amplifier):

Connect a SPA100 between the outputs of your mono signal source and your speaker(s). The minimum impedance for the speaker(s) is 4 ohms.

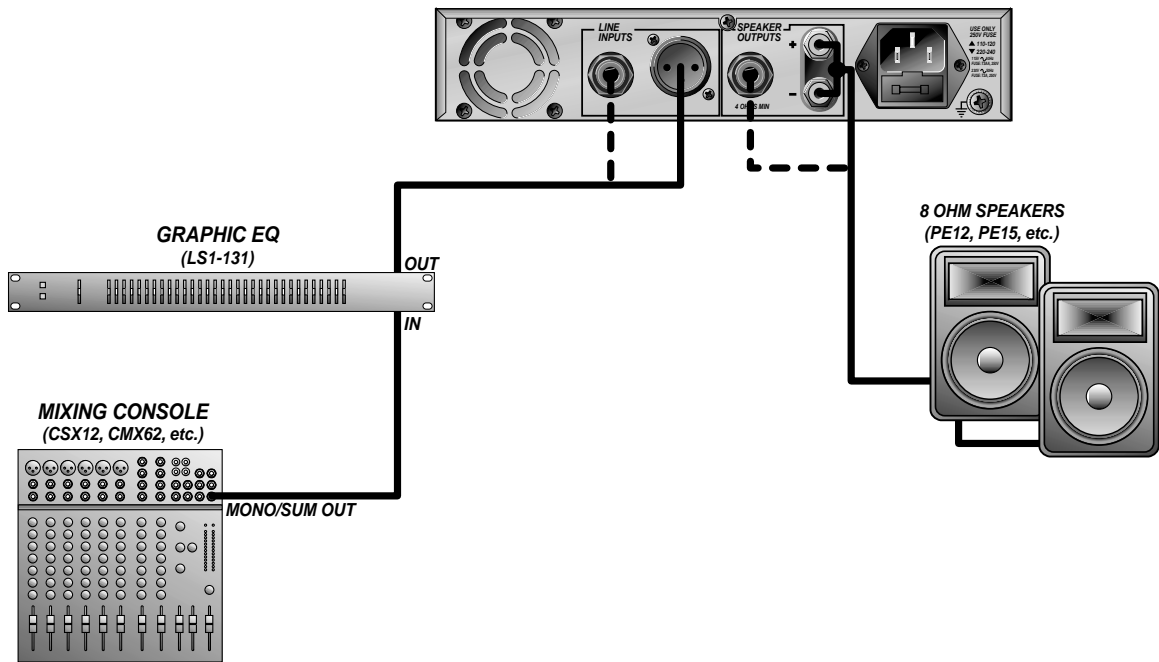

Installations and Operation:

Stereo Operation (Two Amplifiers):

Connect one SPA100 between the left channel output of your stereo signal source and your left channel speaker(s). Connect another SPA100 between the right channel output of your stereo signal source and your right channel speaker(s). The minimum impedance for the speaker(s) is 4 ohms for each amplifier.

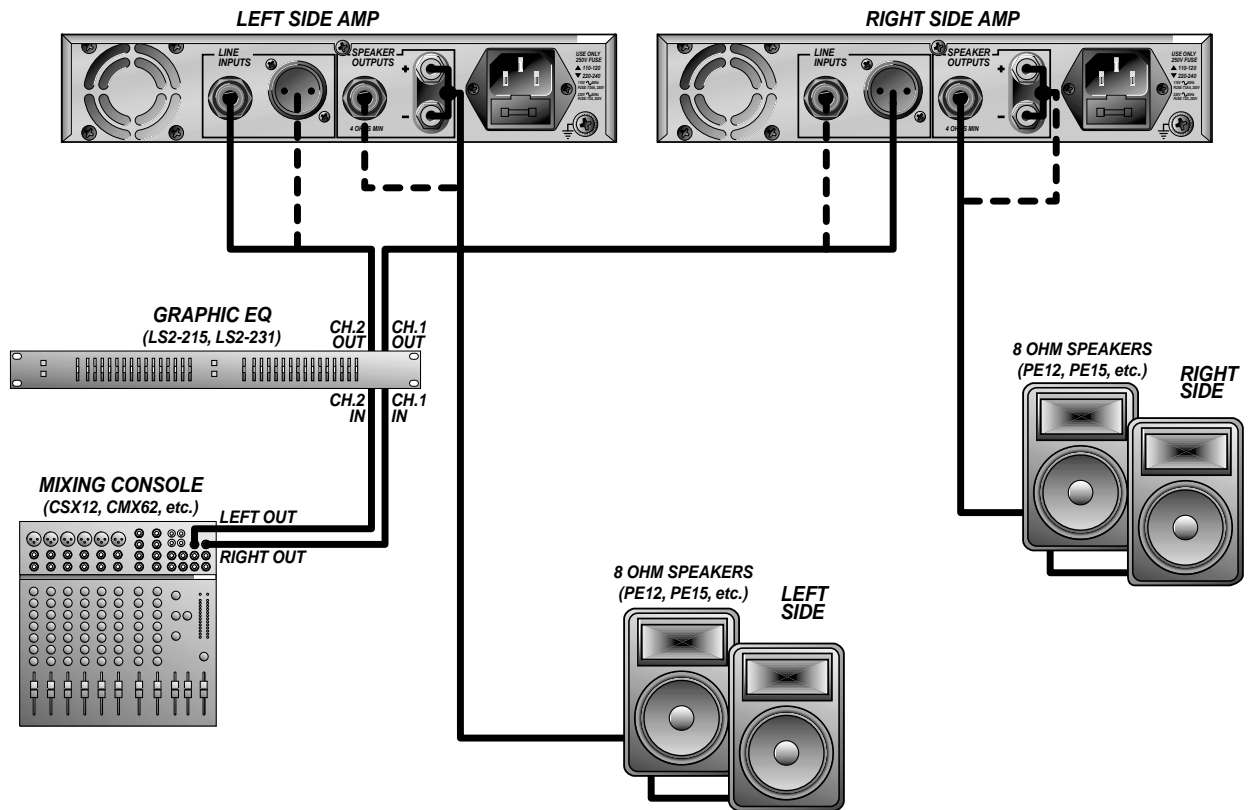

Installations and Operation:

Stereo Operation (Two Amplifiers):

Connect one SPA100 between the output of your house speaker signal source and your house speaker(s). Connect another SPA100 between the output of your monitor signal source and your monitor speaker(s). The minimum impedance for the speaker(s) is 4 ohms for each amplifier.

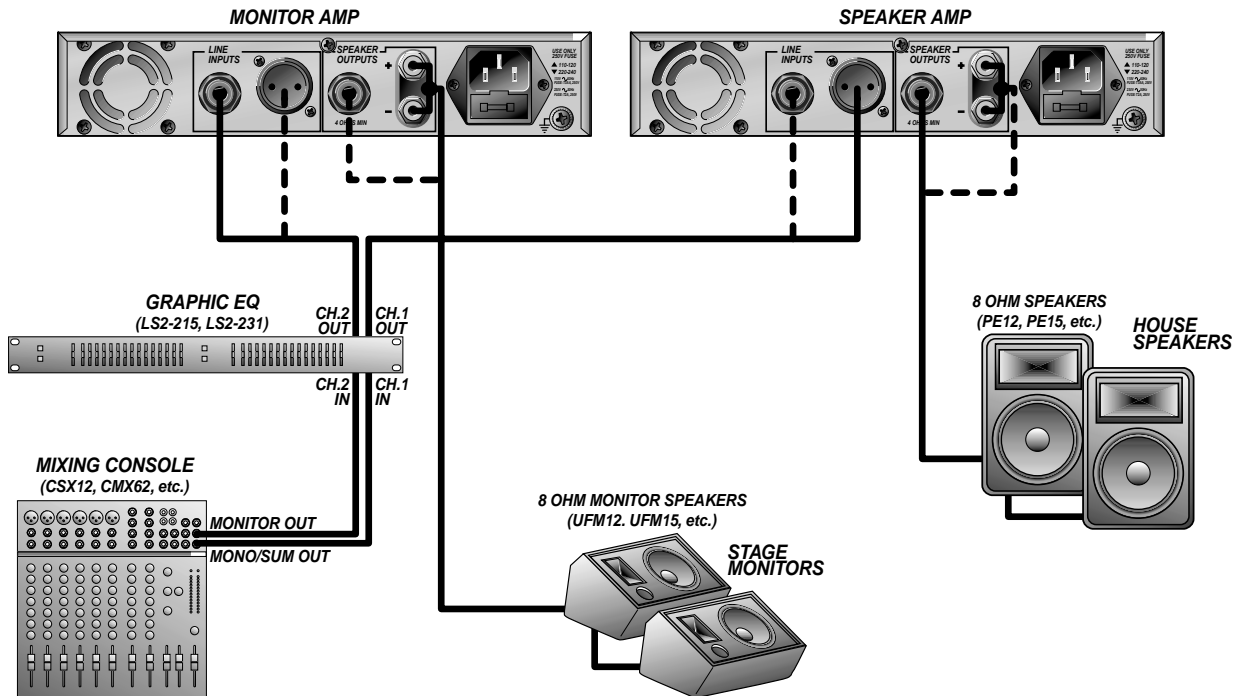

Installations and Operation:

Biamping (Two Amplifiers):

Connect one SPA100 between the output of your low frequency signal source and your low frequency speaker(s). Connect another SPA100 between the output of your full range signal source and your full range speaker(s). The minimum impedance for the speaker(s) is 4 ohms for each amplifier.

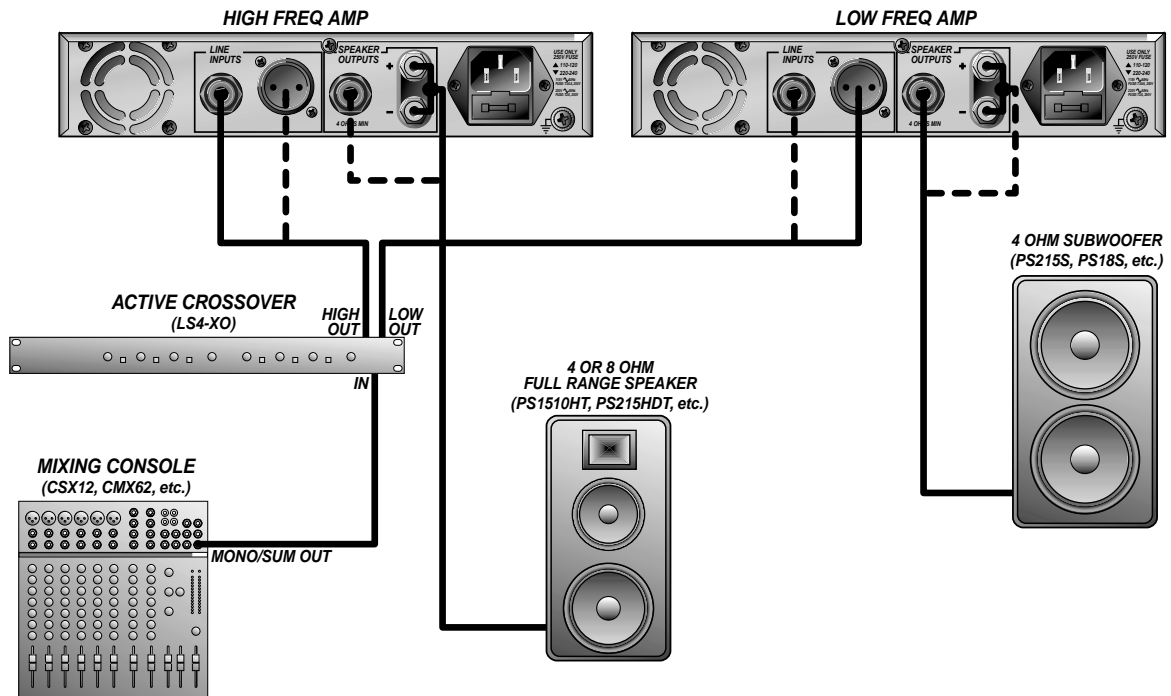



SPA100 1/2-Rack Power Amplifier

Installations and Operation:

Triamping (Three Amplifiers):

Connect one SPA100 between the output of your low frequency signal source and your low frequency speaker(s). Connect another SPA100 between the output of your mid frequency signal source and your mid frequency speaker(s). Connect a third SPA100 between the output of your high frequency signal source and your high frequency speaker(s). The minimum impedance for the speaker(s) is 4 ohms for each amplifier.

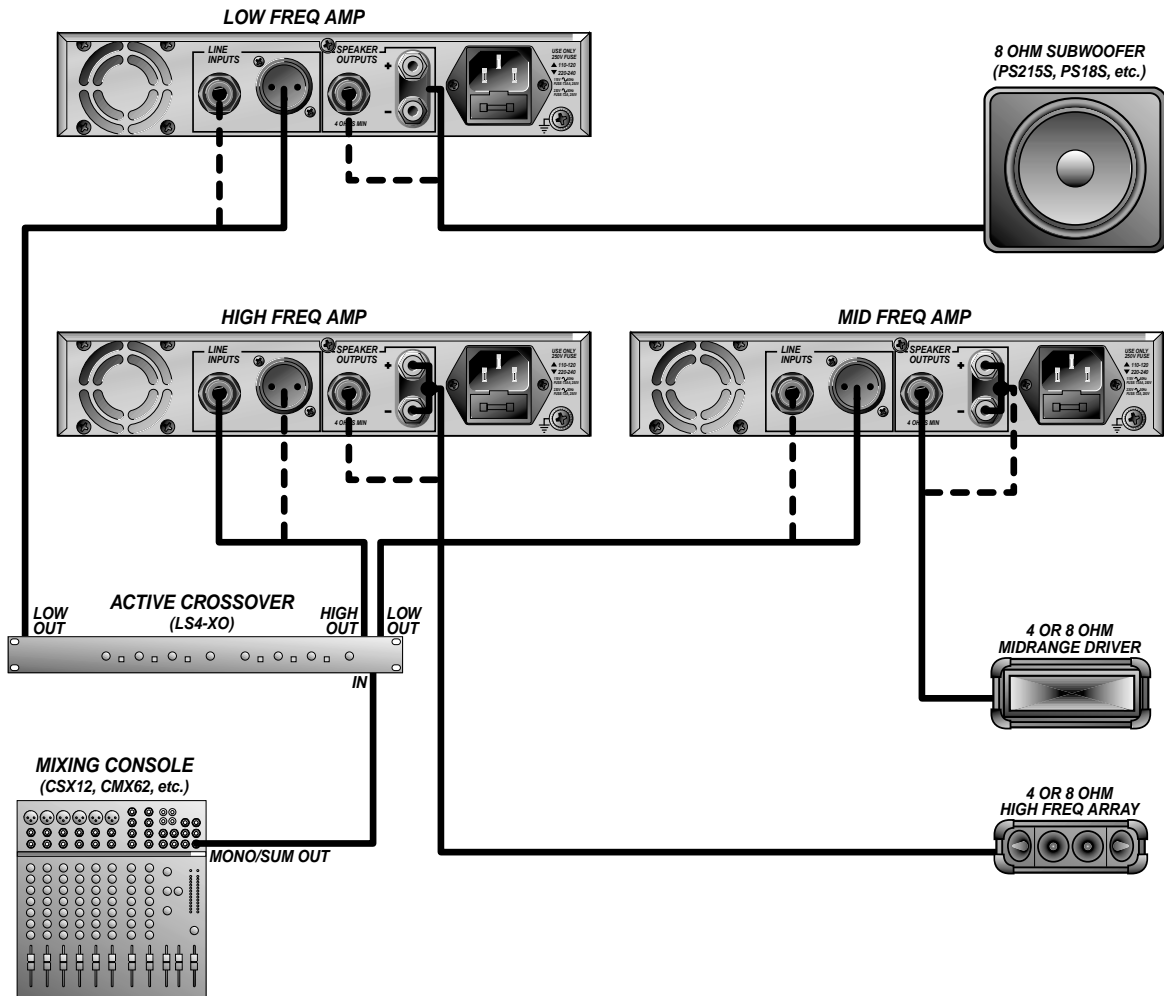



SPA100 1/2-Rack Power Amplifier

Technical Specifications

POWER OUTPUT	100 Watts RMS @ 4 ohms 75 Watts RMS @ 8 ohms
FREQUENCY RESPONSE	+/-0.5dB, 20Hz – 20kHz @ full rated power
TOTAL HARMONIC DISTORTION	Less than .06%, 20Hz – 20kHz Typical .02% @ 1kHz
INTERMODULATION DISTORTION	Less than .05% @ 300W / 4 ohms
SLEW RATE	20 volts per nanosecond
SIGNAL TO NOISE RATIO	Greater than 100dB
INPUT TYPE AND IMPEDANCE	Transformerless electronically balanced, 20k actual load impedance. Suitable for Low or High-Z balanced line. 3 pin "XLR" plus 3 conductor 1/4" phone jack input per channel.
INPUT SENSITIVITY	1.0 V RMS
LOAD IMPEDANCE	4 ohms or greater
OUTPUT CONNECTIONS	1/4" jack & 5-way binding posts
PROTECTION CIRCUITRY	Short circuit, RF burnout, overtemp, speaker protection relays, turn on/off transient protection, DC protection and limiter (Anti-clip)
COOLING	Forced air fan cooling, rear intake, front and side exhaust
POWER REQUIREMENTS	DOMESTIC: 120 VAC 60Hz, 75VA EXPORT: 100-115 VAC 50/60Hz, 75VA 220-240 VAC 50/60Hz, 75VA
SIZE AND WEIGHT	10.5" W x 1.75" H x 11.5" D; 9.3 lbs.

System Block Diagram:

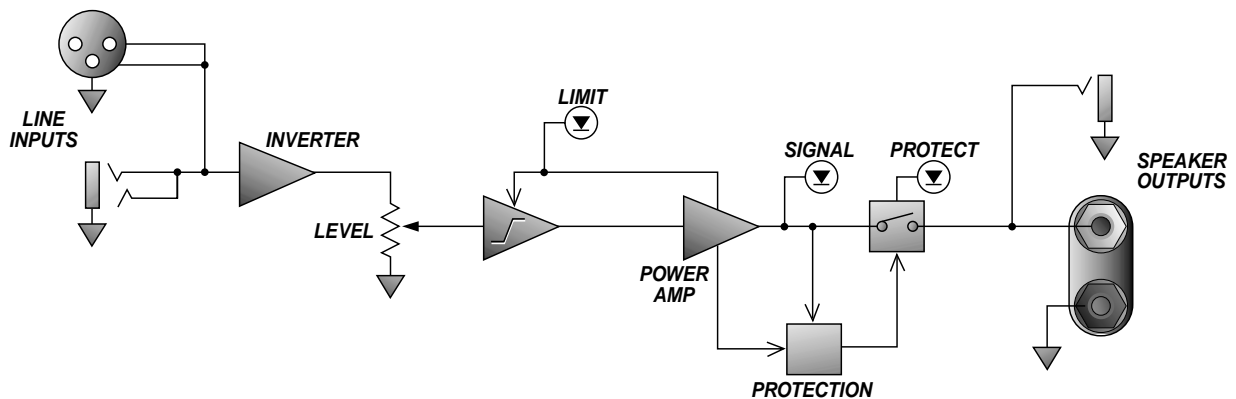

Due to ongoing product development and improvement, the specifications contained herein are subject to change without notice.



www.crateaudio.com

©2003 SLM Electronics, Inc. • A Division of St. Louis Music, Inc.
1400 Ferguson Avenue • St. Louis, MO 63133

18-567-01 • 05/16/03

Download from Www.Somanuals.com. All Manuals Search And Download.



Free Manuals Download Website

<http://myh66.com>

<http://usermanuals.us>

<http://www.somanuals.com>

<http://www.4manuals.cc>

<http://www.manual-lib.com>

<http://www.404manual.com>

<http://www.luxmanual.com>

<http://aubethermostatmanual.com>

Golf course search by state

<http://golfingnear.com>

Email search by domain

<http://emailbydomain.com>

Auto manuals search

<http://auto.somanuals.com>

TV manuals search

<http://tv.somanuals.com>