

The logo for Creda, featuring the word "Creda" in a bold, white, sans-serif font centered within a solid black rectangular background.

## **Instructions for Installation and Use**

Refrigerator

Model CUL16G

### **To the Installer**

**Before installation fill in the product details on the back cover of this booklet.  
The information can be found on the rating plate.**

### **To the User**

**You must read the instructions prior to installing and using the appliance  
and then retain them for future reference.**

# CONTENTS

|                                      |            |
|--------------------------------------|------------|
| Product Safety                       | 3          |
| Installation                         | 3          |
| Electrical Connection                | 4          |
| Get to Know your Appliance           | 5          |
| Getting your Appliance ready for use | 6          |
| Storing Food in the Refrigerator     | 6-7        |
| Energy Saving Tips                   | 7          |
| Caring for your Appliance            | 8          |
| Troubleshooting                      | 9          |
| Notes                                | 10-11      |
| Key Contacts                         | Back Cover |

## Retention of this Instruction Book

This Instruction Book must be kept handy for reference as it contains important details on the safe and proper use of the appliance.

If you sell or pass the appliance to someone else, or move house and leave it behind, make sure this Book is also provided so the new owner can become familiar with the appliance and safety warnings.

If the Book is lost or damaged a copy may be obtained from:  
GDA LTD., Morley Way, Peterborough, PE2 9JB



# PRODUCT SAFETY

## ATTENTION

Read your manual carefully since it contains instructions which will ensure safe installation, use and maintenance of your appliance.

Your Refrigerator is built to International safety standards (EN60) and has been awarded the European approval mark (IMQ) for compliance with UK electrical safety requirements. It also meets the EC standards on the prevention and elimination of radio interference (EC directive 87/308 - 02.06.89).

1. This appliance must not be installed outdoors - not even in an area protected by a roof. It is extremely dangerous to leave it exposed to rain or storms.
2. It must only be used by adults and exclusively to refrigerate and freeze foodstuffs, following the instructions for use contained in this manual.
3. Do not ever touch or handle the appliance with bare feet or with wet hands or feet.
4. It is highly recommended that you do not use extension cords or multiple socket adapters. If the refrigerator is installed between cabinets, make sure that the cord is not bent or dangerously pinched or compressed.
5. Never pull on the cord or the refrigerator to remove the plug from the wall socket - this is very dangerous.
6. Never touch the cooling components within the appliance, especially with wet hands because this could result in injury.
7. Never put ice cubes just removed from the freezer into your mouth because they could stick to your mouth and cause burns.

8. Never clean the appliance or perform maintenance without first disconnecting it from the electrical mains. Turning the thermostat knob to the ● setting does not suffice to break all electrical contact with the mains.

9. Before having your old refrigerator picked up for disposal, remove or make inoperable any locking devices to prevent children who might play in or around the appliance from being locked inside.

10. Before calling for service/assistance in the case of malfunction, consult the chapter entitled "Troubleshooting" to determine whether it is possible to eliminate the problem. Do not try to repair the problem by trying to access the internal components of the appliance.

11. If damaged, the power supply cord on this appliance must necessarily be replaced by our service centre because special tools are required for replacement.

12. Do not use electric appliances inside the compartment for food storage, if these are not those recommended by the manufacturer.

13. At the end of the functional life of your appliance – containing cyclopentane gas in the insulation foam and perhaps gas R600a (isobutane) in the refrigeration circuit – the latter should be made safe before being sent to the dump. For this operation, please contact your dealer or the Local Organisation in charge of waste disposal.

# INSTALLATION

**To ensure that the appliance operates properly and to reduce energy consumption, it is important that the appliance is installed correctly.**

## Ventilation

The compressor and condenser generate heat and, therefore, need to be ventilated properly. Avoid placing refrigerator in direct sunlight, or next to an electric stove or similar appliance. Areas not adequately ventilated are not suitable for this appliance.

During installation, make sure not to cover or obstruct the grates that allow for proper ventilation of the appliance.

## Away from Heat

Avoid positioning the appliance in a place where it is directly exposed to sunlight or near an oven, hob or the like.

## Electrical Connection and Earthing

Before proceeding with the electrical connection, make sure that the voltage indicated on the rating plate, located at the bottom left near the fruit and vegetable crisper, corresponds

to the mains voltage in your home and that the socket is fitted with a standard earthing wire in accordance with safety standards for 46/90 systems. If the socket is not fitted with an earthing wire, the manufacturer will not be held liable for any damages and/or injuries arising out of the use of the appliance. Do not use multiple sockets or adapters.

**Position the appliance in such a way that you can access the socket where it is plugged in.**

## Insufficient power?

The electrical socket must be able to handle the maximum power load of the appliance, which is indicated on the rating plate located at the bottom left next to the vegetable crisper.

## Before making the electrical connection ...

After the appliance has been delivered, place it in the vertical upright position and wait at least 3 hours before inserting the plug into the socket in order to ensure that it functions properly.

# ELECTRICAL CONNECTION

Your appliance is supplied with a 13amp fused plug that can be plugged into a 13amp socket for immediate use. Before using the appliance please read the instructions below.

## **WARNING:**

**THIS APPLIANCE MUST BE EARTHED.**

## **Replacing fuse covers:**

When replacing a faulty fuse, a 13amp ASTA approved fuse to BS 1362 should always be used and the fuse cover re-fitted.

If the fuse cover is lost, the plug must not be used until a replacement is obtained.

## **Replacement fuse covers:**

If a replacement fuse cover is fitted, it must be of the correct colour as indicated by the coloured marking or the colour that is embossed in words on the base of the plug.

## **Changing the plug:**

### **Removing the plug**

If your appliance has a non-rewireable moulded plug and you should wish to remove it to add a longer cable or to re-route the mains cable through partitions, units etc. please ensure that either:

- The plug is replaced by a fused 13amp re-wireable plug bearing the BSI mark of approval.

or

- The mains cable is wired directly into a 13amp cable outlet, controlled by a switch (in compliance with BS 5733) which is accessible without moving the appliance.

### **Disposing of the plug**

Cut off and dispose of the supplied plug if it does not fit your socket. The cable should be cut as close as possible to the moulded plug. Remove the fuse.

## **WARNING:**

**To avoid a shock hazard do not insert the discarded plug into a socket anywhere else.**

## **Fitting a new plug**

### **IMPORTANT:**

**WIRES IN THE MAINS LEAD ARE COLOURED IN ACCORDANCE WITH THE FOLLOWING CODE...**

|                  |   |         |
|------------------|---|---------|
| Green and Yellow | - | Earth   |
| Blue             | - | Neutral |
| Brown            | - | Live    |

As the colours of the wires in the mains lead may not correspond with the coloured markings identifying the terminals in your plug, proceed as follows:

- Connect Green and Yellow wire to terminal marked 'E' or  $\frac{\perp}{\equiv}$  or coloured Green and Yellow.
- Connect Brown wire to terminal marked 'L' or coloured red or brown.
- Connect Blue wire to terminal marked 'N' or coloured Black or Blue.

If a 13amp plug (BS 1363) is used it must be fitted with a 13amp fuse. A 15amp plug must be protected by a 15amp fuse, either in the plug or adaptor or at the distribution board.

**If you are in any doubt about the electrical supply to your machine, consult a qualified electrician before use.**

**CE Marking certifies that this appliance conforms to the following EEC directives :**

**Low Voltage Equipment - 73/23/EEC & 93/68 EEC**

**Electromagnetic Compatibility 89/336/EEC, 92/31/EEC & 93/68/EEC**

# GET TO KNOW YOUR APPLIANCE

## **A** Temperature control

This knob is used to regulate the temperature of the refrigerator. The following settings are available:

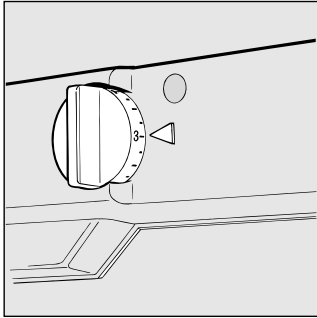

- refrigerator OFF;
- 1 minimum cold temperature;
- 5 maximum cold temperature

## **B** Container with Lid for Butter, Small Tins and Tubes

## **C** Door Shelf with Egg Compartment

## **D** Tiltable Door Shelf

## **E** Sliding Bottle Divider

## **F** Door Shelf for Holding Bottles

## **G** Fruit and Vegetable Crisper

## **H** Drain for Defrost Water

## **I** Removable, Height-adjustable Shelves

## **J** Internal Light Button

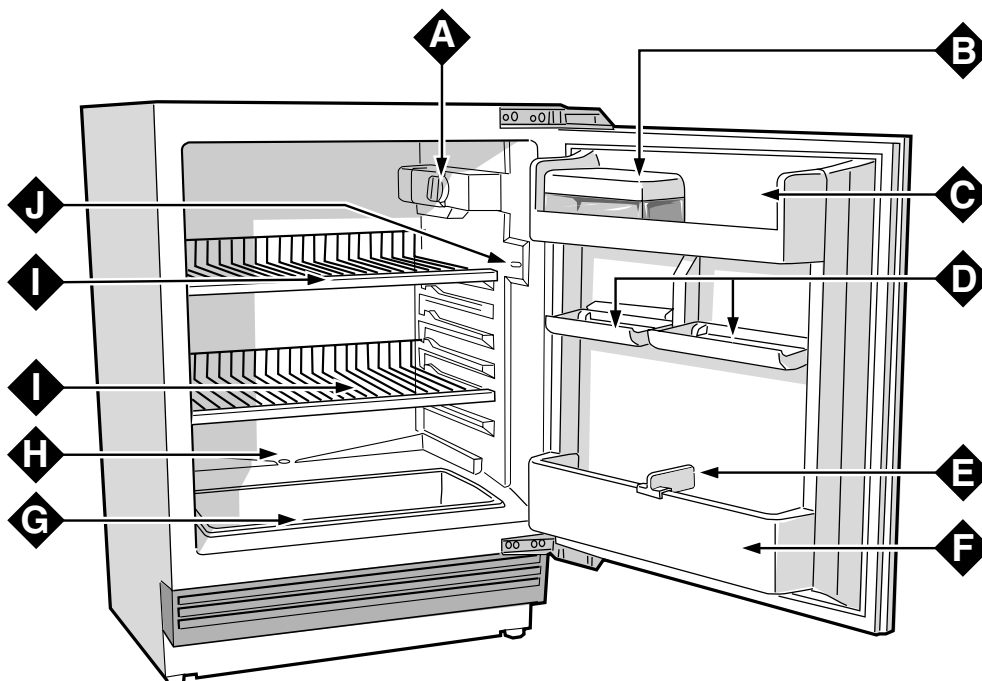

# GETTING YOUR APPLIANCE READY FOR USE

## NOTICE

After the appliance has been delivered, leave it to stand in its upright position for approximately 3 hours, before plugging it into the mains and switching on, to ensure proper performance.

Before placing food in the refrigerator or freezer, clean the interior well with warm water and baking soda.

After plugging the appliance into the socket, make sure that the light is on inside the appliance. Then turn the temperature control (A) to the "3" setting. After a few hours, you can place fresh food in the refrigerator.

## How to use the Refrigerator...

The temperature control automatically regulates the temperature inside the appliance

1 = minimum cold temperature

5 = maximum cold temperature

It is recommended that a medium setting be used.

To increase the amount of space, optimize arrangement and improve appearance, this appliance has a "cooling area" located within the back panel of the refrigerator compartment. When the appliance is operating, this panel may be covered with frost or droplets of water depending on whether the compressor is operating or not.

Do not be concerned about this!

The refrigerator is operating normally.

If the temperature control is positioned on higher settings while the refrigerator is heavily filled and the ambient temperature high, the appliance may run continuously, resulting in the formation of frost on the back cooling area. This will lead to an increase in energy consumption.

**To avoid this situation, just turn the temperature control to a lower setting so that the appliance defrosts automatically.**

### Storing Food in the Refrigerator:

| Food   | Storage Time | Location in Refrigerator  |
|--|--------------|---|
| Wrapped meat and cleaned fish (use cling film or pack in plastic bags).  | 2 or 3 days  | On the shelf above the vegetable crisper (which is the coldest area). |
| Fresh cheese   | 3 or 4 days  | On the shelf above the vegetable crisper (which is the coldest area). |
| Eggs   | 1 month      | In special egg rack on door.  |
| Butter, margarine  |              | On any shelf.   |
| Cooked or pre-cooked food (packed in air-tight containers and when cool store in refrigerator).  | 3 or 4 days  | On any shelf.   |
| Sausages, salami, sandwich meats in general, fresh pasta, custards, puddings, chocolates, cream pastries, bread, dry pastries, red tomatoes, | 3 or 4 days  | On any shelf.   |
| Bottled products, milk drinks, yoghurt.  |              | On special door shelves.  |
| Fruits and vegetables.   |              | In fruit and vegetable crisper.                                       |

### What Not to Store in the Refrigerator

Garlic (transmits odour), onions and leeks.

Bananas (they will turn black).

Citrus fruits.

Potatoes and root vegetables (store in dark, dry places).



- The air circulates naturally, with the colder air falling because it is heavier. This is the reason why meat and cheeses should be placed above the vegetable crisper.
- Please follow our instructions carefully on maximum storage time: any food, even the freshest, will not remain edible for any extended amount of time.
- Contrary to popular belief, cooked foods do not store any longer than raw food.
- Do not place liquids in containers without covering them because this will lead to an increase in the level of moisture within the refrigerator, causing the formation of frost.
- Be careful not to place containers (plastic or glass), food or other objects in direct contact with the cooling area of the back wall of the refrigerator. This could harm the food, increase energy consumption and facilitate the formation of condensate (on food, containers, etc.).
- The refrigerator compartment is equipped with convenient, removable shelves (Fig. 1) which can be adjusted for height using the shelf guides. This allows you to place even large containers and foodstuffs in the refrigerator.

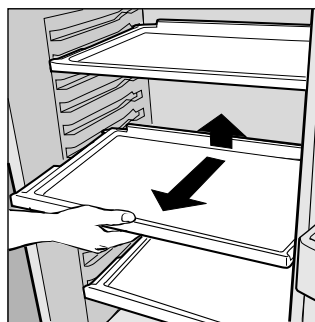

Fig. 1

## ENERGY SAVING TIPS

### - Install the Appliance Properly

In other words, away from sources of heat and direct sunlight, in a well ventilated room.

### - Correct Temperature Settings

Set the temperature control to one of the middle settings. Very cold temperature settings will not only consume a great deal of energy but will neither improve nor lengthen the storage life of the food. Excessively cold temperatures may ruin vegetables, cold cuts and cheese.

### - Do not Overfill your Appliance

Remember that proper storage of food requires good air circulation. Overfilling your appliance will hamper proper air circulation and overwork the compressor.

### - Close the Doors

Open your refrigerator only when necessary, remember that every time you open the door, most of the cold air will be lost. To bring the temperature back to the proper level again, the motor must run for a considerable amount of time, consuming a substantial amount of energy.

### - Check the Door Seal

Keep the seal clean and make sure that they adhere well to the door. This alone will ensure that no cold air escapes.

### - No Hot Foods

A container of hot food placed in the refrigerator will increase the temperature significantly. Allow food to cool before storing.

# CARING FOR YOUR APPLIANCE

Before doing any cleaning, disconnect the appliance from the electricity (by pulling out the plug or turning off the general switch in your home).

## Defrosting

**WARNING: do not damage the refrigeration circuit. Do not use mechanical devices or instruments other than those recommended by the manufacturer to speed up the defrosting process.**

### How to Defrost the Refrigerator

The evaporator defrosts automatically during operation. The defrost water is collected by the conveyor and is evaporated externally automatically.

Clean the defrost water drain hole periodically (fig. 2). This will prevent the water collecting on the bottom of the refrigerator instead of flowing out.

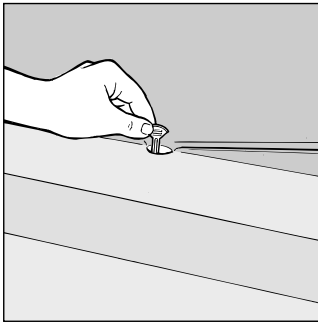

Fig. 2

## Cleaning and Special Maintenance

**Before cleaning the refrigerator, switch off and remove the plug from the socket.**

- Your appliance is manufactured with hygienic, odourless materials. To preserve these characteristics, always use sealed containers to store foods, in order to prevent spills which could stain and cause unpleasant, difficult to remove odours.

- Use a water and bicarbonate solution to clean the appliance. Clean the interior and exterior with a sponge soaked in warm water and a sodium bicarbonate solution, which is, among other things, a good disinfectant. If you do not have any in the house, you can use a neutral soap.

- DO NOT use abrasive detergents, bleach or detergents containing ammonia. NEVER use solvent based products.

- All removable parts should be taken out and soaked in warm soapy water or detergent. Rinse and dry them thoroughly before putting them back in the appliance.

- When the appliance is not used for a long time, remember to clean the interior and dry thoroughly, leave the doors open to prevent the formation of mould and unpleasant odors.

- Replacing the light bulb. The bulb for lighting the interior of the refrigerator is located at the back of the thermostat box. When replacing the lamp, unplug the appliance from the electrical socket, unscrew the burned out lamp and replace it with another with a wattage no higher than 15W (fig. 3).

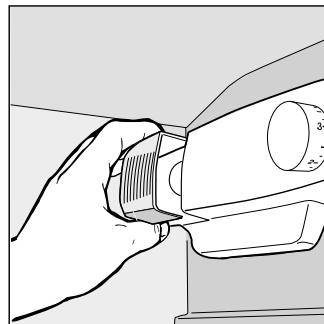

Fig. 3



# TROUBLESHOOTING

## Nothing works.

### Check that:

- The mains switch in your home is on.
- There has not been a power cut.
- The plug is properly inserted in the socket and is switched on.
- The socket is working; try another appliance in the socket to check.
- The fuse in the plug is ok - if not replace it, (see ELECTRICAL CONNECTION).

## The refrigerator does not cool properly.

### Check that:

- The door is shut properly.
- The seal is clean and not damaged.
- The door has not been left open too long.
- The temperature control is on the correct setting.
- The refrigerator or freezer is not overfilled.

## The food in the refrigerator becomes too cold.

### Check that:

- The temperature control is on the correct setting;
- The food is not in contact with the back wall - which is the coldest part.

## The motor runs continuously.

### Check that:

- The door is shut properly or has not been left open too long;
- The room temperature is not too high;
- The temperature control is not set too high.

## The appliance makes too much noise.

The refrigerant in the cooling circuit causes a slight bubbling sound, even when the compressor is not running (this is quite normal and is not a fault).

### Check that:

- The appliance is level.
- The appliance was installed between cabinets or objects that vibrate and make noise.

## There is water on the bottom of the refrigerator.

### Check that:

- The defrost drain is clear from any blockage (see fig.2).

If after all the checks, the appliance still does not operate or the problem persists, call Creda Service (see KEY CONTACTS, back page) and inform them of:

- the type of problem
- the abbreviation of the model name (Mod.) and the relative numbers (S/N)

Information can be found on the rating plate, located at the bottom left next to the fruit and vegetable crisper.

More Troubleshooting information and general product advice can be found on our website at:  
[www.theservicecentre.co.uk](http://www.theservicecentre.co.uk)

**Never call on unauthorized technicians and always refuse spare parts which are not originals.**



## Recycling & Disposal Information

As part of Creda's continued commitment to helping the environment, we reserve the right to use quality recycled components to keep down customer costs and minimise material wastage.

Please dispose of packaging and old appliances carefully.

To minimise risk of injury to children, remove the door, plug and cut mains cable off flush with the appliance. Dispose of these parts separately to ensure that the appliance can no longer be plugged into a mains socket and the door cannot be locked shut.

# NOTES

# NOTES

# Key Contacts

## Service

Creda has the largest appliance manufacturer's service team in Europe, trained specialists directly employed by us to ensure your complete confidence.

## Repair Service

UK: 08709 066 066

Republic of Ireland: 1850 302 200

You will be asked for the following information:-

Name, address and postcode.

Telephone number

Model / Serial number of the appliance

Clear and concise details of the query or fault

Place and Date of purchase

(Please keep the receipt as evidence will be required when the engineer calls).

## Extended Warranty

To join: UK 08709 088 088

Republic of Ireland: 1850 502 200

## Genuine Parts & Accessories Mail Order Hotline

UK: 08709 077 077

Republic of Ireland: (01) 842 6836

For further product information 08701 546474

General product advice can also be found on our website at:

[www.theservicecentre.co.uk](http://www.theservicecentre.co.uk)

All Creda Services are offered as an extra benefit and do not affect your statutory rights.



General Domestic Appliances Limited, Morley Way, Peterborough, PE2 9JB.

## Free Manuals Download Website

<http://myh66.com>

<http://usermanuals.us>

<http://www.somanuals.com>

<http://www.4manuals.cc>

<http://www.manual-lib.com>

<http://www.404manual.com>

<http://www.luxmanual.com>

<http://aubethermostatmanual.com>

Golf course search by state

<http://golfingnear.com>

Email search by domain

<http://emailbydomain.com>

Auto manuals search

<http://auto.somanuals.com>

TV manuals search

<http://tv.somanuals.com>