

Functional Summary

The CLS-EXP-DIMFLV enables the expansion of the Crestron® iLux™ Integrated Lighting System and other Crestron lighting dimmers to support 120 - 277 Volt loads up to 16 Amps. It allows any output channel of a compatible dimmer or switch to control a fully loaded circuit of 0-10 VDC fluorescent ballasts¹, non-dimmed lighting (incandescent, HID, magnetic low voltage (MLV), electronic low voltage (ELV), neon/cold cathode, and fluorescent ballast) up to 16 amps, and motors rated up to 1/2 HP @ 120 Volts, 1 HP @ 230/277 Volts.

The CLS-EXP-DIMFLV is designed for mounting to a vertical surface. Conduit knockouts are provided on the bottom and lower sides. All connections are made via screw terminals behind the front cover.

- Works with Crestron iLux (CLS(I)-C6), CLW-Series dimmers^{2,3}, CLX-Series dimmers³, and DIN-1DIMU4³
- Emulates the characteristics of the dimmer that is controlling it
- Up to five Expansion Modules can be connected to a single iLux dimmer channel
- Supports 0-10 VDC fluorescent, non-dimmed lighting (including HID), and motors rated up to 1 HP
- Built-in air gap relay at the output

1. Ballasts must comply with the specifications for control by DC voltage in ANSI C82.11:2002 and IEC60929:2006.
2. CLW-Series devices must have a dedicated neutral.
3. The CLS-EXP-DIMFLV can only be controlled by forward-phase dimmer modules. It is not compatible with the CLX(I)-IDELV4. If connected to a DIN-1DIMU4, the DIN-1DIMU4 must be set to operate as a forward-phase dimmer or a non-dimming switch.

CLS-EXP-DIMFLV Physical View

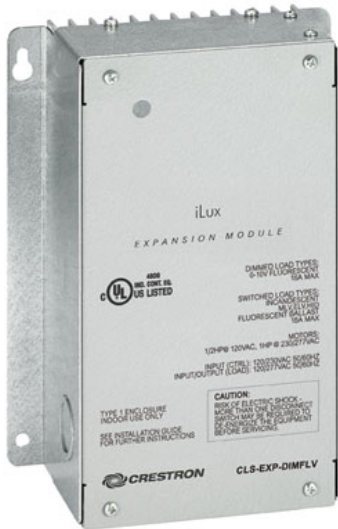

Specifications

CLS-EXP-DIMFLV Specifications

SPECIFICATION	DETAILS
Load Ratings	
Output Channels	1
Load Ratings:	
Lamp	16 Amps @ 120 – 277 Volts (70 mA max current sink for 0-10 VDC ballasts)
Motor	1/2 HP @ 120 Volts, 1 HP @ 230/277 Volts
Minimum Load	
at 120 Volts	15 Watts
at 230 Volts	25 Watts
at 277 Volts	30 Watts
Load Types	Dimmable Loads 0-10 VDC dimmable fluorescent ballasts (i.e. Advance Mark 7 or other ballasts that are compliant with the specifications for control by DC voltage in ANSI C82.11:2002 and IEC60929:2006) Non-Dim Loads Incandescent, HID, magnetic low voltage (MLV), electronic low voltage (ELV), neon/cold cathode, and fluorescent ballasts Motors Up to 1 HP @ 230/277 Volts
Input Voltages	
Line Power	120 to 277 Volts AC, 50/60 Hz
Control Input	120 or 230 Volts AC, 50/60 Hz, phase independent of line power and load, presents 25 Watts load to the controlling device
Electrical Terminals	Captive screw type; Accommodates two 22-12 AWG (0.34-4.0 mm ²) wires
Enclosure	Surface mount module with (2) integral mounting flanges, galvanized steel w/gray matte powder coat front panel, extruded aluminum heat sink, 1/2" and 3/4" conduit knockouts provided on bottom and lower left & right sides
Environmental	
Temperature	32° to 104°F (0° to 40°C)
Humidity	10% to 90% RH (non-condensing)
Maximum Heat Dissipation	68 BTU/Hr
Dimensions	
Height	8.82 in (22.40 cm)
Width	6.39 in (16.23 cm)
Depth	3.18 in (8.08 cm)
Weight	3.3 lbs (1.5 kg)

(Continued on following page)

CLS-EXP-DIMFLV Specifications (Continued)

SPECIFICATION	DETAILS
Compatible Control Devices	
CLX(I)-C6 Series	iLux Integrated Lighting System
CLW Series	Wall Dimmers and Switches
CLX(I)-1DIM4	Four Channel Dimmer Module, Single Feed
CLX-1DIM8	Eight Channel Dimmer Module, Single Feed
CLX(I)-2DIM2	Two Channel Dimmer Module, Two Feeds
CLX(I)-2DIM8	Eight Channel Dimmer Module
DIN-1DIMU4	Crestron Green Light™ DIN Rail Universal Dimmer
Maximum Expansion Modules per Controller Output	5

Industry Compliance

This product is Listed to applicable UL Standards and requirements by Underwriters Laboratories Inc.

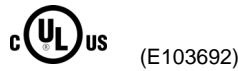

As of the date of manufacture, the CLS-EXP-DIMFLV has been tested and found to comply with specifications for CE marking.



NOTE: This device complies with part 15 of the FCC rules. Operation is subject to the following two conditions: (1) this device may not cause harmful interference and (2) this device must accept any interference received, including interference that may cause undesired operation.

This equipment has been tested and found to comply with the limits for a Class B digital device, pursuant to part 15 of the FCC Rules. These limits are designed to provide reasonable protection against harmful interference in a residential installation. This equipment generates, uses and can radiate radio frequency energy and if not installed and used in accordance with the instructions, may cause harmful interference to radio communications. However, there is no guarantee that interference will not occur in a particular installation. If this equipment does cause harmful interference to radio or television reception, which can be determined by turning the equipment off and on, the user is encouraged to try to correct the interference by one or more of the following measures:

- Reorient or relocate the receiving antenna.
- Increase the separation between the equipment and receiver.
- Connect the equipment into an outlet on a circuit different from that to which the receiver is connected.
- Consult the dealer or an experienced radio/TV technician for help.

Application

The following diagram shows several CLS-EXP-DIMFLV modules in a typical application.

CLS-EXP-DIMFLV modules in a lighting application

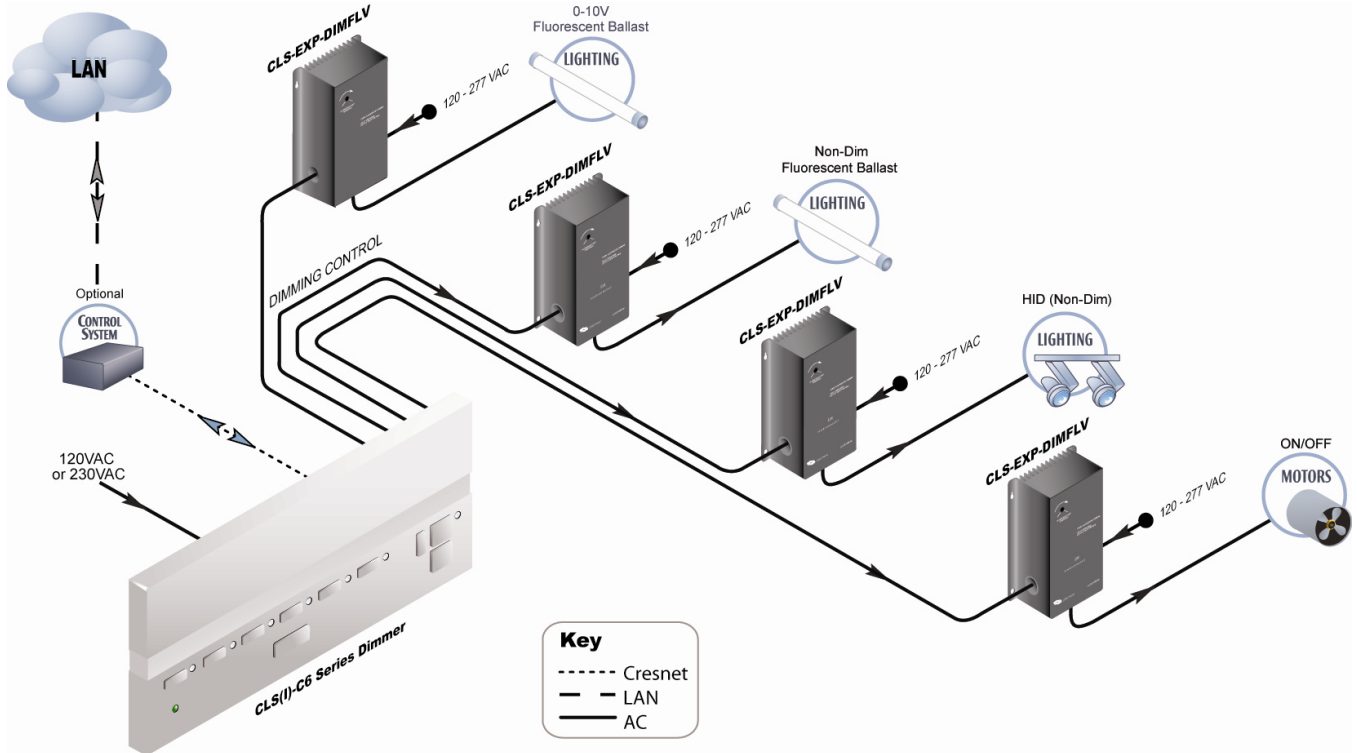

Physical Description

This section provides information on the connections and indicators available on the CLS-EXP-DIMFLV.

CLS-EXP-DIMFLV Overall Dimensions

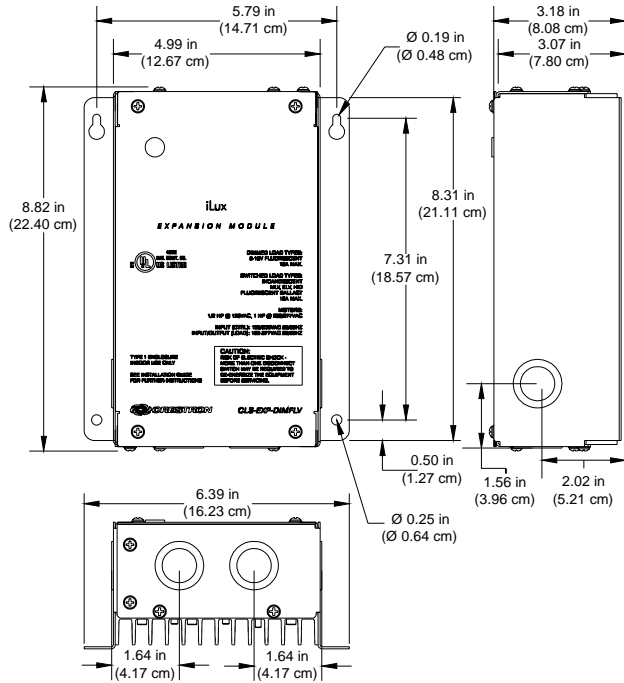

CLS-EXP-DIMFLV (cover removed)

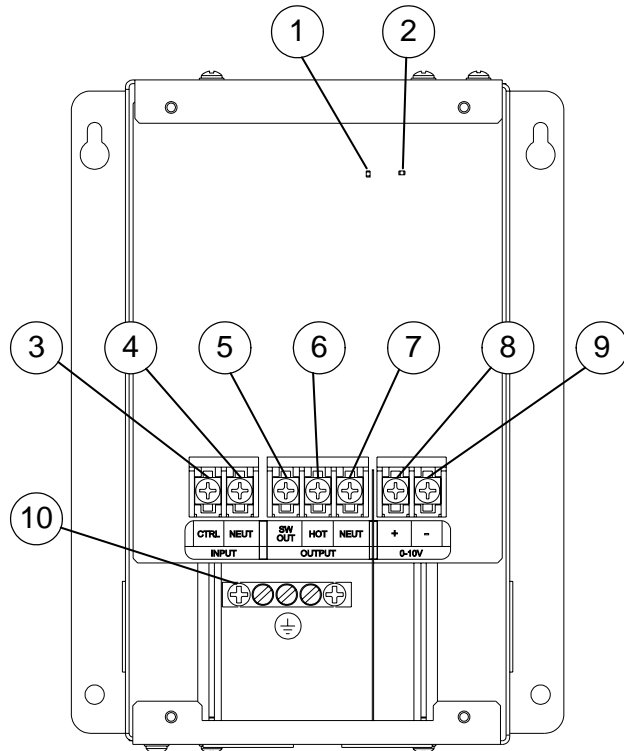

Connectors & Indicators

#	CONNECTORS & INDICATORS	DESCRIPTION
1	LOAD STATE INDICATOR	(1) Red LED behind front panel, illuminates when load output is on
2	POWER INDICATOR	(1) Green LED behind front panel, indicates power is applied to the HOT terminal
3	CTRL	(1) Captive screw terminal, for control input from compatible dimmer or switch
4	NEUT (INPUT)	(1) Captive screw terminal, for neutral connection for control input
5	SW OUT	(1) Captive screw terminal for switched output to the load
6	HOT	(1) Captive screw terminal, for line power input
7	NEUT (OUTPUT)	(1) Captive screw terminal, neutral connection for line power input and load
8	+	(1) Captive screw terminal, "+" connection to dimmable ballast
9	-	(1) Captive screw terminal, "-" connection to dimmable ballast
10	GROUND	(1) Chassis ground bus bar

Setup

Important Notes

Read before installation.

- Codes: Install in accordance with all local and national electrical codes.
- Wiring: Use 75°C copper wire only.

Installation

Refer to the following diagram when installing a CLS-EXP-DIMFLV module.

Module Installation

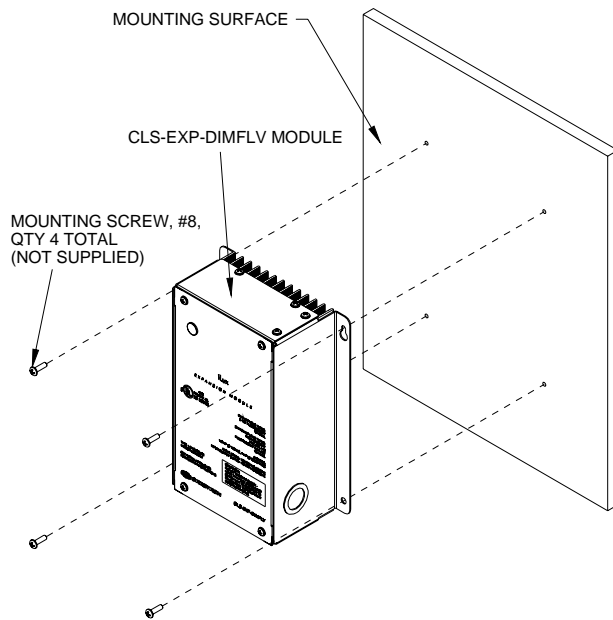

NOTE: To prevent potential heat damage to drywall, do not mount the CLS-EXP-DIMFLV directly onto drywall. Mount a piece of 1/2" (minimum) thick plywood between the CLS-EXP-DIMFLV and the drywall.

NOTE: To ensure proper ventilation, the device must be installed vertically on a vertical surface. Install device with 6 inches (15.2 cm) of clearance from the top and bottom of the device.

Hardware Hookup

WARNING: RISK OF SERIOUS PERSONAL INJURY. Turn off power at the circuit breaker(s) prior to installation. Installing with power on can result in serious personal injury and damage to the device.

1. Use a #2 Philips screwdriver to remove the cover screws as shown in the following diagram and remove the cover.

Remove Cover Screws

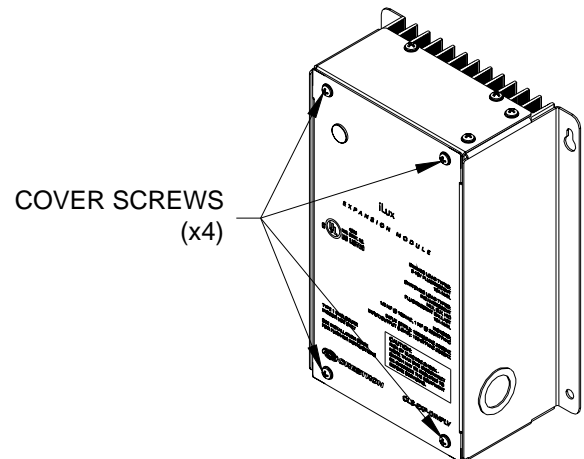

2. Depending on the module's application, select the appropriate configuration from one of the wiring diagrams on the next page and connect the CLS-C6 and load(s) as shown.
 - Wires should be stripped to 7/16" (1.1 cm)
 - Tighten terminal screws to 7 in-lbs (0.79 Nm)
 - When wiring a 0-10V fluorescent dimmer, the + and - terminals can be wired as Class 1 or Class 2. If wired as Class 1, the barrier between the **NEUT** and + terminals can be removed.

NOTE: Dimmer channels controlling one or more CLS-EXP-DIMFLV modules must not be wired to control any other type of load.

NOTE: While these diagrams show a CLS-C6 as the controlling source, other Crestron products such as CLW-Series wall dimmers (Cresnet® and infiNET™), and CLX-Series dimming modules can be used as well. Please refer to "Specifications" on page 1 for detailed information.

NOTE: When using a CLW-Series wall dimmer, the wall dimmer must be wired with a dedicated neutral wire.

CLS-EXP-DIMFLV Wiring for 0-10V Dimming

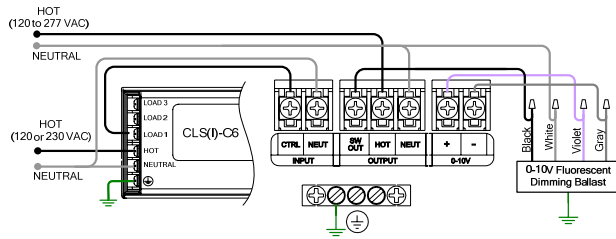

CLS-EXP-DIMFLV Wiring for Switching Application

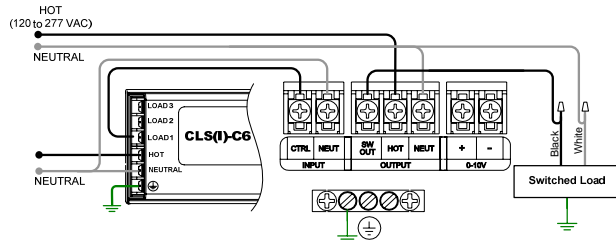

3. Apply power to the line/load and turn on the controlling device. The power indicator LED will light indicating that power is supplied to the module.
4. Replace the cover and cover screws.

Problem Solving

Troubleshooting

The following table provides corrective action for possible trouble situations. If further assistance is required, please contact a Crestron customer service representative.

CLS-EXP-DIMFLV Troubleshooting

TROUBLE	POSSIBLE CAUSE(S)	CORRECTIVE ACTION
Load does not turn on.	Controlling dimmer or switch is not working.	Make sure the controller is powered on, and is one of the compatible dimmers listed in "Specifications" on page 1.
	No power applied to HOT terminal.	Check circuit breaker. Check that green power LED on inside of unit is lit.
Load turns on and off, but will not dim.	Controlling unit is either not a dimmer, or has been set to non-dim.	Verify that dimmer is compatible with the CLS-EXP-DIMFLV (refer to "Specifications" on page 1). Verify that the controlling channel has not been programmed as non-dim.
Lights do not dim properly.	Using an incompatible dimmer.	Make sure that the dimmer is one of those listed in "Specifications" on page 1.

Further Inquiries

If you cannot locate specific information or have questions after reviewing this guide, please take advantage of Crestron's award winning customer service team by calling the Crestron corporate headquarters at 1-888-CRESTRON [1-888-273-7876].

You can also log onto the online help section of the Crestron website (www.crestron.com/onlinehelp) to ask questions about Crestron products. First-time users will need to establish a user account to fully benefit from all available features.

Return and Warranty Policies

Merchandise Returns / Repair Service

1. No merchandise may be returned for credit, exchange or service without prior authorization from CRESTRON. To obtain warranty service for CRESTRON products, contact an authorized CRESTRON dealer. Only authorized CRESTRON dealers may contact the factory and request an RMA (Return Merchandise Authorization) number. Enclose a note specifying the nature of the problem, name and phone number of contact person, RMA number and return address.
2. Products may be returned for credit, exchange or service with a CRESTRON Return Merchandise Authorization (RMA) number. Authorized returns must be shipped freight prepaid to CRESTRON, 6 Volvo Drive, Rockleigh, N.J. or its authorized subsidiaries, with RMA number clearly marked on the outside of all cartons. Shipments arriving freight collect or without an RMA number shall be subject to refusal. CRESTRON reserves the right in its sole and absolute discretion to charge a 15% restocking fee plus shipping costs on any products returned with an RMA.
3. Return freight charges following repair of items under warranty shall be paid by CRESTRON, shipping by standard ground carrier. In the event repairs are found to be non-warranty, return freight costs shall be paid by the purchaser.

CRESTRON Limited Warranty

CRESTRON ELECTRONICS, Inc. warrants its products to be free from manufacturing defects in materials and workmanship under normal use for a period of three (3) years from the date of purchase from CRESTRON, with the following exceptions: disk drives and any other moving or rotating mechanical parts, pan/tilt heads and power supplies are covered for a period of one (1) year; touchscreen display and overlay components are covered for 90 days; batteries and incandescent lamps are not covered.

This warranty extends to products purchased directly from CRESTRON or an authorized CRESTRON dealer. Purchasers should inquire of the dealer regarding the nature and extent of the dealer's warranty, if any.

CRESTRON shall not be liable to honor the terms of this warranty if the product has been used in any application other than that for which it was intended or if it has been subjected to misuse, accidental damage, modification or improper installation procedures. Furthermore, this warranty does not cover any product that has had the serial number altered, defaced or removed.

This warranty shall be the sole and exclusive remedy to the original purchaser. In no event shall CRESTRON be liable for incidental or consequential damages of any kind (property or economic damages inclusive) arising from the sale or use of this equipment. CRESTRON is not liable for any claim made by a third party or made by the purchaser for a third party.

CRESTRON shall, at its option, repair or replace any product found defective, without charge for parts or labor. Repaired or replaced equipment and parts supplied under this warranty shall be covered only by the unexpired portion of the warranty.

Except as expressly set forth in this warranty, CRESTRON makes no other warranties, expressed or implied, nor authorizes any other party to offer any warranty, including any implied warranties of merchantability or fitness for a particular purpose. Any implied warranties that may be imposed by law are limited to the terms of this limited warranty. This warranty statement supersedes all previous warranties.

Trademark Information

All brand names, product names and trademarks are the sole property of their respective owners. Windows is a registered trademark of Microsoft Corporation. Windows95/98/Me/XP/Vista and WindowsNT/2000 are trademarks of Microsoft Corporation.

This page is intentionally left blank.

Free Manuals Download Website

<http://myh66.com>

<http://usermanuals.us>

<http://www.somanuals.com>

<http://www.4manuals.cc>

<http://www.manual-lib.com>

<http://www.404manual.com>

<http://www.luxmanual.com>

<http://aubethermostatmanual.com>

Golf course search by state

<http://golfingnear.com>

Email search by domain

<http://emailbydomain.com>

Auto manuals search

<http://auto.somanuals.com>

TV manuals search

<http://tv.somanuals.com>