

MDX50

SPECIFICATIONS

HAMECH

Pneumatic Tire Lift Trucks

LPG, GAS and DIESEL
15,400 – 18,000 LB CAPACITIES



MDX50 PNEUMATIC TIRE LIFT TRUCKS

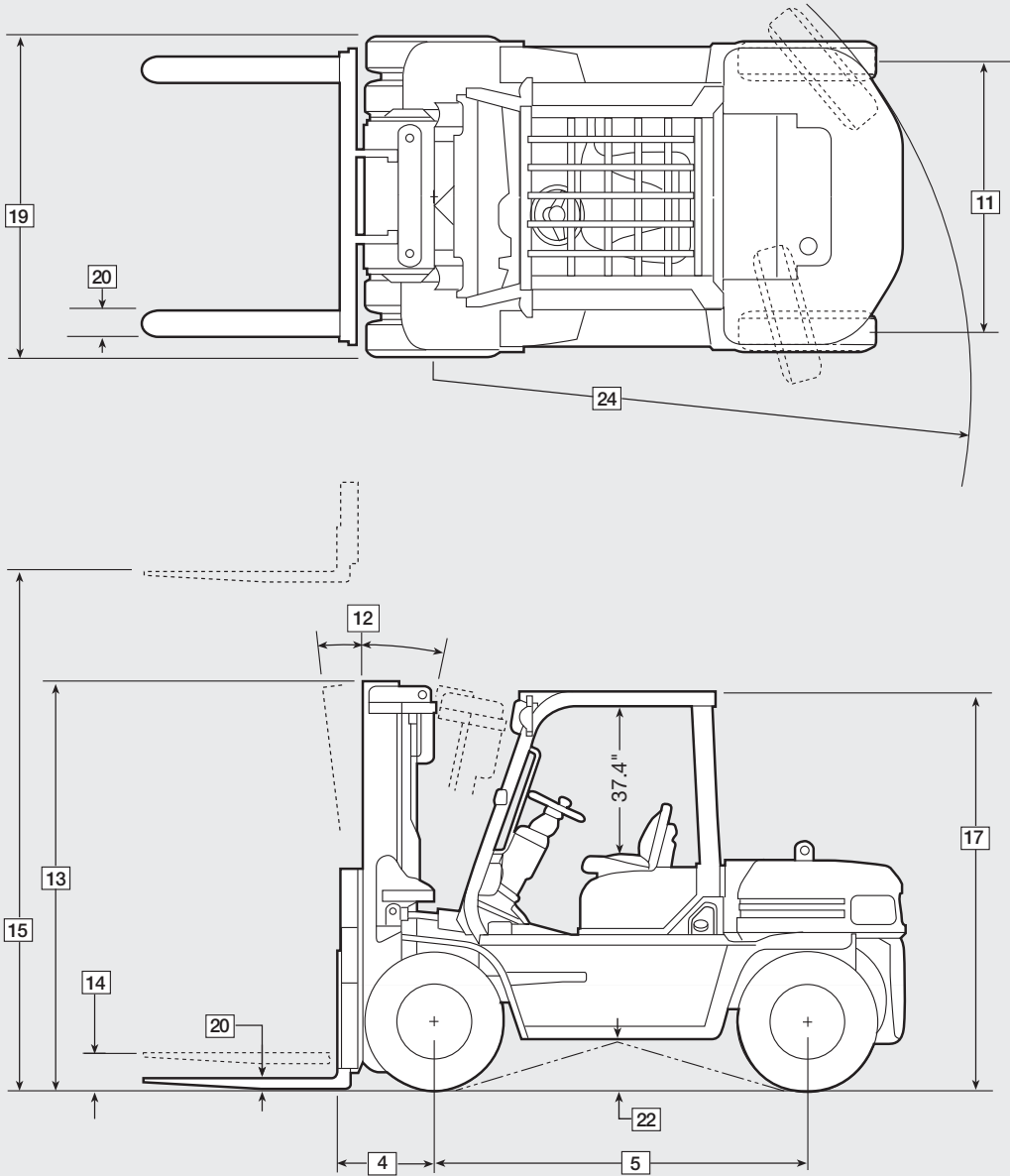

MDX50 PNEUMATIC TIRE LIFT TRUCK SPECIFICATIONS

GENERAL				D70-8	G70-8	D80-8
1	Power Type			Diesel	Gasoline	Diesel
2	Operation Type			Sit-Down	Sit-Down	Sit-Down
3	Rated Capacity*	lbs. (kg)		15,400 (7000)	15,400 (7000)	18,000 (8000)
(Capacity 600 mm 24 inch Load center)						
4	Load Distance (From Center of Front Axle)	in. (mm)		23.0 (585)	23.0 (585)	26.6 (675)
5	Wheelbase	in. (mm)		90.5 (2300)	90.5 (2300)	98.4 (2500)
WEIGHT						
6	Service Weight			20,380 (9245)	19,950 (9050)	24,240 (10995)
7	Loaded	Front	lbs. (kg)	31,590 (14330)	31,490 (14289)	37,520 (17020)
		Rear	lbs. (kg)	4,220 (1915)	3,890 (1765)	4,350 (1975)
	Unloaded	Front	lbs. (kg)	8,210 (3725)	8,110 (3680)	10,680 (4845)
		Rear	lbs. (kg)	11,510 (5220)	11,840 (5370)	13,560 (6150)
TIRE						
8	Tire Type			Pneumatic	Pneumatic	Pneumatic
9	Tire Size	Front		8.25-15-14PR (I)	8.25-15-14PR (I)	9.00-20-12PR (I)
		Rear		8.25-15-14PR (I)	8.25-15-14PR (I)	9.00-20-12PR (I)
10	Number of Wheel - Front/Rear (x=driven)			4x/2	4x/2	4x/2
11	Tread, (center of tires)	Front	in. (mm)	57.1 (1450)	57.1 (1450)	60.6 (1540)
		Rear	in. (mm)	64.6 (1640)	64.6 (1640)	66.9 (1700)
DIMENSIONS						
12	Tilting Angle (Forward/Backward)			6/12	6/12	6/12
13	Mast Height, Lowered with Std. Mast			101.8 (2585)	101.8 (2585)	106.7(2710)
14	Std. Free Lift with Std. Mast from Ground			8.7 (220)	8.7 (220)	8.7 (220)
15	Max. Fork Height**			118 (3000)	118 (3000)	118 (3000)
16	Mast Height, Extended with Std. Mast			171.2 (4350)	171.2 (4350)	171.2 (4350)
17	Height, Overhead Guard			96.1 (2440)	96.1 (2440)	102.7 (2610)
18	Length, to fork face			140.3 (3565)	140.3 (3565)	152.5 (3875)
19	Width, at tire			77.2 (1960)	77.2 (1960)	83.5 (2120)
20	Forks (Thickness x Width x Length)			2.5 x 5.9 x 48.0 (65 x 150 x 1220)	2.5 x 5.9 x 48.0 (65 x 150 x 1220)	2.5 x 6.7 x 48.0 (65 x 170 x 1220)
21	Width, Fork Carriage (Max./Min.)			66.9/11.8 (1700/300)	66.9/11.8 (1700/300)	70.9/13.4 (1800/340)
22	Ground Clearance	Under the Mast	in. (mm)	8.8 (225)	8.8 (225)	9.8 (250)
		at the center of wheelbase	in. (mm)	11.2 (285)	11.2 (285)	13.2 (335)
23	Right Angle Stacking Aisle †			210.8 (5355)	210.8 (5355)	224.2 (5695)
24	Turning Radius			131.9 (3350)	131.9 (3350)	141.7 (3600)
PERFORMANCE						
25	Travel Speed (FWD)	Loaded, 1st/2nd	mph (km/h)	6.8 (11.0)/18.6 (30.0)	6.8 (11.0)/17.4 (28.0)	7.5 (12.0)/19.3 (31.0)
		Unloaded, 1st/2nd	mph (km/h)	7.5 (12.0)/19.9 (32.0)	7.5 (12.0)/19.9 (32.0)	7.8 (12.5)/20.5 (33.0)
26	Lifting Speed (Loaded/Unloaded)			89/98 (450/500)	72/77 (365/390)	90/98 (455/500)
27	Lowering Speed (Loaded/Unloaded)			108/98 (550/500)	108/108 (550/550)	98/89 (500/450)
28	Max. Drawbar Pull (Loaded 1.5km/h, 3min rating)			10,350 (46.1)	9,470 (42.1)	12,950 (57.6)
29	Max. Gradeability (Loaded 1.5km/h, 3min rating)			29.8	24.2	32.7
30	Service Brake			Hydraulic, Powered	Hydraulic, Powered	Hydraulic, Powered
31	Parking Brake			Mechanical	Mechanical	Mechanical
32	Steering			Power Steering	Power Steering	Power Steering
DRIVE						
33	Make/Model			KOMATSU S6D102E	NISSAN TB45E	KOMATSU SA6D102E
34	Rated Output/Speed, SAE gross	HP (kW) @rpm		103 (77)@2250	95 (70)@2400	129 (96)@2250
35	Max. Torque/Speed, SAE gross	lb. - ft. (N-m) @ min-1		289 (392)@1000	203 (276)@1600	344 (466)@1600
36	Number of Cylinder/Displacement			6/359 (5880)	6/273 (4478)	6/359 (5880)
OTHER						
37	Fuel Tank Capacity			37 (140)	37 (140)	37 (140)
38	Relief Pressure for Attachment			2,630 (181)	2,630 (181)	2,630 (181)
39	Hydraulic Tank Capacity			18 (70)	18 (70)	18 (70)
40	Clutch			Torque Converter	Torque Converter	Torque Converter
41	Transmission			TORQFLOW	TORQFLOW	TORQFLOW
42	Battery (Voltage/Capacity at 5-hour rating)			V/Ah 24/52	12/48	24/52

NOTE: Most values shown in this publication are rounded. Therefore, direct conversion between metric and English or Imperial may be slightly different from those shown. The performance of machines is affected by the condition of the truck and how it is equipped, as well as the nature and condition of the operating area.

If these specifications are critical or if your needs exceed the specifications shown here, discuss the proposed application with your authorized dealer.

*Optional masts, attachments, longer load dimensions, and higher lifting heights may result in downrating of the capacity. Contact your authorized dealer.

**Other mast heights available. See MAST DATA chart for other standard mast heights. Contact your authorized dealer.

†Add load distance and clearance. Contact your authorized dealer.

MDX50 TRUCK DATA AND FEATURES

Maximum Fork Height in. (mm)	Overall Height		*Load Capacity lbs. (kg)	Free Lift in. (mm)	Back Tilt Restriction	
	Lowered in. (mm)	Extended in. (mm)				
D70-8 / G70-8 2-STAGE VIEW MAST**						
118 (3000)	101.8 (2585)	171.3 (4350)	15,400 (7000)	8.7 (220)	12°	
138 (3500)	111.6 (2835)	190.9 (4850)				
157 (4000)	121.4 (3085)	210.6 (5350)				
177 (4500)	135.2 (3435)	230.3 (5850)				
197 (5000)	149.0 (3785)	250.0 (6350)				
217 (5500)	162.8 (4135)	269.7 (6850)				
236 (6000)	172.6 (4385)	289.4 (7350)	14,770 (6700)			
236 (6000)	172.6 (4385)	289.4 (7350)	14,330 (6500)			
D70-8 / G70-8 2-STAGE FULL FREE VIEW MAST***						
118 (3000)	101.8 (2585)	165.7 (4210)	14,550 (6600)	57.3 (1455)	10°	
130 (3300)	107.7 (3735)	177.6 (4510)		63.2 (1605)		
138 (3500)	111.6 (2835)	185.4 (4710)		67.1 (1705)		
157 (4000)	121.5 (3085)	205.1 (5210)		77.0 (1955)		
D70-8 / G70-8 3-STAGE FULL FREE VIEW MAST***						
157 (4000)	94.5 (2400)	201.0 (5105)	14,110 (6400)	55.3 (1405)	6°	
169 (4300)	98.4 (2500)	212.8 (5405)		59.3 (1505)		
177 (4500)	100.4 (2550)	220.5 (5600)		61.4 (1560)		
197 (5000)	108.3 (2750)	240.2 (6100)		13,890 (6300)		69.3 (1760)
217 (5500)	116.1 (2950)	259.8 (6600)		13,450 (6100)		77.2 (1960)
236 (6000)	124.0 (3150)	279.5 (7100)	12,130 (5500)	85.0 (2160)		

Note: Standard mast is shown in broad frame.

*Load capacity at 24in. (600mm) load center.

**50.4 in. (1280mm) height load backrest.

***Free lift and Overall height (Extended) shown are for truck without load backrest.

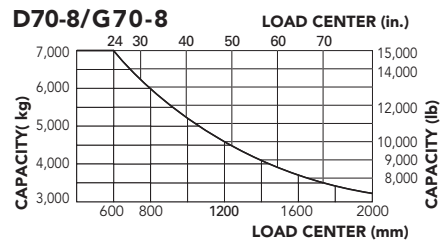

Note: Capacities shown are for trucks equipped with 2-stage view mast up through 197in. (5000mm) maximum fork height, 66.9in. (1700mm) carriage, 48in. (1220mm) forks. Contact your distributor or dealer for capacity information with other equipment.

Maximum Fork Height in. (mm)	Overall Height		*Load Capacity lbs. (kg)	Free Lift in. (mm)	Back Tilt Restriction	
	Lowered in. (mm)	Extended in. (mm)				
D80-8 2-STAGE VIEW MAST**						
118 (3000)	106.7 (2710)	171.3 (4350)	17,640 (8000)	8.7 (220)	12°	
138 (3500)	116.5 (2960)	190.9 (4850)				
157 (4000)	126.4 (3210)	210.6 (5350)				
177 (4500)	140.2 (3560)	230.3 (5850)				
197 (5000)	153.9 (3910)	250.0 (6350)				
217 (5500)	167.7 (4260)	269.7 (6850)				
236 (6000)	177.6 (4510)	289.4 (7350)	16,980 (7700)			
236 (6000)	177.6 (4510)	289.4 (7350)	16,530 (7500)			
D80-8 2-STAGE FULL FREE VIEW MAST***						
118 (3000)	106.5 (2705)	164.6 (4180)	17,420 (7900)	63.1 (1605)	10°	
130 (3300)	112.4 (2855)	176.4 (4480)		69.1 (1755)		
138 (3500)	116.3 (2955)	184.3 (4680)		73.0 (1855)		
157 (4000)	126.2 (3205)	203.9 (5180)		82.9 (2105)		
D80-8 3-STAGE FULL FREE VIEW MAST***						
157 (4000)	102.6 (2605)	209.3 (5315)	15,870 (7200)	55.1 (1400)	6°	
169 (4300)	106.5 (2705)	221.1 (5615)		59.1 (1500)		
177 (4500)	108.5 (2755)	228.9 (5815)		61.0 (1550)		
197 (5000)	116.3 (2955)	248.6 (6315)		15,400 (7000)		68.9 (1750)
217 (5500)	124.2 (3155)	268.3 (6815)		14,330 (6500)		76.8 (1950)
236 (6000)	132.1(3355)	288.0 (7315)		13,010 (5900)		84.6 (2150)

Note: Standard mast is shown in broad frame.

*Load capacity at 24in. (600mm) load center.

**50.4 in. (1280mm) height load backrest.

***Free lift and Overall height (Extended) shown are for truck without load backrest.

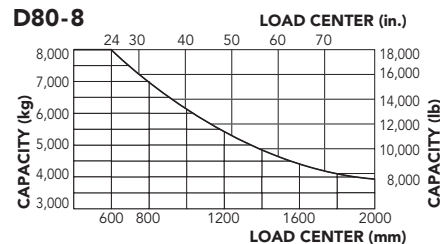

Note: Capacities shown are for trucks equipped with 2-stage view mast up through 197in. (5000mm) maximum fork height, 66.9in. (1700mm) carriage, 48in. (1220mm) forks. Contact your distributor or dealer for capacity information with other equipment.

FEATURES AND EQUIPMENT

SPECIAL FEATURES

- The NissanTB45E LPG/Gas and Komatsu S6D102E diesel industrial engines deliver exceptional power, emission control, and reliable operation for enhanced productivity and fuel efficiency.
- Full floating operator compartment (HSC) greatly reduces operator fatigue by isolating the compartment from engine and traveling vibrations.
- Swing up engine cover, lift out floor plate and radiator cover provide quick access for daily checks and maintenance.
- Wide slip resistant steps and assist hand grip makes entry and exit easier.
- Dash display provides easy to read information to the operator and maintenance personnel.

STANDARD EQUIPMENT

- Dash Display – Fuel, Water Temperature, Torque Converter oil temperature and Hour Meter Gauges
- Drawbar Pin
- Electronic Ignition; Anti-Restart Ignition Switch
- Engine Oil Pressure and Charge Warning Lamps
- Fully Hydrostatic Power Steering
- Headlights – OHG Mounted
- High Air Intake in OHG
- Horn
- Deluxe full suspension vinyl seat and Operator Restraint System with Lap Belts
- Load Backrest
- Overhead Guard
- Sedimeter warning light (Diesel Units)
- Tilting Steering Column
- Torque Converter Oil Cooler
- Turn Signal, Back-up, Stop and Tail Lights

OPTIONAL EQUIPMENT

- Warning Devices – Audible
- Warning Devices – Visual
- Rear View Mirrors
- Additional Length Forks
- Attachments
- Auxiliary Hydraulic Valve
- Internal Hydraulic Hosing

ENGINE

TB45E 6 cylinder in-line, 4.5 liter with ECCS (Engine Concentrated Control System) engine to meet the next generation of low emission standards. This new low RPM high torque industrial engine offers a higher level of engineering excellence through exceptional emission controls, acceleration, performance, reliability, and serviceability.

- Three choices: gasoline with multi-port fuel injection, or LPG with single-port (throttle body) fuel injection, or a dual-fuel operation easily switching between fuels with the flip of a switch. All trucks are equipped with a 3-way catalytic converter.
- All engines utilize an ECCS that continuously monitors engine component data from the accelerator pedal, throttle position, mass-air-flow, water temperature, fuel pressure, and heated oxygen sensor, for increased sensitivity, reliable cold starts, and smooth performance throughout the operating range. An electronic governor is used for rev-limit protection.
- Temperature sensor prevents overheating during high temperature operation by automatically limiting engine speed until the coolant temperature returns to within normal operating range, if the coolant temperature exceeds a specific temperature, the engine will shut down automatically. When the engine exceeds normal operating temperature a dash displayed warning light is also illuminated.
- Aluminum-alloy head for efficient cooling.
- Additionally, the low noise level provides comfort to the operator while driving the truck. S6D102E diesel 6 cylinder in-line, 5.9 liter 4 stroke cycle turbo-charged direct injection timed engine that produces high performance and excellent fuel economy. The Komatsu S6D102E diesel engine delivers the power and efficiency to get the job done quickly and cost-effectively while meeting emission requirements.
- The starting system of quick glow spark (QGS) ensures a quicker and reliable start in all climate conditions.

FUEL SYSTEM

Gasoline, LPG, or dual-fuel system. Integral fuel (gasoline or diesel) tank.

- Liquid propane gasoline (LPG) fuel is available with (optional) 33 lb. or 43 lb. tank.

COOLING SYSTEM

Large capacity, highly efficient aluminum radiator

- Easy access reservoir tank for checking or adding coolant.
- Plastic bladed cooling fan with unequal pitched blades for additional noise reduction and efficiency.

ELECTRICAL SYSTEM

Standard operator conveniences that are optional on most, such as a complete light package, horn and hour meter, are standard on Hamech.

- 12-volt electrical system.
- Alternator with built in I.C. regulator.
- Key-lock, anti-restart ignition switch (Gas/LPG only).
- Dash displayed fuel level and water temperature gauges.
- Warning lights for engine oil pressure, battery charging, brake fluid level, ECCS monitor and operation fault indicator.
- ECCS – SST (Service Support Tool) connector interface for rapid engine diagnostics.
- Electrically controlled forward-reverse lever operates at the touch of a finger.

HYDRAULIC SYSTEM

The hydraulic system features an integral reservoir, rebuildable direct drive gear pump, and fully filtered system.

- Large capacity reservoir and radiator cooling keeps the hydraulic fluid at an efficient operating temperature.
- Load sensing valve in the hydraulic circuit halts the flow of oil to the power steering system when steering wheel is idle.

FRAME

All welded assembly of heavy gauge steel with integral hydraulic and fuel tanks.

- Flange type drive axle mounting and heavy duty engine mounts improve product reliability.

BRAKES

Hydraulic assisted service brakes with master cylinder booster are self-adjusting and self-centering.

- High friction, large diameter brake linings are housed in the drive axle.
- Enlarged brake covers prevent dirt and water from entering the linings.
- Mechanical parking brake is actuated from adjustable toggle handle on dash allowing for more legroom in the operator's compartment.

STEER AXLE

Standard on demand, Fully Hydrostatic Power Steering.

MAST, CARRIAGE, LBR & FORKS

High-visibility mast assembly with 4 or 6-roller carriage available in 2-Stage Free-View and 2-Stage or 3-Stage Full Free-View type.

- Sealed bearings for reduced maintenance with standard side thrust rollers on carriage.
- Equipped with ITA Class IV carriage bars for mounting forks or a variety of load handling attachments.
- 48-inch load backrest is standard for increased load control and operator safety.
- Single and double function internal hosing is available for operating attachments.

OPERATOR COMPARTMENT

A unique full-floating operator compartment (HSC) designed to isolate the operator from fatigue producing vibration.

- Deluxe full suspension seat with retractable seat belt, lateral restraint system, and adjustable seat travel and reclining is standard.
- Hydraulic control levers have easy-to-read international symbols on the contoured grips and are within easy reach of the operator.
- Tilting steering console positions instrument panel in full view of operator at all times.
- Floor mounted automotive-type pedals with large ribbed pads for comfort and safe operation.
- Full width floor mat provides large non-slip surface, reduces noise, vibration, and heat.
- Large open steps and convenient assist handgrip provides easy entry and exit for the operator.

- Separate inching and braking pedals provide positive control while reducing wear on the drive train.
- Trucks come standard with an integral headlight/turn indicator control. Turn indicator has automatic return to neutral.
- The overhead guard is full width and offers excellent visibility for stacking high loads.

SERVICEABILITY

Excellent access to engine compartment, transmission, and radiator areas can be achieved without tools. Making daily checks and maintenance easier.

- The gas cylinder-assisted, one-piece all metal engine compartment cover lifts easily and is insulated to reduce noise and heat.
- Cover also features a single latch for locking down and an open cover catch to prevent cover from coming down while in open position.
- Bottom corner of cover is angled to allow more access into engine compartment for scheduled maintenance and service.

COMPLIANCE & APPROVALS

Meets or exceeds American National Standards Institute, ASME B56.1 – Part III Safety Standards for Powered Industrial Trucks.

Compliant with UL 558 for the appropriate truck type. Contact your authorized dealer for application specifics. Meets or Exceeds EPA emissions standards

Expect solid support nationwide

Hamech, a brand of Crown Equipment Corporation, offers a comprehensive service support network for Hamech LPG, gas or diesel lift trucks.

You can expect ongoing value with the comprehensive services available from your Hamech dealer. See it for yourself in state-of-the-art facilities stocked with products and parts inventories, advanced processes, equipment and tools. It's also apparent in the professionally trained service technicians and well-stocked service vans.

In addition, you can count on Hamech for operator and service technician training, flexible maintenance programs, fleet management and financial services. Hamech's association with Crown also assures you of access to industry-leading electric lift trucks for complete application flexibility.

Visit hamech.com for more information on the full line of Hamech IC lift trucks.



HAMECH

Hamech Lift Trucks
New Bremen, Ohio 45869 USA
Tel 419-629-2311
Fax 419-629-3796

Hamech is a brand of Crown Equipment Corporation.

Because Hamech is continually improving its products, specifications are subject to change without notice.

Hamech and the Hamech logo are trademarks of Crown Equipment Corporation.

Copyright 2008 Crown Equipment Corporation
SF14900 03/08
Printed in U.S.A.

Free Manuals Download Website

<http://myh66.com>

<http://usermanuals.us>

<http://www.somanuals.com>

<http://www.4manuals.cc>

<http://www.manual-lib.com>

<http://www.404manual.com>

<http://www.luxmanual.com>

<http://aubethermostatmanual.com>

Golf course search by state

<http://golfingnear.com>

Email search by domain

<http://emailbydomain.com>

Auto manuals search

<http://auto.somanuals.com>

TV manuals search

<http://tv.somanuals.com>