

dacor

The life of the kitchen™

INSTALLATION INSTRUCTIONS

BUILT-IN REFRIGERATORS

TABLE OF CONTENTS

Refrigerator Safety	1	Unpack Refrigerator.....	9
Design Specifications	2-6	Anti-tip Blocking.....	9
Product Dimensions.....	2	Water Line Connection.....	10
Door Swing Dimensions.....	2	Plug in Refrigerator.....	10
Custom Overlay Panels.....	3-6	Move Unit to Final Position.....	10
Installation Specifications	7-8	Level Unit.....	10
Tools and Parts.....	7	Install Custom Panels.....	11-13
Location Requirements.....	7-8	Anchor the Unit.....	13
Electrical Requirements.....	8	Installation Check List.....	14
Water Supply Requirements.....	8	Service Information	14
Installation Instructions	9-14		

REFRIGERATOR SAFETY

What You Need to Know About Safety Instructions

Warning and Important Safety Instructions appearing in this guide are not meant to cover all possible conditions and situations that may occur. Common sense, caution and care must be exercised when installing, maintaining or operating appliance.

Always contact Dacor® about problems or conditions you do not understand.

Recognize Safety Symbols, Words, Labels

DANGER

DANGER – Immediate hazards which **WILL** result in severe personal injury or death.

WARNING

WARNING – Hazards or unsafe practices which **COULD** result in severe personal injury or death.

CAUTION

WARNING – Hazards or unsafe practices which **COULD** result in minor personal injury or property damage.

INSTALLATION RECOMMENDATIONS

The importance of the installation of the Dacor® Built-In Refrigerator cannot be overemphasized. Installation should be done by a qualified installer.

Before you begin the installation process, it is recommended that you read this entire Installation Instruction Manual. There are key details that you should take special care to observe during the installation. By reading these instructions carefully, you will make the installation process easier, problem-free and, most importantly, safe.

Any questions or problems with the installation should be directed to your Dacor® dealer or the Dacor® Customer Service Department at 800.793.0093 or email customerservice@dacorworld.com. You can also visit our website at www.dacor.com.

DESIGN SPECIFICATIONS

PRODUCT DIMENSIONS

- ◇ The depth from the front of the top grill (w/o decorator panel) to the back of the refrigerator chassis is 25 1/4" (641mm).
- ◇ The depth from the rear of the top grill to the back of the refrigerator chassis is 23 13/16" (605mm).
- ◇ The power cord is 40" (1016mm) long.
- ◇ The height from the top of the top grill to floor with the leveling legs in the down position is 83 3/8" (2118mm)
- ◇ The height from the top of the top grill to floor with the leveling legs in the fully extended position is 84 5/8" (2149mm)
- ◇ The chassis width from the chassis edge to the chassis edge for 42-inch is model 41 1/4" (1048mm), 48-inch is model 47 1/4" (1200mm).
- ◇ The overall width from the trim edge to the trim edge for 42-inch model is 42 1/16" (1068mm), 48-inch model is 48 1/16" (1221mm).

DOOR SWING DIMENSIONS

The area to the left and the right of the appliance must permit both doors to open to a minimum of 90°. Allow a minimum of 2 1/2" (64mm) space between the side of the refrigerator doors and a corner wall.

NOTE: More clearance may be required if using an overlay panel or custom handles.

DESIGN SPECIFICATIONS

CUSTOM OVERLAY PANELS

The decorator panels for overlay models cover the door trim for an attractive, seamless look that flows into the overall design of the room. This application is often accomplished by using three panels: the decorative front panel, a spacer panel of .10-inch thickness, and a 1/4-inch backer panel. (see page 4)

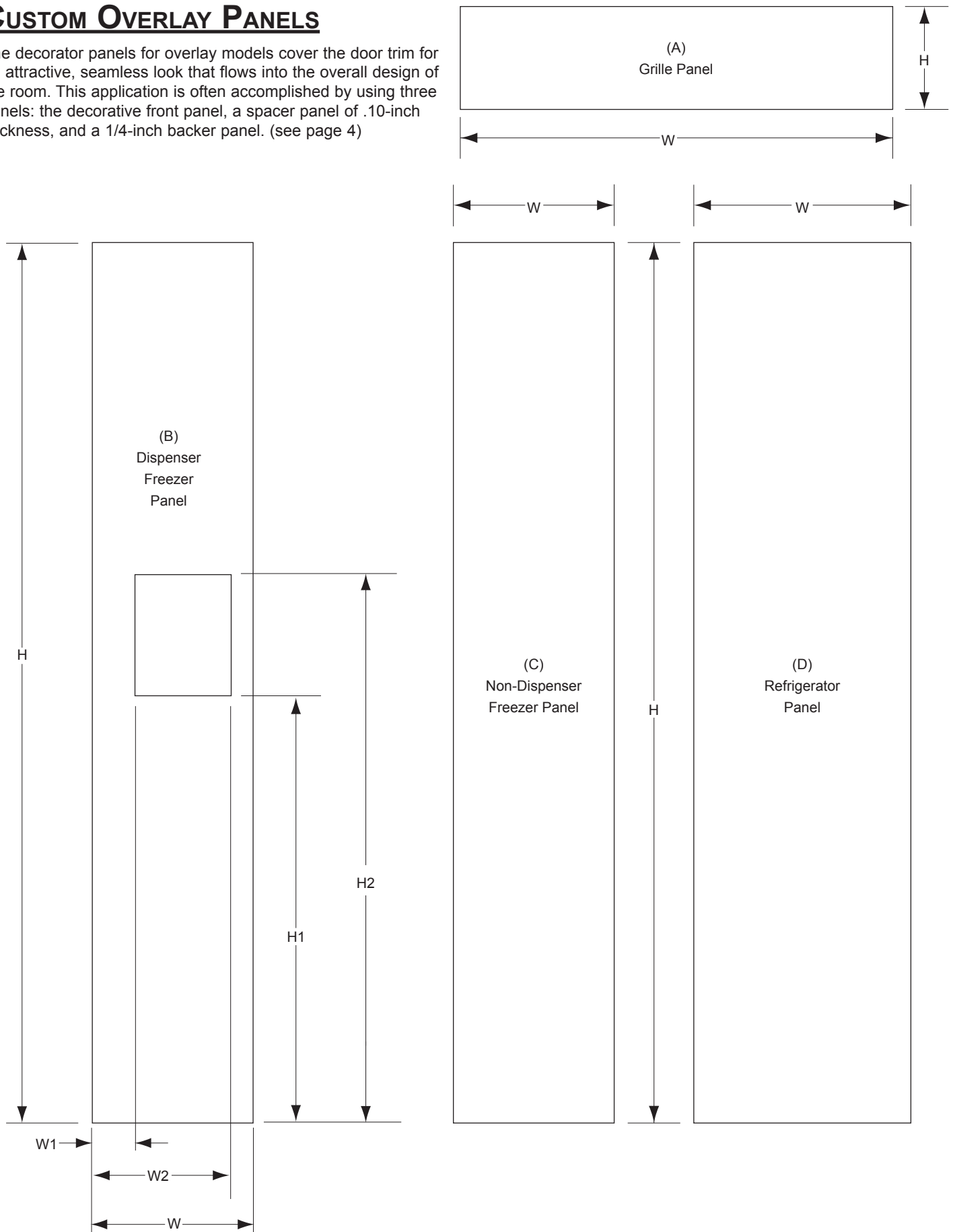

DESIGN SPECIFICATIONS

Overlay Panel Specifications

(See Illustrations on page 3.)

	42-Inch Model	48-Inch Model
BACKER PANEL		
(A) Grille Panel		
W Width	40 1/4" (1022mm)	46 1/4" (1175mm)
H Height	8 3/4" (222mm)	8 3/4" (222mm)
(B) Freezer Dispenser Panel		
W Width	16 1/4" (413mm)	18 1/2" (470mm)
W1 Width	2" (51mm)	2" (51mm)
W2 Width	14 1/2" (368mm)	14 1/2" (368mm)
H Height	69 1/8" (1756mm)	69 1/8" (1756mm)
H1 Height	34 1/16" (865mm)	34 1/16" (865mm)
H2 Height	48 1/8" (1222mm)	48 1/8" (1222mm)
(C) Freezer Non-Dispenser Panel		
W Width	16 1/4" (413mm)	18 1/2" (470mm)
H Height	69 1/8" (1756mm)	69 1/8" (1756mm)
(D) Refrigerator Panel		
W Width	23 1/2" (597mm)	27 1/4" (692mm)
H Height	69 1/8" (1756mm)	69 1/8" (1756mm)
SPACER PANEL		
(A) Grille Panel		
W Width	39 1/4" (997mm)	45 1/4" (1149mm)
H Height	7 3/4" (197mm)	7 3/4" (197mm)
(B) Freezer Dispenser Panel		
W Width	15 1/4" (387mm)	17 1/2" (445mm)
W1 Width	2" (51mm)	2" (51mm)
W2 Width	14 1/2" (368mm)	14 1/2" (368mm)
H Height	68 1/8" (1730mm)	68 1/8" (1730mm)
H1 Height	34 1/16" (865mm)	34 1/16" (865mm)
H2 Height	48 1/8" (1222mm)	48 1/8" (1222mm)
(C) Freezer Non-Dispenser Panel		
W Width	15 1/4" (387mm)	17 1/2" (445mm)
H Height	68 1/8" (1730mm)	68 1/8" (1730mm)
(D) Refrigerator Panel		
W Width	22 1/2" (572mm)	26 1/4" (667mm)
H Height	68 1/8" (1730mm)	68 1/8" (1730mm)
FRONT DECORATOR PANEL		
(A) Grille Panel		
W Width	40 1/4" (1022mm)	46 1/4" (1175mm)
H Height	8 3/4" (222mm)	8 3/4" (222mm)
(B) Freezer Dispenser Panel		
W Width	16 7/16" (418mm)	18 3/4" (476mm)
W1 Width	2 1/4" (572mm)	2 1/4" (572mm)
W2 Width	14 1/4" (362mm)	14 1/4" (362mm)
H Height	69 1/4" (1759mm)	69 1/4" (1759mm)
H1 Height	34 5/16" (872mm)	34 5/16" (872mm)
H2 Height	47 13/16" (1214mm)	47 13/16" (1214mm)
(C) Freezer Non-Dispenser Panel		
W Width	16 7/16" (418mm)	18 3/4" (476mm)
H Height	69 1/4" (1759mm)	69 1/4" (1759mm)
(D) Refrigerator Panel		
W Width	23 3/4" (603mm)	27 1/2" (699mm)
H Height	69 1/4" (1759mm)	69 1/4" (1759mm)

NOTES:

- ◇ Use counter sink screws for attaching the backer panel to the front panel.
- ◇ On 42" custom panels watch location of handle mounting due to under cut of front panel.
- ◇ For freezer dispenser front panels, remove fountain trim and tape to the backside of the backer panel. Note recycle symbol should be visible and located at the bottom.
- ◇ You may want to remove any additional material on the backer panel when used in conjunction with a front panel. Remove 1/32" on thickness and 1/2" wide of material on the inside surface of the backer panel. This will help ease assembly of the panel assembly onto the door.

Backer Panel Thickness 1/4" (6mm)

Spacer Panel Thickness 0.100" (2.5mm)

If Raised Panel is Used Overall Front Panel Thickness Not to Exceed 1 1/4" (318mm)

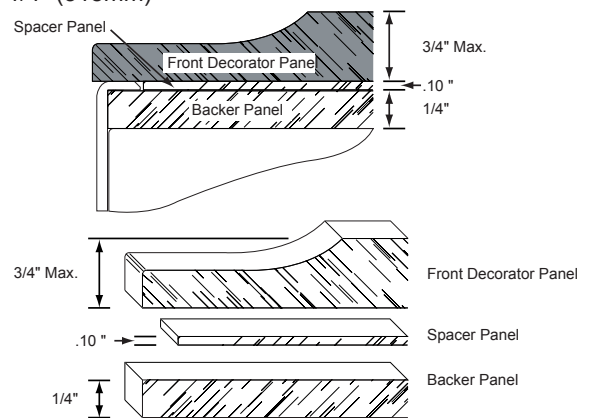

Side Panel Specifications

If using side panels with the Dacor® Built-In Refrigerator, they will need to be 1/4" (6mm) thick.

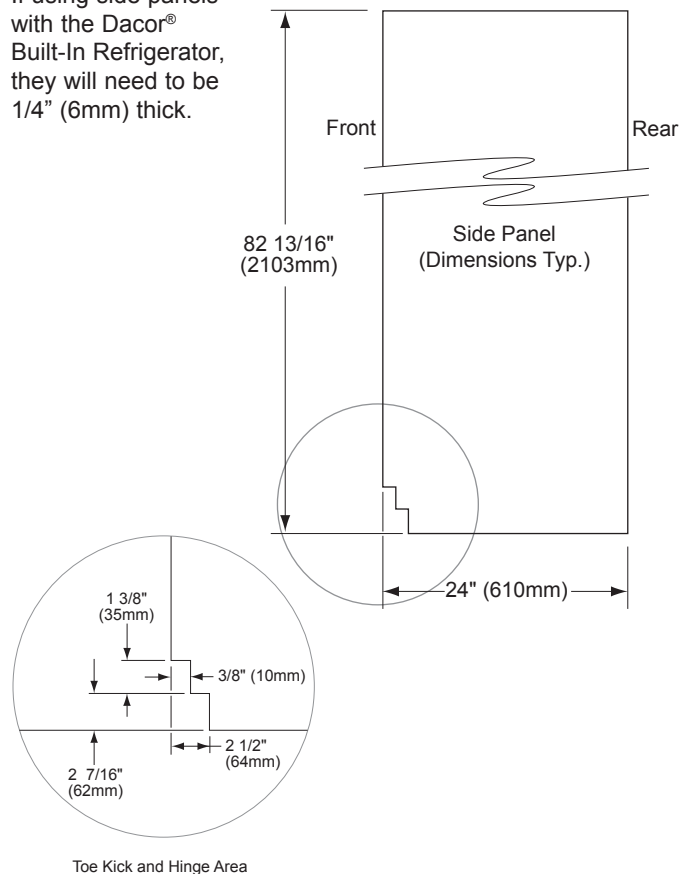

DESIGN SPECIFICATIONS

Custom Toe Kickplate Specifications

If using custom toe kickplate with your Dacor® Built-In Refrigerator, refer to the following specifications.

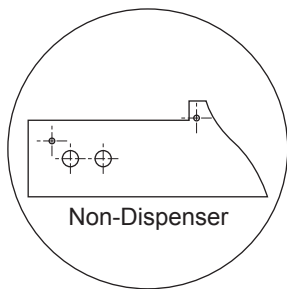
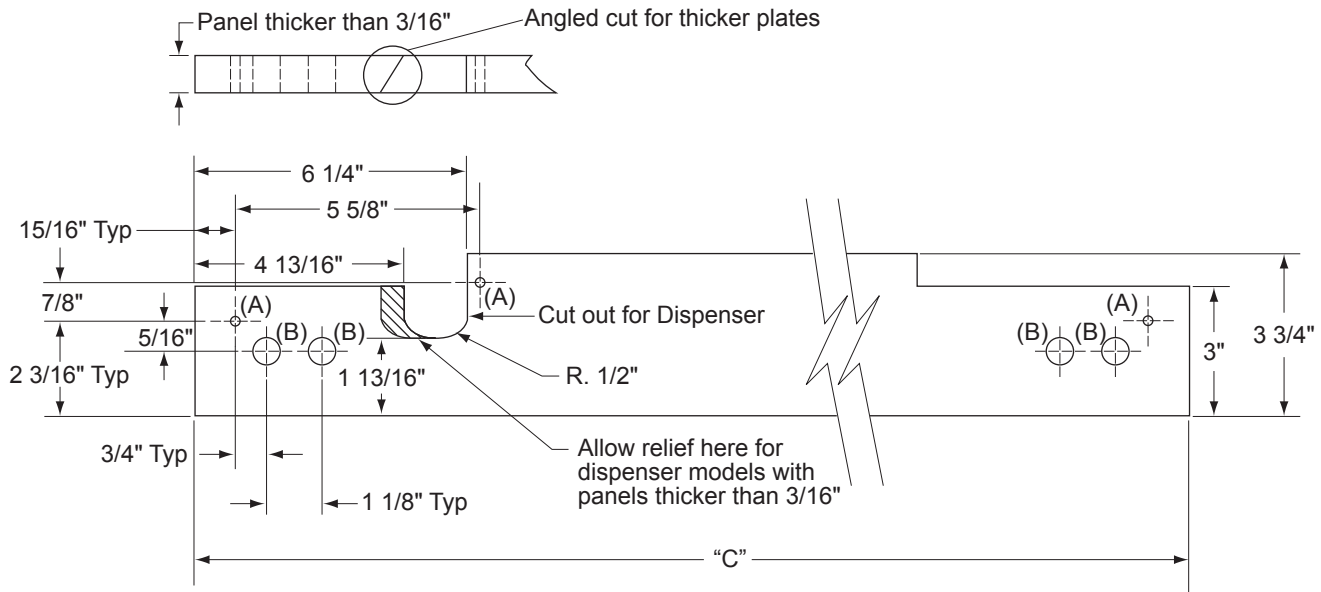

Model	Hole "A" Dia.	Hole "B" Dia.	Overall Length "C"
42-Inch	3/16" (5mm)	1/2" (13mm)	40 7/8" (1038mm)
48-Inch	3/16" (5mm)	1/2" (13mm)	46 7/8" (1191mm)

Custom Handle Specifications

Before installing the custom panel assembly, the custom handle hardware must be installed. It is recommended that handles with larger D-style pulls be used. If the screws that are used have thick heads, the screws will need to be countersunk into the panel before it is put into place.

IMPORTANT: Dacor® advises not using single pull knobs on Built-In Refrigerator.

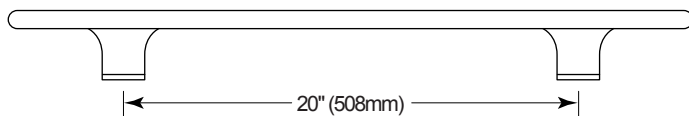

Custom Panel Door Swing Specifications

The following illustrations let you see what considerations you need to make for any custom panel applications, and how they may interact with adjacent cabinets and/or countertops.

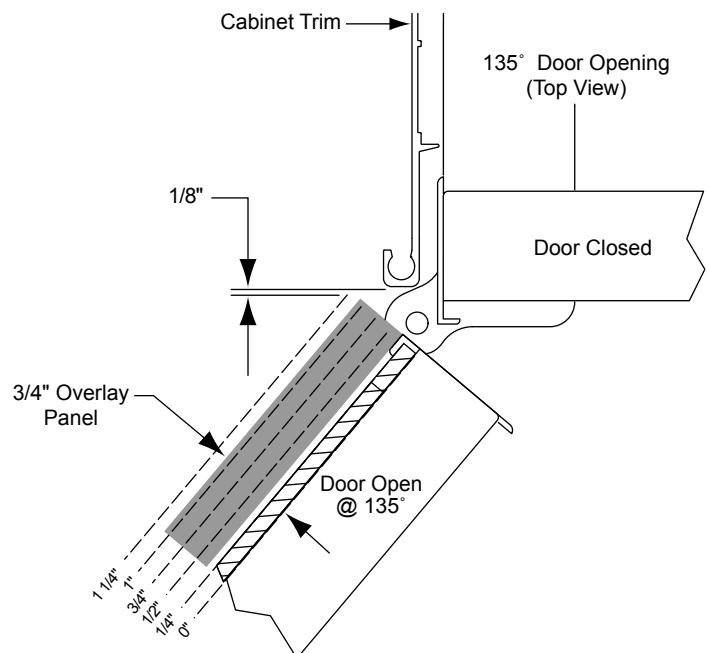

DESIGN SPECIFICATIONS

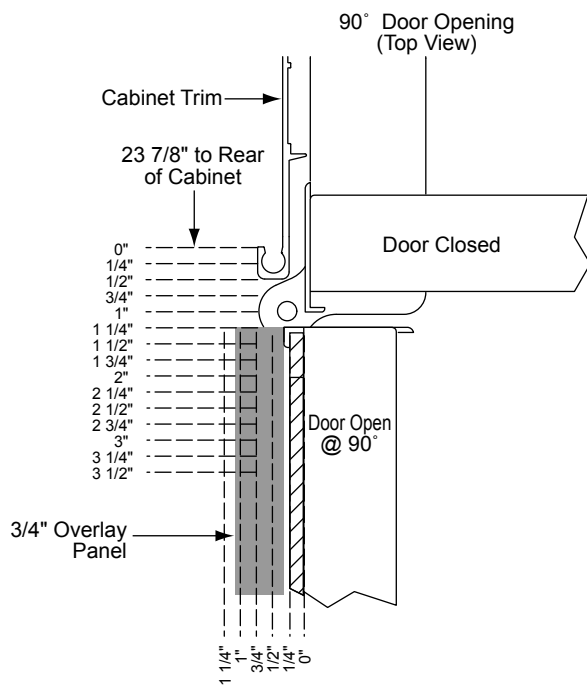

90° Door Stop

Both doors are designed to open 135°. To restrict one or both doors to a 90° opening, use the door stops supplied in this kit.

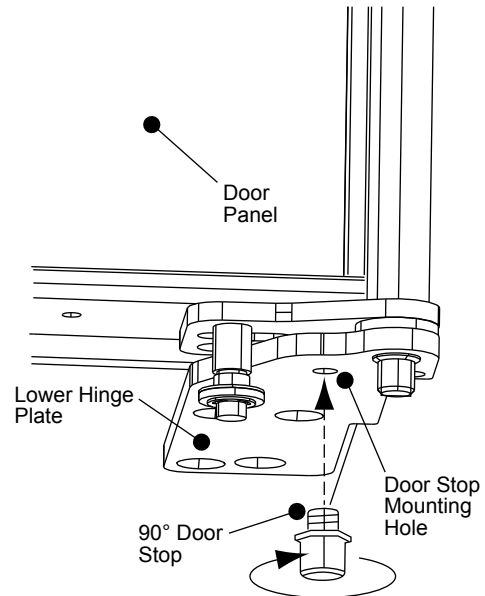

With the doors closed, screw a door stop into the underside of the lower hinge plate as illustrated above.

INSTALLATION SPECIFICATIONS

TOOLS AND PARTS

IMPORTANT:

- ◇ Installer: Leave these Installation Instructions with the homeowner.
- ◇ Homeowner: Keep these Installation Instructions for future reference. Save these Installation Instructions for the local electrical inspector's use.

Tools needed:

Make sure that you have the necessary tools and materials available for a proper installation.

- ◇ Phillips screwdriver set
- ◇ Slotted screwdriver set
- ◇ Torx drive screwdriver set
- ◇ Provide sufficient length 8' (2.4m) to allow for a minimum of a 24" (610mm) diameter service loop of 1/4" (6mm) copper tubing and saddle valve for the water line (Do not use self-piercing valves)
- ◇ Copper tubing cutter
- ◇ Level - 2' (.6m) and 4' (1.2m) recommended
- ◇ Appliance Dolly able to support 700lbs (317kg) and adequate manpower to handle the weight of the appliance
- ◇ Various sized pliers
- ◇ Allen wrench set
- ◇ 3/8" hex bolt nut driver or socket set
- ◇ Crescent wrenches
- ◇ Cordless drill and assorted drill bits
- ◇ Masonite, plywood, 1/8" pressed fiberboard, cardboard or other suitable material to protect finished flooring
- ◇ Appropriate materials to cover and protect the home and its furnishings during installation

LOCATION REQUIREMENTS

Your Dacor® refrigerator can be recessed in an opening between cabinets or installed at the end of a cabinet run using a side panel to enclose the refrigerator.

⚠ WARNING

EXPLOSION HAZARD – Keep flammable material and vapors, such as gasoline, away from refrigerator. Failure to do so can result in death, explosion, or fire.

IMPORTANT:

- ◇ Observe all governing codes and ordinances.
- ◇ Do not install the refrigerator near an oven, radiator, or other heat source, nor in a location where the temperature will fall below 55°F (13°C).
- ◇ Floor must support the refrigerator weight, more than 600lbs (272kg), door panels and contents of the refrigerator.
- ◇ Ceiling height must allow for side tipping radius.
- ◇ Location should permit doors to open fully.
- ◇ Location must permit the top grill to be opened.

Site Preparation

The solid soffit or ceiling should be within 1" (25mm) above the refrigerator. If the solid soffit is higher than 1" (25mm) or one is not available, then the refrigerator must be braced to prevent tipping during use.

If the anti-tip blocking is needed, (see "Anti-Tip Blocking" on page 9)

IMPORTANT: To operate properly, the door must open a minimum of 90°. For installation in a corner, a 2 1/2" (64mm) filler strip is required to ensure the 90° opening. The floor under the refrigerator is to be level with the surrounding floor. To protect the floor when moving the refrigerator, place cardboard, or preferably a carpet remnant (backing up) on the floor.

INSTALLATION SPECIFICATIONS

Rough-In Dimensions

- ◇ The solid soffit or ceiling should be within 1" (25mm) above the refrigerator. If the solid soffit is higher than 1" (25mm) or one is not available, then the refrigerator must be braced to prevent tipping during use. If the anti-tip blocking is need. (see "Anti-Tip Blocking" on page 9)

NOTE: A clearance of 1/2" (13mm) must be maintained above the top grill in order for the top grill to be opened.

- ◇ A grounded 3 prong non-GFCI electrical outlet should be placed 2" (51mm) from the right side cabinets or end panel. See "Electrical Requirements" for additional information.
- ◇ The plumbing for the water line can come through the floor or the back wall. See "Water Supply Requirements" for more information.

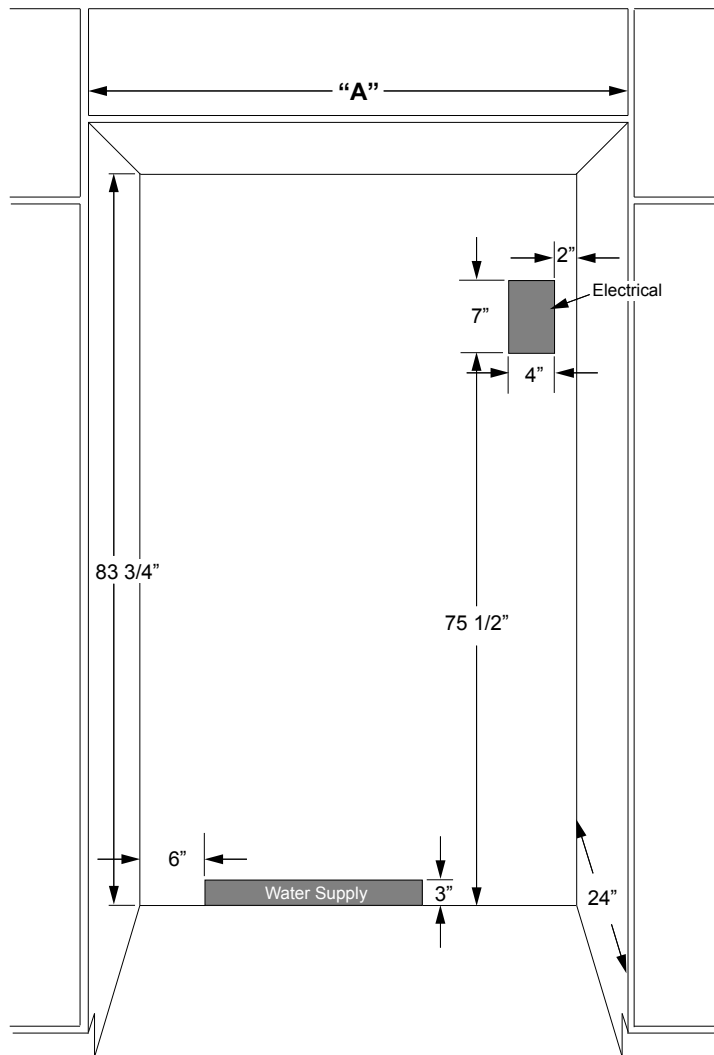

Model	Rough-In Width "A"
42-Inch	41 1/2" (1054mm)
48-Inch	47 1/2" (1207mm)

ELECTRICAL REQUIREMENTS

⚠ WARNING

ELECTRICAL SHOCK HAZARD – Plug into a grounded 3-prong non-GFCI outlet. Do not remove ground prong. Do not use an adapter. Do not use an extension cord. Failure to do so can result in death, fire, or electrical shock.

A 115VAC, 60 Hz, 15 Amp circuit breaker and electrical supply are required. A separate dedicated non-GFCI circuit, servicing only this appliance, is required.

Your Dacor® Built-In refrigerator is equipped with a 40" (1016mm) 3-prong grounded power cord, which must be plugged into a 3-prong grounding-type non-GFCI wall receptacle. Follow the National Electrical Code and local codes and ordinances when installing the receptacle. See "Rough-In Dimensions" for location of the electrical supply.

IMPORTANT: A ground fault circuit interrupter (GFCI) is not recommended and may cause interruption of operation.

WATER SUPPLY REQUIREMENTS

- ◇ All installations must meet local plumbing code requirements.
- ◇ Connect to 1/4" (6mm) copper line to the house cold fresh water supply.
- ◇ Use a shut off valve between the refrigerator and supply. The shut off valve should be a drilled saddle valve.
- ◇ Do not use a self-tapping valve which reduces water flow and clogs more easily.
- ◇ Route the water line within 3-1/2" (89mm) of the rear wall and no higher than 3" (76mm) from the floor.
- ◇ Allow a minimum of 24" (610mm) diameter service loop of copper tubing outside the wall or floor for easy connection to the water supply.

Cold water supply

Connect the ice maker to a cold water line with water pressure between 30 and 120 PSI. If you have any questions about your water pressure, call your utility company.

IMPORTANT:

- ◇ In homes with a Reverse Osmosis water treatment system, remove the water inlet connector from the "yellow" valve and attached to the "blue" valve. Make sure the water filter bypass plug is in place.

INSTALLATION INSTRUCTIONS

UNPACK REFRIGERATOR

⚠ WARNING

TIP OVER HAZARD – Refrigerator is top heavy and tips easily when not completely installed. Keep doors taped closed until refrigerator is completely installed. Use two or more people to move and install refrigerator. Failure to do so can result in death or serious injury.

IMPORTANT:

- ◇ Do not remove the protective film until the refrigerator is in its operating position.
1. Uncrate the refrigerator.
 2. Remove the lower shipping bolts and brackets.
 3. Slide the unit off of the crate base.
 4. Remove and save the lower kick plate, anti-tip brackets and mounting hardware.

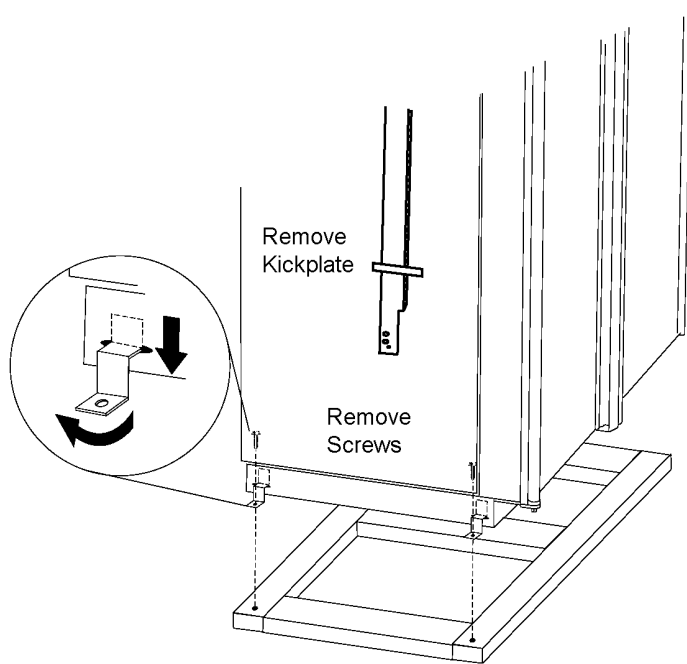

5. Place an appliance dolly under the freezer side of the refrigerator. Be sure to protect the side trims and handles. Place the corner post from the packing materials over the trims and handles as appropriate. Carefully tighten the strap.

NOTE: Avoid damaging water valves and water lines in front and back of cabinet.

6. Place protective material on the floor when rolling the dolly and refrigerator into the house. Move the unit close to the built-in opening

ANTI-TIP BLOCKING

Blocking the Refrigerator

If there is a solid soffit or ceiling above the unit and the clearance is 1" (25mm) or less you will not need to block the unit. For installations with clearances of more than 1" (25mm), you must use the anti-tipping 2x4 and brackets provided.

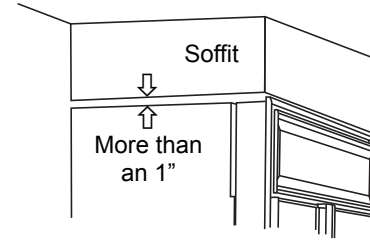

More than 1" clearance:

Use the anti-tip kit provided with the shipping crate.

1. Locate and mark the 2 wall studs behind the refrigerator.
2. Mark where the "L" brackets and the 2x4 will be located and drill two 1/8" pilot holes
3. Locate proper height to clear the unit. The space between the top of the unit and the bottom of the wood block must not exceed 1/4".
4. Secure the "L" brackets, using the provided screws, into the wall stud.
5. Align the pilot hole with the "L" brackets and secure the 2x4 with screws provided.

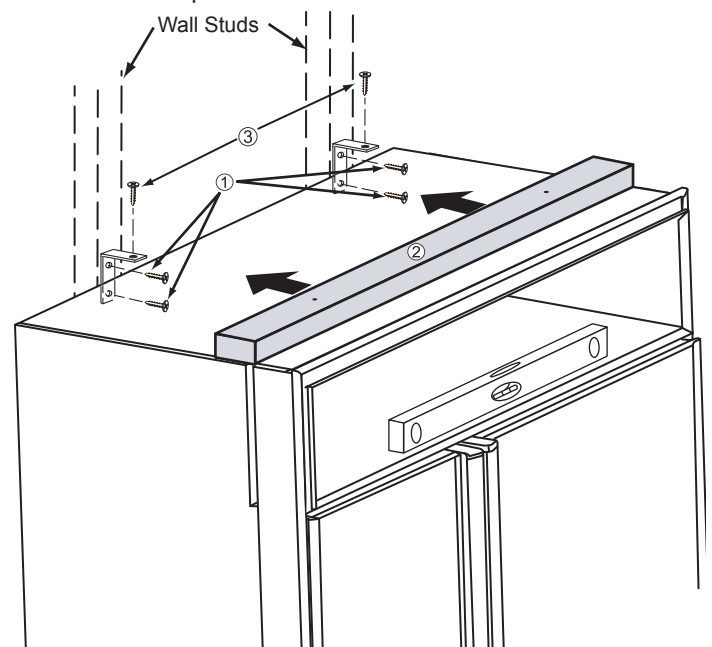

INSTALLATION INSTRUCTIONS

WATER LINE CONNECTION

- ◇ Before attaching the copper tubing to the unit, flush at least 2qt (1.9L) of water through the copper tubing into a bucket to get rid of any particles in the water line.
- ◇ Check for leaks around the saddle valve. Do not overtighten the clamp or sleeve. This will crush the copper tubing.
- ◇ Make connection to the refrigerator.
- ◇ Turn shutoff valve ON.
- ◇ Check for leaks, Tighten any nuts or connections (including connections at the valve) that leak.

PLUG IN REFRIGERATOR

⚠ WARNING

ELECTRICAL SHOCK HAZARD – Plug into a grounded 3-prong non-GFCI outlet. Do not remove ground prong. Do not use an adapter. Do not use an extension cord. Failure to do so can result in death, fire, or electrical shock.

1. Verify that the switch in the top cabinet is in the OFF position.
2. Plug into a grounded 3-prong outlet.

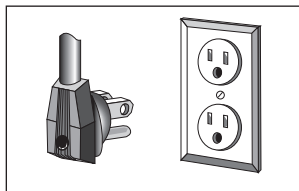

Main Power and Fahrenheit/Celsius Switches

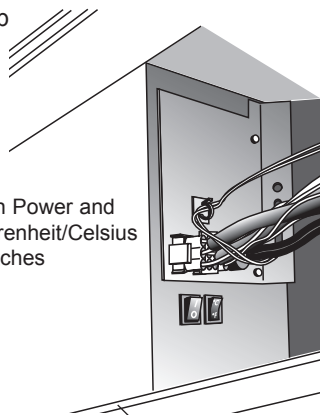

MOVE UNIT TO FINAL POSITION

IMPORTANT: To prevent floor damage, make sure levelers are raised (not touching the floor) and the unit is on rollers before moving.

- ◇ Place top of cardboard carton or plywood under refrigerator. Remove unit from dolly.
- ◇ Do not remove protective film.
- ◇ Move the refrigerator straight back and evenly into the rough opening. Verify that the water tubing is not kinked and the power cord is not kinked.

LEVEL UNIT

- ◇ Slide the unit in place and raise the front and rear levelers until the unit touches the brackets. (Use a 3/8" socket to raise and lower the unit.)
- ◇ Check to see whether the refrigerator is level left to right, by opening the doors and place a level on top of the refrigerator frame as shown.

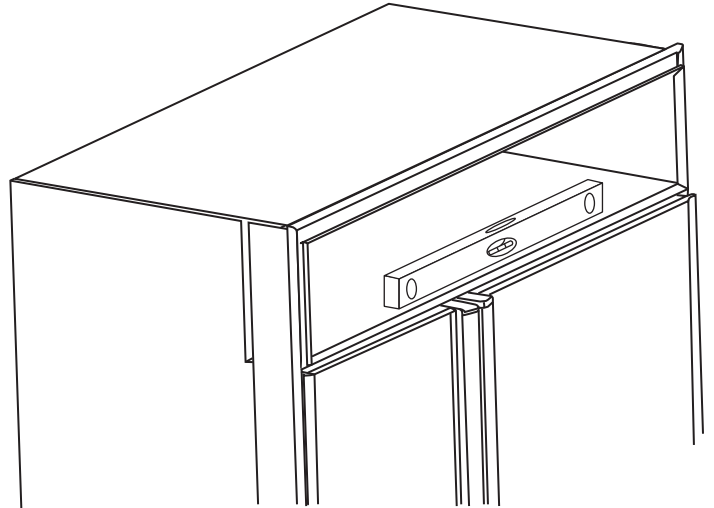

- ◇ Use the leveling bolts to adjust the leveling legs until the refrigerator is level from left to right.
- ◇ Check to see whether the refrigerator is level from front to back, by placing the level(s) on the shelf or shelves.

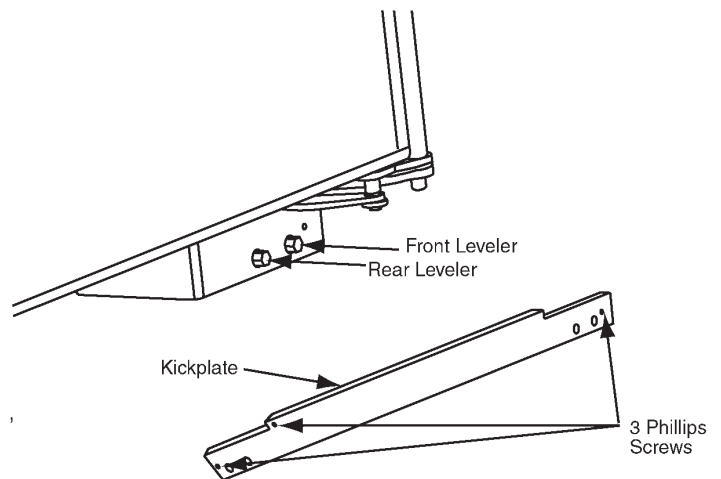

- ◇ Use the leveling bolts to adjust the leveling legs until the refrigerator is level from front to rear.
- ◇ Verify that all 4 leveling legs contact the floor and support the full weight of the refrigerator.
- ◇ Make final check to ensure that the refrigerator is level.
- ◇ Install the kickplate.

INSTALLATION INSTRUCTIONS

INSTALL CUSTOM PANELS

Panel Installation

Before you begin installing panels, refer to the "Custom Panel Specifications" for overlay models and verify that you are working with the panel design called for in your installation. If you have chosen the stainless steel design, your refrigerator has been shipped complete with a finished stainless steel front. It will not be necessary to install panels or handle hardware.

Be aware that panels used on refrigerators with the overlay design have the potential for coming into contact with adjacent cabinets and/or countertops when the refrigerator doors are opened. You will want to be mindful of the surrounding cabinetry and space limitations when planning for decorator panels. Refer to the 90° door stop information on page 6.

IMPORTANT: The weight of each panel cannot exceed 50lbs (23kg). The grille panel weight cannot exceed 10lbs (5kg).

To install overlay panels, the door trim must be removed. The trim screws are hidden by a magnet backed trim molding. Remove the molding by using the adhesive side of packing tape on the magnetic backed molding to pull it away from the trim and expose the trim screws. The molding will bend at the center so that you can remove it. See illustration below.

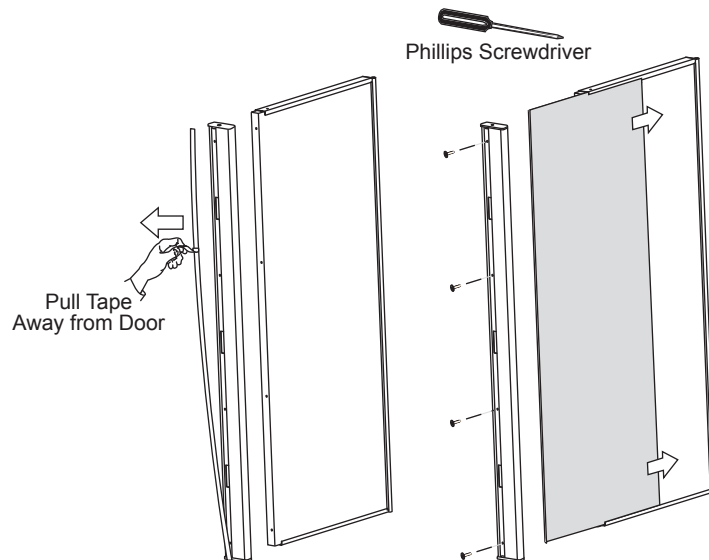

With a phillips screwdriver, remove the trim from the freezer and refrigerator doors. Slide the panel into the frame on the door. With the panel in position, replace the trim. Be sure that the panel is inserted completely into the channel for proper fit and alignment.

Replace the trim molding by inserting the top, then the bottom into the trim channel. Release the middle and set the magnets.

Panel Installation for Dispenser Models

1. Power switch needs to be off. Switch located in machine compartment area (see User Guide).
2. Remove magnetic strip on door trim. Use of tape may be required removing the magnetic strip.
3. Remove four Phillips screws to remove door trim.

(Refer to numbered illustrations for steps 4-10)

4. Remove the spill tray grille from the fountain.

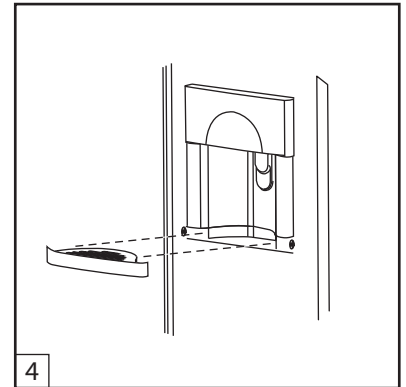

5. Remove the two #15 Torx machine screws, which retain the stainless steel splashguard. Remove the splashguard.

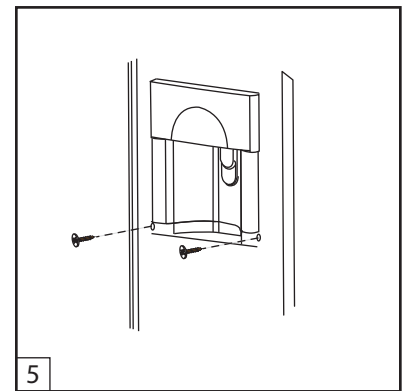

6. Remove the two #15 Torx long plastic screws that retain the fountain control panel. (Longer screws). Slide control panel down to remove. Disconnect the electrical terminals going to the fountain control panel. Tuck dispenser terminal inside to avoid interference.

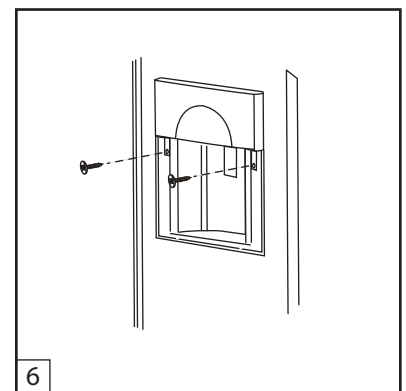

INSTALLATION INSTRUCTIONS

7. Remove the four #15 Torx plastic collar screws from the fountain/escutcheon collar.

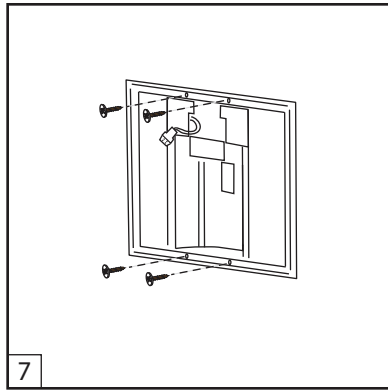

8. Place the fountain/escutcheon collar onto the backer panel. Use tape to hold in place.

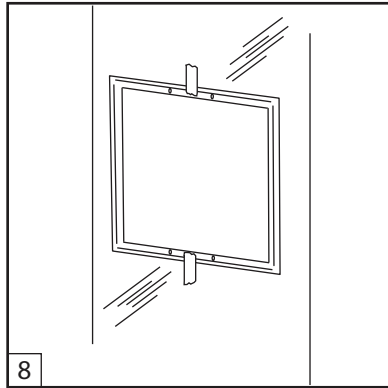

9. Open the freezer door and slide panel onto the door.

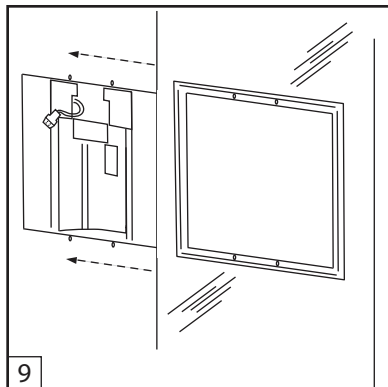

10. The holes in the fountain/escutcheon collar should line up with the mounting holes in the door panel. Reverse instructions 7 to 1 (ex. Replace the four #15 Torx plastic collar screws from the fountain escutcheon collar)

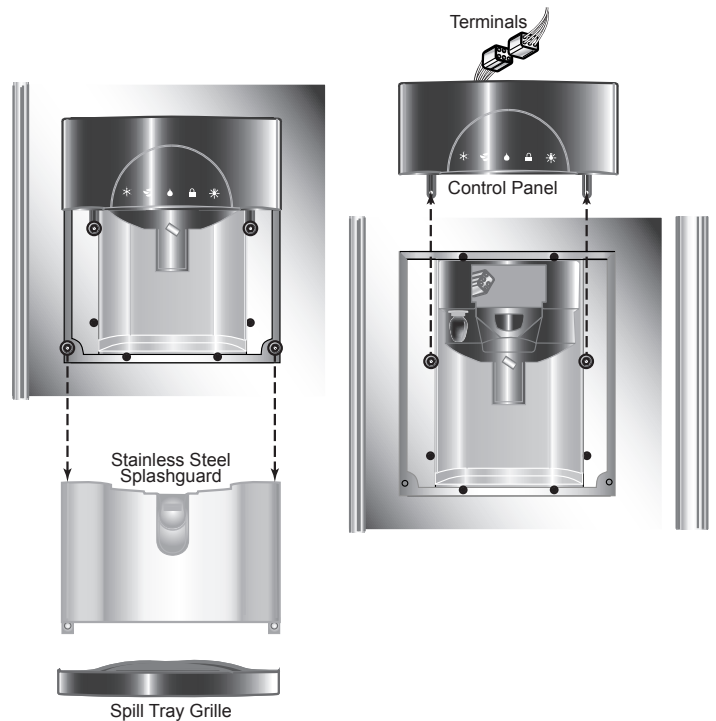
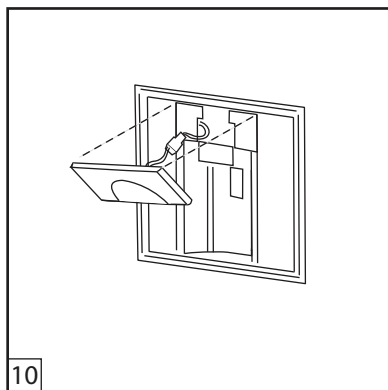

CAUTION

WARNING – Do not exceed the panel dimensions shown in the chart on page 4 for the grille panel. If the decorator panel is larger than specified, it may restrict the airflow to the compressor and condenser area, which may cause the unit to function improperly.

IMPORTANT: When attaching a raised wood panel of 1/2" or thicker secure the raised panel to the back of the grille cover frame. Use 4 #8 or similar screws.

Adjust Door Hinges

Check to make sure the doors are properly aligned. If not, the door hinges will have to be adjusted. Remove the two small shipping screws from the top and bottom hinge as shown below. Next, using a #25 torx screwdriver, loosen the torx head screws in the top and bottom hinge. Loosen the torx head screws only slightly, so that the door will remain in position as you adjust it. You will now be able to move the door to the left or right. Once the adjustments are made, tighten the torx head screws - do not put the shipping screws back.

INSTALLATION INSTRUCTIONS

Side Panel Installation

If using side panels with the Dacor® Built-In Refrigerator, they will need to be 1/4-inch thick. Slide the panel into position and secure with screws indicated by the shaded area. A 3/16-inch spacer is required between the cabinet and side panel. A 1/2-inch thick by 10 1/4-inch tall spacer is required if the side panel extends up into the machine compartment area on the refrigerator side.

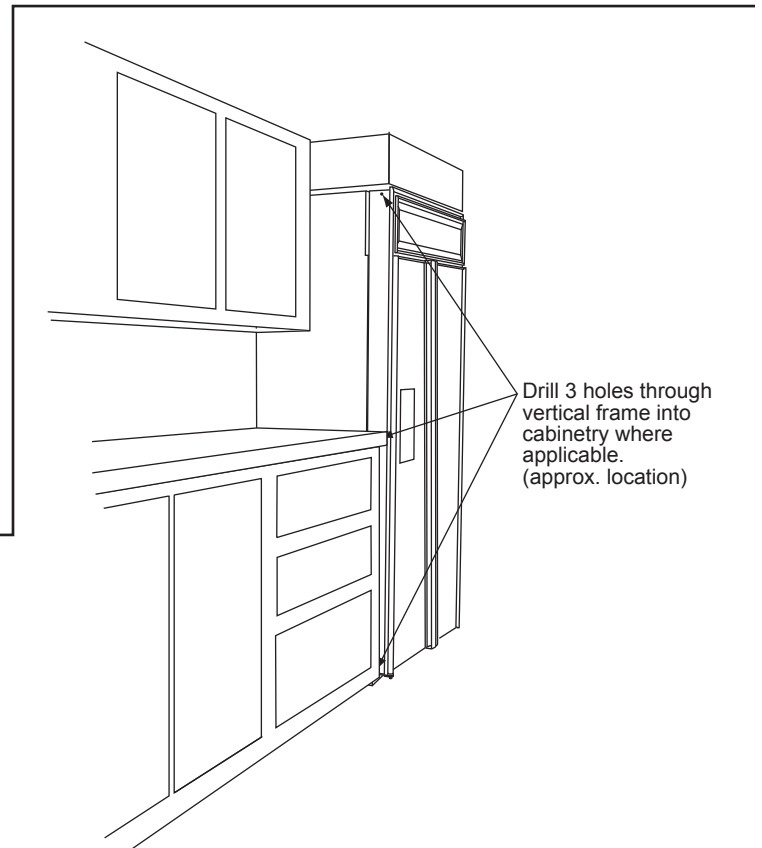
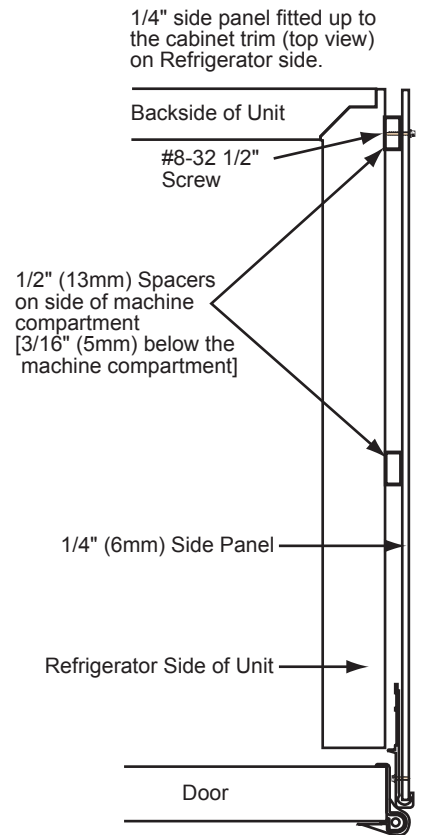
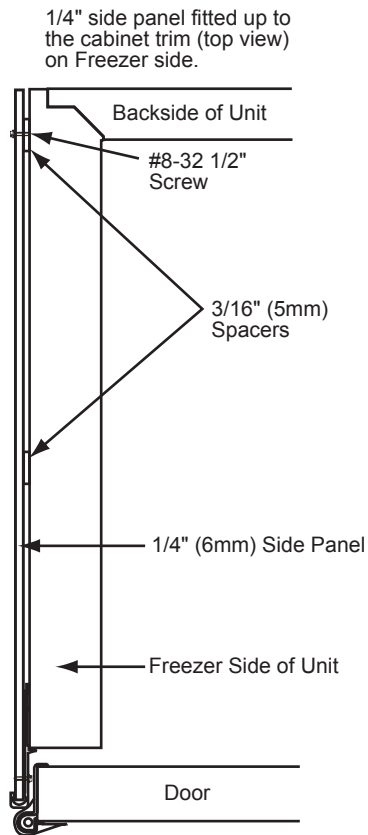
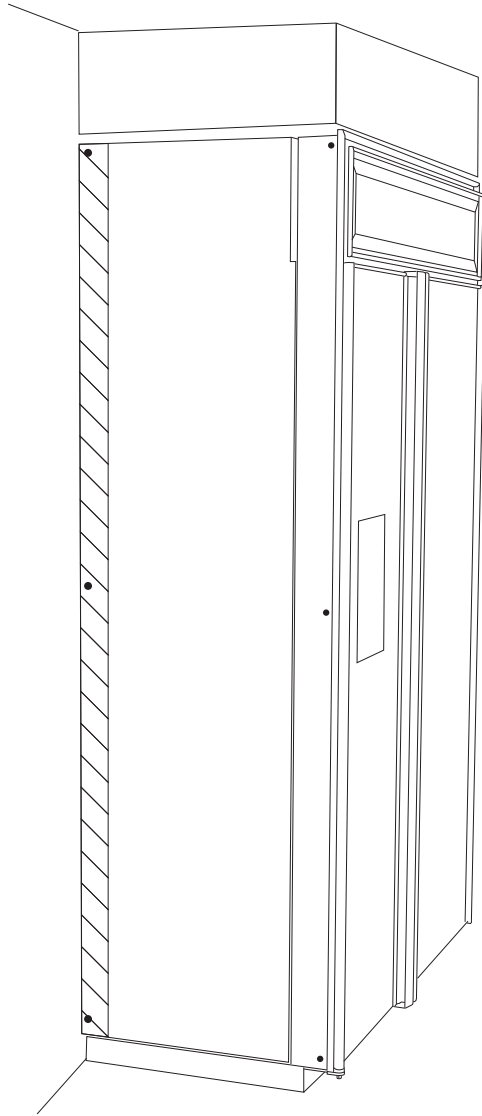

ANCHORING THE UNIT

After the door and side panels have been installed, and the unit has been leveled and door adjustment has been completed, you may anchor the unit to the opening.

- ◇ First, make sure the unit has been leveled and aligned, and the doors are adjusted.
- ◇ Drill three 3/16" holes through both outer trims.
- ◇ Drill a 1/8" pilot hole into the cabinetry.
- ◇ Install screws.

INSTALLATION INSTRUCTIONS

INSTALLATION CHECKLIST

The importance of the proper installation of your Dacor Built-In Refrigerator cannot be overemphasized. Proper installation is the responsibility of the homeowner.

IMPORTANT: To ensure a safe and proper installation, the following checklist should be completed by the installer to ensure that no part of the installation has been overlooked.

Any questions or problems with this installations should be directed to your Dacor® dealer or the Dacor® Customer Service Department at 800.793.0093 or email customerservice@dacorworld.com. You can also visit our website at dacor.com.

- Has the refrigerator been secured in place with the provided anti-tip blocking or is there a clearance of 1" (25mm) or less between the unit and a solid soffit?
- Are all leveling legs extended down to make contact with the floor? Is the unit level?
- Is the power cord plugged into a properly grounded dedicated 3-prong non-GFCI outlet, which had been installed in accordance with all applicable electrical codes?
- Is the water supply connected? Have you checked for leaks?
- Has the kickplate been installed properly?
- Are all panels attached securely and properly aligned?
- Have any installation/service problems been noted on the product registration card? Has the registration card been mailed?

SERVICE INFORMATION

If you need service, be sure to have the model and serial numbers when you call. You'll find these numbers on the serial number plate located on the light shield in the fresh food compartment.

Contact a Dacor® authorized Servicer, a Dacor® dealer, or the Dacor® Customer Service Department at 800.793.0093 or email customerservice@dacorworld.com

▼ DANGER

To reduce risk of injury or death, follow basic precautions, including the following:

IMPORTANT: Child entrapment and suffocation are not problems of the past. Junked or abandoned refrigerators are still dangerous – even if they sit out for “just a few days.” If you are getting rid of your old refrigerator, please follow the instructions below to help prevent accidents.

Before you throw away your old refrigerator or freezer:

- Take off the doors.
- Leave the shelves in place so children may not easily climb inside.

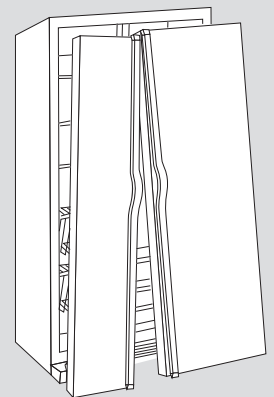

NOTES

NOTES

**Specifications contained within are subject to change without notice.
No liability is assumed by DACOR for changes in specifications.**

The information and images in this book are the copyright property of Distinctive Appliances, Inc. Neither this book nor any information or images contained herein may be copied or used in whole or in part without the express written permission of Distinctive Appliances, Inc.

Web Site:
Phone:

www.dacor.com
(800) 793-0093



©Distinctive Appliances, Inc. all rights reserved.

Free Manuals Download Website

<http://myh66.com>

<http://usermanuals.us>

<http://www.somanuals.com>

<http://www.4manuals.cc>

<http://www.manual-lib.com>

<http://www.404manual.com>

<http://www.luxmanual.com>

<http://aubethermostatmanual.com>

Golf course search by state

<http://golfingnear.com>

Email search by domain

<http://emailbydomain.com>

Auto manuals search

<http://auto.somanuals.com>

TV manuals search

<http://tv.somanuals.com>