

Datacard[®]

User's Guide for ImageCard[®] Select[™] and UltraGrafix[®] Select[™] Printers



August 2001

Part No. 539123-001

Please note and heed the WARNING and CAUTION labels that have been placed on the equipment for your safety. Please do not attempt to operate or repair this equipment without adequate training.

Liability statement

This Datacard® product has been built to the high standards of Datacard Corporation. See “Safety and compliance” on page A-1 for the statement of liability.

Regulatory compliance

This Datacard product conforms to regulatory requirements as specified in North America and Europe. See “Safety and compliance” on page A-1 for detailed regulatory compliance information.

Trademark acknowledgments

Trademark, service mark, and copyright acknowledgments are listed in “Safety and compliance” on page A-1.

Proprietary Notice

All drawings and information herein are the property of Datacard Corporation. Copyright © 2001 Datacard Corporation. All rights reserved.

Revision Log: User's Guide for ImageCard® Select™ and UltraGrafix® Select™ Printers

Revision	Date	Affected Pages	Description of Changes
A	Feb. 2001	All	Initial release
B	Aug. 2001	1-1, 1-3 to 1-5, 1-7, 1-11, 2-5 to 2-9, 2-11, 2-14, 3-2, 3-4 to 3-8, 3-10 to 3-12, 4-2, 4-8 to 4-15, 4-17, 4-37, 5-4, 5-12, 5-15, 6-4, 6-5, 7-2, 7-5 to 7-7, 7-11, 7-13, 7-14, A-1, A-2, B-2, B-7, B-9, B-12, B-13, C-6, E-2	Add information for directly networked printer, optional locking card cartridge, modified spring bar on swing arm, and updated driver installation.

Datacard
11111 Bren Road West
Minnetonka, MN 55343-9015
www.datacard.com
952.933.0333
Fax: 952.935.2314

© 1997-2001 Datacard Corporation. All rights reserved. Printed in the United States of America.



User's Guide for ImageCard® Select™ and UltraGrafix® Select™ Printers

Contents

Section 1: Operating the Printer

Chapter 1: Overview	1-1
About this manual	1-2
Audience	1-2
About the Select printer	1-2
About Advanced Imaging Technology	1-3
Printer models	1-3
Printer features	1-5
Who to call for assistance	1-9
Chapter 2: Using the printer	2-1
Loading cards	2-2
Loading the print ribbon	2-4
Powering on the system	2-6
Status light	2-7
Making cards	2-8
Operating tips	2-10
Removing cards	2-10
Responding to messages	2-11
Shutting down the system	2-13
Chapter 3: Using the printer driver	3-1
Working with printer settings and data	3-2
Tips for settings	3-2
Settings and data for Windows NT	3-2
Settings and data for Windows Me and 98	3-5
Settings and data for Windows 2000	3-6
Using the Status Monitor	3-9
Opening and using the Status Monitor	3-10
Viewing Status Monitor information	3-11
Chapter 4: Maintaining the printer	4-1
Running a cleaning cycle	4-2
Replacing the cleaning roller sleeve	4-2
Using the printer cleaning card	4-4
Using the magnetic stripe cleaning card	4-5
Cleaning the printer rollers	4-6
Cleaning tips	4-9
Cleaning the printhead	4-9
Replacing the printhead cartridge	4-10
Chapter 5: Troubleshooting	5-1
Troubleshooting guide	5-2
If you think the printer is not working	5-2
Making and evaluating test cards	5-3
Printer test card	5-4
Windows test page	5-5

Magnetic stripe test card	5-7
Problems with card appearance	5-7
Print Module	5-8
Topcoat applied using the print ribbon	5-13
Obtaining service	5-14
When to obtain service	5-15
Packing the printer for shipping	5-15

Section 2: Installing the Printer

Chapter 6: Before you install	6-1
Installation audience	6-2
General requirements	6-2
Selecting the site	6-3
Electrical requirements	6-3
Physical requirements	6-3
Environmental requirements	6-4
PC and software specifications	6-4
ID system installation sequence	6-5
Chapter 7: Install the printer	7-1
Unpacking the printer	7-2
Who to call for assistance	7-3
Connecting cables	7-3
Preparing the printer for driver installation	7-7
Installing the printer driver	7-7
Changing required printer settings	7-14
Printing sample cards	7-15
Setup tips	7-16
Optional settings	7-16

Section 3: Reference Information

Appendix A: Safety and compliance	A-1
Regulatory compliance	A-1
Notice for USA (FCC notice)	A-1
Notice for Canada	A-1
Notice for Europe	A-1
Notice to Users of Printers Equipped with Contactless Smart Card Coupler	A-1
Liability statement	A-2
Safety	A-2
Safe environment	A-2
Safe human interface	A-2
Acknowledgments	A-3
Appendix B: Supplies and cards	B-1
Personalization supplies	B-1
Print ribbons	B-1
Supply roll storage	B-2



Cards	B-3
Card specifications	B-3
Card size	B-3
Card material	B-3
StickCards	B-4
New cards preferred	B-4
Pre-punched cards	B-4
Card quality guidelines	B-5
Card storage specifications	B-6
Cleaning supplies	B-6
Printer cleaning card	B-6
Replaceable cleaning sleeve	B-6
Cleaning kits	B-7
Magnetic stripe cleaning card	B-7
Cleaning pen	B-7
Printer driver CD-ROM	B-8
Printer components	B-9
Printhead cartridge	B-9
Data cable	B-10
Power cord	B-11
Smart card serial cable	B-11
Print ribbon cartridge	B-12
Card cartridge	B-12
Replacement keys for optional Lock	B-12
Cleaning roller spindle	B-13
Related publications	B-13
Appendix C: PC settings	C-1
PC settings for all operating systems	C-2
Configuring the ECP parallel port	C-2
PC settings for Windows 2000 and NT 4.0	C-5
Setting parallel port values	C-6
Setting printer permissions	C-6
Setting a smart card serial port—Windows 2000 and NT	C-8
PC settings for Windows Me and 98	C-10
Setting parallel port values	C-10
Setting a smart card serial port—Windows Me and 98	C-11
Appendix D: Magnetic stripe encoding	D-1
IATA, ABA, and TTS character sets	D-1
NTT character set	D-2
Magnetic Stripe settings used by the Select printer	D-3
Magnetic Stripe Setup	D-3
Appendix E: Installation messages	E-1
Driver installation for Windows ME, 98, and NT	E-1
Driver installation for Windows 2000 only	E-10
Removing the printer driver for Windows ME, 98, & NT	E-11



User's Guide for ImageCard® Select™ and UltraGrafix® Select™ Printers

Overview

1

This chapter presents the following:

- The purpose of this manual
- Who should use this manual
- The Datacard® Select™ Class photo ID printer with Advanced Imaging Technology™, including a description of the printer, the models available, and their components

About this manual

This manual provides detailed information about the Datacard® Select™ Class photo ID printer with Advanced Imaging Technology™. The first section provides operators with information about the printer and how to use it. The second section provides installers with requirements for installation and installation procedures. The third section provides reference information.

This User Guide works with the online e-Guide, which you can see using the desktop icon installed with the printer driver. Figure 1-1 shows the e-Guide icon.



Figure 1-1: Desktop icon for the e-Guide

Audience

To operate the printer, you must have the following skills:

- Ability to read and understand written and graphical instructions
- Ability to operate a personal computer (PC)
- Experience with Microsoft® Windows® 98, Windows Me, Windows NT®, or Windows 2000
- Ability to load supplies
- Ability to perform simple troubleshooting using written and graphical instructions

For the skills needed for installation, see “Installation audience” on page 6-2.

About the Select printer

The Select photo ID printer includes the printer and a printer driver which runs on a PC. The printer uses supplies when printing cards, including:

- New Advanced Imaging Technology print ribbon
- New replaceable cleaning sleeves
- Blank cards

The Select printer prints full-color or monochrome images on one or both sides of PVC cards. The images printed can include photos, text, logos, barcodes and digitized signatures. The printer can also encode data on a card's magnetic stripe and program a smart card chip on a card. (These steps are commonly called “personalizing” the card.) Magnetic stripe encoding and smart card programming are options that can be purchased as part of the printer.

The printer driver receives digital information from a card creation application and processes the data to send to the printer. When the printer receives the data, it prints



the card. The driver keeps track of the progress of the card in the printer and sends data for the next card as soon as the printer is ready and the data is available.

See “PC and software specifications” on page 6-4 for more information about the printer driver and the PC on which it runs.

About Advanced Imaging Technology

With Advanced Imaging Technology, processing and printing are enhanced for the highest quality images. Three features of the printer work together to provide the benefits of Advanced Imaging Technology:

Print ribbon: New Premium Print Ribbon for use with Advanced Imaging Technology™ must be used in the Select Class printer with Advanced Imaging Technology™.

Printer unit: The printer has been enhanced to provide optimal color printing.

Printer Driver: The printer driver includes new color settings. “Using the Status Monitor” on page 3-9 provides more information about color settings.

Printer models

Several models of the printer are available. ImageCard printers can print full-color or monochrome images, while UltraGrafix printers can print only monochrome images. The printer label provides information about the options in your printer (see Figure 1-2). The label also includes the printer serial number.

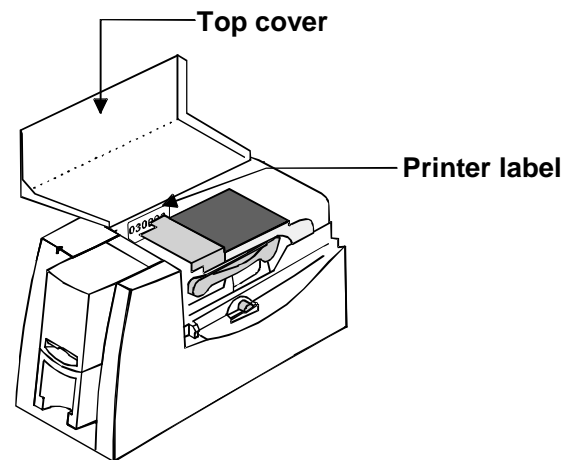

Figure 1-2: Printer label

A printer can be ordered with the following optional modules:

- Duplex module. The duplex module extends the length of the printer and flips the card to automatically print on both sides of the card. The model name includes the number “2” if the printer has a duplex module.

- Magnetic stripe module, for either 3-track (IAT) encoding or single-track NTT encoding. The module is installed in-line with the print operation. It encodes data on the magnetic stripe and then verifies the data.
 - Smart card module. The smart card module has the following available options:
 - Contact coupler (SC 410)
 - Contactless (RF) coupler (“SC 680” on the printer label)
 - Both contact and contactless couplers (“SC Comb” on the printer label)
 - Contact station (“SCCS” on the printer label) with external coupler.
- i** A custom smart card application can use the module to initialize and program the smart card chip on a card.

Table 1-1 lists the models and their features.

Table 1-1: Select printer features available

Model name	Colors printed	Duplex module	Magnetic stripe [#]	Smart Card [#]
ImageCard Select	Full color or monochrome	No	Yes [#]	Yes [#]
ImageCard Select 2	Full color or monochrome	Yes	Yes [#]	Yes [#]
UltraGrafix Select	Monochrome only	No	Yes [#]	Yes [#]
UltraGrafix Select 2	Monochrome only	Yes	Yes [#]	Yes [#]

#. Optional



Printer features

Use the information in this section to identify the features and controls you use on the printer.

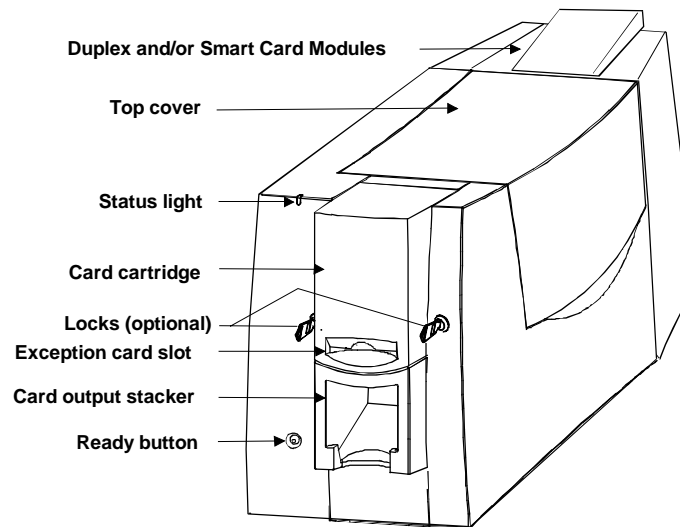

Figure 1-3: Front of the Select printer

Outside of the printer

Find the following on the outside of the printer:

Duplex module

The optional duplex module flips the card to automatically print on both sides of the card. If the printer includes an optional smart card module, it is located inside the duplex module or in a duplex housing.

Top cover

The cover protects the internal parts of the printer from dust and debris. It also lessens the sound from the printer.

Status light

The status light indicates that the printer power is on, is processing data, is ready to receive data, or is in an error condition.

Card cartridge

The card cartridge holds blank cards to print. It holds about 100 cards (with a nominal thickness of 0.030 inches (0.76 mm)). At the bottom of the card cartridge, the **exception card slot** allows you to insert a single card that is different from the cards in the card cartridge.

Card output stacker

The card output stacker holds the cards after they have been processed. Both completed cards and rejected cards go to the card output stacker.

Ready button

The Ready button allows you to pause the printer while printing a card, to clear an error condition, to cancel a print job and delete all data for the job, or to create a printer test card.

Lock (optional)

The optional lock allows you to lock the card cartridge into position, preventing cards from being removed without authorization. Some printers have two locks to meet the security requirements of the organization.

Inside the printer

Open the cover to find the following on the inside of the printer.

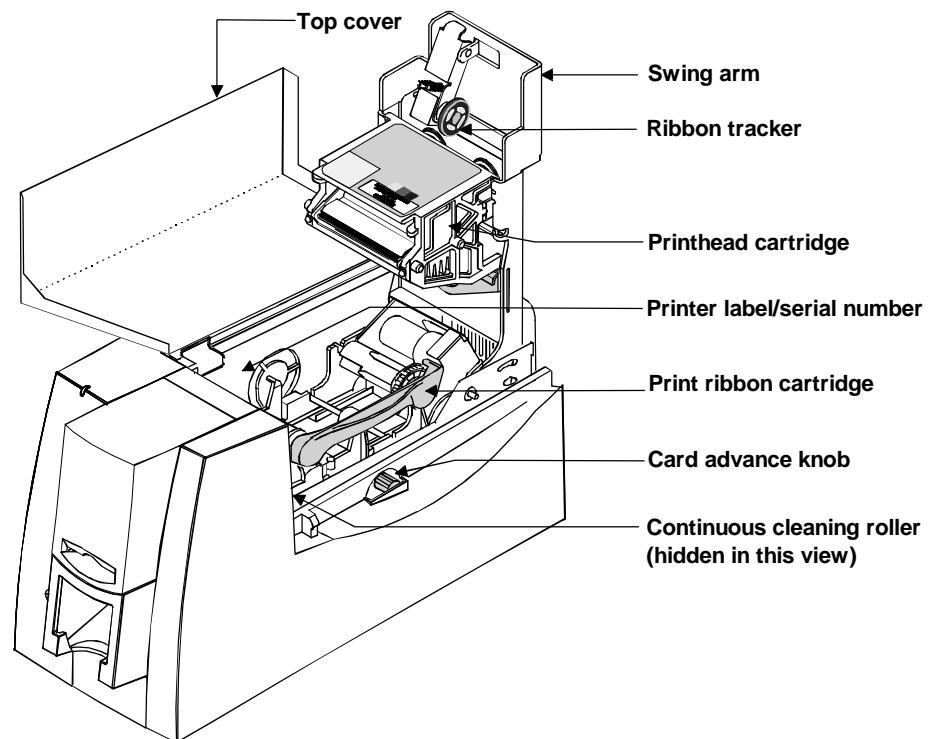

Figure 1-4: Internal parts of the Select printer



User's Guide for ImageCard® Select™ and UltraGrafix® Select™ Printers

Swing arm

The swing arm opens to give you access to the print ribbon cartridge, continuous cleaning roller, and printhead cartridge. Push down on the raised end of the swing arm to open it.

Ribbon tracker

The ribbon tracker measures the movement of the print ribbon as it moves from the supply spool during printing.

Printhead cartridge

The printhead, contained in the printhead cartridge, applies heat and pressure, which transfers dye and other material from the print ribbon to the card. The printhead cartridge is replaceable.

Printer label/serial number

The printer label includes the printer serial number and information about optional components of the printer.

Print ribbon cartridge

The print ribbon cartridge holds the print ribbon.

Card advance knob

The card advance knob turns to move a card along the card transport track. If a card remains in the printer, use this knob to move the card in the card track.

Continuous cleaning roller

The continuous cleaning roller is a new feature of the Select printer with Advanced Imaging Technology. The roller includes a spindle and a replaceable cleaning sleeve. The spindle holds the roller in place. The replaceable cleaning sleeve removes dirt and debris from the permanent cleaning roller in the printer and should be changed regularly.

Back of the printer

Figure 1-5 shows the back of the Select Class printer:

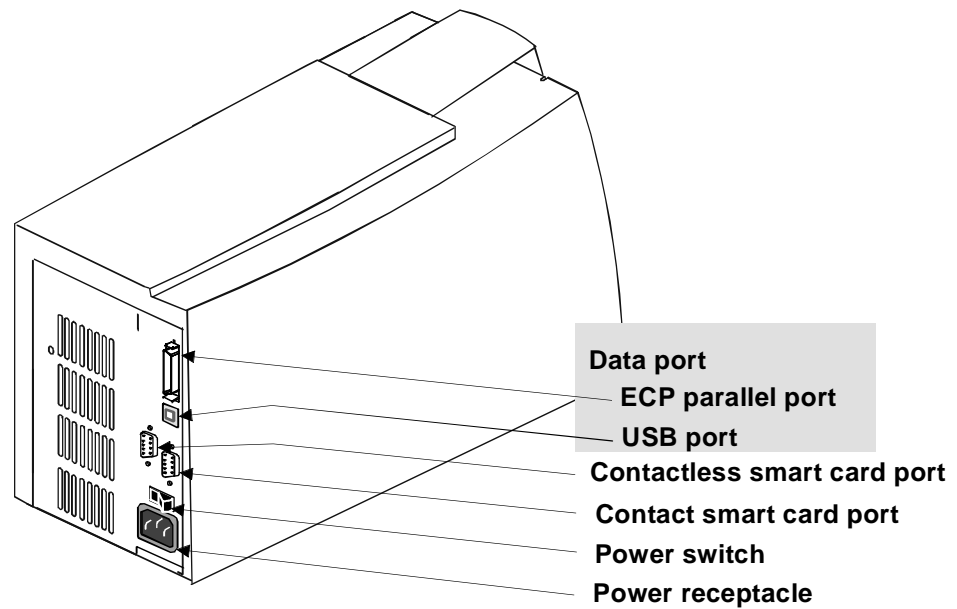

Figure 1-5: The back of the Select printer

If the printer includes an optional simplex smart card module or duplex module, that module extends farther than the ports and receptacles.

Find the following on the back of the printer:

Data Port

The printer includes two data ports. Select only one data port to use.

- ECP parallel port
Use the ECP parallel port to connect the printer's data cable to the PC, if the printer was ordered with a parallel cable.
- USB port
Use the USB port to connect the printer's data cable to the PC, if the printer was ordered with a USB cable.

Power switch

Use the Power switch to power on or power off the printer.

Power receptacle

This is the receptacle for connecting the power cable.



Smart card serial port(s)

On printers equipped with the smart card option, use these connectors for the serial cable from the PC or contact station that carries the data to encode on the smart card chip. If the printer does not have any smart card options, the ports will not be installed in the printer.

Who to call for assistance

If you work with a Datacard-authorized distributor or value-added reseller, contact them for assistance. A value-added reseller provides the Select printer as part of an overall system.

If any contents of the box are missing, contact your distributor or reseller. If you purchased your printer directly from Datacard, contact Datacard. Make sure you have the serial number when you call (see Figure 1-2).



User's Guide for ImageCard® Select™ and UltraGrafix® Select™ Printers

Using the printer

2

This section describes how to perform basic tasks required to operate the Datacard® Select™ Class photo ID printer with Advanced Imaging Technology™. It describes:

- Loading cards
- Loading print ribbon
- Powering on the printer
- Making cards
- Removing cards
- Responding to messages
- Powering off the printer

Begin with the printer set up and the printer driver installed. If the printer is not set up, see “Before you install” on page 6-1 and “Install the printer” on page 7-1 to set up the printer and install the driver.

Loading cards

Load cards when beginning work or when the card cartridge is low on cards or empty. You can load cards when the printer power is on or off. You can also load cards while the printer is printing. To order more cards, contact your card vendor. For information on card requirements, see "Supplies and cards" on page B-1.

Load cards

- 1** If the printer has a locking card cartridge, unlock the cartridge before removing it.
- 1 Pull up on the lower edge of the card cartridge (see step 1 in Figure 2-1). Lift the card cartridge up and out of the printer (step 2 in Figure 2-1).

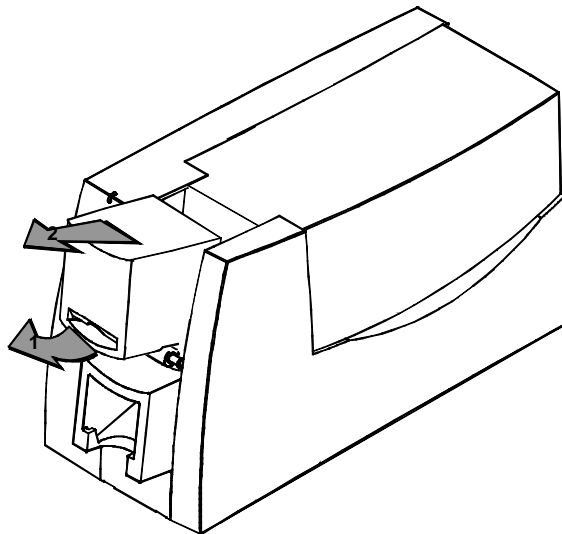

Figure 2-1: Remove the card cartridge

- 1** Do not touch the surface of cards before printing them. Handle cards by the edges or wear gloves to protect cards. Oils on hands can cause discolored printing.
- 2 Fan cards to separate the edges of the cards (see Figure 2-2).



Figure 2-2: Fan cards

- 3 Place up to 100 blank cards into the card cartridge. (If the cards are thicker or thinner than 0.030 inch (0.76 mm), the maximum number of cards you can load varies.)

For magnetic stripe cards, the magnetic stripe faces down and is positioned toward the side of the printer that opens (see Figure 2-3). (For some custom applications, you might receive instructions to place cards in a different orientation.)

For smart cards, position the card so the chip is up and toward open end of the card cartridge.

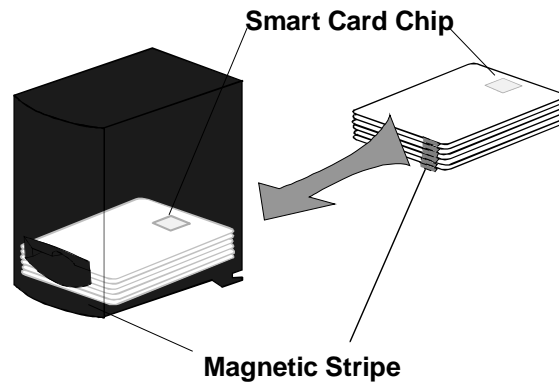

Figure 2-3: Load cards into the card cartridge

- 4 Replace the card cartridge in the cavity (step 1 in Figure 2-4). Push the bottom of the card cartridge toward the printer until it clicks into place (step 2 in Figure 2-4).

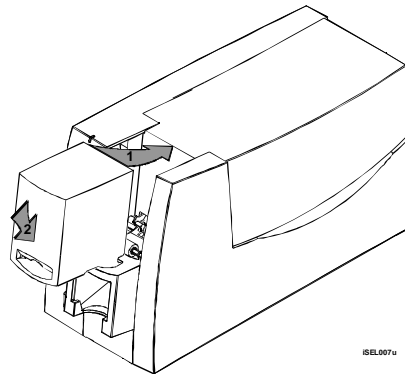

Figure 2-4: Replace the card cartridge

- i** If the printer has a locking card cartridge, lock the cartridge after replacing it.



Loading the print ribbon

The printer uses print ribbon with color panels, continuous color, or color and topcoat. Full-color ribbon (such as YMCKT) must be Premium ribbon, which uses blue ribbon spools. Monochrome (one color) ribbon on teal ribbon cores can also be used. (Full-color ribbon on teal cores cannot be used.)

i The type of print ribbon you use must match the print ribbon setting in the driver.

To order new ribbon, contact your service provider. See “Supplies and cards” on page B-1 for information about ribbons available.

Remove the print ribbon cartridge

- 1 Lift the top cover, as shown in Figure 2-5.

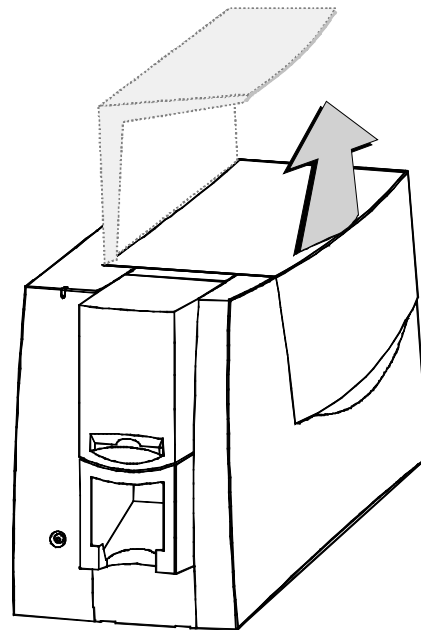

Figure 2-5: Open the cover

- 2 Press down on the swing arm until it clicks (step 1 in Figure 2-6). The push latch releases the swing arm. Lift the swing arm until it is fully open (step 2 in Figure 2-6).

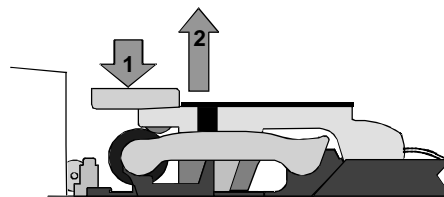

Figure 2-6: Open the swing arm



- 3 Grasp the ribbon cartridge handle, and lift up to remove the print ribbon cartridge (see Figure 2-7). Avoid touching the printhead cartridge and ribbon tracker.

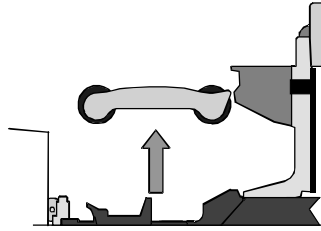

Figure 2-7: Remove the print ribbon cartridge

- ◆
- i** Some users run a cleaning cycle whenever the print ribbon is changed. If your site follows this policy, see “Running a cleaning cycle” on page 4-2 for the steps to follow, and then return to this section.

Load the print ribbon

- 1 Remove the used ribbon and the used ribbon spools from the ribbon cartridge shafts.
- i** The print ribbon has a negative image of the information printed on the card. Dispose of print ribbon according to your policy for protecting the data that might be visible on it.
- 2 Unwrap the new print ribbon.
- 3 Slide the full supply roll onto the left ribbon cartridge shaft (see Figure 2-8).
- 4 Slide the empty take-up ribbon spool onto the right ribbon cartridge shaft (which has a gear). Leave very little slack in the ribbon between the ribbon cartridge spools (see Figure 2-8).

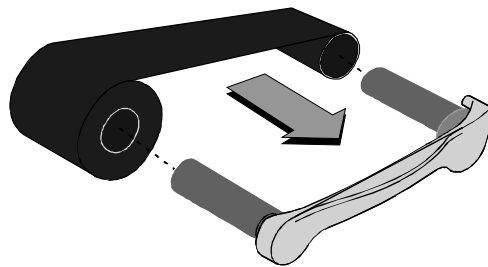

Figure 2-8: Load new print ribbon on the ribbon cartridge

- 5 Make sure print ribbon unwinds over the top of the print ribbon cartridge, not from the bottom.



Replace the print ribbon cartridge

- 1 Place the ribbon cartridge onto the ribbon cartridge supports (see Figure 2-9). Make sure the cartridge is securely seated. Avoid touching the printhead cartridge and ribbon tracker.

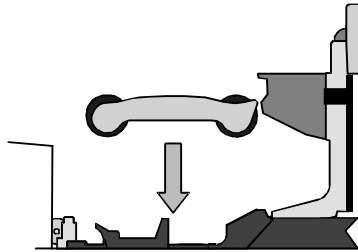

Figure 2-9: Replace the print ribbon cartridge

- 2 Close the swing arm, pressing it down until the push latch clicks into place.
- 3 Close the cover.



Powering on the system

Use the following procedure to power on the printer and attached PC.

Power on the printer

- i** If the printer is connected over a network using a print server, see the *SmartDriver Direct Network Installation and User Guide* for more information about powering on the printer.
- 1 Make sure cards and all other supplies are loaded. See other sections of this chapter for more information.
- 2 Remove any printed or rejected cards from the output stacker.
- 3 Make sure the power cord and data cable are connected. If needed, see "Connecting cables" on page 7-3 for more information.
- 4 Press the printer Power switch to turn on power. Observe the printer status light which lights with a sequence of colors and then becomes steady green. See "Status light" on page 2-7 for more information. The printer initializes components and makes audible sounds.

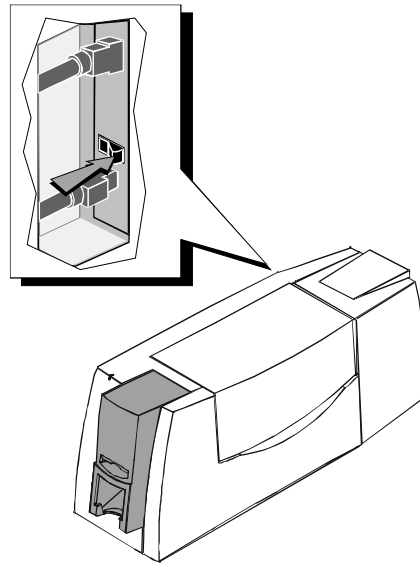

Figure 2-10: Power on the printer

- 5 Press the PC Power switch to turn on the power to the PC. Turn on power to any other equipment needed.



Status light

The front of the printer has a light that provides information about the printer's current state.

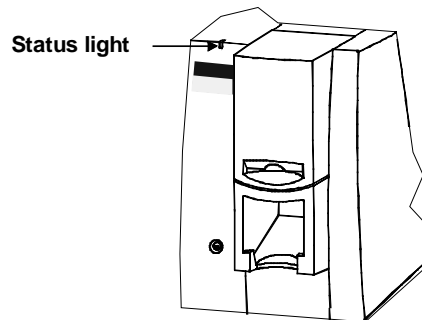









Figure 2-11: Status light

Status Light	Description
 Red Amber Green	The printer is starting. The printer displays colors repeatedly while it initializes.

Status Light	Description
 Steady green	The printer is ready and waiting to print cards.
 Blinking green	The printer is busy printing cards.
 Steady amber	The printer is paused without an error.
 Blinking amber	The printer has issued a message. See the PC for the message. [#]
 Steady red	The printer has a problem that requires service.
 Off	The printer power is off.

#. If the light blinks amber but no message appears on the PC, the following might have occurred:

- * You used the Power-on/Ready sequence to print a test card. Messages are not reported.
- * You changed the name of the printer. Remove and re-install the printer driver to change the printer name.

Making cards

This section describes several ways to make cards using the Select printer.

- Usually, cards are sent from a card creation application, such as Datacard's ID Works™ which captures, organizes, and formats the information on the card. A card creation application is specially designed software that handles the types of information used on cards. See "Use a card creation application" for the steps to follow.
- If you do not have a card creation application, you can use another PC application to format the information to print on cards. If you are encoding magnetic stripe data, be sure to use an application in which you can save the result and edit it again, such as Windows WordPad™ or Word. See "Print from a PC application" for the steps to follow.

i With any application, test your card design to verify the results.

Use a card creation application

- 1 Follow the instructions for the card creation application to capture, format, and save the data for the card.



- 2 In the card creation application, send cards to the printer.

The printer driver receives data for each card, prepares the card for printing, and sends each card to the printer in the order received. The printer driver keeps cards in a queue if the printer is busy.

- i** Developers can write card creation applications using the SmartDriver™ Software Developer's Kit. This kit can be downloaded from www.datacard.com.



Print from a PC application

- 1 Select the printer settings that correspond to the cards to print. See "Working with printer settings and data" on page 3-2 for more information. Settings might include the following:
 - Enable two-sided printing if you plan to print the front and back of the card.
 - Set the margins for the area to print on the card. A setting of Edge-to-Edge is the same as a margin of 0.
 - Set the magnetic stripe format and coercivity if you plan to encode magnetic stripe data.
 - 2 In the application, select the Select printer as the current printer.
 - 3 Using the application's page setup feature, set the paper size to CR80 Card 2.13" x 3.38." Set all the margins to the same value as the driver. (You can set the margins in the application wider than the driver, if desired.)
 - 4 Select the orientation for the card design—either portrait or landscape.
 - 5 Format the text to print using only a TrueType () font. To print using the true black (K) panel of the print ribbon, use the Black color selection. All other colors are printed using the color panels of the print ribbon if you use a color print ribbon.
 - 6 To print on the front of the card, keep data on one page. To print the front and back of the card, send a two-page document. (Make sure Print on Both Sides is set to Automatic or Manual.)
 - 7 Also on the front of the card, enter the information to be encoded on the magnetic stripe and format the text using one of the following fonts:
 - Track 1—Magnetic Stripe
 - Track 2—Magnetic Stripe
 - Track 3—Magnetic Stripe
 - Track NTT—Magnetic Stripe (use only on a PC running a Japanese language Windows operating system)
- i** Windows must be set to display all fonts. (Some PC's are set to display TrueType fonts only.) See Windows help for more information.



The text for one magnetic stripe track must be on one line. The text must use the default type size of 3.5 or 4 points to keep characters on the same line. To view the characters, zoom in on the text. Also, follow these guidelines:

- Do not use typographic features, such as letter spacing, on magnetic stripe text.
 - The paragraph style must be Normal.
 - The magnetic stripe text, along with graphics and text to print on the front of the card, must be on the first page.
- 8 When the card data is captured and formatted correctly, select the application's print function to send the card to print.



Operating tips

- For the most current information about messages, see the online help for each message.
- Whenever you are encoding magnetic stripe data or programming smart cards, be sure to handle incomplete cards according to your policy for handling the confidential data that might be on the card.
- Used print ribbon contains negative images of data printed on cards. Be sure to handle used print ribbon according to your policy for handling the confidential data that might be on the card.

Removing cards

The card output stacker holds both completed cards and rejected cards. Remove completed cards from the output stacker to distribute printed cards. The card output stacker holds about 20 cards.

Remove rejected cards as soon as they are ejected from the printer so you do not need to sort through all cards to locate them. Cards are rejected when a print job is cancelled or when a problem occurs with personalizing a card.

You can remove cards when the printer power is on or off, or while the printer is printing. Completed and rejected cards are removed in the same way.

Remove cards

- 1 Lift the cards from the card output stacker.



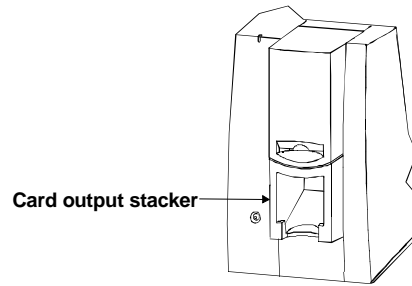

Figure 2-12: Remove cards

- 2 Dispose of partly processed cards according to your policies for handling the confidential data that might be on the cards.



Responding to messages

The Select printer provides information to the printer driver about the status of cards being processed. If the printer is not able to process and print a card, the printer driver generates a message on the PC in response to this situation. In most cases, the message is displayed on the PC. Some applications manage printer driver messages, and those messages might be different than described in this section.

In some circumstances, the printer might beep and the status light blink amber without a message appearing on the PC. The most likely causes are:

- Renaming the printer on Windows 2000 (Restart Windows to fix the problem)
- Printing a test card in a printer with a magnetic stripe module, when the card does not have a magnetic stripe (use a card with a magnetic stripe and make sure the stripe is oriented correctly)

Messages can be generated from another networked PC. For example, a different ribbon type can be selected on another networked PC. Change the Ribbon Type setting to match on both PCs.

Messages include a Help button, where information about recovering from the situation is available. Typical messages might indicate that the print ribbon needs to be replaced or that a card is stuck. See the “Fix a printer problem” procedure that follows.

- i** When a message box appears, only use the buttons on the message box, so that both the printer driver and printer can return to normal operation.



Figure 2-13: Typical message

If a message appears repeatedly and you cannot reliably correct the situation, service might be required.

i Before you call your service representative, write down the following:

- The message and message number.
- The model of the printer, such as “ImageCard Select 2 with Advanced Imaging Technology.”
- The serial number of the Select printer located on a label visible when the top cover is open. See “Printer label” on page 1-3.
- The driver version, described in “Working with printer settings and data” on page 3-2.
- The firmware version (available on Windows Me and Windows 98).

For more information about obtaining service, see “Obtaining service” on page 5-14.

Fix a printer problem

- 1 When a message is displayed on the PC, follow the suggested action. Click the Help button (if present) to identify the likely cause of the problem and the possible solution.
- 2 From the help topic, click the “Open the e-Guide” link to view a list of procedures. Select the procedure indicated in message help, and follow the procedure provided in the e-Guide to fix the problem.

Most parts of the printer designed to be used by the operator are colored green. These parts include knobs for clearing jams and handles of supply cartridges.

- 3 After fixing the problem, close the cover of the printer.

i If the printer has a locking card cartridge, lock the cartridge.

- 4 Depending on the situation, the message box might be removed automatically or you might need to respond. Cards still in the printer might be ejected.

The message box can have one or more of these buttons:

- **Retry**: Clears the card from the printer. The driver sends the card or cards to the printer again. If the problem is corrected, normal operation resumes.
- **Cancel**: Clears the card from the printer. The card is not sent to print again. If the problem is corrected, normal operation resumes.
- **OK**: Used for a message that occurs when no card was being printed or an equipment failure. If the problem is corrected, normal operation resumes. (Power cycle the printer if operation does not resume.)
- If the message box disappears automatically, decide whether to return to the card creation application to send the card to print again.



Shutting down the system

The printer and PC can be left on during lunch time and other short breaks. Follow your security procedures when leaving the printer.

Shut down the printer and system

- 1 Make sure all cards have completed processing before turning off the power. (You can suspend the Status Monitor to stop communication between the printer and driver. See "Using the Status Monitor" on page 3-9.)
- 2 Press the Power button to turn off power to the printer.

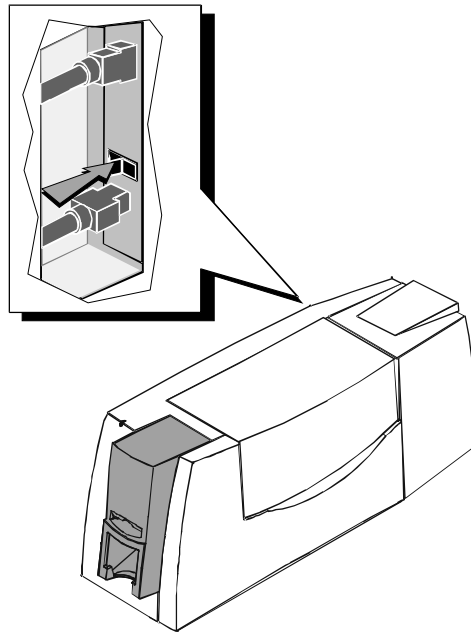

Figure 2-14: Press the power button to power off the printer

- 3 Follow your policy to secure unprinted card stock, supplies, and printed cards. For example:
 - Remove the card cartridge.
 - Remove the print ribbon cartridge. Carry cartridges to a secure location, such as a safe, a locking drawer, or a locking closet.
 - 4 Close PC applications and power off other equipment (including the PC) following the procedure established.
- i** If you will store the printer for several months, remove supplies before storing (including cards, print ribbon, and replaceable cleaning sleeve).





User's Guide for ImageCard® Select™ and UltraGrafix® Select™ Printers

Using the printer driver

3

This chapter provides information to help you use the printer driver for the Select printer with Advanced Imaging Technology™ effectively and efficiently. It describes:

- How to work with printer settings and data
- How to use the Status Monitor

Working with printer settings and data

Printer driver settings and data are organized differently for Windows NT, Windows Me and 98, and Windows 2000. Use the section that applies to the operating system you use.

Tips for settings

When you use settings, consider the following for greatest success:

- At installation, the Select printer driver uses default settings for the printer. At setup, you need to view, change, and save printer and driver settings. As you use the printer, you might change the card design and need to change settings to reflect that, or you might need to view settings or data about the printer..
- For settings that affect the printer, such as print ribbon type, make sure that the printer and PC are connected so the value you select is sent to the printer and saved. (For printers shared over a network, see *e-Guide for ImageCard® Select™ and UltraGrafix® Select™ Printers*. For printers connected over a network using a print server, see the *SmartDriver Direct Network Installation and User Guide*.)
- For settings that affect only the card format, such as landscape or portrait orientation, the printer does not need to be connected and powered on.
- The card creation application might include settings that override driver settings. Also, you can access printer settings through the application's print feature. (Depending on the application, settings will apply only to the current document or session.)
- When the printer is installed, the default spool setting is "Spool printing so program finishes printing faster." Use this setting, not "Print directly to printer." The default setting is required to print multiple copies of the same card.
- When the printer is installed, "Enable bi-directional support" is selected. This setting is required to display messages, print test cards, and for other functions.
- When the printer is directly networked to a PC, the Color Settings page of Advanced Setup can be used from all PCs. The Printhead page of Advanced Setup should be used only from the administrative PC.
- When the printer is networked to more than one PC, the same ribbon type should be selected on all networked PCs.

Settings and data for Windows NT

Settings that control the printing and personalization of the card are in the Default Document Properties dialog box for the printer. These settings include:

- Print on both sides (duplex printing)
- Print ribbon type
- Card design settings, such as landscape or portrait orientation



- Topcoat pattern during the print cycle
- Cleaning interval
- Magnetic stripe encoding formats and coercivity

The Default Document Properties dialog box also provides access to the About dialog box, which shows the printer driver version.

Settings that control the non-printing operation of the printer are in the Properties dialog box for the printer. These settings include:

- Port to which the printer is attached
- Permissions for other users of the PC

i The Select printer driver provides help for the Default Document Properties dialog box and Windows NT provides help for the Properties dialog box. Help provides information about specific settings of the Select printer driver. Help does not include step-by-step procedures or detailed conceptual information.

Use the Properties dialog box

Make sure the printer power is on and the printer is connected to the PC.

- 1 Select Start from the Windows NT taskbar.
- 2 From the Windows NT Start menu, select Settings and then Printers. The Printers window appears.
- 3 Click once on the Select printer driver icon.
- 4 Select File from the Printers menu bar, and then select Properties. The Select Properties dialog box appears.

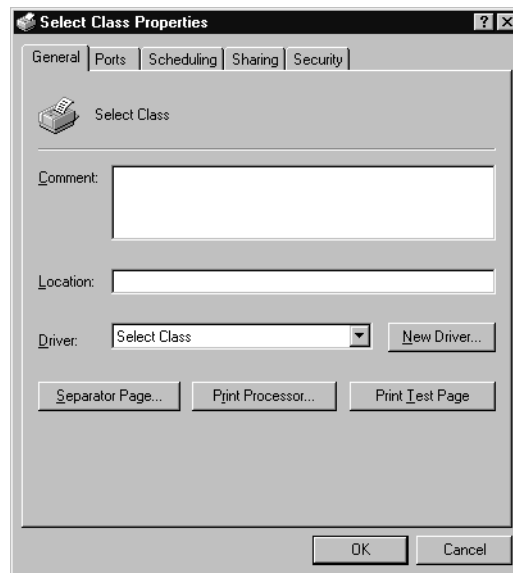

Figure 3-1: Properties dialog box, Windows NT

- 5 Select the tab that contains the information you want to view or change.
- 6 If you make changes, click OK to save the settings and close the dialog box. If you do not want to make changes, click Cancel to close the Properties dialog box.
- 7 If you change the port, restart Windows and power cycle the printer.



Use the Default Document Properties dialog box

Make sure the printer power is on and the printer is connected to the PC.

- 1 Select Start from the Windows NT taskbar.
- 2 From the Windows NT Start menu, select Settings and then Printers. The Printers window appears.
- 3 Click once on the Select printer driver icon.
- 4 Select File from the Printers menu bar, and then select Document Defaults. The Select Default Document Properties dialog box appears.

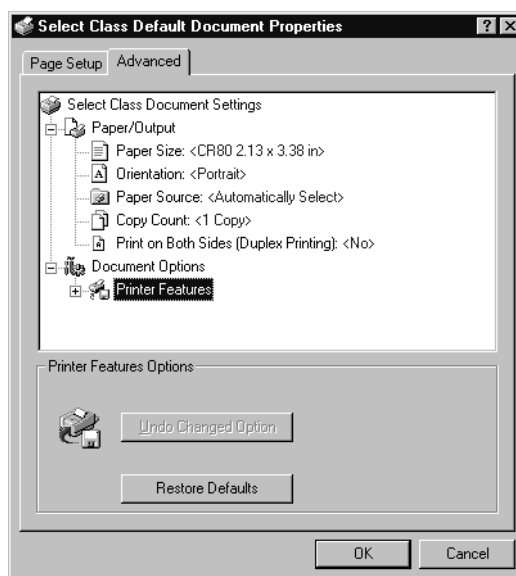



Figure 3-2: Default Document Properties dialog box for Windows NT

- 5 Select the tab that contains the information you want to view or change. On the Advanced tab, click the plus sign (+) if needed to see all selections available. When you click a selection, choices appear in the “Change. . .” box. Click the value you want.
- i** Select the Print on Both Sides setting before selecting the Print Ribbon Type and Topcoat Pattern. The choices available for Print Ribbon Type and Topcoat Pattern depend on the Print on Both Sides setting. If you change the “Print on both sides”

setting after selecting YMCKTKT ribbon, the Print Ribbon Type value will be blank.

- i** If the selections you want to use are not available (are grayed out), make sure the feature is available in the printer. Also make sure that the printer is powered on and connected to the PC and resume the Status Monitor. See “Opening and using the Status Monitor” on page 3-10.
 - i** To view help for settings, click on the What's This help button  and then click any setting in the Printer Features list. A list of settings is displayed. Select the setting for which you want help.
- 6 If you make changes, or if this is the first time you have viewed the Document Default Properties dialog box, click OK to save the settings and close the dialog box.



Settings and data for Windows Me and 98

Settings that control the printing and personalization of the card include:

- Print on both sides (duplex printing)
- Card design settings, such as landscape or portrait orientation
- Topcoat pattern during the print cycle
- Cleaning interval
- Magnetic stripe encoding formats and coercivity

Data about the printer is available, including the “About” dialog box which shows the printer driver version.

Use the Properties dialog box

Make sure the printer power is on and the printer is connected to the PC.

- 1 Select Start from the Windows taskbar.
- 2 From the Windows Start menu, select Settings and then Printers. The Printers window appears.
- 3 Click once on the Select printer driver icon.

- 4 Select File from the Printers menu bar, and then select Properties. The Select Properties dialog box appears.

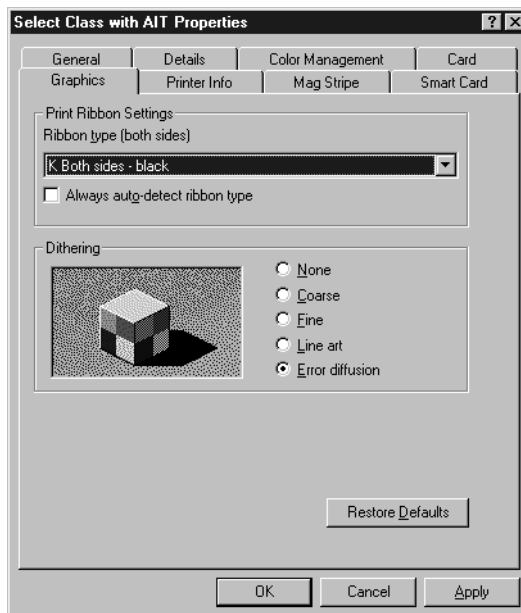



Figure 3-3: Properties dialog box, Windows Me and 98

- 5 Select the tab with the information to view or change.
 - i** Select the Print on Both Sides setting before selecting the Print Ribbon Type and Topcoat Pattern. The choices available for Print Ribbon Type and Topcoat Pattern depend on the Print on Both Sides setting. If you change the Print on Both Sides setting after selecting YMCKTKT ribbon, the Print Ribbon Type value will be blank.
 - i** To view help for settings, click on the What's This help button .
- 6 If you make changes or if you have just installed the printer driver, click Apply to save the settings. Click OK to close the dialog box. If you do not want to make changes and have saved settings once, click Cancel to close the Properties dialog box.



Settings and data for Windows 2000

Settings that control the printing and personalization of the card are in the Printing Preferences dialog box for the printer. These settings include:

- Card design settings, such as landscape or portrait orientation
- Topcoat pattern during the print cycle
- Cleaning interval



User's Guide for ImageCard® Select™ and UltraGrafix® Select™ Printers

- Magnetic stripe encoding formats and coercivity

The Printing Preferences dialog box also provides access to the About dialog box, which shows the printer driver version.

Settings that control the non-printing operation of the printer are in the Properties dialog box for the printer. These settings include:

- Port to which the printer is attached
- Permissions for other users of the PC

i The Select printer driver provides help for the Printing Preferences dialog box and Windows 2000 provides help for the Properties dialog box. Help provides information about specific settings of the Select printer driver. Help does not include step-by-step procedures or detailed conceptual information.

Use the Properties dialog box

Make sure the printer power is on and the printer is connected to the PC.

- 1 Select Start from the Windows 2000 taskbar.
- 2 From the Windows Start menu, select Settings and then Printers. The Printers window appears.
- 3 Click once on the Select printer driver icon.
- 4 Select File from the Printers menu bar, and then select Properties. The Select Properties dialog box appears.

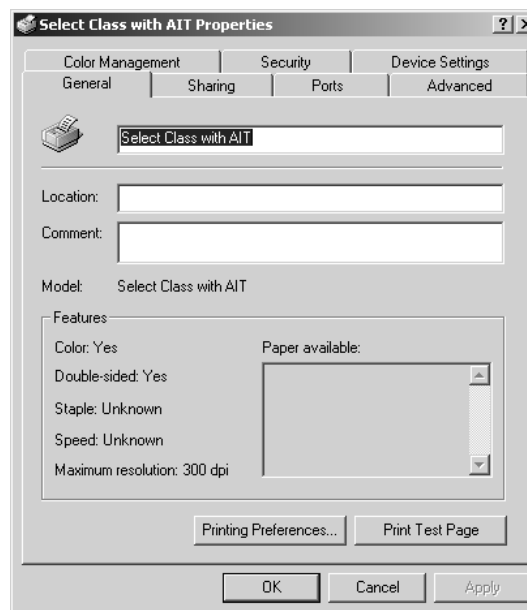

Figure 3-4: Select Properties dialog box, Windows 2000

- 5 Select the tab that contains the information you want to view or change.

- 6 If you make changes, click OK to save the settings and close the dialog box. If you do not want to make changes, click Cancel to close the Properties dialog box.
- 7 If you change the port, reboot the PC and power cycle the printer.



Use the Printing Preferences dialog box

Make sure the printer power is on and the printer is connected to the PC.

- 1 Select Start from the Windows 2000 taskbar.
- 2 From the Windows Start menu, select Settings and then Printers. The Printers window appears.
- 3 Click once on the Select printer driver icon.
- 4 Select File from the Printers menu bar, and then select Printing Preferences. The Select Printing Preferences dialog box appears.

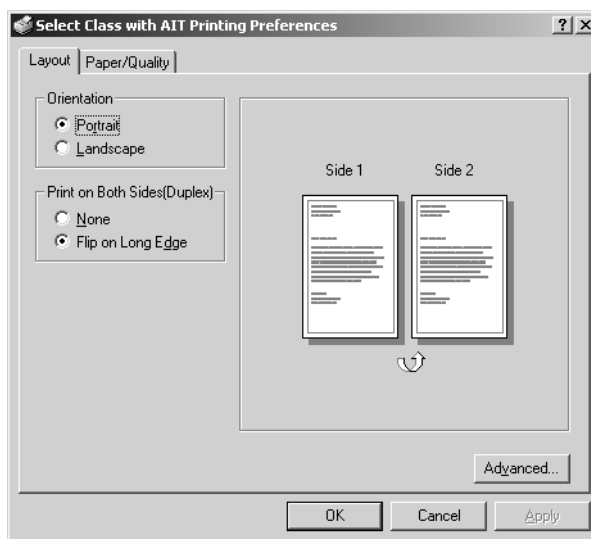

Figure 3-5: Printing Preferences dialog box for Windows 2000

- 5 If the setting you want to change appears, then select the setting.

If the setting you want to change does not appear, click the Advanced button to display the Advanced Options dialog box. Click the plus sign (+) to see all selections available. When you click a selection, a list of choices appears next to the selection. Click the arrow on the box to see the selections available.

- i** Select the Print on Both Sides setting before selecting the Print Ribbon Type and Topcoat Pattern. The choices available for Print Ribbon Type and Topcoat Pattern depend on the Print on Both Sides setting. If you change the Print on Both Sides setting after selecting YMCKTKT ribbon, the Print Ribbon Type value will be blank.



- i** If the selections you want to use are not available (are grayed out), make sure the feature is available in the printer. Also make sure that the printer is powered on and connected to the PC and resume the Status Monitor. See “Opening and using the Status Monitor” on page 3-10. For a network-connected printer, see the *e-Guide for ImageCard® Select™ and UltraGrafix® Select™ Printers*.
 - i** To view help for settings, click on the What's This help button **?** and then click any setting in the Printer Features list. A list of settings is displayed. Select the setting for which you want help.
- 6 If you make changes, or if this is the first time you have viewed the Printing Preferences dialog box, click OK to save the settings and close the dialog box.



Using the Status Monitor

The Status Monitor tracks communication between the Select printer and its printer driver. The Status Monitor icon is located in the lower right corner of the Windows desktop (see Figure 3-6).



Figure 3-6: Status Monitor icon

The Status Monitor icon shows the state of communication between them, listed in the table below.

Table 3-1: Status Monitor icons







Icon	Description	Indicates
	This Status Monitor icon is white with blue.	The Status Monitor is active and communicating with the printer.
	This Status Monitor icon is gray.	The Status Monitor is suspended and not monitoring the printer for status, including errors. The Status Monitor automatically suspends when the Select printer is powered off or disconnected.

Table 3-1: Status Monitor icons

	This Status Monitor icon is white with a white exclamation point in a red circle.	The Status Monitor is active but is not communicating with the printer. The printer might be off, cables might be loose, or a problem might exist.
	This Status Monitor icon is white with a blue magnifying glass.	The Status Monitor is in advanced setup mode. i Use advanced setup when changing color settings, monochrome printing intensity, or position of printing.
	The Status Monitor icon is white with a yellow arrow.	The Status Monitor is running at a network-connected client PC. i The Status Monitor displays the client status and advanced setup provides access to color settings.
	The Status Monitor icon is white with a green strip.	The Status Monitor is active and communicating on a PC connected to the printer using a Direct Network Kit.
	The Status Monitor icon is white with a green strip and yellow triangle.	The Status Monitor is attempting to communicate with a printer attached using a Direct Network Kit but the network is not responding.

Use the Help button on the Status Monitor for more information about each window.

Opening and using the Status Monitor

You can use the Status Monitor to do the following:

- View Status Monitor information
- Run a cleaning cycle (see “Maintaining the printer” on page 4-1)
- Suspend the Status Monitor
- Exit the Status Monitor
- Start or quit advanced setup



Open the Status Monitor

- Double-click on the Select Status Monitor icon (see Figure 3-6). The Status Monitor appears.

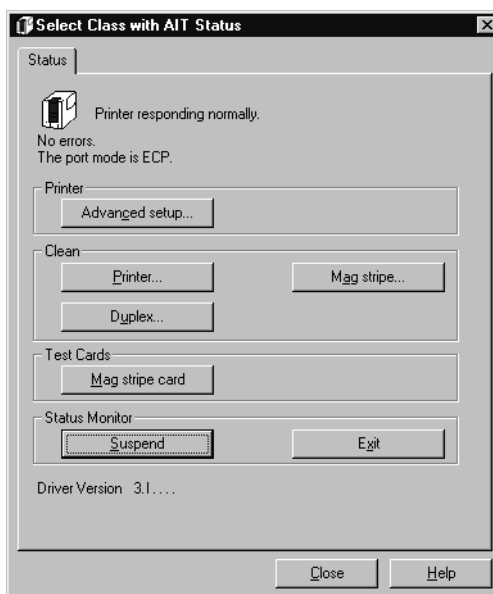

Figure 3-7: Status Monitor

Viewing Status Monitor information

The Status Monitor displays the following status information:

- The top line displays the current state of the Status Monitor or printer.
- If the printer is directly connected to this PC, the second line displays any messages. If the printer is shared through a network, this line indicates where to find information about messages.
- The third line displays the current port mode, which can be ECP, USB, Shared Mode, or Directly Networked.

Suspending the Status Monitor

Suspending the Status Monitor closes the dialog box and stops communication between the printer and driver.

To suspend the Status Monitor, double-click on the Status Monitor icon and select Suspend. Suspend the Status Monitor before power off to avoid interrupted communication.

- **i** You cannot suspend the Status Monitor while printing a card.

The Status Monitor automatically resumes when you print a card, or when you open Properties, Document Default Properties, or Printing Preferences.

Closing and Exiting the Status Monitor

Closing the Status Monitor closes the Status Monitor dialog box. The program continues to run. Exiting the Status Monitor stops the Status Monitor (program) and closes the Status Monitor dialog box.

To exit or stop the Status Monitor, double-click on the Status Monitor icon and select Exit. You should exit the Status Monitor when you receive instructions to do so.

- ❗ You cannot exit the Status Monitor while printing a card.

The Status Monitor automatically restarts when you print a card, or when you open Properties, Document Default Properties, or Printing Preferences. If you need to restart the Status Monitor, open Properties, see “Working with printer settings and data” on page 3-2.

Starting or quitting advanced setup

The Advanced Setup button on the Status Monitor changes the printer driver from printing mode to advanced setup. After you start advanced setup, additional tabs appear on the Status Monitor.

- ❗ You cannot start advanced setup while printing a card. Wait until all cards are printed, and then click Advanced Setup.

In advanced setup, you can change color settings, printing intensity, and position of printing. For network-connected PCs, you can only change color settings.

- ❗ From directly networked PCs, color settings affect cards sent from the PC. Other tabs also affect settings in the printer. It is recommended that these settings for networked PCs be changed only from an Administration PC.



Color settings (see Figure 3-8) are one of the features of Advanced Imaging Technology.

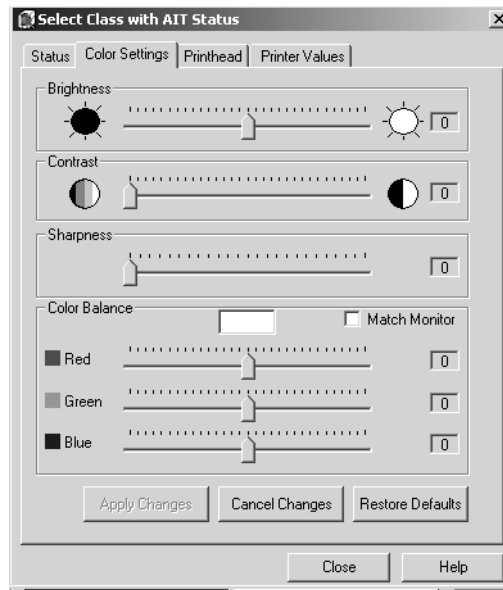

Figure 3-8: Color Settings page

For information about using the features available in advanced setup, see the *e-Guide for ImageCard® Select™ and UltraGrafix® Select™ Printers*.

While in advanced setup, the button on the Status page is named "Quit Advanced Setup." Click the Quit Advanced Setup button to remove the additional tabs and return to printing mode.



Maintaining the printer

4

This chapter provides information to help you maintain the Select™ Class printer with Advanced Imaging Technology for optimal performance. It describes:

- How to run a cleaning cycle
- How to use the magnetic stripe cleaning card
- How to clean the rollers in the printer
- How to clean the printhead
- How to replace the printhead cartridge

The print area of the printer requires regular cleaning. Other areas of the printer, such as a magnetic stripe module, duplex module, or specific rollers, might need cleaning from time to time. You can schedule such cleaning or you can clean other areas of the printer only when messages suggest the cleaning as a solution to problems. See each section for the cleaning frequency.

Running a cleaning cycle

A cleaning cycle includes replacing the sleeve of the continuous cleaning roller and running a cleaning card. Replace the cleaning roller first, and then run a cleaning card.

Select one of the following primary methods to make sure cleaning occurs regularly.

- You can set the cleaning interval in the driver to indicate when it is time to clean. The default “Cards between cleaning” value is 250 cards. You can change the number of cards between cleaning in the printer Properties, Default Document Properties, or Printer Preferences dialog box. See “Working with printer settings and data” on page 3-2 for the steps to follow.
- You can clean the printer when you change the print ribbon, when you load cards in the card cartridge, or at another regular interval you determine.

You might want to run a cleaning cycle more often if:

- The cards, especially magnetic stripe cards, have particles on them
- A monochrome ribbon is used
- The printer is operated in a relatively dirty environment
- Printed cards have defects in the printing because of residue on the card

Replacing the cleaning roller sleeve

Replace the sleeve of the continuous cleaning roller when prompted or according to your schedule. You can change the replaceable cleaning sleeve at any time, whether or not you have been prompted.

Replace the cleaning roller

- 1 Open the top cover of the printer.
 - i** The printer power can be on or off when you replace the cleaning roller.
- 2 Press down on the swing arm (step 1 in Figure 4-1). The push latch releases the swing arm. Lift the swing arm until it is fully open (step 2 in Figure 4-1).

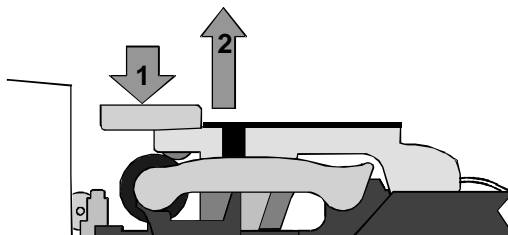

Figure 4-1: Open the swing arm

- 3 Remove the print ribbon cartridge.

- 4 Lift the continuous cleaning roller unit out of the printer (step 1 in Figure 4-2).

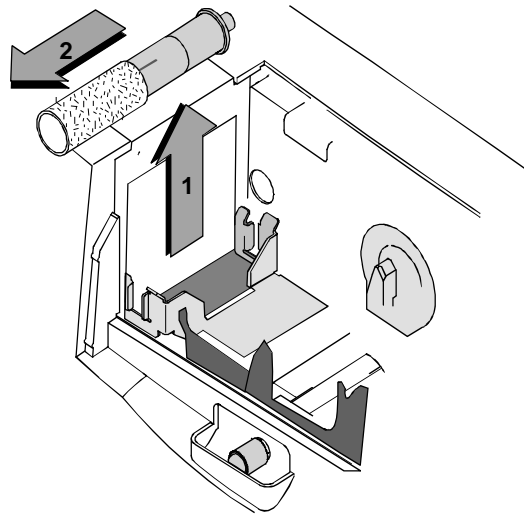

Figure 4-2: Lift the roller out of the printer

- 5 Slide the used sleeve off the cleaning roller spindle (step 2 in Figure 4-2). Discard the used sleeve.
- 6 Slide a new replaceable cleaning sleeve onto the spindle (step 1 in Figure 4-3).

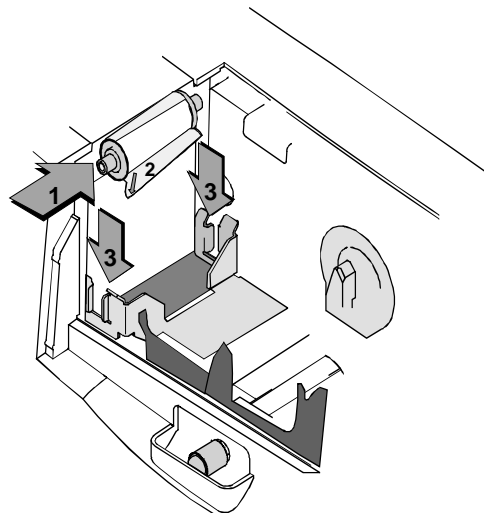

Figure 4-3: Replace the cleaning roller sleeve

- 7 Hold the replaceable cleaning roller spindle by the ends and remove the protective cover from the sleeve (step 2 in Figure 4-3). Discard the protective cover.
 - ❗ Avoid touching the sticky surface of the replaceable sleeve. Oils from your fingers could reduce cleaning and could affect card quality.
- 8 Continue to hold the spindle by the ends. Replace the spindle with sleeve in the printer (step 3 in Figure 4-3).

- 9 Replace the print ribbon cartridge.
- 10 Close the swing arm, pressing it down until the push latch clicks into place.
- 11 Close the printer top cover.



Using the printer cleaning card

Use the printer cleaning card when prompted or according to schedule. You can run a printer cleaning card whenever you are not printing, whether or not you have been prompted.

Run a printer cleaning card

- ❗ If the printer has a locking card cartridge, unlock the cartridge before removing it.
- 1 Remove the card cartridge and set it aside.
 - ❗ If the print ribbon sticks to the printer cleaning card, remove the print ribbon and repeat this procedure with a new printer cleaning card.
 - 2 Peel the protective paper backing from both sides of the printer cleaning card (see Figure 4-4).

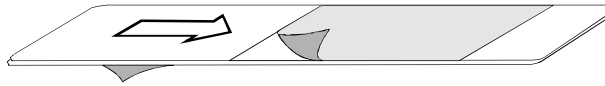

Figure 4-4: Printer cleaning card

- 3 Insert the printer cleaning card on the input rollers, which you can see after removing the card cartridge (see Figure 4-5).

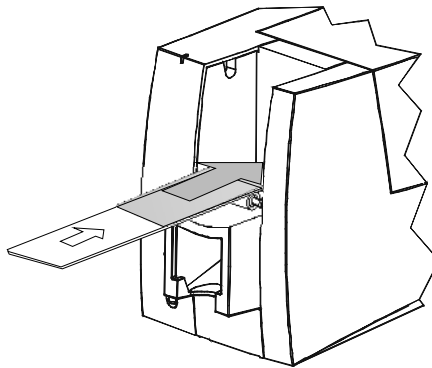

Figure 4-5: Insert the printer cleaning card

- 4 Start a cleaning cycle by doing one of the following:

- Click the OK button when the printer driver displays the “printer has reached the cleaning count” message. (If you do not click OK, the message appears each time you print a card, until you use the printer cleaning card.)
- Open the Status Monitor by double-clicking the icon. Click the Printer button in the Clean area and then the OK button.

The printer pulls in the cleaning card and moves it back and forth to clean the print area.

- 5 The cleaning card is ejected into the output stacker under the card cartridge.
- 6 Discard the used printer cleaning card.
- 7 Replace the card cartridge. Push the bottom of the card cartridge until it clicks into place. The printer module is cleaned and the printer is ready to resume normal operation.

i If the printer has a locking card cartridge, lock the cartridge after replacing it.



Using the magnetic stripe cleaning card



The printer's magnetic stripe module should be cleaned when the printer has displayed several magnetic stripe errors that list running the magnetic stripe cleaning card as a solution.

⚠ Do not use the magnetic stripe cleaning card more than once every 2000 cards or excessive wear can result.

Run the magnetic stripe cleaning card

- 1 Insert a magnetic stripe cleaning card into the exception card slot. Make sure the arrow is on top and pointing into the printer (see Figure 4-6). (You can also remove the card cartridge and place the cleaning card on the card input rollers.)

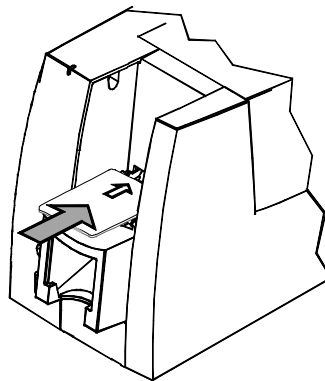

Figure 4-6: Insert the magnetic stripe cleaning card

⚠ Do not peel off the blue stripe on the back of the card.

- 2 Open the Status Monitor by double-clicking the icon.
- 3 Click the Mag Stripe button in the Clean area.



The printer automatically runs the magnetic stripe cleaning process and ejects the card in the output stacker when it is complete.

- 4 Remove the used magnetic stripe cleaning card. The card can be used again.



Cleaning the printer rollers

The rollers in the printer move the card into position to begin operations, such as printing, and move the card during operations. Clean the rollers once a week or when problems occur, such as repeated card jams or cards not being picked.

To clean rollers, use the cleaning pen.

Clean printer rollers

- 1 Open the Status Monitor by double-clicking the printer icon.
 - ⓘ Make sure that printing of cards is complete before cleaning the rollers.
- 2 Clean the two pick rollers:
 - ⓘ If the printer has a locking card cartridge, unlock the cartridge before removing it.
 - a Remove the card cartridge.
 - b Remove the cap from the cleaning pen. Hold the end of the cleaning pen against the first pick roller (step 1 in Figure 4-7).

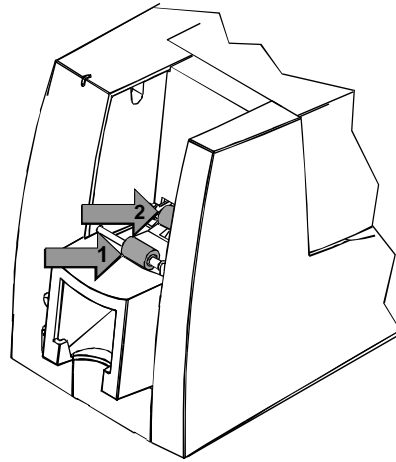

Figure 4-7: Clean the pick rollers

- c Click the “Printer” button in the Clean area. Click OK on the prompt that appears. Do not insert a cleaning card! The driver sends a command to the printer to run the printer cleaning card. The printer moves rollers when it attempts to pick the card.
 - d Slowly move the pen on the pick roller.
 - e Lightly wipe any dirt from the end of the cleaning pen onto a clean cloth or paper. Move the cleaning pen to another area of the roller.
 - f Repeat steps c through e until no more dirt appears on the pen.
 - g Repeat steps c through f, placing the cleaning pen on the second pick roller (step 2 in Figure 4-7).
- 3 Clean the transport area rollers:
- a Open the cover and remove the print ribbon cartridge. The card cartridge should stay out of the printer.
 - b Place the cleaning pen on top of the first transport roller (location 1 in Figure 4-8).

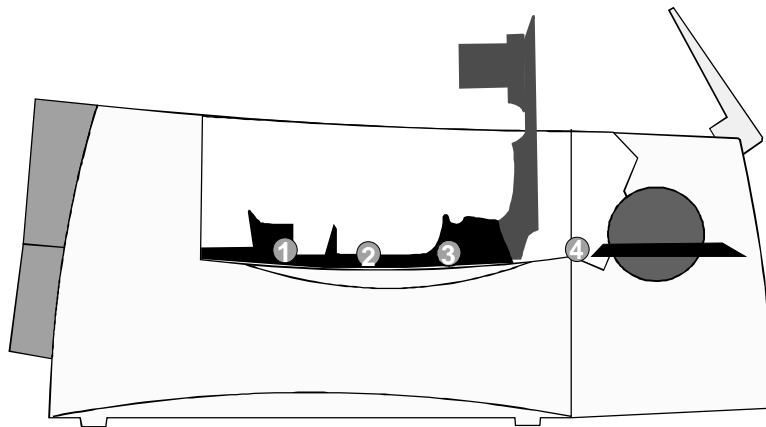

Figure 4-8: Clean rollers in the card track

- i** Do not place the pen next to the black transport base. The pen can get pinched between the roller and the transport base.
 - c Do one of the following to turn the rollers in the printer.
 - Click the “Printer” button in the Clean area. Click OK on the prompt that appears. Do not insert a cleaning card! The driver sends a command to the printer to run the printer cleaning card. The printer moves rollers when it attempts to pick the card.
 - Turn the card advance knob to move rollers by hand.
 - d Move the pen on the roller.
 - e Lightly wipe any dirt from the end of the cleaning pen onto a clean cloth or paper. Move the cleaning pen to another area of the roller.
 - f Repeat steps c through e for the roller at location 1 until no more dirt appears on the pen or cloth.
 - g Move the cleaning pen to location 2 (in Figure 4-8). Repeat steps c through f.
 - h If the printer has a magnetic stripe module, move the cleaning pen to location 3 (in Figure 4-8). Repeat steps c through f.
 - i Replace the print ribbon cartridge and close the swing arm.
If the printer does not have a duplex or smart card module, Go to step 5.
If the printer has a duplex or smart card module, continue with step 4.
- 4 If the printer has a duplex module or a smart card module, clean the exit roller.
- a Begin with the swing arm down and latched, and the module door open.
 - b Insert the cleaning pen through the module door and hold the end of the cleaning pen against the top of the lower exit roller (location 4 in Figure 4-8).
 - c Do one of the following to turn the rollers in the printer.
 - Click the “Printer” button in the Clean area. Click OK on the prompt that appears. Do not insert a cleaning card! The driver sends a command to the printer to run the printer cleaning card. The printer moves rollers when it attempts to pick the card.
 - Turn the card advance knob to move rollers by hand.
 - d Move the pen on the roller.
 - e Lightly wipe any dirt from the end of the cleaning pen onto a clean cloth or paper. Move the cleaning pen to another area of the roller.
 - f Repeat steps c through e for the roller at location 4 until no more dirt appears on the pen or cloth.
 - g Close the printer top cover and the module door.
- 5 Replace the card cartridge.
- i** If the printer has a locking card cartridge, lock the cartridge after replacing it.



- 6 Print a card to verify the quality of printing. You can print a printer test card, a sample card, or a card using your card creation application.



Cleaning tips

Follow these tips to clean your printer effectively and maintain optimum operation.

- Clean the ribbon tracker using the printer cleaning pen.
- Some card features can require more frequent cleaning of the printer, especially if the cards are not high quality. Signature panels and magnetic stripes can deposit particles on rollers. Use the prompted cleaning cycle more often than the default of every 250 cards.
- Clean printer rollers regularly, such as daily or every 1000 cards. If your printer is connected over a network using a print server, the cleaning frequency set in the printer will apply to cards sent from all attached PCs.
- If you use StickICards, clean the card tracks after every 100 cards. Use the cleaning pen to reach most areas of the card track. Use an isopropyl alcohol swab (not included in the cleaning kit) to reach hidden areas of the card track.

Cleaning the printhead

The printhead can have contamination stuck to it. You might notice it as unprinted lines on printed cards. Clean the printhead only when needed, such as:

- The printhead has been accidentally touched, such as when changing supplies or cleaning a card jam
 - You have replaced the printhead
 - You observe problems with card appearance
- ⚠ Do not touch the printing edge of the printhead cartridge with your fingers. The oils on your fingers can damage the printhead.
- ⚠ Do not bump the printing edge of the printhead cartridge with any sharp objects. Sharp objects can permanently damage the printhead.

Use the cleaning pen to clean the printhead. Do not use a cotton swab. The fibers from the cotton can stick to the printhead.

Clean the printhead

- 1 Power off the printer, and disconnect it from the power source.
- 2 Press down on the swing arm. The push latch will release the swing arm. Lift the swing arm until it is fully open.

- 3 Open the cleaning pen.
- 4 Using gentle pressure, move the cleaning pen back and forth along the full length of the printhead edge (see Figure 4-9). Be sure to clean the rounded edge of the printhead completely.

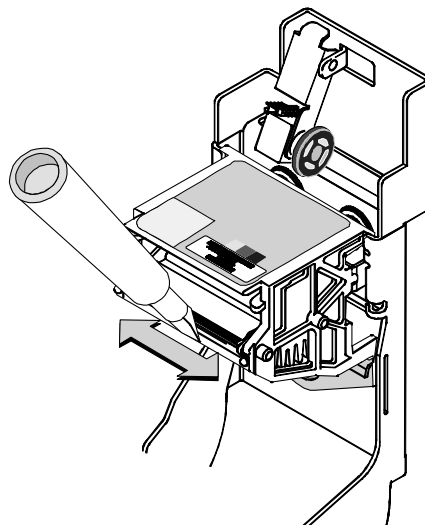

Figure 4-9: Clean the printing surface of the printhead

- i** If the cleaning pen does not remove all contamination from the printhead, contact your service provider for additional assistance.
- 5 Close the swing arm, pressing it down until the push latch clicks into place.
- 6 Connect the power cable to the power source and power on the printer.
- 7 Print a card to verify the quality of printing. You can print a Windows test page or a card using your card creation application. If card quality is still inadequate, see the *e-Guide for ImageCard® Select™ and UltraGrafix® Select™ Printers*.



Replacing the printhead cartridge

The Select printer uses an operator-replaceable printhead cartridge. For more information about printhead cartridges, see the *e-Guide for ImageCard® Select™ and UltraGrafix® Select™ Printers*.

Remove the printhead cartridge

- ⚠ Do not touch the printing edge of the printhead cartridge. If you do, clean it using the cleaning pen, as described in “Cleaning the printhead” on page 4-9.
- ⚠ Do not bump the printing edge of the printhead cartridge with any sharp objects. Sharp objects can permanently damage the printhead.



User's Guide for ImageCard® Select™ and UltraGrafix® Select™

- 1 Power off the printer.
- 2 Open the top cover.
- 3 Push down on the swing arm. The push latch will release the swing arm. Lift the swing arm up until it is fully open.
- 4 Press down on the green printhead cartridge latch to release the printhead (step 1 in Figure 4-10).

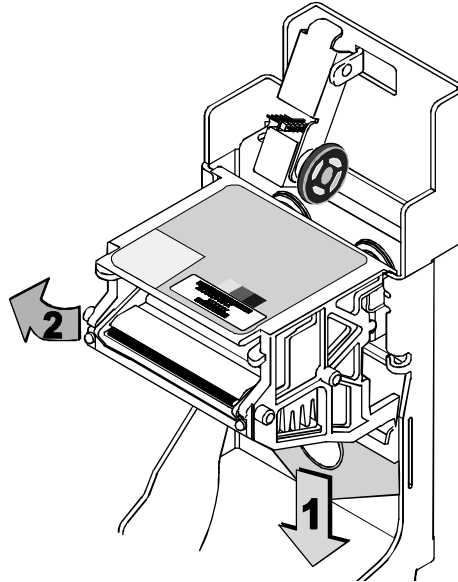

Figure 4-10: Printhead cartridge latch lever

- 5 Lift the printhead cartridge up and off the swing arm (step 2 in Figure 4-10).

- 6 Remove the printhead cables.
 - Push the black locking tabs to the side. Remove the gray connector of the printhead data cable from the printhead cartridge (see Figure 4-11).
 - Pull firmly on the white connector of the printhead power cable to remove it from the printhead cartridge. You can gently pull on the wires attached to the plug if needed to remove the cable.

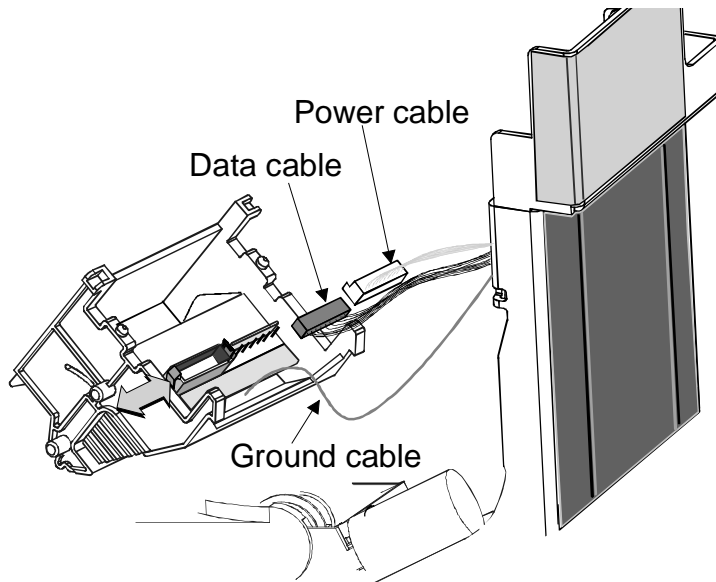

Figure 4-11: Printhead power and data cables and connectors

- 7 Remove the ground cable connector from the ground tab of the swing arm by pulling on the red sleeve (see Figure 4-12).

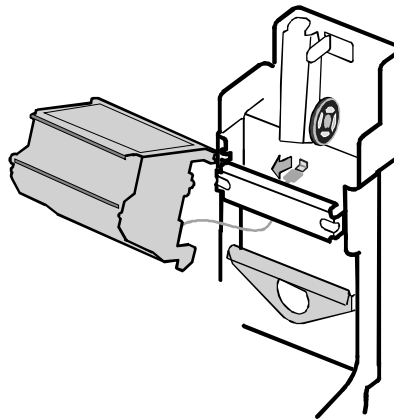

Figure 4-12: Printhead ground cable



Replace the printhead cartridge

- 1 Carefully align the openings on the (white) power cable plug with the wires of the power receptacle on the printhead. Push the cable's plug all the way onto the receptacle (see Figure 4-11).
- 2 Push the (gray) data cable plug into the new printhead cartridge (see Figure 4-11). Make sure the locking tabs are in place.

⚠ Do not press on the wires of the printhead cables.

- 3 If the printhead has a ground cable, slide the ground cable connector onto the ground tab of the swing arm (see Figure 4-12).
- 4 Align the printhead cartridge pins with the printhead cartridge slots on the swing arm (see Figure 4-13).
- 5 Slide the new printhead cartridge onto the swing arm, so the pins slide into the slots (see Figure 4-13).

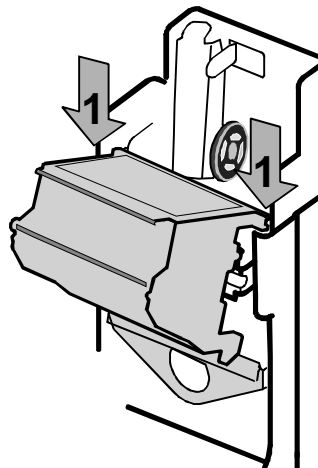

Figure 4-13: Align pins with slots on the swing arm

- 6 Align the notches on the printhead cartridge with the notches on the spring bar (1 in Figure 4-14).

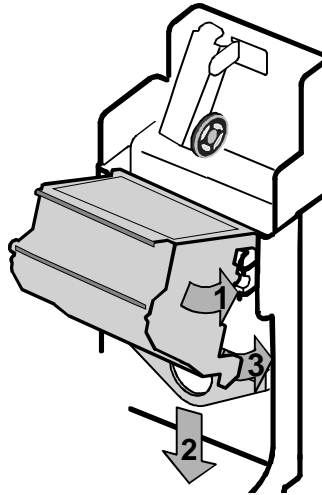

Figure 4-14: Secure the printhead cartridge

- 7 Hold the printhead cartridge latch lever down (step 2 in Figure 4-14) and pivot the printhead cartridge down toward the swing arm (step 3 in Figure 4-14). Release the latch lever when the printhead cartridge is in place.
- 8 Clean the printhead. Move the cleaning pen back and forth along the length of the printhead edge. (See Figure 4-9 on page 4-10.) Be sure to completely clean the rounded edge of the printhead.
- 9 Close the swing arm, pressing it down until the push latch clicks into place.
- 10 Close the cover and then power on the printer.
- 11 Print a card to verify the quality of printing. You can print a sample card or a card using your card creation application. If card quality is still inadequate, see the *e-Guide for ImageCard® Select™ and UltraGrafix® Select™ Printers*.



Troubleshooting

5

This chapter explains how to troubleshoot the Select printer with Advanced Imaging Technology™ and how to obtain service. It explains:

- What to do if you think the printer is not working
- How to make test cards
- Problems you might see in the appearance of cards
- How to obtain service
- How to package the printer to return for service

When you experience problems using the printer, follow the guidelines in this chapter.

- Record the printer model serial number. The model and configuration are displayed on a label that is visible when you open the top cover.
- Keep notes on the problem, including the message number and the solutions you attempt.
- Obtain information about the supplies used, including:
 - Card stock and type (such as composite or PVC, three-track magnetic stripe, manufacturer, and so on). This information is located on the packaging for cards.
 - Type of ribbon (such as YMCKT) and the lot number used for personalizing cards. This information is located on the package of the ribbon.

If you need to call for service, this information will help your service representative address your concerns.

For more information about messages, see “Responding to messages” on page 2-11.

Troubleshooting guide

When you use the Select printer, you might experience problems. Use the following to help you locate information for different types of problems.

Problem	Location
Printer beeps without a message displayed on the PC	See "Responding to messages" on page 2-11.
Installation problems	See "Install the printer" on page 7-1.
Appearance of printed cards	See "Problems with card appearance" on page 5-7.
Communication between PC and printer (parallel port)	See "Setup tips" on page 7-16.
Communication between PC and printer (USB)	See the <i>e-Guide for ImageCard® Select™ and UltraGrafix® Select™ Printers</i> .
Messages displayed on the PC	Click the Help button on the message box.
Printer beeps because of a problem and a message is displayed on the PC	Click the Help button on the message box.
Card did not print as expected	See "Working with printer settings and data" on page 3-2 and the <i>e-Guide for ImageCard® Select™ and UltraGrafix® Select™ Printers</i> .

If you think the printer is not working

The printer, printer driver, and card creation application work together to produce cards. If the system is not working as you expect and does not display messages, follow these steps to isolate the source of the problem before contacting your service representative.

- 1 Make a printer test card, following the steps in "Making and evaluating test cards" on page 5-3.
If the printer does not make a test card, the printer is likely not working properly.
- 2 Print a Windows test page, following the steps in "Making and evaluating test cards" on page 5-3.
If the Windows test page does not print as expected, the printer driver is likely not set or operating properly.
- 3 Check "Setup tips" on page 7-16 to make sure the PC and printer are set up correctly.



- 4 Make sure the printer is the selected printer in the card creation application. Print a sample card using the card creation application or see “Printing sample cards” on page 7-15.

If the sample card does not print the card as expected, the card creation application is likely not set or operating properly.

Making and evaluating test cards

You can make the following types of test cards.

- Printer test cards verify the function of the printer. You print them using controls on the printer. The personalization of the card is determined by the printer, the print ribbon, and modules (such as magnetic stripe or duplex) installed in the printer.
 - The Windows test page, which you can print on a card, verifies that the PC and printer work together. You print them using the printer Properties dialog box on the PC. The appearance of the card is determined by Windows.
 - Printer magnetic stripe test cards, which verify that the driver sends magnetic stripe information to the printer and verifies that it is encoded. Use controls in the Status Monitor to print magnetic stripe test cards.
- i** You can also make sample cards, using driver files or your card creation application to test print quality and card design. See “Printing sample cards” on page 7-15.

Follow these steps to make printer test cards on all supported Windows operating systems.

Make a printer test card

- i** The Select printer does not need to be connected to a PC to print this card.
- 1 Power off the Select printer.
 - 2 Confirm that all supplies are loaded. See “Loading cards” on page 2-2 if needed.
 - i** If the printer has a magnetic stripe module, the cards for a printer test card must have a magnetic stripe. If it is a three-track module, be sure to use the high coercivity blank cards shipped in the supplies kit.
 - 3 Press and hold the Ready button (1), and then power on the Select printer (2) as shown in Figure 5-1. Hold the Ready button until the printer sounds three tones, usually 5 to 10 seconds.

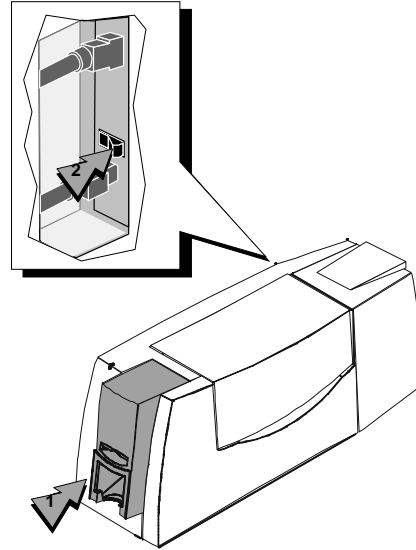

Figure 5-1: Press and hold Ready button (1) and then Press Power switch (2)

- 4 Release the Ready button. You hear the internal components initialize. Allow 30 to 60 seconds for the printer to begin printing the test card. The status light will flash green while the Select printer is processing the data.

A printer test card is shown in Figure 5-2 on page 5-4.

If the printer test card did not print successfully, see “Status light” on page 2-7.



Printer test card

The printer test card is designed to perform most of the functions available in the printer.

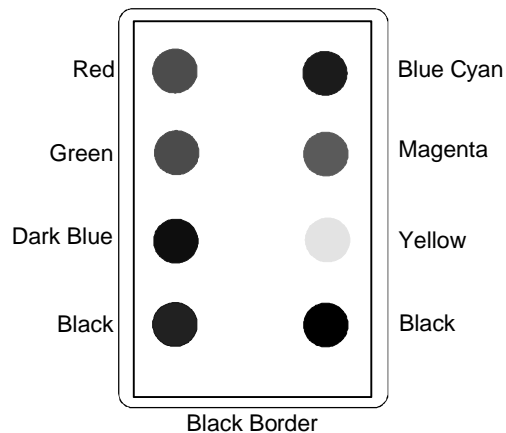

Figure 5-2: ImageCard printer test card (using color ribbon)

- i** Your service provider might ask you to use a different procedure to make a printer test card. The card printed might have additional area printed on it. For UltraGrafix printers, the test card is printed with one color, such as black.

Check the following:

- The test card has the pattern shown on the front of the card. The back of the card will be printed with a similar pattern if the printer includes a duplex module.
- If a magnetic stripe module is installed in the printer and enabled, the following data is encoded on the card:



Track	Format	Data
Track 1	(IATA)	TEST PATTERN IATA CHARACTER SUBSET 0123456789
Track 2	(ABA)	012345678012345678990123456789
Track 3	(TTS)	0123456789=9876543210
Track 3	(NTT)	0123456789=9876543210

See “Magnetic stripe encoding” on page D-1 for more information about magnetic stripe tracks.

- The tracks available depend on the type of module installed.
- The magnetic stripe data on the printer test card is generated by the printer and does not test driver-to-printer communication.

If you are not satisfied with the appearance of the test card, see “Problems with card appearance” on page 5-7 to identify the problem and possible solutions.

Windows test page

Follow these steps to print a Windows test page on all supported operating systems.

Print the Windows test page

- i** The Select printer must be connected to the PC with the driver installed, and both printer and PC must be running.
- Select Start from the Windows taskbar.
 - Select Settings and then Printers from the Windows Start menu. The Printers window appears.
 - Click once on the Select printer icon.
 - Select File from the Printers menu bar, and then select Properties. The Select Properties dialog box appears.

- 5 Select the Print Test Page button on the General tab. Wait while Windows creates a test page image. The card will print when the PC and printer are connected, and the printer and driver are working together.
- i** After you select the Print Test Page button, Windows displays a wizard asking if the page printed correctly. Click “Yes” on this dialog box to end the Wizard. The “Setup tips” on page 7-16 provide the information you need to address problems with PC to printer communication.

The card should look similar to the cards shown in Figure 5-3 and Figure 5-4. The exact appearance depends on the operating system and selections made on the PC (some cards have more characters printed while others have fewer characters).

If it does not print, see “Setup tips” on page 7-16.

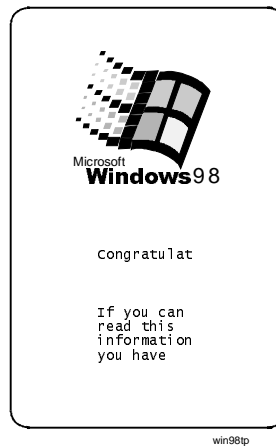

Figure 5-3: Windows test page, portrait orientation

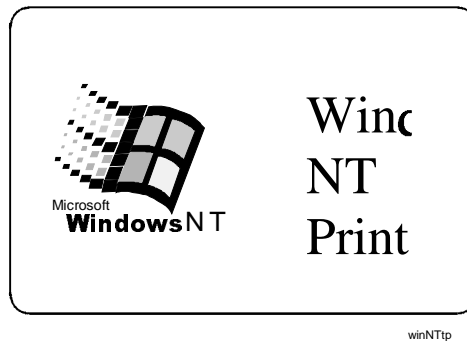

Figure 5-4: Windows test page, landscape orientation

The Windows test page has a slightly different appearance when it is printed from a network-connected client PC.

- ❗ The Windows test page is generated by Microsoft Windows. The small size of the card, compared to printer paper, means that some of the text is not printed on the card.



Magnetic stripe test card

If the printer includes a magnetic stripe module, you can print a magnetic stripe test card. The card uses the magnetic stripe settings in the Properties, Default Document Properties, or Printing Preferences dialog box.

Use this card to verify that the printer encodes a card correctly.

Print a magnetic stripe test card

- ❗ The Select printer must be connected to the PC with the driver installed, and both printer and PC must be running.

- 1 Double-click the printer icon in the System tray.  The Status Monitor opens.
- 2 Make sure that magnetic stripe cards are loaded in the card cartridge. (See “Loading cards” on page 2-2 for information on loading cards.)
- 3 Click once on the Mag Stripe Test button. The printer driver formats card data for the type of module installed, as follows:
 - Three-track: IAT formatted data (IATA data on track 1, ABA data on track 2, and TTS data on track 3)
 - NTT track: NTT formatted data on the track
- 4 Test the card by passing it through a card reader that will display the data encoded on the card. The encoded data should match the data printed on the test card.



Problems with card appearance

Problems with card appearance can be the result of the following:

- Image capture tools, such as the camera
- Card creation application, which displays the image
- Limitations in technology, such as differences between how an image looks on the monitor and how it looks after it is printed
- Printer maintenance or PC settings

- i** New Select printers include Datacard's Advanced Imaging Technology™ (AIT). Cards printed with Advanced Imaging Technology have a different appearance than cards printed with earlier Select printers, including those with Tru Image™.



This section describes possible problems you might observe with the quality of cards you produce with the Select printer. To diagnose and fix card quality problems, find the symptom in the tables that follow. For each possible cause, attempt the solutions listed.

Problem	Troubleshooting
Print quality	Table 5-1 on page 5-8
Topcoat quality—print ribbon	Table 5-2 on page 5-13

Print Module

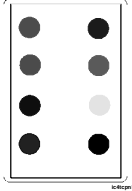

Table 5-1 and Table 5-2 describe problems that can originate in the print.

Table 5-1: Print quality problems

What you see	Possible causes	Solutions
<p>One or more unprinted lines run the entire length of the card.</p> 	<p>The printhead might be dirty or damaged.</p>	<p>Clean the printhead. See Run a test card. See this chapter.</p> <p>If cleaning does not solve the problem, replace the printhead. See Chapter 4.#</p>
<p>Part of the printed card is blank.</p> 	<p>Cards might not meet specifications.</p> <p>Cards might be dirty.</p> <p>Text to print on the card was formatted using a non-TrueType font.</p>	<p>Obtain and use a different supply of cards. See Appendix B.</p> <p>Increase the frequency of cleaning. See Chapter 3. Run a cleaning cycle. See Chapter 4.</p> <p>Format text to print using only TrueType fonts.</p>

Obtain guidance from service before performing this task.

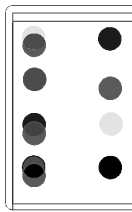
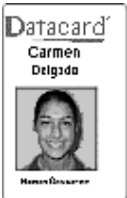

Table 5-1: Print quality problems

What you see	Possible causes	Solutions
<p>The leading or trailing edge of the printed card is not the expected color.</p> 	<p>Cards might be slipping in the card track.</p> <p>Two cards might have been picked.</p> <p>The print ribbon might not be Datacard-recommended.</p> <p>The ribbon registration might be incorrect.</p>	<p>Run a cleaning cycle, then clean the rollers. See Chapter 4.</p> <p>Fan cards before inserting them in the card cartridge.</p> <p>Obtain and use Datacard-recommended print ribbon. See Appendix B.</p> <p>Contact your service representative. See the <i>e-Guide</i>.</p>
<p>No image is printed on the card or the printing is very light.</p> 	<p>The ribbon is loaded incorrectly.</p> <p>The printhead cartridge power cable might be loose.</p> <p>The printhead cable or printhead cartridge might be damaged.</p>	<p>Remove and replace the ribbon. See Chapter 2.</p> <p>Power off the printer. Make sure the printhead power cable is securely connected. See Chapter 4.</p> <p>Replace the printhead. See Chapter 4.[#]</p> <p>If the problem persists, contact your service representative.</p>
<p>One color panel is not aligned correctly with other panels.</p> 	<p>Cards might be slipping in the card track.</p> <p>The card registration might be incorrect.</p>	<p>Run a printer cleaning cycle, then clean the rollers. See Chapter 4.</p> <p>Set the position of printing. See the <i>e-Guide</i>.[#]</p> <p>If the problem persists, contact your service representative.</p>

[#] Obtain guidance from service before performing this task.

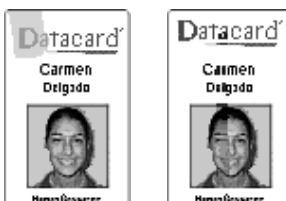
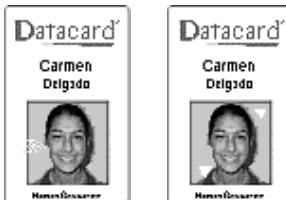

Table 5-1: Print quality problems

What you see	Possible causes	Solutions
<p>Printed card images (photos) are blurry. Printed cards, including text, are blurry.</p>	<p>The image capture system needs adjustment. The rollers may be dirty. The cards may not meet specifications. The printhead may be dirty.</p>	<p>See the information for the image capture system. Run a cleaning cycle, then clean the rollers. See Chapter 4. Obtain and use a different supply of cards. See Appendix B. Clean the printhead. See Chapter 4. If the problem persists, contact your service representative.</p>
<p>All card data is positioned unevenly on the card.</p> 	<p>The card registration might be incorrect.</p>	<p>Set the position of printing. See the <i>e-Guide</i>.# If the problem persists, contact your service representative.</p>
<p>Card is printed upside down (the image is rotated 180 degrees).</p> 	<p>The card creation application has rotated the card. The card rotation setting might be incorrect.</p>	<p>See the information for the card creation application. Set the card rotation using the Default Document Properties (NT), Properties (98), or Printing Preferences (2000) dialog box. See .</p>

Obtain guidance from service before performing this task.



Table 5-1: Print quality problems

What you see	Possible causes	Solutions
<p>Printed card images (photos) look faded.</p> <p>Printed cards, including text, look faded.</p>	<p>The image capture system needs adjustment.</p> <p>Print ribbon may have been stored improperly or damaged.</p> <p>The might need to be changed.</p> <p>The cards may not meet specifications.</p> <p>The printhead may be dirty.</p> <p>The print ribbon is not Datacard Premium ribbon.</p>	<p>See the information for the image capture system.</p> <p>Change the print ribbon a test card. See Chapter 2.</p> <p>Change the color settings. See the <i>e-Guide</i>.#</p> <p>Obtain and use a different supply of cards. See Appendix B.</p> <p>Clean the printhead. See Chapter 4.</p> <p>Use only Datacard Premium ribbon in the Select printer with Advanced Imaging Technology.</p> <p>If the problem persists, contact your service representative.</p>
<p>Part of the printed image is discolored.</p> 	<p>Cards might have fingerprints or other dirt on them.</p> <p>The cards might be contaminated or otherwise not meet specifications.</p> <p>The rollers might be dirty.</p> <p>A signature panel is located on the other side of the card.</p>	<p>Handle cards without touching the surface to be printed. Wear gloves when handling unprinted cards.</p> <p>Obtain and use a different supply of cards. See Appendix B.</p> <p>Run a printer cleaning cycle, then clean the rollers. See Chapter 4.</p> <p>Redesign the card to avoid printing photos over signature panel residue.</p>
<p>The printed card shows small unprinted spots.</p> 	<p>The card is scratched, the card surface is uneven, or the card edge has burrs.</p> <p>The rollers might be dirty.</p>	<p>If the problem occurs frequently, obtain and use a different supply of cards. See Appendix B.</p> <p>Run a cleaning cycle, then clean the rollers. See Chapter 4.</p>

Obtain guidance from service before performing this task.

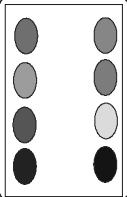
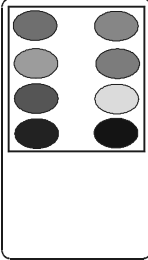

Table 5-1: Print quality problems

What you see	Possible causes	Solutions
<p>The printed card shows wavy lines along the length of the card (woodgrain).</p> 	<p>The print ribbon is not loaded correctly.</p> <p>The printhead is not aligned correctly.</p>	<p>Load the print ribbon again. Make sure the cartridge is firmly seated. See Chapter 2.</p> <p>Contact your service representative.</p>
<p>The card shows irregular lighter or darker spots.</p> 	<p>The printhead is not aligned correctly.</p>	<p>Contact your service representative.</p>
<p>The card shows wrinkles in dark areas of printing.</p> 	<p>The printhead intensity is too high.</p> <p>The printhead is not aligned correctly.</p>	<p>Decrease the printhead intensity setting. See the <i>e-Guide</i>.#</p> <p>Contact your service representative.</p>
<p>Part or all of the printed image is expanded.</p> 	<p>The printhead is not installed properly.</p>	<p>Remove and reinstall the printhead cartridge. See Chapter 4.</p>

Obtain guidance from service before performing this task.

Table 5-1: Print quality problems

What you see	Possible causes	Solutions
<p>Part or all of the printed image is compressed.</p> 	<p>The card path may be obstructed.</p> <p>The rollers might be dirty.</p> <p>The cards might not meet specifications.</p>	<p>Check the card transport track for jams. Check the duplex module (Select 2 printers only) for jams. Clear any card jams.</p> <p>Run a printer cleaning cycle, then clean the rollers. See Chapter 4.</p> <p>Obtain and use a different supply of cards. See Appendix B.</p>

Topcoat applied using the print ribbon

You might apply topcoat to the card using a T panel as part of the print ribbon.



Table 5-2: Topcoat quality problems—print ribbon

What you see	Possible causes	Solutions
<p>Random scratches appear in the topcoat of the printed card.</p>	<p>The inside of the printer might be dirty.</p> <p>Supplies were mishandled.</p>	<p>Run a printer cleaning cycle. Clean the rollers. See Chapter 4.</p> <p>Store supplies in a clean environment. Keep supplies in their packaging until loaded in the cartridge.</p>
<p>The topcoat shows bands across the width of the card.</p> 	<p>The printhead intensity is too low.</p> <p>The printhead is not aligned correctly.</p>	<p>Increase the printhead intensity setting for topcoat. See the <i>e-Guide</i>.[#]</p> <p>Contact your service representative.</p>

[#] Obtain guidance from service before performing this task.



Table 5-2: Topcoat quality problems—print ribbon

What you see	Possible causes	Solutions
<p>The topcoat shows lines along the length of the card.</p> 	<p>The printhead intensity is too high.</p> <p>The printhead is not aligned correctly.</p>	<p>Lower the printhead intensity setting for topcoat. See the <i>e-Guide</i>.#</p> <p>Contact your service representative.</p>
<p>A short edge of the topcoat does not stick to the card.</p> 	<p>The printhead intensity is too low.</p> <p>The printhead is not aligned correctly.</p>	<p>Increase the printhead intensity setting for topcoat. See the <i>e-Guide</i>.#</p> <p>Contact your service representative.</p>
<p>The card shows irregular lighter or darker spots.</p> 	<p>The topcoat panel of print ribbon is wrinkling because the intensity setting is too high.</p> <p>The printhead is not aligned correctly.</p>	<p>Lower the printhead intensity setting for topcoat. See the <i>e-Guide</i>.#</p> <p>Contact your service representative.</p>

Obtaining service

For repair assistance, contact your service representative. Place the service call from a telephone close to the printer so that you can access the printer and the PC running the driver while talking to the customer support representative.

Before you call for service, make sure you have the information recorded during troubleshooting, as described on page 5-1. Also, make sure you have the serial number of the printer. It is located on a label of the printer.

Obtain guidance from service before performing this task.



User's Guide for ImageCard® Select™ and UltraGrafix® Select™ Printers

When to obtain service

Perform the steps earlier in this chapter before obtaining service. Call for service if:

- A troubleshooting process instructs you to call service
- A troubleshooting process does not produce the expected result
- You experience a problem repeatedly

Packing the printer for shipping

When service asks you return the printer to a service center for repair, pack the printer for shipping. You might also need to pack the printer to send it to another location.

Pack the printer

- 1 Turn off power to the printer.
- 2 Remove the power cord from the printer and power receptacle. Remove the data cable and any other cables attached to the printer.
 - If you are shipping the printer to use at another location, pack the power cord, data cable, and any other cables in the accessories bag.
 - If you are shipping the printer for service, do not ship cables with the printer unless asked to do so.
- 3 Remove all cards from the card cartridge, card output stacker, and printer. Do not ship cards unless asked to do so.
- 4 Remove the continuous cleaning roller from the printer unless asked to return it. Put the spindle with other accessories, such as the User's Guide.
- 5 Secure the print ribbon cartridge. Leave the print ribbon cartridge in place or apply packing tape. Avoid applying tape to labels in the printer.
- 6 Make sure the card cartridge is firmly seated.
- 7 Close the cover.
- 8 Use the original shipping carton, plastic bag, and foam shipping supports.
- 9 Place the plastic bag around the printer. If you are transporting the printer to another location for use, put the data cable, the power cord, and any smart card serial cables in a protective bag. Place the bag in the printer bag and close it.
- 10 Put the bottom shipping supports in place. The shipping supports are labeled "Front Bottom" and "Back Bottom".

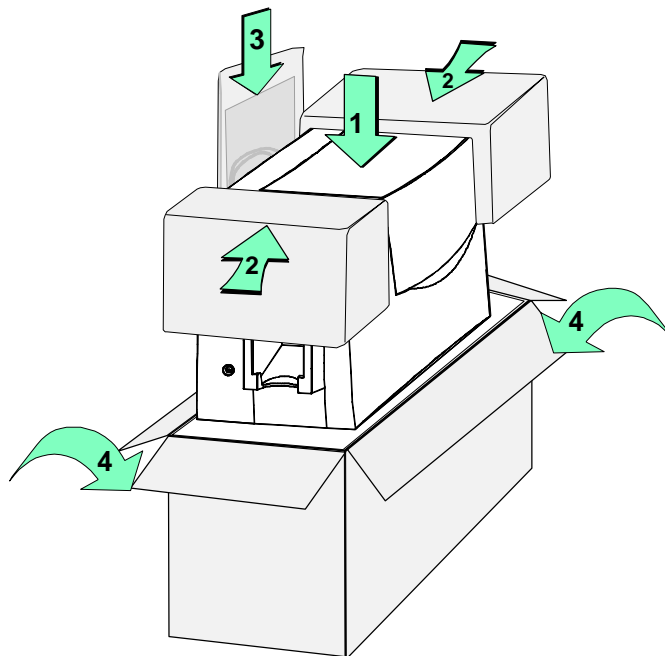

Figure 5-5: Pack a Select printer for shipping

- 11 Place the printer in the shipping carton, resting in the shipping supports (step 1 in Figure 5-5).
- 12 Place the “Top Front” and “Top Rear” shipping supports in place (step 2 in Figure 5-5).
 - i** Service might ask you to ship cards or additional samples of your current supplies. If service requests cards or supply samples, place them in an envelope, plastic bag, or in the accessory bag to prevent damage to the printer.
 - i** If you are transporting the printer to another location for use, be sure to pack the User’s Guide, printer driver CD-ROM, the warranty, and the declaration of conformity in the accessories bag.
- 13 Place the accessories bag in the shipping carton next to the printer (step 3 in Figure 5-5).
- 14 Close the shipping carton (step 4 in Figure 5-5).
- 15 Secure the carton with shipping tape. Be sure to wrap around the shipping carton several times to secure it.
- 16 Put a shipping label on the carton. If you are returning the printer for service, use the address provided by service.
- 17 Ship the carton. If you are returning the printer for service, follow the instructions provided by service to ship the carton to a service center.



Before you install

6

This chapter presents the following:

- Skills that installers need
- Physical, electrical, and other requirements for the site
- Requirements for the PC used with the Select printer with Advanced Imaging Technology™
- The preferred sequence for installing this printer as part of an identification system

Installation audience

To perform the procedures in the installation section of this guide, you need the following skills:

- Ability to read and understand written and graphical instructions
- Experience and comfort installing hardware (such as a printer, scanner, expansion card, etc.) in a personal computer (PC)
- Experience with configuring applications and ports
- Experience installing and using Microsoft® Windows® 98, Windows Me, Windows NT®, or Windows 2000 (for Windows NT and Windows 2000, the installer must have administrator access to the PC)
- Ability to perform simple troubleshooting using written and graphical instructions

If you do not feel comfortable with installing the printer, find a network support or other technical professional to install the printer.

Datacard-authorized service personnel also use this information.

General requirements

When choosing a site for the Select printer and its supplies, consider the following general requirements:

- Keep all dust, dirt, food, liquids, etc. away from the Select printer at all times.
- Keep the top cover closed at all times, except when changing supplies, fixing problems, or performing maintenance.
- Do not use supplies or cards that have been dropped on the floor or have otherwise become contaminated.
- Keep paper and foreign materials off the Select printer.
- Do not block the back air vents or fan opening on the Select printer.
- Place the Select printer on a stable platform; keep it off the floor.
- Place the Select printer away from direct sunlight.
- Place the Select printer away from heating ducts, blowers, or other air vents.
- Do not use the Select printer for purposes other than its intended use.
- When cleaning around the Select printer, prevent debris from entering the printer.
- Place the Select printer in a clean office environment, protected from any type of construction.
- Store all supplies (ribbons, cards, etc.) in the original packaging until loaded in the cartridges. Keep the original packaging closed.



- Store all supplies in a clean, cool, dry location. See “Supply roll storage” on page B-2 for information about the storage environment for Select supplies.

Selecting the site

After meeting general requirements, the site for the Select printer should meet the electrical, physical, and environmental requirements of the printer. Finally, be sure to select an appropriate site for printer supplies.

Electrical requirements

The Select printer requires the following electrical conditions for optimal performance:

- 90-254 VAC at 50/60 Hz (The Select printer automatically adjusts to any power within this range.)
- Single phase, 3-wire grounded receptacle only

The maximum input current for the Select printer is 1.4 amps at 100 VAC applied.

Physical requirements

The Select printer requires an environment that accommodates its physical dimensions and weight.

The printer weighs between 21 and 26.5 pounds or 9.7 and 11.9 kilograms.

- **i** The surface holding the printer might also need to bear the weight of other equipment such as a PC and camera.

The dimensions are:

- Depth of 17.8 inches (54.1 cm) for Select models
- Depth of 24 inches (65 cm) for Select 2 models
- Width of 8.8 inches (22.2 cm)
- Height of 10 inches (25.4 cm)

The clearance required is:

- 3 inches (7.5 cm) on the left side of the printer, for access to the power switch and for ventilation.
- 3 inches (7.5 cm) in back of the printer for ventilation and for clearance for cables.
- 10.5 inches (26.7 cm) above the printer to allow the cover to open and to change supplies.

Environmental requirements

The Select printer requires the following environmental conditions for optimal operation:

- Operating relative humidity: 20% to 80% non-condensing
- Operating temperature range: 55° F to 95° F (13° C to 35° C)

If you store the Select printer, provide an environment with the following conditions:

- Storage relative humidity: 20% to 80% non-condensing
- Storage temperature range: 0° F to 100° F (-17.8° C to 37.8° C)

PC and software specifications

The Select printer must be used with a PC that runs the printer driver. The PC also runs a card creation application that captures and organizes the data to appear on each card.

To support the printing speed that the Select printer can deliver, the PC must meet the following requirements:

- Have a 233 MHz (or faster) Pentium MMX-, Pentium II-, Pentium III-, or Pentium IV-compatible processor
- Have at least 64 MB of memory (RAM)
- Have 50 MB or more of hard disk space available to store the printer driver and provide working space for preparing card data
- ❗ The PC resources, including processor speed, memory, and available hard disk space, can have a dramatic effect on card processing speed. For faster card printing, use a 450 MHz or faster processor with 128 MB or more of RAM.
- Have one of the following ports or connections:
 - An ECP parallel port (any operating system)
 - The port should be configured as an ECP port (using the PC's BIOS). If the existing parallel port is not ECP capable, obtain and install an ECP capable parallel port for printer use. For information on configuring the parallel port, "PC settings" on page C-1.
 - If your card creation application uses a security key, put the security key on a different parallel port, if available. The security key can be on a compatible-mode (IBM AT-mode) port. The printer data cable must remain on the ECP parallel port (usually LPT1).
 - You might receive "security key not found" messages, "parallel port data error" messages, or might notice that the card creation application operates slowly. If the security key requires a compatible-mode port, obtain and install a separate parallel port so you have a compatible-mode port for the security key and an ECP port for the printer.



- Some parallel communication devices use a cable with a plug that allows another device to be attached, so that two parallel devices are attached to one PC parallel port, known as a pass-through or piggy-back plug. The printer and printer driver cannot communicate reliably through such a plug. Install a second parallel port in the PC if needed.
- USB port (used with the Windows 2000, Windows Me, or Windows 98 operating system)
 - The PC might have more than one USB port, or USB devices already attached to the PC might provide USB ports to use.
- A network connection to support printer sharing or direct networking
- Have a CD-ROM drive to install the printer driver
- Have one of the following operating systems:
 - Windows Me (recommended)
 - Windows 98 Second Edition
- **i** The Windows 98 printer driver is designed to work on Windows Me or Windows 98 Second Edition. The printer driver can be installed and used on Windows 95 (OSR 2 recommended); however it is possible that unexpected results could occur. If you experience problems, consider upgrading the PC's operating system to Windows Me or 98. The printer cannot be connected to a PC running Windows 95 using a USB port.
 - Windows 2000 with service pack 2 (recommended)
 - Windows NT 4.0 with service pack 5 or higher
- **i** The Windows NT printer driver is designed to work on Windows NT with Service Pack 5 or 6. The printer driver can be installed and used on Windows NT with Service Pack 4; however it is possible that unexpected results could occur. If you experience problems, consider installing Service Pack 5 or 6. The printer cannot be connected to a PC running Windows NT using a USB port.

The PC must also have a card creation application that formats and prepares the card data. For the PC requirements of your card creation application, see the application's documentation.

ID system installation sequence

You might use this printer as part of an identification system (with a camera) or you might use it with existing data and applications. When you set up this printer along with other system components, install the printer driver after setting up the PC and before installing the card creation application and capture software and devices. Verify the success of each installation step before continuing.



User's Guide for ImageCard® Select™ and UltraGrafix® Select™ Printers

Install the printer

7

This section describes how to install and set up the Datacard® Select™ Class photo ID printer. It describes:

- Unpacking the printer
- Connecting the cables
- Installing the printer driver
- Printing sample cards

Unpacking the printer

Select a site that meets the requirements described in See “Before you install” on page 6-1. Unpack the printer, following these steps.

You need scissors or another cutting device to unpack the printer.

- ❗ Make sure you have one or more people to assist with unpacking the printer.

Unpack the printer

- 1 Place the shipping carton on a firm level surface.
- 2 Use a scissors to open the taped area on top of the shipping carton.
- 3 Open the shipping carton (step 1 in Figure 7-1).

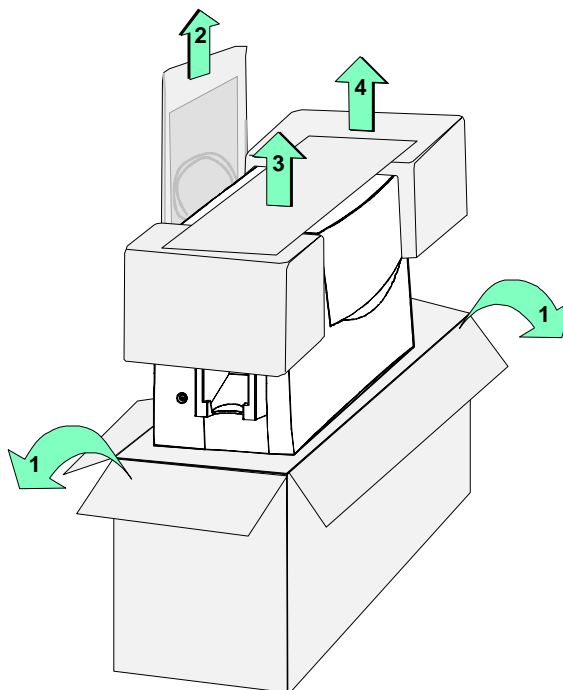

Figure 7-1: Unpack the printer

- 4 Remove the accessories bag (step 2 in Figure 7-1).
- ⚠ The printer weighs 21 to 26.5 (9.7. to 11.9 kg). Use proper lifting techniques. Make sure you have enough people to lift the printer comfortably.
- 5 Remove the Quick Install Chart from the carton (step 3 in Figure 7-1). The options included with the printer are checked on the chart.
- 6 Lift the printer from the carton (step 4 in Figure 7-1) and place it on a counter or other solid surface.



- 7 Slide the shipping supports off the ends of the printer. (The bottom shipping supports remain in the carton.)
- 8 Remove the printer from the plastic bag.
 - i** Save all packing material, including the plastic bag, shipping carton, shipping supports, and accessories bag.
- 9 Open the accessories bag and remove the contents. The accessories bag contains:
 - Power cable
 - Data cable, either a parallel port cable or a USB cable (not both)
 - Optional smart card serial cable(s)
 - Cleaning kit with printer cleaning card and replaceable cleaning sleeve
 - Continuous cleaning roller spindle
 - Warranty, declaration of conformity, and installation feedback report
 - User's Guide
 - Printer driver CD-ROM
 - Supplies kit if one was ordered with this printer
- 10 Make sure the card cartridge is securely seated in the printer. If needed, move it gently to seat it.



Who to call for assistance

If you work with a Datacard-authorized distributor or value-added reseller, contact your reseller for assistance. A value-added reseller provides the Select printer as part of an overall system.

If any contents of the box are missing, contact your distributor or reseller. If you purchased your printer directly from Datacard, contact Datacard. Make sure you have the serial number, located on the bottom of the printer, when you call.

Connecting cables

The printer requires a data cable and a power cable. The printer also requires one or more smart card serial cable(s) if a smart card module is installed. This section explains how to connect the printer cables.



The data cable can be a USB cable or a parallel port cable. Use only one data cable to connect the printer and PC.



If the printer is connected over a network using a print server, see the *SmartDriver Direct Network Installation and User Guide* for more information about connecting the printer.

Connect a parallel port data cable

- 1 Attach the parallel port cable to the ECP parallel port on the printer.
 - i** The parallel port cable must be a shielded, Type C, IEEE 1284 parallel port cable, up to a maximum of 6.5 feet or 2 meters long.

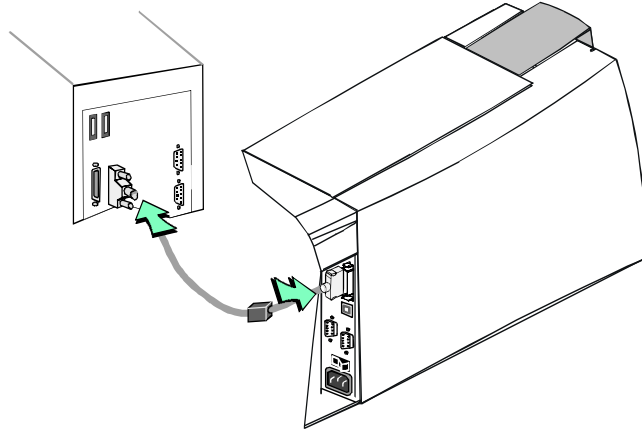

Figure 7-2: Connect the parallel port cable

- 2 Attach the other end of the cable to the parallel port on the PC (see [Figure 7-2](#)). Press the cable connector all the way onto the port, and then turn the posts to secure the cable to the PC.
 - i** Some parallel communication devices use a cable with a plug that allows another device to be attached, so that two parallel devices are attached to one PC parallel port, known as a pass-through or piggy-back plug. The printer and printer driver cannot communicate reliably through such a plug. Install an additional parallel port in the PC if needed.



Connect a USB data cable

- 1 Attach the flat end of the USB cable to the USB port on the PC (see Figure 7-3) or to a device attached to the PC through a USB port.

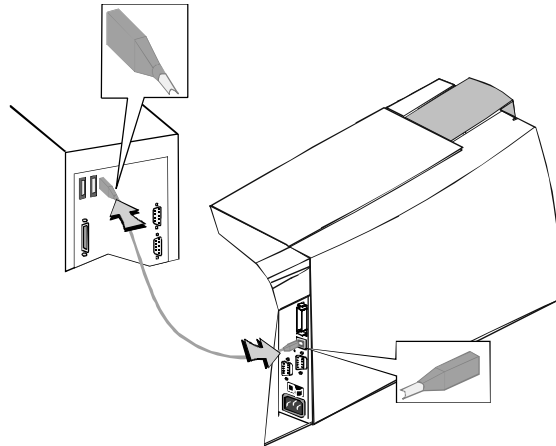

Figure 7-3: Connect the USB cable

- i** The USB cable must be a type CM 30V cable, up to a maximum of 6.5 feet or 2 meters long.
- 2 WAIT to attach the other end of the USB cable to the printer. You must connect the printer and the PC after the printer is powered on and ready. (Using this method, Windows will keep track of the printer if you move the cable to another physical USB port on the PC.)



Connect an optional smart card serial cable

- i** If the printer has a smart card module, the ports to use correspond to the module installed. If no smart card ports are installed in the printer, no cable is needed.
- 1 Connect the serial cable to the inside printer port (Figure 7-4) if a contact smart card module or a contact station is installed in the printer.
- i** The smart card serial cable must be a shielded DB9 serial cable, up to a maximum of 9.8 feet or 3 meters long.

- 2 Connect the serial cable to the outside printer port (Figure 7-4) if a contactless (☺) module is installed in the printer.

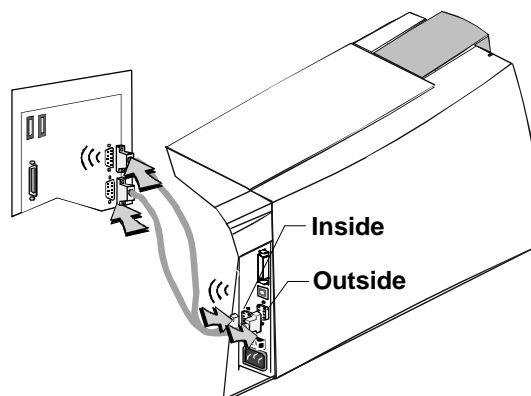

Figure 7-4: Connect the smart card serial cable

- 3 Use two smart card serial cables if both ports are installed on the printer (the smart card module contains both contactless (☺) (inside port) and contact (outside port) couplers).
- 4 Connect the other end of the smart card serial cable(s) to the appropriate serial port on the PC. See information for your smart card application for the correct PC port(s) to use.
- 5 Verify that serial port settings are correct. See "PC settings" on page C-1.



Connect the power cord

- 1 Attach the power cord to the power receptacle on the back of the printer (step 1 in Figure 7-5).

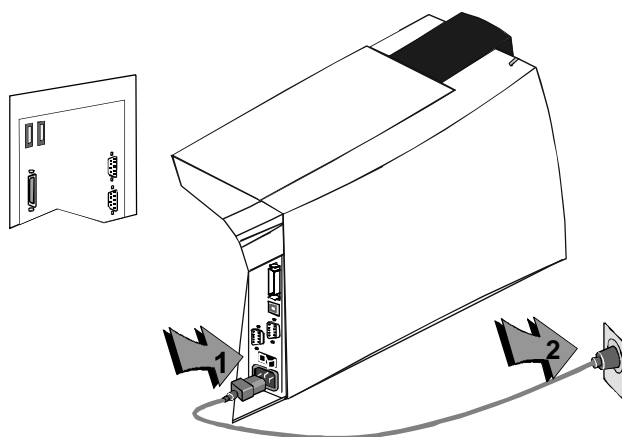

Figure 7-5: Connect the power cord



- 2 Plug the other end of the power cord into a single-phase, 3-wire grounded receptacle with 90-130V AC or 195-254V AC at 50 or 60 Hz (step 2 in Figure 7-5).
- i** The printer power supply automatically adjusts to the voltage of the input power.



Preparing the printer for driver installation

After connecting the printer and PC and before installing the driver, do the following:

- Load cards in the card cartridge. See “Loading cards” on page 2-2.
- Install the continuous cleaning roller in the printer. See “Replacing the cleaning roller sleeve” on page 4-2. There is no used sleeve to remove.
- Install the print ribbon. See “Loading the print ribbon” on page 2-4. When installing a new printer, there is no used ribbon to remove.
- Power on the printer and PC. See “Powering on the system” on page 2-6.
- If you are using a USB cable, connect the USB cable to the PC. (If you use a parallel cable, it was connected earlier.)

Installing the printer driver

The Select printer comes with a CD-ROM that contains the printer drivers for the supported Windows operating systems. The supported operating systems are:

- Windows Millennium Edition (Me) (recommended)
- Windows 98 Second Edition (SE)
- Windows 2000, with Service Pack 1 or 2 (recommended)
- Windows NT 4.0, with Service Pack 5 or 6

See “PC and software specifications” on page 6-4 for details on operating system support and limitations.

- i** If the PC does not have a CD-ROM drive, request diskettes from your service provider. (Service providers can obtain the driver as diskette images from the partner page.) You also can download the printer driver from the Datacard Web site, at www.datacard.com.
- i** If you have installed the printer driver and want to update to the most recent driver, delete the existing printer driver following the steps in the *e-Guide for ImageCard® Select™ and UltraGrafix® Select™ Printers*.
- i** Several other connection methods are available, including printer sharing over a network, installing two printers on parallel ports on a PC, and installing multiple printers to a PC using the USB port. See the *e-Guide for ImageCard® Select™ and UltraGrafix® Select™ Printers* (located in the e-Guide folder of the driver CD-

ROM, or through the e-Guide icon on the desktop) for information on these installation alternatives.

- i** You can also directly connect the printer to a network using the SmartDriver Direct Network Kit. See the Direct Network Guide for more information.

Select the procedure that applies to the operating system and type of port you use.

Operating system	Parallel	USB
Windows ME	"Install the printer driver to a parallel port" on page 7-8	"Install the printer driver to a USB port on Windows Me or 98" on page 7-11
Windows 98 SE	"Install the printer driver to a parallel port" on page 7-8	"Install the printer driver to a USB port on Windows Me or 98" on page 7-11
Windows NT	"Install the printer driver to a parallel port" on page 7-8	Not supported by the operating system.
Windows 2000	"Install the printer driver to a parallel port" on page 7-8	"Install the printer driver to a USB port on Windows 2000" on page 7-12

Install the printer driver to a parallel port

- 1 Close all applications. Do not close Windows.
- 2 Make sure the printer is connected to the PC.
- 3 Make sure the printer is powered on.
 - i** For Windows NT and Windows 2000, log in as the Administrator when you install the printer driver.
- 4 With Windows running, insert the CD-ROM in the PC's drive. The installation program starts automatically.
 - i** If the installation program does not start, make sure the CD-ROM is installed correctly.
 - If you are using diskettes, extract files to the PC's hard drive. The installation program starts automatically.





Figure 7-6: Driver installation program

- 5 Click Next in the first Printer Driver Setup dialog box.
 - i** The installation program automatically detects the operating system on your PC and selects the driver for that operating system. For Windows 2000, you will run a second program to complete installation.
- 6 Review the License Agreement and click Yes to continue.
 - i** If you used a different sequence to start installation, you might have a slightly different sequence of prompts.
- 7 The installation program displays a question asking whether you would like to view the Release Notes. Do one of the following:
 - Click Next to continue.
 - Click Yes and then Next to open the Release Notes in WordPad. Close the Release Notes when you have viewed the information.
 - For Windows 2000, clicking Next takes you to step 13.
- 8 Use the default name for the printer or enter a name of your choice. If you plan to share the printer across a network, “Select” must be part of the printer name. Click Next (not shown for Windows 2000).
- 9 Select the port to which the printer is connected and click Next (not shown for Windows 2000).
 - i** Select only one port for printer connection.
- 10 Select whether this printer should be the default printer (not shown for Windows 2000).
 - i** The small page size for cards might cause unexpected results with some applications if the Select printer is the default.
- 11 Click Next (not for Windows 2000).

- 12 The installation program copies files to the PC and updates entries (not for Windows 2000).
- 13 Install information if needed.
 - The installation program detects whether the Adobe Acrobat Reader program is installed on the PC. If it is not, the installation program asks if you want to install Acrobat Reader. Click Yes and the Next to install it.
 - If you are installing from the hard drive, you might see a message explaining that the *e-Guide for ImageCard® Select™ and UltraGrafix® Select™ Printers* and Acrobat Reader might not be available. Obtain the e-Guide (after installation) using one of these methods:
 - Download the latest release of the e-Guide from the Datacard web site at www.datacard.com.
 - Obtain the e-Guide from the E-Guide folder of the Printer driver CD-ROM. Using Windows Explorer, search for the Dssm.hlp file. Copy the e-Guide to the same folder as Dssm.hlp, so it is available when using help.
- 14 Follow the prompts to install Acrobat Reader.
- 15 The Restart Windows dialog box appears after a moment.
- 16 Click Finish to close the installation. The installation program will restart the PC when you click Finish (except on Windows 2000).
 - For Windows 2000, select Shut down from the Windows Start menu to restart Windows.
- 17 For Windows Me, Windows 98, and Windows NT, driver installation is complete. Go to “Changing required printer settings” on page 7-14.
 - ❗ On Windows Me and 98, the Add New Hardware wizard can appear when you restart Windows. Windows will associate the printer and driver, and close the Add New hardware wizard automatically.
- 18 For Windows 2000, the PC will display the “Found New Hardware” wizard after restarting. Follow the prompts to install the printer driver and restart the PC.
- 19 The operating system detects the printer and displays the Detected New Hardware wizard. Click Next.
- 20 On the next page of the wizard, make sure that “Search for a suitable driver for my device (recommended).” is selected. Click Next.
- 21 On the Locate Driver Files page, select one of the following:
 - “CD-ROM drives” if you are installing the printer driver from CD-ROM.
 - “Specify a location” if you are installing from the PC’s hard drive. Browse to locate the DsPnp.INF file.
- 22 Click Next to continue with installation.
- 23 On the Driver Files Search Results page, click Next.
- 24 The Digital Signature Not Found message appears. Click Yes to continue with installation.



- Security on the PC might be set to prevent installation without a digital signature. See Windows help for “digital signature” to change the security setting.
 - If installation is cancelled or cannot continue, see the *e-Guide for ImageCard® Select™ and UltraGrafix® Select™ Printers* steps to follow.
- 25 The installation program copies files to the PC and updates entries to enable the printer.
- 26 Restart the PC when the wizard prompts you.
- i** Leave the printer driver CD-ROM in the PC so you can print sample cards after you change required settings.



Install the printer driver to a USB port on Windows Me or 98

- 1 Close all applications. Do not close Windows.
- 2 Make sure printer is powered on.
- 3 Connect the printer to the PC using the USB data cable. The operating system detects the printer and displays the Add New Hardware wizard.
- 4 With Windows running, insert the CD-ROM in the PC's drive.
 - i** You might need to cancel the SmartDriver installation program if it starts automatically. The Add New Hardware wizard must start the installation program for USB installation.
 - If you are using diskettes, extract the files to the PC's hard drive.
- 5 Click Next. On the next page of the wizard, do one of the following:
 - Make sure that “Search for a suitable driver for my device (recommended).” is selected if you are installing from CD-ROM.
 - If you are installing from files on the hard drive, click “Specify the location of the driver.”
- 6 Click Next. Windows Me searches automatically.
 - For Windows 98, on the next page, select “Search for the best driver for your device” and “Specify a location.” Browse to find the DsPnp.inf file and click OK.
 - i** For some Windows Me and 98 PCs, Windows finds USBPrint.inf and installs USB printer support. If this occurs, the Add New Hardware wizard appears again. Repeat these steps, beginning with step 5.
- 7 The wizard loads the installation program.
- 8 Click Yes to accept the software license.
- 9 The installation program displays a question asking whether you would like to view the Release Notes. Do one of the following:

- Click Next to continue.
 - Click Yes and then Next to open the Release Notes in WordPad. Close the Release Notes when you have viewed the information.
- 10 The installation program copies files to the PC and updates entries to enable the printer.
- 11 Install information if needed.
- The installation program detects whether the Adobe Acrobat Reader program is installed on the PC. If it is not, the installation program asks if you want to install Acrobat Reader. Click Yes and the Next to install it.
 - If you install from the hard drive, you might see a message explaining that the *e-Guide for ImageCard® Select™ and UltraGrafix® Select™ Printers* and Acrobat Reader might not be available. Obtain the e-Guide (after installation) using one of these methods:
 - Download the latest release of the e-Guide from the Datacard web site at www.datacard.com.
 - Obtain the e-Guide from the E-Guide folder of the Printer driver CD-ROM. Using Windows Explorer, search for the Dssm.hlp file. Copy the e-Guide to the same folder as Dssm.hlp, so it is available when using help.
- If you are installing from the hard drive, the installation program for the Acrobat Reader might not be available. The e-Guide might also not be available. Follow the instructions on the message box to download these files if needed.
- 12 The Finish dialog box appears.
- 13 You must restart the PC before the driver can work with the printer. Click Finish to close the installation and restart the computer.

- i** The Windows Add New Hardware wizard closes on its own when you restart the PC.
- i** Leave the printer driver CD-ROM in the PC so you can print sample cards after you change required settings.



Install the printer driver to a USB port on Windows 2000

- i** Make sure you are logged in as the Administrator when you install the printer driver.
- 1 Close all applications. Do not close Windows.
 - 2 Make sure printer is powered on.
 - 3 Connect the printer to the PC using the USB data cable. The operating system detects the printer and displays the Found New Hardware Wizard.
 - 4 With Windows running, insert the CD-ROM in the PC's drive.



- i** You might need to cancel the Smart Driver Installation program if it starts automatically. The Found New Hardware wizard must start the installation program for USB installation.
- If you are using diskettes, extract the files to the PC's hard drive.
- 5 Click Next. On the next page of the wizard, make sure that "Search for a suitable driver for my device (recommended)." is selected.
 - 6 On the Locate Driver Files page, select one of the following:
 - "CD-ROM drives" if you are installing the printer driver from CD.
 - "Specify a location" if you are installing the printer driver from the PC's hard drive.
 - 7 Click Next to continue with installation.

If you specified a location, a dialog box in which you can browse appears. Browse to find the DsPnp.inf file. Click Open and OK.
 - 8 The wizard searches for the file to start installation. When it has found the DsPnp.inf file, click Next to continue.
 - 9 For Windows 2000, the Digital Signature Not Found message appears. Click Yes to continue with installation.
 - Security on the PC might be set to prevent installation without a digital signature. See Windows help for "digital signature" to change the security setting.
 - If installation is cancelled or cannot continue, see the *e-Guide for ImageCard® Select™ and UltraGrafix® Select™ Printers* steps to follow
 - 10 The installation program copies files to the PC and updates entries to enable the printer.
 - 11 A message appears telling you that installation is complete. It also reminds you of important tasks to perform. Click OK to restart the PC.
 - 12 The Found New Hardware Wizard closes and restarts the PC.
 - 13 Start the driver installation program to install information and desktop shortcuts.
 - a Locate the Setup.exe file in the base directory of the CD or in the folder containing driver files on the hard drive.
 - b Double-click the Setup.exe file to start the installation program.
 - 14 Install information if needed.
 - The installation program detects whether the Adobe Acrobat Reader program is installed on the PC. If it is not, the installation program asks if you want to install Acrobat Reader. Click Yes and the Next to install it.
 - If you install from the hard drive, you might see a message explaining that the *e-Guide for ImageCard® Select™ and UltraGrafix® Select™ Printers* and Acrobat Reader might not be available. Obtain the e-Guide (after installation) using one of these methods:
 - Download the latest release of the e-Guide from the Datacard web site at www.datacard.com.

- Obtain the e-Guide from the E-Guide folder of the Printer driver CD-ROM. Using Windows Explorer, search for the Dssm.hlp file. Copy the e-Guide to the same folder as Dssm.hlp, so it is available when using help.
- 15 The Finish dialog box appears.
- The dialog reminds you to run the Plug-and-Play driver installation. You have completed this step and do not need to run it again.
- i** Leave the printer driver CD-ROM in the PC so you can print sample cards after you change required settings.



Changing required printer settings

After installing the printer driver, there are several other tasks you might need to perform. The required tasks are:

- For Windows NT and 2000, change permissions to the printer for other users of the PC. See “PC settings” on page C-1 for steps to follow.
 - For Windows NT and 2000, make sure that users of the printer have permission to write files to the temp file location specified in the PC configuration. If the temp file location is not specified, the driver uses the root location, WINNT. See “PC settings” on page C-1 for steps to follow.
 - View and change settings in the Properties, Default Document Properties, or Printing Preferences dialog box. See “Working with printer settings and data” on page 3-2 for steps to follow.
- i** Open the Properties, Default Document Properties dialog box using the Printers window so the settings apply to all applications.
- Select whether to print on two sides (duplex printing). Select and apply this setting before making other changes.
 - Select the print ribbon type. This setting must be selected for Windows NT and Windows 2000, and is optional for Windows Me and Windows 98.
 - Select the topcoat (T) pattern for the front of the card, back of the card, or both.
 - If the printer has a magnetic stripe module, select the magnetic stripe coercivity and encoding format.
- For a directly networked printer, see the *SmartDriver Direct Network Installation and User Guide* for guidance on changing settings on the Admin PC and user PCs.
- i** At this time, you can also change optional settings, such as orientation and print margin.



Printing sample cards

The Select printer is shipped with cards that are printed in the factory. Files for these cards are also provided on the driver CD so you can print the same cards at your site.

Print sample cards

- 1 Begin with the printer powered on and connected to the PC, the printer driver installed, and Windows running.
 - ❗ Files for the sample card are located on the printer driver CD-ROM. If you print a sample card as part of installation, the CD-ROM should still be in the drive. If you print sample cards at some later time, insert the CD-ROM in the drive and cancel the installation program that automatically starts.
- 2 Change printer properties to print this card. See “Working with printer settings and data” on page 3-2 for steps to follow. The settings should be:
 - Print on Both Sides=No
 - Print margin=Edge to edge
 - Print topcoat pattern - front=Full card
- 3 From the Windows Start menu, select Programs and then Accessories.
- 4 From the Accessories list, select Imaging. The graphics application opens.
- 5 From the File menu, select Open.
- 6 In the Open dialog box, browse to D:\Support (where D is the driver letter for the CD-ROM drive) and select one of the following:
 - For ImageCard (color) printers, select the ImageCard test doc.tif file.
 - For UltraGrafix (monochrome) printers, select the UltraGrafix test doc.tif file.
- 7 The file opens.
- 8 From the File menu, select Print.
- 9 On the Print dialog box, choose the Select printer.
- 10 Select Options or Image Options. For “Print format,” select “Pixel to Pixel.” Click OK or Apply to change the setting.
- 11 Click OK or Print to print the card.
- 12 Compare the cards you printed with the cards shipped with the printer.
- 13 If the edges of your card are not printed, check the following:
 - The Print Margin setting should be Edge-to-Edge.
 - The Print Format settings should be Pixel to Pixel.
- 14 When you have printed the card and are satisfied that it matches the factory-printed card, close Imaging and remove the printer driver CD-ROM.

- 15 Use the card comparison to complete the Installation Report and e-mail or fax the report to Datacard.



Setup tips

Make sure that:

- The card cartridge is in place and contains cards.
- The data cable is connected to the parallel or USB port of the printer and the corresponding port of the PC. The ports used for each printer are the same as were installed. (For example, a printer cannot be installed through a parallel port and then used through a USB port.)
- If the PC has more than one port, the port to which the printer is assigned (such as LPT1) is the same as the port to which it is connected.
- The parallel port (if used) is configured as an ECP parallel port in the PC's BIOS. See "PC settings" on page C-1 for more information.
- The setting for the USB port (if used) are correct. See "PC settings" on page C-1 for more information.
- Supplies are installed and cartridges are loaded correctly. See "Using the printer" on page 2-1 for more information.
- The printer is ready to print. The status light on the printer should be steady green when you send a sample card. See "Status light" on page 2-7 for more information.
- Use the driver sample card, not a card from a card creation application, to verify that the printer and driver are working together.
- For a directly networked printer, see the *SmartDriver Direct Network Installation and User Guide* for guidance on setting up the printer and PC.

Optional settings

Depending on your card design and operating environment, you might change settings for optimal print quality. Print the sample cards before changing optional settings. The optional settings include:

- Set the print margin. The Select printer can print edge to edge, which is the same as a margin of 0. The default is a margin of 0.1 inch.
- Choose the cleaning interval in the printer driver. See "Working with printer settings and data" on page 3-2 for steps to follow. You can use the default interval of cleaning after every 250 cards, or select a longer or shorter interval. If you choose a value if 0, the printer driver will not prompt for cleaning. Make sure you clean the printer regularly, such as every time you change ribbon or each work day.



- Fine-tune black (K-panel) printing if you print bar codes or fine text. See the *e-Guide for ImageCard® Select™ and UltraGrafix® Select™ Printers* for steps to follow.
- Change color settings. After the card design is defined and other components of an identification system are set up, you might want to change color settings for maximum color quality. See the *e-Guide for ImageCard® Select™ and UltraGrafix® Select™ Printers* for steps to follow.
- For a directly networked printer, see the *SmartDriver Direct Network Installation and User Guide* for guidance on changing settings on the Admin PC and user PCs.

Additional settings that you might want to change include print registration and dithering for monochrome (K) printing. See the *e-Guide for ImageCard® Select™ and UltraGrafix® Select™ Printers* or contact your service provider for guidance.



User's Guide for ImageCard® Select™ and UltraGrafix® Select™ Printers

Safety and compliance

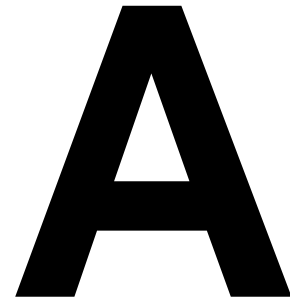

This appendix presents:

- Regulatory compliance information
- Safety information
- Trademark acknowledgments

Regulatory compliance

Notice for USA (FCC notice)

This equipment generates, uses, and can radiate radio frequency energy. If it is not installed and used in accordance with this instruction manual, it may interfere with radio communications. This equipment has been tested and found to be within the limits for Class A computing devices, pursuant to Subpart J of Part 15 of FCC rules, designed to provide reasonable protection against radio interference in a commercial environment. Operation of this equipment in a residential environment may possibly cause interference. In the event of interference, the user, at their own expense, will be required to take whatever measures are necessary to correct the problem.

Notice for Canada

This digital apparatus does not exceed the Class A limits for radio noise for digital apparatus set out in the Radio Interference Regulations of the Canadian Department of Communications.

Le présent appareil numérique n'émet pas de bruits radioélectriques dépassant les limites applicables aux appareils numériques de la classe A prescrites dans le Règlement sur le brouillage radioélectrique édicté par le ministère des Communications du Canada.

Notice for Europe

We hereby certify that the Datacard® Select™ Class photo ID printer complies with EMC Directive 89/336/EEC. This printer conforms to Class A of EN 55022. Operation of this equipment in a residential environment may possibly cause interference. In the event of interference, the user, at their own expense, will be required to take whatever measures are necessary to correct the problem.

Notice to Users of Printers Equipped with Contactless Smart Card Coupler

The contactless smart card coupler emits radio-frequency waves and must be used as installed and recommended by Datacard, the printer manufacturer. You may not modify the coupler or how it is used without the written permission of Datacard. You may not operate the printer after modifying the coupler or its method of operation.

Liability statement

This Datacard® product has been built to the high standards of Datacard Corporation (doing business as Datacard® Group). Please note and heed the WARNING and CAUTION labels that have been placed on the equipment for your safety. Please do not attempt to operate or repair this equipment without adequate training. Any use, operation or repair in contravention of this document is at your own risk. By acceptance of this system you hereby assume all liability consequent to your use or misuse of this equipment. Datacard Corporation assumes no liability for incidental, special or consequential damage of any kind. Equipment specifications, applications and options are subject to change at the sole discretion of Datacard Corporation without notice.

Safety

All Datacard® products are built to strict safety and reliability specifications in accordance with UL1950 and Canadian requirements, and the Low Voltage Directive 73/23/EEC. Therefore, safety issues pertaining to operation and repair of Datacard® equipment are primarily environmental and human interface.

The following basic safety tips are given to ensure safe installation, operation and maintenance of Datacard® equipment and are not to be considered as comprehensive on all matters of safety.

Safe environment

- Connect equipment to a grounded facility power source. Do not defeat or bypass the ground lead.
- Place the equipment on a stable surface (table) and ensure floors in work area are dry and non-slip. Insulated rubber floor mats are preferred.
- Know the location of equipment branch circuit interrupters or circuit breakers and how to turn them on and off in case of emergency.
- Know the location of fire extinguishers and how to use them. ABC type extinguishers may be used on electrical fires.
- Know local procedures for first aid and emergency assistance at the customer facility.
- Use adequate lighting at the equipment.
- Maintain the recommended range of temperature and humidity in equipment area.

Safe human interface

- Use proper lifting techniques when moving or installing the equipment.
- Use standard electrostatic discharge (ESD) precautions when working on or near electrical circuits.



User's Guide for ImageCard® Select™ and UltraGrafix® Select™ Printers

- Operate the printer with the cover closed.

Acknowledgments

Microsoft, Windows NT, and Windows are trademarks or registered trademarks of Microsoft Corporation.

Datacard, ImageCard, UltraGrafix, Express, Select, Tru Image, Advanced Imaging Technology, SmartDriver, ID Works, and ViaNet are trademarks or registered trademarks of Datacard Corporation.

All other trademarks are the property of their respective owners.



Supplies and cards

B

This appendix describes specifications, part numbers, and handling for supplies and components used with the Select printer with Advanced Imaging Technology™. It includes:

- Personalization supplies, including print ribbons
- Cards to print
- Cleaning supplies, including cleaning cards,, and the printhead cleaning pen
- Printer driver CD-ROM
- Printer components, including cables, additional supply cartridges, and the replaceable printhead cartridge

Personalization supplies

Print ribbon is used to personalize cards. This section describes Datacard®-recommended personalization supplies for the Select™ printer with Advanced Imaging Technology™ and how to store them.

- Use Datacard-recommended supplies in the Select printer.

Print ribbons

You can use the following Premium print ribbons in ImageCard Select printers with Advanced Imaging Technology™:

Ribbon type	Part number	Panel description	Colors Printed	One panel set prints:
YMCT	549081-105	Three colors and topcoat	Full color and topcoat	One side of a card
YMCKT	549081-104	Three colors, true black, and topcoat	Full color, true black, and topcoat	One side of a card
YMCKTKT	549081-106	Three colors, true black, topcoat, true black, and topcoat	Full color, true black, and topcoat	Front—full color, true black & topcoat; Back—true black & topcoat

You can use the following single-color (monochrome) print ribbons in ImageCard and UltraGrafix printers:

- i** If you use a K ribbon with a color other than black, see “Changing the type of print ribbon” in the *e-Guide for ImageCard® Select™ and UltraGrafix® Select™ Printers*.

Ribbon type	Part number	Panel description	Colors	One panel set prints:
KT	806124-109	True black and topcoat	Black	One side of card
K black	596230-001	Continuous black	Black	Not applicable
K dark blue [†]	596230-002	Continuous dark blue	Blue	Not applicable
K white [#]	596230-003	Continuous white	White	Not applicable
K red [†]	596230-004	Continuous red	Red	Not applicable
K green	596230-006	Continuous green	Green	Not applicable
K burgundy	596230-012	Continuous burgundy	Burgundy	Not applicable
K teal	596230-014	Continuous teal	Teal	Not applicable
K purple	596230-015	Continuous purple panel	Purple	Not applicable
K warm red	596230-016	Continuous warm red panel	Warm red	Not applicable
K silver	596230-007	Continuous silver	Silver	Not applicable
K scratch-off	548237-001	Continuous scratch-off panel	Scratch-off	Not applicable

[#]. Print ribbon is larger than printer capacity. Remove 7 yards (6.5 m) of ribbon before loading this roll in the printer.

[†]. Set ribbon type to K; do not use the Always Autodetect setting.

- i** When you use a monochrome print ribbon, use a printhead cartridge designed for monochrome printing for optimum results. See “Printhead cartridge” on page B-9.
- i** If you change the type of ribbon you use, be sure to make the appropriate changes to the Select printer driver. See “Changing the type of print ribbon” in the *e-Guide for ImageCard® Select™ and UltraGrafix® Select™ Printers*

Supply roll storage

Follow these guidelines when storing supply rolls:

- The print ribbon quality for about a year. For optimal card quality, purchase and store quantities that you can use up in less than a year.
- The print ribbon card stock might require secure storage and tracking. Follow your policy for storing and tracking the supplies used to make cards.
- Select a location away from direct sunlight, with a temperature between 55° F and 80° F or between 13° C and 27° C. A humidity range from 20% to 80% (non-condensing) is recommended.



User's Guide for ImageCard® Select™ and UltraGrafix® Select™ Printers

- Supply rolls should be at room temperature when they are installed in the printer and used. If supplies are stored in a cooler environment than the printer, allow supplies to reach room temperature before using.

Cards

This section describes specifications and quality guidelines for card stock to use with the Select printer. It also describes the environmental specifications for storage of card stock.

Card specifications

For best results with the Select printer, use high-quality card stock that meets the specifications and recommendations described in this section.

Card size

Use CR-80 size cards with the following nominal dimensions:

Length	3.37 inches	85.60 mm
Width	2.125 inches	53.98 mm
Thickness with smart card chip	0.020 to 0.030 inches	0.500 to 0.760 mm
Thickness (all other cards)	0.020 to 0.050 inches	0.500 to 1.27 mm

- ❗ Actual card thickness can vary by up to ten percent from the sizes listed. Smart card chips can be raised slightly from the printing surface.

Card bow must be less than the thickness of the card.



Figure B-1: Excessive card bow

Card material

Use cards made of the following types of material:

- Glossy PVC surface, either 100% PVC cards or composite cards with a PVC surface.
- Cards with a magnetic stripe on one side of the card.

- Cards with a smart card chip on the top of the card. Depending on the module installed in the printer, contact-type, contactless, or both types of smart card chips can be programmed.
- ❗ Embossed cards cannot be printed with the Select printer.

StickICards

Datacard brand StickICards, part number 597640-001, can be used. StickICards are used to make personalized cards that can be adhered to proximity cards when the card surface is not flat enough to print.

The printing surface of the StickICard (white side) meets the material requirements for use in the printer. When using StickICards, the printer's card tracks must be cleaned to remove any adhesive residue. The printhead cleaning pen or an isopropyl alcohol swab will remove the residue.

New cards preferred

The Select printer is designed to print on new card stock. If you print on cards twice, be careful to avoid getting dirt, fingerprints, or other contamination on cards before the second printing. Printing on cards that have been issued might introduce substances that interfere with card printing or damage the printer. See to address card appearance problems with pre-printed cards.

- ❗ If a previously printed card has a protective "T" panel, the card cannot be printed a second time.

Pre-punched cards

You can use prepunched cards with the Select printer. Figure B-2 shows where punched areas are not allowed.

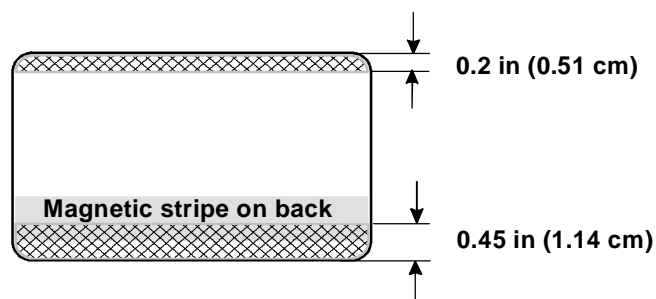

Figure B-2: Pre-punched card block-out areas

The dimensions show how far from the edge any punched areas must be (dimensions include any tolerance):

- The cards cannot have a punched area closer than 0.2 in (0.51 cm) from the left-hand edge (as loaded in the card cartridge).

- The cards cannot have a punched area closer than 0.45 in (1.14 cm) from the right edge (as loaded in the card cartridge).
- If the card has a magnetic stripe, the card cannot be punched anywhere in the stripe.

Card quality guidelines

Your cards must meet the following card quality guidelines for the Select printer to print high quality graphics on them successfully.

Card surface

- The card surface must be free of irregularities such as particles embedded in the surface.
- The card surface must be smooth and even. Surface irregularities can cause loss of contact, resulting in printing voids.
- The printing surface must be glossy. It cannot have a matte finish (see other sections in this appendix for more information).
- Card edges must be free of raised burrs which can cause unprinted areas on cards. This is especially true when printing Edge-to-Edge. Burrs along card edge will result in printing voids.

Card handling

These guidelines apply to unprinted cards. Any debris or particles on an unprinted card's surface can reduce print quality and damage the printhead. Grease or oils, such as oils from your fingers, also reduce print quality.

- Keep cards completely clean.
- Do not touch the print surface of a card with your fingers or hands.
- Do not use a rubber band to bind blank cards together.
- If you drop a card on the floor, do not insert it into the Select printer.

Card storage

These guidelines apply to both printed and unprinted cards.

- Cards must be stacked so that they will not shift and rub against each other.
- When storing cards, make sure that no two cards contain images or blocks of color that will come in contact with each other.
- Make sure that the magnetic stripe on one card does not come in contact with the magnetic stripe on another card.
- Make sure that cards with magnetic stripes are stored away from magnets and other magnetic objects.

Card storage specifications

The cards should be stored in a cool, dry, and dark place. Excessive light can cause yellowing of cards on exposed edges. Keep cards in their original packaging.

Cards should be at room temperature when they are installed in the printer and used. If cards are stored in a cooler environment than the printer, allow them to reach room temperature before using.

Cleaning supplies

The Select printer uses the following cleaning supplies.

- cleaning cards
- Replaceable cleaning sleeves
- Printhead cleaning pen

Printer cleaning card

Use a printer cleaning card to remove particles left by printing supplies inside the Select printer. Use a printer cleaning card at the interval you set, such as every 250 cards (see “Working with printer settings and data” on page 3-2).

Printer cleaning cards are sold in packages of 10. The package part number is 557297-001. Printer cleaning cards are also sold as part of cleaning kits, described below.

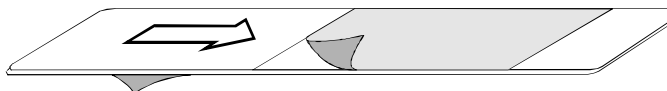

Figure B-3: Printer cleaning card

- ❗ If the printer does not have a magnetic strip module, you can use cleaning card part number 548714-001.

Replaceable cleaning sleeve

Use a replaceable cleaning sleeve on the continuous cleaning roller. Change the replaceable cleaning sleeve before you run a printer cleaning card.

The replaceable cleaning sleeve is sold in packages of 5. The package part number is 549716-001. The replaceable cleaning sleeve is also available as part of a cleaning kit.



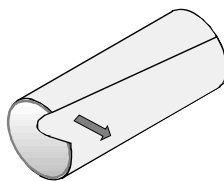

Figure B-4: Replaceable cleaning sleeve

Cleaning kits

Cleaning kits include 5 printer cleaning cards and 5 replaceable cleaning sleeves. The following cleaning kits are available:

Printer features	Part number
For printers with magnetic stripe modules	549718-001
For printers without magnetic stripe modules	549717-001

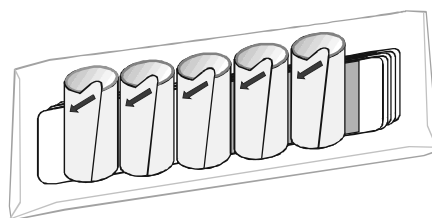
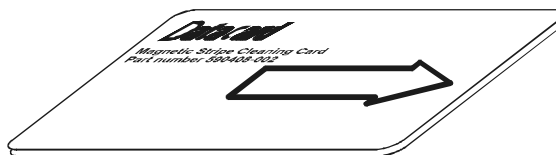

Figure B-5: Cleaning Kit

Magnetic stripe cleaning card

Use the magnetic stripe cleaning card if the printer has a magnetic stripe module. The card is part number 590408-002.



⚠ Do not use the magnetic stripe cleaning card more than once every 2000 cards or excessive wear can result.

Cleaning pen

To maintain print quality and prolong the life of the printhead and other parts, use a cleaning pen. The cleaning pen is part number 557492-001. Each pen can be used eight times.

Printer driver CD-ROM

The Select printer drivers are delivered on a CD-ROM. The CD-ROM also contains associated files and utilities you might need.

The following table lists the contents of the CD-ROM, the path, and the purpose of the program, file, or utility:

	Path	Purpose
Printer driver for Windows NT	D:\NT\SETUP.EXE [#]	Custom installation for Windows NT 4.0 and Windows 2000
Printer driver for Windows 2000	D:\2000\SELECT2K.INF [#]	Installation for Windows 2000 that meets Microsoft Plug-and-Play requirements
Printer driver for Windows Me and 98	D:\98\SETUP.EXE [#]	Custom installation for Windows Me and Windows 98
e-Guide	D:\e-Guide\ Sel-e-Guide.pdf [#]	e-Guide file, which contains error recovery procedures linked to help. Copy to C:\WINDOWS\SYSTEM or C:\WINNT\System32 if it was not installed
Adobe Acrobat Reader installation	D:\Adobe\ AR500ENU.EXE [#]	Installation program for Adobe Acrobat Reader, Version 5.00. The Reader (version 3 or higher) is required to view the e-Guide, part of the help system.
SmartDriver Diagnostics Utility	D:\Support\Diagnostics\ SETUP.EXE [#]	Installation program for the SmartDriver Diagnostics Utility, used to identify or fix printer problems
Cleanup Utility	D:\Support\Diagnostics\ CLEANUP.EXE [#]	Installation program for the Cleanup Utility, which is used after removing a version 1.x or 2.x driver.

[#]. Where D is the drive letter of the CD-ROM drive



	Path	Purpose
Support files	D:\Support\ ImageCard Test Doc.tif D:\Support\ UltraGrafix Test doc.tif D:\Support\color.prn D:\Support\mono.prn [#]	Sample card files and files used at the direction of service for troubleshooting.
SmartDriver SDK	D:\Support\SDK\ SmartDriver SDK.exe	Self-extracting file for the SmartDriver SDK which is used to write applications that work with the printer.

[#]. Where D is the drive letter of the CD-ROM drive

The printer drivers are updated from time to time to provide optimal functionality. You can obtain the most recent printer driver for the PC operating system you use from the Datacard Web site at www.datacard.com. You also can request the newest release of the printer driver on CD-ROM. The part number changes with each release. The e-Guide is also updated from time to time and can be downloaded from the Datacard Web site at www.datacard.com.

Printer components

The Select printer has a replaceable printhead cartridge. In addition, you can order additional or replacement parts for the printer. This section describes the printer parts you can order.

Printhead cartridge

The Select printer has a replaceable printhead. The printhead is subject to wear and has a direct impact on print quality.

Select the printhead to order based on the printer series. The following printheads are available.

Printer series	Printhead type	Printhead type label	Part Number
ImageCard	Full Color	Three colors	549285-999
UltraGrafix	Monochrome	All black	549284-999

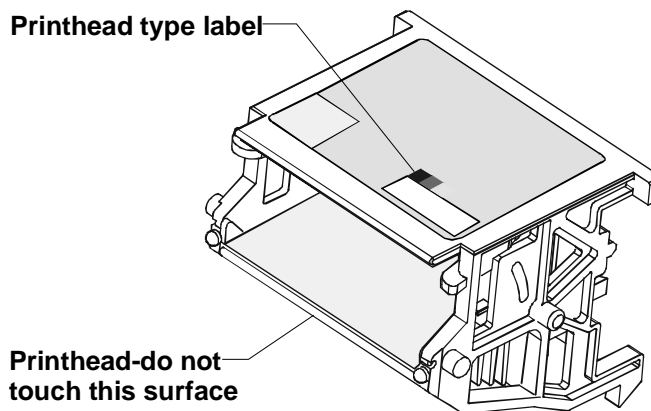

Figure B-6: Select replaceable printhead cartridge

⚠ Do not touch the printing edge of the printhead in the printhead cartridge. If you do, clean it. See “Cleaning the printhead” on page 4-9.

Keep a replacement printhead in stock so it is available when you need it.

Data cable

The Select printer uses a data cable to connect the printer to the PC.

Parallel port cable

The parallel port cable must be a shielded, Type C, IEEE 1284 parallel port cable, up to 2 meters long, maximum. The part number is 550093-001.



Figure B-7: Parallel port cable

USB cable

The USB cable must be a Type CM 30V, up to a maximum of 2 meters long. The part number is 807614-001.



Figure B-8: USB cable



Power cord

The Select printer uses one of the following power cords:

- U.S. power cable (part number 556766-010)

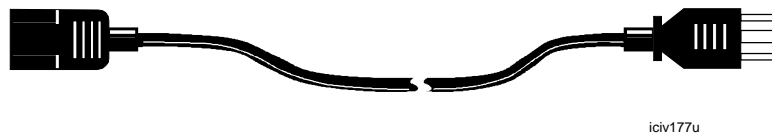

Figure B-9: U.S. power cable

- European power cable (part number 806842-001)
- Australian power cable (part number 806842-002)
- United Kingdom power cable (part number 806842-003)
- Danish power cable (part number 806842-004)
- Indian power cable (part number 806842-005)
- Israeli power cable (part number 806842-006)
- Italian power cable (part number 806842-007)
- Swiss power cable (part number 806842-008)
- Japanese power cable (part number 806842-009)

Smart card serial cable



If the Select printer has one or more smart card modules, it uses the smart card serial cable to connect the smart card port and the PC. The smart card serial cable is part number 805815-001.

- **i** The smart card serial cable must be a shielded DB9 serial cable, up to 3 meters long maximum.

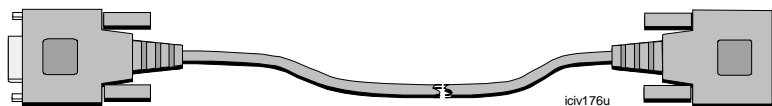

Figure B-10: Smart card serial cable

Print ribbon cartridge

The print ribbong cartridge is part number 555545-998.

- ❗ Be sure to change the print ribbon setting in the printer driver when you change the type of print ribbon.

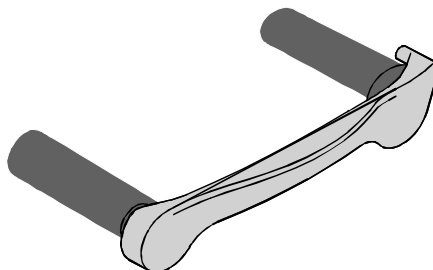

Figure B-11: Print ribbon cartridge

Card cartridge

The card cartridge is part number 549311-999.

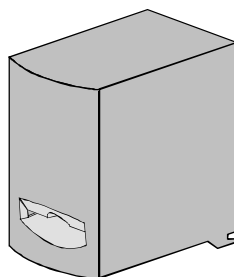

Figure B-12: Card cartidge

Replacement keys for optional lock

The optional lock for the card cartridge uses one of five replacement keys.

The part numbers for the five replacement keys are:

Key Code	Part Number
104	551029-104
114	551029-114
122	551029-122
131	551029-131
134	551029-134



Cleaning roller spindle

The Cleaning roller spindle holds the replaceable cleaning sleeve. The part number is 549130-001.

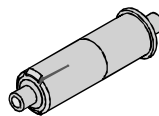

Figure B-13: Cleaning roller spindle

Related publications

This section describes publications for the Select printer with Advanced Imaging Technology™.

- User's Guide for ImageCard® Select™ and UltraGrafix® Select™ Printers, Part Number 539123-001

This manual is part of the SmartDriver Software Developer's Kit (557214-001) and provides basic information about using the printer and driver, and how to care for the printer. The index of this manual includes entries for both the User's Guide and the e-Guide.
- Quick Install Chart for the ImageCard® Select™ and UltraGrafix® Select™ Printer, Part Number 539143-001

This sheet provides a streamlined installation process for typical one-printer-to-a-PC installation. It also shows supplies and equipment shipped with the printer.
- e-Guide for ImageCard® Select™ and UltraGrafix® Select™ Printers, Part Number 539124-001

The online e-Guide provides information about how to fix problems. It also provides advanced information, such as how to connect two printers to one PC.
- SmartDriver API Software Developer's Manual, Part Number 526720-001

This manual is part of the SmartDriver Software Developer's Kit (557214-001) and provides information to programmers who are developing applications to print to Datacard printers, including the Select printer. This manual is available only as part of the kit.
- ImageCard Select with Advanced Imaging Technology™ Service Manual, Part Number 539142-001

This manual is delivered on CD-ROM and provides information to service providers who maintain or repair the Select printer.
- SmartDriver Direct Network Guide, Part Number 539171-001.

This manual is part of the Direct Network Kit (550749-001). Contact your service provider to obtain a copy of the guide or contact your Datacard reseller to obtain a Direct Network Kit.



PC settings

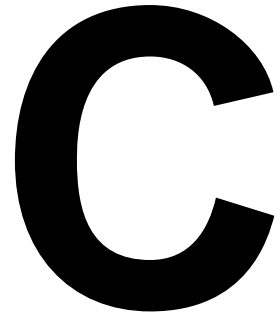

This appendix provides information about the PC on which the printer driver for the Select printer with Advanced Imaging Technology™ is installed. It describes:

- Configuring the ECP parallel port
- Removing a printer from the Device Manager
- Setting port values
- Setting printer permissions (Windows NT only)
- Configuring the optional smart card serial port

This appendix includes a section for settings that are handled the same way in all operating systems and also includes sections for each PC operating system supported by the printer driver.

PC settings for all operating systems

This section describes how to configure the ECP parallel port.

Configuring the ECP parallel port

For most PCs, the parallel port is configured as an ECP parallel port in the PC's BIOS. The following applies to some PCs and to the Windows 2000, Windows NT, Windows Me, and Windows 98 operating systems.

- ❗ See the information that accompanies your PC for details about changing the BIOS settings.

Configure the ECP parallel port

- 1 Close all open applications.
- 2 Reboot the PC. Observe the screen for instructions on entering Setup.
- 3 Enter Setup and follow the instructions that display early in the reboot sequence. The setup screen will appear.
- 4 In Setup, check to see that the Parallel Port Mode field is set to ECP. If it is not, set it to ECP.

- ❗ If the PC has more than one parallel port, make sure you check the setting for the parallel port to which the printer is attached (LPT1 or LPT2).

- ❗ An ECP port is required for the printer to operate at its maximum processing speed. The printer will operate in compatible or IBM AT mode; however, the printer might not operate as fast.

- 5 Save the setting and exit Setup, following the instructions in the setup screen. Continue with the "Set port values" procedure for your operating system.



Set up two ECP parallel ports

- 1 Follow the instructions provided with the port to install it and set the jumpers. Record the jumper settings.
- ❗ The jumper settings must match the settings you choose in the Resources tab.
- 2 Right-click on the My Computer icon on the desktop and then select Properties from the popup menu. The System Properties dialog box appears.
 - 3 Select the Device Manager tab to view a list of devices.
 - 4 Select "View devices by type" if needed.



- 5 Click the + next to Ports (COM and LPT) to display the port entries. Usually the second installed port is LPT2.
- 6 Click Printer Port (LPT2), or other entry for the installed port, and then select the Properties button. The Printer Port (LPT2) Properties dialog box appears (see Figure C-1).
- 7 Click the Resources tab.
 - Make sure that “Use automatic settings” is not selected.
 - The “Conflicting device list” should show No conflicts.
 - If you are using a DMA channel for the second printer, the Resources settings list should show Direct Memory Access and its channel setting.

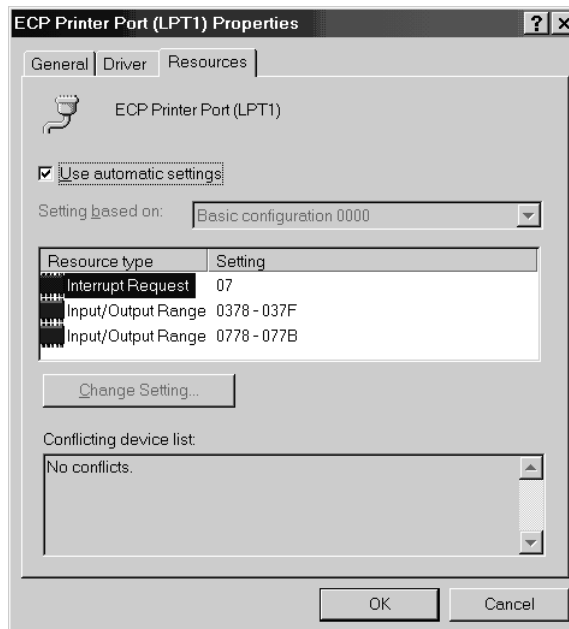

Figure C-1: Printer Port (LPT) Properties dialog box

If the Resources tab shows conflicts, select another configuration or change the settings for the port, following port instructions.

- 8 Click OK on the Printer Port (LPT2) Properties dialog box and on the System Properties dialog box to save settings and close the dialog boxes.
- i** If you install the second parallel port and receive Windows errors, or if the printer does not print reliably (without displaying errors), the port might have an unresolved hardware conflict. Contact the port manufacturer or the PC manufacturer for assistance.



Set up a Universal Serial Bus (US) port

- 1 Right-click on the My Computer icon on the desktop and then select Properties from the popup menu. The System Properties dialog box appears.
- 2 Select the Device Manager tab to view a list of devices. (On Windows 2000, select the Hardware tab and then click the Device Manager button.)
- 3 Select “View devices by type” if needed.
- 4 Click the + next to Universal Serial Bus controllers to display the USB port controllers.
- 5 Click USB Root Hub, and then select the Properties button. (On Windows 2000, right-click USB Root Hub and then select Properties from the pop-up menu.) The USB Root Hub Properties dialog box appears.
- 6 Make sure that “Disable in this hardware profile” is not selected. Click OK to close the dialog box.
- 7 Click the other entry, which includes the name of the installed USB device and ends with “Host Controller”, and then select the Properties button. (On Windows 2000, right-click USB Host Controller and then select Properties from the pop-up menu.) The Properties dialog box appears.
 - Make sure that “Disable in this hardware profile” is not selected.
 - Click the Resources tab (see Figure C-2). The “Conflicting device list” should show No conflicts.

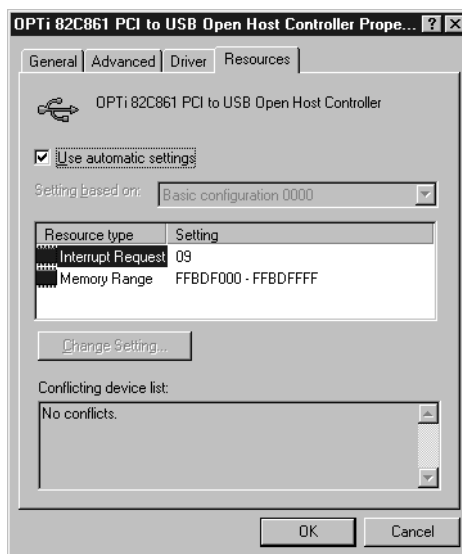

Figure C-2: USB Root Hub Properties dialog box

If the Resources tab shows conflicts, select another configuration or change the settings for the port, following port instructions.

- 8 Click OK on the Properties dialog box and on the System Properties dialog box to save settings and close the dialog boxes.



Remove a device from the Device Manager

Remove a device from the Device Manager if the Add/Detect New Hardware wizard was cancelled (or another installation problem occurred), or you want to reinstall the printer driver.

- 1 Disconnect the printer from the PC.
- 2 If the printer driver was installed, make sure the printer driver has been deleted and that you have rebooted the PC after deletion.
- 3 Select Start from the Windows taskbar.
- 4 From the Windows Start menu, select Settings, and then Control Panel. The Control Panel appears.
- 5 Double-click the System icon to open it. The System dialog box opens.
- 6 Open the Device Manager.
 - On Windows ME, Windows 98, and Windows NT, click the Device Manager tab.
 - On Windows 2000, click the Hardware tab. Click the Device Manager button.
- 7 Make sure “View devices by type” is selected.
 - On Windows 2000, select “View hidden devices” from the View menu.
- 8 Locate the device to delete. The device might be called “Unknown device” or “Select Class with AIT”. If neither of these types of devices are displayed, go to step 10.
 - On Windows ME, Windows 98, and Windows NT, click on the device name or icon to select it, and then click the Remove button.
 - On Windows 2000, click on the device name to select it, and then right-click to display a pop-up menu. Select Remove from the pop-up menu.
- 9 Click Yes or OK to confirm removal of the device.
- 10 Click OK to close the Device Manager. Close any other windows.



PC settings for Windows 2000 and NT 4.0

This section describes the following settings for PCs running Windows 2000 and NT 4.0.

- Setting parallel port values
- Setting USB port values

- Setting printer permissions
- Setting serial port values

Setting parallel port values

Port values include the port to which the printer is assigned, the communication mode for the port, and printer spooling.

Set parallel port values for Windows 2000 and NT 4.0

- 1 From the Windows NT taskbar select Start, then Settings, and then Printers. The Printers window appears.
- 2 Highlight the Select printer driver icon by clicking on it once.
- 3 From the menu bar, select File and then Properties. The Properties window for the Select printer driver appears.
- 4 Select the Ports tab.
- 5 Make sure the correct port (usually LPT1) is selected in the Port list. "Select" should appear in the Printer column for the checked port.
- 6 Make sure that Enable Bidirectional Support is checked.
- 7 Select OK to save the settings and close the Properties window.
- 8 Close the Printers window.
- 9 If you change the port to which the PC prints, power off the printer, shut down the PC, and restart both of them before printing cards.



Setting printer permissions

If the PC to which the printer is attached has other users, set permissions that:

- Allow users to use all features of the printer and driver, including messages. (Messages inform users when they need to change the ribbon, load cards, and fix problems.)
- Prevent any access to the printer by unauthorized users.

Set printer permissions for Windows 2000

- 1 From the Windows taskbar select Start, then Settings, and then Printers. The Printers window appears.
- 2 Highlight the Select printer driver icon by clicking on it once.
- 3 From the menu bar, select File and then Properties. The Properties window for the Select printer appears.



- 4 Select the Security tab.
- 5 Review the Names list. If the names for which you want to specify permissions do not appear in the list, add the names.
 - a Select the Add button to open the Select Users and Groups dialog box.
 - b Click on the name and click Add. Repeat for each name to add.
 - c When done adding names, click OK. The Select Users and Groups dialog box closes.
- 6 In the Names list, select the name for which you want to specify permissions.
- 7 From the Permissions list, select the access:
 - For a local user of a local printer and for a user of a directly networked printer
 - To enable printing, select Allow for Print, Manage Printers, and Manage Documents.
 - For a user who should not print on the Select printer, select Deny for all permissions.
 -  Single permissions, such as the Print permission, are not supported.
 - For a user of a shared printer:
 - For a user of the Select printer on the PC connected to the printer, select Allow for Print, Manage Printers, and Manage Documents. The user will be able to see all messages. The user will also be able to perform other actions, such as deleting the printer driver. (Single permissions, such as the Print permission, are not supported for local users of the printer driver.)
 - For a user who should not print on the Select printer, select Deny for all permissions.
 - For a user connected through a network using Printer Sharing, select Allow only for the Print permission. (Select Deny for Manage Printers and Manage Documents.)
- 8 Select Apply to save the change. Save changes for each name.
- 9 Repeat steps 6 through 8 to add other users or groups.
- 10 Select OK to close the Properties dialog box.



Set printer permissions for Windows NT

- 1 From the Windows taskbar select Start, then Settings, and then Printers. The Printers window appears.
- 2 Highlight the Select printer driver icon by clicking on it once.
- 3 From the menu bar, select File and then Properties. The Properties window for the Select printer appears.
- 4 Select the Security tab.

- 5 Click the Permissions button to open the Printer Permissions dialog box.
- 6 Select the Add button to open the Add Users and Groups dialog box.
- 7 Select the Show Users button.
- 8 Select the name of the user (or group) to add to the printer and click the Add button.
- 9 From the Type of Access list, select the access:
 - For a local user of a local printer or for a user of a directly networked printer:
 - For a user connected to a directly networked printer, select Full Control.
 - For a user who should not print on the Select printer, select No Access.
 -  Other user permissions, such as the Print permission, are not supported
 - For a user of a shared printer:
 - For a user of the Select printer on the PC connected to the printer, select Full Control. The user will be able to see all messages. The user will also be able to perform other actions, such as deleting the printer driver. (Other user permissions, such as the Print permission, are not supported for local users of the printer driver.)
 - For a user who should not print on the Select printer, select No Access.
 - For a user connected through a network using Printer Sharing, select Print permission.
- 10 Select OK to save the change and close the Add Users and Groups window.
- 11 Repeat steps 6 through 10 to add other users or groups.
- 12 Select OK to save the changes and close the Printer Permissions window.
- 13 Select OK to close the Properties dialog box.



Setting a smart card serial port—Windows 2000 and NT



If you use a smart card application, you connect the PC to the serial port on the Select printer. The PC should be set to match the printer serial port settings. This section describes how to set the PC serial port in the Windows 2000 or NT 4.0 operating system. These settings apply to ports for both a contact smart card module and a contactless smart card module. If you use a contact station with the printer, see the information for the contact station for port settings.

Set the serial port on Windows 2000 and NT

- 1 From the Start menu, select Settings and then Control Panel.
- 2 From the Control Panel, select Ports.



- 3 From the Ports dialog box, select the port, such as COM1 or COM2 (Figure C-3).

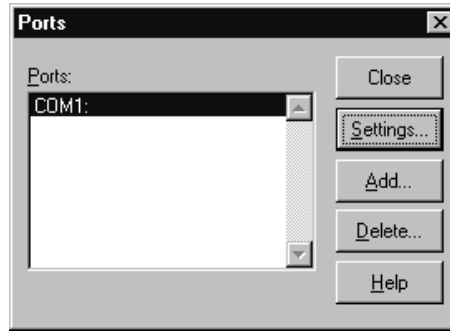

Figure C-3: Ports dialog box

- 4 Select the Settings button to display the port settings.
- i** If the PC has more than one serial port, make sure you view the settings for the serial port to which the printer is attached.

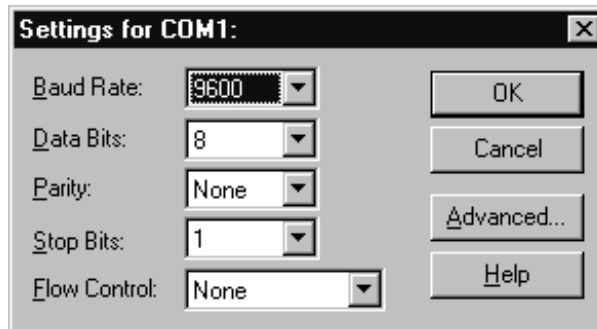

Figure C-4: Settings dialog box

- 5 Select the following settings:

Setting	Value
Baud rate	9600
Data bits	8
Parity	None
Stop bits	1
Flow control	None

- 6 When the settings are correct, click OK to save settings and close the dialog box.



PC settings for Windows Me and 98

This section describes the following settings for PCs running Windows Me and 98.

- Setting parallel port values
- Setting USB port values
- Setting serial port values

Setting parallel port values

Parallel port values include the port to which the printer is assigned, the communication mode for the port, and printer spooling.

Verify port assignment and settings

- 1 From the Windows taskbar select Start, then Settings, and then Printers. The Printers window appears.
- 2 Highlight the Select printer driver icon by clicking on it once.
- 3 From the menu bar, select File and then Properties. The Properties window for the Select printer driver appears.
- 4 Select the Details tab and view the port in the Print to the Following Port list.
Make sure this is the ECP parallel port.

 If you need to move the printer to another port, delete the existing printer driver and install the printer to the correct port.

- 5 Click Spool Settings to display the Spool Settings dialog.
- 6 Make sure that Enable Bidirectional Support is checked. Also make sure that Spool Print Jobs so Program Finishes Printing Faster is checked.
- 7 Select OK to save the settings and close the Spool Settings dialog.
- 8 Select OK to save the settings and close the Properties dialog box.
- 9 Close the Printers window.



Verify communication mode

- 1 From the Windows taskbar select Start, then Settings, and then Control Panel. The Control Panel window appears.
- 2 Double-click the System icon. The System Properties dialog box appears.
- 3 Select the Device Manager tab.
- 4 Make sure View Devices by Type is selected.



- 5 Click the Plus sign + next to Ports (COM & LPT) to show the available ports. The list should include an entry such as "ECP Printer port (LPT1)."
- 6 Click the entry for the port to which the printer is assigned (such as LPT1 or LPT2).
- 7 Select the Properties button to display the Properties dialog box.
- 8 Select the Driver tab, and then select the Update Driver button to display the Select Device dialog box.
- 9 Make sure Show all devices is selected.
- 10 In the Manufacturers list, select (Standard port types). In the Models list, select ECP Printer Port, if available.
- 11 Select OK or Close on each window to select the choice and close the window. If the Version Conflict dialog box appears, select Yes to keep the existing version.
- 12 Select OK to close the System dialog box and make the changes take effect.



Setting a smart card serial port—Windows Me and 98



If you use a smart card application, you connect the PC to the serial port on the Select printer. The PC should be set to match the printer serial port settings. This section describes how to set the PC serial port. These settings apply to both a contact smart card module and a contactless smart card module.

Set the serial port on Windows Me and 98

- 1 From the Start menu, select Settings and then Control Panel.
- 2 From the control panel, select System.

- 3 On the system Properties dialog box, select the Device Manager tab.

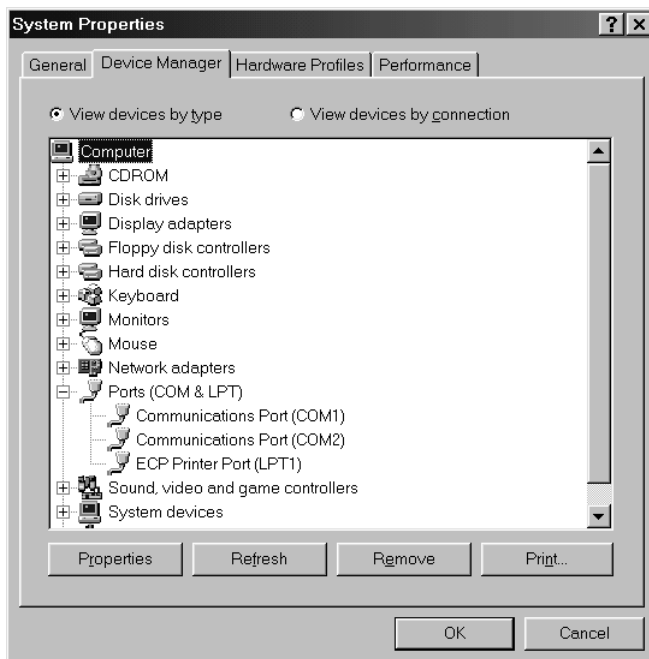

Figure C-5: Device Manager tab of System Properties dialog box

- 4 Click the Plus sign + next to Ports (COM & LPT) to display a list of ports.
 - 5 From the Ports list, select the port, such as COM1 or COM2 (Figure C-5).
 - 6 Select the Properties button to display the port settings.
- i** If the PC has more than one serial port, make sure you view the settings for the serial port to which the printer is attached.

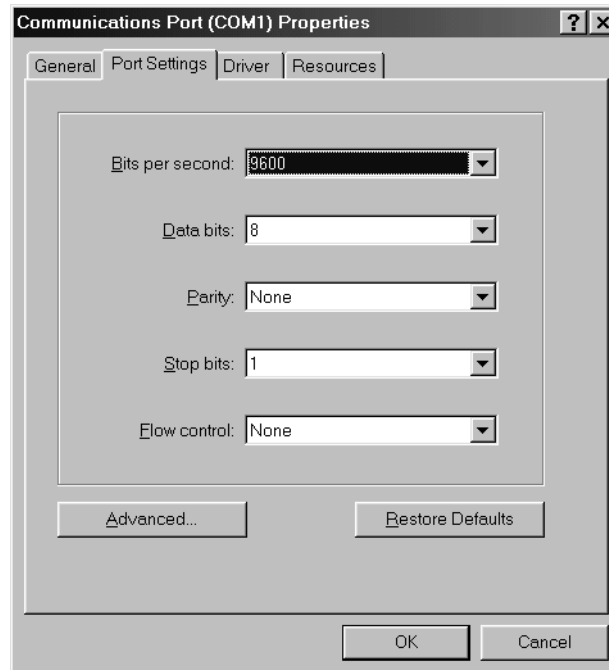

Figure C-6: Settings dialog box

- 7 Select the Port Settings tab.
- 8 Select the following settings:

Setting	Value
Bits per second	9600
Data bits	8
Parity	None
Stop bits	1
Flow control	None

- 9 When the settings are correct, click OK to save settings and close the dialog box.





Magnetic stripe encoding

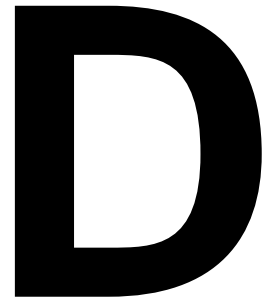

This appendix describes the specifications and characters you can encode on a magnetic stripe in the Select printer, including:

- IATA, ABA, and TTS character sets
- NTT character sets

This appendix also describes basic steps required to set up for magnetic stripe encoding.

i To use custom magnetic stripe formats, such as binary, contact your service provider for more information. To use custom magnetic stripe formats, such as IATA on track 1 and a proprietary format on tracks 2 and 3, your application must use the SmartDriver SDK. You can download the SDK from the Datacard website at www.datacard.com.

IATA, ABA, and TTS character sets

The IAT encoding format selection for the Select printer encodes IATA data on track 1, ABA data on track 2, and TTS data on track 3.

IATA (International Air Transport Association)

The maximum field length for IATA format is 76 characters. IATA allows spaces, upper case alphabetic characters, numeric characters, and the following special characters:

! # \$ % ' () * + , - . / ; : < @ > = ^] \ [" & _

ABA (American Bankers Association)

The maximum field length for ABA format is 37 characters. ABA allows numeric characters and the following special characters:

: ; < = >

TTS (Thrift Third Standard)

The maximum field length for TTS format is 104 characters. TTS allows numeric characters and the following special characters:

: ; < = >

NTT character set

The maximum field length for NTT (Nippon Telephone & Telegraph) format is 69 characters. NTT allows spaces, numeric characters, upper case alphabetic characters, lower case alphabetic characters, and special characters. From a PC running Japanese Windows NT 4.0 or Japanese Windows 98, NTT supports 55 Katakana characters.

The special characters include:

!"#\$%&'()*+,-./:;<=>?@[]^_`{|}~

and the following Japanese-language special characters: (Japanese Windows NT required.)

。 『 』 、 ・ ー ゝ 。

The 55 Katakana characters include the following 45 Katakana characters:

アイウエオ
 カキクケコ
 サシスセソ
 タチツテト
 ナニヌネノ
 ハヒフヘホ
 マミムメモ
 ヤ ュ ヨ
 ラリルレロ
 ワ ン

and the following 10 Katakana characters:

ヲ アイウエオヤユヨツ

Each time you start using Japanese-language characters, or stop using them, the driver adds a hidden character. Each hidden character reduces, by one, the number of characters you can encode.

Magnetic Stripe settings used by the Select printer

The following table presents technical details that apply to encoding magnetic stripe data.

	IATA	ABA	TTS	NTT	Binary
Character Differential	32	48	48	0	0
Start Sentinel (SS) (ASCII character)	% (37)	; (59)	; (59)	127	None
End Sentinel (ES) (ASCII character)	? (63)	? (63)	? (63)	127	None
Lowest ASCII Character	space (32)	0 (48)	0 (48)	(1)	0
Highest ASCII Character	_ (95)	? (63)	? (63)	(126)	255
Character-level parity (VRC)	Odd	Odd	Odd	Even	None
Cumulative parity (LRC)	Even	Even	Even	Even	None
Density in bits per inch	210	75	210	210	210
Data bits per character	6	4	4	7	8
Maximum number of encodable characters (not including start and end sentinel or LRC)	76	37	104	69	33
Encoding direction	SS first	SS first	SS first	SS last	SS first
Start sentinel adjustment	310	320	310	450	310

Magnetic Stripe Setup

Do the following to set up the printer and printer driver to encode magnetic stripes on cards:

- Use cards with magnetic stripes when making a printer test card.
- Determine the coercivity to use. Usually, the coercivity is system-wide decision: magnetic stripe readers are likely to require a specific coercivity value. Card stock is purchased to match that coercivity value. Set the coercivity in the printer driver.
- Select the encoding format. If a custom format, such as triple-IATA, is used, select Binary or "Use Printer coercivity" in the printer driver.



Installation messages

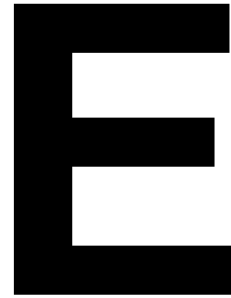

This appendix lists messages displayed during printer installation and describes actions to take based on the messages. The messages are organized in the following groups:

- Driver installation for Windows ME, 98, and NT
- Driver installation for Windows 2000
- Information installation steps (for all operating systems)
- Removing the printer driver for Windows ME, 98, and NT
- Removing the printer driver for Windows 2000

Driver installation for Windows ME, 98, and NT

Key Creation Failure, Key n

Possible Cause	Action
The installation program experienced a problem making entries for the printer driver.	Installation will be cancelled. Run the installation again. If the problem occurs again, see Windows documentation for information about the problems that prevent creation of registry keys.

Dc9inst.dll was not loaded. Canceling installation.

Possible Cause	Action
A component of the installation did not update files successfully.	Installation will be cancelled. Run the installation again. If the problem occurs again, see Windows documentation for information about the problems that prevent updating of MFC libraries.

You need at least 50 Mb of free disk space to install this printer driver.

Possible Cause	Action
The installation program detected that there is too little storage space on the same hard drive as the PC's operating system.	Perform PC maintenance, as described in the e-Guide. If you obtain the printer driver from the Datacard Web site, make sure that you have more than the required amount of disk space after saving the download file and extracting it.

The PC must have Windows NT Service Pack 4 (or higher) installed to continue with this installation. Datacard recommends that you use Service Pack 5 or higher with the printer driver.

Possible Cause	Action
Windows NT 4.0 is installed on the PC but the required service pack is not installed.	Obtain the most recent service pack for Windows NT 4.0 (or the approved service pack for your location) from Microsoft and install it on the PC. Then, install the printer driver.

Adobe Acrobat Reader installation did not complete successfully.

Possible Cause	Action
The Acrobat Reader installation encountered a problem during installation.	Remove all versions of Acrobat Reader to remove any corrupted files. Install Acrobat Reader from the driver CD (see "Printer driver CD-ROM" on page B-8 for the location).
The PC has an existing version of Adobe Acrobat Reader installed.	Remove all versions of Acrobat Reader to remove any corrupted files. Install Acrobat Reader from the driver CD (see "Printer driver CD-ROM" on page B-8 for the location).

The printer name contains a not-allowed () character.

Possible Cause	Action
You changed the printer name and used a character that is not allowed.	The Add Printer Wizard page shows the not-allowed characters. Remove the character from the printer name.



You must have administrator privileges to use this installation.

Possible Cause	Action
You are installing the printer on a PC running Windows NT and you are logged on with a user ID that does not have Administrator privileges.	Cancel installation. Sign off of the current user ID and sign on with the Administrator ID. If needed, ask the Administrator for the PC to perform the installation.

There was an error creating a desktop shortcut for (component).

Possible Cause	Action
A component of the installation program did not create the shortcut successfully.	Create the desktop shortcut to make the information available from the desktop. See Windows help for the steps to follow.

The setup DLL detected an error. Cancelling installation.

Possible Cause	Action
A component of the installation program detected an error.	Windows issued an error, which is recorded in the log file. The log file is located in the "DatacardInstall" folder in the root directory for your operating system.

(printer name) printer driver has been detected. Printer driver with a version lower than 3.0 are not compatible with this driver.

Possible Cause	Action
The PC to which you are installing this printer driver has a Datacard printer with a version of 1.x or 2.x installed.	Refer to the documentation for that driver to remove it. After removing the printer driver, run the Cleanup utility which is on the driver CD.
A Datacard printer with a version of 1.x or 2.x has been removed, but entries for the printer remain.	Run the Cleanup utility which is on the driver CD.

There is not enough disk space to complete this installation. Canceling installation.

Possible Cause	Action
During the installation process, disk space was used by another application, resulting in less than the required amount of disk space.	Perform PC maintenance. See the e-Guide for steps to follow.

You are installing an older printer driver and a current version is installed. Canceling installation.

Possible Cause	Action
You are attempting to install an older version 3.x printer driver and a more recent version 3.x printer driver is installed on the PC.	Use the most current printer driver available for the printer. For available drivers, see the Datacard Web site at www.datacard.com .

You have selected a port that does not exist on the PC. Canceling installation.

Possible Cause	Action
You have selected a port, such as LPT3, and the port does not exist on the PC.	Restart the PC and run the installation again. Select a port that exists on the PC when running the installation again. If the port exists on the PC, see information about the port to troubleshoot its operation.

Do you want to remove the existing printer driver or to install another printer on a different port?

Possible Cause	Action
You have started the installation program (InstallShield) and at least one Datacard printer driver (version 3.0 or higher) is installed.	Select "Install" if the PC has an available parallel port and you plan to install another Datacard printer.
You have selected the printer driver from the Add/Remove Programs dialog box.	Select "Remove existing" to delete the printer driver.



The printer driver can be installed with the Microsoft Windows 95 operating system. Datacard highly recommends that you use Windows 98 Second Edition (SE) or Millennium Edition (Me) with the printer driver to avoid unexpected results.

Possible Cause	Action
You are installing the printer driver on a PC running the Windows 95 operating system.	<p>The installation program permits installation on Windows 95. However, the printer and driver were not tested with this operating system. Install and run the printer at your risk.</p> <p>If you experience problems that you cannot correct, consider upgrading the PC's operating system to Windows 98 SE or Me.</p>

User information installed successfully. Make sure that you install the printer driver using the Detect New Hardware wizard.

Possible Cause	Action
You have run the custom (InstallShield) installation on Windows 2000.	<p>On Windows 2000, installation is a two-part process:</p> <p>The custom installation is required to install the e-Guide and desktop icons (setup.exe on the CD-ROM).</p> <p>The Detect New Hardware wizard installs the driver files.</p> <p>These steps can be performed in any order.</p>

You cannot cancel this installation. Please complete installation and then see the User's Guide for steps to remove the printer driver.

Possible Cause	Action
You have clicked the Cancel button when the custom installation program was installing information and links.	<p>Driver installation is complete: information and links will be installed.</p> <p>To remove the printer driver, go to the Add/Remove programs dialog box or see the e-Guide.</p>

Do you want this printer to be the default printer?

Possible Cause	Action
You can select the default printer when two or more printers are installed on a PC. Usually, the default printer is the most frequently used printer.	If this is the first printer installed on the PC, it will be the default printer (your answer to this question will not affect this). If more than one printer is installed to this PC, you can choose to make this printer the default or use another printer as the default.

An internal error has occurred. Canceling installation.

Possible Cause	Action
An unknown error has occurred.	Windows issued an error, which is recorded in the log file. The log file is located in the "DatacardInstall" folder in the root directory for your operating system. You can run the cleanup utility, located on the driver CD.

A printer with this name already exists. Change the name of this printer to continue installation.

Possible Cause	Action
A printer of the same class (such as Select) with the same version (such as 3.0 or 3.1) is installed on the PC.	Change the name of the printer you are installing and continue with installation.

Unable to install a shortcut in the Startup group.

Possible Cause	Action
Installation attempted to install a shortcut for the printer's Status Monitor in the Windows Startup group.	Create a shortcut in the startup group for the Status Monitor (DsStat.exe). If you are not comfortable creating a shortcut, remove the printer driver, run the Cleanup utility, and reinstall the printer driver.



The e-Guide and Acrobat Reader are not available to install.

Possible Cause	Action
This printer driver was downloaded from the Datacard web site. The components are available for download separately to shorten download times.	If an earlier version of the driver was installed, Acrobat Reader should be installed on the PC. Check the Datacard web site for an updated e-Guide. Download and unzip the file if needed.
This printer driver was copied from the driver CD to another location.	All the files needed for the installation were not copied to the new location. Obtain the e-Guide (see "Printer driver CD-ROM" on page B-8 for the correct location). Also obtain the installation program for Acrobat Reader if it is not installed on the PC.

To install a printer to a USB port, click Cancel, power on the printer,....

Possible Cause	Action
You have selected "USB" from the list of available ports.	All USB devices must be installed using the New Hardware Detected wizard. Cancel this installation. Power on the printer and connect it to a USB port. The New Hardware Detected wizard should appear. If it does not, remove the printer from the Device Manager (see Windows Help for steps to follow).

Acrobat Reader is required to view the e-Guide....

Possible Cause	Action
You have selected "No" for the question about installing the e-Guide.	If the Acrobat Reader is installed on the PC, click No to continue. If the Acrobat Reader is not installed on the PC, click Yes to install the Acrobat Reader, which is required for part of the help system.

You can have up to 31 characters (including spaces) in the name of the printer.

Possible Cause	Action
The name you entered has more than the allowed number of characters.	Use the default name or use a name with less than 31 characters. If you are planning to access this printer from another PC over a network, use a name with 21 or fewer characters so Windows can add network information to the printer name.

An invalid parameter has been detected during printer installation.

Possible Cause	Action
An unknown error occurred during installation.	Restart Windows and run the installation again, following the steps in the User's Guide or e-Guide.

This port is being used by another Datacard printer. Choose another port.

Possible Cause	Action
You have installed a Datacard printer that uses the 3.x printer driver to this parallel port. Only one Datacard printer can be installed to one port at a time.	To install a second printer to the PC, use another parallel port or a USB port. If needed, purchase and install a port for use by the second printer. To update the printer driver for an existing printer, see the <i>e-Guide for ImageCard® Select™ and UltraGrafix® Select™ Printers</i> for steps to follow.

This printer driver cannot be installed on this operating system. Cancelling installation.

Possible Cause	Action
You downloaded a printer driver for Windows NT 4.0 from the Datacard web site, but the PC is running Windows NT 3.51 or lower.	Check the name of the downloaded file and/or the folder to which driver files were extracted. The names should specify the operating system of the PC on which you are attempting to install the printer driver.
You downloaded a printer driver for Windows 98 or Me from the Datacard web site, but the PC is running Windows NT or Windows 2000.	Check the name of the downloaded file and/or the folder to which driver files were extracted. The names should specify the operating system of the PC on which you are attempting to install the printer driver.
You downloaded a printer driver for Windows NT from the Datacard web site, but the PC is running Windows 98 or Me.	Check the name of the downloaded file and/or the folder to which driver files were extracted. The names should specify the operating system of the PC on which you are attempting to install the printer driver.

Could not create the log file. Cancelling installation.

Possible Cause	Action
The installation program attempted to create a log file where the steps of installation are recorded, but it could not create the log file.	Perform PC maintenance, as described in the <i>e-Guide for ImageCard® Select™ and UltraGrafix® Select™ Printers</i> .
You are running the installation program on Windows NT or 2000 and do not have permission to write to the root directory of the PC.	Be sure you have logged on as the Windows Administrator for the PC, to have permission to create folders in the root directory of the PC.

Please restart the PC and run this installation again.

Possible Cause	Action
An error occurred creating files used for installation.	Restart Windows and run the installation again, following the steps in the User's Guide or e-Guide.

Could not access file _____.

Possible Cause	Action
You deleted the printer driver and did not restart Windows afterward.	Cancel installation and restart Windows. Install the printer again. If you receive the message again, run the Cleanup utility (on the CD-ROM) and then install the printer.

The Installation did not complete.

Possible Cause	Action
You have selected a port that does not exist.	Restart Windows and remove printer (using printer name) if it appears in the Printers window. Install the printer driver again and select a port that is available on the PC. If you receive the message again, run the Cleanup utility (on the CD-ROM) and then install the printer.

Driver installation for Windows 2000 only

Digital signature not found.

Possible Cause	Action
The Datacard printer driver does not have a Microsoft digital signature.	Click Yes to continue with installation. Security on the PC might be set to prevent installation without a digital signature. See Windows help for "digital signature" to change the security setting.



Removing the printer driver for Windows ME, 98, and NT

Type in the name of the Datacard printer to remove.

Possible Cause	Action
You used the Add/Remove Programs dialog box to remove a printer.	Enter the name of printer to remove, or cancel and use the Printers window to delete the icon for the printer.

(printer name) is not a Datacard printer, is an invalid name, or it was installed using the Add Printers wizard.

Possible Cause	Action
You used the Add/Remove Programs dialog box to remove a printer, but entered a name that is not accurate for a Datacard 3.x printer.	Canceling removal. Enter the correct printer name, or follow instructions that came with the printer to remove it.



Index

Numerics

2000 e-4-8

A

AC power 1-9
accessories bag 7-3
Add New Hardware Wizard e-4-5, e-4-6, e-4-13
Administrator
 Windows NT C-5, C-6, e-4-2, e-4-10, e-A-5,
 e-A-6
Adobe Acrobat Reader B-7
Advanced Imaging Technology
 about 1-3
 card appearance 5-8
 color settings 3-13
 Premium ribbon 2-4, e-1-8
 print ribbon 1-3
advanced setup 3-11, 3-13, e-4-32
application
 cards 2-9

B

barcodes
 printing intensity e-4-32
box opening 7-2
button
 Ready 1-6, 5-4, e-1-12

C

cable
 connecting 7-5, e-1-3
 data 7-3, 7-4, 7-5, B-9, e-1-1, e-1-2, e-1-3
 ferrite bead e-1-2
 parallel 7-4, B-9, e-1-2
 parallel port specifications 7-4, e-1-2
 power cord 7-7, B-9, e-1-5
 serial 7-5, B-10, e-1-3
 smart card 7-5, B-10, e-1-3
 USB 7-5, B-9, e-1-3, e-4-5
call for assistance 1-9, 7-3
card
 advance knob 1-8
 appearance problems 4-9, e-3-10
 application 2-9
 completed 2-10
 design 2-9, 3-2, 5-3, e-1-11, e-1-17
 exception 1-5

 factory-printed 7-15, e-1-11, e-1-16
 fan when loading e-1-5, e-1-6
 fixing jams e-2-3
 handling 2-2, B-5, e-1-15
 incomplete 2-10
 loading 2-1.e -1-5
 magnetic stripe orientation 2-2, e-1-6
 magnetic stripe test 5-7, e-1-15
 making 2-8
 material B-3
 orientation 3-2, 3-6, 3-7, e-1-17, e-1-21, e-1-22
 picking e-1-5
 position of printing e-4-32
 pre-punched B-4
 printer test 5-4, e-1-13
 printing twice B-4
 quality 5-7, B-5
 remove 2-11
 sample 5-3, e-1-11
 sample card files B-8
 signature panel 4-9, e-3-9
 size B-3
 smart card orientation 2-2, e-1-6
 specifications B-3
 StickICards 4-9, B-4, e-3-9
 storage B-5
 test 5-3, e-1-11
 thickness 2-2, B-3, e-1-6
card cartridge
 about 1-5
 locking 2-1, 2-3, e-1-5, e-1-7
 removing 2-1, e-1-5
 replacing 2-3, e-1-6, e-1-11, e-1-17, e-1-25
card creation application 1-2, 2-9, 2-11, 3-2, 5-3
card output stacker 1-5
cartridge
 print ribbon 2-4, B-10, e-1-8
 printhead B-9
 cascade USB devices e-4-4
CD-ROM
 sample card file 7-15, e-1-16
center printing e-4-32
Check program e-4-27
cleaning
 continuous cleaning roller 1-8
 cycle 4-2, e-3-2
 handling spindle 4-3, e-3-3
 interval 3-3, e-1-17

cleaning

- kit B-6
 - magnetic stripe module 4-5, e-3-5
 - more often 4-2, e-3-2
 - pen 4-9, B-7, e-3-9
 - printer 3-3, 4-2, e-1-17, e-3-2
 - printer cleaning card 4-4, e-3-4
 - printer rollers 4-6, e-3-6
 - printhead 4-9, e-3-10
 - prompt 4-4, e-3-4
 - remove cover from sleeve 4-3, e-3-3
 - replace sleeve 4-2, e-3-2
 - replaceable cleaning sleeve 1-8, B-6
 - roller and sleeve 7-3
 - rollers 4-6, e-3-6
 - run cleaning cycle 3-11
 - SticklCards 4-9, e-3-9
 - tips 4-9, e-3-9
 - using pen 4-6, e-3-6
 - when changing print ribbon 2-5, 4-2, e-1-9, e-3-2
- clearance 6-3
- Cleanup Utility e-4-2, e-4-9
- clearing card jams e-2-3, e-2-5, e-2-6
- client PC e-4-17
- color
- ribbon e-4-28
 - ribbon, see print ribbon B-1
 - Status Monitor icon 3-10
- color settings
- about e-4-32
- colors
- printing intensity e-4-32
- Comman installation e-4-23
- communication
- bi-directional 3-2, e-1-17
- completed cards
- removing 2-11
- connect printer and PC e-1-1
- continuous cleaning roller 1-8, 4-2, 7-3, e-3-2
- cord
- data cable B-9
 - power B-9
 - serial cable B-10

D

- data cable

 - connecting e-1-1

- data port

 - types 1-9

Default Document Properties

- dialog box 3-5, 3-9, e-1-9, e-1-24
 - Windows NT 3-4, e-1-19
- delete
- printer driver e-4-6
- detect New Hardware wizard e-4-5
- Digital Signature Not Found message e-4-14
- dimensions 6-3
- Direct Network Kit B-12
- Disk Cleanup program e-4-26
- Disk Defragmenter program e-4-27
- disk space e-4-26
- driver e-1-17
- driver, See printer driver 6-4
- duplex module
- about 1-3
 - cleaning jams e-2-5
 - location 1-5

E

- ECP parallel port 1-9, 7-4, C-2, e-1-2, e-A-2
- e-Guide e-4-11, e-4-13
- CD-ROM location B-7
 - fixing problems 2-12, e-1-26
 - icon 1-2
- electrical requirements 6-3
- encoder
- ribbon 1-7
- environmental conditions 6-4
- errors
- fixing 2-11, 5-2, e-1-24
- exception card slot 1-5
- express installation e-4-2

F

- factory-printed cards 7-15, e-1-11, e-1-16
- faded cards 5-11
- fixing problems 2-11, 5-2, e-1-24
- fonts
- displaying 2-10
 - magnetic stripe 2-10
 - TrueType 2-9
- Found New Hardware wizard e-4-6, e-4-14

H

- handling cards 2-2, e-1-5
- help

 - message 2-12, e-1-25

- hopper, card output 1-5



host PC
 management e-4-17, e-4-21
 humidity 6-4, B-2, B-6

I

icon
 e-Guide 1-2
 printer 3-3, 3-6, 3-7, 3-8, e-1-18, e-1-21, e-1-22, e-1-23
 status monitor 3-10

image quality
 blank card 5-9
 blank spots 5-8
 blurry image 5-10
 blurry text 5-10
 data unevenly positioned 5-10
 discolored image 5-11
 faded image 5-11
 image not printed 5-9
 image upside down 5-10
 misaligned colors 5-9
 spots 5-12
 unexpected colors 5-9
 unprinted lines 5-8
 unprinted spots 5-11
 wavy lines 5-12
 woodgrain 5-12

ImageCard model 1-3

Imaging Windows program
 print sample card 7-15, e-1-16

installation
 Adobe Acrobat Reader B-7
 audience 6-2
 command e-4-23
 connect more than one printer e-4-1
 Copying Files dialog box e-4-5
 DsPnp.inf file e-4-12, e-4-13
 fixing problems C-5, e-A-5
 messages E-1
 problems 5-2
 sequence 6-5
 set up tips 7-16, e-4-16
 to a second port e-4-3

intensity
 printing e-4-32

L

latch the swing arm e-2-2
 LED, status 1-5, 2-7

light, status 1-5, 2-7
 loading cards 2-1, e-1-5
 locks
 card cartridge lock 1-6
 LPT printer port 7-4, e-1-2

M

magnetic stripe
 fonts at client PC e-4-22

magnetic stripe module
 about 1-4
 cleaning 4-5, e-3-5
 default settings D-3
 fonts 2-10
 load cards 2-2, e-1-6
 setup D-3
 test card 5-7, e-1-15
 test card data 5-5, e-1-13
 track formats D-1

making cards 2-8

manual card feed knob 1-8

margins
 setting print position e-4-32

messages
 buttons 2-12, e-1-26, e-4-26
 Digital Signature Not Found e-4-14
 during installation E-1
 help 2-11, e-1-24
 number 2-12, e-1-25
 on host PC e-4-21
 printer name in title bar e-4-5
 out of memory e-4-26
 status light 2-8
 understanding 2-11, e-1-24

N

network
 kit B-12
 permissions C-8, e-4-21, e-A-7
 printint e-4-17
 requirements e-4-18
 setup e-4-17
 Status Monitor 3-13

O

on switch 1-9
 one-color ribbon B-2
 optional modules 1-3

P

parallel cable

- pass-through not supported 6-5, e-4-3

parallel port

- cable specifications e-1-2
- command installation e-4-23
- connect cable 7-4, e-1-2
- install driver 7-8
- pass-through cable not supported 7-4, e-1-2, e-4-3
- reinstall printer driver e-4-9
- settings C-2, e-A-2

PC

- application 2-9
- card creation application 2-8, 6-4
- client e-4-18, e-4-19
- connecting more than one printer e-4-1
- disk space e-4-26
- environment 6-3
- host e-4-18
- messages 2-11, 5-1, e-1-24
- network setup e-4-17
- ports 7-4, e-1-2
- power on 2-7, e-1-11
- requirements 6-4
- settings C-2, e-A-2

pen, cleaning B-7

physical requirements 6-3

pick rollers 4-6, e-3-6

port

- data 1-9, 6-4
- ECP capable parallel port 6-4, 7-4, C-2, e-1-2, e-A-2
- PC requirement 6-4
- smart card serial 7-5, C-8, C-11, e-1-3, e-A-7, e-A-10
- USB 6-5, 7-5, e-1-3
- USB settings C-4, e-A-4

position of printing e-4-32

power

- cord 7-6, B-9, e-1-4
- PC 2-7, e-1-11
- receptacle 1-9, 6-3
- switch 1-9, 2-7, 5-4, e-1-11, e-1-12
- turn printer on 2-6, e-1-10

print

- jobs e-4-8, e-4-33
- manual duplex e-1-7
- spooler e-4-8, e-4-33

Print Manager e-4-8

- client PC e-4-22

print quality

- blank card 5-8, 5-9
- sample cards 7-15, e-1-16
- See image quality 5-9
- setup tips 7-16, e-4-16
- troubleshooting 5-8

print ribbon

- cartridge 1-8, 2-4, e-1-8
- change type e-4-28
- changing 2-4, e-1-8
- choices depend on duplex setting 3-5, 3-6, 3-9, e-1-19, e-1-22, e-1-24
- color e-4-28
- driver setting 3-2, e-1-17
- lot numbers 5-1
- monochrome B-2
- part numbers B-1, B-2
- premium 1-3, 2-4, B-1, e-1-8
- repair e-2-4
- replacing 2-4, e-1-8
- security 2-10
- storing B-2
- tracker 1-7, 4-9
- type 5-1, B-1, B-2, e-4-28
- visible data 2-5, e-1-9

print spooler

- default setting 3-2, e-1-17

printer

- about 1-2
- access C-6, e-A-6
- beeping 5-2
- cleaning 4-2, e-3-2
- clearance 6-3
- components B-8
- configuration 1-8
- connecting smart card 7-5, e-1-3
- dimensions 6-3
- icon 3-8, e-1-23, e-4-5
- ImageCard 1-3
- label 1-3
- local and network e-4-2
- models 1-3
- more than one per PC e-4-1, e-4-5
- name for shared printer e-4-4, e-4-11
- name with (copy x) e-4-3
- network connected e-4-17
- optional modules 1-3
- package for shipping 5-15
- pause 2-8



- position of printing e-4-32
- power off 2-13, e-1-26
- power on 2-6, e-1-10
- printing intensity e-4-32
- problems 2-11, e-1-25
- recommended supplies B-1
- save values e-4-32
- sharing e-4-17, e-4-18
- serial number 1-3
- status monitor 3-11
- test card 5-4, e-1-3
- troubleshooting 5-2
- update firmware e-4-11
- UltraGrafix 1-3
- unpack 7-2
- values e-4-32
- Printer Diagnostic Utility e-4-2
- printer driver
 - about 1-2
 - CD-ROM 7-3, B-7, e-4-10, e-4-13
 - change settings 3-2, e-1-17
 - client PC e-4-19, e-4-22
 - compatible version e-4-3
 - directly networked e-4-10, e-4-12
 - diskettes 7-8
 - download from Web e-4-10
 - host PC e-4-19, e-4-21
 - install using parallel port 7-8
 - install using USB port 7-11, 7-12
 - installing 7-7
 - installing network client e-4-19
 - messages 2-11, e-1-24
 - order for removal e-4-8
 - PC requirements 6-4
 - reinstalling e-4-6, e-4-9
 - removing e-4-6, e-4-8
 - required settings 7-14, e-4-15
 - sample card file on CD-ROM 7-15, e-1-16
 - settings 3-2, 7-14, e-1-17, e-4-15
 - supported versions e-4-7
 - test page e-4-11
 - update Windows 2000 e-4-12
 - version 3-3, 3-6, 3-7, e-1-18, e-1-21, e-1-22
- printer parts
 - card advance knob 1-8
 - card cartridge 1-5, 2-1, e-1-5
 - locking 1-6
 - card output stacker 1-5, 2-10
 - continuous cleaning roller 4-2, e-3-2
 - data cable 6-5, 7-4, 7-5, B-9, e-1-2, e-1-3, e-4-3
 - data port 1-9
 - duplex module 1-5
 - ECP parallel cable 6-5, 7-4, e-1-2, e-4-3
 - ECP parallel port 1-9
 - exception card slot 1-5
 - parallel port 1-9
 - power button 1-9
 - power cord 7-6, B-9, e-1-4
 - power receptacle 1-9, 7-6, e-1-4
 - power switch 1-9, 2-7, e-1-11
 - print ribbon cartridge 1-8
 - printhead cartridge 1-7, 4-11, B-8, e-3-11
 - ready button 1-6
 - replaceable cleaning sleeve 4-2, e-3-2
 - ribbon tracker 4-9, e-3-9
 - smart card module 1-5
 - smart card serial port 1-9, 7-5, e-1-3
 - status light 1-5, 2-7
 - supplies B-1
 - swing arm 1-7, 2-4, e-1-8
 - top cover 1-5, 2-4, e-1-8
 - USB cable 7-5, e-1-3
 - USB port 1-9
 - Printer Preferences
 - Windows 2000 3-8, e-1-23
 - printer values e-4-32
 - Printers window e-4-9
 - printhead cartridge
 - about 1-7
 - changing e-4-28
 - cleaning 4-9, e-3-10
 - part number B-8
 - replacing 4-11, e-3-11
 - printing
 - discolored 2-2, e-1-5
 - duplex 3-6, e-1-21
 - front only 2-10
 - full-color 1-2, 1-3
 - monochrome 1-2, 1-3, B-2
 - on both sides 3-5, e-1-19
 - same card twice B-4
 - text 2-9
 - problems
 - card picking e-1-5
 - card quality 4-9, e-3-10
 - discolored printing 2-2, e-1-5
 - duplex module e-2-5, e-2-6
 - fixing 2-11, 5-2, e-1-4
 - fixing card jams e-2-3
 - print ribbon e-2-4
 - isolating 5-2
 - repeated card jams 4-6, e-3-6

problems
 smart card module e-2-6
 program
 card creation 6-5
 printer driver 6-4
 Properties
 Windows 2000 3-7, e-1-22, e-4-12
 Windows 2000 Printer Preferences 3-8, e-1-23
 Windows Me and 98 3-6, e-1-21
 Window NT 3-3, e-1-18
 Windows NT Default Document 3-5, e-1-19
 Windows NT dialog box 3-3, e-1-18
 punched card B-4

Q

quality
 cards B-3
 printing 5-8
 supplies B-2
 troubleshooting 5-1
 Quick Install Chart 7-2

R

ready button 1-6, 5-4, e-1-12
 recommended supplies B-1
 registration
 position of printing e-4-32
 regulatory compliance A-1
 remove cards 2-11
 remove printer driver e-4-6
 repairs 5-14
 replace printhead cartridge 4-11
 Replaceable cleaning sleeve B-6
 replace printhead cartridge e-3-11
 replaceable cleaning sleeve 1-8, 4-2, 7-3, B-6, e-3-2
 requirements
 card storage B-5
 data cable 7-3, e-1-1
 electrical 6-3
 environmental 6-4
 physical 6-3
 power cable e-1-1
 site 6-2
 supplies storage 6-2
 ribbon tracker 4-9, e-3-9
 ribbon, See print ribbon B-1, B-2
 rollers
 cleaning 4-6, e-3-6

S

safety A-2
 sample card files B-8
 sample cards 5-3, e-1-11
 save printer values e-4-32
 ScanDisk program e-4-26
 security
 data on print ribbon 2-5, e-1-9
 incomplete cards 2-10, 2-11
 key 6-4
 PC e-4-14
 print ribbon 2-10, e-2-4
 supplies 2-13, e-1-17
 serial cable
 smart card 7-5, B-10, e-1-3
 serial number 1-3, 1-8
 serial port 1-9, 7-5, e-1-3
 service
 messages 2-11, e-1-24
 obtaining 5-14
 who to call 1-9, 5-1, 7-3
 Service Pack for Windows 2000 7-7, e-4-12
 Service Pack for Windows NT 4.0 7-7, e-4-9
 settings
 bi-directional support 3-2, e-1-17
 color 1-3, e-4-32
 color settings on client PC e-4-22
 default 3-2, e-1-17
 for sample card 7-15, e-1-16
 not available 3-5, 3-9, e-1-20, e-1-24
 print ribbon type e-4-28
 printer connected 3-2, e-1-17
 printer values e-4-32
 required 7-14, e-4-15
 sequence 3-5, 3-6, 3-9, e-1-19, e-1-22, e-1-24
 spool 3-2, e-1-17
 setup tips 7-16
 ship the printer 5-15
 shipping
 carton 5-15, 7-2
 printer 5-15
 site requirements 6-2
 smart card
 about 1-4
 clearing jams e-2-6
 combination 7-6, e-1-4
 contact 7-5, e-1-3
 contact station 7-5, e-1-3
 contactless 7-6, e-1-4
 loading cards 2-2, e-1-6
 module 1-5



- processing cards e-4-24
 - serial cable B-10
 - serial port 1-9, 7-5, e-1-3
 - Software Developer's Kit 2-9, B-12
 - Start menu 7-9, e-4-9
 - status light
 - about 1-5
 - blink amber without message 2-11
 - description 2-7
 - Status Monitor
 - about 3-10
 - advanced setup 3-13
 - client PC e-4-22
 - close 3-13
 - exit 3-11, 3-13
 - more than one printer e-4-5
 - suspend 3-12
 - using 3-11
 - view details 3-12
 - storage
 - cards B-5
 - conditions 6-2
 - supplies 6-2, B-2
 - supplies
 - authorized B-1
 - storage 6-2, B-2
 - swing arm 1-7
 - latch e-2-2
 - open e-2-2
 - switch
 - Power 1-9, 2-7, 5-4, e-1-11, e-1-12
 - symbol
 - printer 3-10
- T**
- temperature 6-4, B-2
 - test card
 - magnetic stripe 5-3, 5-7, e-1-11, e-1-15
 - magnetic stripe encoding 5-3, e-1-12
 - printer 5-3, 5-5, e-1-11, e-1-13
 - purposes 5-3, e-1-11
 - sample e-1-11
 - Windows test page 5-3, 5-5, e-1-11, e-1-14
 - test page
 - Windows 5-5, 5-6, e-1-14, e-4-11
 - text
 - printing intensity e-4-32
 - topcoat panel
 - printing intensity e-4-32
 - top cover 1-5
 - tracker
 - print ribbon 1-7
 - trademarks A-3
 - transport area rollers 4-7, e-3-7
 - troubleshooting
 - guide 5-2
 - print quality 5-8
 - printer 5-3
 - type style 2-9
- U**
- UltraGrafix models 1-3
 - Universal Serial Bus (USB) port 1-9
 - USB
 - cable B-9
 - cable specifications e-1-3
 - command install not supported e-4-23
 - connect cable 7-5, e-1-3
 - connecting more than one printer e-4-1
 - maximum number of hubs e-4-4
 - port 1-9
 - port settings C-4, e-A-4
 - supported operating systems e-4-3
 - troubleshooting e-4-5
 - utilities
 - Check e-4-27
 - Cleanup B-8, e-4-2, e-4-9
 - Disk Cleanup e-4-26
 - Disk Defragmenter e-4-27
 - firmware e-4-12
 - firmware update e-4-14
 - printer diagnostics e-4-2
 - ScanDisk e-4-26
 - SmartDriver Diagnostics B-8
- V**
- voltage
 - printing e-4-32
- W**
- Web
 - download driver e-4-2
 - weight 6-3
 - who to call for assistance 1-9, 7-3
 - Windows
 - printer sharing e-4-17
 - reinstalling printer driver e-4-13
 - removing the printer driver e-4-6
 - test page 5-5, 5-6, e-1-14, e-4-11

Windows

- test page wizard 5-6, e-1-14
- upgrading the printer driver e-4-6

Windows 2000

- administration e-4-14
- host PC permission e-4-21
- New Driver button e-4-12
- permission to delete printer e-4-8
- permissions 7-14, C-6, e-4-15, e-4-18
- Printer Preferences 3-8, e-1-23
- printer sharing e-4-17
- Properties 3-7, e-1-22
- reinstall printer driver e-4-14
- rename printer e-4-3
- Service Pack e-4-7, e-4-12
- update printer driver e-4-12
- USB port 6-5

Windows Me and 98

- edition recommended e-4-7
- PC settings C-10, e-A-9

- printer sharing e-4-17
- Properties 3-6, e-1-21
- reinstall printer driver e-4-9
- USB port 6-5
- User Profiles e-4-10

Windows NT

- Default Document Properties 3-5, 3-9, e-1-19, e-1-24
- host PC permission e-4-21
- installing printer driver e-4-8
- network permissions e-4-21
- PC settings C-5, e-A-5
- permission to delete printer e-4-8
- permissions 7-14, C-6, e-4-15, e-4-18, e-A-6
- printer sharing e-4-17
- Properties 3-3, e-1-18
- reinstall printer driver e-4-9
- Service Pack e-4-7
- USB not supported e-4-3



Free Manuals Download Website

<http://myh66.com>

<http://usermanuals.us>

<http://www.somanuals.com>

<http://www.4manuals.cc>

<http://www.manual-lib.com>

<http://www.404manual.com>

<http://www.luxmanual.com>

<http://aubethermostatmanual.com>

Golf course search by state

<http://golfingnear.com>

Email search by domain

<http://emailbydomain.com>

Auto manuals search

<http://auto.somanuals.com>

TV manuals search

<http://tv.somanuals.com>