



MWA 2434 MM

You can rely on Defy. To simplify.

AIR FRYER MICROWAVE OVEN

Users Manual

Record in the space below the listed information for future reference.

SERIAL NUMBER

DATE OF PURCHASE

PURCHASED FROM

.....

The manufacturer strives for continuous improvement. For this reason, the text and illustrations in this manual are subject to change without notice.

Before operating this oven, please read these manual completely.

PRECAUTIONS TO AVOID POSSIBLE EXPOSURE TO EXCESSIVE MICROWAVE ENERGY

- (a) **Do not attempt to operate this oven with the door open** since open-door operation can result in harmful exposure to microwave energy. It is important not to defeat or tamper with the safety interlocks.
- (b) **Do not place any object** between the oven front face and the door or allow soil or cleaner residue to accumulate on sealing surfaces.
- (c) **WARNING** : If the door or door seals are damaged, the oven must not be operated until it has been repaired by a competent person : (1) door (bent), (2) hinges and latches(broken or loosened), (3) door seals and sealing surfaces.
- (d) **WARNING** : It is hazardous for anyone other than a competent person to carry out any service or repair operation that involves the removal of a cover which gives protection against exposure to microwave energy.
- (e) **WARNING** : Liquids and other foods must not be heated in sealed containers since they are liable to explode.

PRECAUTIONS TO AVOID POSSIBLE EXPOSURE TO EXCESSIVE MICROWAVE ENERGY

- (f) WARNING :** This appliance can be used by children aged from 8 years and above and persons with reduced physical, sensory or mental capabilities or lack of experience and knowledge if they have been given supervision or instruction concerning use of the appliance in a safe way and understand the hazards involved. Children shall not play with the appliance. Cleaning and user maintenance shall not be made by children unless they are aged from 8 years and above and supervised.
- (g) WARNING :** When the appliance is operated in the combination mode, children should only use the oven under adult supervision due to the temperature generated.(if provided)
- (h) WARNING :** The appliance and its accessible parts become hot during use.
Care should be taken to avoid touching heating elements.
Children less than 8 years of age shall be kept away unless continuously supervised.



TABLE OF CONTENTS

• INSTALLATION AND EARTHING INSTRUCTIONS	4
• IMPORTANT SAFETY INSTRUCTIONS	5
• WHICH UTENSILS CAN BE USED IN THE OVEN?	8
• What is a function, STANDBY POWER "0"?	9
• CONTROL PANEL	10
• ACCESSORIES	11
• How to use the Home Fryer bowl	12
• OPERATION	13
MICROWAVE COOKING	13
GRILL COOKING	14
CONVECTION COOKING (with pre-heat)	15
CONVECTION COOKING (traditional cooking)	16
COMBINATION COOKING	18
DEODORIZATION	19
STEAM CLEANING (with Microwave Feature)	19
WEIGHT DEFROST	20
TIME DEFROST	20
HOME FRYER	21
AUTO COOK	23
+30sec	24
TO STOP THE OVEN WHILE THE OVEN IS OPERATING	24
STAND-BY POWER "0"	24
ABNORMAL MESSAGES	24
WARNING	24
• GENERAL GUIDELINES	25
• KEEP THE OVEN CLEAN	26
• BEFORE CALLING FOR SERVICE	27
• QUESTIONS AND ANSWERS	28
• SPECIFICATIONS	29
• DISPOSAL OF USED ELECTRICAL & ELECTRONIC EQUIPMENT	29
• COOKING INSTRUCTIONS	30
• SERVICE CENTRES	31
• WARRANTY	32



INSTALLATION AND EARTHING INSTRUCTIONS

How to examine your microwave oven after unpacking.

Unpack oven, remove all packing material, and examine the oven for any damage such as dents, broken door, latches or cracks in the door. Do not remove the film from inside the door. Notify dealer immediately if the oven is damaged. Do not install if the oven is damaged.

Where to place your microwave oven.

1. Place the oven on a flat and stable surface.
2. The microwave oven shall not be placed in a cabinet unless it has been tested in a cabinet.
3. Surface of the oven is protected by a plastic film which should be removed before using.
4. Leave space behind and sides and upper of the oven. All air vents should be kept a clearance.
If all vents are covered during operation, the oven may overheat and, eventually, lead to oven failure.
5. Keep away from radio and TV sets. If the oven is located close to a TV, radio interference may result.
6. Keep away from heating appliances and water taps. Keep the oven away from hot air, steam or splash when choosing a place to position it, or the insulation might be adversely affected and breakdowns occur.

7. The minimum height of free space necessary above the top surface of the oven is minimum 170mm.

Prior to use (If your oven has a grill element)

In order to protect your oven during transportation and storage, the grill element is covered with a protective coating. To remove this coating the grill element must be heated for 5 minutes. This procedure will produce some bad odours as the protective coating on the element disappears.

To remove the coating, use the following procedures:

1. Press the convection button.
2. Set the max temperature to 5 minutes.
3. Set the time to 5 minutes.
4. When the 5 minutes has elapsed, an acoustic signal sounds.
5. Open the oven door and remove the bowl with water (use oven gloves when removing the bowl).

Note:

The protective coating has now been removed and the oven is ready to use. Please be aware that your oven now is very hot.

- **WARNING:** Only allow children to use the oven without supervision when adequate instructions have been given so that the child is able to use the oven in a safe way and understands the hazards of improper use.

Electrical Connection

WARNING-THIS APPLIANCE MUST BE EARTHED.

REFER TO RATING PLATE FOR VOLTAGE AND CHECK THAT THE APPLIANCE VOLTAGE CORRESPONDS WITH THE SUPPLY VOLTAGE IN YOUR HOME.

IMPORTANT-The wires in the mains lead fitted to this appliance are coloured in accordance with the following code

GREEN AND YELLOW-EARTH
BLUE-NEUTRAL
BROWN-LIVE

As the colour of the wires in the mains lead of this appliance may not correspond with the coloured markings identifying the terminals in your plug, proceed as follows:

Power supply

- Check your local power source. This oven requires a current of approximately 11 amperes, 230V 50Hz.
- Power supply cord is about 1.2 meters long.
- The voltage used must be the same as specified on this oven. Using a higher voltage may result in a fire or other accident causing oven damage. Using low voltage will cause slow cooking. We are not responsible for damage resulting from use of this oven with a voltage of ampere fuse other than those specified.
- If the supply cord is damaged, it must be replaced by the manufacturer or its service agent or a similarly qualified person in order to avoid a hazard.

The wire which is coloured GREEN AND YELLOW must be connected to the terminal in the plug which is marked with the letter "E" or the earth symbol \perp or coloured GREEN AND YELLOW, or GREEN.

The wire which is coloured BLUE must be connected to the terminal which is marked with the letter "N" or coloured BLACK, or BLUE.

The wire which is coloured BROWN must be connected to the terminal which is marked with the letter "L" or coloured RED, or BROWN.

If the terminals in the plug are unmarked or you are in any doubt as to the correct connections, consult a qualified electrician.

If you do not make the proper electrical connections you will damage your microwave oven and possibly injure yourself. Neither the manufacturer nor the supplier are liable if this happens.

MOULDED PLUGS

Should it be necessary to remove a moulded on plug from the mains cable, it should be cut off and replaced with a suitable replacement.

The moulded plug cannot be used for any other appliance, therefore remove the fuse and dispose immediately and safely to prevent anyone, especially children from plugging it in to a wall socket, which will create a safety hazard.

Should the mains lead ever require replacement, it is essential that this operation be carried out by a qualified electrician and should only be replaced with a flexible cord obtained from the manufacturer.



IMPORTANT SAFETY INSTRUCTIONS

READ CAREFULLY AND KEEP FOR FUTURE REFERENCE.

WARNING : To prevent fire, burns, electric shock and other warnings:

Listed below are, as with all appliances, certain rules to follow and safeguards to assure high performance from this oven:

1. Do not use the oven for any reason other than food preparation, such as for drying clothes, paper, or any other nonfood items or for sterilizing purposes.
2. Do not use the oven when empty, this could damage the oven.
3. Do not use the oven cavity for any type of storage, such as papers, cookbook, cookware, etc.
4. Do not operate the oven without the metal tray in place. Be sure it is properly sitting on the rotating base.
5. Make sure you remove caps or lids prior to cooking when you cook food sealed in bottles.
6. Do not put foreign material between the oven surface and door. It could result in excessive leakage of microwave energy.
7. Do not use recycled paper products for cooking. They may contain impurities which could cause sparks and/or fires when used during cooking.
8. Do not pop popcorn unless popped in a microwave approved popcorn popper or unless it's commercially packaged and recommended especially for microwave ovens. Microwave popped corn produces a lower yield than conventional popping; there will be a number of unpopped kernels. Do not use oil unless specified by the manufacturer.
9. Do not cook any food surrounded by a membrane, such as egg yolks, potatoes, chicken livers, etc., without first piercing them several times with a fork.
10. Do not pop popcorn longer than the manufacturer's directions. (popping time is generally below 3 minutes). Longer cooking does not yield more popped corn, it can cause scorchings and fire. Also, the cooking tray can become too hot to handle or may break.
11. If smoke is emitted, switch off or unplug the appliance and keep the door closed in order to stifle any flames.
12. When heating food in plastic or paper containers, keep an eye on the oven due to the possibility of ignition.

13. The contents of feeding bottles and baby food jars shall be stirred or shaken and the temperature checked before consumption, in order to avoid burns.
 14. Always test the temperature of food or drink which has been heated in a microwave oven before you give it to somebody, especially to children or elderly people. This is important because things which have been heated in a microwave oven carry on getting hotter even though the microwave oven cooking has stopped.
 15. Eggs in their shell and whole hard-boiled eggs should not be heated in microwave ovens since they may explode, even after microwave heating has ended;
 16. Keep the waveguide cover clean at all times. Wipe the oven interior with a soft damp cloth after each use. If you leave grease or fat anywhere in the cavity it may overheat, smoke or even catch fire when next using the oven.
 17. Never heat oil or fat for deep frying as you cannot control the temperature and doing so may lead to overheating and fire.
 18. Microwave heating of beverages can result in delayed eruptive boiling, therefore care must be taken when handling the container.
- To reduce the risk of injury to persons:**
- a) Do not overheat the liquid.
 - b) Stir the liquid both before and halfway through heating it
 - c) Do not use straight-sided containers with narrow necks.
 - d) After heating, allow the container to stand in the microwave oven for a short time before removing the container.
 - e) Use extreme care when inserting a spoon or other utensil into the container.
19. This appliance is not intended for use by persons(including children) with reduced physical, sensory or mental capabilities, or lack of experience and knowledge, unless they have been given supervision or instruction concerning use of the appliance by a person responsible for their safety.
 20. Children should be supervised to ensure that they do not play with the appliance.
 21. Only use utensils that are suitable for use in microwave ovens.
 22. During use the appliance becomes hot. Care should be taken to avoid touching heating elements inside the oven.
 23. Do not use a steam cleaner in the oven.

SAVE THESE INSTRUCTIONS



General Use

Listed below are, as with all appliances, certain rules to follow and safeguards to assure top performance from this oven:

1. Do not use the oven for any reason other than food preparation, such as for drying clothes, paper, or any other nonfood items or for sterilizing purposes. They may catch on fire.
2. Do not use the oven when empty, this could damage the oven.
3. Do not use the oven cavity for any type of storage, such as papers, cookbook, cookware, etc.
4. Do not operate the oven without the turntable tray in place. Be sure it is properly sitting on the rotating base.
5. Be caution when removing the turntable tray after cooking meats that may have caused an accumulation of grease in the tray.
6. Unlike microwave-only ovens, this oven may become hot on the cabinet and oven door. Always use hot pads or oven mitts when placing or removing food and/or accessories from the oven. Be cautions about touching parts other then control panel during or immediately following grill or combination cooking.
7. If the oven is hot from combination cooking, do not use plastic or Styrofoam cookware for microwave cooking. They may melt.
8. Do not use recycled paper products for cooking. They may contain impurities which could cause sparks and/or fires when used during cooking.
9. Do not continue to cook with metal utensils if sparking appears. See "Accessories" section on page 8 for proper use of cookware.
10. Do not leave the oven unattended during short cooking times. Overcooking and fire may result.
11. Do not cook any food surrounded by a membrane, such as egg yolks, potatoes, chicken livers, etc., without first piercing them several times with a fork.
12. Do not pop popcorn unless popped in a microwave approved popcorn popper or unless it's commercially packaged and recommended especially for microwave ovens. Microwave popped corn produces a lower yield than conventional popping; there will be a number of unpopped kernels. Do not use oil unless specified by the manufacturer.
13. Do not attempt to operate this appliance with the door open.
14. Do not attempt to remove covers, panels, etc.
15. Look at the oven from time to time when food is heated or cooked in disposable containers of plastic, paper or other combustible materials.
16. If smoke is emitted, switch off or unplug the appliance and keep the door closed in order to stifle any flames.
17. Microwave heating of beverages can result in delayed eruptive boiling, therefore care has to be taken when handling the container.
18. Make sure you remove caps or lids prior to cooking when you cook food sealed in bottles.
19. Do not put foreign material between the oven surface and door. It could result in excessive leakage of microwave energy.
20. Do not pop popcorn longer than the manufacturer's directions. (popping time is generally below 3 minutes). Longer cooking does not yield more popped corn, it can cause scorchings and fire. Also, the cooking tray can become too hot to handle or may break.
21. When heating food in plastic or paper containers, keep an eye on the oven due to the possibility of ignition.
22. Always test the temperature of food or drink which has been heated in a microwave oven before you give it to somebody, especially to children or elderly people. This is important because things which have been heated in a microwave oven carry on getting hotter even though the microwave oven cooking has stopped.
23. Eggs in their shell and whole hard-boiled eggs should not be heated in microwave ovens since they may explode, even after microwave heating has ended;
24. Keep the waveguide cover clean at all times. Wipe the oven interior with a soft damp cloth after each use. If you leave grease or fat anywhere in the cavity it may overheat, smoke or even catch fire when next using the oven.
25. Never heat oil or fat for deep frying as you cannot control the temperature and doing so may lead to overheating and fire.
26. During use the appliance becomes hot. Care should be taken to avoid touching heating elements inside the oven.



TO AVOID EXPLOSION AND SUDDEN BOILING

WARNING

Liquids, such as water, coffee, or tea are able to be overheated beyond the boiling point without appearing to be boiling due to surface tension of the liquid. Visible bubbling or boiling when the container is removed from the microwave oven is not always present. This could result in very hot liquids suddenly boiling over when a spoon or other utensil is inserted into the liquid.

To reduce the risk of injury to persons:

- Do not overheat the liquid.
- Stir the liquid both before and halfway through heating it
- Do not use straight-sided containers with narrow necks.
- After heating, allow the container to stand in the microwave oven for a short time before removing the container.
- Use extreme care when inserting a spoon or other utensil into the container.

1. Eggs

Never cook eggs in their shells. Steam will build up inside the shell during cooking and the egg will explode.

If you want to cook or reheat eggs which have not been broken up by scrambling or mixing, you must always pierce the yolks or these will also explode. You should slice shelled hard boiled eggs before you reheat them in your microwave oven.

2. Piercing

Always pierce food which has a skin or membrane, for example, potatoes, tomatoes, apples, sausages etc. If you don't pierce them, steam will build up inside and they may explode.

3. Lids

Always remove the lids of jars and containers and take away food containers, before you cook using your microwave oven. If you don't, then steam and pressure might build up inside and cause an explosion even after the microwave cooking has stopped.

WHICH UTENSIL CAN BE USED IN THE OVEN?

Only use utensils that are suitable for use in microwave ovens. Before use, the user should check that utensils are suitable for use in microwave ovens.

Material	Grill & Convection cooking	Microwave cooking	Combined cooking
Glass (general)	No	Yes (1)	No
Glass (heat resistant)	Yes	Yes	Yes
Glass-ceramic and ceramic (heat resistant)	Yes	Yes (1)	Yes (1)
Earthenware	Yes	Yes	Yes
China (heat resistant)	Yes	Yes	Yes
Plastic (general)	No	Yes (2)	No
Plastic (heat resistant)	Yes (2)	Yes (2)	Yes (2)
Aluminium foil containers /aluminium foil	Yes	Yes (3)	Yes
Metal baking tins	Yes (4)	No	Yes (4)
Metal (pots.pans, etc)	Yes	No	No
Paper	No	Yes	No

Utensils made of china and ceramic are excellent to use in your microwave oven. Most types of glass are also very good. Lead crystal glass can crack and should therefore, not be used. Plastics and paper can also be used, provided they can withstand the temperature of the heated food. For cooking only use plastics, which will withstand a temperature of over 120°C, e.g. polypropene and polyamide. Some plastic materials, e.g. melamine, will be heated by the microwave, and be damaged. To find out if a certain container is suitable, the following simple test can be made:

Place the empty container and a glass of water inside the microwave oven. The water is needed because the oven must not be operated empty or with empty containers only. Let the oven work on full power for one minute. A suitable container will only be lukewarm.

Metal containers, e.g. saucepans or frying pans should not be used in microwave ovens. Nor should plates or vessels with decorations be used since metal e.g. gold, might be part of the decoration and such decorations will be damaged.

Small pieces of aluminium foil can be used, but only to shield the areas that would over-cook (e.g. for covering chicken wings, leg tips and fish tails) but the foil must not touch the side of the oven as damage may occur.



- Without metal parts or metal trims.
- Some plastics are heat-proof only to certain temperatures. Check carefully!
- It is possible to use aluminium foil to shield delicate areas of food (this prevents over-cooking).
- Metal tins can be used in the combination methods, however if these are very deep, they will greatly reduce the efficiency, as metal shields the microwave energy from the food.

Microwave function only

Utensils and cooking containers used in a microwave oven should be of a material that does not act as a barrier to microwave energy. Generally this means that you should cook in either (paper), plastic, glass or ceramic. Metal pans reflect microwave energy and inhibit cooking, and should not be used. In addition to material, the shape of the container should also be considered. Round oval shapes give the most even cooking. Square or rectangular containers may over-cook foods in the corners because more energy is absorbed there. Shallow containers give more even cooking results.

Caution:

- There are a number of accessories available on the market. Before you buy, make sure they are suitable for microwave use.
- When you put food in the microwave oven, make sure that food, food supports or covering do not come in direct contact with any of the internal walls or the ceiling of the cavity since discolouration may take place.



What is a function, STANDBY POWER “0”?

- Standby power is the electric power consumed by electronic appliances without operating on inserting the plug into a socket.
- STANDBY POWER “0” is function reducing standby power consumption.
- This product can save energy in a standby mode, by setting the STANDBY POWER “0” mode.
To turn on the oven, press and hold ZERO ON button until display is switched on and a beep sounds after plugging in.
The oven goes to STANDBY POWER “0” mode automatically after 10 minutes without using or press and hold STOP/CLEAR button until display is turned off.
Press and hold ZERO ON button again until display is switched on and a beep sounds, you can use the oven.

- If you insert plug into a socket, the oven is STANDBY POWER “0” mode. So the display shows nothing. To cancel STANDBY POWER “0” mode, press and hold ZERO ON button until display is switched on and a beep sounds.
(Because automatically the oven is powered off after 10 minutes without using.
The display shows nothing.)

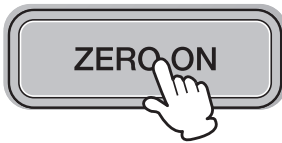

CONTROL PANEL



- ① **Display** : Cooking time, power level and indicators are displayed.
M/W : When flashing, the oven is operating in MICROWAVE COOK.
Grill : When flashing, the oven is operating in GRILL.
Combi : When flashing, the oven is operating in COMBI.
Convection : When flashing, the oven is operating in CONVECTION.
Defrost : When flashing, the oven is operating in AUTO DEFROST.
Auto Cook : When flashing, the oven is operating AUTO COOK and HOME FRYER COOK.
Deodorization : When Flashing, the oven is operating DEODORIZATION.
Steam Cleaning : When flashing, the oven is operating STEAM CLEANING.
g : When flashing, the oven is operating in weight input mode.
- ② **Home fryer** : Used to select Home fryer.
- ③ **Auto cook** : Used to select Auto cook
- ④ **M/W** : Used to set power level of microwave.
- ⑤ **Combi** : Used to select combi.
- ⑥ **Convection** : Used to select convection and selected temperature.
- ⑦ **Grill** : Used to select grill.
- ⑧ **Defrost** : Used to defrost foods for weight or time.
- ⑨ **Deodor. / Steam cleaning** : Used to deodorize oven or to clean oven.
- ⑩ **START/+30sec** : Used to start a Programme, also for speedy start(each press adds 30 seconds microwave cooking time).
- ⑪ **STOP/Clear** : Used to stop the oven operation or to delete the cooking data.
- ⑫ **Dial knob** : Used to set time, weight and quantity.



ACCESSORIES

This oven comes equipped with several accessories. They can be used in various ways to facilitate cooking.

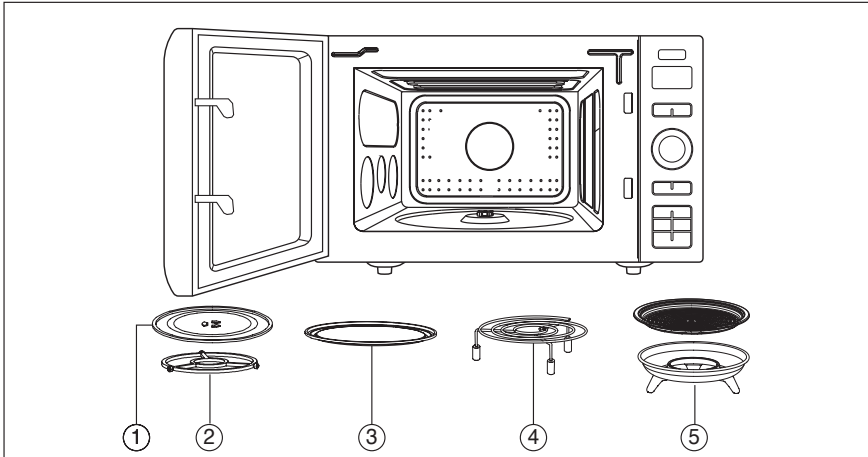

1 Glass Turntable - Center the tray on the roller guide when using the microwave features. Place food or microwave-safe cookware directly on the glass turntable.

NOTE : Glass Turntable is attached to the right cushion pad.

2 Roller Guide - The roller guide must be in place when using the oven.
IMPORTANT : The roller guide must be placed in the center of the oven's cavity.

3 Metal Tray - Put food or appropriate cookware directly on the metal tray and place on the glass turntable and then place on the roller guide when using convection cooking, combination cooking, auto cooking or grill cooking.

4 Metal Rack - Center the rack on the metal tray when using the grill cooking and Auto cooking menu 1,2,3,4.

5 Home Fryer Bowl - Center the kit on the metal tray when using the Home fryer cooking.

■ HOW TO USE THE ACCESSORIES OF COOKING

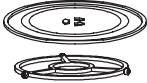
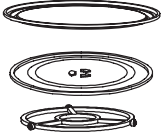
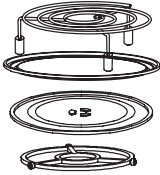
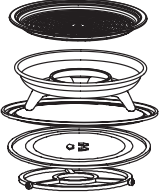
■ Glass Turntable	■ Metal Tray	■ Metal rack	■ Home Fryer bowl
 <ul style="list-style-type: none"> • Microwave cooking 	 <ul style="list-style-type: none"> • Convection cooking • Combination cooking • Auto cooking menu 5 	 <ul style="list-style-type: none"> • Grill cooking • Auto cooking menu 1,2,3,4 • Convection cooking (cake,pizza,pie) 	 <ul style="list-style-type: none"> • Home fryer cooking.

NOTE : Metal Tray must not be used in microwave cooking.





How to use the Home Fryer bowl.

■ Composition of Home Fryer bowl.

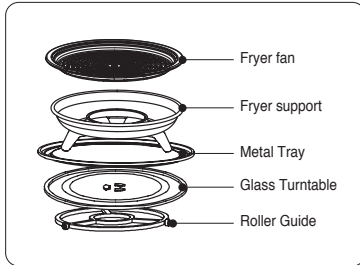

CAUTION : Please use the kitchen gloves while taking out the Home Fryer bowl because it is very hot.

■ How to use the Home Fryer bowl.

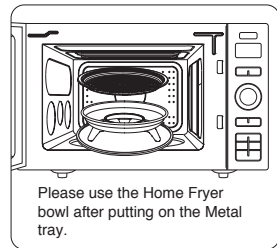

■ Cautions while using the Home Fryer bowl.

- ① Please always use the Home Fryer bowl after putting on the Metal tray.
- Never use this bowl with other dishes and trays. Home Fryer and Home Fryer bowl can be damaged.
- ② Please place the Fryer fan on the Fryer support solidly.
- ③ Please place the foods on the Fryer fan evenly.
- ④ Please use kitchen gloves while taking out the Home Fryer bowl because it is very hot.
- ⑤ Please be careful when taking out the Home Fryer bowl after cooking is done.

CAUTION :

Please clean the Home Fryer bowl. Sparks can occur if there are foreign substances on it.
Home Fryer bowl can be used only for "Home Fryer". When it is used for a gas range or other products, it may cause a malfunction or fire.

CAUTION :

Please wash the Home Fryer bowl immediately after cooking.
Please use a neutral detergent and soft sponge.



OPERATION

Tips : Also remember to read this operating instructions for proper safety information and instruction before using the oven. Prior to setting the controls, place one cup of water in the oven, on a heat-proof glass measuring cup, for testing purposes.

Note : When the cooking time has elapsed the oven beeps three times, "End" appears in the display, the rotating plate stops turning and the oven light turns off. The oven will continue to beep every 1 minute until the **STOP/Clear** button is pressed, or the door is opened.
The cooling fan may operate for 2~5 minutes after cooking for safety.(the display will show "COOL" and ":0 ") Opening the door during cooking will cause the oven to shut off the cooking process and any displayed countdown to pause. When the **START/+30sec** button is pressed, the cooking countdown will resume. When the **STOP/Clear** button is pressed, the cooking is cancelled. The oven displays the set cooking time in 10 seconds steps (up to 5 minutes cooking time), in 30 seconds steps (up to 10 minutes cooking time), in 1 minutes steps (up to 60 minutes cooking time).

MICROWAVE COOKING

This microwave cooking method allows you to cook food for a desired time. In addition to the maximum power level(100%), you can select different microwave power from 9 other levels, 10% to 90% for the foods that require slower cooking. If you have used the appliance for grilling, convection or combination cooking, let the oven cool down before using again. Never switch the microwave oven on when it is empty.

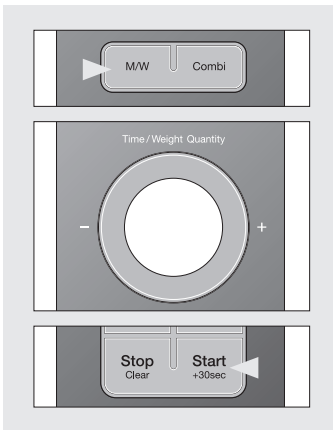

1. Press **M/W** button once. **M/W** indicator lights.
"P-HI" shows in display.
2. Select the appropriate power level by pressing the **M/W** button again until the corresponding percentage is displayed. Refer to the power level table below for further details.
3. Turn the **dial knob** to set the cooking time.
For a cooking time of 5 minutes 30 seconds, turn the **dial knob** to the right to set 5:30. (up to 60 minutes)
"5:30" shows in display.
4. Press **START/+30sec** button.
The oven light comes on and the turntable starts rotating.
Cooking starts and the time in the display will count down.

Note : The oven will automatically work on 100% microwave power if a cooking time is entered without the power level previously being selected.

You can check the power level while cooking is in progress by pressing the **M/W** button. The display will show the current power level for 2 seconds.

Power level table

Power level	percentage	Output	Power level	percentage	Output
P-HI	100%	900W	P-50	50%	450W
P-90	90%	810W	P-40	40%	360W
P-80	80%	720W	P-30	30%	270W
P-70	70%	630W	P-20	20%	180W
P-60	60%	540W	P-10	10%	90W
			P-00	0%	0W



GRILL COOKING

The grill enables you to heat and brown food quickly, without using microwaves.

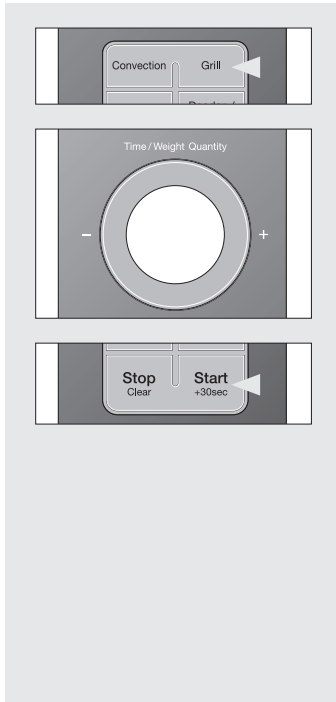

1. Press **Grill** button once. **Grill** indicator lights, and "0" is displayed.

2. Turn the **dial knob** to set the grilling time.

For a grilling time of 11 minutes, turn the **dial knob** to the right to set 11:00. (up to 60 minutes)

"11:00" shows in display.

3. Press **START/+30sec** button.

The oven light comes on and the turntable starts rotating. Cooking starts and the time in the display will count down.

Note :

The heating element is located in the top of the oven.

Note :

When first using the grill heaters, smoke and odour will be given off. To avoid this happening when food is being cooked, heat the upper and lower grills without food for approximately 10 minutes. Place food directly on the rack, in a flat dish or on a heat resistant plate on the rack.

WARNING :

The temperature inside the oven and window is very high. Do not touch the oven window and metallic interior of the oven when taking food out or putting it in the microwave. Use thick oven gloves while handling food or accessories.

Suggested use	Cookware
This method is ideal for toasting bread or muffins. Remember the oven will be hot. Place all food on metal rack.	Use oven-proof cookware. As there is no microwave energy being used you can place metal tins directly onto the metal rack with no danger of arcing.



CONVECTION COOKING (with pre-heat)

For convection cooking, it is recommended that you preheat the oven to the appropriate temperature before placing the food in the oven. (except for 40°C convection mode)

The maximum preheating time is 30 minutes. If the cooking is not started immediately after preheating, the convection indicator will continue to flash and the preheated oven temperature will be displayed.

It is maintained for 15 minutes; it is then switched off automatically.

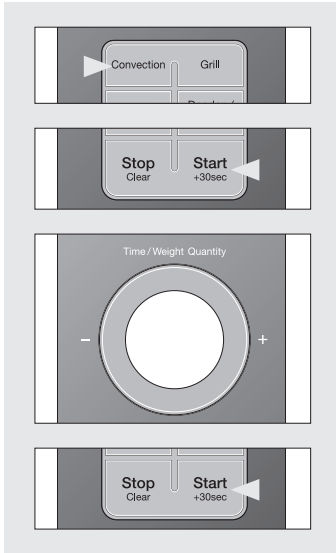

1. Press **Convection** button once. **Convection** indicator lights. "180C" shows in display.

2. Select the convection cooking temperature by pressing the **Convection** button again until the corresponding temperature is displayed.

Temperature sequence

180°C → 190°C → 200°C → 210°C → 220°C → 230°C →
240°C → 250°C → 110°C → 120°C → 130°C → 140°C →
150°C → 160°C → 170°C

3. Press **START/+30sec** button. **Convection** indicator flashes.

Temperature of preheating and "PRE-" blink alternatively in the display.

The oven will now preheat. When oven is preheated the oven will beep and the preheated oven temperature will appear in the display.

Then open the door and place your food in the oven.

Oven temperature shows in display.

4. Turn the **dial knob** to set the cooking time.

For a cooking time of 11 minutes, turn the **dial knob** to the right to set 11:00 (up to 60 minutes)

"11:00" shows in display.

5. Press **START/+30sec** button.

The oven light comes on and the turntable starts rotating.

Cooking starts and the time in the display will count down.

Note: You can check the setting temperature while cooking is in progress by pressing the **Convection** button.



CONVECTION COOKING (traditional cooking)

The convection mode enables you to cook food in the same way as in a traditional oven. Microwaves are not used. Always use oven gloves when touching the recipients in the oven, as they will be very hot.

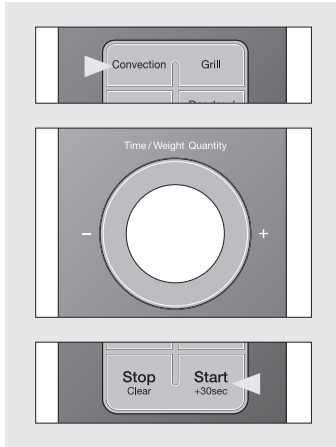

1. Press **Convection** button once. **Convection** indicator lights. "180C" shows in display.

2. Select the convection cooking temperature by pressing the **Convection** button again until the corresponding temperature is displayed.

Temperature sequence

180°C → 190°C → 200°C → 210°C → 220°C → 230°C →
240°C → 250°C → 40°C → 110°C → 120°C → 130°C →
140°C → 150°C → 160°C → 170°C

3. Turn the **dial knob** to set the cooking time.

For a cooking time of 11 minutes, turn the **dial knob** to the right to set 11:00. (up to 60 minutes)

"11:00" shows in display.

4. Press **START/+30sec** button.

The oven light comes on and the turntable starts rotating.

Cooking starts and the time in the display will count down.

Note: You can check the temperature setting while cooking is in progress by pressing the **Convection** button.

Suggested use	Cookware
<p>This function is ideal for cooking meringues, cookies, biscuits, scones, bread, puddings, large fruit cakes and all pastries. Remember the oven will be hot. Place all food on metal rack.</p>	<p>Use oven-proof cookware. As there is no microwave energy being used you can place metal tins directly onto the metal rack with no danger of arcing.</p>

Convection Cooking Recipe

Manual Cook Menu	Ingredients	Method
MINI SAUSAGE ROLL	store-bought puff pastry, 50g * 3, All-purpose flour, for dusting, sausages 50g *3, 1egg (beaten), freshly ground black pepper, thyme leaves, parsley	<ol style="list-style-type: none"> 1. Dust the work surface and place the puff pastry dough. 2. Place the sausages onto the dough. 3. Season with spices and pepper to your liking. 4. Roll the pastry and coat with beaten egg. 5. Cut into 6-8 pieces and place them into the fryer bowl. 6. Without preheating, cook for 20-25 minutes under 200°C until they turn golden brown.
ASPARAGUS AND SPINACH QUICHE	2 strips bacon(cut into 1 inch slices), 1/2 pound asparagus(trimmed, cleaned and cut into 1 inch pieces), 1 clove garlic(chopped), 1 green onions(sliced), 1 cups spinach, 3 eggs(lighty beaten), 1/2 cup milk, 1/2 cup gruyere(grated), salt and pepper to taste, 1 batch pastry dough(chilled)	<ol style="list-style-type: none"> 1. Set the dough onto a 9-inch pie plate and cut the excess off the rim. Use a fork to pierce holes and cook in the oven that has been preheated to 180°C for 10 minutes. 2. Slice the bacon into 1 inch pieces, cook and remove from the pan. Roast the asparagus in the same pan and add green onions. Finally add spinach and roast until they wilt. 3. Mix the egg, milk and grated gruyere cheese. 4. Add the cooked bacon and vegetables into the dough and pour in the egg mix. 5. Place the pie plate onto the metal rack and cook in an oven preheated to 190°C for 50-55 minutes.
CHICKEN POT PIE	<p>FOR THE PASTRY: 1cup all-purpose flour, 1tsp sugar, 1/4 tsp salt, 1/3 cup unsalted butter, 2-4 tbsp ice water</p> <p>For the filling: 300g chicken filets, 1cup chopped onion, 1cup chopped celery, 1 1/2cup chopped carrots, 1 garlic minced, 1/3cup all-purpose flour, 1 chicken bouillon cube, 4cup water</p>	<ol style="list-style-type: none"> 1. Making the dough: Using a food processor, mix flour, salt and sugar. Add diced butter and mix to create a fluffy texture. 2. Beat the dough into a lump by gradually adding ice water and let it rest in the refrigerator for over 1 hour. 3. Add 4 cups of water and 1 chicken bouillon cube into a pot and boil the chicken breasts. 4. Remove the chicken breasts and slice into thin slices. Filter any excess from the stock. 5. In a large pot, melt 3 table spoons of butter and roast onions, carrots and celery. Once done, add and roast the garlic and coat with flour. 6. Stir while gradually adding the stock, then, simmer until it thickens. 7. Season with salt and pepper. Add the sliced chicken and pour the filling into a 1.5 liter container. 8. Take out the dough from refrigerator and roll it until about 3mm thick. Cover the container with the dough and shape it by folding the edges inwards. Make a few, small gashes in the center. 9. Place the container onto the metal rack and cook in an oven preheated to 190°C for 50-55 minutes
MARGHERITA PIZZA	<p>FOR THE dough:300g strong bread flour, 1 tsp instant yeast (from a sachet or a tub), 1 tsp salt, 1 tbsp olive oil, plus extra for drizzling</p> <p>FOR THE TOMATO SAUCE:100ml passata, handful fresh basil or 1 tsp dried, 1 garlic clove(crushed),</p> <p>FOR THE TOPPING:125g ball mozzarella(sliced), handful grated or shaved parmesan, handful cherry tomatoes , halved handful basil leaves (optional)</p>	<ol style="list-style-type: none"> 1. Dough: Mix flour, yeast and salt in a bowl, then add olive oil and warm water. Beat until a smooth texture is gained. 2. Sauce: Mix basil and garlic into the passata. 3. Divide the dough in half. Roll it into a thin, circular shape. Then, place the dough onto a baking sheet or baking pan. Cover with the sauce. 4. Add toppings onto the sauce and evenly drizzle olive oil. 5. Place the pizza onto the metal rack and cook in an oven preheated to 200°C for 10-15 minutes.
BROWNIES	21cm cake mold, 150g dark chocolate, 50g milk chocolate, 90g unsalted butter, 80g brown sugar, 70g milk, 100g egg, 75g weak flour, 1/2 tsp baking powder, 60g chopped walnut FOR TOPPING hazelnut, coconut, walnut etc	<ol style="list-style-type: none"> 1. Chop the chocolates and melt in a pot on low heat. 2. Once melted, immediately move it to another bowl and stir with butter using a hand mixer at high speed. 3. Add sugar and warm milk, then mix. 4. Add the eggs in two steps and mix. 5. Sift the powder into the bowl and lightly mix. 6. Add ground walnuts and mix. 7. Lay oil paper on a pan and pour the mix. Add toppings and cook in an oven preheated to 160°C for approximately 40-45 minutes.



COMBINATION COOKING (Microwave + Convection + Upper Grill)

This function allows you to combine convection operation with microwave to produce traditional baked or roasted results in less time. Always use microwave-safe and oven-proof cookware. Glass or ceramic dishes are ideal as they allow the microwaves to penetrate the food evenly.

Always use oven gloves when touching the recipients in the oven, as they will be very hot.



1. Press **Combi** button once.
Combi indicator light and "**C-0**" will show in the display.

2. Select the desired power level.

For example : C-HI

Press **Combi** button once again "**C-HI**" will show in the display.

Display	MW Power
C - 0	40%
C - HI	50%
C - LO	30%

Note : In sequential operation mode, only "C-0" can be selected.

3. Press **Convection** button once.

"**180C**" shows in display.

Select the convection cooking temperature by pressing the **Convection** button again until the corresponding temperature is displayed.

Temperature sequence

180°C → 190°C → 200°C → 210°C → 220°C → 230°C →
240°C → 250°C → 110°C → 120°C → 130°C → 140°C →
150°C → 160°C → 170°C

4. Turn the **dial knob** to set the cooking time.

For a cooking time of 11 minutes, turn the **dial knob** to the right to set 11:00.
(up to 60 minutes)

"**11:00**" shows in display.

5. Press **START/+30sec** button.

The oven light comes on and the turntable starts rotating.

Cooking starts and the time in the display will count down.

Note : You can check the cooking temperature while cooking is in progress by pressing the **Convection** button.

The display will show the cooking temperature for 2 seconds.

In sequential operation mode, only "C-0" can be selected.



DEODORIZATION

You can use the Deodorization function to remove unpleasant smells from the microwave oven.



1. Press **Deodorization/Steam cleaning** button once.
The Deodorization indicator lights and "CL-1" is displayed.
The oven starts deodorizing for 5 minutes.

STEAM CLEANING (with Microwave Feature)

This function helps you to clean the inside of oven.



1. Put about 200ml water in a mug cup or small bowl in the middle of the tray in the oven.
2. Press the **Deodorization/Steam cleaning** button twice.
The **Steam Cleaning** indicator lights and "CL-2" is displayed.
The oven starts working immediately, and it works for 15 minutes.
3. The display shows "door" and "open" at 5 minute intervals if the operation has completed.
4. Open the door and wipe out the inner cavity with a dry cloth.



WEIGHT DEFROST

Weight Defrost automatically sets the defrosting times and power levels to give even defrosting results for frozen food. During the defrosting process the oven will beep to remind you to check the food. The oven will beep, open the door, turn the frozen food over and close the door, press the **START/+30sec** button.



1. Press **Defrost** button once. The **Defrost** indicator lights and remove spaces, it should be like this: "0" displayed. The "g" indicator blinks.
2. Turn the **dial knob** to set the weight.
Weight can be set up from 200g to 3000g.
The weight will change in 50g increments or decrements.
For a defrosting weight of 1000 grams, turn the **dial knob** to the right to set 1000. "1000" shows in display.
3. Press **START/+30sec** button.
The oven light comes on and the turntable starts rotating. The "g" indicator goes off.
Cooking starts and the time in the display will count down.
4. The oven will beep, open the door, turn the frozen food over and close the door, press the **START/+30sec** button.

Note : WEIGHT DEFROSTING, the defrosting time is automatically determined by the weight entered.

TIME DEFROST

During the defrosting process the oven will beep to remind you to check the food. The oven will beep, open the door, turn the frozen food over and close the door, press the **START/+30sec** button.

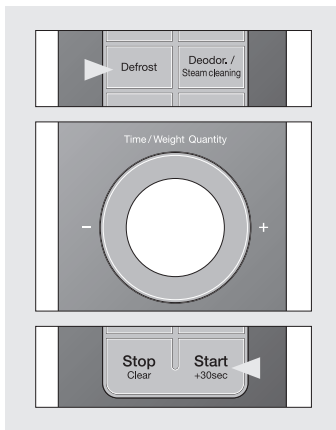

1. Press **Defrost** button twice.
The **Defrost** indicator lights and "0" is displayed.
2. Turn the **dial knob** to set the defrosting time.
For a time of 11 minutes, turn the **dial knob** to the right to set 11:00. (up to 60 minutes)
"11:00" shows in display.
3. Press **START/+30sec** button.
The oven light comes on and the turntable starts rotating.
Cooking starts and the time in the display will count down.
4. The oven will beep, open the door, turn the frozen food over and close the door, press the **START/+30sec** button.



HOME FRYER

Convenient function to set the temperature and cooking time automatically and simply by pressing **Home Fryer** button. Always use oven gloves when touching the recipients in the oven.

Please repeat the process from the top when you use the Home Fryer sequentially.

User can easily set the cooking time by adjusting the dial when Home Fryer menu 8 is selected.

Even while cooking is in progress, User can easily change the cooking time by adjusting the dial.



1. Select the menu by pressing **Home Fryer** button.
Auto Cook indicator light and "Fr-1" will show in the display.
2. Select the menu by pressing the **Home Fryer** button until the required menu is displayed.
Refer to the Home Fryer menu chart below for further details.
3. Set up the time by adjusting the **dial knob**.
ex) 10 minutes set up. (this function is only available in Home Fryer menu number 8)
4. Press the **START/+30sec** button.
The oven light comes on and the turntable starts rotating.
Cooking starts and the time in the display will count down.

Note : You can check the setting cooking menu while the cooking is in progress by pressing the **Home Fryer** button.

Home Fryer Menu Chart

Press home fryer key	Display	Home Fryer Menu	Turn Over	Start Temp.	Weight (g)	Time (min.)
Once	Fr-1	FROZEN POTATO CHIPS	-	Frozen	300g	20
Twice	Fr-2	BREADED CHICKEN BREAST	O	Frozen	400g	18
3 times	Fr-3	FISH FINGERS	O	Frozen	400g	17
4 times	Fr-4	CHICKEN NUGGETS	O	Frozen	400g	15
5 times	Fr-5	SPRING ROLL	O	Frozen	300g	13
6 times	Fr-6	ONION RING	O	Frozen	300g	13
7 times	Fr-7	CHEESE STICK	O	Frozen	400g	15
8 times	Fry	MANUAL COOK	O	-	-	Max. 30

NOTE

Please turn the food over before 4-5 minutes in advance if the food is needed to be turned over.

In order to cook the food more crispy, please increase the time by adjusting the dial.

A little bit of smell and fume can occur while operation the Home Fryer for the first time. It is not malfunction. Please use it in peace.

The cooling fan might be operated in order to decrease the inside temperature. It is not malfunction. Please use it in peace.

Manual Cooking Recipe

Manual Cook Menu	Ingredients	Method
HOMEMADE CHIPS	400-500g potatoes, 1 tbsp cooking oil, 1/4 tsp salt, 1/4 tsp paprika, pepper	<ol style="list-style-type: none"> 1. Cut the potatoes into 1cm thick slices and mix with cooking oil, salt, paprika and pepper. 2. Evenly spread the potatoes in the fryer bowl and cook with home fryer function for 28-30 minutes. Flip the potatoes over 8-12 minutes before finishing.
BREADED FISH FILLET	2 Fish filets (200g~250g), salt, pepper, 1 egg, 3 tbsp flour, 1 cup bread crumbs. (1.5 tbsp cooking oil) * Add cooking oil into bread crumbs and mix.	<ol style="list-style-type: none"> 1. Remove moisture from the fish using kitchen towels and season with salt and pepper. 2. Evenly coat the fish with flour, egg and bread crumb. Place it in the fryer bowl. 3. Cook with home fryer function for 17-19 minutes. Flip the food over 6-8 minutes before finishing. 4. Serve with sorrel sauce.



Manual Cook Menu	Ingredients	Method
POTATO CROQUETTES	400g potatoes, 50g ground cheddar cheese, 50g ground parmesan cheese, 2 chopped spring onions, 50g flour, salt, pepper, 2 eggs, 100g bread crumbs, cooking oil * Add cooking oil into bread crumbs and mix.	<ol style="list-style-type: none"> 1. Boil the potatoes for 20 minutes and mash after removing the skin. 2. Add cheese, 1 egg and spring onions and season with salt and pepper. 3. Shape the mix into oval shapes and coat with flour, beaten egg and bread crumbs respectively 4. Place the croquettes in the fryer bowl and cook with home fryer function for 16~18 minutes. Flip the food over 6~8 minutes before finishing.
CHICKEN KIEVES	2 Chicken breasts, 3 tbsp garlic & herb soft cheese, 1 cup bread crumbs, 1.5 tbsp cooking oil, 1/4 tsp garlic powder, 1/2 tsp parsley powder, 3 tsp flour, 1 egg.	<ol style="list-style-type: none"> 1. Mix bread crumbs with cooking oil, garlic powder and parsley. 2. Score into the sides of the chicken breasts make a pocket-like shape. 3. Fill the chicken breasts with cream cheese and coat with flour, beaten egg and bread crumbs respectively. Place it in the fryer bowl. 4. Cook with home fryer function for 17~19 minutes. Flip the food over 6~8 minutes before finishing.
BREADED CHICKEN FINGERS	2 Chicken breasts (250~300g), 2 cups cereal, 2 tbsp parmesan cheese, 1/4 tsp pepper, 2 tsp melted butter, 2 tsp mayonnaise	<ol style="list-style-type: none"> 1. Slice the chicken breasts into strips the width of your fingers and stir them with mayonnaise. 2. Fill a plastic bag with the cereal, parmesan cheese, pepper and melted butter. Then, crush the mix. 3. Put the chicken breasts into the plastic bag and coat them with cereal mix. Place it in the fryer bowl. 4. Cook with home fryer function for 11~13 minutes. Flip the food over 4~6 minutes before finishing.
FRIED CHICKEN WINGS	500g Chicken wings (separated at joints, tips discarded), salt, pepper, 1 tbsp hot sauce, 1/2~1 tsp cooking oil, 4 tbsp flour FOR SAUCE 1 tsp crushed garlic, 1.5 tsp ground ginger, 1 tsp chili sauce, 2 tbsp vinegar, 2 tsp brown sugar, 1 tsp soy sauce	<ol style="list-style-type: none"> 1. Remove moisture from the chicken wings after washing, then, mix with salt, pepper and hot sauce in a bowl. 2. Coat the chicken wings with flour in a plastic bag. Place them in the fryer bowl without overlapping. 3. Cook with home fryer function for 23~27 minutes. Flip the food over 7~9 minutes before finishing. 4. While the chicken wings are being cooked, mix the sauce ingredients and simmer. 5. Place the chicken in the sauce and mix to finish.
BANANA FRITTERS	2 large bananas FOR BATTER 6 tbsp weak flour, 1 tsp sugar, 1/4 tsp salt, 1/4 tsp baking powder, 50g coconut slice, 90g milk, 1 tsp grape seed oil	<ol style="list-style-type: none"> 1. Remove the skin from the bananas and slice them 2~2.5cm thick. 2. Mix the batter ingredients and let them settle for 5 minutes. Coat the bananas with the batter and place them in the fryer bowl. 3. Place the bowl in the oven and cook with home fryer function for 13~15 minutes. 4. Flip the food over 4~6 minutes before finishing.
COCONUT SHRIMP	15 shrimps (approx. 200g peeled and deveined), 2 tbsp starch, salt, pepper, 1 egg white, 1/2 cup bread crumbs, 1/2 cup flaked coconut, 1.5 tbsp cooking oil, 1/4 tsp paprika	<ol style="list-style-type: none"> 1. Skin the shrimps and remove moisture. 2. Add salt and pepper to the starch. Whisk the egg whites. Mix bread crumbs, coconut, cooking oil and paprika. 3. Coat the shrimps with the starch mix, whisked egg whites and bread crumbs respectively and place them in the fryer bowl. 4. Cook with home fryer function for 11~13 minutes. Flip the food over 4~6 minutes before finishing.
FRIED CALAMARI	2 squids (body part only, 150~200g), 1 tsp white wine, 1/4 tsp garlic powder, 3 tsp flour, 1 cup bread crumbs, 1.5 tbsp cooking oil, 1 tsp parsley powder, 1 egg, 1 tsp milk, pepper FOR TARTAR SAUCE, 1/2 cup mayonnaise, 2 tbsp chopped pickles, 1 tsp chopped onion, 1 tsp chopped caper, 2 tsp Dijon mustard, 1 tsp wholegrain mustard, 1 tsp lemon juice, 2-3 drops hot sauce, salt, pepper	<ol style="list-style-type: none"> 1. Remove squid's organs and slice into 1cm thick rings. 2. Marinate the squid in a bowl with white wine and garlic powder. 3. Mix the bread crumbs with chopped parsley. Mix milk and pepper into beaten egg. 4. Coat the marinated squid with flour, beaten egg and bread crumbs respectively and place it in the fryer bowl. 5. Cook with home fryer function for 16~18 minutes. Flip the food over 6~8 minutes before finishing. 6. Serve with tartar sauce.
FRIED MUSHROOM	14-15 button mushrooms (300g) FOR BATTER 2 tsp flour, 1 egg, 1 cup bread crumbs(1.5 tbsp cooking oil) *Add cooking oil into bread crumbs and mix. FOR SAUCE 2 tsp plain yogurt, 2 tsp mayonnaise, 1 tsp chopped onions, 1/4 tsp garlic, pepper, parsley	<ol style="list-style-type: none"> 1. Wash the button mushrooms. Put them inside a plastic bag with flour and shake. 2. Coat the mushrooms with beaten egg and bread crumbs respectively, then, place them in the fryer bowl. 3. Place the bowl in the oven and cook with home fryer function for 14~16 minutes. 4. Flip the food over 4~6 minutes before finishing. 5. While the mushrooms are being cooked, make the sauce. Serve mushrooms with said sauce.



AUTO COOK

This function allows you to simply and automatically cook a range of popular foods.
Always use oven gloves when touching the recipients in the oven.

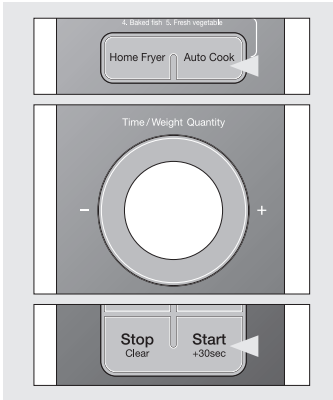

1. Press **Auto Cook** button once.
Auto Cook indicator light.
"AC-1" will show in the display.
2. Select the menu by pressing the **Auto Cook** button until the required menu is displayed.
Refer to the auto cook menu chart below for further details.
3. Turn the **dial knob** to set the cooking weight.
For a cooking weight of 1000 grams, turn the **dial knob** to the Right to set 1000 g (up to 2000 grams)
"1000" shows in display. "g" shows in display.
Refer to the auto cook menu chart below for further details.
4. Press **START/+30sec** button.
The oven light comes on and the turntable starts rotating.
Cooking starts and the time in the display will count down.

Note : You can check the setting cooking menu while the cooking is in progress by pressing the **Auto Cook** button.

Auto Cook Menu Chart

Press auto cook key	Display	Auto Cook Menu	Minimum Weight	Maximum Weight	Weight Step
Once	AC-1	ROAST PORK	500 g	2000 g	100 g
Twice	AC-2	ROAST BEEF	500 g	2000 g	100 g
3 times	AC-3	ROAST CHICKEN	800 g	2000 g	100 g
4 times	AC-4	BAKED FISH	300 g	900 g	100 g
5 times	AC-5	FRESH VEGETABLE	100 g	900 g	50 g

Auto Cook Menu	Start Temp.	Method	Cookware
ROAST PORK	Chilled temp.	1. Tie the joint into a neat shape. 2. Place the meat on the dish. 3. Brush with a little oil. 4. Place roasts fat-side down on the dish. 5. Cook on "AUTO COOK-ROAST PORK or ROAST BEEF". 6. Turn over when hearing the beep. 7. Remove from oven. Drain off any excess juices. 8. Stand for 10 minutes in foil before serving.	Micro and heat proof dish. (e.g Pyrex.) Metal rack
ROAST BEEF			
ROAST CHICKEN	Chilled temp.	1. Wash and dry chicken. Tie the legs loosely together with string. 2. Pierce the skin a couple of times just under the legs. 3. Brush butter mixture all over the chicken on the dish. 4. Place roasts breast-side down on the dish. 5. Cook on "AUTO COOK-ROAST CHICKEN". 6. Turn over when hearing the beep. 7. Remove from oven. Drain off any excess juices. Season with salt if required. Stand for 10 minutes in foil before serving.	Micro and heat proof dish. (e.g Pyrex.) Metal rack
BAKED FISH	Chilled temp.	1. All types of fresh fish(except battered or breadcrumbed fish) can be cooked whether whole, fillets or steaks. 2. Place the prepared fish in a buttered dish. 3. Season with salt and pepper, sprinkle with lemon juice and dot with butter. Do not cover dish. 4. Place on dish on the metal rack on the Metal Tray. 5. Cook on "AUTO COOK- BAKED FISH".	Micro and heat proof shallow dish. (e.g Pyrex.) Metal rack
FRESH VEGETABLES		1. Wash and trim. 2. Place prepared vegetables into a suitable sized container. 3. Sprinkle with 2-3 tbs. of water. 4. Cover with pierced cling film or a lid. 5. Place on dish on the turntable. 6. Cook on "AUTO COOK- FRESH VEGETABLES." * For best results cut vegetables into similar sized pieces.	Microproof dish. (e.g Pyrex.)



+30sec

The +30sec function allows the oven to be cooking immediately on full power.

The **+30sec** function has been pre-programmed to increase in increments of 30 seconds up to a maximum time of 5 minutes.



1. Press **START/+30sec** button.

The oven will be " : 30" is displayed. **M/W** indicator lights.

And the oven will start immediately. No need to press **START/+30sec** button.

The oven light comes on and the turn table starts rotating and the time in the display will count down in seconds.

TO STOP THE OVEN WHILE THE OVEN IS OPERATING

1. Open the door.
 - Oven stops operating.
 - You can restart the oven by closing the door and touching **START/+30sec** button.
2. Press the **STOP/Clear** button.
 - Oven stops operating.
 - If you wish to cancel the cooking settings, press the **STOP/Clear** button again.

STAND-BY POWER "0"

This function is used for saving energy.



To set Stand-by power "0" mode

1. Push the **STOP/CLEAR** button.
 - " : 0" appears in the display.
2. Press and hold the **STOP/CLEAR** button until display is turned off.
3. To cancel the stand-by power "0" mode, press and hold **ZERO ON** button until display is turned on.
 - The oven is again available for normal use.

ABNORMAL MESSAGE

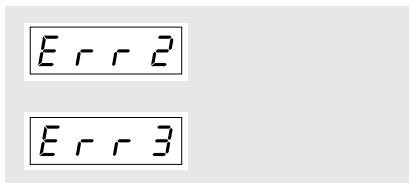

- If the inside temperature of the oven is higher than expected or the temperature sensor doesn't work properly, "**Err 2**" message will be shown in the display.
 - Unplug the power and call our technical service.
- When the temperature sensor is disconnected, "**Err 3**" message will be shown in the display.
 - Unplug the power and call our technical service.

WARNING

If you see arcing, press **STOP/Clear** button and correct the problem.

Arcing is the microwave term for sparks in the oven. Arcing is caused by:

- a) Metal or foil touching the side of the oven.
- b) Foil not molded to food (upturned edges act like antennas).
- c) Metal, such as twist-ties, poultry pins, or gold rimmed dishes, in the microwave.
- d) Recycled paper towels containing small metal pieces being used in the microwave.



GENERAL GUIDE LINES

Since microwave cooking to some extent is different from traditional cooking, the following general guidelines should be considered whenever you use your microwave oven

If the food is undercooked

Check if:

- You have selected the correct power level.
- The selected time is sufficient—the times given in the recipes are approximate. They depend on initial temperature, weight and density of the food etc.
- The container is appropriate.

If the food is overcooked, i. e. dried out or burnt

Before you cook again, consider whether:

- The power level was too high.
- The set time was too long—the times in the recipes are approximate. They depend on initial temperature, weight and density of the food etc.

Points to remember when defrosting

- The shape of the package alters the defrosting time.
- Shallow rectangular packets defrost more quickly than a deep block. Separate pieces as they begin to defrost; freef low slices defrost more easily.
- Shield areas of food with small pieces of foil if they start to become warm.
- When defrosting, it is better to under thaw the food slightly and allow the process to finish during the standing time.

The amount of food

The more food you want to prepare the longer it takes. A rule of thumb is that double amount of food requires almost double the time. If one potato takes four minutes to cook, approximately seven minutes are required to cook two potatoes.

Starting temperature of food

The lower the temperature of the food which is being put into the microwave oven, the longer time it takes. Food at room temperature will be reheated more quickly than food at refrigerator temperature.

Composition of the food

Food with a lot of fat and sugar will be heated faster than food containing a lot of water. fat and sugar will also reach a higher temperature than water in the cooking process. The more dense the food, the longer it takes to heat. "Very dense" food like meat takes longer time to reheat than lighter, more porous food like sponge cakes.

Size and shape

Smaller pieces of food will cook more quickly than larger pieces and uniform pieces of food cook more evenly than irregularly shaped foods.

With unevenly shaped food, the thinner parts will cook faster than the thicker areas. Place the thinner chicken wings and legs to the centre of the dish.

Stirring, turning of foods

Stirring and turning of foods are techniques used in conventional and well as in microwave cooking to distribute the heat quickly to the centre of the dish and avoid over-cooking at the outer edges of the food.

Covering food helps:

- To reduce spattering
 - To shorten cooking times
 - To retain food moisture
- All covering, which will allow microwaves to pass through are suitable—See above "Which utensils can be used in the oven?"

Releasing pressure in foods

Several foods are tightly covered by a skin or membrane. These foods should be pricked with a fork or cocktail stick to release the pressure and to prevent bursting, as steam builds up within them during cooking. This applies to potatoes, chicken livers, sausages, egg yolks and some fruits.

Standing time

Always allow the food to stand for some time after using the oven. standing time after defrosting, cooking/reheating always improves the result since the temperature will then be evenly distributed through out the food.

In a microwave oven foods continue to cook even when the microwave energy is turned off. They are no longer cooking by microwaves, but they are still being cooked by the conduction of the high residual heat to the centre of the food. The length of standing time depends on the volume and density of the food. Sometimes it can be as short as the time it takes you to remove the food from the oven and take it to the serving table. However, with larger, denser foods, the standing time may be as long as 10 minutes. During 'standing', the internal temperature of the food will rise by as much as 8°C and the food will finish cooking in this time.

Arranging food

This is done in several ways in microwave cooking to give more even cooking results.

If you are cooking several items of the same food such as jacket potatoes, place them in a ring pattern for uniform cooking. When cooking foods of uneven shapes or thickness, place the smaller or thinner area of the food towards the centre of the dish where it will be heated last.



Uneven foods such as fish should be arranged in the oven with the tails to the centre.

If you are saving a meal in the refrigerator or "plating" a meal for reheating, arrange the thicker, denser foods to the outside of the plate and the thinner or less dense foods in the middle.

Place thin slices of meat on top of each other or interlace them. Thicker slices such as meat loaf and sausages have to be placed close to each other. Gravy or sauce should be reheated in a separate container.



Choose a tall, narrow container rather than a low and wide container. When reheating gravy, sauce or soup, do not fill the container more than 2/3.



When you cook or reheat whole fish, score the skin this prevents cracking. Shield the tail and head with small pieces of foil to prevent over-cooking but ensure the foil does not touch the sides of the oven.





KEEP THE OVEN CLEAN

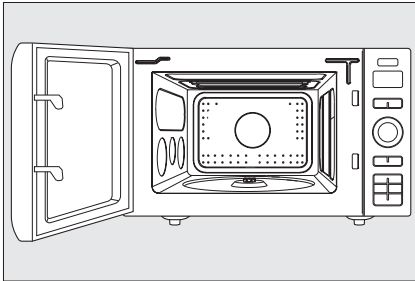

INSIDE THE OVEN

The interior three side walls and floor are stainless steel. For easy cleaning, wipe spills and splatters as they occur with a damp cloth or sponge with water and a mild detergent. Rinse the cavity of any cleaning residue with a clean damp or sponge after cleaning. Dry with a soft cloth.

These areas can also be cleaned by using plastic or nylon scouring pads recommended for use of Teflon and Silverstone*.

For hard to remove soil, use a mild non-abrasive cleaner. Use on the stainless steel areas, turntable and rotating base only.

TOP SURFACE

Two quartz grill elements are installed on the top surface. As they are fragile, be careful not to press or grip them hard. Do not remove the grill elements to clean the surface.

Warning

Just as your traditional oven becomes hot also this oven will become hot during use of the grill functions or in combination with microwaves. children should be supervised at all times when using the oven.

TURNTABLE AND ROTATING BASE

These two parts are easily removable for cleaning. The turntable should be cleaned frequently and is dishwasher proof. If food spills are accumulated under the rotating base, the oven will not operate efficiently. Be sure to wipe up any spills as they occur in this area.

Clean these parts as described in by the same method of cleaning inside the oven. Be sure to properly reinstall these parts into the cavity after cleaning.

Note:

Do not use any other Turntable in the oven. Do not operate the oven without the Turntable and Rotating Base Properly in place.

DOOR

While the oven door is still warm, any splatters or food soils should be wiped off with a damp sudsy cloth or sponge. Rinse with water and wipe dry with a cloth.

If steam or condensation appears around this area, wipe with a cloth. This may occur when the oven is operating under high humidity and with foods containing lots of moisture. This is a normal part of microwave cooking.

Note:

- Although your oven is provided with safety features, it is important to observe the following:
 1. It is important not to defeat or tamper with safety interlocks.
 2. Do not place any object between the oven front face and the door or allow residue to accumulate on sealing surfaces. Wipe the sealing area frequently with a mild detergent, rinse and dry. Never use abrasive powders or pads.
 3. When opened, the door must not be subjected to strain, for example, a child hanging on an opened door or any load could cause the oven to fall forward to cause injury and also damage to the door. Do not operate the oven if it is damaged, until it has been repaired by a service technician. It is particularly important that the oven closes properly and that there is no damage to the:
 - 1) Door(bent)
 - 2) Hinge and Hooks(broken or loosened)
 - 3) Door seals and sealing surface.
 4. The oven should not be adjusted or repaired by anyone except a properly competent service technician.
 5. The oven should be cleaned regularly and any food deposits removed;
 6. Failure to maintain the oven in a clean condition could lead to deterioration of the surface that could adversely affect the life of the appliance and possibly result in a hazardous situation;

EXTERIOR

CONTROL PANEL

Exercise care when cleaning this area. To clean, wipe the panel with a slightly dampened cloth, using only water. Wipe dry. Do not scrub this area or use any sort of chemical cleaner. Avoid use of excess water.

OUTSIDE SURFACE

The outside surfaces should be cleaned with soap and water, rinsed and dried with a soft cloth. Do not use any type of household or abrasive cleanser.

Note:

- DO NOT USE ANY TYPE OF OVEN CLEANER ON ANY PART OF THE OVEN. It will damage some of the interior and exterior surfaces of the oven.
- The oven should be cleaned regularly and any food deposits removed.
- Failure to maintain the oven in a clean condition could lead to deterioration of the surface that could adversely affect the life of the appliance and possibly result in a hazardous situation.



BEFORE CALLING FOR SERVICE

You can often correct operating problems yourself. If your microwave/grill oven fails to work properly, locate the operating problem in the chart below and try the solutions marked for each problems.

If the microwave/grill oven still does not work properly, contact the nearest Service Center.

Note:

It is quite normal for steam to be emitted around the door during the cooking cycle. The door is not intended to seal the oven cavity completely but its special design contributes to the complete safety of the appliance.

Caution:

1. Do not attempt to operate the oven while empty as this will cause damage.
2. As an exhaust is located in the rear of the oven, install the oven so as not to block the outlet.
If the microwave/grill oven still does not work properly, contact the nearest Service Center.

PROBLEM	1	2	3	4	5	6	7	8	9	10	11	12	13	14	15
Oven will not start	X	X	X	X											
Arcing or sparking					X	X									
Unevenly cooked foods					X		X	X	X						
Overcooked foods											X				
Undercooked foods					X					X	X	X			
Improper defrosting					X		X	X			X				X

SOLUTION	1	2	3	4	5	6	7	8	9	10	11	12	13	14	15
Is start button pressed?	Yes	Yes	Yes	Yes	No	No	No	No	No	No	No	No	No	No	No
Is power cord plugged in?	Yes	Yes	Yes	Yes	No	No	No	No	No	No	No	No	No	No	No
Is door closed?	Yes	Yes	Yes	Yes	No	No	No	No	No	No	No	No	No	No	No
Set the cooking time.	Yes	Yes	Yes	Yes	No	No	No	No	No	No	No	No	No	No	No
Use approved cookware only.	Yes	Yes	Yes	Yes	No	No	No	No	No	No	No	No	No	No	No
Do not operate with oven empty.	Yes	Yes	Yes	Yes	No	No	No	No	No	No	No	No	No	No	No
Supplied tray must be used.	Yes	Yes	Yes	Yes	No	No	No	No	No	No	No	No	No	No	No
Turn or stir food.	Yes	Yes	Yes	Yes	No	No	No	No	No	No	No	No	No	No	No
Completely defrost food.	Yes	Yes	Yes	Yes	No	No	No	No	No	No	No	No	No	No	No
Turn correct dial knob / Press correct Function buttons	Yes	Yes	Yes	Yes	No	No	No	No	No	No	No	No	No	No	No
Check to see that oven ventilation parts are not blocked.	Yes	Yes	Yes	Yes	No	No	No	No	No	No	No	No	No	No	No
Do "manual cooling" over 10 minutes.	Yes	Yes	Yes	Yes	No	No	No	No	No	No	No	No	No	No	No



QUESTIONS AND ANSWERS

*** Q : I accidentally ran my microwave oven without any food in it. Is it damaged?**

A : Running the oven empty for a short time will not damage the oven. However, it is not recommended.

*** Q : Can the oven be used with the tray or tray rack removed?**

A : No. Both the glass tray and roller guide must always be used in the oven before cooking.

*** Q : Can I open the door when the oven is operating?**

A : The door can be opened anytime during the cooking operation. Then microwave energy will be instantly switched off and the time setting will maintain until the door is closed.

*** Q : Why do I have moisture in my microwave oven after cooking?**

A : The moisture on the side of your microwave oven is normal. It is caused by steam from cooking food hitting the cool oven surface.

*** Q : Does microwave energy pass through the viewing screen in the door?**

A : No. The metal screen bounces back the energy to the oven cavity. The holes are made to allow light to pass through. They do not let microwave energy pass through.

*** Q : Why do eggs sometimes pop?**

A : When baking or poaching eggs, the yolk may pop due to steam build-up inside the yolk membrane. To prevent this, simply pierce the yolk with a toothpick before cooking. Never cook eggs without piercing their shells.

*** Q : Why this standing time recommended after the cooking operation has been completed?**

A : Standing time is very important.
With microwave cooking, the heat is in the food, not in the oven. Many foods build up enough internal heat to allow the cooking process to continue, even after the food is removed from the oven. Standing time for joints of meat, large vegetables and cakes is to allow the inside to cook completely, without overcooking the outside.

*** Q : What does "standing time" mean?**

A : "Standing time" means that food should be removed from the oven and covered for additional time to allow it to finish cooking. This frees the oven for other cooking.

*** Q : Why does my oven not always cook as fast as the microwave cooking guide says?**

A : Check your cooking guide again, to make sure you've followed directions exactly ; and to see what might cause variations in cooking time. Cooking guide times and heat settings are suggestions, to help prevent overcooking... the most common problem in getting used to a microwave oven.
Variations in the size, shape and weights and dimensions could require longer cooking time. Use your own judgement along with the cooking guide suggestions to check whether the food has been properly cooked just as you would do with a conventional cooker.

*** Q : Will the microwave oven be damaged if it operates while empty?**

A : Yes. Never run it empty.

*** Q : Can I operate my microwave oven without the turntable or turn the turntable over to hold a large dish?**

A : No. If you remove or turn over the turntable, you will get poor cooking results. Dishes used in your oven must fit on the turntable.

*** Q : Is it normal for the turntable to turn in either direction?**

A : Yes. The turntable rotates clockwise or counterclockwise, depending on the rotation of the motor when the cooking cycle begins.

*** Q : Can I pop popcorn in my microwave oven? How do I get the best results?**

A : Yes. Pop packaged microwave popcorn following manufacture's guidelines. Do not use regular paper bags. Use the "listening test" by stopping the oven as soon as the popping slows to a "pop" every 1 or 2 seconds. Do not repop unpopped kernels. Do not pop popcorn in glass cookware.



SPECIFICATIONS

Power supply		230V~, 50Hz
Microwave	Power consumption	1400W
	Output power	900W (IEC 705)
	Frequency	2,450MHz
Grill power consumption		2300W
Convection power consumption		2300W
Combination heating power consumption		2500W
Home fryer power consumption		2300W
Outside Dimension(WXDXH)		501(19.7) X 494(19.4) X 319(12.6)mm (inch)
Cavity Dimensions(WXDXH)		310(12.2) X 328(12.9) X 232(9.1)mm (inch)
Net Weight		Approx. 18.5Kg (40.7 lbs.)
Timer		60 minutes
Select function		Microwave / Grill / Convection / Combination / Home fryer
Microwave power level		10 stages

* Microwave oven is a Group 2 ISM equipment in which radio-frequency energy is intentionally generated and used in the form of electromagnetic radiation for the treatment of material. This oven is a Class B equipment suitable for use in domestic establishments and in establishments directly connected to a low voltage power supply network which supplies buildings used for domestic purposes.

* Specifications are subject to change without notice.

DISPOSAL OF USED ELECTRICAL & ELECTRONIC EQUIPMENT



The meaning of the symbol on the product, its accessory or packaging indicates that this product shall not be treated as household waste. Please, dispose of this equipment at your applicable collection point for the recycling of electrical & electronic equipments waste. In the European Union and Other European countries which there are separate collection systems for used electrical and electronic product. By ensuring the correct disposal of this product, you will help prevent potentially hazardous to the environment and to human health, which could otherwise be caused by unsuitable waste handling of this product. The recycling of materials will help conserve natural resources. Please do not therefore dispose of your old electrical and electronic equipment with your household waste. For more detailed information about recycling of this product, please contact your local city office, your household waste disposal service or the shop where you purchased the product.

COOKING INSTRUCTIONS

Only use utensils that are suitable for use in microwave ovens.

To cook food in the microwave oven, the microwaves must be able to penetrate the food, without being reflected or absorbed by the dish used.

Care must therefore be taken choosing the utensil. If the utensil is marked microwave-safe, you do not need to worry.

The following table lists various of utensil and indicates whether and how they should be used in a microwave oven.

Utensil	Safe	Comments
Aluminium foil	▲	Can be used in small quantities to protect areas against overcooking. Arcing can occur if the foil is too close to the oven wall or if too much foil is used.
Crust plate	●	Do not preheat for more than 8minutes.
China and earthenware	●	Porcelain, pottery, glazed earthenware and bone china are usually suitable, unless deco-rated with a metal trim.
Disposable polyester cardboard dishes	●	Some frozen foods are packaged in these dishes.
Fast-food packaging • Polystyrene cups containers • Paper bags or newspaper • Recycled paper or metal trims	● × ×	Can be used to warm food. Overheating may cause the polystyrene to melt. May catch fire. May cause arcing.
Glassware • Oven-to-table ware • Fine glassware • Glass jars	● ● ●	Can be used, unless decorated with a metal trim. Can be used to warm foods or liquids. Delicate glass may break or crack if heated suddenly. Must remove the lid. Suitable for warming only.
Metal • Dishes • Freezer bag twist ties	× ×	May cause arcing or fire.
Paper • Plates, cups, napkins and Kitchen paper • Recycled paper	● ×	For short cooking times and warming. Also to absorb excess moisture. May cause arcing.
Plastic • Containers • Cling film • Freezer bags	● ● ▲	Particularly if heat-resistant thermoplastic. Some other plastics may warp or discolour at high temperatures. Do not use Melamine plastic. Can be used to retain moisture. Should not touch the food. Take care when removing the film as hot steam will escape. Only if boilable or oven-proof. Should not be airtight. Prick with a fork, if necessary.
Wax or grease-proof paper	●	Can be used to retain moisture and prevent spattering.

● : Recommended use

▲ : Limited Use

× : Not Recommended

SERVICE CENTRES

If you have followed the instructions and still have a problem, contact the nearest Defy Service Centre. They will be able to advise you on any aspect of the product or send a qualified technician to repair it.

South African Service Agents:

BLOEMFONTEIN

160 Long Street, Hilton, Bloemfontein 9301
Tel: 051 400 3900
Bloemfontein.Service@defy.co.za

CAPE TOWN

5A Marconi Rd. Montague Gardens, 7441
Tel: 021 526 3000
CapeTown.Service@defy.co.za

DURBAN

35 Intersite Avenue, Umgeni Business Park,
Durban, 4051
Tel: 031 268 3300
Durban.Service@defy.co.za

EAST LONDON

16 Bowls Rd. Arcadia, East London, 5201
Tel: 043 743 7100
EastLondon.Service@defy.co.za

JOHANNESBURG

Cnr. Mimetes & Kruger Sts. Denver ext.12
Johannesburg, 2094
Tel: 011 621 0200 or 011 621 0300
Gauteng.Service@defy.co.za

POLOKWANE

87 Nelson Mandela Drive, Superbia 0699
Tel: 0152 92 1166 / 7 / 8 / 9
Polokwane.Service@defy.co.za

PORT ELIZABETH

112 Patterson Road, North End, Port Elizabeth
6001
Tel: 041 401 6400
PortElizabeth.Service@defy.co.za

PRETORIA

Block A1 Old Mutual Industrial Park,
Cnr. D.F.Malan Drive & Moot Str. Hermanstad,
0082
Tel: 012 377 8300
Pretoria.Service@defy.co.za

Sub-Saharan Africa Service Agents:

ZAMBIA: SOUTHGATE INVESTMENTS LTD

Plot 1606, Sheki Sheki Road
P.O. Box 33681
Lusaka, 10101, Zambia
Tel: +260 0211 242332/3
Fax: +260 0211 242933
sgiservicecentre@microlink.zm

NAMIBIA: ATLANTIC DISTRIBUTORS (PTY) LTD

10 Tienie Louw Street, Northern Industrial Area
P.O. Box 21158, Windhoek, Namibia
Tel: (061) 216162
Fax: (061) 216134
atlantic@mweb.com.na

ZIMBABWE: TRADECOMAFRICA

Trade Com Africa, 183 Loreley Crescent
Msasa, Harare, Zimbabwe
Tel: +263 4 486165/6
Cell: +263 772 469010
Cell: +263 772 469011

BOTSWANA: RAY MORGAN AGENCIES

RMA Service Centre, Plot 48, East Gate
Gaborone International Commerce Park
Kgale View, Gaborone
Botswana
Tel: +267 390 3996 / 390 3912
Fax: +267 318 7376
Cell: +267 7134 6539
service@rma.co.bw; raja@rma.co.bw

SWAZILAND: LYNDS DISTRIBUTORS

P.O Box 716, Mbabane, Swaziland, H100
Tel: (00268) 2515 4310/8
Fax: (00268) 2518 4318

MOZAMBIQUE: COOL WORLD. LDA

Rua da Resistencia No. 97B R/C
Cell: +258 84 44 61 234
coolworldlda@hotmail.com
Nosso Show Room
Av: da Industrias, Parcela No.735 * 735A
Machava, Maputo

**OTHER AREAS ARE SERVICED BY OVER 200 AUTHORISED SERVICE AGENTS.
PLEASE CONSULT THE NEAREST REGIONAL DEFY SERVICE CENTRE FOR DETAILS.**

WARRANTY

- 1 This certificate is issued by DEFY APPLIANCES (PTY) LIMITED manufacturers of Defy and Ocean products, hereinafter the Company, to the original purchaser only, of the appliance described on the certificate and shall constitute the only warranty given in respect of this appliance.
- 2 The Company warrants to the original purchaser that for a period of TWO YEARS from date of purchase the appliance is free from defect under normal domestic use, both in workmanship and material, subject to the following conditions.
- 3 Repair or replacement of any part of this appliance, found by the Company to be defective, shall be at the election of the Company. The Company reserves the right to effect such service through any of its Service Divisions or Authorised Service Dealers. The cost of such service shall be borne by the Company in full, provided that the appliance is located no further than 50 km from a Company Service Centre or an Authorised Service Dealer. Where the appliance is located beyond the 50 km radius, the purchaser shall be liable for the standard travelling charges, as determined by the Company.
- 4 **Carry-in service. Microwave ovens are repaired in our service centres and are not collected from the customers home. Faulty units should be delivered to the purchasing dealer or to the nearest Company Service Centre for warranty repairs.**
- 5 Rusted or corroded plates, vitreous enamelware, fuses and lamps are specifically excluded from these warranties. It is an express condition of these warranties that the purchaser takes due care and attention in the use and maintenance of the appliance. Abuse, misuse in conflict with operating instructions, connection to incorrect voltages and subjection to commercial use shall release the Company from its obligations.
- 6 This warranty shall become void and cease to operate if the appliance is dismantled by, or any repairs to the appliance are effected by any persons not duly authorised by the Company, or if substitute parts not approved by the Company are used in the appliance, or if the serial number of the appliance is removed.
- 7 The Company shall not be responsible for damages resulting from fire, flood, civil disturbances or any Act of God. The Company shall not, in terms of these warranties be responsible nor held liable for any consequential loss or damage of any kind caused by or due to the failure or malfunction of the appliance.
- 8 The Company shall not be responsible for transportation or other costs other than those incurred within the provisions of Point 1 of this Certificate.
- 9 **For warranties in the Republic of South Africa and Sub-Saharan Africa, please contact your nearest Defy office. Please refer to the previous page for respective South African service agents and Sub-Saharan Africa service agents.**
- 10 Where service is requested under warranty and no fault or defect can be found by the Company, all costs incurred will be for the purchaser's account.
- 11 This Certificate as well as your invoice will serve as proof of purchase. For the purpose of warranty, it will be essential to produce this Certificate and invoice. Failure to do so, will render the purchaser liable for service costs.

**KEEP THIS CERTIFICATE AND SALES INVOICE AS PROOF OF
PURCHASE FOR WARRANTY PURPOSES.**

Free Manuals Download Website

<http://myh66.com>

<http://usermanuals.us>

<http://www.somanuals.com>

<http://www.4manuals.cc>

<http://www.manual-lib.com>

<http://www.404manual.com>

<http://www.luxmanual.com>

<http://aubethermostatmanual.com>

Golf course search by state

<http://golfingnear.com>

Email search by domain

<http://emailbydomain.com>

Auto manuals search

<http://auto.somanuals.com>

TV manuals search

<http://tv.somanuals.com>