



SHELLEYBASIC BY DELFIELD

Service, Installation and Care Manual

Please read this manual completely before attempting to install or operate this equipment!
Notify carrier of damage! Inspect all components immediately. See page 2.



 **CAUTION**
IMPORTANT INFORMATION
READ BEFORE USE
PLEASE SAVE THESE INSTRUCTIONS!

Effective Date June 2008
Enodis®

Contents

Serial Number Information.....	2
Receiving And Inspecting The Equipment.....	2
Specifications	3-4
Installation	5
Operation.....	6-7
Reversing And Replacing Panels.....	7
Maintenance.....	8
Wiring Diagrams.....	9-12
Replacement Parts.....	13-16
Standard Labor Guidelines.....	17
Standard Warranties.....	18
Notes	19

Serial Number Information

The serial number on self-contained refrigerated units is on the electrical specifications tag located near the condensing unit.

On hot food pans and hot/cold combination pans, the serial number tag is located on the bottom shelf of the cabinet.

The serial number tag also lists the refrigerant used and the amount of charge.

Always have the serial number of your unit available when calling for parts or service. A complete list of authorized Delfield parts depots is available at www.delfield.com.

©2008 The Delfield Company. All rights reserved. Reproduction without written permission is prohibited. Delfield is a registered trademark of The Delfield Company.

Receiving And Inspection The Equipment

Even though most equipment is shipped crated, care should be taken during unloading so the equipment is not damaged while being moved into the building.

1. Visually inspect the exterior of the package and skid or container. Any damage should be noted and reported to the delivering carrier immediately.
2. If damaged, open and inspect the contents with the carrier.
3. In the event that the exterior is not damaged, yet upon opening, there is concealed damage to the equipment notify the carrier. Notification should be made verbally as well as in written form.
4. Request an inspection by the shipping company of the damaged equipment. This should be done within 10 days from receipt of the equipment.
5. Check the lower portion of the unit to be sure legs or casters are not bent.
6. Also open the compressor compartment housing and visually inspect the refrigeration package. Be sure lines are secure and base is still intact.
7. Freight carriers can supply the necessary damage forms upon request.
8. Retain all crating material until an inspection has been made or waived.

Uncrating the Equipment

First cut and remove the banding from around the crate. Remove the front of the crate material, use of some tools will be required. If the unit is on legs remove the top of the crate as well and lift the unit off the skid. If the unit is on casters it can be "rolled" off the skid.

Specifications

Shelleybasic by Delfield Heated Counters

Model	L	D	H	Ship Wt	Food Wells	Volts	Plug	Amp
SE-H2	39"	29"	36"	215lbs (98kg)	2	120/208-230	14-20P	10.0/11.0
SE-H3	50"	29"	36"	265lbs (120kg)	3	120/208-230	14-20P	15.0/16.0
SE-H4	64"	29"	36"	320lbs (145kg)	4	120/208-230	14-30P	20.0/22.0
SE-H5	78"	29"	36"	410lbs (186kg)	5	120/208-230	14-50P	24.0/27.0
SE-H6	92"	29"	36"	500lbs (227kg)	6	120/208-230	14-50P	29.0/32.0

Shelleybasic by Delfield Refrigerated Cold Pan Serving Counters

Model	L	D	H	Ship Wt	12 X 20 Pans	Volts	Plug	Amp	H.P.	Ref Chrg.	BTU Load	Sys. Cap.	Evap BTU/ TD/Temp
SE-C2	39"	29"	36"	340lbs (154kg)	2	115	5-15P	4.0	1/5	8.0 oz	379	812	26/31°/4°
SE-C3	50"	29"	36"	415lbs (188kg)	3	115	5-15P	4.0	1/5	8.0 oz	569	889	35/26°/9°
SE-C4	64"	29"	36"	490lbs (222kg)	4	115	5-15P	7.0	1/4	12.0 oz	758	1373	43/32°/3°
SE-C5	78"	29"	36"	565lbs (256kg)	5	115	5-15P	7.0	1/4	12.0 oz	948	1469	51/29°/6°
SE-C6	92"	29"	36"	640lbs (290kg)	6	115	5-15P	7.0	1/3	16.0 oz	1138	1921	59/32°/3°

Shelleybasic by Delfield Hot / Cold Self-Contained Combination Counters

Model	L	D	H	Ship Wt	12 X 20 Pans	Volts	Plug	Amp	H.P.	Ref Chrg.	BTU Load	Sys. Cap.	Evap BTU/ TD/Temp
SE-HC2	39"	29"	36"	350lbs (159kg)	2	120	5-30P	24.0	1/4	8.0 oz	379	1112	26/42°/-7°
SE-HC3	50"	29"	36"	425lbs (193kg)	3	120/240	14-30P	21.0	1/4	8.0 oz	569	1259	35/36°/-1°
SE-HC4	64"	29"	36"	500lbs (227kg)	4	120/240	14-30P	21.0	1/4	12.0 oz	758	1373	43/32°/3°
SE-HC5	78"	29"	36"	575lbs (261kg)	5	120/240	14-60P	42.0	1/4	12.0 oz	948	1469	51/29°/6°
SE-HC6	92"	29"	36"	650lbs (295kg)	6	120/240	14-60P	42.0	1/3	16.0 oz	1138	1787	59/30°/5°

Shelleybasic by Delfield Ice Cooled Serving Counters

Model	L	D	H	Ship Wt	12 X 20 Pans
SE-I2	39"	29"	36"	200lbs (91kg)	2
SE-I3	50"	29"	36"	245lbs (111kg)	3
SE-I4	64"	29"	36"	280lbs (127kg)	4
SE-I5	78"	29"	36"	330lbs (150kg)	5
SE-I6	92"	29"	36"	380lbs (172kg)	6

Shelleybasic by Delfield Frost Top Counters

Model	L	D	H	Ship Wt	Volts	Plug	Amp	H.P.	Ref Chrg.	BTU Load	Sys. Cap.	Evap BTU/ TD/Temp
SE-F2	39"	29"	36"	370lbs (168kg)	115	5-15P	7.5	1/4	24.0 oz	379	1112	26/42°/-7°
SE-F3	50"	29"	36"	445lbs (202kg)	115	5-15P	7.5	1/4	24.0 oz	569	1259	35/36°/-1°
SE-F4	64"	29"	36"	530lbs (240kg)	115	5-15P	7.5	1/4	24.0 oz	758	1373	43/32°/3°
SE-F5	78"	29"	36"	600lbs (272kg)	115	5-15P	8.0	1/4	24.0 oz	948	1469	51/29°/6°
SE-F6	92"	29"	36"	670lbs (304kg)	115	5-15P	8.0	1/3	24.0 oz	1138	1787	59/30°/5°

SES model specifications are the same as SE model specifications, except SES model height is 30".



Specifications continued

Shelleybasic by Delfield Utility Counters

<i>Model</i>	<i>L</i>	<i>D</i>	<i>H</i>	<i>Ship Wt</i>
SE-U2	39"	29"	36"	150lbs (68kg)
SE-U3	50"	29"	36"	170lbs (77kg)
SE-U4	64"	29"	36"	200lbs (91kg)
SE-U5	78"	29"	36"	230lbs (104kg)
SE-U6	92"	29"	36"	280lbs (127kg)

Shelleybasic by Delfield Cashier's Stand

<i>Model</i>	<i>L</i>	<i>D</i>	<i>H</i>	<i>Ship Wt</i>
SE-CS	29"	29"	36"	170lbs (77kg)

Shelleybasic by Delfield Tray Stand

<i>Model</i>	<i>L</i>	<i>D</i>	<i>H</i>	<i>Ship Wt</i>
SE-TS	39"	29"	36"	140lbs (64kg)

Shelleybasic by Delfield Ice Cream Counters - 0 degree only

<i>Model</i>	<i>L</i>	<i>D</i>	<i>H</i>	<i>Ship Wt</i>	<i>Cabinet Capacity</i>	<i>Volts</i>	<i>Plug</i>	<i>Amp</i>	<i>H.P.</i>	<i>Ref Chrg.</i>	<i>BTU Load</i>	<i>Sys. Cap.</i>	<i>Evap BTU/TD/Temp</i>
SE-ICE1	39"	29"	36"	460lbs (209kg)	84 cups	115	5-15P	5.3	1/4	7.0 oz	292	569	20/28°/-31°
SE-ICE2	50"	29"	36"	505lbs (229kg)	224 cups	115	5-15P	5.3	1/4	9.0 oz	473	661	28/24°/-24°

Shelleybasic by Delfield Corner Units

<i>Model</i>	<i>L</i>	<i>D</i>	<i>H</i>	<i>Ship Wt</i>
SE-29	29"	29"	36"	110lbs (50kg)
SE-39	39"	29"	36"	160lbs (73kg)

SES model specifications are the same as SE model specifications, except SES model height is 30".

Installation

Location

Units represented in this manual are for indoor use only. Be sure the location chosen has a floor strong enough to support the total weight of the cabinet and contents. A fully loaded model may weigh as much as 3000 pounds! Reinforce the floor as necessary to provide for maximum loading.

For the most efficient refrigeration, be sure to provide good air circulation inside and out. Be sure that the exterior of the unit has access to ample air. Avoid hot corners and locations near stoves and ovens. It is suggested the rear of the unit be no less than two inches from any wall, partition or any other object which will restrict exhaust air flow.



Unit requires that the sides and bottom are not any closer than 3" to any combustible material.

Leveling

A level cabinet looks better and will perform more efficiently when the doors line up with the door frames properly, the cabinet will not be subject to undue strain and the corners of the shelves will not move around on the supports. A level heated unit will maintain an equal water depth when water is used in the wells. Use a level to make sure the unit is level from front to back and side to side.

Stabilizing

All models are supplied on casters for your convenience, ease of cleaning underneath and for mobility.



The unit must be installed in a stable condition with the front wheels locked, locking the front casters after installation is the owner's responsibility.

Plumbing

Refrigerated units have a drain that exits the unit on the bottom and is located on the operator's left side. Standard units on casters or legs will have a bronze gate valve that fits a standard garden hose. Drain connections are on the operator side below the pan in the open shelf area.



Moisture collecting from improper drainage can create a slippery surface on the floor and a hazard to employees. It is the owner's responsibility to provide a container or outlet for drainage.

Electrical Connection

A standard unit is provided with a power cord and grounded plug.

The unit should be plugged into a receptacle with its own circuit protection that matches the amperage of the plug.



Connections must be made in accordance with all applicable local codes and/or the National Electrical Code. Refer to the amperage data on pages 3-4 and the wiring diagrams on pages 9-12 to be sure the unit is connected to the proper power source. A protected circuit of the correct voltage and amperage must be run for connection of the line cord.



On cord-connected units, the ON/OFF switch must be turned to its OFF position and power supply disconnected whenever doing the following:

- 1. Performing maintenance functions.**
- 2. Cleaning the refrigerated cabinet area.**
- 3. Performing service or repair functions.**

Under no circumstances should a refrigerated unit be operated without the louvered panel in place.

Operation SE-C And SES-C

There is a switch on the right side of the compressor stand used to turn the unit on and off.

These units are designed to hold cold food product between 33°F to 41°F (0.6°C to 5°C).

Cold pans are adjusted at the factory to provide satisfactory operation without any further adjustments. However, if it is necessary to adjust the temperature, the control is located in the machine compartment. Turn the knob clock-wise as indicated on the control. Settings are from 1 through 7; 7 being the coldest. Adjustments should be made gradually. Several small adjustments will be more effective than one large adjustment. It may take an hour or longer to realize the temperature change depending on the application and location of the unit.

These units are not designed to cool warm food products. Items should be placed in the unit pre-cooled at least to the desired holding temperature, if not slightly colder. In some applications, a gradual warming of product may occur, particularly at the exposed top of the product. Stirring or rotation of the product may be necessary to maintain overall temperature. Warming of food product can occur very quickly outside of the unit. When loading or rotating product, avoid leaving food items in a non-refrigerated location to prevent warming or spoilage.

When the cold pan is used with ice, use perforated bottoms. These will allow ice to melt properly.

The unit must be turned off when not in use or overnight for defrosting and cleaning.

Operation SE-H And SES-H

These units are designed to hold warm food product between 140°F to 160°F (60°C to 71°C).

Individually heated hot food units may be operated “wet” (with water in the wells) or “dry”. However, “wet” operation is recommended for better performance.

After plugging in the power supply cord, select desired temperature by rotating temperature control. A knob and indicator light are provided for each individual heated food well.

First Time Use

Before the unit is used the first time for serving, turn the temperature knob to **HI** and heat the well for 20 to 30 minutes. Any residue or dust that adhered to the heater element(s) will be burned off during this initial preheat period.

When serving thick sauces always operate the hot food well in “wet” operation. This provides more uniform temperature for the sauce.



Never place food directly in well. Always use pans.

NOTE

For most efficient operation, keep covered insets in each well during preheating or when empty.

Always place covers on pans when not serving to prevent food from drying out.

Wet Operation

Fill the food well with about 2” of water and cover with lid or empty pan. To preheat water, set temperature control at **HI**. With pans in place, wells will boil water. Food temperature will vary depending on type and amount of product. To minimize steam and water usage, set control to lowest setting that will maintain proper food temperature. To reduce preheating time, use hot water to fill the well.



NOTE

When operating these units “wet”, never use anything other than plain water in the wells or tank. Failure to observe this warning may result in personal injury or damage to the unit.



DANGER

When operated at the highest temperature setting, the top of the unit will become very hot. Staff and customers using the equipment should be informed about this.



DANGER

Steam can cause serious burns. Always wear some type of protective covering on your hands and arms when removing lids from the unit. Lift the lid in a way that will direct escaping steam away from your face and body.

Dry Operation

Wet operation is usually much more efficient and is preferred. However, these units may be operated without water with no damage to the unit.

When operated dry, the bottom of the well will discolor. To clean, use a stainless steel cleaner or mild abrasive.



CAUTION

The dry well should never be preheated longer than 15 minutes.



DANGER

When operated dry, the well bottoms become very hot. Do not allow unprotected skin to contact any well surface.

Operation SE-F And SES-F

Frost tops are designed to maintain an even layer of frost to pleasantly display desserts and pies. Once turned on, the compressor will run continuously. The unit should be turned off overnight or when not in use.

Since it takes time for frost to accumulate initially, the unit should be turned on approximately an hour before it is actually required. Product should not be placed on the frost top prior to turning the unit on, because it may freeze to the surface of the unit.

Operation SE-HC And SES-HC

The hot and cold combination pans must be operated with water in the well.

Hot Operation

Fill well with a minimum of 4" of water. Place function switch in **HOT** position. Turn thermostat dial to highest position and allow unit to warm up. Then reset the thermostat to maintain the desired temperature.



Never use anything more than plain water in the wells or tank. Failure to observe this warning may result in personal injury or damage to the unit.



When operated at the highest temperature setting, the top of the unit will become very hot. Staff and customers using the equipment should be informed about this.

To turn unit off, simply move the function switch to **OFF** position. Drain water and allow unit to cool before cleaning or switching to cold operation.

Cold Operation

Simply place the function switch to the **COLD** position. The compressor controller has been factory set and no temperature adjustment should be necessary. When the cold pan is used with ice, use perforated bottoms. These will allow ice to melt properly.

Switching from Hot to Cold Operation

Follow the following procedure:

- 1) Place the function switch in the **OFF** position and drain off hot water.
- 2) Allow the unit to cool until it can be safely cleaned.
- 3) When clean up procedures are complete, unit will be ready for cold operation.



To assure maximum compressor life, do not switch from "hot" to "cold" operation without allowing a cool down period. Never switch from hot to cold operation while hot water remains in the pans. Failure to observe this warning will greatly reduce compressor life and eventually cause premature compressor failure.

Switching from Cold to Hot Operation

No special procedure is required to switch from cold to hot operation. Be sure to fill with a minimum of 4" of water.



This unit is designed so that the compressor and the heating elements cannot operate at the same time. Continued operation of the compressor in the "hot position" should not be considered normal. Call for service if this happens.

The unit must be turned off when not in use or overnight for defrosting and cleaning.

Reversing And Replacing Panels

Shelleybasic laminated panels are reversible. All panels are replaceable. The panels sit in an upper and lower track.

Remove first an end panel. Gain access from the back of the unit. Place one hand inside the unit on the panel, and one hand on the panel outside the unit. Push the panel out and lift the panel up. Remove the panel from the lower track and then the upper track. By removing an end panel first you will have better access to the front panel. Repeat the process for the front panel and the other end panel.

Remove the panel from the upper track. Continue placing the panel into the unit and lower it into the lower track.

Maintenance

Drain Maintenance - Base

Each unit has a drain located inside the unit that removes the condensation from the evaporator coil and routes it to an external condensate evaporator pan. Each drain can become loose or disconnected during normal use. If you notice water accumulation on the inside of the unit be sure the drain tube is connected to the evaporator drain pan. If water is collecting underneath the unit make sure the end of the drain tube is in the condensate evaporator in the machine compartment. The leveling of the unit is important as the units are designed to drain properly when level. Be sure all drain lines are free of obstructions.

Caster Maintenance

Wipe casters with a damp cloth monthly to prevent corrosion.



The power switch must be turned to OFF and the unit disconnected from the power source whenever performing service, maintenance functions or cleaning.

Stainless Steel Care and Cleaning

To prevent discoloration or rust on stainless steel several important steps need to be taken. First, we need to understand the properties of stainless steel. Stainless steel contains 70-80% iron, which will rust. It also contains 12-30% chromium, which forms an invisible passive film over the steel's surface, which acts as a shield against corrosion. As long as the protective layer is intact, the metal is still stainless. If the film is broken or contaminated, outside elements can begin to breakdown the steel and begin to form discoloration or rust. Proper cleaning of stainless steel requires soft cloths or plastic scouring pads.

NEVER USE STEEL PADS, WIRE BRUSHES OR SCRAPERS!

Cleaning solutions need to be alkaline based or non-chloride cleaners. Any cleaner containing chlorides will damage the protective film of the stainless steel. Chlorides are also commonly found in hard water, salts, and household and industrial cleaners. If cleaners containing chlorides are used be sure to rinse repeatedly and dry thoroughly. Routine cleaning of stainless steel can be done with soap and water. Extreme stains or grease should be cleaned with a non-abrasive cleaner and plastic scrub pad. Always rub with the grain of the steel. There are stainless steel cleaners available which can restore and preserve the finish of the steels protective layer. Early signs of stainless steel breakdown are small pits and cracks. If this has begun, clean thoroughly and start to apply stainless steel cleaners in attempt to restore the passivity of the steel.



Never use an acid based cleaning solution! Many food products have an acidic content, which can deteriorate the finish. Be sure to clean the stainless steel surfaces of ALL food products. Common items include, tomatoes, peppers and other vegetables.

Cleaning the Condenser Coil

In order to maintain proper refrigeration performance, the condenser fins must be cleaned of dust, dirt and grease

regularly. It is recommended that this be done at least every three months. If conditions are such that the condenser is totally blocked in three months, the frequency of cleaning should be increased. Clean the condenser with a vacuum cleaner or stiff brush. If extremely dirty, a commercially available condenser cleaner may be required.

Failure to maintain a clean condenser coil can initially cause high temperatures and excessive run times. Continuous operation with a dirty or clogged condenser coil can result in compressor failure. Neglecting the condenser coil cleaning procedures will void any warranties associated with the compressor and cost to replace the compressor.



Never use a high-pressure water wash for this cleaning procedure as water can damage the electrical components located near or at the condenser coil.



Units with pans should be operated with pans in place. Operating the unit without all pans in place will lower efficiency and may damage the unit.

Defrosting

Refrigerated cold pans and frost tops should be defrosted daily. Ice Cream counters require defrosting after 3/8 to 1/2 of frost forming. Frost top **ON/OFF** switch is located in machine compartment. Cold pan thermostat has an **OFF** position.

Never use sharp objects or tools to clean or scrape ice/frost build up from the refrigerated cold pans or frost tops. A puncture to the pan could cause irreparable damage to the refrigeration system.

Over shelves and other items mounted to the top of the counters should never be installed in the field due to the potential damage to the refrigeration system.

Plexiglas Food Shield Cleaning

Wet a clean cloth with lukewarm water and dishwashing liquid. Apply only light pressure, rinse with clear and blot dry with a damp chamois. For excessively dirty surfaces, rinse surface dirt off before washing. Fine scratches will disappear when you polish by hand with a plastic cleaner polish.



Never use window sprays, kitchen scouring compounds or solvents such as acetone, gasoline, benzene, alcohol, carbon tetrachloride or lacquer thinner to clean plexiglas.

Wiring Diagram SE-C, SES-C, SE-ICE1, SES-ICE1, SE-ICE2, SES-ICE2

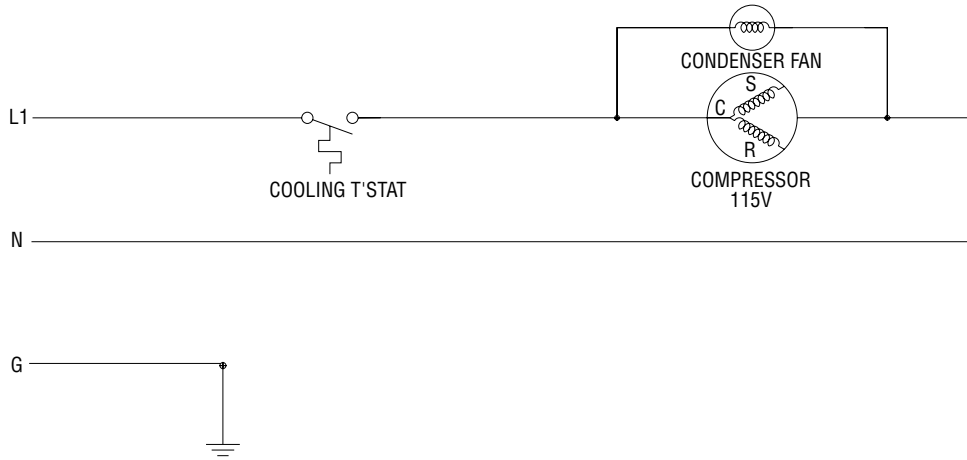

Wiring Diagram SE-F, SES-F

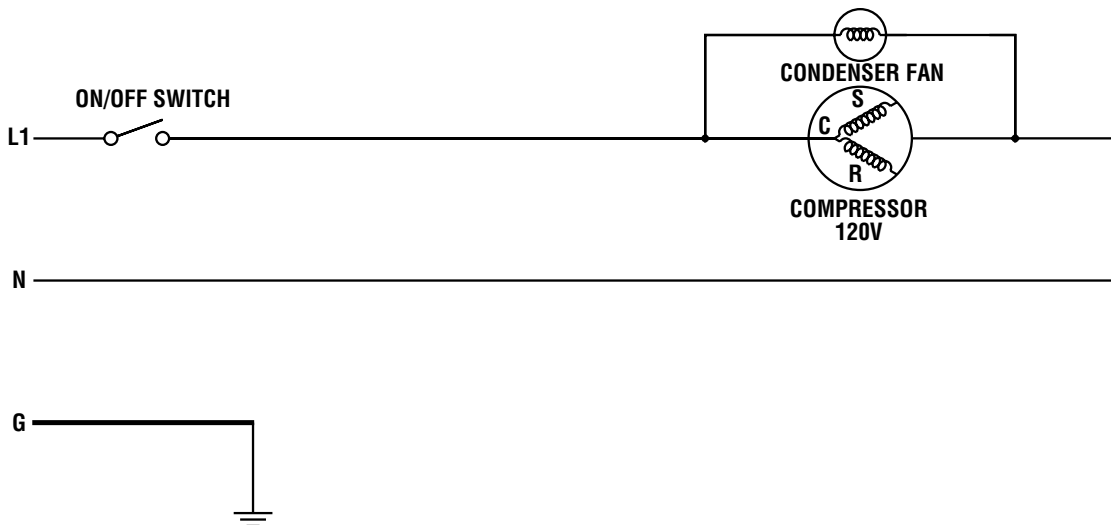

Wiring Diagram SE-H, SES-H

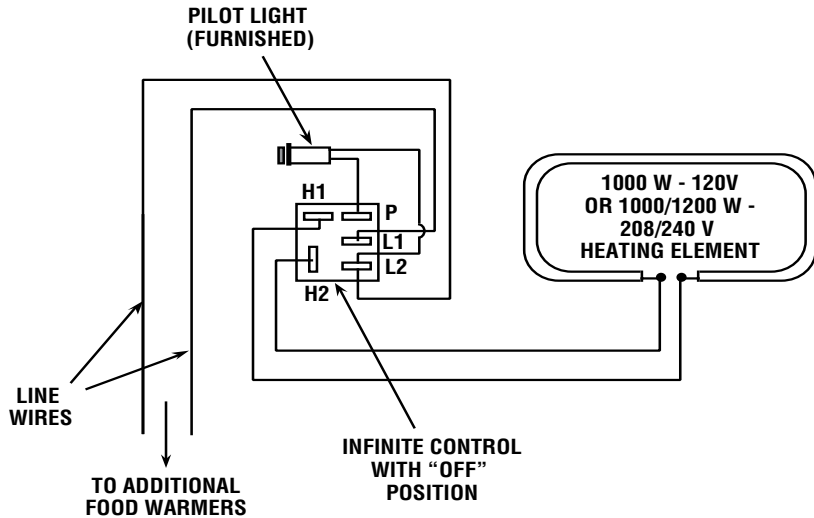

AMPERES IN LINE WIRES

# OF WARMERS	120V, 1 PHASE	208V, 1 PHASE	230V, 1 PHASE	208-230V, 3 PHASE		
				L1	L2	L3
1	8.3	4.8	5.3			
2	16.7	9.6	10.6			
3	25	14.4	15.9	14.4/15.9	14.4/15.9	14.4/15.9
4	33.3	19.2	21.3	19.2/21.3	19.2/21.3	14.4/15.9
5		24	26.6	24/26.1	19.2/21.3	19.2/21.3
6		28.8	31.3	28.8/31.3	28.8/31.3	28.8/31.3

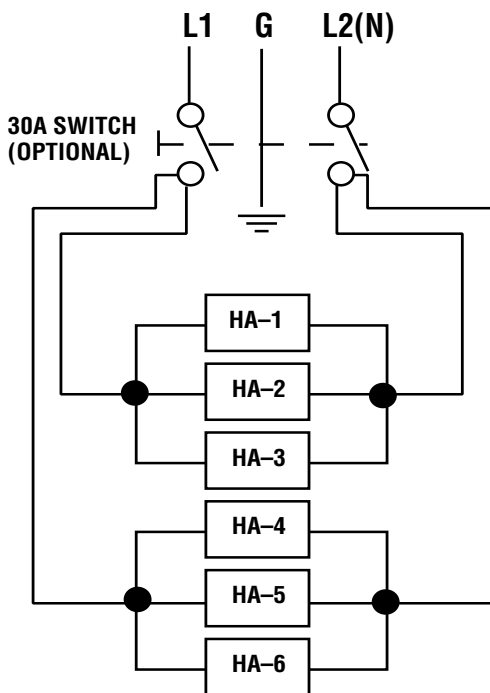

Standard Single Phase

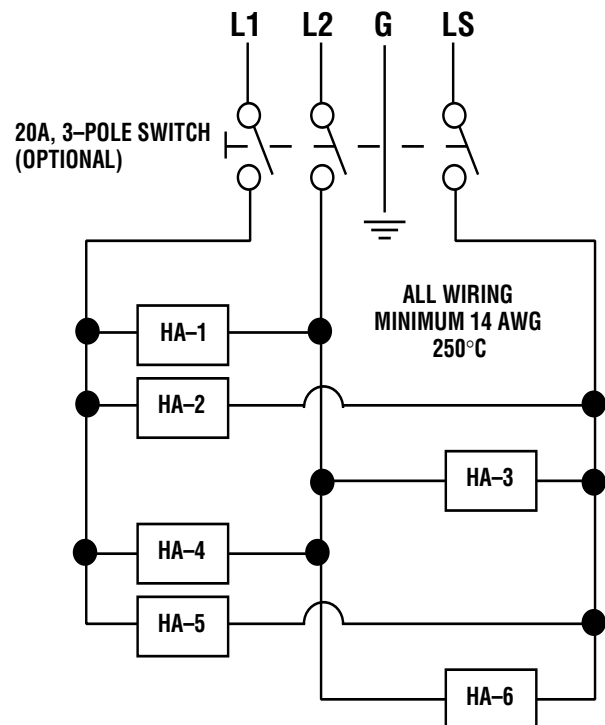

Optional Three Phase

Wiring Diagram SE-HC2, SES-HC2

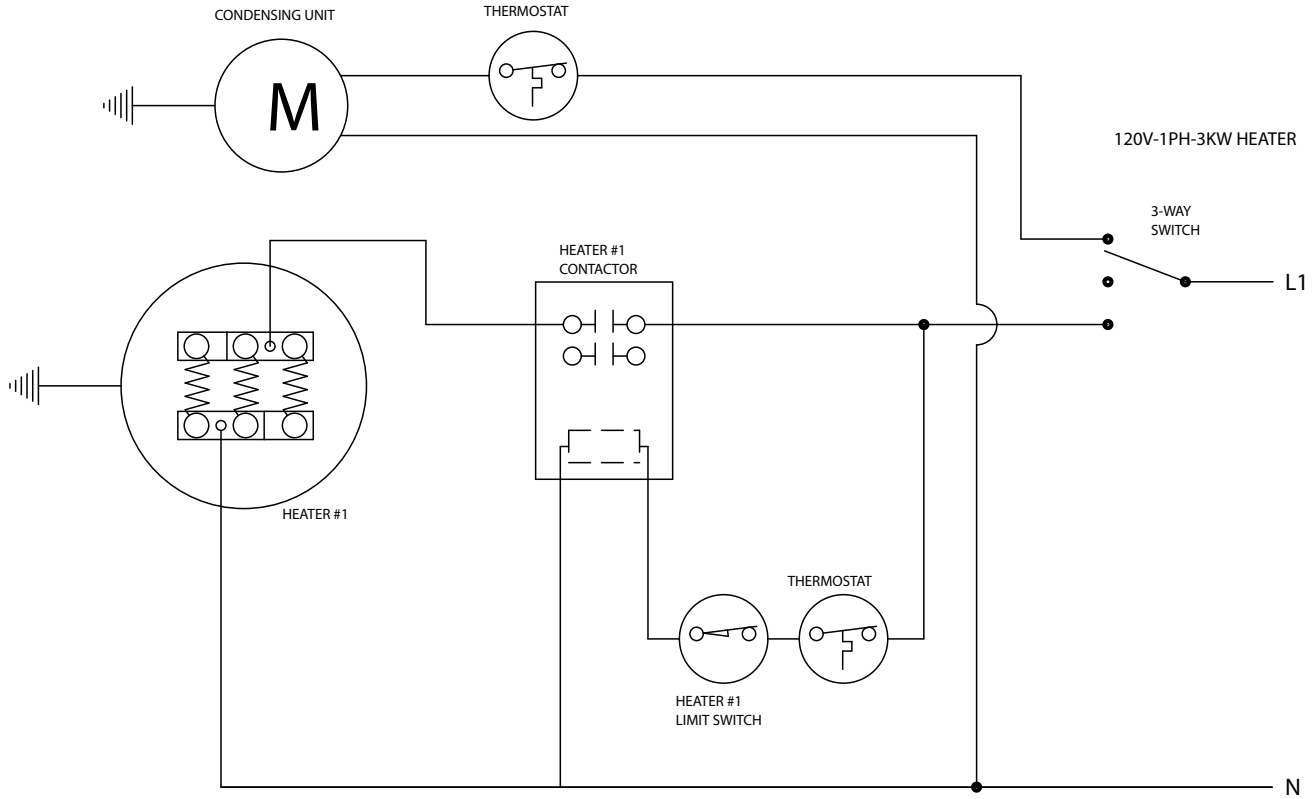

Wiring Diagram SE-HC3, SES-HC3, SE-HC4, SES-HC4

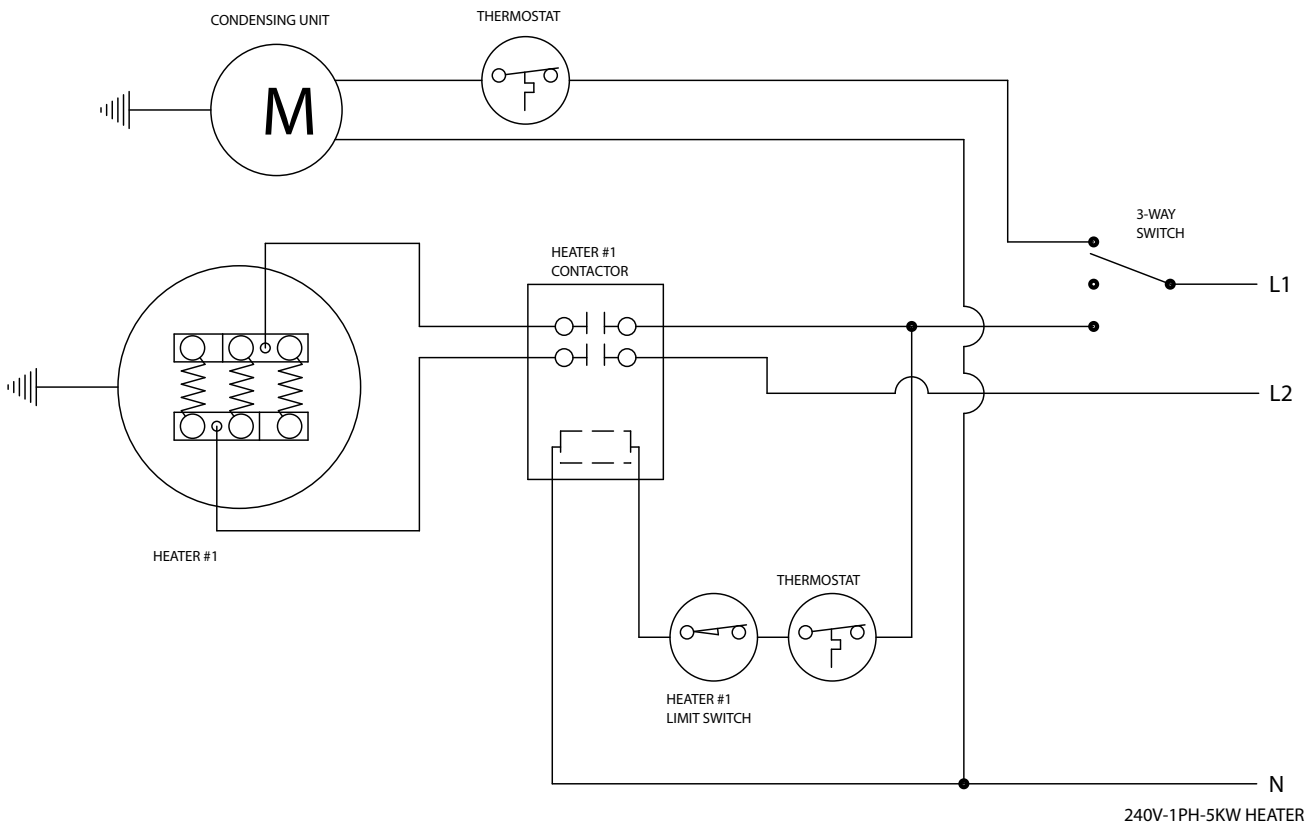

Wiring Diagram SE-HC5, SES-HC5, SE-HC6, SES-HC6

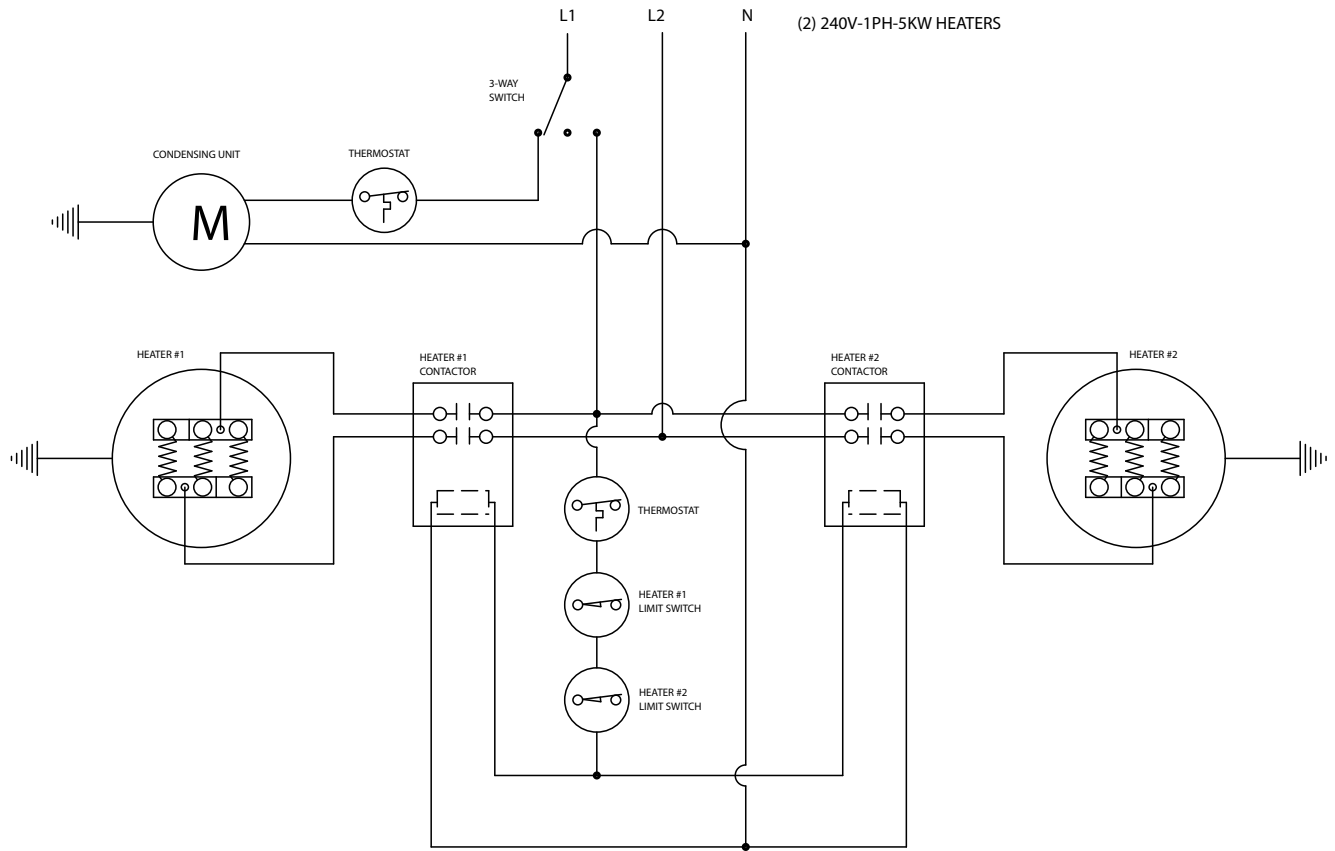

Condensing Unit Assembly, Cold Pan Units

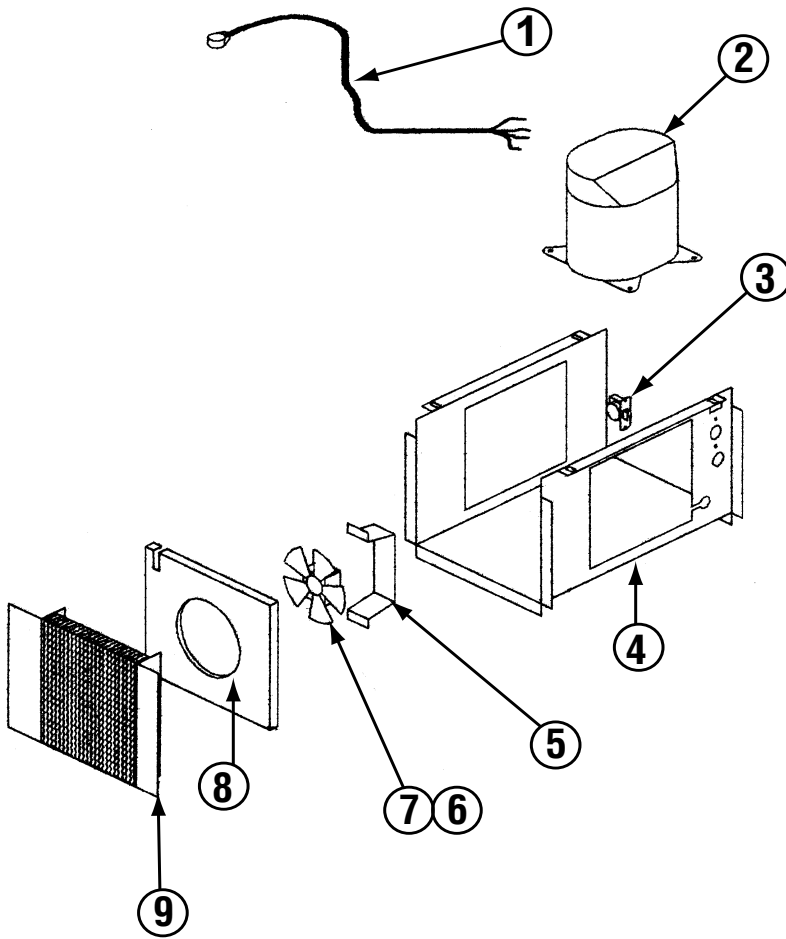

**1/5 Horse Power, R-134a, Low
SE-C2, SES-C2, SE-C3, SES-CE3 Models**

Key	Delfield Part #	Description
1	2183300	Harness, wire, power cord, 8100
2	3526694	Compressor, 1/5 h.p., 115v/60hz
3	3516047	Thermostat
4	024-ADB-0040	Compressor stand
5	031-264-0000	Bracket, fan motor, blower coil
6	3516172	Blade, fan, 5.56, CCW, Lexan, clear
7	2162691	Motor, fan, 115v, 50/60, UPPCO/bay
8	026-ANM-0030	Fan baffle
9	3516067	Coil, condenser, 9 x 10, R-134a, 8100
-	3516191	Filter dryer
-		Cap tube, 0.036"ID x 72" long

**1/4 HP, R134A Condensing Unit
SE-C4, SES-C4, SE-C5, SES-CE5, SE-C6, SES-CE6 Models**

Key	Delfield Part #	Description
1	2183300	Harness, wire, cold pans
2	3526695	Compressor, 1/4 HP
3	3516047	Control, temp, single pole
4	024-ADB-0041	Compressor stand
7	2194013	Fan assembly, 8 blade
8	026-ANM-0033	Baffle, fan
9	3516067	Coil, condenser, 9x10, R134A
	3516191	Dryer, filter, 1/4"OD inlet
		Tubing, capillary, .042"ID x 120"

Condensing Unit Assembly 1/4 H.P. R404a, Low

SE-HC2, SES-HC2, SE-HC3, SES-HC3, SE-HC4, SES-HC4, SE-HC5, SES-HC5, SE-F2, SES-F2, SE-F3, SES-F3, SE-F4, SES-F4, SE-F5, & SES-F5 Models

Key	Delfield Part #	Description
-	000-BN5-0030	Condensing Unit Assembly
1	026-C58-0030	Shroud, 1/5 HP Condenser Coil
2	3516457	Blade, Fan, 7.25"
3	2162717	Motor, fan, 9W, 115V, Unit bearing
4	2160020	Guard, Fan, 7.25"
5	3526999	Comp, NF5.5CLX, 115V/60Hz, Danfoss
6	3516443	Comp, cover, small Danfoss
7	2194787	Capacitor, Start 280MFD
8	3516444	Comp, relay, ovid, NF5.5CLX
9	3516322	Filter-dryer, (2) inlet .25"
10	075-231-0030	Pan, condensate, SM
11	3516454	Coil, 1/5 and 1/4 HP

Miscellaneous Parts Not Included in Condensing Unit

- 3516225 Expansion valve
- 2194099 Switch, 15Amp, SPST (SE & SE-F Models only)

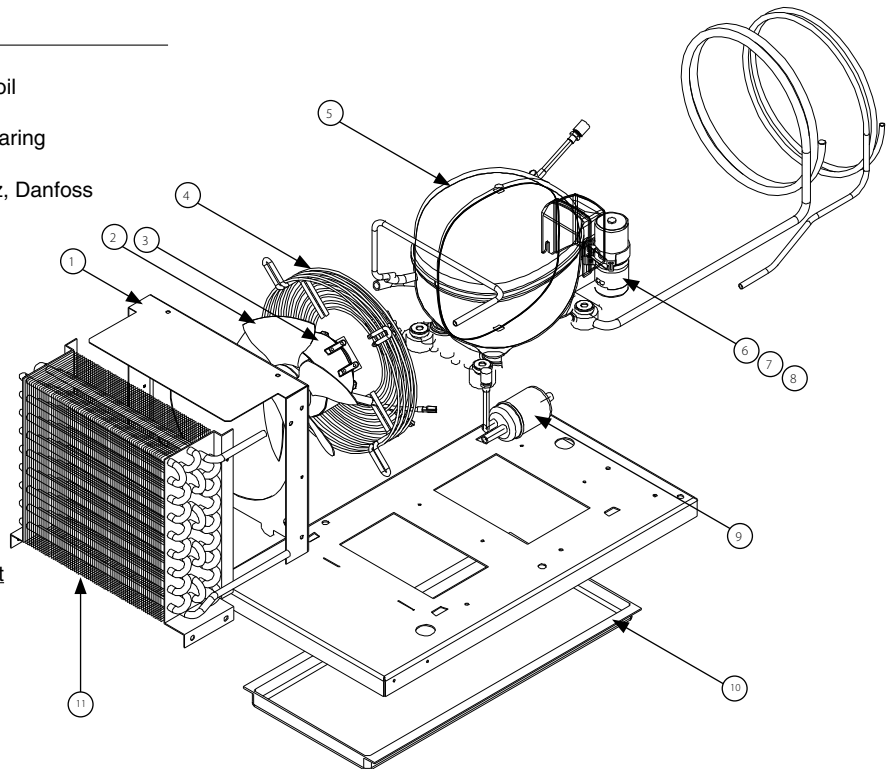

Condensing Unit Assembly 1/3 H.P. R404a, Low

SE-HC6, SES-HC6, SE-F6, & SES-F6 Models

Key	Delfield Part #	Description
-	000-BN5-003G	Condensing Unit Assembly
1	026-C58-0030	Shroud, 1/5 HP Condenser Coil
2	3516457	Blade, Fan, 7.25"
3	2162717	Motor, fan, 9W, 115V, Unit bearing
4	2160020	Guard, Fan, 7.25"
5	3527000	Comp, NF7.0. 115V/60Hz, Danfoss
6	3516324	High pressure cutout
7	3516443	Comp, cover, small Danfoss
8	2194788	Capacitor, Start 320MFD
9	3516438	Comp, relay, ovid, NF7CLX
10	3516322	Filter-dryer, (2) inlet .25"
11	3516458	Receiver tank
12	075-231-0030	Pan, condensate, SM
13	3516454	Coil, 1/5 and 1/4 HP

Miscellaneous Parts Not Included in Condensing Unit

- 3516225 Expansion valve

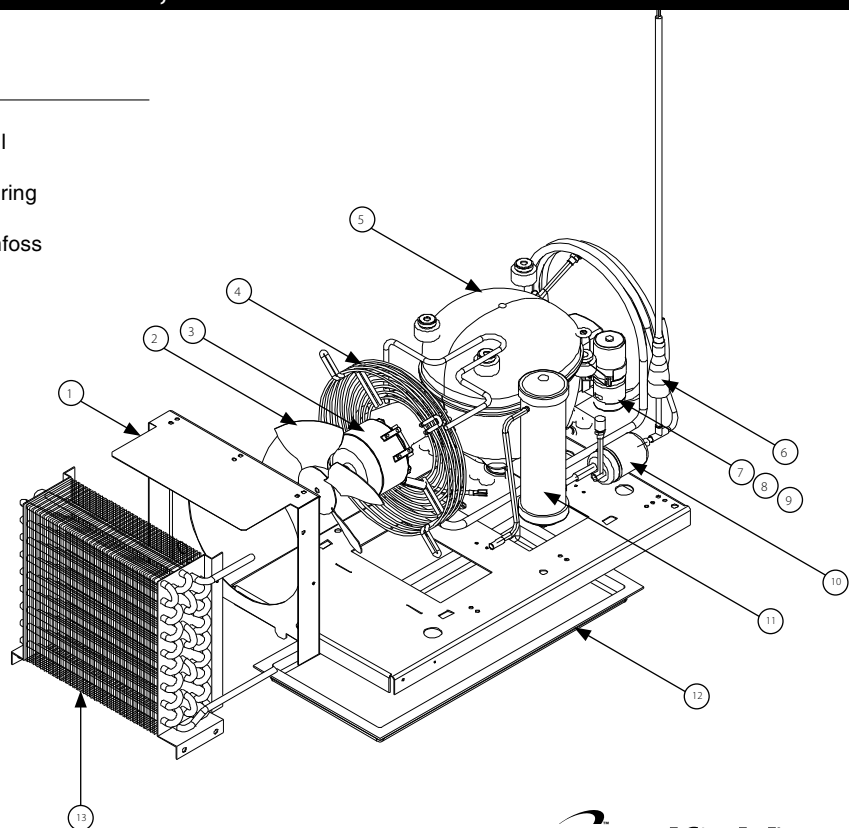

Condensing Unit Assembly 1/5 H.P. R404a, Low, SE-ICE1, SE-ICE2

Key	Delfield Part #	Description
1	026-ANM-0030	Baffle, fan, 1/5HP condensing unit
2	3516172	Blade, fan, 5.56, CCW, Lexan, clear
3	2162691	Motor, fan 115V, 50/60, Uppco/Bay
4	031-264-0000	Bracket, fan, motor, freezer
5	3516191	Filter, dryer
6	3526997	Compressor, TF4CLX, 115V/60Hz, Danfoss, SE-ICE1
6	3526996	Compressor, 1/5HP, 115/60, R404A, TFS4.5, SE-ICE2
7	3516047	Control, temp, single pole
8	2194787	Capacitor, start, 280MFD
9	3516446	Compressor, relay, overload, TF4LCX
10	3516443	Compressor, cover
11	2190154	Switch, rocker, 20A/125V, 15A/250V
12	3516067	Coil, condenser, 9x10
-	-	Capillary tubing, .031 x 120"
-	2183349	Harness, wire, power cord
-	3234188	Lid
-	3516287	Switch, high pressure, 404A

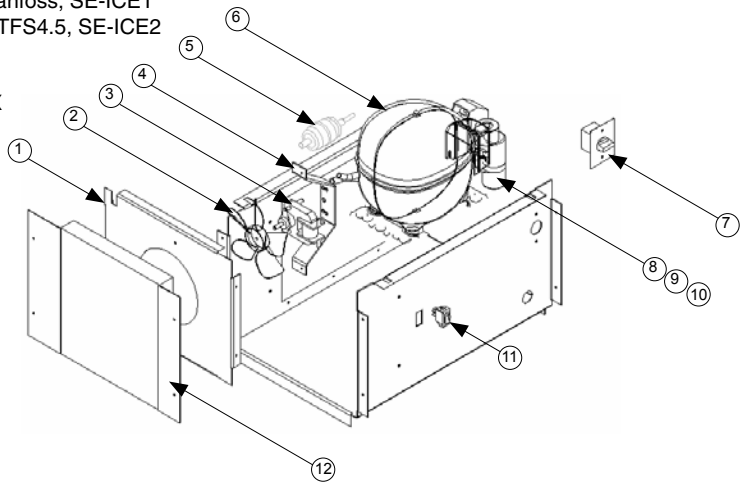

Hot Food Well Assembly With Infinite Control

Key	Delfield Part #	Description
1	3434703	Insulation, fiberglass, 9" x 48"
2	2194335	Thermostat, non-adjustable, 480°F
3	026-103-0002	Bottom cover
4	3434663	Insulation, blanket, 12" wide
5	026-061-0001	Plate, deflector, DFW, with or without drain
6	2194007	Element, heating, 208/230v, 1000/1222w
6	2194006	Element, heating, 120v
7	000-BQ9-Z0000	Well, hot food, with drain
7	000-BQ9-Z0001	Well, hot food, without drain
-	3234557	Knob, infinite control
-	2194110	Control, infinite, 240v, 14a
-	2194107	Control, infinite, 120v

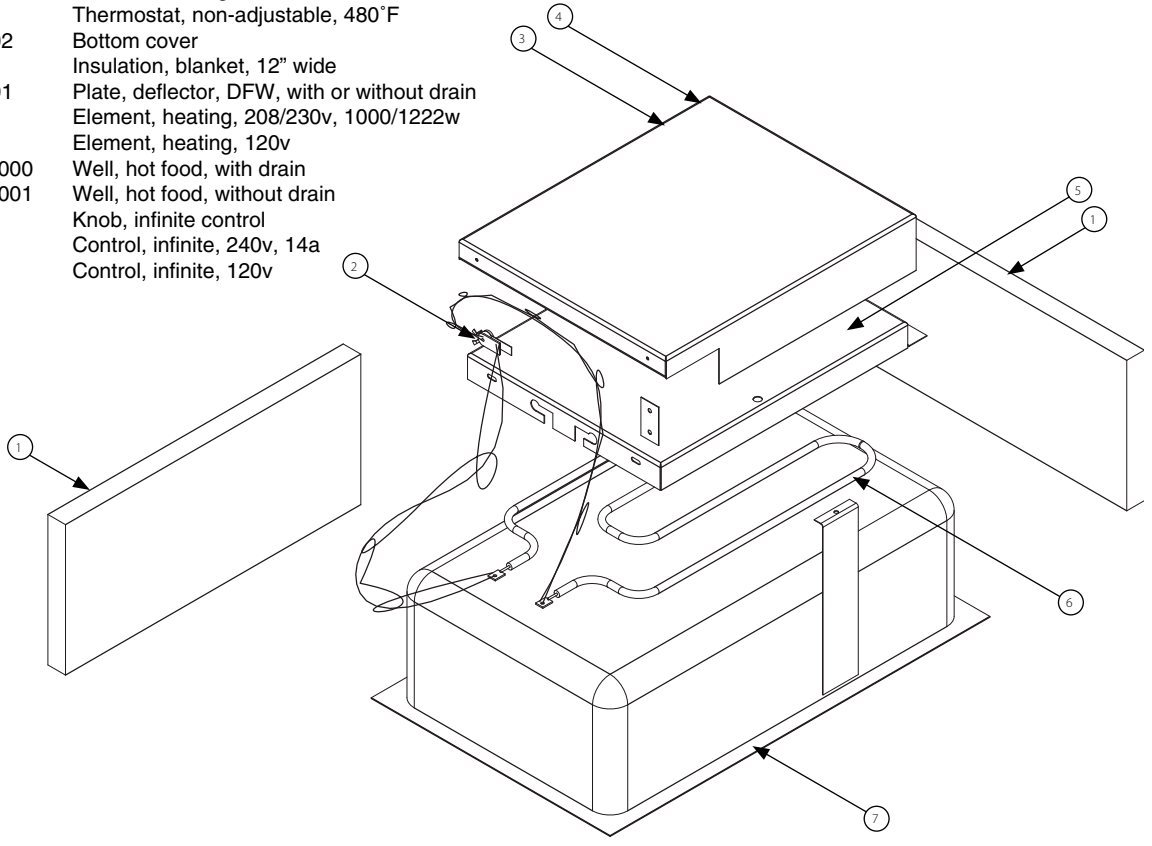

Food Well Assembly With Thermostat Control SE-HC, SES-HC

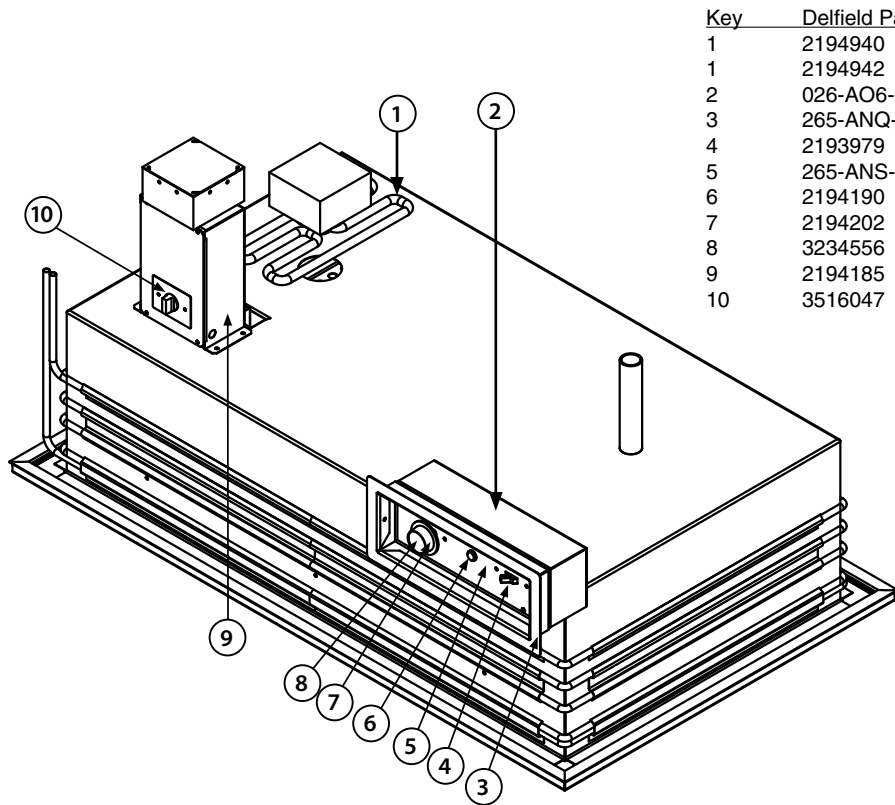

Key	Delfield Part #	Description
1	2194940	Immersion heater 120V 1Ph 3KW, 2 pan
1	2194942	Immersion heater 240V 1Ph 5KW. 3-6 pan
2	026-AO6-0042	Box, control, galv
3	265-ANQ-003E	Front, collar, mounting
4	2193979	Switch, 3 position, 30Amp
5	265-ANS-0001	Cover, control box
6	2194190	Light, pilot, 125V, red
7	2194202	Thermostat, electric (heated)
8	3234556	Knob, thermostat control (heated)
9	2194185	Contact, relay 30 Amp 120V
10	3516047	Temperature control (cold)

Miscellaneous Replacement Parts

Key	Delfield Part #	Description
1	243-ABO-0001	Adapter bar, hot and cold wells
2	3234242	1" plastic drain, cold pans only
3	3234161	5" diameter casters
4	356-ANE-0030	Air flow divider/louwer, SE-C models
4	4356-ANE-0031	Air flow divider/louwer, SES-C models
4	356-ANE-0032	Air flow divider/louwer, SE-HC models
4	356-ANE-0033	Air flow divider/louwer, SES-HC models
4	356-ANE-0034	Air flow divider/louwer, SE-ICE models
5	074-AK8-003C	Panel, ABS, Black, 20.50" x 23.50"
5	074-AK8-003B	Panel, ABS, Black, 20.50" x 29.50"
5	074-AK8-0036	Panel, ABS, Black, 21.50" x 23.50"
5	074-AK8-0030	Panel, ABS, Black, 21.50" x 29.50"
5	074-AK8-0038	Panel, ABS, Black, 27" x 23.50"
5	074-AK8-0032	Panel, ABS, Black, 27" x 29.50"
5	074-AK8-0037	Panel, ABS, Black, 31.50" x 23.50"
5	074-AK8-0031	Panel, ABS, Black, 31.50" x 29.50"
5	074-AK8-0039	Panel, ABS, Black, 34" x 23.50"
5	074-AK8-0033	Panel, ABS, Black, 34" x 29.50"
5	074-AK8-003A	Panel, ABS, Black, 41" x 23.50"
5	074-AK8-0034	Panel, ABS, Black, 41" x 29.50"
5	039-AK8-003C	Panel, ABS, Blue, 20.50" x 23.50"
5	039-AK8-003B	Panel, ABS, Blue, 20.50" x 29.50"
5	039-AK8-0036	Panel, ABS, Blue, 21.50" x 23.50"
5	039-AK8-0030	Panel, ABS, Blue, 21.50" x 29.50"
5	039-AK8-0038	Panel, ABS, Blue, 27" x 23.50"
5	039-AK8-0032	Panel, ABS, Blue, 27" x 29.50"
5	039-AK8-0037	Panel, ABS, Blue, 31.50" x 23.50"
5	039-AK8-0031	Panel, ABS, Blue, 31.50" x 29.50"
5	039-AK8-0039	Panel, ABS, Blue, 34" x 23.50"
5	039-AK8-0033	Panel, ABS, Blue, 34" x 29.50"
5	039-AK8-003	Panel, ABS, Blue, 41" x 23.50"
5	039-AK8-0034	Panel, ABS, Blue, 41" x 29.50"

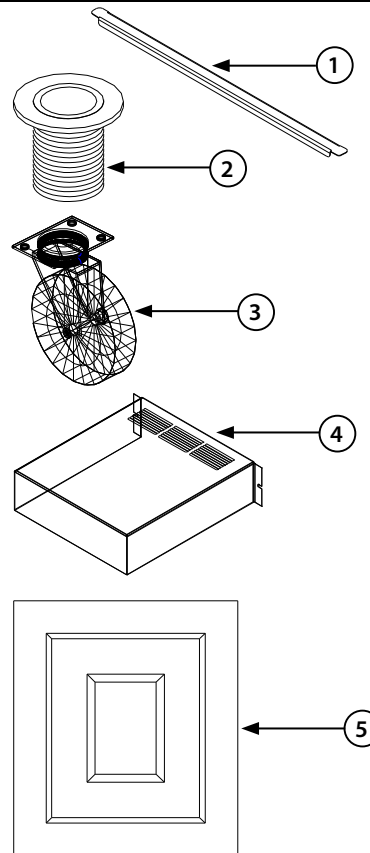

Standard Labor Guidelines To Repair Or Replace Parts On Delfield Equipment

Advice and recommendations given by Delfield Service Technicians do not constitute or guarantee any special coverage.

- A maximum of 1-hour is allowed to **diagnose a defective component**.
- A maximum of 1-hour is allowed for **retrieval of parts** not in stock.
- A maximum **travel distance** of 100 miles round trip and 2-hours will be reimbursed.
- Overtime, installation/start-up, normal control adjustments, general maintenance, glass breakage, freight damage, and/or correcting and end-user installation error will not be reimbursed under warranty unless pre-approved with a **Service Work Authorization** from Delfield. You must submit the number with the service claim.

Labor Of 1-Hour Is Allowed To Replace:

- Compressor Start Components and Overload Protector
- Condenser Fan Motor and Blade
- Hi-limit/Thermal Protector Switch
- Solenoid Coil
- Condensate Element
- Contactor/Relay
- Infinite Switch
- Thermostat

Labor Of 2 Hours To Replace:

- Heating Element
- Solenoid Valve
- Locate/Repair Leak

Labor Of 3 Hours To Replace:

- Capillary Tubing
- Expansion Valve
- Condenser

Labor Of 4 Hours To Replace:

- Compressor

This includes recovery of refrigerant and leak check.

\$55.00 maximum reimbursement for refrigerant recovery (includes recovery machine, pump, torch, oil, flux, minor fittings, solder, brazing rod, nitrogen, or similar fees.)

Refrigerants:

- R134A A maximum of \$5.00/lb. or 31¢/oz. will be reimbursed.
- R404A A maximum of \$15.00/lb. or \$1.00/oz. will be reimbursed.



Standard One Year Warranty (One year parts, 90 days labor.)

The Delfield Company ("Delfield") warrants to the Original Purchaser of the Delfield product (herein called the "Unit") that such Unit, and all parts thereof, will be free from defects in material and workmanship under normal use and service for a period of one (1) year from the date of shipment of the Unit to the Original Purchaser **or, if the Original Purchaser returns the warranty card completely filled out including the date of installation within thirty (30) days of receipt of the Unit, one (1) year from the date of installation.** During this one year warranty period, Delfield will repair or replace any defective part or portion thereof returned to Delfield by the Original Purchaser which Delfield determines was defective due to faulty material or workmanship. The Original purchaser will pay all labor, crating, freight and related costs incurred in the removal of the Unit of defective component and shipment to Delfield, except that during a period of either ninety (90) days from the date of shipment of the Unit to the Original Purchaser or, if the Original Purchaser returns the warranty card completely filled out including the date of installation within thirty (30) days of receipt of the Unit, ninety (90) days from the date of installation Delfield will pay all related labor costs. Delfield will pay the return costs if the Unit or part thereof was defective.

The term "Original Purchaser" as used herein means that person, firm, association, or corporation for whom the Unit was originally installed.

This warranty does not apply to any Unit or part thereof that has been subjected to misuse, neglect, alteration, or accident, such as accidental damage to the exterior finish, operated contrary to the recommendations specified by Delfield; or repaired or altered by anyone other than Delfield in any way so as to, in Delfield's sole judgement, affect its quality or efficiency. This warranty does not apply to any Unit that has been moved from the location where it was originally installed. This warranty also does not cover the refrigerator drier or the light bulbs used in the Unit. **The warranty is subject to the user's normal maintenance and care responsibility as set forth in the Service and Installation Manual, such as cleaning the condenser coil, and is in lieu of all other obligations of Delfield. Delfield neither assumes, nor authorizes any other person to assume for Delfield, any other liability in connection with Delfield's products.**

Removal or defacement of the original Serial Number or Model Number from any Unit shall be deemed to release Delfield from all obligations hereunder or any other obligations, express or implied.

Parts furnished by suppliers to Delfield are guaranteed by Delfield only to the extent of the original manufacturer's express warranty to Delfield. Failure of the Original Purchaser to receive such manufacturer's express warranty to Delfield. Failure of the Original Purchaser to receive such manufacturer's warranty shall in no way create any warranty, expressed or implied, or any other obligation or liability on Delfield's part in respect thereof.

IF THE CUSTOMER IS USING A PART THAT RESULTS IN A VOIDED WARRANTY AND A DELFIELD AUTHORIZED REPRESENTATIVE TRAVELS TO THE INSTALLATION ADDRESS TO PERFORM WARRANTY SERVICE, THE SERVICE REPRESENTATIVE WILL ADVISE CUSTOMER THE WARRANTY IS VOID. SUCH SERVICE CALLS WILL BE BILLED TO CUSTOMER AT THE AUTHORIZED SERVICE CENTER'S THEN APPLICABLE TIME AND MATERIALS RATES. CONSIDER: CUSTOMER MAY INITIATE A SERVICE AGREEMENT WITHOUT PARTS COVERAGE.

If shipment of a replacement part is requested prior to the arrival in the Delfield factory of the part claimed to be defective, the Original Purchaser must accept delivery of the replacement part of a C.O.D.

basis, with credit being issued after the part has been received and inspected at Delfield's plant and determined by Delfield to be within this warranty.

Under no condition does this warranty give the Original Purchaser the right to replace the defective Unit with a complete Unit of the same manufacturer or of another make. Unless authorized by Delfield in writing, this warranty does not permit the replacement of any part, including the motor-compressor, to be made with the part of another make or manufacturer.

No claims can be made under this warranty for spoilage of any products for any reason, including system failure.

The installation contractor shall be responsible for building access, entrance and field conditions to insure sufficient clearance to allow any hood(s), vent(s), or Unit(s) if necessary, to be brought into the building. Delfield will not be responsible for structural changes or damages incurred during installation of the Unit or any exhaust system.

Delfield shall not be liable in any manner for any default or delay in performance hereunder caused by or resulting from any contingency beyond Delfield's control, including, but not limited to, war, governmental restrictions or restraints, strike, lockouts, injunctions, fire, flood, acts of nature, short or reduced supply of raw materials, or discontinuance of the parts by the original part manufacturer.

Except as provided in any Additional Four Year Protection Plan, if applicable, and the Service Labor Contract, if applicable, the foregoing is exclusive and in lieu of all other warranties, whether written or oral, express or implied. This warranty supersedes and excludes any prior oral or written representations or warranties. Delfield expressly disclaims any implied warranties of merchantability, fitness for a particular purpose of compliance with any law, treaty, rule or regulation relating to the discharge of substances into the environment. The sole and exclusive remedies of any person relating to the Unit, and the full liability of Delfield for any breach of this warranty, will be as provided in this warranty.

Other than this Delfield Standard One Year Limited Warranty, any applicable Delfield Additional Four Year Protection Plan or applicable Delfield Service Labor Contract, the Original Purchaser agrees and acknowledges that no other warranties are offered or provided in connection with or for the unit or any other part thereof.

In no event will Delfield be liable for special, incidental or consequential damages, or for damages in the nature of penalties.

IF DURING THE WARRANTY PERIOD, CUSTOMER USES A PART FOR THIS DELFIELD EQUIPMENT OTHER THAN AN UNMODIFIED NEW OR RECYCLED PART PURCHASED DIRECTLY FROM DELFIELD OR ANY OF ITS AUTHORIZED SERVICE CENTERS AND/OR THE PART BEING USED IS MODIFIED FROM ITS ORIGINAL CONFIGURATION, THIS WARRANTY WILL BE VOID. FURTHER, DELFIELD AND ITS AFFILIATES WILL NOT BE LIABLE FOR ANY CLAIMS DAMAGES OR EXPENSES INCURRED BY THE CUSTOMER WHICH ARISE DIRECTLY OR INDIRECTLY, IN WHOLE OR IN PART, DUE TO THE INSTALLATION OF ANY MODIFIED PART AND/OR PART RECEIVED FROM AN UNAUTHORIZED SERVICE CENTER. If the warranty becomes void, Customer may purchase from Delfield, if available, a Service Agreement or service at the then current time and materials rate.

For more information on Delfield warranty's log on and check out the service section of our web site at www.delfield.com.

Notes





Mt. Pleasant, MI



Covington, TN

Thank you for choosing Delfield!

Help is a phone call away. Help our team of professional, courteous customer service reps by having your model number and serial number available at the time of your call (800) 733-8829.

Model: _____ S/N: _____

Installation Date: _____



**For a list of Delfield's authorized parts depots,
visit our website at www.delfield.com.**



Free Manuals Download Website

<http://myh66.com>

<http://usermanuals.us>

<http://www.somanuals.com>

<http://www.4manuals.cc>

<http://www.manual-lib.com>

<http://www.404manual.com>

<http://www.luxmanual.com>

<http://aubethermostatmanual.com>

Golf course search by state

<http://golfingnear.com>

Email search by domain

<http://emailbydomain.com>

Auto manuals search

<http://auto.somanuals.com>

TV manuals search

<http://tv.somanuals.com>